



State of West Virginia
 Department of Administration
 Purchasing Division
 2019 Washington Street East
 Post Office Box 50130
 Charleston, WV 25305-0130

**Request for
 Quotation**

RFQ NUMBER
DNRB11212

PAGE
1

ADDRESS CORRESPONDENCE TO ATTENTION OF:
**FRANK WHITTAKER
 304-558-2316**

VENDOR

**RFQ COPY
 TYPE NAME/ADDRESS HERE**
 OM Office Supply Inc.
 5007 Carlisle Pike, Suite 101
 Mechanicsburg, PA 17050
 Tel:717-763-4216 Fax:717-763-4354
 e-mail: mani@omos.com

SHIP TO

**DIVISION OF NATURAL RESOURCES
 VARIOUS LOCALES AS INDICATED
 BY ORDER**

DATE PRINTED 06/16/2011	TERMS OF SALE NET 30	SHIP VIA Truck	F.O.B. Destination	FREIGHT TERMS Free
BID OPENING DATE: 07/20/2011		BID OPENING TIME 01:30PM		

LINE	QUANTITY	UOP	CAT NO	ITEM NUMBER	UNIT PRICE	AMOUNT
0001	1	LS		840-60		
FLAT SCREEN TELEVISIONS					TOTAL :	124369-00
<p>THE WEST VIRGINIA PURCHASING DIVISION, FOR THE AGENCY, THE WEST VIRGINIA DIVISION OF NATURAL RESOURCES IS SOLICITING BIDS FOR FLAT SCREEN TELEVISIONS AND MOUNTING HARDWARE FOR SEVERAL STATE PARKS, PER THE ATTACHED SPECIFICATIONS.</p> <p>ALL TECHNICAL QUESTIONS MUST BE SUBMITTED IN WRITING TO FRANK WHITTAKER IN THE WV PURCHASING DIVISION VIA EMAIL AT FRANK.M.WHITTAKER@WV.GOV OR VIA FAX AT 304-558-4115. DEADLINE FOR TECHNICAL QUESTIONS IS 06/28/2011 AT 4:00 PM. ALL TECHNICAL QUESTIONS WILL BE ADDRESSED BY ADDENDUM AFTER THE DEADLINE.</p> <p>EXHIBIT 4</p> <p>LOCAL GOVERNMENT BODIES: UNLESS THE VENDOR INDICATES IN THE BID HIS REFUSAL TO EXTEND THE PRICES, TERMS, AND CONDITIONS OF THE BID TO COUNTY, SCHOOL, MUNICIPAL AND OTHER LOCAL GOVERNMENT BODIES, THE BID SHALL EXTEND TO POLITICAL SUBDIVISIONS OF THE STATE OF WEST VIRGINIA. IF THE VENDOR DOES NOT WISH TO EXTEND THE PRICES, TERMS, AND CONDITIONS OF THE BID TO ALL POLITICAL SUBDIVISIONS OF THE STATE, THE VENDOR MUST CLEARLY INDICATE SUCH REFUSAL IN HIS BID. SUCH REFUSA</p>						



SEE REVERSE SIDE FOR TERMS AND CONDITIONS

SIGNATURE  TELEPHONE **717-763-4216** DATE **07/18/2011**

TITLE **V.P** FEIN **25-1794667** ADDRESS CHANGES TO BE NOTED ABOVE

WHEN RESPONDING TO RFQ, INSERT NAME AND ADDRESS IN SPACE ABOVE LABELED 'VENDOR'

GENERAL TERMS & CONDITIONS
REQUEST FOR QUOTATION (RFQ) AND REQUEST FOR PROPOSAL (RFP)

1. Awards will be made in the best interest of the State of West Virginia.
2. The State may accept or reject in part, or in whole, any bid.
3. Prior to any award, the apparent successful vendor must be properly registered with the Purchasing Division and have paid the required \$125 fee.
4. All services performed or goods delivered under State Purchase Order/Contracts are to be continued for the term of the Purchase Order/Contracts, contingent upon funds being appropriated by the Legislature or otherwise being made available. In the event funds are not appropriated or otherwise available for these services or goods this Purchase Order/Contract becomes void and of no effect after June 30.
5. Payment may only be made after the delivery and acceptance of goods or services.
6. Interest may be paid for late payment in accordance with the *West Virginia Code*.
7. Vendor preference will be granted upon written request in accordance with the *West Virginia Code*.
8. The State of West Virginia is exempt from federal and state taxes and will not pay or reimburse such taxes.
9. The Director of Purchasing may cancel any Purchase Order/Contract upon 30 days written notice to the seller.
10. The laws of the State of West Virginia and the *Legislative Rules* of the Purchasing Division shall govern the purchasing process.
11. Any reference to automatic renewal is hereby deleted. The Contract may be renewed only upon mutual written agreement of the parties.
12. **BANKRUPTCY:** In the event the vendor/contractor files for bankruptcy protection, the State may deem this contract null and void, and terminate such contract without further order.
13. **HIPAA BUSINESS ASSOCIATE ADDENDUM:** The West Virginia State Government HIPAA Business Associate Addendum (BAA), approved by the Attorney General, is available online at www.state.wv.us/admin/purchase/vrc/hipaa.htm and is hereby made part of the agreement. Provided that the Agency meets the definition of a Cover Entity (45 CFR §160.103) and will be disclosing Protected Health Information (45 CFR §160.103) to the vendor.
14. **CONFIDENTIALITY:** The vendor agrees that he or she will not disclose to anyone, directly or indirectly, any such personally identifiable information or other confidential information gained from the agency, unless the individual who is the subject of the information consents to the disclosure in writing or the disclosure is made pursuant to the agency's policies, procedures, and rules. Vendor further agrees to comply with the Confidentiality Policies and Information Security Accountability Requirements, set forth in <http://www.state.wv.us/admin/purchase/privacy/noticeConfidentiality.pdf>.
15. **LICENSING:** Vendors must be licensed and in good standing in accordance with any and all state and local laws and requirements by any state or local agency of West Virginia, including, but not limited to, the West Virginia Secretary of State's Office, the West Virginia Tax Department, and the West Virginia Insurance Commission. The vendor must provide all necessary releases to obtain information to enable the director or spending unit to verify that the vendor is licensed and in good standing with the above entities.
16. **ANTITRUST:** In submitting a bid to any agency for the State of West Virginia, the bidder offers and agrees that if the bid is accepted the bidder will convey, sell, assign or transfer to the State of West Virginia all rights, title and interest in and to all causes of action it may now or hereafter acquire under the antitrust laws of the United States and the State of West Virginia for price fixing and/or unreasonable restraints of trade relating to the particular commodities or services purchased or acquired by the State of West Virginia. Such assignment shall be made and become effective at the time the purchasing agency tenders the initial payment to the bidder.

I certify that this bid is made without prior understanding, agreement, or connection with any corporation, firm, limited liability company, partnership, or person or entity submitting a bid for the same material, supplies, equipment or services and is in all respects fair and without collusion or fraud. I further certify that I am authorized to sign the certification on behalf of the bidder or this bid.

INSTRUCTIONS TO BIDDERS

1. Use the quotation forms provided by the Purchasing Division. Complete all sections of the quotation form.
2. Items offered must be in compliance with the specifications. Any deviation from the specifications must be clearly indicated by the bidder. Alternates offered by the bidder as **EQUAL** to the specifications must be clearly defined. A bidder offering an alternate should attach complete specifications and literature to the bid. The Purchasing Division may waive minor deviations to specifications.
3. Unit prices shall prevail in case of discrepancy. All quotations are considered F.O.B. destination unless alternate shipping terms are clearly identified in the quotation.
4. All quotations must be delivered by the bidder to the office listed below prior to the date and time of the bid opening. Failure of the bidder to deliver the quotations on time will result in bid disqualifications: Department of Administration, Purchasing Division, 2019 Washington Street East, P.O. Box 50130, Charleston, WV 25305-0130
5. Communication during the solicitation, bid, evaluation or award periods, except through the Purchasing Division, is strictly prohibited (W.Va. C.S.R. §148-1-6.6).



State of West Virginia
 Department of Administration
 Purchasing Division
 2019 Washington Street East
 Post Office Box 50130
 Charleston, WV 25305-0130

Request for Quotation

RFQ NUMBER
DNRB11212

PAGE
2

ADDRESS CORRESPONDENCE TO ATTENTION OF
FRANK WHITTAKER
304-558-2316

VENDOR

RFQ COPY
TYPE NAME/ADDRESS HERE
 OM Office Supply Inc.
 5007 Carlisle Pike, Suite 101
 Mechanicsburg, PA 17050
 Tel: 717-763-4216 Fax: 717-763-4354
 e-mail: mani@omos.com

SHIP TO

DIVISION OF NATURAL RESOURCES
VARIOUS LOCALES AS INDICATED
BY ORDER

DATE PRINTED 06/16/2011	TERMS OF SALE NET 30	SHIP VIA Truck	F.O.B. Destination	FREIGHT TERMS Free
BID OPENING DATE: 07/20/2011		BID OPENING TIME 01:30PM		

LINE	QUANTITY	UOP	CAT. NO.	ITEM NUMBER	UNIT PRICE	AMOUNT
<p>SHALL NOT PREJUDICE THE AWARD OF THIS CONTRACT IN ANY MANNER.</p> <p>REV. 3/88 EXHIBIT 3</p> <p>LIFE OF CONTRACT: THIS CONTRACT BECOMES EFFECTIVE ON AND EXTENDS FOR A PERIOD OF ONE (1) YEAR OR UNTIL SUCH "REASONABLE TIME" THEREAFTER AS IS NECESSARY TO OBTAIN A NEW CONTRACT OR RENEW THE ORIGINAL CONTRACT. THE "REASONABLE TIME" PERIOD SHALL NOT EXCEED TWELVE (12) MONTHS. DURING THIS "REASONABLE TIME" THE VENDOR MAY TERMINATE THIS CONTRACT FOR ANY REASON UPON GIVING THE DIRECTOR OF PURCHASING 30 DAYS WRITTEN NOTICE.</p> <p>UNLESS SPECIFIC PROVISIONS ARE STIPULATED ELSEWHERE IN THIS CONTRACT DOCUMENT, THE TERMS, CONDITIONS AND PRICING SET HEREIN ARE FIRM FOR THE LIFE OF THE CONTRACT.</p> <p>RENEWAL: THIS CONTRACT MAY BE RENEWED UPON THE MUTUAL WRITTEN CONSENT OF THE SPENDING UNIT AND VENDOR, SUBMITTED TO THE DIRECTOR OF PURCHASING THIRTY (30) DAYS PRIOR TO THE EXPIRATION DATE. SUCH RENEWAL SHALL BE IN ACCORDANCE WITH THE TERMS AND CONDITIONS OF THE ORIGINAL CONTRACT AND SHALL BE LIMITED TO TWO (2) ONE (1) YEAR PERIODS.</p> <p>CANCELLATION: THE DIRECTOR OF PURCHASING RESERVES THE RIGHT TO CANCEL THIS CONTRACT IMMEDIATELY UPON WRITTEN NOTICE TO THE VENDOR IF THE COMMODITIES AND/OR SERVICES SUPPLIED ARE OF AN INFERIOR QUALITY OR DO NOT CONFORM TO THE SPECIFICATIONS OF THE BID AND CONTRACT HEREIN.</p> <p>OPEN MARKET CLAUSE: THE DIRECTOR OF PURCHASING MAY</p>						

SEE REVERSE SIDE FOR TERMS AND CONDITIONS

SIGNATURE 	TELEPHONE 717-763-4216	DATE 07/8/2011
TITLE V.P.	FEIN 25-1794667	ADDRESS CHANGES TO BE NOTED ABOVE

WHEN RESPONDING TO RFQ, INSERT NAME AND ADDRESS IN SPACE ABOVE LABELED 'VENDOR'



State of West Virginia
 Department of Administration
 Purchasing Division
 2019 Washington Street East
 Post Office Box 50130
 Charleston, WV 25305-0130

Request for Quotation

RFQ NUMBER
DNRB11212

PAGE
3

ADDRESS CORRESPONDENCE TO ATTENTION OF
FRANK WHITTAKER
304-558-2316

RFQ COPY

TYPE NAME/ADDRESS HERE

VENDOR

OM Office Supply Inc.
 5007 Carlisle Pike, Suite 101
 Mechanicsburg, PA 17050
 Tel:717-763-4216 Fax:717-763-4354
 e-mail: mani@omos.com

SHIP TO

DIVISION OF NATURAL RESOURCES
 VARIOUS LOCALES AS INDICATED
 BY ORDER

DATE PRINTED	TERMS OF SALE	SHIP VIA	F.O.B.	FREIGHT TERMS
06/16/2011	NET 30	Truck	destination	free
BID OPENING DATE: 07/20/2011		BID OPENING TIME 01:30PM		

LINE	QUANTITY	UOP	CAT NO	ITEM NUMBER	UNIT PRICE	AMOUNT
<p>AUTHORIZE A SPENDING UNIT TO PURCHASE ON THE OPEN MARKET, WITHOUT THE FILING OF A REQUISITION OR COST ESTIMATE, ITEMS SPECIFIED ON THIS CONTRACT FOR IMMEDIATE DELIVERY IN EMERGENCIES DUE TO UNFORESEEN CAUSES (INCLUDING BUT NOT LIMITED TO DELAYS IN TRANSPORTATION OR AN UNANTICIPATED INCREASE IN THE VOLUME OF WORK.)</p> <p>QUANTITIES: QUANTITIES LISTED IN THE REQUISITION ARE APPROXIMATIONS ONLY, BASED ON ESTIMATES SUPPLIED BY THE STATE SPENDING UNIT. IT IS UNDERSTOOD AND AGREED THAT THE CONTRACT SHALL COVER THE QUANTITIES ACTUALLY ORDERED FOR DELIVERY DURING THE TERM OF THE CONTRACT, WHETHER MORE OR LESS THAN THE QUANTITIES SHOWN.</p> <p>ORDERING PROCEDURE: SPENDING UNIT(S) SHALL ISSUE A WRITTEN STATE CONTRACT ORDER (FORM NUMBER WV-39) TO THE VENDOR FOR COMMODITIES COVERED BY THIS CONTRACT. THE ORIGINAL COPY OF THE WV-39 SHALL BE MAILED TO THE VENDOR AS AUTHORIZATION FOR SHIPMENT, A SECOND COPY MAILED TO THE PURCHASING DIVISION, AND A THIRD COPY RETAINED BY THE SPENDING UNIT.</p> <p>BANKRUPTCY: IN THE EVENT THE VENDOR/CONTRACTOR FILES FOR BANKRUPTCY PROTECTION, THE STATE MAY DEEM THE CONTRACT NULL AND VOID, AND TERMINATE SUCH CONTRACT WITHOUT FURTHER ORDER.</p> <p>THE TERMS AND CONDITIONS CONTAINED IN THIS CONTRACT SHALL SUPERSEDE ANY AND ALL SUBSEQUENT TERMS AND CONDITIONS WHICH MAY APPEAR ON ANY ATTACHED PRINTED DOCUMENTS SUCH AS PRICE LISTS, ORDER FORMS, SALES AGREEMENTS OR MAINTENANCE AGREEMENTS, INCLUDING ANY ELECTRONIC MEDIUM SUCH AS CD-ROM.</p> <p>REV. 05/26/2009</p>						

SEE REVERSE SIDE FOR TERMS AND CONDITIONS

SIGNATURE:  TELEPHONE: 717-763-4216 DATE: 07/8/2011

TITLE: V.P. FEIN: 25-1794667 ADDRESS CHANGES TO BE NOTED ABOVE

WHEN RESPONDING TO RFQ, INSERT NAME AND ADDRESS IN SPACE ABOVE LABELED 'VENDOR'



State of West Virginia
 Department of Administration
 Purchasing Division
 2019 Washington Street East
 Post Office Box 50130
 Charleston, WV 25305-0130

Request for Quotation

RFG NUMBER
DNRB11212

PAGE
4

ADDRESS CORRESPONDENCE TO ATTENTION OF
**FRANK WHITTAKER
 304-558-2316**

VENDOR

RFQ COPY
 TYPE NAME/ADDRESS HERE
 OM Office Supply Inc.
 5007 Carlisle Pike, Suite 101
 Mechanicsburg, PA 17050
 Tel:717-763-4216 Fax:717-763-4354
 e-mail: mani@omos.com

SHIP TO

**DIVISION OF NATURAL RESOURCES
 VARIOUS LOCALES AS INDICATED
 BY ORDER**

DATE PRINTED	TERMS OF SALE	SHIP VIA	F.O.B.	FREIGHT TERMS
06/16/2011	NET 30	Truck	Destination	Free
BID OPENING DATE: 07/20/2011		BID OPENING TIME 01:30PM		

LINE	QUANTITY	UOP	CAT NO	ITEM NUMBER	UNIT PRICE	AMOUNT
NOTICE A SIGNED BID MUST BE SUBMITTED TO: DEPARTMENT OF ADMINISTRATION PURCHASING DIVISION BUILDING 15 2019 WASHINGTON STREET, EAST CHARLESTON, WV 25305-0130						
THE BID SHOULD CONTAIN THIS INFORMATION ON THE FACE OF THE ENVELOPE OR THE BID MAY NOT BE CONSIDERED:						
SEALED BID						
BUYER:				44		
RFQ. NO.:				DNRB11212		
BID OPENING DATE:				7/20/2011		
BID OPENING TIME:				1:30 PM		
PLEASE PROVIDE A FAX NUMBER IN CASE IT IS NECESSARY TO CONTACT YOU REGARDING YOUR BID: ----- 717-763-4354 -----						
CONTACT PERSON (PLEASE PRINT CLEARLY):						

SEE REVERSE SIDE FOR TERMS AND CONDITIONS

SIGNATURE	TELEPHONE	DATE
<i>[Signature]</i>	717-763-4216	07/18/2011
TITLE	FAX	ADDRESS CHANGES TO BE NOTED ABOVE
V.P	25-1794667	

WHEN RESPONDING TO RFQ, INSERT NAME AND ADDRESS IN SPACE ABOVE LABELED 'VENDOR'



State of West Virginia
 Department of Administration
 Purchasing Division
 2019 Washington Street East
 Post Office Box 50130
 Charleston, WV 25305-0130

Request for Quotation

RFQ NUMBER:
DNRB11212

PAGE:
5

ADDRESS CORRESPONDENCE TO ATTENTION OF:
**FRANK WHITTAKER
 304-558-2316**

VENDOR

RFQ COPY
 TYPE NAME/ADDRESS HERE
 OM Office Supply Inc.
 5007 Carlisle Pike, Suite 101
 Mechanicsburg, PA 17050
 Tel:717-763-4216 Fax:717-763-4354
 e-mail: mani@omos.com

SHIP TO

DIVISION OF NATURAL RESOURCES
 VARIOUS LOCALES AS INDICATED
 BY ORDER

DATE PRINTED 06/16/2011	TERMS OF SALE NET 30	SHIP VIA Truck	F.O.B. Destination	FREIGHT TERMS Free
BID OPENING DATE: 07/20/2011		BID OPENING TIME 01:30PM		

LINE	QUANTITY	UOP	CAT NO	ITEM NUMBER	UNIT PRICE	AMOUNT
----- MANISH AGARWAL -----						
***** THIS IS THE END OF RFQ DNRB11212 ***** TOTAL:						124369-00
OM Office Supply Inc. 5007 Carlisle Pike Mechanicsburg, PA 17050 Tel: 717-763-4216						

SEE REVERSE SIDE FOR TERMS AND CONDITIONS

SIGNATURE 	TELEPHONE 717-763-4216	DATE 07/18/2011
TITLE V.P	FEIN 85-1794667	ADDRESS CHANGES TO BE NOTED ABOVE

WHEN RESPONDING TO RFQ, INSERT NAME AND ADDRESS IN SPACE ABOVE LABELED 'VENDOR'

OPEN END AGENCY CONTRACT Televisions

The West Virginia Division of Natural Resources is requesting Bids for an open ended contract for the purchase of flat screen televisions to be utilized for upgrades and redecoration of parks in various locations. All items are to be shipped FOB Destination. Vendor shall be required to submit a Bill of Lading for all material and items shipped that clearly show actual shipping costs.

General Specifications:

All items must be new, and must be Energy Star qualified. Televisions must be flat screen, and must have the availability to be mounted securely on the wall with appropriate wall mounting systems.

Basis of Award:

This contract is split into three separate bids based upon the location of the park where these items will be initially purchased. The three locations are Blackwater Falls State Park, Davis, WV, Pipestem Resort State Park, Pipestem, WV and Tygart Lake State Park, Grafton, WV.

Vendors may bid on any or all locations.

The television package will be awarded to the lowest qualified Bidder submitting the lowest Bid for all televisions and mounting hardware at each location, as stipulated on the Bid schedule and in complete accordance with all specifications stipulated herein. Partial or conditional bids will not be considered.

Coordination:

Vendor must coordinate shipping and receiving with each park. All items must be received within thirty days of the issuance of a purchase order.

Delivery, Storage and Handling:

The successful Vendor must deliver and handle all items according to Manufacturer's recommendations, including means and methods that will prevent damage, deterioration, and loss. Goods must be delivered in the Manufacturer's original sealed containers complete with labels and instructions for handling, storage, unpacking, protecting, and installing. The Division will supply labor to inspect the goods upon delivery, to ensure compliance with the purchase order, and to ensure all items are undamaged and protected against damage. All items must be delivered according to Manufacturer's recommendations and in an order that will facilitate inspection and measurement of quantity. All items must be delivered using means and methods that will prevent damage, deterioration, theft, or other loss. All items are to be shipped FOB Destination. Vendor shall be required to submit a Bill of Lading for all material and items shipped that clearly show actual shipping costs.

Locations:
BLACKWATER FALLS STATE PARK
(Tucker County)
RR 29 Drawer 490
Davis, WV 26260-0490

PIPESTEM RESORT STATE PARK
(Summers County)
RR 20 Box 150
Pipestem, WV 25979-0150

TYGART LAKE STATE PARK
(Taylor County)
RR 1 Box 260
Grafton, WV 26354-9741

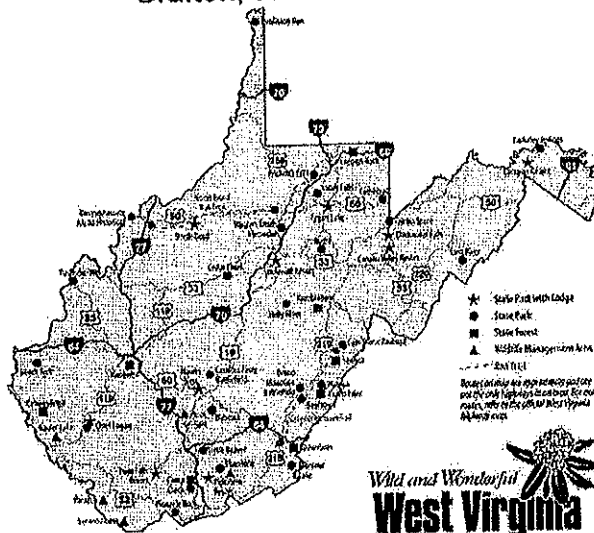

Damaged Items:

All items will be inspected by the Division at time of delivery to ensure that each item is not damaged or defective. Damaged or defective items will be rejected, and must be removed, and replaced at no additional expense to the Division.

Project Closeout:

Vendor must provide an inventory list of all items received and accepted. Vendor must provide the manufacturers recommendations for maintenance and cleaning.

Applications for Payment:

Vendor must submit Applications for Payment upon completion of delivery for all items delivered and accepted and upon completion of project closeout requirements.

Warranty:

The Vendor must warranty products to be free of defects in materials and Workmanship for a minimum period of one (1) year after date of acceptance or through manufacturer's provided warranty, whichever is greater. Vendor must repair or replace at its discretion, free of charge, any product that proves to be defective during the warranty period.

Estimated Quantities:

The quantities listed in this bid form are for bid evaluation purposes only – Actual quantities ordered may differ.

Television Specifications:

All items must meet the minimum specifications as detailed herein.

All items are to be shipped FOB Destination. Vendor shall be required to submit a Bill of Lading for all material and items shipped that clearly show actual shipping costs.

BLACKWATER FALLS STATE PARK

TELEVISION

Panasonic 42" Class 1080p LCD Model TH-42LRU30, or equal

- Must be minimum 42" Diagonal
- Minimum dimensions must be 25.1"x40.2"x4.2"
- Must be VESA mount compliant
- Must be LCD
- Must come with standard remote control
- Must have minimum contrast ratio of 20,000:1
- Must be model year 2010 or greater
- Minimum native resolution must be (1920 x 1080)
- Must have minimum 2 surround sound, full-range speakers
- Must have built in close caption decoder
- Must have sleep-off-timers and programmable timer
- Must be Energy Star® qualified

UNIVERSAL MOUNT WITH TILT

OmniMount 2N1-L, or equal

- Must be compatible with LCD Television provided under this contract
- Must fit a minimum of 37" – maximum 63" flat panel televisions
- Must support a minimum of 175 lbs
- Maximum tilt 15°
- Minimum mounting profile must be 2.7"
- Must be VESA compliant W200xH200

UNIVERSAL MOUNT WITH TILT / SWIVEL

OmniMount UCL-L, or equal

- Must be compatible with LCD Television provided under this contract
- Must fit a minimum of 37" – maximum 52" flat panel televisions
- Must support a minimum of 125 lbs.

OPEN END CONTRACT TELEVISIONS

- Must provide a minimum tilt -5° to a maximum tilt of 15°
- Minimum mounting profile must be 4.69"
- Maximum extension must be 26.8"
- Must be VESA compliant W200xH200

PIPESTEM RESORT STATE PARK

TELEVISION

LG 32" LCD TELEVISION 32LK330, or equal

- Must be minimum 31.5" Diagonal
- Must be LED
- Must have minimum contrast ratio of 70,000:1
- Minimum dimensions must be 31.5 X 22.2 X 8.1" (with stand)
- Must come with minimum 20° / 20° swivel stand
- Must come with standard remote control
- Must be model year 2010 or greater
- Minimum native resolution must be (1366x768)
- Must be Energy Star® qualified

TYGART LAKE STATE PARK

TELEVISION

LG 37" LED TELEVISION 37LV3500, or equal

- Must be minimum 37" Diagonal
- Must be LED
- Must have minimum contrast ratio of 3,000,000:1
- Minimum dimensions must be 24.9x20.9x1.6"
- Must be VESA mount compliant
- Must come with standard remote control
- Must be model year 2010 or greater
- Minimum native resolution must be (1920x1080)
- Must be Energy Star® qualified

TELEVISION

LG 55" LED TELEVISION 55LV5500, or equal

- Must be minimum 54.6" Diagonal
- Must be LED
- Must have minimum contrast ratio of 5,000,000:1
- Minimum dimensions must be 51.1"x30.6"x1.2"
- Must be VESA mount compliant
- Must come with standard remote control
- Must be model year 2010 or greater
- Minimum native resolution must be (1920x1080)
- Must be Energy Star® qualified

UNIVERSAL MOUNT WITH TILT

OmniMount 2N1-L, or equal

- Must be compatible with LED Television provided under this contract
- Must fit a minimum of 37" – maximum 63" flat panel televisions
- Must support a minimum of 175 lbs

OPEN END CONTRACT TELEVISIONS

- Maximum tilt 15°
- Minimum mounting profile must be 2.7"
- Must be VESA compliant

UNIVERSAL MOUNT WITH TILT / SWIVEL

OmniMount LEDP75, or equal

- Must be compatible with LED Television provided under this contract
- Must fit a minimum of 23" – maximum 60" flat panel televisions
- Must support a minimum of 75 lbs
- Minimum tilt -10° to maximum tilt 10°
- Minimum mounting profile: 0.6" in-wall; 2.23" on-wall
- Minimum lateral shift 11.35"
- Must be VESA compliant

BID FORM - TELEVISIONS
PIPESTEM RESORT STATE PARK

Item No.	Description	ESTIMATED QUANTITY	UNIT PRICE	EXTENDED PRICE
1	32" LCD TELEVISION	132	\$ 325-00	\$ 42900-00
TOTAL BID				\$ 42900-00

All items are to be shipped FOB Destination. Vendor shall be required to submit a Bill of Lading for all material and items shipped that clearly show actual shipping costs.

THE QUANTITIES LISTED ABOVE ARE FOR BID EVALUATION PURPOSES ONLY. ACTUAL QUANTITIES MAY DIFFER

OM Office Supply Inc.
 5007 Carlisle Pike
 Mechanicsburg, PA 17050
 Tel: 717-763-4216

BID FORM - TELEVISIONS
BLACKWATER FALLS STATE PARK

Item No.	Description	ESTIMATED QUANTITY	UNIT PRICE	EXTENDED PRICE
1	42" LCD TELEVISION	74	\$ 825-00	\$ 61050-00
2	UNIVERSAL MOUNT WITH TILT	70	\$ 51-00	\$ 3570-00
3	UNIVERSAL MOUNT WITH TILT / SWIVEL	4	\$ 195-00	\$ 780-00
TOTAL BID				\$ 65400-00

All items are to be shipped FOB Destination. Vendor shall be required to submit a Bill of Lading for all material and items shipped that clearly show actual shipping costs.

THE QUANTITIES LISTED ABOVE ARE FOR BID EVALUATION PURPOSES ONLY. ACTUAL QUANTITIES MAY DIFFER.

OM Office Supply Inc.
 5007 Carlisle Pike
 Mechanicsburg, PA 17050
 Tel: 717-763-4216

BID FORM - TELEVISIONS
TYGART LAKE STATE PARK

Item No.	Description	ESTIMATED QUANTITY	UNIT PRICE	EXTENDED PRICE
1	37" LED TELEVISION	21	\$ 558-00	\$ 11718-00
2	55" LED TELEVISION	2	\$ 1490-00	\$ 2980-00
3	UNIVERSAL MOUNT WITH TILT	21	\$ 51-00	\$ 1071-00
4	UNIVERSAL MOUNT WITH TILT / SWIVEL	2	\$ 150-00	\$ 300-00
TOTAL BID				\$ 16069-00

All items are to be shipped FOB Destination. Vendor shall be required to submit a Bill of Lading for all material and items shipped that clearly show actual shipping costs.

THE QUANTITIES LISTED ABOVE ARE FOR BID EVALUATION PURPOSES ONLY. ACTUAL QUANTITIES MAY DIFFER

OM Office Supply Inc.
 5007 Carlisle Pike
 Mechanicsburg, PA 17050
 Tel: 717-763-4216

MANUFACTURER SHEET - TELEVISIONS

PIPESTEM RESORT STATE PARK

Item No.	Description	Manufacturer
1	32" LCD TELEVISION	32LK330 / LG.

OM Office Supply Inc.
5007 Carlisle Pike
Mechanicsburg, PA 17050
Tel: 717-763-4216

MANUFACTURER SHEET - TELEVISIONS
BLACKWATER FALLS STATE PARK

Item No.	Description	Manufacturer
1	42" LCD TELEVISION	TH42LRU30 / Panasonic
2	UNIVERSAL MOUNT WITH TILT	TH3070UT / ATDEC
3	UNIVERSAL MOUNT WITH TILT / SWIVEL	TH3270UFM / ATDEC

Quoting equal
 Quoting equal
 of Specifications
 Attached.

OM Office Supply Inc.
 5007 Carlisle Pike
 Mechanicsburg, PA 17050
 Tel: 717-763-4216

MANUFACTURER SHEET - TELEVISIONS
TYGART LAKE STATE PARK

Item No.	Description	Manufacturer
1	37" LED TELEVISION	JLE37BC3001 / JVC
2	55" LED TELEVISION	55LV5500 / LG
3	UNIVERSAL MOUNT WITH TILT	TH3070UT / ATDEC.
4	UNIVERSAL MOUNT WITH TILT / SWIVEL	LEDPT5 / OMNIMOUNT

→ Quoting equal

→ Quoting equal

* Specifications Attached.

Office Supply Inc.
 5007 Carlisle Pike
 Harrisburg, PA 17050
 Tel 717-763-4216

State of West Virginia

VENDOR PREFERENCE CERTIFICATE

Certification and application* is hereby made for Preference in accordance with West Virginia Code, §5A-3-37. (Does not apply to construction contracts). West Virginia Code, §5A-3-37, provides an opportunity for qualifying vendors to request (at the time of bid) preference for their residency status. Such preference is an evaluation method only and will be applied only to the cost bid in accordance with the West Virginia Code. This certificate for application is to be used to request such preference. The Purchasing Division will make the determination of the Resident Vendor Preference, if applicable.

- 1. Application is made for 2.5% resident vendor preference for the reason checked: Bidder is an individual resident vendor and has resided continuously in West Virginia for four (4) years immediately preceding the date of this certification; or, Bidder is a partnership, association or corporation resident vendor and has maintained its headquarters or principal place of business continuously in West Virginia for four (4) years immediately preceding the date of this certification; or 80% of the ownership interest of Bidder is held by another individual, partnership, association or corporation resident vendor who has maintained its headquarters or principal place of business continuously in West Virginia for four (4) years immediately preceding the date of this certification; or, Bidder is a nonresident vendor which has an affiliate or subsidiary which employs a minimum of one hundred state residents and which has maintained its headquarters or principal place of business within West Virginia continuously for the four (4) years immediately preceding the date of this certification; or,
2. Application is made for 2.5% resident vendor preference for the reason checked: Bidder is a resident vendor who certifies that, during the life of the contract, on average at least 75% of the employees working on the project being bid are residents of West Virginia who have resided in the state continuously for the two years immediately preceding submission of this bid; or,
3. Application is made for 2.5% resident vendor preference for the reason checked: Bidder is a nonresident vendor employing a minimum of one hundred state residents or is a nonresident vendor with an affiliate or subsidiary which maintains its headquarters or principal place of business within West Virginia employing a minimum of one hundred state residents who certifies that, during the life of the contract, on average at least 75% of the employees or Bidder's affiliate's or subsidiary's employees are residents of West Virginia who have resided in the state continuously for the two years immediately preceding submission of this bid; or,
4. Application is made for 5% resident vendor preference for the reason checked: Bidder meets either the requirement of both subdivisions (1) and (2) or subdivision (1) and (3) as stated above; or,
5. Application is made for 3.5% resident vendor preference who is a veteran for the reason checked: Bidder is an individual resident vendor who is a veteran of the United States armed forces, the reserves or the National Guard and has resided in West Virginia continuously for the four years immediately preceding the date on which the bid is submitted; or,
6. Application is made for 3.5% resident vendor preference who is a veteran for the reason checked: Bidder is a resident vendor who is a veteran of the United States armed forces, the reserves or the National Guard, if, for purposes of producing or distributing the commodities or completing the project which is the subject of the vendor's bid and continuously over the entire term of the project, on average at least seventy-five percent of the vendor's employees are residents of West Virginia who have resided in the state continuously for the two immediately preceding years.

Bidder understands if the Secretary of Revenue determines that a Bidder receiving preference has failed to continue to meet the requirements for such preference, the Secretary may order the Director of Purchasing to: (a) reject the bid; or (b) assess a penalty against such Bidder in an amount not to exceed 5% of the bid amount and that such penalty will be paid to the contracting agency or deducted from any unpaid balance on the contract or purchase order.

By submission of this certificate, Bidder agrees to disclose any reasonably requested information to the Purchasing Division and authorizes the Department of Revenue to disclose to the Director of Purchasing appropriate information verifying that Bidder has paid the required business taxes, provided that such information does not contain the amounts of taxes paid nor any other information deemed by the Tax Commissioner to be confidential.

Under penalty of law for false swearing (West Virginia Code, §61-5-3), Bidder hereby certifies that this certificate is true and accurate in all respects; and that if a contract is issued to Bidder and if anything contained within this certificate changes during the term of the contract, Bidder will notify the Purchasing Division in writing immediately.

Bidder: OM OFFICE SUPPLY INC Signed: [Signature]

Date: 07/8/2011 Title: V.P

*Check any combination of preference consideration(s) indicated above, which you are entitled to receive.

RFQ No. DRB11212

STATE OF WEST VIRGINIA
Purchasing Division

PURCHASING AFFIDAVIT

West Virginia Code §5A-3-10a states: No contract or renewal of any contract may be awarded by the state or any of its political subdivisions to any vendor or prospective vendor when the vendor or prospective vendor or a related party to the vendor or prospective vendor is a debtor and the debt owed is an amount greater than one thousand dollars in the aggregate.

DEFINITIONS:

"Debt" means any assessment, premium, penalty, fine, tax or other amount of money owed to the state or any of its political subdivisions because of a judgment, fine, permit violation, license assessment, defaulted workers' compensation premium, penalty or other assessment presently delinquent or due and required to be paid to the state or any of its political subdivisions, including any interest or additional penalties accrued thereon.

"Debtor" means any individual, corporation, partnership, association, limited liability company or any other form or business association owing a debt to the state or any of its political subdivisions. "Political subdivision" means any county commission; municipality; county board of education; any instrumentality established by a county or municipality; any separate corporation or instrumentality established by one or more counties or municipalities, as permitted by law; or any public body charged by law with the performance of a government function or whose jurisdiction is coextensive with one or more counties or municipalities. "Related party" means a party, whether an individual, corporation, partnership, association, limited liability company or any other form or business association or other entity whatsoever, related to any vendor by blood, marriage, ownership or contract through which the party has a relationship of ownership or other interest with the vendor so that the party will actually or by effect receive or control a portion of the benefit, profit or other consideration from performance of a vendor contract with the party receiving an amount that meets or exceeds five percent of the total contract amount.

EXCEPTION: The prohibition of this section does not apply where a vendor has contested any tax administered pursuant to chapter eleven of this code, workers' compensation premium, permit fee or environmental fee or assessment and the matter has not become final or where the vendor has entered into a payment plan or agreement and the vendor is not in default of any of the provisions of such plan or agreement.

Under penalty of law for false swearing (*West Virginia Code* §61-5-3), it is hereby certified that the vendor affirms and acknowledges the information in this affidavit and is in compliance with the requirements as stated.

WITNESS THE FOLLOWING SIGNATURE

Vendor's Name: OM OFFICE SUPPLY INC

Authorized Signature: [Signature] Date: 6/27/11

State of PA

County of Cumberland, to-wit:

Taken, subscribed, and sworn to before me this 23 day of June, 2011.

My Commission expires Jan 11, 2014

AFFIX SEAL HERE

NOTARY PUBLIC [Signature]

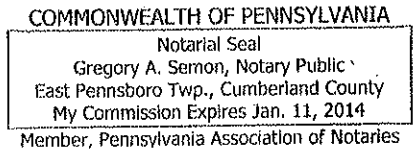



OM Office Supply Inc.
5007 Carlisle Pike
Mechanicsburg, PA 17050
Tel: 717-763-4216

JLE37BC3001
BlackCrystal™ E-LED 3001 HDTV

www.jvc.com

37" Class
Full HD 1080p
LED-LCD HDTV

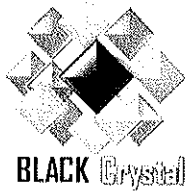

SRS
StudioSound **HD**



Key Features:

- Full HD 1080p Resolution
- Edge LED Backlit
- 2M:1 Contrast Ratio
- XinemaSound™ System And SRS StudioSound HD™
- Dolby Digital 5.1
- CrystalColor™ Enhancement
- USB Multimedia Support
- Ambient Light Sensor
- Audio Only Mode
- Auto Power Off (DPMS)
- HDMI-CEC, HDMI-ARC

Input/Output & Measurements

- 3 HDMI (v1.4) Inputs
- 1 Component/Composite Input
- 1 PC Input (VGA) Inputs
- 1 Music Port/PC Audio Input
- 1 USB Port
- 1 RF Antenna Input
- 1 Optical Digital Audio Output
- 1 Stereo Audio Output

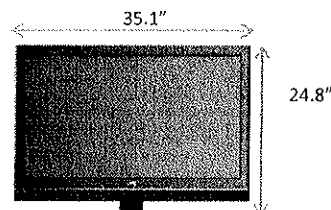

Weight: 19.8 lbs (without Stand)
21.1 lbs (with Stand)

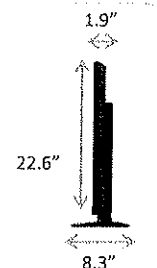

Sales Contact: avc.sales@jvc.com | 1 (855) 868 1926

Version: 1.2

Specifications are subject to change without notice



BLACK Crystal

OM Office Supply Inc
 5007 Carlisle Pike
 Mechanicsburg, PA 17050
 Tel: 717-763-4216

JLE37BC3001
 BlackCrystal™ E-LED 3001 HDTV

www.jvc.com

Model Name	JLE32BC3001	JLE37BC3001	JLE42BC3001	JLE47BC3001	
Panel					
Size Class (Diagonal)	32"	37"	42"	47"	
Panel/Resolution/Aspect	FHD 1920x1080 / 16:9				
Backlit	E-LED				
Refresh Rate	60Hz		120Hz CrystalMotion™		
Brightness (nits)	500				
Contrast Ratio	2M:1 (Dynamic)				
Audio Features					
Audio Technology	Dolby Digital 5.1 Decode, Xinema Sound™ w/SRS StudioSound HD™				
Audio Output Power	20W (10W x 2) Front Firing speakers				
MTS decode/Graphic Equalizer	Yes				
TV Features					
Color Enhancement	Yes, CrystalColor™				
PIP/POP	No		Yes		
Picture Mode	6 picture mode, plus multiple customizable modes				
Built in tuner/Close Caption/Parental Control	Yes				
Game Mode	Yes				
Convenience Features					
Ambient Light Sensor	Yes				
Auto Power Off (DPMS)	Yes, all inputs				
HDMI-CEC	Yes, all HDMI ports				
HDMI-ARC	Yes, HDMI 1				
Audio Only Mode	Yes (Backlit turn off)				
Interactive Setup Guide	Yes				
Input Port Naming	Yes				
Multimedia Support (via USB)	JPEG		JPEG, MP3 & Video		
Others					
Remote	IR				
Energy Star Certified	Yes v5.3				
Input	Antenna In	1	1	1	1
	HDMI v.1.4	3	3	4	4
	Component /Composite (share)	1	1	1	1
	VGA/RGB	1	1	1	1
	Music port (share with PC audio port)	1	1	1	1
	USB	1	1	2	2
Output	Digital Audio Out	1	1	1	1
	Stereo Audio Out	1	1	1	1
Mechanical	Depth (w/o stand)	1.9"	1.9"	2.2"	2"
	Wall Mount	VESA 200 (200x200mm)	VESA 200 (200x200mm)	VESA 400 (400x200mm)	VESA 400 (400x200mm)

Sales Contact: avc.sales@jvc.com | 1 (855) 868 1926

Version: 1.2

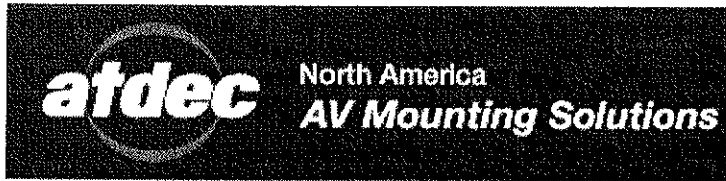

VISIT OUR GLOBAL SITE | CREA

- HOME
- ABOUT US
- DEALER APPLICATION
- CUSTOMER CARE
- RESELLERS
- MOUNT FINDER
- BLO

Mounts

Atdec > Mounts > TV Wall Mounts

All flat screen mounts

Telehook TH-3070-UT

Cable Management

INSTALLATION GUIDE

PRODUCT BROCHURE



TECI

Ceiling Mounts

OM Office Supply Inc.
5007 Carlisle Pike
Mechanicsburg, PA 17050
Tel: 717-763-4216

Laptop Stands

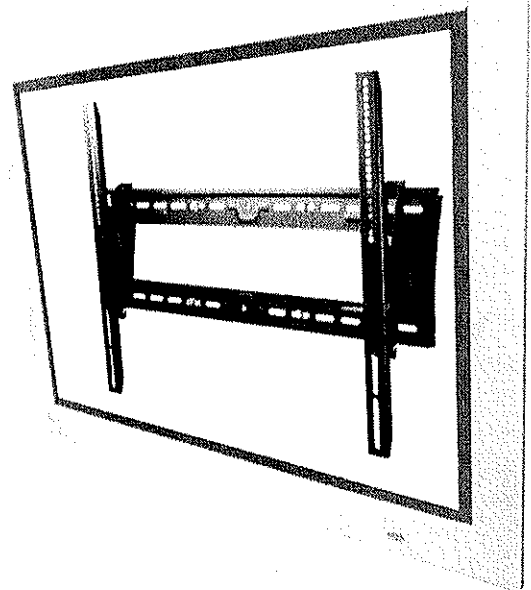

Mobile Carts

Monitor Arms

Monitor Stands

Mounting Accessories

Multi Screen Mounts

Projector Mounts

TV Wall Mounts

Ultra Slim TV Wall Mounts

Search by Atdec brand

Visidec

Spacedec

Telehook

Coming soon

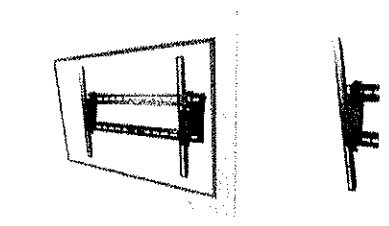
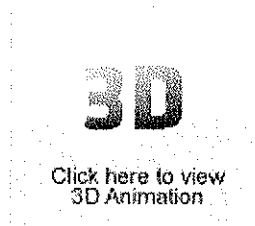

Click here to view our 60 DAY Returns Policy

Product	Availability	Price	QTY
---------	--------------	-------	-----

Clearance Stock

Telehook TH-3070-UT IN STOCK \$99.00 1



KEY FEATURES
REVIEWS
ADD YOUR REVIEW

Highly durable and extremely strong, the TH 3070-UT supports displays that weigh up to 200lbs (91kg). Very simple to install, the TH 3070-UT is 3" (76mm) from the wall for a display that's streamlined as well as easy to view. Even after installation, height can be altered and tilt adjusted up to 15 degrees. This is an essential feature for monitoring multiple monitors to provide a viewing angle with optimum picture clarity and impact.

Max display weight:	200lbs
VESA:	Universal
Mounting Hole Pattern (mm):	From 180-800 Width x 180-500 Height
	200x100;200x200;200x300;300x300;400x300;400x400;600x400;800x200;800x400
Standard VESA Hole Pattern (mm):	

Distance from wall to the rear of display:	3"
Tilt adjustment:	-5° to +15°
Number of studs required:	0
Display tilt adjustment:	5 degrees up and 15 degrees down in vertical plane
Dry wall installation:	Dry wall anchors included
Hardware required for installation:	All mounting hardware included
Color:	Black

10 years if purchased after January 1, 2011

Warranty:



OM Office Supply Inc.
5007 Carlisle Pike
Mechanicsburg, PA 17050
Tel: 717-763-4216

© 2011 ATDEC
ALL RIGHTS RESERVED.

INTERESTED IN ATDEC PRODUCTS?

Find out more about monitor arms, tv wall mounts, no

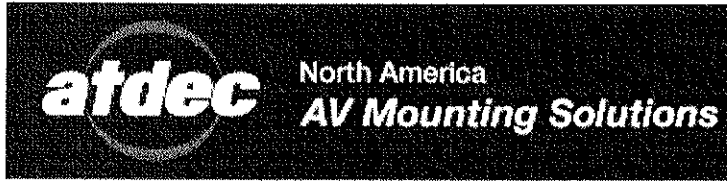

888 303 4252

VISIT OUR GLOBAL SITE | CREA

- HOME
- ABOUT US
- DEALER APPLICATION
- CUSTOMER CARE
- RESELLERS
- MOUNT FINDER
- BLO

Mounts

Atdec > Mounts > TV Wall Mounts

All flat screen mounts

Telehook TH-3270-UFM

Cable Management

INSTALLATION GUIDE

PRODUCT BROCHURE



TECH

Ceiling Mounts

Laptop Stands

Mobile Carts

OM Office Supply Inc.
 5007 Carlisle Pike
 Mechanicsburg, PA 17050
 Tel: 717-763-4216

Monitor Arms

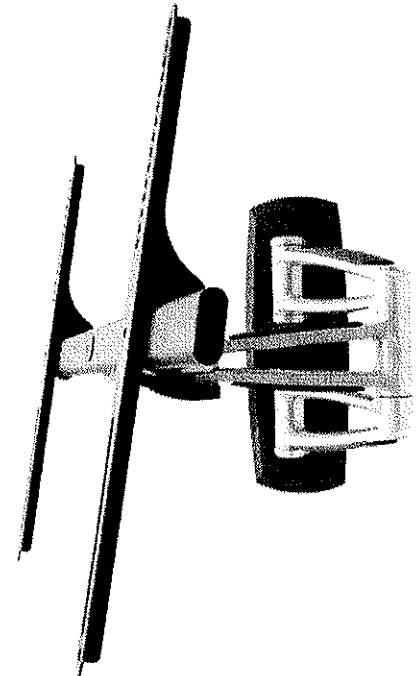

Monitor Stands

Mounting Accessories

Multi Screen Mounts

Projector Mounts

TV Wall Mounts

Ultra Slim TV Wall Mounts

Search by Atdec brand

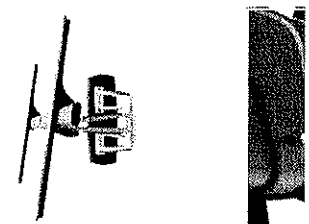
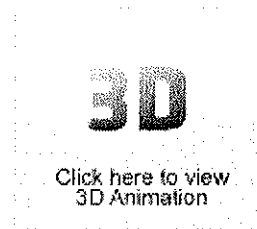

Visidec

Click here to view our 60 DAY Returns Policy

Spacedec

Telehook

Coming soon

Product

Availability

Price

QTY

Clearance Stock

Telehook TH-3270-UFM IN STOCK \$369.00 1



KEY FEATURES
REVIEWS
ADD YOUR REVIEW



The Telehook Universal Full Motion mount provides a highly articulated solution for attaching a large LED, LCD or Plasma screen to a wall. The highly articulated arm allows for a relatively flush seated screen in any position and pan adjustment. It features Atdec's Smooth Glide mechanism to ensure easy operation with even the heaviest and largest units. The display head allows tilt adjustment and rotation for smooth and comfortable operation. The high quality finish, cable management and hidden mounting points make this product suitable for both home and commercial use.

The TH-3270-UFM ships with an arm unit and mounting plate to the wall along with a bracket which attaches to the display hardware included in the pack. The bracket features Universal mounting holes to suit the widest possible range of screens with either VESA/standard mounting hole patterns (refer specifications below) when the display is lifted, slotted and secured into place with a lock. In situations where the screen is being used as a display device, the product allows display installation in either a landscape or portrait orientation. The product is designed for solid timber or masonry wall structures with all required hardware.

Note: Due to the spring loading on the tilt mechanism the product is most comfortably operated with displays which weigh 0

For a version to suit smaller/ lighter screens see TH-2050-VFM

For a direct wall attach solution with support for screen rotation see

Min screen size:	32"
Max display weight:	143lbs
Quick Release mounting head:	Yes (with security screw)

OM Office Supply Inc.
5007 Carlisle Pike
Mechanicsburg, PA 17050
Tel: 717-763-4216

Universal mounting pattern support (mm): 150-805 wide by 140-500 high (6-32" x 5.5-19.5")

Standard VESA mounting pattern support (mm): 200x100, 200x200, 200x300, 300x300, 400x300, 400x400; 600x400, 800x200, 800x400

OM Office Supply Inc.
 5007 Carlisle Pike
 Mechanicsburg, PA 17050
 Tel: 717-763-4216

Pan rotation at wall: +/-90°

Pan rotation at articulation: +/-180°

Pan rotation at head: +/-90°

Tilt adjustment: +10/-20° with spring loading

Horizontal adjustment: +/-5° for levelling

Screen orientation: Portrait or landscape (selectable during installation)

Cable management: Integrated

Mounting style: Wall

Minimum wall offset: 6.1"

Maximum reach: 25"

Number of studs required: 1

Product Contents: Shipped with installation guide, display mounting hardware and hardware for attachment to timber stud and masonry walls (not suitable for drywall)

Color: Silver with Black trim



10 years if purchased after Jan 1, 2011



Warranty:



©2011 ATDEC
 ALL RIGHTS RESERVED.

INTERESTED IN ATDEC PRODUCTS?

Find out more about monitor arms, tv wall mounts, no

- [CUSTOMER CARE](#)
- [SFP MAP](#)
- [WHY BUY ATDEC?](#)
- [MOUNT FINDER](#)
- [TERMS OF USE](#)

