



State of West Virginia
 Department of Administration
 Purchasing Division
 2019 Washington Street East
 Post Office Box 50130
 Charleston, WV 25305-0130

Request for Quotation

RFQ NUMBER
DNRB11212

PAGE
1

ADDRESS CORRESPONDENCE TO ATTENTION OF
FRANK WHITTAKER 304-558-2316

RFQ COPY
 TYPE NAME/ADDRESS HERE

Lee Hartman & Sons, Inc.
3 Davis Court
Hurricane, WV 25528
V 304-397-4100 F 304-397-4101

DIVISION OF NATURAL RESOURCES
 VARIOUS LOCALES AS INDICATED
 BY ORDER

DATE PRINTED	TERMS OF SALE	SHIP VIA	FOB	FREIGHT TERMS
06/16/2011	Net 30	Best way	Destination	FF&A

BID OPENING DATE: 07/20/2011 BID OPENING TIME 01:30PM

LINE	QUANTITY	LOP	CAT. NO	ITEM NUMBER	UNIT PRICE	AMOUNT
0001	1	LS		840-60		130,593.50
<p>FLAT SCREEN TELEVISIONS</p> <p>THE WEST VIRGINIA PURCHASING DIVISION, FOR THE AGENCY, THE WEST VIRGINIA DIVISION OF NATURAL RESOURCES IS SOLICITING BIDS FOR FLAT SCREEN TELEVISIONS AND MOUNTING HARDWARE FOR SEVERAL STATE PARKS, PER THE ATTACHED SPECIFICATIONS.</p> <p>ALL TECHNICAL QUESTIONS MUST BE SUBMITTED IN WRITING TO FRANK WHITTAKER IN THE WV PURCHASING DIVISION VIA EMAIL AT FRANK.M.WHITTAKER@WV.GOV OR VIA FAX AT 304-558-4115. DEADLINE FOR TECHNICAL QUESTIONS IS 06/28/2011 AT 4:00 PM. ALL TECHNICAL QUESTIONS WILL BE ADDRESSED BY ADDENDUM AFTER THE DEADLINE.</p> <p>EXHIBIT 4</p> <p>LOCAL GOVERNMENT BODIES: UNLESS THE VENDOR INDICATES IN THE BID HIS REFUSAL TO EXTEND THE PRICES, TERMS, AND CONDITIONS OF THE BID TO COUNTY, SCHOOL, MUNICIPAL AND OTHER LOCAL GOVERNMENT BODIES, THE BID SHALL EXTEND TO POLITICAL SUBDIVISIONS OF THE STATE OF WEST VIRGINIA. IF THE VENDOR DOES NOT WISH TO EXTEND THE PRICES, TERMS, AND CONDITIONS OF THE BID TO ALL POLITICAL SUBDIVISIONS OF THE STATE, THE VENDOR MUST CLEARLY INDICATE SUCH REFUSAL IN HIS BID. SUCH REFUSA</p>						

RECEIVED
 2011 JUL 20 AM 8:04
 W/...

SEE REVERSE SIDE FOR TERMS AND CONDITIONS			
SIGNATURE <i>Rory Tex</i>	TELEPHONE 304-397-4100	DATE 7/15/2011	
TITLE Area Manager	FEIN 540716361	ADDRESS CHANGES TO BE NOTED ABOVE	

WHEN RESPONDING TO RFQ, INSERT NAME AND ADDRESS IN SPACE ABOVE LABELED 'VENDOR'

GENERAL TERMS & CONDITIONS REQUEST FOR QUOTATION (RFQ) AND REQUEST FOR PROPOSAL (RFP)

1. Awards will be made in the best interest of the State of West Virginia.
2. The State may accept or reject in part, or in whole, any bid.
3. Prior to any award, the apparent successful vendor must be properly registered with the Purchasing Division and have paid the required \$125 fee.
4. All services performed or goods delivered under State Purchase Order/Contracts are to be continued for the term of the Purchase Order/Contracts, contingent upon funds being appropriated by the Legislature or otherwise being made available. In the event funds are not appropriated or otherwise available for these services or goods this Purchase Order/Contract becomes void and of no effect after June 30.
5. Payment may only be made after the delivery and acceptance of goods or services.
6. Interest may be paid for late payment in accordance with the *West Virginia Code*.
7. Vendor preference will be granted upon written request in accordance with the *West Virginia Code*.
8. The State of West Virginia is exempt from federal and state taxes and will not pay or reimburse such taxes.
9. The Director of Purchasing may cancel any Purchase Order/Contract upon 30 days written notice to the seller.
10. The laws of the State of West Virginia and the *Legislative Rules* of the Purchasing Division shall govern the purchasing process.
11. Any reference to automatic renewal is hereby deleted. The Contract may be renewed only upon mutual written agreement of the parties.
12. **BANKRUPTCY:** In the event the vendor/contractor files for bankruptcy protection, the State may deem this contract null and void, and terminate such contract without further order.
13. **HIPAA BUSINESS ASSOCIATE ADDENDUM:** The West Virginia State Government HIPAA Business Associate Addendum (BAA), approved by the Attorney General, is available online at www.state.wv.us/admin/purchase/vrc/hipaa.htm and is hereby made part of the agreement. Provided that the Agency meets the definition of a Cover Entity (45 CFR §160.103) and will be disclosing Protected Health Information (45 CFR §160.103) to the vendor.
14. **CONFIDENTIALITY:** The vendor agrees that he or she will not disclose to anyone, directly or indirectly, any such personally identifiable information or other confidential information gained from the agency, unless the individual who is the subject of the information consents to the disclosure in writing or the disclosure is made pursuant to the agency's policies, procedures, and rules. Vendor further agrees to comply with the Confidentiality Policies and Information Security Accountability Requirements, set forth in <http://www.state.wv.us/admin/purchase/privacy/noticeConfidentiality.pdf>.
15. **LICENSING:** Vendors must be licensed and in good standing in accordance with any and all state and local laws and requirements by any state or local agency of West Virginia, including, but not limited to, the West Virginia Secretary of State's Office, the West Virginia Tax Department, and the West Virginia Insurance Commission. The vendor must provide all necessary releases to obtain information to enable the director or spending unit to verify that the vendor is licensed and in good standing with the above entities.
16. **ANTITRUST:** In submitting a bid to any agency for the State of West Virginia, the bidder offers and agrees that if the bid is accepted the bidder will convey, sell, assign or transfer to the State of West Virginia all rights, title and interest in and to all causes of action it may now or hereafter acquire under the antitrust laws of the United States and the State of West Virginia for price fixing and/or unreasonable restraints of trade relating to the particular commodities or services purchased or acquired by the State of West Virginia. Such assignment shall be made and become effective at the time the purchasing agency tenders the initial payment to the bidder.

I certify that this bid is made without prior understanding, agreement, or connection with any corporation, firm, limited liability company, partnership, or person or entity submitting a bid for the same material, supplies, equipment or services and is in all respects fair and without collusion or fraud. I further certify that I am authorized to sign the certification on behalf of the bidder or this bid.

INSTRUCTIONS TO BIDDERS

1. Use the quotation forms provided by the Purchasing Division. Complete all sections of the quotation form.
2. Items offered must be in compliance with the specifications. Any deviation from the specifications must be clearly indicated by the bidder. Alternates offered by the bidder as **EQUAL** to the specifications must be clearly defined. A bidder offering an alternate should attach complete specifications and literature to the bid. The Purchasing Division may waive minor deviations to specifications.
3. Unit prices shall prevail in case of discrepancy. All quotations are considered F.O.B. destination unless alternate shipping terms are clearly identified in the quotation.
4. All quotations must be delivered by the bidder to the office listed below prior to the date and time of the bid opening. Failure of the bidder to deliver the quotations on time will result in bid disqualifications: Department of Administration, Purchasing Division, 2019 Washington Street East, P.O. Box 50130, Charleston, WV 25305-0130
5. Communication during the solicitation, bid, evaluation or award periods, except through the Purchasing Division, is strictly prohibited (W.Va. C.S.R. §148-1-6.6).



State of West Virginia
 Department of Administration
 Purchasing Division
 2019 Washington Street East
 Post Office Box 50130
 Charleston, WV 25305-0130

**Request for
 Quotation**

BFO NUMBER
DNRB11212

PAGE
2

ADDRESS CORRESPONDENCE TO ATTENTION OF
**FRANK WHITTAKER
 304-558-2316**

RFQ COPY
 TYPE NAME/ADDRESS HERE

**Lee Hartman & Sons, Inc.
 3 Davis Court
 Hurricane, WV 25526
 V 304-397-4100 F 304-397-4101**

DIVISION OF NATURAL RESOURCES
 VARIOUS LOCALES AS INDICATED
 BY ORDER

DATE PRINTED	TERMS OF SALE	SHIP VIA	F.O.B.	FREIGHT TERMS
06/16/2011	Net 30	Best way	Destination	Prepaid
BID OPENING DATE: 07/20/2011		BID OPENING TIME 01:30PM		

LINE	QUANTITY	UOP	CAT NO	ITEM NUMBER	UNIT PRICE	AMOUNT
<p>SHALL NOT PREJUDICE THE AWARD OF THIS CONTRACT IN ANY MANNER.</p> <p>REV. 3/88 EXHIBIT 3</p> <p>LIFE OF CONTRACT: THIS CONTRACT BECOMES EFFECTIVE ON AND EXTENDS FOR A PERIOD OF ONE (1) YEAR OR UNTIL SUCH "REASONABLE TIME" THEREAFTER AS IS NECESSARY TO OBTAIN A NEW CONTRACT OR RENEW THE ORIGINAL CONTRACT. THE "REASONABLE TIME" PERIOD SHALL NOT EXCEED TWELVE (12) MONTHS. DURING THIS "REASONABLE TIME" THE VENDOR MAY TERMINATE THIS CONTRACT FOR ANY REASON UPON GIVING THE DIRECTOR OF PURCHASING 30 DAYS WRITTEN NOTICE.</p> <p>UNLESS SPECIFIC PROVISIONS ARE STIPULATED ELSEWHERE IN THIS CONTRACT DOCUMENT, THE TERMS, CONDITIONS AND PRICING SET HEREIN ARE FIRM FOR THE LIFE OF THE CONTRACT.</p> <p>RENEWAL: THIS CONTRACT MAY BE RENEWED UPON THE MUTUAL WRITTEN CONSENT OF THE SPENDING UNIT AND VENDOR, SUBMITTED TO THE DIRECTOR OF PURCHASING THIRTY (30) DAYS PRIOR TO THE EXPIRATION DATE. SUCH RENEWAL SHALL BE IN ACCORDANCE WITH THE TERMS AND CONDITIONS OF THE ORIGINAL CONTRACT AND SHALL BE LIMITED TO TWO (2) ONE (1) YEAR PERIODS.</p> <p>CANCELLATION: THE DIRECTOR OF PURCHASING RESERVES THE RIGHT TO CANCEL THIS CONTRACT IMMEDIATELY UPON WRITTEN NOTICE TO THE VENDOR IF THE COMMODITIES AND/OR SERVICES SUPPLIED ARE OF AN INFERIOR QUALITY OR DO NOT CONFORM TO THE SPECIFICATIONS OF THE BID AND CONTRACT HEREIN.</p> <p>OPEN MARKET CLAUSE: THE DIRECTOR OF PURCHASING MAY</p>						

SEE REVERSE SIDE FOR TERMS AND CONDITIONS

SIGNATURE <i>Darryl Ex</i>	TELEPHONE 304-397-4100	DATE 7-15-2011
TITLE Area Manager	FEIN 540716361	ADDRESS CHANGES TO BE NOTED ABOVE

WHEN RESPONDING TO RFQ, INSERT NAME AND ADDRESS IN SPACE ABOVE LABELED 'VENDOR'



State of West Virginia
 Department of Administration
 Purchasing Division
 2019 Washington Street East
 Post Office Box 50130
 Charleston, WV 25305-0130

Request for Quotation

RFQ NUMBER
DNRB11212

PAGE
3

ADDRESS CORRESPONDENCE TO ATTENTION OF
FRANK WHITTAKER 304-558-2316

RFQ COPY
 TYPE NAME/ADDRESS HERE
Lee Hartman & Sons, Inc.
3 Davis Court
Hurricane, WV 25526
V 304-397-4100 F 304-397-4101

VENDOR

SHIP TO

DIVISION OF NATURAL RESOURCES
 VARIOUS LOCALES AS INDICATED
 BY ORDER

DATE PRINTED	TERMS OF SALE	SHIP VIA	F.O.B.	FREIGHT TERMS
06/16/2011	Net 30	Best way	Destination	FF & A

BID OPENING DATE: **07/20/2011** BID OPENING TIME **01:30PM**

LINE	QUANTITY	UOP	CAT NO	ITEM NUMBER	UNIT PRICE	AMOUNT
<p>AUTHORIZE A SPENDING UNIT TO PURCHASE ON THE OPEN MARKET, WITHOUT THE FILING OF A REQUISITION OR COST ESTIMATE, ITEMS SPECIFIED ON THIS CONTRACT FOR IMMEDIATE DELIVERY IN EMERGENCIES DUE TO UNFORESEEN CAUSES (INCLUDING BUT NOT LIMITED TO DELAYS IN TRANSPORTATION OR AN UNANTICIPATED INCREASE IN THE VOLUME OF WORK.)</p> <p>QUANTITIES: QUANTITIES LISTED IN THE REQUISITION ARE APPROXIMATIONS ONLY, BASED ON ESTIMATES SUPPLIED BY THE STATE SPENDING UNIT. IT IS UNDERSTOOD AND AGREED THAT THE CONTRACT SHALL COVER THE QUANTITIES ACTUALLY ORDERED FOR DELIVERY DURING THE TERM OF THE CONTRACT, WHETHER MORE OR LESS THAN THE QUANTITIES SHOWN.</p> <p>ORDERING PROCEDURE: SPENDING UNIT(S) SHALL ISSUE A WRITTEN STATE CONTRACT ORDER (FORM NUMBER WV-39) TO THE VENDOR FOR COMMODITIES COVERED BY THIS CONTRACT. THE ORIGINAL COPY OF THE WV-39 SHALL BE MAILED TO THE VENDOR AS AUTHORIZATION FOR SHIPMENT, A SECOND COPY MAILED TO THE PURCHASING DIVISION, AND A THIRD COPY RETAINED BY THE SPENDING UNIT.</p> <p>BANKRUPTCY: IN THE EVENT THE VENDOR/CONTRACTOR FILES FOR BANKRUPTCY PROTECTION, THE STATE MAY DEEM THE CONTRACT NULL AND VOID, AND TERMINATE SUCH CONTRACT WITHOUT FURTHER ORDER.</p> <p>THE TERMS AND CONDITIONS CONTAINED IN THIS CONTRACT SHALL SUPERSEDE ANY AND ALL SUBSEQUENT TERMS AND CONDITIONS WHICH MAY APPEAR ON ANY ATTACHED PRINTED DOCUMENTS SUCH AS PRICE LISTS, ORDER FORMS, SALES AGREEMENTS OR MAINTENANCE AGREEMENTS, INCLUDING ANY ELECTRONIC MEDIUM SUCH AS CD-ROM.</p> <p>REV. 05/26/2009</p>						

SEE REVERSE SIDE FOR TERMS AND CONDITIONS			
SIGNATURE	TELEPHONE	DATE	
<i>Raymond J. Cox</i>	304-397-4100	7-15-2011	
TITLE	FEIN	ADDRESS CHANGES TO BE NOTED ABOVE	
Area Manager	540716361		

WHEN RESPONDING TO RFQ, INSERT NAME AND ADDRESS IN SPACE ABOVE LABELED 'VENDOR'



State of West Virginia
 Department of Administration
 Purchasing Division
 2019 Washington Street East
 Post Office Box 50130
 Charleston, WV 25305-0130

Request for Quotation

RFQ NUMBER
DNRB11212

PAGE
4

ADDRESS CORRESPONDENCE TO ATTENTION OF
FRANK WHITTAKER
304-558-2316

RFQ COPY
 TYPE NAME/ADDRESS HERE

Lee Hartman & Sons, Inc.
3 Davis Court
Hurricane, WV 25526
V 304-397-4100 F 304-397-4101

DIVISION OF NATURAL RESOURCES
VARIOUS LOCALES AS INDICATED
BY ORDER

DATE PRINTED 06/16/2011	TERMS OF SALE Net 30	SHIP VIA Best way	F.O.B. Destination	FREIGHT TERMS C.O.D.
BID OPENING DATE: 07/20/2011		BID OPENING TIME 01:30PM		

LINE	QUANTITY	UOP	CAT. NO.	ITEM NUMBER	UNIT PRICE	AMOUNT
NOTICE A SIGNED BID MUST BE SUBMITTED TO: DEPARTMENT OF ADMINISTRATION PURCHASING DIVISION BUILDING 15 2019 WASHINGTON STREET, EAST CHARLESTON, WV 25305-0130 THE BID SHOULD CONTAIN THIS INFORMATION ON THE FACE OF THE ENVELOPE OR THE BID MAY NOT BE CONSIDERED: SEALED BID BUYER: 44 RFQ. NO.: DNRB11212 BID OPENING DATE: 7/20/2011 BID OPENING TIME: 1:30 PM PLEASE PROVIDE A FAX NUMBER IN CASE IT IS NECESSARY TO CONTACT YOU REGARDING YOUR BID: ----- 304-397-4101 ----- CONTACT PERSON (PLEASE PRINT CLEARLY):						

SEE REVERSE SIDE FOR TERMS AND CONDITIONS

SIGNATURE <i>Randy M Cox</i>	TELEPHONE 304-397-4100	DATE 7-15-2011
TITLE Area Manager	FEIN 540716361	ADDRESS CHANGES TO BE NOTED ABOVE

WHEN RESPONDING TO RFQ, INSERT NAME AND ADDRESS IN SPACE ABOVE LABELED 'VENDOR'



State of West Virginia
 Department of Administration
 Purchasing Division
 2019 Washington Street East
 Post Office Box 50130
 Charleston, WV 25305-0130

Request for Quotation

BID NUMBER
DNRB11212

PAGE
5

ADDRESS CORRESPONDENCE TO ATTENTION OF
FRANK WHITTAKER 304-558-2316

RFQ COPY
 TYPE NAME/ADDRESS HERE
Lee Hartman & Sons, Inc.
3 Davis Court
Hurricane, WV 25526
V 304-397-4100 F 304-397-4101

DIVISION OF NATURAL RESOURCES
 VARIOUS LOCALES AS INDICATED
 BY ORDER

VENDOR

SHIP TO

DATE PRINTED	TERMS OF SALE	SHIP VIA	FOB	FREIGHT TERMS
06/16/2011	Net 30	Best way	Destination	P P A
BID OPENING DATE: 07/20/2011		BID OPENING TIME 01:30PM		

LINE	QUANTITY	UOP	CAT NO	ITEM NUMBER	UNIT PRICE	AMOUNT
				Larry T. Cox		
***** THIS IS THE END OF RFQ DNRB11212 ***** TOTAL:						\$130,593.50

SEE REVERSE SIDE FOR TERMS AND CONDITIONS		
SIGNATURE <i>Larry T. Cox</i>	TELEPHONE 304-397-4100	DATE 7-15-2011
TITLE Area Manager	FEIN 540716361	ADDRESS CHANGES TO BE NOTED ABOVE

WHEN RESPONDING TO RFQ, INSERT NAME AND ADDRESS IN SPACE ABOVE LABELED 'VENDOR'

OPEN END AGENCY CONTRACT Televisions

The West Virginia Division of Natural Resources is requesting Bids for an open ended contract for the purchase of flat screen televisions to be utilized for upgrades and redecoration of parks in various locations. All items are to be shipped FOB Destination. Vendor shall be required to submit a Bill of Lading for all material and items shipped that clearly show actual shipping costs.

General Specifications:

All items must be new, and must be Energy Star qualified. Televisions must be flat screen, and must have the availability to be mounted securely on the wall with appropriate wall mounting systems.

Basis of Award:

This contract is split into three separate bids based upon the location of the park where these items will be initially purchased. The three locations are Blackwater Falls State Park, Davis, WV, Pipestem Resort State Park, Pipestem, WV and Tygart Lake State Park, Grafton, WV.

Vendors may bid on any or all locations.

The television package will be awarded to the lowest qualified Bidder submitting the lowest Bid for all televisions and mounting hardware at each location, as stipulated on the Bid schedule and in complete accordance with all specifications stipulated herein. Partial or conditional bids will not be considered.

Coordination:

Vendor must coordinate shipping and receiving with each park. All items must be received within thirty days of the issuance of a purchase order.

Delivery, Storage and Handling:

The successful Vendor must deliver and handle all items according to Manufacturer's recommendations, including means and methods that will prevent damage, deterioration, and loss. Goods must be delivered in the Manufacturer's original sealed containers complete with labels and instructions for handling, storage, unpacking, protecting, and installing. The Division will supply labor to inspect the goods upon delivery, to ensure compliance with the purchase order, and to ensure all items are undamaged and protected against damage. All items must be delivered according to Manufacturer's recommendations and in an order that will facilitate inspection and measurement of quantity. All items must be delivered using means and methods that will prevent damage, deterioration, theft, or other loss. All items are to be shipped FOB Destination. Vendor shall be required to submit a Bill of Lading for all material and items shipped that clearly show actual shipping costs.

Locations:
BLACKWATER FALLS STATE PARK
(Tucker County)
RR 29 Drawer 490
Davis, WV 26260-0490

PIPESTEM RESORT STATE PARK
(Summers County)
RR 20 Box 150
Pipestem, WV 25979-0150

TYGART LAKE STATE PARK
(Taylor County)
RR 1 Box 260
Grafton, WV 26354-9741

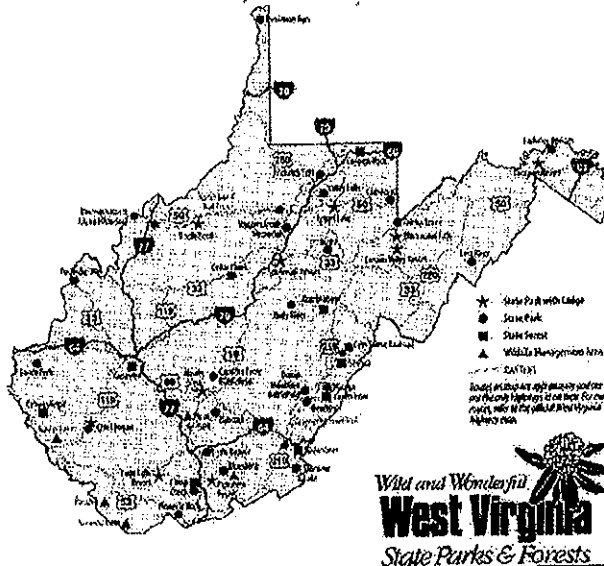

Damaged Items:

All items will be inspected by the Division at time of delivery to ensure that each item is not damaged or defective. Damaged or defective items will be rejected, and must be removed, and replaced at no additional expense to the Division.

Project Closeout:

Vendor must provide an inventory list of all items received and accepted. Vendor must provide the manufacturers recommendations for maintenance and cleaning.

Applications for Payment:

Vendor must submit Applications for Payment upon completion of delivery for all items delivered and accepted and upon completion of project closeout requirements.

Warranty:

The Vendor must warranty products to be free of defects in materials and Workmanship for a minimum period of one (1) year after date of acceptance or through manufacturer's provided warranty, whichever is greater. Vendor must repair or replace at its discretion, free of charge, any product that proves to be defective during the warranty period.

Estimated Quantities:

The quantities listed in this bid form are for bid evaluation purposes only – Actual quantities ordered may differ.

Television Specifications:

All items must meet the minimum specifications as detailed herein.
All items are to be shipped FOB Destination. Vendor shall be required to submit a Bill of Lading for all material and items shipped that clearly show actual shipping costs.

BLACKWATER FALLS STATE PARK

TELEVISION

Panasonic 42" Class 1080p LCD Model TH-42LRU30, or equal

- Must be minimum 42" Diagonal
- Minimum dimensions must be 25.1"x40.2"x4.2"
- Must be VESA mount compliant
- Must be LCD
- Must come with standard remote control
- Must have minimum contrast ratio of 20,000:1
- Must be model year 2010 or greater
- Minimum native resolution must be (1920 x 1080)
- Must have minimum 2 surround sound, full-range speakers
- Must have built in close caption decoder
- Must have sleep-off-timers and programmable timer
- Must be Energy Star® qualified

UNIVERSAL MOUNT WITH TILT

OmniMount 2N1-L, or equal

- Must be compatible with LCD Television provided under this contract
- Must fit a minimum of 37" – maximum 63" flat panel televisions
- Must support a minimum of 175 lbs
- Maximum tilt 15°
- Minimum mounting profile must be 2.7"
- Must be VESA compliant W200xH200

UNIVERSAL MOUNT WITH TILT / SWIVEL

OmniMount UCL-L, or equal

- Must be compatible with LCD Television provided under this contract
- Must fit a minimum of 37" – maximum 52" flat panel televisions
- Must support a minimum of 125 lbs.

OPEN END CONTRACT TELEVISIONS

- Must provide a minimum tilt -5° to a maximum tilt of 15°
- Minimum mounting profile must be 4.69"
- Maximum extension must be 26.8"
- Must be VESA compliant W200xH200

PIPESTEM RESORT STATE PARK

TELEVISION

LG 32" LCD TELEVISION 32LK330, or equal

- Must be minimum 31.5" Diagonal
- Must be LED
- Must have minimum contrast ratio of 70,000:1
- Minimum dimensions must be 31.5 X 22.2 X 8.1" (with stand)
- Must come with minimum 20° / 20° swivel stand
- Must come with standard remote control
- Must be model year 2010 or greater
- Minimum native resolution must be (1366x768)
- Must be Energy Star® qualified

TYGART LAKE STATE PARK

TELEVISION

LG 37" LED TELEVISION 37LV3500, or equal

- Must be minimum 37" Diagonal
- Must be LED
- Must have minimum contrast ratio of 3,000,000:1
- Minimum dimensions must be 24.9x20.9x1.6"
- Must be VESA mount compliant
- Must come with standard remote control
- Must be model year 2010 or greater
- Minimum native resolution must be (1920x1080)
- Must be Energy Star® qualified

TELEVISION

LG 55" LED TELEVISION 55LV5500, or equal

- Must be minimum 54.6" Diagonal
- Must be LED
- Must have minimum contrast ratio of 5,000,000:1
- Minimum dimensions must be 51.1"x30.6"x1.2"
- Must be VESA mount compliant
- Must come with standard remote control
- Must be model year 2010 or greater
- Minimum native resolution must be (1920x1080)
- Must be Energy Star® qualified

UNIVERSAL MOUNT WITH TILT

OmniMount 2N1-L, or equal

- Must be compatible with LED Television provided under this contract
- Must fit a minimum of 37" – maximum 63" flat panel televisions
- Must support a minimum of 175 lbs

OPEN END CONTRACT TELEVISIONS

- Maximum tilt 15°
- Minimum mounting profile must be 2.7"
- Must be VESA compliant

UNIVERSAL MOUNT WITH TILT / SWIVEL

OmniMount LEDP75, or equal

- Must be compatible with LED Television provided under this contract
- Must fit a minimum of 23" – maximum 60" flat panel televisions
- Must support a minimum of 75 lbs
- Minimum tilt -10° to maximum tilt 10°
- Minimum mounting profile: 0.6" in-wall; 2.23" on-wall
- Minimum lateral shift 11.35"
- Must be VESA compliant

BID FORM - TELEVISIONS
PIPESTEM RESORT STATE PARK

Item No.	Description	ESTIMATED QUANTITY	UNIT PRICE	EXTENDED PRICE
1	32" LCD TELEVISION	132	\$ 340.00	\$ 44,880.00
TOTAL BID				\$ 44,880.00

All items are to be shipped FOB Destination. Vendor shall be required to submit a Bill of Lading for all material and items shipped that clearly show actual shipping costs.

THE QUANTITIES LISTED ABOVE ARE FOR BID EVALUATION PURPOSES ONLY. ACTUAL QUANTITIES MAY DIFFER

BID FORM - TELEVISIONS
BLACKWATER FALLS STATE PARK

Item No.	Description	ESTIMATED QUANTITY	UNIT PRICE	EXTENDED PRICE
1	42" LCD TELEVISION	74	\$ 825.00	\$ 61,050.00
2	UNIVERSAL MOUNT WITH TILT	70	\$ 76.00	\$ 5,320.00
3	UNIVERSAL MOUNT WITH TILT / SWIVEL	4	\$ 260.00	\$ 1,040.00
TOTAL BID				\$ 67,410.00

All items are to be shipped FOB Destination. Vendor shall be required to submit a Bill of Lading for all material and items shipped that clearly show actual shipping costs.

THE QUANTITIES LISTED ABOVE ARE FOR BID EVALUATION PURPOSES ONLY. ACTUAL QUANTITIES MAY DIFFER.

BID FORM - TELEVISIONS
TYGART LAKE STATE PARK

Item No.	Description	ESTIMATED QUANTITY	UNIT PRICE	EXTENDED PRICE
1	37" LED TELEVISION	21	\$ 623.50	\$ 13,093.50
2	55" LED TELEVISION	2	\$ 1,547.00	\$ 3,094.00
3	UNIVERSAL MOUNT WITH TILT	21	\$ 76.00	\$ 1,596.00
4	UNIVERSAL MOUNT WITH TILT / SWIVEL	2	\$ 140.00	\$ 280.00
TOTAL BID				\$ 18,063.50

All items are to be shipped FOB Destination. Vendor shall be required to submit a Bill of Lading for all material and items shipped that clearly show actual shipping costs.

THE QUANTITIES LISTED ABOVE ARE FOR BID EVALUATION PURPOSES ONLY. ACTUAL QUANTITIES MAY DIFFER

MANUFACTURER SHEET - TELEVISIONS

PIPESTEM RESORT STATE PARK

Item No.	Description	Manufacturer
1	32" LCD TELEVISION	LG 32LK330

MANUFACTURER SHEET - TELEVISIONS
BLACKWATER FALLS STATE PARK

Item No.	Description	Manufacturer
1	42" LCD TELEVISION	Panasonic TH42LRU30
2	UNIVERSAL MOUNT WITH TILT	New Model Omni-mount 54FB-T
3	UNIVERSAL MOUNT WITH TILT / SWIVEL	Omni-mount UCL-L

MANUFACTURER SHEET - TELEVISIONS

TYGART LAKE STATE PARK

Item No.	Description	Manufacturer
1	37" LED TELEVISION	LG37LV3500
2	55" LED TELEVISION	LG55LV5500
3	UNIVERSAL MOUNT WITH TILT	New model Omni mount 54FB-T
4	UNIVERSAL MOUNT WITH TILT / SWIVEL	Omni mount LEDP75

State of West Virginia

VENDOR PREFERENCE CERTIFICATE

Certification and application* is hereby made for Preference in accordance with West Virginia Code, §5A-3-37. (Does not apply to construction contracts). West Virginia Code, §5A-3-37, provides an opportunity for qualifying vendors to request (at the time of bid) preference for their residency status. Such preference is an evaluation method only and will be applied only to the cost bid in accordance with the West Virginia Code. This certificate for application is to be used to request such preference. The Purchasing Division will make the determination of the Resident Vendor Preference, if applicable.

- 1. Application is made for 2.5% resident vendor preference for the reason checked: Bidder is an individual resident vendor and has resided continuously in West Virginia for four (4) years immediately preceding the date of this certification; or, Bidder is a partnership, association or corporation resident vendor and has maintained its headquarters or principal place of business continuously in West Virginia for four (4) years immediately preceding the date of this certification; or 80% of the ownership interest of Bidder is held by another individual, partnership, association or corporation resident vendor who has maintained its headquarters or principal place of business continuously in West Virginia for four (4) years immediately preceding the date of this certification; or, Bidder is a nonresident vendor which has an affiliate or subsidiary which employs a minimum of one hundred state residents and which has maintained its headquarters or principal place of business within West Virginia continuously for the four (4) years immediately preceding the date of this certification; or,
2. Application is made for 2.5% resident vendor preference for the reason checked: Bidder is a resident vendor who certifies that, during the life of the contract, on average at least 75% of the employees working on the project being bid are residents of West Virginia who have resided in the state continuously for the two years immediately preceding submission of this bid; or,
3. Application is made for 2.5% resident vendor preference for the reason checked: Bidder is a nonresident vendor employing a minimum of one hundred state residents or is a nonresident vendor with an affiliate or subsidiary which maintains its headquarters or principal place of business within West Virginia employing a minimum of one hundred state residents who certifies that, during the life of the contract, on average at least 75% of the employees or Bidder's affiliate's or subsidiary's employees are residents of West Virginia who have resided in the state continuously for the two years immediately preceding submission of this bid; or,
4. Application is made for 5% resident vendor preference for the reason checked: Bidder meets either the requirement of both subdivisions (1) and (2) or subdivision (1) and (3) as stated above; or,
5. Application is made for 3.5% resident vendor preference who is a veteran for the reason checked: Bidder is an individual resident vendor who is a veteran of the United States armed forces, the reserves or the National Guard and has resided in West Virginia continuously for the four years immediately preceding the date on which the bid is submitted; or,
6. Application is made for 3.5% resident vendor preference who is a veteran for the reason checked: Bidder is a resident vendor who is a veteran of the United States armed forces, the reserves or the National Guard, if, for purposes of producing or distributing the commodities or completing the project which is the subject of the vendor's bid and continuously over the entire term of the project, on average at least seventy-five percent of the vendor's employees are residents of West Virginia who have resided in the state continuously for the two immediately preceding years.

Bidder understands if the Secretary of Revenue determines that a Bidder receiving preference has failed to continue to meet the requirements for such preference, the Secretary may order the Director of Purchasing to: (a) reject the bid; or (b) assess a penalty against such Bidder in an amount not to exceed 5% of the bid amount and that such penalty will be paid to the contracting agency or deducted from any unpaid balance on the contract or purchase order.

By submission of this certificate, Bidder agrees to disclose any reasonably requested information to the Purchasing Division and authorizes the Department of Revenue to disclose to the Director of Purchasing appropriate information verifying that Bidder has paid the required business taxes, provided that such information does not contain the amounts of taxes paid nor any other information deemed by the Tax Commissioner to be confidential.

Under penalty of law for false swearing (West Virginia Code, §61-5-3), Bidder hereby certifies that this certificate is true and accurate in all respects; and that if a contract is issued to Bidder and if anything contained within this certificate changes during the term of the contract, Bidder will notify the Purchasing Division in writing immediately.

Bidder: _____ Signed: _____

Date: _____ Title: _____

*Check any combination of preference consideration(s) indicated above, which you are entitled to receive.

STATE OF WEST VIRGINIA
Purchasing Division

PURCHASING AFFIDAVIT

West Virginia Code §5A-3-10a states: No contract or renewal of any contract may be awarded by the state or any of its political subdivisions to any vendor or prospective vendor when the vendor or prospective vendor or a related party to the vendor or prospective vendor is a debtor and the debt owed is an amount greater than one thousand dollars in the aggregate.

DEFINITIONS:

"Debt" means any assessment, premium, penalty, fine, tax or other amount of money owed to the state or any of its political subdivisions because of a judgment, fine, permit violation, license assessment, defaulted workers' compensation premium, penalty or other assessment presently delinquent or due and required to be paid to the state or any of its political subdivisions, including any interest or additional penalties accrued thereon.

"Debtor" means any individual, corporation, partnership, association, limited liability company or any other form or business association owing a debt to the state or any of its political subdivisions. "Political subdivision" means any county commission; municipality; county board of education; any instrumentality established by a county or municipality; any separate corporation or instrumentality established by one or more counties or municipalities, as permitted by law; or any public body charged by law with the performance of a government function or whose jurisdiction is coextensive with one or more counties or municipalities. "Related party" means a party, whether an individual, corporation, partnership, association, limited liability company or any other form or business association or other entity whatsoever, related to any vendor by blood, marriage, ownership or contract through which the party has a relationship of ownership or other interest with the vendor so that the party will actually or by effect receive or control a portion of the benefit, profit or other consideration from performance of a vendor contract with the party receiving an amount that meets or exceeds five percent of the total contract amount.

EXCEPTION: The prohibition of this section does not apply where a vendor has contested any tax administered pursuant to chapter eleven of this code, workers' compensation premium, permit fee or environmental fee or assessment and the matter has not become final or where the vendor has entered into a payment plan or agreement and the vendor is not in default of any of the provisions of such plan or agreement.

Under penalty of law for false swearing (*West Virginia Code* §61-5-3), it is hereby certified that the vendor affirms and acknowledges the information in this affidavit and is in compliance with the requirements as stated.

WITNESS THE FOLLOWING SIGNATURE

Vendor's Name: Lee Hartman & Sons, Inc.

Authorized Signature: *[Signature]* Date: 7-13-2011

State of WV

County of Kanawha, to-wit:

Taken, subscribed, and sworn to before me this 13 day of July, 2011.

My Commission expires July 11, 2013

AFFIX SEAL HERE

NOTARY PUBLIC

[Signature]

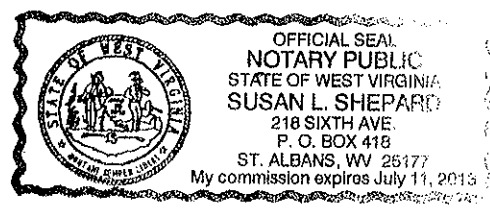

54FB-T product information sheet

Product Specifications

Fits most: 37" - 63" flat panels

Supports up to: 175 lbs (79.4 kg)

Tilt: Up to +15°

Mounting profile: 2.7" (69mm)

Universal & VESA compliant: 100x100 to 400x600

Mounting: Double-stud

UL listed: Yes

Warranty: 5 years

Color: Black

Product Benefits

- Tilt up to +15° to reduce glare
- Universal rails for greater panel compatibility
- Lift n' Lock™ for quick installation
- Tension adjustment for variable tilt
- Sliding lateral on-wall adjustment
- Open architecture for easy trim out
- Locking bar secures panel to mount
- Includes complete Grade 5 hardware kit

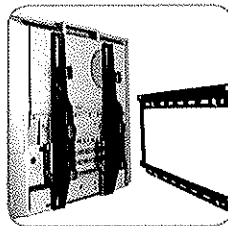
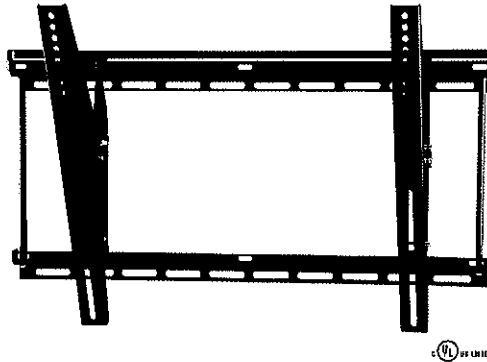

Keeping ease of installation in mind, the 54FB-T was designed to be installed in a few simple steps

Series

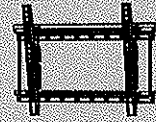

37FB-T

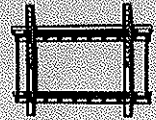

37FB-F

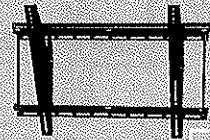

54FB-T

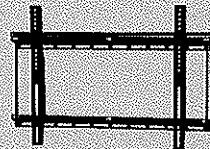

54FB-F

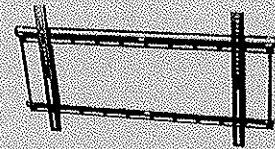

63FB-F

Dedicated to being a one-stop shop for professional products, OmniMount remains on the cutting edge of product innovation. That's why we're the natural choice for any professional, industrial or commercial application. The Fastback Series offers both fixed and tilt universal mounting solutions that are designed for quick and easy installs. The 54FB-T is ideal for budget-conscious customers or high-volume jobs requiring a dependable large tilt mount.

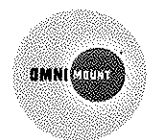

54FB-T line drawing

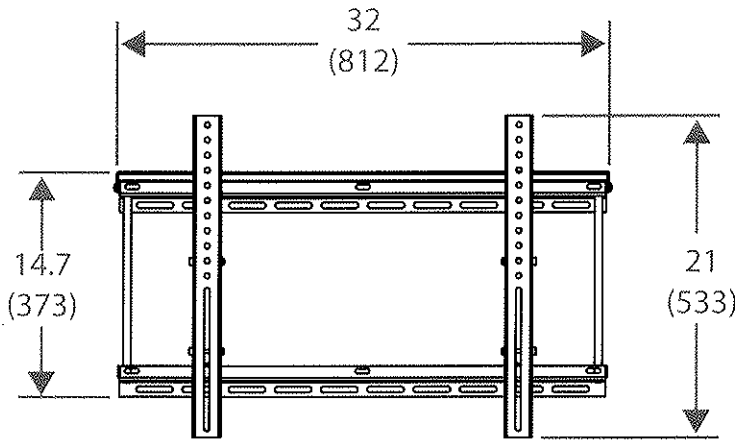
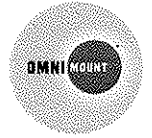

FRONT VIEW

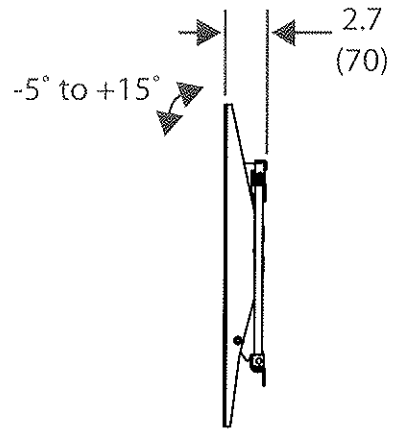

MOUNTING PROFILE

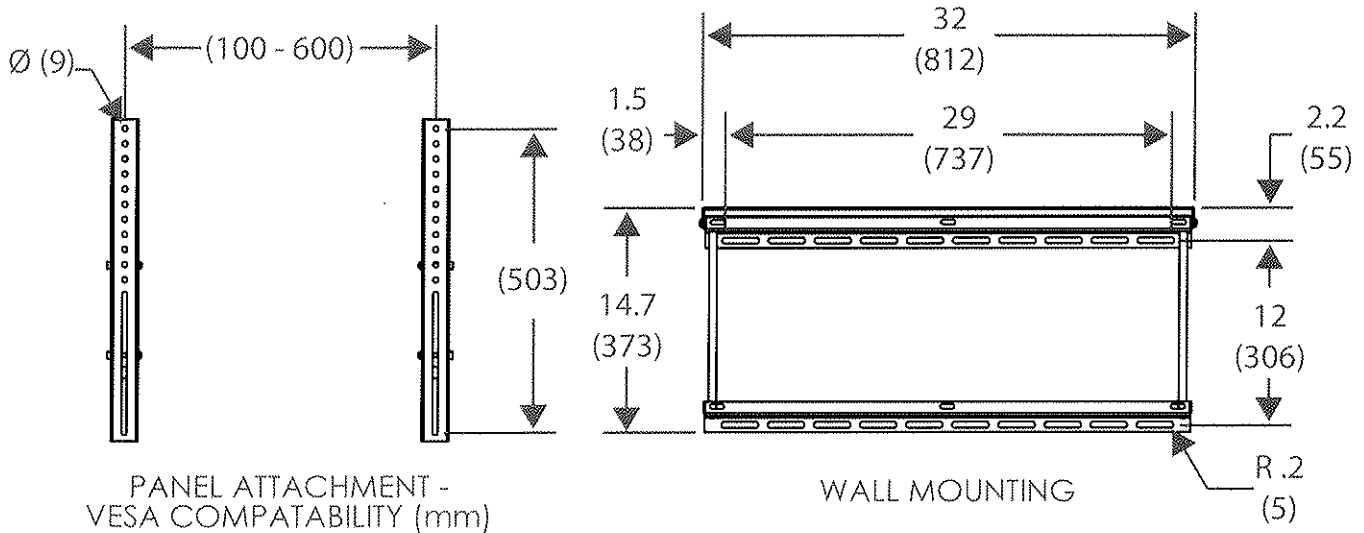

PANEL ATTACHMENT - VESA COMPATIBILITY (mm)

WALL MOUNTING



inches (mm)

Architects Specifications

The flat panel wall mount shall be an OmniMount model 54FB-T and shall be located where indicated on the plans. It shall be constructed of sheet metal with +15° adjustable forward tilt. Assembly and installation shall be done according to instructions provided by the manufacturer.