



State of West Virginia  
 Department of Administration  
 Purchasing Division  
 2019 Washington Street East  
 Post Office Box 50130  
 Charleston, WV 25305-0130

**Request for  
 Quotation**

RFQ NUMBER  
 DEP15573

PAGE  
 1

ADDRESS CORRESPONDENCE TO ATTENTION OF:  
 CHUCK BOWMAN  
 304-558-2157

VENDOR

RFQ COPY  
 TYPE NAME/ADDRESS HERE

**MAIN STREET BUILDERS, LLC**  
 PO Box 309 311 S. Walker Street  
 Princeton, WV 24740  
 WV#035914  
 VA# 2705133610A  
 ph: 304-487-3912 Fax:304-425-2171

SHIP TO

ENVIRONMENTAL PROTECTION  
 DEPT. OF  
 OFFICE OF SPECIAL RECLAMATION  
 116 INDUSTRIAL DRIVE  
 OAK HILL, WV  
 25901 304-465-1911

DATE PRINTED	TERMS OF SALE	SHIP VIA	F.O.B.	FREIGHT TERMS
09/01/2011				

BID OPENING DATE: 09/22/2011 BID OPENING TIME 01:30PM

LINE	QUANTITY	UOP	CAT. NO.	ITEM NUMBER	UNIT PRICE	AMOUNT
0001	1	JB		962-73		\$194,763.00
<p>RECLAMATION: RESTORATION OF LAND</p> <p>THE WEST VIRGINIA PURCHASING DIVISION, FOR THE AGENCY, THE WEST VIRGINIA DEPARTMENT OF ENVIRONMENTAL PROTECTION'S OFFICE OF SPECIAL RECLAMATION, IS REQUESTING BIDS FROM QUALIFIED CONTRACTORS TO PROVIDE ALL LABOR AND MATERIALS TO PERFORM RECLAMATION ON THE MINING OPERATION OF ROYAL SCOT MINERALS, INC., NOW UNDER REVOKED PERMIT NUMBER(S) 31-72. THIS SITE CONSISTS OF APPROXIMATELY 6 ACRES AND IS LOCATED NEAR ANJEAN, WV IN GREENBRIER COUNTY.</p> <p>THE RECLAMATION SHALL BE PERFORMED UNDER THE GUIDANCE AND GENERAL SUPERVISION OF THE AGENT ASSIGNED TO THE PROJECT FOR THE STATE OF WEST VIRGINIA, DEPARTMENT OF ENVIRONMENTAL PROTECTION.</p> <p>A MANDATORY ON-SITE PREBID CONFERENCE SHALL BE HELD ON 09/14/2011 @ 10:00 AM. ALL INTERESTED PARTIES ARE REQUIRED TO ATTEND THIS MEETING. FAILURE TO ATTEND THE MANDATORY PRE-BID SHALL RESULT IN DISQUALIFICATION OF THE BID. NO ONE PERSON MAY REPRESENT MORE THAN ONE BIDDER.</p> <p>AN ATTENDANCE SHEET WILL BE MADE AVAILABLE FOR ALL POTENTIAL BIDDERS TO COMPLETE. THIS WILL SERVE AS THE OFFICIAL DOCUMENT VERIFYING ATTENDANCE AT THE MANDATORY PRE-BID. FAILURE TO PROVIDE YOUR COMPANY AND REPRESENTATIVE NAME ON THE ATTENDANCE SHEET WILL RESULT IN DISQUALIFICATION OF THE BID. THE STATE WILL NOT ACCEPT ANY OTHER DOCUMENTATION TO VERIFY ATTENDANCE. THE BIDDER IS RESPONSIBLE FOR ENSURING THEY HAVE COMPLETED THE INFOR</p>						

RECEIVED  
 2011 SEP 22 PM 12:08  
 WV PURCHASING  
 DIVISION

SEE REVERSE SIDE FOR TERMS AND CONDITIONS

SIGNATURE <i>F. Cole Garner</i>	TELEPHONE 304-487-3912	DATE 9-22-11
TITLE Member	FEN 58-2667955	ADDRESS CHANGES TO BE NOTED ABOVE

WHEN RESPONDING TO RFQ, INSERT NAME AND ADDRESS IN SPACE ABOVE LABELED 'VENDOR'

## GENERAL TERMS & CONDITIONS REQUEST FOR QUOTATION (RFQ) AND REQUEST FOR PROPOSAL (RFP)

1. Awards will be made in the best interest of the State of West Virginia.
2. The State may accept or reject in part, or in whole, any bid.
3. Prior to any award, the apparent successful vendor must be properly registered with the Purchasing Division and have paid the required \$125 fee.
4. All services performed or goods delivered under State Purchase Order/Contracts are to be continued for the term of the Purchase Order/Contracts, contingent upon funds being appropriated by the Legislature or otherwise being made available. In the event funds are not appropriated or otherwise available for these services or goods this Purchase Order/Contract becomes void and of no effect after June 30.
5. Payment may only be made after the delivery and acceptance of goods or services.
6. Interest may be paid for late payment in accordance with the *West Virginia Code*.
7. Vendor preference will be granted upon written request in accordance with the *West Virginia Code*.
8. The State of West Virginia is exempt from federal and state taxes and will not pay or reimburse such taxes.
9. The Director of Purchasing may cancel any Purchase Order/Contract upon 30 days written notice to the seller.
10. The laws of the State of West Virginia and the *Legislative Rules* of the Purchasing Division shall govern the purchasing process.
11. Any reference to automatic renewal is hereby deleted. The Contract may be renewed only upon mutual written agreement of the parties.
12. **BANKRUPTCY:** In the event the vendor/contractor files for bankruptcy protection, the State may deem this contract null and void, and terminate such contract without further order.
13. **HIPAA BUSINESS ASSOCIATE ADDENDUM:** The West Virginia State Government HIPAA Business Associate Addendum (BAA), approved by the Attorney General, is available online at [www.state.wv.us/admin/purchase/vrc/hipaa.htm](http://www.state.wv.us/admin/purchase/vrc/hipaa.htm) and is hereby made part of the agreement. Provided that the Agency meets the definition of a Cover Entity (45 CFR §160.103) and will be disclosing Protected Health Information (45 CFR §160.103) to the vendor.
14. **CONFIDENTIALITY:** The vendor agrees that he or she will not disclose to anyone, directly or indirectly, any such personally identifiable information or other confidential information gained from the agency, unless the individual who is the subject of the information consents to the disclosure in writing or the disclosure is made pursuant to the agency's policies, procedures, and rules. Vendor further agrees to comply with the Confidentiality Policies and Information Security Accountability Requirements, set forth in <http://www.state.wv.us/admin/purchase/privacy/noticeConfidentiality.pdf>.
15. **LICENSING:** Vendors must be licensed and in good standing in accordance with any and all state and local laws and requirements by any state or local agency of West Virginia, including, but not limited to, the West Virginia Secretary of State's Office, the West Virginia Tax Department, and the West Virginia Insurance Commission. The vendor must provide all necessary releases to obtain information to enable the director or spending unit to verify that the vendor is licensed and in good standing with the above entities.
16. **ANTITRUST:** In submitting a bid to any agency for the State of West Virginia, the bidder offers and agrees that if the bid is accepted the bidder will convey, sell, assign or transfer to the State of West Virginia all rights, title and interest in and to all causes of action it may now or hereafter acquire under the antitrust laws of the United States and the State of West Virginia for price fixing and/or unreasonable restraints of trade relating to the particular commodities or services purchased or acquired by the State of West Virginia. Such assignment shall be made and become effective at the time the purchasing agency tenders the initial payment to the bidder.

I certify that this bid is made without prior understanding, agreement, or connection with any corporation, firm, limited liability company, partnership, or person or entity submitting a bid for the same material, supplies, equipment or services and is in all respects fair and without collusion or fraud. I further certify that I am authorized to sign the certification on behalf of the bidder or this bid.

### INSTRUCTIONS TO BIDDERS

1. Use the quotation forms provided by the Purchasing Division. Complete all sections of the quotation form.
2. Items offered must be in compliance with the specifications. Any deviation from the specifications must be clearly indicated by the bidder. Alternates offered by the bidder as EQUAL to the specifications must be clearly defined. A bidder offering an alternate should attach complete specifications and literature to the bid. The Purchasing Division may waive minor deviations to specifications.
3. Unit prices shall prevail in case of discrepancy. All quotations are considered F.O.B. destination unless alternate shipping terms are clearly identified in the quotation.
4. All quotations must be delivered by the bidder to the office listed below prior to the date and time of the bid opening. Failure of the bidder to deliver the quotations on time will result in bid disqualifications: Department of Administration, Purchasing Division, 2019 Washington Street East, P.O. Box 50130, Charleston, WV 25305-0130
5. Communication during the solicitation, bid, evaluation or award periods, except through the Purchasing Division, is strictly prohibited (W.Va. C.S.R. §148-1-6.6).



State of West Virginia  
 Department of Administration  
 Purchasing Division  
 2019 Washington Street East  
 Post Office Box 50130  
 Charleston, WV 25305-0130

# Request for Quotation

BFO NUMBER  
 DEP15573

PAGE  
 2

ADDRESS CORRESPONDENCE TO ATTENTION OF:  
 CHUCK BOWMAN  
 304-558-2157

RFQ COPY  
 TYPE NAME/ADDRESS HERE  
**VENDOR**  
**MAIN STREET BUILDERS, LLC**  
 PO Box 309 311 S. Walker Street  
 Princeton, WV 24740  
 WV#035914  
 VA# 2705133610A  
 ph: 304-487-3912 Fax:304-425-2171

**SHIP TO**  
 ENVIRONMENTAL PROTECTION  
 DEPT. OF  
 OFFICE OF SPECIAL RECLAMATION  
 116 INDUSTRIAL DRIVE  
 OAK HILL, WV  
 25901 304-465-1911

DATE PRINTED	TERMS OF SALE	SHIP VIA	F.O.B.	FREIGHT TERMS
09/01/2011				

BID OPENING DATE: 09/22/2011 BID OPENING TIME 01:30PM

LINE	QUANTITY	UOP	CAT. NO.	ITEM NUMBER	UNIT PRICE	AMOUNT
<p>MATION REQUIRED ON THE ATTENDANCE SHEET. THE PURCHASING DIVISION AND THE STATE AGENCY WILL NOT ASSUME ANY RESPONSIBILITY FOR A BIDDER'S FAILURE TO COMPLETE THE PRE-BID ATTENDANCE SHEET. IN ADDITION, WE REQUEST THAT ALL POTENTIAL BIDDERS INCLUDE THEIR E-MAIL ADDRESS AND FAX NUMBER.</p> <p>ALL POTENTIAL BIDDERS ARE REQUESTED TO ARRIVE PRIOR TO THE STARTING TIME FOR THE PRE-BID. BIDDERS WHO ARRIVE LATE, BUT PRIOR TO THE DISMISSAL OF THE TECHNICAL PORTION OF THE PRE-BID WILL BE PERMITTED TO SIGN IN. BIDDERS WHO ARRIVE AFTER CONCLUSION OF THE TECHNICAL PORTION OF THE PRE-BID, BUT DURING ANY SUBSEQUENT PART OF THE PRE-BID WILL NOT BE PERMITTED TO SIGN THE ATTENDANCE SHEET.</p> <p>DIRECTIONS TO PRE-BID: FROM THE RUPERT POST OFFICE, TRAVEL EAST ON U.S. RT. 60 APPROXIMATELY 100 FEET AND TURN LEFT ON TO COUNTY RT. 1 (ANJEAN ROAD). TRAVEL APPROXIMATELY 5.8 MILES AND TURN RIGHT AT THE TRUCK SCALES. CROSS BRIDGE AND TURN RIGHT. TRAVEL APPROXIMATELY 2.7 MILES TO INTERSECTION AND TURN RIGHT THROUGH GATE AND TRAVEL APPROXIMATELY 0.6 MILE TO THE MINE SITE.</p> <p>ALL WORK MUST BE COMPLETED IN ACCORDANCE WITH THE PLANS AND SPECIFICATIONS PREPARED BY THE DEPARTMENT OF ENVIRONMENTAL PROTECTION AND PURCHASE ORDER ISSUED BY THE DEPARTMENT OF ADMINISTRATION, DIVISION OF PURCHASING.</p> <p>EXHIBIT 5</p> <p>WEST VIRGINIA CODE 21-1D-5 PROVIDES THAT: ANY SOLICITATION FOR A PUBLIC IMPROVEMENT CONSTRUCTION CONTRACT REQUIRES EACH VENDOR THAT SUBMITS A BID FOR THE WORK TO SUBMIT AT THE SAME TIME AN AFFIDAVIT OF COMPLIANCE WITH THE BID. THE ENCLOSED PURCHASING AFFIDAVIT MUST BE</p>						

SEE REVERSE SIDE FOR TERMS AND CONDITIONS

SIGNATURE <i>J. John Garner</i>	TELEPHONE 304-487-3912	DATE 9-22-11
TITLE Member	FEIN 58-2667955	ADDRESS CHANGES TO BE NOTED ABOVE

WHEN RESPONDING TO RFQ, INSERT NAME AND ADDRESS IN SPACE ABOVE LABELED 'VENDOR'



State of West Virginia  
 Department of Administration  
 Purchasing Division  
 2019 Washington Street East  
 Post Office Box 50130  
 Charleston, WV 25305-0130

# Request for Quotation

RFQ NUMBER  
 DEP15573

PAGE  
 3

ADDRESS CORRESPONDENCE TO ATTENTION OF:  
 CHUCK BOWMAN  
 304-558-2157

RFQ COPY  
 TYPE NAME/ADDRESS HERE

VENDOR

**MAIN STREET BUILDERS, LLC**  
 PO Box 309 311 S. Walker Street  
 Princeton, WV 24740  
 WV#035914  
 VA# 2705133610A  
 ph: 304-487-3912 Fax:304-425-2171

SHIP TO

ENVIRONMENTAL PROTECTION  
 DEPT. OF  
 OFFICE OF SPECIAL RECLAMATION  
 116 INDUSTRIAL DRIVE  
 OAK HILL, WV  
 25901 304-465-1911

DATE PRINTED	TERMS OF SALE	SHIP VIA	F.O.B.	FREIGHT TERMS
09/01/2011				

BID OPENING DATE: 09/22/2011 BID OPENING TIME 01:30PM

LINE	QUANTITY	UOP	CAT. NO.	ITEM NUMBER	UNIT PRICE	AMOUNT
<p>SIGNED AND SUBMITTED WITH THE BID AS EVIDENCE OF THE VENDOR'S COMPLIANCE WITH THE PROVISIONS OF ARTICLE 1D, CHAPTER 21 OF THE WEST VIRGINIA CODE. FAILURE TO SUBMIT THE SIGNED PURCHASING AFFIDAVIT WITH THE BID SHALL RESULT IN DISQUALIFICATION OF SUCH BID.</p> <p>NOTICE TO PROCEED: THIS CONTRACT IS TO BE PERFORMED WITH 365 CALENDAR DAYS AFTER THE NOTICE TO PROCEED IS RECEIVED. UNLESS OTHERWISE SPECIFIED, THE FULLY EXECUTED PURCHASE ORDER WILL BE CONSIDERED NOTICE TO PROCEED.</p> <p>CANCELLATION: THE DIRECTOR OF PURCHASING RESERVES THE RIGHT TO CANCEL THIS CONTRACT IMMEDIATELY UPON WRITTEN NOTICE TO THE VENDOR IF THE MATERIALS OR WORKMANSHIP SUPPLIED ARE OF AN INFERIOR QUALITY OR DO NOT CONFORM WITH THE SPECIFICATIONS OF THE THE BID AND CONTRACT HERE IN.</p> <p>WAGE RATES: THE CONTRACTOR OR SUBCONTRACTOR SHALL PAY THE HIGHER OF THE U.S. DEPARTMENT OF LABOR MINIMUM WAGE RATES AS ESTABLISHED FOR GREENBRIER COUNTY, PURSUANT TO WEST VIRGINIA CODE 21-5A, ET, SEQ. (PREVAILING WAGE RATES APPLY TO THIS PROJECT)</p> <p>ARBITRATION: ANY REFERENCES MADE TO ARBITRATION OR INTEREST FOR PAYMENTS DUE (EXCEPT FOR ANY INTEREST REQUIRED BY STATE LAW) CONTAINED IN THIS CONTRACT OR IN ANY AMERICAN INSTITUTE OF ARCHITECTS DOCUMENTS PERTAINING TO THIS CONTRACT ARE HEREBY DELETED.</p> <p>WORKERS' COMPENSATION: VENDOR IS REQUIRED TO PROVIDE A CERTIFICATE FROM WORKERS' COMPENSATION IF SUCCESSFUL.</p> <p>ALL OF THE ITEMS CHECKED BELOW WILL BE A REQUIREMENT OF THIS CONTRACT:</p>						

SEE REVERSE SIDE FOR TERMS AND CONDITIONS

SIGNATURE <i>A. Blumberg</i>	TELEPHONE 304-487-3912	DATE 9-22-11
TITLE Member	FEIN 58-2667955	ADDRESS CHANGES TO BE NOTED ABOVE

WHEN RESPONDING TO RFQ, INSERT NAME AND ADDRESS IN SPACE ABOVE LABELED 'VENDOR'



State of West Virginia  
 Department of Administration  
 Purchasing Division  
 2019 Washington Street East  
 Post Office Box 50130  
 Charleston, WV 25305-0130

# Request for Quotation

RFQ NUMBER  
 DEP15573

PAGE  
 4

ADDRESS CORRESPONDENCE TO ATTENTION OF:  
 CHUCK BOWMAN  
 304-558-2157

RFQ COPY  
 TYPE NAME/ADDRESS HERE

**VENDOR**

**MAIN STREET BUILDERS, LLC**  
 PO Box 309 311 S. Walker Street  
 Princeton, WV 24740  
 WV#035914  
 VA# 2705133610A  
 ph: 304-487-3912 Fax:304-425-2171

**SHIP TO**

ENVIRONMENTAL PROTECTION  
 DEPT. OF  
 OFFICE OF SPECIAL RECLAMATION  
 116 INDUSTRIAL DRIVE  
 OAK HILL, WV  
 25901 304-465-1911

DATE PRINTED	TERMS OF SALE	SHIP VIA	F.O.B.	FREIGHT TERMS
09/01/2011				

BID OPENING DATE: 09/22/2011 BID OPENING TIME 01:30PM

LINE	QUANTITY	UOP	CAT. NO.	ITEM NUMBER	UNIT PRICE	AMOUNT
<p>(XX) INSURANCE: SUCCESSFUL VENDOR SHALL FURNISH PROOF OF COMMERCIAL GENERAL LIABILITY INSURANCE PRIOR TO ISSUANCE OF CONTRACT. UNLESS OTHERWISE SPECIFIED IN THE BID DOCUMENTS, THE MINIMUM AMOUNT OF INSURANCE COVERAGE REQUIRED IS \$250,000.</p> <p>( ) BUILDERS RISK INSURANCE: SUCCESSFUL VENDOR SHALL FURNISH PROOF OF BUILDERS RISK - ALL RISK INSURANCE IN AN AMOUNT EQUAL TO 100% OF THE AMOUNT OF THE CONTRACT.</p> <p>(XX) BONDS: FIVE PERCENT (5%) OF THE TOTAL AMOUNT OF THE BID PAYABLE TO THE STATE OF WEST VIRGINIA, SHALL BE SUBMITTED WITH EACH BID AS A BID BOND. THE SUCCESSFUL BIDDER SHALL ALSO FURNISH A PERFORMANCE BOND AND LABOR/MATERIAL BOND FOR 100% OF THE AMOUNT OF THE CONTRACT. BONDS MAY BE PROVIDED IN THE FORM OF A CERTIFIED CHECK, IRREVOCABLE LETTER OF CREDIT, OR BOND FURNISHED BY A SOLVENT SURETY COMPANY AUTHORIZED TO DO BUSINESS IN THE STATE OF WEST VIRGINIA. A LETTER OF CREDIT SUBMITTED IN LIEU OF A BOND WILL ONLY BE ALLOWED FOR PROJECTS UNDER \$100,000. PERSONAL OR BUSINESS CHECKS ARE NOT ACCEPTABLE IN LIEU OF THE 5% BID BOND, PERFORMANCE BOND, OR LABOR AND MATERIAL BOND.</p> <p>( ) MAINTENANCE BOND: A TWO (2) YEAR MAINTENANCE BOND COVERING THE ROOFING SYSTEM WILL BE A REQUIREMENT OF THE SUCCESSFUL VENDOR.</p> <p>REV. 11/00</p> <p>CONTRACTORS LICENSE</p> <p>WEST VIRGINIA STATE CODE 21-11-2 REQUIRES THAT ALL PERSONS DESIRING TO PERFORM CONTRACTING WORK IN THIS STATE MUST BE LICENSED. THE WEST VIRGINIA CONTRACTORS LICENSING BOARD IS EMPOWERED TO ISSUE THE CONTRACTORS</p>						

SEE REVERSE SIDE FOR TERMS AND CONDITIONS

SIGNATURE: *F. John Garner* TELEPHONE: 304-487-3912 DATE: 9-22-11

TITLE: Member FEIN: 58-2667955 ADDRESS CHANGES TO BE NOTED ABOVE

WHEN RESPONDING TO RFQ, INSERT NAME AND ADDRESS IN SPACE ABOVE LABELED 'VENDOR'



State of West Virginia  
 Department of Administration  
 Purchasing Division  
 2019 Washington Street East  
 Post Office Box 50130  
 Charleston, WV 25305-0130

# Request for Quotation

RFQ NUMBER  
 DEP15573

PAGE  
 5

ADDRESS CORRESPONDENCE TO ATTENTION OF  
 CHUCK BOWMAN  
 304-558-2157

RFQ COPY

TYPE NAME/ADDRESS HERE

VENDOR

**MAIN STREET BUILDERS, LLC**  
 PO Box 309 311 S. Walker Street  
 Princeton, WV 24740  
 WV#035914  
 VA# 2705133610A  
 ph: 304-487-3912 Fax:304-425-2171

SHIP TO

ENVIRONMENTAL PROTECTION  
 DEPT. OF  
 OFFICE OF SPECIAL RECLAMATION  
 116 INDUSTRIAL DRIVE  
 OAK HILL, WV  
 25901 304-465-1911

DATE PRINTED	TERMS OF SALE	SHIP VIA	F.O.B.	FREIGHT TERMS
09/01/2011				

BID OPENING DATE: 09/22/2011 BID OPENING TIME 01:30PM

LINE	QUANTITY	UOP	CAT. NO.	ITEM NUMBER	UNIT PRICE	AMOUNT
<p>LICENSE. APPLICATIONS FOR A CONTRACTORS LICENSE MAY BE MADE BY CONTACTING THE WEST VIRGINIA DIVISION OF LABOR (CAPITOL COMPLEX, BUILDING 3, ROOM 319, CHARLESTON, WV 25305. TELEPHONE: (304) 558-7890.</p> <p>WEST VIRGINIA STATE CODE 21-11-11 REQUIRES ANY PROSPECTIVE BIDDER TO INCLUDE THE CONTRACTORS LICENSE NUMBER ON THEIR BID.</p> <p>BIDDER TO COMPLETE: MAIN STREET BUILDERS, LLC            CONTRACTORS NAME: ...            CONTRACTORS LICENSE NO.: WV# 035914</p> <p>THE SUCCESSFUL BIDDER WILL BE REQUIRED TO FURNISH A COPY OF THEIR CONTRACTORS LICENSE PRIOR TO ISSUANCE OF A PURCHASE ORDER/CONTRACT.</p> <p>APPLICABLE LAW</p> <p>THE WEST VIRGINIA STATE CODE, PURCHASING DIVISION RULES AND REGULATIONS, AND THE INFORMATION PROVIDED IN THE "REQUEST FOR QUOTATION" ISSUED BY THE PURCHASING DIVISION IS THE SOLE AUTHORITY GOVERNING THIS PROCUREMENT.</p> <p>ANY INFORMATION PROVIDED IN SPECIFICATION MANUALS, OR ANY OTHER SOURCE, VERBAL OR WRITTEN, WHICH CONTRADICTS OR ALTERS THE INFORMATION PROVIDED FROM THE SOURCES AS DESCRIBED IN THE ABOVE PARAGRAPH IS VOID AND OF NO EFFECT.</p> <p>BANKRUPTCY: IN THE EVENT THE VENDOR/CONTRACTOR FILES FOR BANKRUPTCY PROTECTION, THE STATE MAY DEEM THIS CONTRACT NULL AND VOID AND TERMINATE SUCH CONTRACT WITHOUT FURTHER ORDER.</p>						

SEE REVERSE SIDE FOR TERMS AND CONDITIONS

SIGNATURE <i>F. John Gann</i>	TELEPHONE 304-487-3912	DATE 9-22-11
TITLE Member	FEIN 58-2667955	ADDRESS CHANGES TO BE NOTED ABOVE

WHEN RESPONDING TO RFQ, INSERT NAME AND ADDRESS IN SPACE ABOVE LABELED 'VENDOR'



State of West Virginia  
 Department of Administration  
 Purchasing Division  
 2019 Washington Street East  
 Post Office Box 50130  
 Charleston, WV 25305-0130

# Request for Quotation

RFQ NUMBER  
 DEP15573

PAGE  
 6

ADDRESS CORRESPONDENCE TO ATTENTION OF:  
 CHUCK BOWMAN  
 304-558-2157

RFQ COPY  
 TYPE NAME/ADDRESS HERE

VENDOR

**MAIN STREET BUILDERS, LLC**  
 PO Box 309 311 S. Walker Street  
 Princeton, WV 24740  
 WV#035914  
 VA# 2705133610A  
 ph: 304-487-3912 Fax:304-425-2171

SHIP TO

ENVIRONMENTAL PROTECTION  
 DEPT. OF  
 OFFICE OF SPECIAL RECLAMATION  
 116 INDUSTRIAL DRIVE  
 OAK HILL, WV  
 25901 304-465-1911

DATE PRINTED	TERMS OF SALE	SHIP VIA	F.O.B.	FREIGHT TERMS
09/01/2011				

BID OPENING DATE: 09/22/2011 BID OPENING TIME 01:30PM

LINE	QUANTITY	UOP	CAT. NO.	ITEM NUMBER	UNIT PRICE	AMOUNT
PREFERENCE FOR USE OF DOMESTIC STEEL PRODUCTS						
1.	EXCEPT WHEN AUTHORIZED BY THE DIRECTOR OF THE PURCHASING DIVISION PURSUANT TO SUBSECTION 2 BELOW, NO CONTRACTOR MAY USE OR SUPPLY STEEL PRODUCTS FOR A STATE CONTRACT PROJECT OTHER THAN THOSE STEEL PRODUCTS MADE IN THE UNITED STATES. AS USED IN THIS CONTRACT,					
	A. "STATE CONTRACT PROJECT" MEANS ANY ERECTION OR CONSTRUCTION OF, OR ANY ADDITION TO, ALTERATIO OF OR OTHER IMPROVEMENT TO ANY BUILDING OR STRUCTURE, INCLUDING, BUT NOT LIMITED TO, ROADS OR HIGHWAYS, OR THE INSTALLATION OF ANY HEATING OR COOLING OR VENTILATING PLANTS OR OTHER EQUIPMENT, OR THE SUPPLY OF AND MATERIALS FOR SUCH PROJECTS, PURSUANT TO A CONTRACT WITH THE STATE OF WEST VIRGINIA FOR WHICH BIDS WERE SOLICITED ON OR AFTER JUNE 6, 2001.					
	B. "STEEL PRODUCTS" MEANS PRODUCTS ROLLED, FORMED, SHAPED, DRAWN, EXTRUDED, FORGED, CAST, FABRICATED OR OTHERWISE SIMILARLY PROCESSED, O PROCESSED BY A COMBINATION OF TWO OR MORE OF SUCH OPERATIONS, FROM STEEL MADE BY THE OPEN HEARTH, BASIC OXYGEN, ELECTRIC FURNACE, BESSEMER OR OTHER STEEL MAKING PROCESS.					
	C. "UNITED STATES" MEANS THE UNITED STATES OF AMERICA AND INCLUDES ALL TERRITORY, CONTINENTAL OR INSULAR, SUBJECT TO THE JURISDICTION OF THE UNITED STATES.					
2.	THE DIRECTOR OF THE PURCHASING DIVISION MAY, IN WRITING, AUTHORIZE THE USE OF FOREIGN STEEL					

SEE REVERSE SIDE FOR TERMS AND CONDITIONS

SIGNATURE <i>John Garner</i>	TELEPHONE 304-487-3912	DATE 9-22-11
TITLE Member	FEIN 58-2667955	ADDRESS CHANGES TO BE NOTED ABOVE

WHEN RESPONDING TO RFQ, INSERT NAME AND ADDRESS IN SPACE ABOVE LABELED 'VENDOR'



State of West Virginia  
 Department of Administration  
 Purchasing Division  
 2019 Washington Street East  
 Post Office Box 50130  
 Charleston, WV 25305-0130

# Request for Quotation

RFQ NUMBER  
 DEP15573

PAGE  
 7

ADDRESS CORRESPONDENCE TO ATTENTION OF  
 CHUCK BOWMAN  
 304-558-2157

RFQ COPY

TYPE NAME/ADDRESS HERE

VENDOR

**MAIN STREET BUILDERS, LLC**  
 PO Box 309 311 S. Walker Street  
 Princeton, WV 24740  
 WV#035914  
 VA# 2705133610A  
 ph: 304-487-3912 Fax:304-425-2171

SHIP TO

ENVIRONMENTAL PROTECTION  
 DEPT. OF  
 OFFICE OF SPECIAL RECLAMATION  
 116 INDUSTRIAL DRIVE  
 OAK HILL, WV  
 25901 304-465-1911

DATE PRINTED	TERMS OF SALE	SHIP VIA	F.O.B.	FREIGHT TERMS
09/01/2011				

BID OPENING DATE: 09/22/2011 BID OPENING TIME 01:30PM

LINE	QUANTITY	UOP	CAT. NO.	ITEM NUMBER	UNIT PRICE	AMOUNT
<p>PRODUCTS IF:</p> <p>A. THE COST FOR EACH CONTRACT ITEM USED DOES NOT EXCEED ONE TENTH OF ONE PERCENT (.1%) OF THE TOTAL CONTRACT COST OR TWO THOUSAND FIVE HUNDRED DOLLARS (2,500.00), WHICHEVER IS GREATER. FOR THE PURPOSES OF THIS SECTION, THE COST IS THE VALUE OF THE STEEL PRODUCT AS DELIVERED TO THE PROJECT OR,</p> <p>B. THE DIRECTOR OF THE PURCHASING DIVISION DETERMINES THAT SPECIFIED STEEL MATERIALS ARE NOT PRODUCED IN THE UNITED STATES IN SUFFICIENT QUANTITY OR OTHERWISE ARE NOT REASONABLY AVAILABLE TO MEET CONTRACT REQUIREMENTS.</p> <p>3. A CONTRACTOR WHO USES STEEL PRODUCTS IN VIOLATION OF THIS SECTION MAY BE SUBJECT TO CIVIL PENALTIES PURSUANT TO WV CODE SECTION 5A-3-56.</p> <p>REV. 10/01/01</p> <p>EXHIBIT 7</p> <p>DOMESTIC ALUMINUM, GLASS &amp; STEEL IN PUBLIC WORKS PROJECTS</p> <p>IN ACCORDANCE WITH WEST VIRGINIA CODE 5-19-1 ET., SEQ., EVERY CONTRACT FOR CONSTRUCTION, RECONSTRUCTION, ALTERATION, REPAIR, IMPROVEMENT OR MAINTENANCE OF PUBLIC WORKS, WHERE THE COST IS MORE THAN \$50,000 AND, IN THE CASE OF STEEL ONLY, WHERE THE COST OF STEEL IS MORE THAN \$50,000 OR WHERE MORE THAN 10,000 POUNDS OF STEEL ARE REQUIRED, THE STATE WILL ACCEPT ONLY ALUMINUM GLASS, OR STEEL PRODUCTS PRODUCED IN THE UNITED STATES</p>						

SEE REVERSE SIDE FOR TERMS AND CONDITIONS

SIGNATURE <i>J. Alan Garner</i>	TELEPHONE 304-487-3912	DATE 9-22-11
TITLE Member	FEIN 58-2667955	ADDRESS CHANGES TO BE NOTED ABOVE

WHEN RESPONDING TO RFQ, INSERT NAME AND ADDRESS IN SPACE ABOVE LABELED 'VENDOR'





State of West Virginia  
 Department of Administration  
 Purchasing Division  
 2019 Washington Street East  
 Post Office Box 50130  
 Charleston, WV 25305-0130

# Request for Quotation

RFQ NUMBER  
 DEP15573

PAGE  
 8

ADDRESS CORRESPONDENCE TO ATTENTION OF:  
 CHUCK BOWMAN  
 304-558-2157

VENDOR

RFQ COPY  
 TYPE NAME/ADDRESS HERE

**MAIN STREET BUILDERS, LLC**  
 PO Box 309 311 S. Walker Street  
 Princeton, WV 24740  
 WV#035914  
 VA# 2705133610A  
 ph: 304-487-3912 Fax:304-425-2171

SHIP TO

ENVIRONMENTAL PROTECTION  
 DEPT. OF  
 OFFICE OF SPECIAL RECLAMATION  
 116 INDUSTRIAL DRIVE  
 OAK HILL, WV  
 25901 304-465-1911

DATE PRINTED	TERMS OF SALE	SHIP VIA	F.O.B.	FREIGHT TERMS
09/01/2011				

BID OPENING DATE: 09/22/2011 BID OPENING TIME 01:30PM

LINE	QUANTITY	UOP	CAT NO.	ITEM NUMBER	UNIT PRICE	AMOUNT
<p>IN ADDITION, ITEMS OF MACHINERY OR EQUIPMENT PURCHASED FOR USE AT THE SITE OF PUBLIC WORKS SHALL BE MADE OF DOMESTIC ALUMINUM, GLASS OR STEEL, UNLESS THE COST OF THE PRODUCT IS LESS THAN \$50,000 OR LESS THAN 10,000 POUNDS OF STEEL ARE USED IN PUBLIC WORKS PROJECTS.</p> <p>FOREIGN MADE ALUMINUM, GLASS OR STEEL PRODUCTS MAY BE ACCEPTED ONLY IF THE COST OF DOMESTIC PRODUCTS IS FOUND TO BE UNREASONABLE. SUCH COST IS UNREASONABLE IF IT IS 20% OR MORE HIGHER THAN THE BID PRICE FOR FOREIGN MADE PRODUCTS. IF THE DOMESTIC ALUMINUM, GLASS OR STEEL PRODUCTS TO BE SUPPLIED OR PRODUCED IN A "SUBSTANTIAL LABOR SURPLUS AREA", AS DEFINED BY THE UNITED STATES DEPARTMENT OF LABOR, FOREIGN PRODUCTS MAY BE SUPPLIED ONLY IF DOMESTIC PRODUCTS ARE 30% OR MORE HIGHER IN PRICE THAN THE FOREIGN MADE PRODUCTS.</p> <p>IF, PRIOR TO THE AWARD OF A CONTRACT UNDER THE ABOVE PROVISIONS, THE SPENDING OFFICER OF THE SPENDING UNIT DETERMINES THAT THERE EXISTS A BID FOR LIKE FOREIGN ALUMINUM, GLASS OR STEEL THAT IS REASONABLE AND LOWER THAN THE LOWEST BID DOMESTIC PRODUCTS, THE SPENDING OFFICE MAY REQUEST, IN WRITING, A REEVALUATION AND REDUCTION IN THE LOWEST BID FOR SUCH DOMESTIC PRODUCTS ALL VENDORS MUST INDICATE IN THEIR BID IF THEY ARE SUPPLYING FOREIGN ALUMINUM, GLASS OR STEEL.</p> <p>REV. 3/88</p> <p>EXHIBIT 9</p> <p>NOTICE FOR ISSUANCE &amp; ACKNOWLEDGEMENT OF CONSTRUCTION PROJECT ADDENDA</p> <p>THE ARCHITECT/ENGINEER AND/OR AGENCY SHALL BE REQUIRED TO ABIDE BY THE FOLLOWING SCHEDULE IN ISSUING</p>						

SEE REVERSE SIDE FOR TERMS AND CONDITIONS

SIGNATURE <i>J. John Garner</i>	TELEPHONE 304-487-3912	DATE 9-22-11
TITLE Member	FEN 58-2667955	ADDRESS CHANGES TO BE NOTED ABOVE

WHEN RESPONDING TO RFQ, INSERT NAME AND ADDRESS IN SPACE ABOVE LABELED 'VENDOR'



State of West Virginia  
 Department of Administration  
 Purchasing Division  
 2019 Washington Street East  
 Post Office Box 50130  
 Charleston, WV 25305-0130

# Request for Quotation

RFQ NUMBER  
 DEP15573

PAGE  
 9

ADDRESS CORRESPONDENCE TO ATTENTION OF:  
 CHUCK BOWMAN  
 304-558-2157

RFQ COPY

TYPE NAME/ADDRESS HERE

V  
E  
N  
D  
O  
R

**MAIN STREET BUILDERS, LLC**  
 PO Box 309 311 S. Walker Street  
 Princeton, WV 24740  
 WV#035914  
 VA# 2705133610A  
 ph: 304-487-3912 Fax:304-425-2171

S  
H  
I  
P  
T  
O

ENVIRONMENTAL PROTECTION  
 DEPT. OF  
 OFFICE OF SPECIAL RECLAMATION  
 116 INDUSTRIAL DRIVE  
 OAK HILL, WV  
 25901 304-465-1911

DATE PRINTED	TERMS OF SALE	SHIP VIA	F.O.B.	FREIGHT TERMS
09/01/2011				

BID OPENING DATE: 09/22/2011 BID OPENING TIME 01:30PM

LINE	QUANTITY	UOP	CAT. NO.	ITEM NUMBER	UNIT PRICE	AMOUNT
<p>CONSTRUCTION PROJECT ADDENDA FOR STATE AGENCIES:</p> <p>(1) THE ARCHITECT/ENGINEER SHALL PREPARE THE ADDENDUM AND A LIST OF ALL PARTIES THAT HAVE PROCURED DRAWINGS AND SPECIFICATIONS FOR THE PROJECT. THE ADDENDUM AND LIST SHALL BE FORWARDED TO THE BUYER IN THE STATE PURCHASING DIVISION. THE ARCHITECT/ENGINEER SHALL ALSO SEND A COPY OF THE ADDENDUM TO THE STATE AGENCY FOR WHICH THE CONTRACT IS ISSUED.</p> <p>(2) THE BUYER SHALL SEND THE ADDENDUM TO ALL INTERESTED PARTIES AND, IF NECESSARY, EXTEND THE BID OPENING DATE. ANY ADDENDUM SHOULD BE RECEIVED BY THE BUYER WITHIN FOURTEEN (14) DAYS PRIOR TO THE BID OPENING DATE.</p> <p>(3) ALL ADDENDA SHOULD BE FORMALLY ACKNOWLEDGED BY ALL BIDDERS AND SUBMITTED TO THE STATE PURCHASING DIVISION. THE SAME RULES AND REGULATIONS THAT APPLY TO THE ORIGINAL BIDDING DOCUMENT SHALL ALSO APPLY TO AN ADDENDUM DOCUMENT. THE ONLY EXCEPTION MAY BE FOR AN ADDENDUM THAT IS ISSUED FOR THE SOLE PURPOSE OF CHANGING A BID OPENING TIME AND/OR DATE.</p> <p>REV. 11/96</p> <p>EXHIBIT 1.0</p> <p>ADDENDUM ACKNOWLEDGEMENT</p> <p>I HEREBY ACKNOWLEDGE RECEIPT OF THE FOLLOWING CHECKED ADDENDUM(S) AND HAVE MADE THE NECESSARY REVISIONS TO MY PROPOSAL, PLANS AND/OR SPECIFICATION, ETC.</p> <p>ADDENDUM NOS.:</p>						
				DEP. 15573		

SEE REVERSE SIDE FOR TERMS AND CONDITIONS

SIGNATURE <i>J. H. Garner</i>	TELEPHONE 304-487-3912	DATE 9-22-11
TITLE <i>Member</i>	FEIN 58-2667955	ADDRESS CHANGES TO BE NOTED ABOVE

WHEN RESPONDING TO RFQ, INSERT NAME AND ADDRESS IN SPACE ABOVE LABELED 'VENDOR'



State of West Virginia  
 Department of Administration  
 Purchasing Division  
 2019 Washington Street East  
 Post Office Box 50130  
 Charleston, WV 25305-0130

# Request for Quotation

RFQ NUMBER  
 DEP15573

PAGE  
 10

ADDRESS CORRESPONDENCE TO ATTENTION OF:  
 CHUCK BOWMAN  
 304-558-2157

VENDOR

RFQ COPY  
 TYPE NAME/ADDRESS HERE

**MAIN STREET BUILDERS, LLC**  
 PO Box 309 311 S. Walker Street  
 Princeton, WV 24740  
 WV#035914  
 VA# 2705133610A  
 ph: 304-487-3912 Fax:304-425-2171

SHIP TO

ENVIRONMENTAL PROTECTION  
 DEPT. OF  
 OFFICE OF SPECIAL RECLAMATION  
 116 INDUSTRIAL DRIVE  
 OAK HILL, WV  
 25901 304-465-1911

DATE PRINTED	TERMS OF SALE	SHIP VIA	F.O.B.	FREIGHT TERMS
09/01/2011				

BID OPENING DATE: 09/22/2011 BID OPENING TIME 01:30PM

LINE	QUANTITY	UOP	CAT. NO.	ITEM NUMBER	UNIT PRICE	AMOUNT
NO. 1		✓	✓	✓		
NO. 2						
NO. 3						
NO. 4						
NO. 5						
<p>I UNDERSTAND THAT FAILURE TO CONFIRM THE RECEIPT OF THE ADDENDUM(S) MAY BE CAUSE FOR REJECTION OF THE BIDS.</p> <p>VENDOR MUST CLEARLY UNDERSTAND THAT ANY VERBAL REPRESENTATION MADE OR ASSUMED TO BE MADE DURING ANY ORAL DISCUSSION HELD BETWEEN VENDOR'S REPRESENTATIVES AND ANY STATE PERSONNEL IS NOT BINDING. ONLY THE INFORMATION ISSUED IN WRITING AND ADDED TO THE SPECIFICATIONS BY AN OFFICIAL ADDENDUM IS BINDING.</p> <p><i>[Signature]</i> .....SIGNATURE            MAIN STREET BUILDERS, LLC .....COMPANY            9-22-11 .....DATE</p> <p>REV. 11/96</p> <p>NOTICE</p> <p>A SIGNED BID MUST BE SUBMITTED TO:            DEPARTMENT OF ADMINISTRATION            PURCHASING DIVISION</p>						

SEE REVERSE SIDE FOR TERMS AND CONDITIONS		
SIGNATURE <i>[Signature]</i>	TELEPHONE 304-487-3912	DATE 9-22-11
TITLE Member	FEIN 58-2667955	ADDRESS CHANGES TO BE NOTED ABOVE

WHEN RESPONDING TO RFQ, INSERT NAME AND ADDRESS IN SPACE ABOVE LABELED 'VENDOR'



State of West Virginia  
 Department of Administration  
 Purchasing Division  
 2019 Washington Street East  
 Post Office Box 50130  
 Charleston, WV 25305-0130

# Request for Quotation

RFQ NUMBER DEP15573
------------------------

PAGE 11
------------

ADDRESS CORRESPONDENCE TO ATTENTION OF: CHUCK BOWMAN 304-558-2157
---

RFQ COPY  
 TYPE NAME/ADDRESS HERE

**MAIN STREET BUILDERS, LLC**  
 PO Box 309 311 S. Walker Street  
 Princeton, WV 24740  
 WV#035914  
 VA# 2705133610A  
 ph: 304-487-3912 Fax:304-425-2171

ENVIRONMENTAL PROTECTION  
 DEPT. OF  
 OFFICE OF SPECIAL RECLAMATION  
 116 INDUSTRIAL DRIVE  
 OAK HILL, WV  
 25901 304-465-1911

DATE PRINTED 09/01/2011	TERMS OF SALE	SHIP VIA	F.O.B.	FREIGHT TERMS
----------------------------	---------------	----------	--------	---------------

BID OPENING DATE: 09/22/2011 BID OPENING TIME 01:30PM

LINE	QUANTITY	UOP	CAT. NO.	ITEM NUMBER	UNIT PRICE	AMOUNT
BUILDING 15 2019 WASHINGTON STREET, EAST CHARLESTON, WV 25305-0130						
THE BID SHOULD CONTAIN THIS INFORMATION ON THE FACE OF THE ENVELOPE OR THE BID MAY NOT BE CONSIDERED:  SEALED BID  BUYER: CB-23  REQ. NO.: DEP15573  BID OPENING DATE: 09/22/2011  BID OPENING TIME: 1:30 P.M.  PLEASE PROVIDE A FAX NUMBER IN CASE IT IS NECESSARY TO CONTACT YOU REGARDING YOUR BID: 304-425-2171 ----- PLEASE PRINT OR TYPE NAME OF PERSON TO CONTACT CONCERNING THIS QUOTE: M. ADAM SARVER -----						

SEE REVERSE SIDE FOR TERMS AND CONDITIONS

SIGNATURE <i>M. Adam Sarver</i>	TELEPHONE 304-487-3912	DATE 9-22-11
TITLE Member	FEIN 58-2667955	ADDRESS CHANGES TO BE NOTED ABOVE

WHEN RESPONDING TO RFQ, INSERT NAME AND ADDRESS IN SPACE ABOVE LABELED 'VENDOR'

BUYER CB-23	REQ. or P.O. No. DEP 15573
SPENDING UNIT WEST VIRGINIA DEPARTMENT OF ENVIRONMENTAL PROTECTION SPECIAL RECLAMATION	

WV-36 STATE OF WEST VIRGINIA  
 REV. 1/29/02 PURCHASING CONTINUATION SHEET  
 VENDOR:

Directions

Royal Scot Minerals, Inc.

Revoked Permit Number 31-72

In Greenbrier County, from the Rupert Post Office, travel east on U.S. Route 60 approximately 100 feet and turn left onto County Route 1 (Anjean Road). Travel approximately 5.8 miles and turn right at the truck scales. Cross bridge and turn right. Travel approximately 2.7 miles to intersection and turn right through gate and travel approximately 0.6 mile to mine site (Intersection Pond).

Note: Access road is a public road however current mining activities are taking place adjacent to mine site area and haulage equipment may be present. However caution must be taken when traveling on any of the access roads to mine site use of CB radio is advised. Pre-Bid will begin at the Intersection Pond.

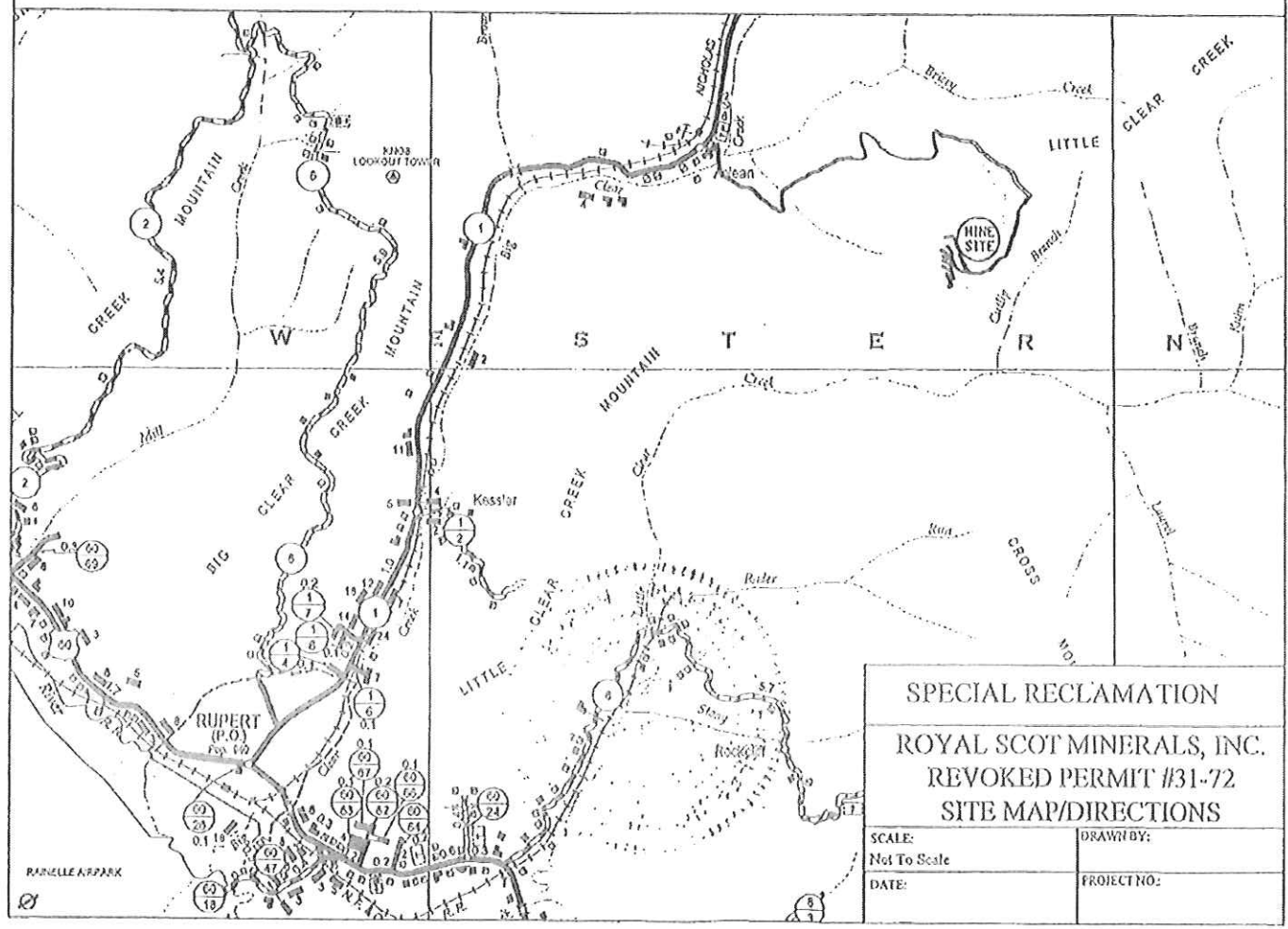

BUYER CB-23	REQ. OR PO NO. DEP15573
SPENDING UNIT WEST VIRGINIA DEPARTMENT OF ENVIRONMENTAL PROTECTION/SPECIAL RECLAMATION	

WV-36a STATE OF WEST VIRGINIA  
REV. 5-26-09 PURCHASING CONTINUATION SHEET  
VENDOR:

### SCOPE OF WORK

The successful bidder shall provide appropriate equipment, materials, labor and any technical services needed for the successful reclamation of Royal Scot Minerals, Inc., Permit 31-72, and any disturbance associated with such operation. The General Performance Standards (GPS) shall apply to all items in Scope of Work.

Work necessary on this site will include the following items, but is not limited to these:

1. Upon mobilization to the site, which will be directed in a written Notice to Proceed, the access roads shall be developed in accordance with bid item #3.0. If fuel and lubricants are to be stored on site, bid item #2.0 shall be in place before fuel is delivered. Project sign shall be constructed and erected in accordance with attached specifications. The sign shall be maintained during construction activities and through the life of the warranty period. Sign cost is a No Bid Item and is included with mobilization cost. No work shall be authorized or allowed at the site until sign is constructed and erected on site and approved by DEP.
2. Storm water management shall be in place using bid items #7.0 & 8.0 in described locations prior to any disturbance of materials or earthwork takes place. See Water Quality Control under the General Performance Standards.
3. It shall be the contractor's responsibility to check for and locate all utilities within the work area to provide and maintain a safe working area in addition to preventing damage to the utility.
4. Construction stakeout as necessary to carry out work. (Bid Item # 5.0 )
5. Remove sludge material from existing Intersection Pond and place material in designated area.
6. If any debris is encountered during sludge removal contractor shall properly dispose of any debris off site. Cost of debris removal shall be incidental to and included in the cost of sludge removal.
7. The Sludge Removal bid item specified by the cubic yard on this project in the Bid Schedule shall require submittal of a final survey to verify the final quantity. Survey shall delineate existing profile of the Intersection Pond prior to sludge removal and profile of Intersection Pond upon completion of sludge removal. This submittal shall include a copy of all field notes and a map to scale in paper form and electronic form. Final survey must be conducted under the direct supervision of, and certified by, a Professional Surveyor or Professional Engineer licensed in the state of West Virginia. Partial payments can be made for estimated quantity that are field verified and agreed upon with the DEP agent on site. Partial payments may not exceed 75 percent of bid item prior to final survey.
8. Install 1,000 linear feet of silt fence/and or haybale dike for sediment control during and after construction. DEP agent onsite will determine where each type will be used.
9. Sediment control sumps shall be constructed for storm-water management upon request of the DEP agent on site. (See details and specifications)
10. Contractor shall place up to 200 tons of crushed stone as directed by WV DEP agent onsite.

I, Nathan L. Parks, the undersigned, hereby certify<sup>1</sup> that this Reclamation Plan is correct and shows to the best of my knowledge and belief all the information required by the surface mining laws of the State of West Virginia. The source of information was the approved mining and reclamation plan contained in the forfeited surface mine permit, existing site conditions and information contained in the WV DEP, Inspection and Enforcement Sites.



Registered Professional Engineer WV No. 17969



Date: 08-23-2011

<sup>1</sup> The term "certify" as used herein is defined as follows: An engineer's certification of conditions is a declaration of professional judgment. It does not constitute a warranty of guarantee either expressed or implied.

BUYER CB-23	REQ. OR PO NO. DEP15573 14
SPENDING UNIT WEST VIRGINIA DEPARTMENT OF ENVIRONMENTAL PROTECTION/SPECIAL RECLAMATION	

WV-36a STATE OF WEST VIRGINIA  
 REV. 5-26-09 PURCHASING CONTINUATION SHEET  
 VENDOR:

ITEM NO.	QUANTITY	DESCRIPTION	UNIT PRICE	AMOUNT
		<b>BID SCHEDULE</b>		
		<b>PERMIT NAME: ROYAL SCOT MINERALS, INC.</b>		
		<b>PERMIT NUMBER(S): 31-72</b>		
The DEP reserves the right to request additional information and supporting documentation regarding unit prices when the unit price appears to be unreasonable.				
1.0	LUMP SUM	<u>MOBILIZATION/DEMobilIZATION/PROJECT SIGN</u> (5% Total Bid Maximum for this permit)	LUMP SUM	\$ <u>4,625.00</u>
2.0	LUMP SUM	<u>SPILL CONTAINMENT AREA (S.C.A.)</u> (\$1,000.00 Maximum Bid for this permit)	LUMP SUM	\$ <u>590.00</u>
3.0	LUMP SUM	<u>HAULROAD/ACCESS ROAD</u> (5% Total Bid Maximum for this permit)	LUMP SUM	\$ <u>8,260.00</u>
4.0	<u>200 TON</u>	<u>INCIDENTAL STONE</u>	\$ <u>19.00</u> PER TON	\$ <u>3,800.00</u>
5.0	LUMP SUM	<u>CONSTRUCTION STAKEOUT</u> (Limited to 5% Total Bid)	LUMP SUM	\$ <u>1,888.00</u>
6.0	<u>45,000 CY</u>	<u>SLUDGE REMOVAL</u>	\$ <u>3.76</u> PER CY	\$ <u>169,200.00</u>
7.0	<u>1,000 LF</u>	<u>SILT FENCE AND HAYBALE DIKE</u> (Max. Bid \$5.00 Per LF)	\$ <u>4.00</u> PER LF	\$ <u>4,000.00</u>
8.0		<u>CONSTRUCTED SEDIMENT CONTROL STRUCTURES</u>		
8.1	<u>20 EA</u>	<u>SEDIMENT CONTROL SUMP</u>	\$ <u>120.00</u> PER EA	\$ <u>2,400.00</u>
9.0	NO BID ITEM	<u>UTILITIES</u>	NO BID ITEM	
<b>TOTAL PERMIT 31-72</b>				\$ <u>194,763.00</u>

BUYER CB-23	REQ. OR PO NO. DEP15573
SPENDING UNIT WEST VIRGINIA DEPARTMENT OF ENVIRONMENTAL PROTECTION/SPECIAL RECLAMATION	

WV-36a STATE OF WEST VIRGINIA  
REV. 5-26-09 PURCHASING CONTINUATION SHEET  
VENDOR:

## **BID ITEM TECHNICAL SPECIFICATIONS**

### **1.0 MOBILIZATION/DEMOBILIZATION/PROJECT SIGN**

A project sign shall be obtained or manufactured and installed as indicated on the attached specifications and details. Payment for this sign shall be incidental to the mobilization item. No separate payment will be made.

This work shall consist of the performance of construction preparatory operations, including the movement of personnel, equipment and other facilities to the project site necessary to begin work on a substantial phase of the contract.

Prior to demobilization, an inspection shall be conducted by the Department of Environmental Protection and the contractor to insure compliance with contract performance. Once compliance is ascertained, demobilization activities can be initiated and completed. Demobilization shall be totally completed before the invoice for payment shall be processed.

The lump sum bid for this item shall not exceed 5% of the total bid for this permit. Payment shall be made in two 50% amounts, one upon completion of the mobilization and project sign items and the second payment at the completion of demobilization. No deduction shall be made nor shall any increase be made in the lump sum item amount, regardless of decreases or increases in the final total contract amount or any other reason.

### **2.0 SPILL CONTAINMENT AREA (S.C.A.)**

Spill containment measures shall be used for fuel and lubricant storage areas. All containers, barrels, buckets, cans, etc., are to be legally disposed of off site. Used lubricants are to be disposed of according to state law to minimize pollution to the local surface and ground water supplies. Spills are the responsibility of the contractor and need immediate clean up and maintained at no expense to the State. This S.C.A. shall be constructed in accordance with the typical drawing specification. (See Attachment) Alternate containment measures will be considered for approval by the Engineer if acceptable results can be shown. Fuel tanks manufactured with secondary containment are desirable. Minimum secondary containment is 110 percent. (Bid limited to \$1,000.00 maximum)

### **3.0 HAULROAD/ACCESS ROAD**

The contractor shall maintain and/or construct haulroad/access road(s) during the reclamation process to provide access on a well drained surface. The access road on the reclamation site shall be graded, sloped, and maintained to drain to provide a road surface free of excessive mud and standing waters at all times while work is in progress. Dust-control measures may be necessary if hauling creates airborne material. Snow removal is to be included in this item.

### **4.0 INCIDENTAL STONE**

During construction of culvert installations, roadway ditch improvements, reshaping of the roadway, rock check dams, and rock filter outlets, and any additional areas that may need stone. Placement and compaction, if required by DEP, shall be incidental to and included in the cost of the Incidental Stone bid item. Gradation and placement as directed by DEP onsite representative.

Payment shall be paid per ton of stone applied by weight ticket and will be made at completion of all work and acceptance by DEP.

### **5.0 CONSTRUCTION STAKEOUT**

This work shall consist of furnishing, placing, and maintaining construction layout stakes necessary for the proper execution of the work required under the Contract, production of as-built drawings, and of performing topographic surveys and obtaining surveyed cross-sections for accurate determination of pay item quantities. Construction stakeout shall be under the supervision of a Registered Professional Engineer or Licensed Land Surveyor and all drawings signed and/or sealed by such. The Department shall provide control points for initial layout of the work. (Shall not exceed 5% of the total bid for this permit.)



BUYER CB-23		REQ. OR PO NO. DEP15573	16
SPENDING UNIT WEST VIRGINIA DEPARTMENT OF ENVIRONMENTAL PROTECTION/SPECIAL RECLAMATION			

WV-36a STATE OF WEST VIRGINIA  
REV. 5-26-09 PURCHASING CONTINUATION SHEET  
VENDOR:

#### A. MATERIALS

Wooden stakes and other marking materials as described herein.

#### B. CONSTRUCTION METHODS

B(1). The Contractor shall locate and reference the construction baseline within the limits of work and shall establish bench marks for the proper layout of the work. The Contractor shall make all calculations involved and shall furnish and place all layout stakes or markers.

B(2). The Contractor shall provide field forces and shall set all additional stakes needed, such as offset stakes, reference point stakes, slope stakes, pavement and grade stakes, stakes for roadway drainage, sub-drains, trench drains, fence, culverts or other structures, supplementary bench marks and any other horizontal or vertical controls necessary to secure a correct layout of the work.

B(3). The location of the slope stakes for grading work shall be determined by a calculation method. Elevation control hubs with guard stakes shall be set, at a convenient distance outside the construction limits, and at all stations where original cross-sections are taken. The centerline station, the distance from centerline, and the elevation of the hub shall be recorded on each guard stake.

B(4). The Contractor shall be responsible for having the layout staking work conform to the lines, grades, elevations, and dimensions called for on the Plans. The Contractor shall be responsible for reporting any discrepancies to the Engineer for clarification. Minor adjustments to suit field conditions are anticipated and it shall be the responsibility of the Engineer to make decisions regarding adjustments.

B(5). The Contractor shall survey cross-sections and/or profiles in areas of on-site excavation, off-site excavation, and ditch construction as necessary to permit accurate determination of pay item quantities. The locations and spacing of cross-sections and profiles shall be as approved or as directed by the Engineer. Cross-sections and profiles shall be surveyed:

- a) prior to any excavation
- b) at the completion of excavation

B(6). The Contractor shall furnish a copy of his survey records for the Engineer and for the DEP's permanent file. These records shall be furnished as they are completed during the progress of the work. Any inspection or checking of the Contractor's layout by the Engineer and the acceptance of all or any part of it shall not relieve the Contractor of his responsibility to secure the proper dimensions, grades and elevations of the required work.

#### 6.0 SLUDGE REMOVAL

Contractor shall remove all sludge material from the Intersection Pond by means of mechanically excavating sludge and transporting to designated area(s). Contractor shall dispose of sludge material in Area A until such time that the Engineer determines that the disposal capacity of Area A is maximized. Contractor shall then, if directed by the Engineer, dispose of remaining sludge in Area B. Contractor may dewater sludge to aid in the removal and transportation of sludge. Any water pumped or otherwise removed from Intersection Pond shall be directed into the existing DEP Bucklilly Pond 1. Prior to any water being directed into DEP Bucklilly Pond 1 coordination with and approval by onsite DEP agent shall be obtained. Means of dewatering Intersection Pond that would allow sludge material to exit Intersection Pond area shall not be permitted. Contractor shall not be permitted to add water to sludge material in an effort to pump sludge material instead of mechanically dipping sludge. Material shall be transported in a manner that prevents sludge material from being spilled onto roadway or ground surfaces prior to placement in designated area(s). Sludge material shall be graded within the designated area(s) in order to prevent water from collecting on sludge material. Contractor shall take all precautions necessary to not damage clay liner(s) and berm(s) in which sludge material shall be placed on and within.

Note: Under this contract contractor is not responsible for constructing clay liner(s) and berm(s) in which sludge material is to be placed. However contractor shall be responsible for repairing any damage to clay liner(s) and

BUYER CB-23	REQ. OR PO NO. DEP15573
SPENDING UNIT WEST VIRGINIA DEPARTMENT OF ENVIRONMENTAL PROTECTION/SPECIAL RECLAMATION	

WV-36a STATE OF WEST VIRGINIA  
REV. 5-26-09 PURCHASING CONTINUATION SHEET  
VENDOR:

berm(s) caused by the contractor.

Payment shall be paid per cubic yard of sludge material removed.

**STRUCTURE AND/OR DEBRIS REMOVAL:**

All existing man-made items particular to the site and not to be utilized in the total reclamation of this site shall be demolished (if necessary) and disposed of in a legal manner. All iron, steel, aluminum, or any other metal, plastic, or any other man made material, including but not limited to I-Beams, Angle Iron, Channel Iron, Corrugated Metal, Flat Metal, Floc Drums, Grease Drums, Tires, Pipe or Conduit is to be dismantled, removed and properly disposed of offsite and according to state, local, and federal requirements. Contractor must provide documentation of proper disposal. Concrete may be broken into sections no larger than four feet in any direction and buried on site. Any rebar or reinforcing steel shall be removed to be flush with the surface of the concrete prior to burial and disposed of offsite. Cost of debris removal shall be incidental to and included in the cost of Sludge Removal.

**7.0 SEDIMENT CONTROL WITH SILT FENCE AND HAYBALE DIKE**

Disturbed areas which have storm water runoff and do not pass through a sediment control structure or other areas where excess sedimentation is to be controlled shall utilize the following Best Management Practice (BMP) methods to manage storm water runoff. (For more information on BMP methods go to the WVDEP website <http://www2.wvdep.org/dwwwm/stormwater/BMP.htm> and click on BMP Manual. The WV Erosion and Sediment Control Best Management Practice Manual may be accessed or printed.)

The drawings and specifications are prepared with all sediment controls anticipated to keep the project within the requirements of the approved plan. However, any adjustments needed to be made to this plan during the execution of this project in order to maintain, at a minimum, compliance with said permit shall be the Contractor's responsibility and expense at no additional cost to WVDEP. Any adjustments to the sediment controls described herein will be at the discretion and prior approval of the WVDEP on-site representative.

This item has a Maximum Bid of \$5.00/LF of silt fence and hay bale material installed on site.

CONSTRUCTION - Approximately 1000 LF of silt fence and hay bale dike are proposed for this project, as shown on the attached site plan. Construction of all sediment controls shall comply with the following:

1. Silt fence shall be utilized on perimeter barriers and internally as shown on the plans or as determined necessary by WV DEP agent onsite. Silt fence shall be properly removed after permanent vegetation has been established, as directed by the WVDEP designated on-site representative. Silt fence shall be installed per the manufacturer's recommendations. See the attached drawing for further details.
2. Silt fence shall be placed on the contour. On slopes with grades greater than seven (7%) percent, the silt fence should be located at least five (5) to seven (7) feet beyond the base. Turn the ends of the silt fence upslope so that a certain depth of storm water may be retained in front of the silt fence. The impounded depth should be at least twelve (12) inches, but no more than the height of the silt fence. Hay bale dike shall be staked in place at the end of the row of silt fence as an emergency overflow. This will allow detained water, exceeding the capacity of the silt fence, to be filtered and released quickly. Silt fence shall not be installed in streams or swales or in any area where there is a reasonable chance of concentrated flow. In areas where concentrated flows can be expected, use haybale dike with the construction of sumps. The bottom edge of silt fence shall be entrenched and backfilled.
3. The silt fence should be purchased in a continuous roll cut to the length of the barrier to avoid the use of joints. When joints are unavoidable, filter cloth should be spliced together only at a supporting post, with a minimum six (6) inch overlap and securely sealed with a sewn seam or two supporting posts and the attached silt fence may be butted together and twisted, prior to supporting posts being driven. See Silt Fence Details and installation requirements. Payment for silt fence will be per linear foot installed excluding laps. Cost of the silt fence shall include the removal from the project upon stabilization and permanent vegetation being established.

BUYER CB-23		REQ. OR PO NO. DEP15573 18
SPENDING UNIT WEST VIRGINIA DEPARTMENT OF ENVIRONMENTAL PROTECTION/SPECIAL RECLAMATION		

WV-36a STATE OF WEST VIRGINIA  
REV. 5-26-09 PURCHASING CONTINUATION SHEET  
VENDOR:

4. Rock filtered outlets are to be placed in the silt fencing as needed to control areas exhibiting concentrated flows to prevent breaching of the fence. Outlets are to be placed at locations per direction of the DEP on-site representative. See attached detail 'Rock Filter Outlets'.
5. Hay bales shall be utilized on internal areas, as a supplement to silt fencing, to control areas where excess runoff may create excessive erosion and instability, per the direction of the DEP on-site representative. For slope stability, place bales on the contour; at the top of cuts; and at the toe of slopes. Bales shall be placed in a row with ends tightly abutting the adjacent bales.
6. Bales shall be placed on unbound edge and securely anchored in place by stakes driven through the bales. Rebar shall not be permitted for use as stakes. Stakes shall be removed after permanent vegetation has been established, as directed by the WVDEP designated on-site representative. The first stake in each bale shall be driven toward previously laid bale to force the bales together. See attached drawing for further details.
7. Construction of sediment control sumps before culvert inlets and/or rock check dams in ditch lines (see attached drawing) may become necessary to supplement the silt fence and hay bale dikes. These items shall be installed as shown on the attached plans and at other determined locations upon request of the WVDEP designated onsite representative. Installation of small sumps and rock check dams shall be incidental to this bid item.

**INSPECTION** - Inspect all erosion and sediment controls before anticipated storm events (or series of storm events such as intermittent showers over one or more days) and within twenty-four (24) hours after the end of a storm event greater than 0.5 inches per 24-hour period, and at least once every seven (7) calendar days. Where sites have been finally or temporarily stabilized, such inspection may be conducted only once per month.

**MAINTENANCE** - Sediment should be removed once it has accumulated to one-half (1/2) the original height of the barrier or one-half (1/2) the sediment capacity of any particular control structure. Filter fabric should be replaced whenever it has deteriorated to such an extent that the effectiveness of the fabric is reduced (approximately six (6) months). Silt fence should remain in place until disturbed areas have been permanently stabilized. All sediment accumulated at the fence should be removed and properly disposed of before the fence is removed.

**PAYMENT** - Payment will be by the linear foot installed. Price of the silt fence and hay bales shall include the removal of all such materials from the project upon stabilization and permanent vegetation being established, per direction of the DEP on-site representative.

#### **8.0 CONSTRUCTED SEDIMENT CONTROL STRUCTURE**

A sediment control structure shall be constructed as per attached detailed plans. Such structures shall be cleaned out when the sediment capacity reaches 60%, repaired, and maintained until demobilization. This item will be a one-time payment. Clean-out and maintenance shall be conducted by the contractor at no expense to DEP. (SEE ATTACHMENT)

#### **9.0 UTILITIES**

Utilities shall be relocated, if necessary, at the direction of the utility company and reimbursed actual cost to the contractor. This is a "No Bid" item due to the method of reimbursement. It is the contractor's responsibility to determine the exact location of each utility in the project area where these utilities would be interrupted or damaged by performing work.

BUYER CB-23	REQ. OR PO NO. DEP15573
SPENDING UNIT WEST VIRGINIA DEPARTMENT OF ENVIRONMENTAL PROTECTION/SPECIAL RECLAMATION	

WV-36a            STATE OF WEST VIRGINIA  
REV. 5-26-09    PURCHASING CONTINUATION SHEET  
VENDOR:

## **BID PREPARATION INFORMATION**

### **HISTORICAL INFORMATION**

Prospective bidders may review files at the West Virginia Department of Environmental Protection, Charleston, WV office, or the Regional West Virginia Department of Environmental Protection Office at 254 Industrial Drive, Oak Hill, WV 25901. These files may contain additional information not included in the contract. Documents including, but not limited to, permit applications, permits, inspection reports, environmental documents, permit violation history, geological and geotechnical information, probable hydrologic consequences, maps, modifications, NPDES information and other related data. Copies may be obtained upon request and payment of copying fees.

### **EXAMINATION OF BID PACKAGE AND SITE OF WORK**

The bidder is required to examine, carefully, the bid package (plans, specifications, supplemental specifications, contract forms, etc.) and the site of the work contemplated. The submission of a bid shall be considered prima facie evidence that the bidder has made such examination and has judged for and satisfied themselves as to the character, quantity, and quality of work to be performed and the materials required to be furnished under the contract.

### **PREBID CONFERENCE**

Only the prospective bidders on the sign-in sheet in attendance for the entire Pre-Bid Conference will be eligible to submit bids for consideration of this project. Considerable foot travel over rough terrain and/or inclement weather may be required.

### **VIDEO**

The information given at the pre-bid showing by the project contact person or the assigned person shall be documented on video tape and shall be an integral part of this contract's requirements, but will not supersede the written contract. All information on video tape that is new or provides clarification to the specifications, will be issued in writing by a formal addendum and will become part of the written contract.

### **INTENT OF CONTRACT**

The intent of the contract is for the reclamation/restoration of forfeited mine lands as required by West Virginia Department of Environmental Protection. The contractor is to provide for the construction and completion in every detail of the work described. The Contractor shall furnish all labor, materials, equipment, tools, transportation, and supplies required to complete the work in accordance with the Plans, Specifications, and terms of the Contract.

Should any misunderstanding arise as to the intent or meaning of the Contract, or any discrepancy appear, the decision of the Director of Division of Land Restoration shall be final.

BUYER CB-23		REQ. OR PO NO. DEP15573 20
SPENDING UNIT WEST VIRGINIA DEPARTMENT OF ENVIRONMENTAL PROTECTION/SPECIAL RECLAMATION		

WV-36a STATE OF WEST VIRGINIA  
 REV. 5-26-09 PURCHASING CONTINUATION SHEET  
 VENDOR:

## GENERAL PERFORMANCE STANDARDS

### INTRODUCTION

The performance standards and non-compliance penalties which govern special reclamation-bond forfeiture projects are in Chapter 22A, Article 3, of the Code of West Virginia and subsequent rules and regulations. The following performance standards are of a general nature and do not represent all the performance standards applicable to a special reclamation-bond forfeiture project. However, some or all of these standards will pertain to each project.

### BACKFILLING

1. Unless otherwise noted, the highwall shall be eliminated and the disturbed area graded to the approximate original contour.
2. The material used to backfill and eliminate the highwall shall be sufficiently compacted so as to insure stability of the backfill throughout the warranty period.
3. The land above the highwall shall not be disturbed unless otherwise directed.
4. The best available material to support vegetation, sufficient to establish a permanent vegetative cover and to achieve the approved post mining land use, shall be used.

### BLASTING

The performance standards of the blasting regulations must be adhered to.

### LIFE OF CONTRACT

The purchase order contract becomes effective on the starting date as specified in the notice to proceed as issued by the Department of Environmental Protection. This contract extends for a period of one (1) year and may be renewed until such "reasonable time" thereafter as is necessary to complete the payment therefore. A responsible Contractor's Agent shall be on the site at all working times who demonstrates a knowledge of mined land reclamation, contract requirements and responds to DEP (owner) inspections.

### WORK PERFORMANCE PERIOD

The work performance period is a defined portion of the contract in which all items shall be completed. The work performance period is to be performed within 365 calendar days. Extensions may be granted based upon contractor's performance, weather conditions and site-specific site conditions.

### NOTICE TO PROCEED

A notice to proceed shall be issued to the Contractor by the project contact person for the Department of Environmental Protection. Actual construction may only begin after a Notice to Proceed is given and as specified. Such notice shall specify the starting date of the Purchase Order, the work performance period, and the completion date of the work performance period.

BUYER CB-23		REQ. OR PO NO. DEP15573
SPENDING UNIT WEST VIRGINIA DEPARTMENT OF ENVIRONMENTAL PROTECTION/SPECIAL RECLAMATION		

WV-36a            STATE OF WEST VIRGINIA  
REV. 5-26-09    PURCHASING CONTINUATION SHEET  
VENDOR:

### PRE-CONSTRUCTION CONFERENCE

The Contractor in possession of the awarded purchase order shall schedule a Pre-Construction Conference on the site within ten (10) days after receiving the Notice To Proceed. The Contractor's foreman or the on-the-ground supervisor must be in attendance.

### GENERAL SUPERVISION

This contract is under the general supervision of the West Virginia Department of Environmental Protection's contact person for the purpose of contract compliance inspection only. Contractor shall supervise work being conducted at all times. All services rendered by the Engineer/Contact Person consist of professional opinions and recommendations made in accordance with generally accepted engineering practice. Under no circumstances is it the intent of the Engineer/Contact Person to directly control the physical activities of the Contractor or the Contractor's workmen's accomplishment of work on this project.

### CONTRACTOR RESPONSIBILITY

The contractor is responsible for compliance with all aspects of this written contract. No changes will be honored without prior approval from the Engineer.

### LAWS TO BE OBSERVED

The Contractor shall keep fully informed of all Federal and State laws, all local laws, ordinances, and regulations and all orders and decrees of bodies or tribunals having any jurisdiction or authority, which in any manner affect those engaged or employed on the work, or which in any way affect the conduct of the work. The Contractor shall at all times observe and comply with all such laws, ordinances, regulations, orders and decrees; and shall protect and indemnify the State and its representatives against any claim or liability arising from or based on the violation of any such laws, ordinances, regulations, orders, or decrees, whether by themselves, their subcontractors or their employees.

### PERMITS, LICENSES AND TAXES

The Contractor shall procure all permits and licenses, pay all charges, fees, and taxes, and give all notices necessary and incidental to the due and lawful prosecution of the work.

### CONCURRENT RECLAMATION

Reclamation of this project shall commence at a definite point as defined and shall progress from that point with total reclamation to include backfilling, grading/regrading, and revegetation. Changes may be granted based upon weather or differing site conditions with prior approval.

### WATER QUALITY CONTROL

Shall commence with initial start-up of the project and remain in effect for the extent of the backfilling, regrading and revegetation activity. The Contractor is responsible for performing the best management practices. Adequate facilities shall be installed, operated and maintained using the best management practices of the U.S. Environmental Protection Agency's Non-Point Source (NPS) Program for sediment control during the active reclamation. The contractor shall take any and all steps necessary to prevent erosion or silting problems from occurring and to minimize pollution or sedimentation of the stream. If any such problems develop, the contractor shall be responsible to take immediate corrective action. No separate payment for this work will be honored. All impounded waters which require removal during reclamation, shall be pumped with appropriate measures taken to prevent erosion from the discharge. The contractor shall be responsible for treatment of said waters to meet pH standards. The water shall be discharged only when the quality meets a pH equivalent to the pH of the receiving stream but not less than 6.0.

BUYER CB-23		REQ. OR PO NO. DEP15573 22
SPENDING UNIT WEST VIRGINIA DEPARTMENT OF ENVIRONMENTAL PROTECTION/SPECIAL RECLAMATION		

WV-36a STATE OF WEST VIRGINIA  
REV. 5-26-09 PURCHASING CONTINUATION SHEET  
VENDOR:

### DIFFERING SITE CONDITIONS

During the progress of the work, if subsurface or latent physical conditions are encountered at the site differing materially from those indicated in the contract or if unknown physical conditions of an unusual nature, differing materially from those ordinarily encountered and generally recognized as inherent in the work provided by the contract, are encountered at the site, the party discovering such conditions shall promptly notify the other party in writing of the specific differing conditions before they are disturbed and before the affected work is performed.

Upon written notification, the Engineer/Contact Person will investigate the conditions, and if determined that the conditions materially differ and cause an increase or decrease in the cost or time required for the performance of any work under the contract, an adjustment, excluding loss of anticipated profits, will be made and the contract modified in writing accordingly. The Engineer/Contact Person will notify the Contractor of DBP's determination whether or not an adjustment of the contract is warranted.

No contract adjustment which results in a benefit to the Contractor will be allowed unless the Contractor has provided the required written notice.

No contract adjustment will be allowed under this clause for any effects caused on unchanged work.

### HANDLING AND STORAGE OF MATERIALS

Materials which are stored on site, before utilization, shall be stored so as to assure the preservation of their quality and fitness for the work. Stored materials, even though approved before storage, may be inspected again prior to their use in the work. Damaged or deteriorated materials shall be removed and replaced by materials meeting the original specifications.

Aggregate stockpiles shall be made on ground that is denuded of vegetation, hard, and well drained. Removal of aggregate from the stockpile shall be done in a manner which will not result in the inclusion of foreign material into the aggregate. The use of the aggregate will determine if exceptions are permitted.

All materials shall be handled in such a manner as to preserve their quality and fitness for the work.

### MAINTENANCE DURING CONSTRUCTION

The contractor shall maintain the work during construction and until the project is accepted. All cost of maintenance work during construction and before the project is accepted shall be included in the unit or lump sum prices on the various pay items.

### FINAL INSPECTION

A final inspection meeting by the Department of Environmental Protection's Specialist and the contractor is required for the construction phase and prior to demobilization.

### ACREAGE QUANTITIES

The acreage quantities in this contract are for bidding purpose and are set (definite) number for the project area as specified at the pre-bid showing. Only surveyed acreage's through figures the Contractor and/or the State develops will be honored to alter these acreage numbers.

### PAYMENT

Invoices must be submitted on prescribed Department of Environmental Protection, Special Reclamation Program forms and include verification. Certified contractor payrolls for operators directly involved in this project and a current workers compensation certificate must accompany each invoice for payment. Verification of wage rates may include employee interviews. Invoices shall be signed in blue ink so that it is easy to verify that document is an original. Vendor should submit with their bid the current remit-to address to be used for payment processing.

MOBILIZATION/DEMOLIBILIZATION shall be invoiced at fifty percent (50%) with the first invoice and the last 50% invoiced after demobilization and acceptance of the road abandonment or final invoice. Demobilization must have written approval.

SPILL CONTAINMENT AREA shall not exceed \$1,000.00 and will be payable in two payments. The first

BUYER CB-23		REQ. OR PO NO. DEP15573
SPENDING UNIT WEST VIRGINIA DEPARTMENT OF ENVIRONMENTAL PROTECTION/SPECIAL RECLAMATION		

WV-36a STATE OF WEST VIRGINIA  
REV. 5-26-09 PURCHASING CONTINUATION SHEET  
VENDOR:

fifty percent (50%) payable with the first invoice and the remainder payable when all fuel tanks, containers and etc., are removed from the site.

Lump sum items shall be percentage payments based on work completed at time of invoice and paid upon acceptance by the Department of Environmental Protection.

Unit items shall be invoiced by specified units completed and accepted by the DEP.

ROAD ABANDONMENT shall be included in the final construction invoice.

#### FAILURE TO COMPLETE ON TIME AND LIQUIDATED DAMAGES

Time is an essential element of the Contract and it is important that the work be completed within the time specified. The cost to the Department of the administration of the Contract, including engineering, inspection and supervision, will increase as the time required to complete the work is increased.

The work performance period as specified in the contract's Notice to Proceed shall be complied with or result in liquidated damages. Such damages shall be assessed at an amount of two hundred and fifty dollars (\$250.00) per day for each and every day beyond the work performance period as specified in the Notice to Proceed. The total amount of daily charges will be deducted from any moneys due the Contractor, not as a penalty but as liquidated damages.

#### REVEGETATION AND WARRANTY

The seeding date shall be at the discretion of the contractor once an approved seedbed has been prepared. In all cases a permanent vegetative cover capable of supporting the post-mining land use must be established. A warranty period of one (1) year shall commence upon completion and payment of the revegetation item of the contract. No payment will be made for additional seeding necessary to comply with warranty requirements. The performance bond and labor and materials bond shall remain in effect throughout the warranty period. The Standards for Evaluating Vegetative Cover as presented in Title 38, CSR2, Section 9 of the West Virginia Surface Mining Reclamation Regulations will apply.

Equipment for the retracking/scarification to eliminate rills and gullies shall be mobilized and utilized to produce slopes consistent with the regrading and topsoiling bid item prior to warranty reseeding. No additional payment will be made by DEP for this warranty work.

Water utilized for hydroseeding shall be free of injurious or other toxic substances harmful to plant life. The source of water is subject to the approval of the DEP contact person.

#### CONTRACT NON-COMPLIANCE

If in the opinion of the Department of Environmental Protection the contract is not in compliance with any line item specification, that portion of the project shall cease until a compliance schedule and understanding is demonstrated in writing and accepted by the Director of Division of Land Restoration.

#### CONTRACT DELETIONS

Any line item, or any portion thereof, may be deleted when determined by the project contact person that such line item, or portion thereof, is deemed unnecessary for the successful reclamation of this project. No claim for loss of anticipated profits will be considered.

#### CANCELLATION

The performance of work under contract may be terminated by the State in whole, or from time to time in part whenever the State shall determine that such termination is in the best interest of the State. Any such termination shall be effected by delivery to the Contractor of a Notice of Termination specifying the extent to which performance of work under the Contract is terminated and the date upon which such termination becomes effective.

When contracts, or any portion thereof, are terminated before completion of all items of work in the Contract, payment will be made for the actual number of units or items of work completed and accepted at the contract unit price. No claim for loss of anticipated profits will be considered. Reimbursement for organization of



BUYER CB-23		REQ. OR PO NO. DEP15573 24
SPENDING UNIT WEST VIRGINIA DEPARTMENT OF ENVIRONMENTAL PROTECTION/SPECIAL RECLAMATION		

WV-36a            STATE OF WEST VIRGINIA  
REV. 5-26-09    PURCHASING CONTINUATION SHEET  
VENDOR:

the work, when not otherwise included in the Contract, and moving equipment to and from the job will be considered where the volume of work completed and accepted is too small to compensate the Contractor for these expenses under the contract unit prices, the intent being that an equitable settlement will be made with the Contractor.

Termination of the Contract or a portion thereof shall not relieve the Contractor of his responsibilities for the completed work, nor shall it relieve his surety of its obligation for and concerning any just claims arising out of the work performed.

This contract may be cancelled in whole or in part in writing by the Director of Purchasing, without prejudice to any other right or remedy it may have, provided that the contractor is given not less than thirty (30) calendar days written notice, (delivered by certified mail, return receipt requested) of intent to terminate. This contract objective is to comply with the reclamation laws of this state and must be expedient to meet the time requirements for reclamation of revoked surface mine permits.

BUYER CB-23	REQ. OR PO NO. DEP 15573
SPENDING UNIT WEST VIRGINIA DEPARTMENT OF ENVIRONMENTAL PROTECTION/SPECIAL RECLAMATION	

WV-36a STATE OF WEST VIRGINIA  
 REV. 5-26-09 PURCHASING CONTINUATION SHEET  
 VENDOR:

S

Attn:

A

Re Notice to Proceed  
 Permit Name: \_\_\_\_\_  
 Permit No. \_\_\_\_\_  
 Purchase Order No.: DEP

Dear :

M

The purpose of this letter is to express our appreciation for your work in advance and to recognize a reclamation partnership project. The initial start-up date for the above mentioned purchase order is . The work performance period must be completed by . The contract life of one year is provided to accomplish all line items and to process all payments within that period.

P

You must schedule a pre-construction conference on site within ten (10) days after receiving this notice to proceed. It is then mandatory that construction begin within ten (10) days of the pre-construction conference and continues diligently until completion of the project. Please contact this office to schedule the pre-construction conference. The foreman, superintendent or on-the-ground supervisor must be in attendance at this conference.

Failure to comply with this notice to proceed will cause termination of the contract and forfeiture of your performance bond.

If you have any questions please feel free to contact this office.

L

Sincerely,

E

WV-36  
 REV. 1/29/02  
 VENDOR:

STATE OF WEST VIRGINIA  
 PURCHASING CONTINUATION SHEET

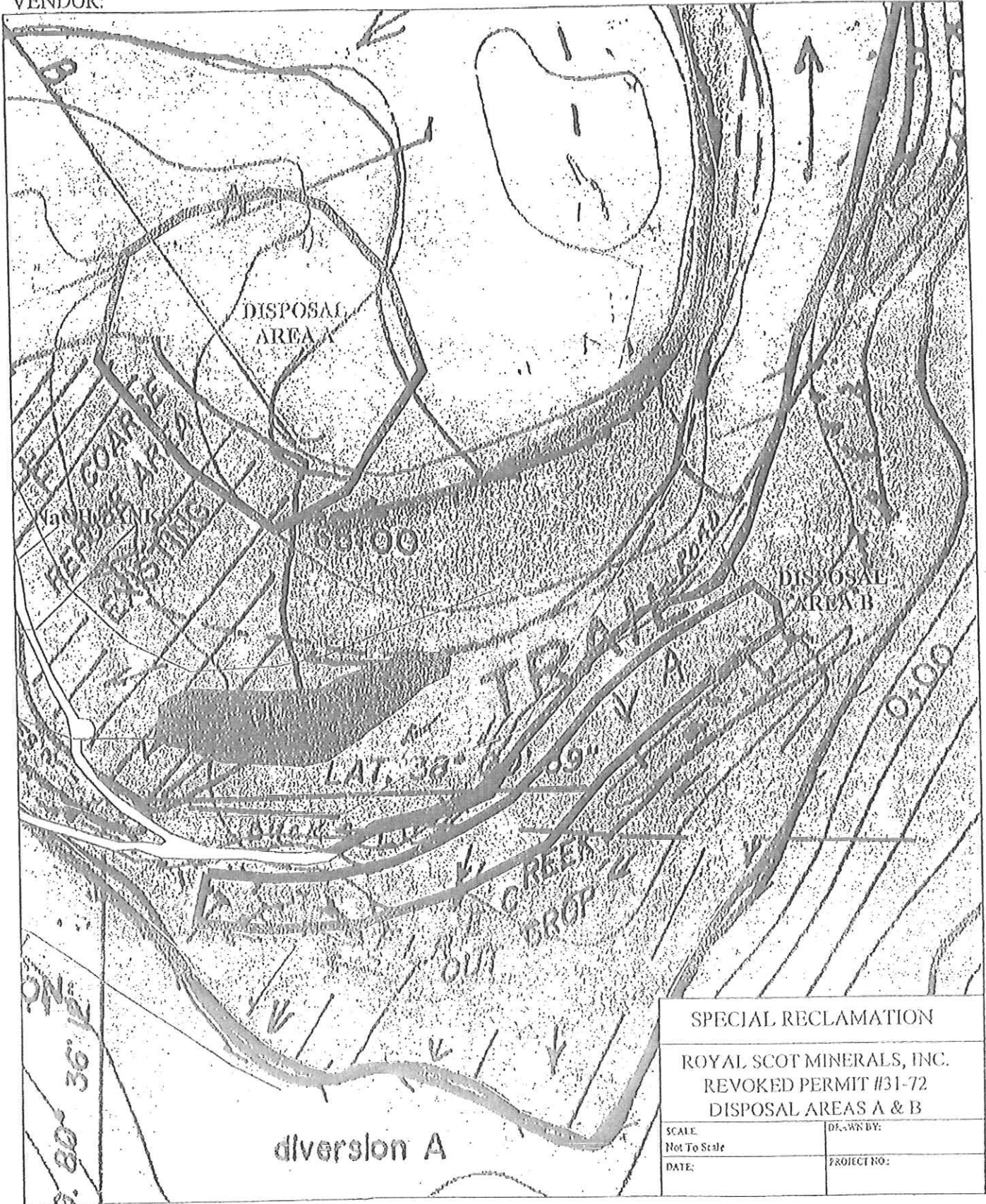

SPECIAL RECLAMATION	
ROYAL SCOT MINERALS, INC.	
REVOKED PERMIT #31-72	
DISPOSAL AREAS A & B	
SCALE: Not To Scale	DE. BY:
DATE:	PROJECT NO.:

27  
WV-36  
REV. 1/29/02  
VENDOR:

STATE OF WEST VIRGINIA  
PURCHASING CONTINUATION SHEET

BUYER  
CB-23

DEP15573

SPENDING UNIT  
WEST VIRGINIA DEPARTMENT OF ENVIRONMENTAL PROTECTION/  
SPECIAL RECLAMATION

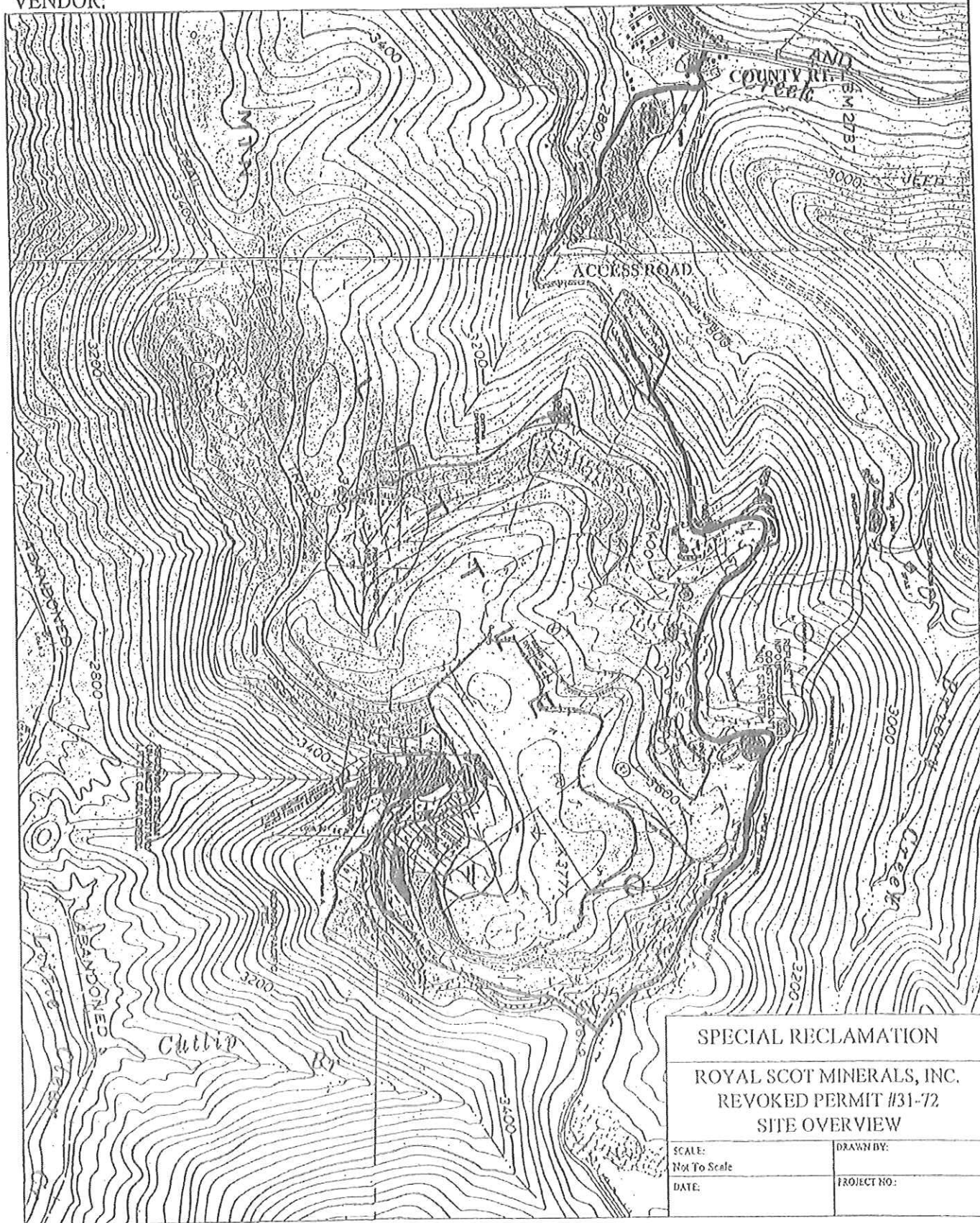

BUYER  
CB-23

REQ. or P.O. No.  
DEP15573

SEDIMENT CONTROL SUMP

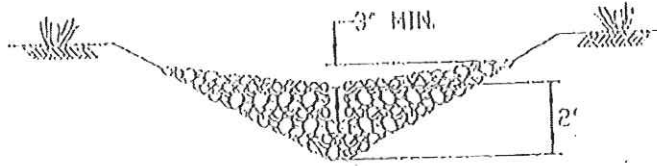

SECTION A-A

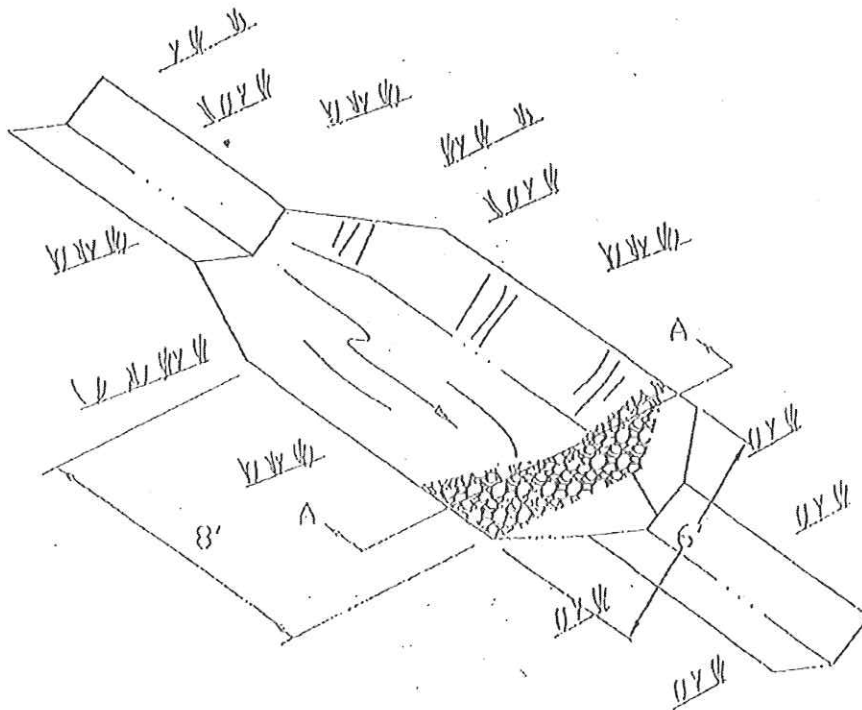

NOTE:

THE SUMP MUST BE CLEANED WHEN 60% FULL.  
ROCK OR HAYBALES SHALL BE PLACED AT SUMP OUTLET.  
THE MINIMUM DITCH DEPTH IS 1.0', AND THE MINIMUM SUMP  
DEPTH IS 4.0'.

SPECIAL RECLAMATION

ROYAL SCOT MINERALS, INC.  
REVOKED PERMIT No. 31-72  
SEDIMENT CONTROL SUMP

SCALE  
Not To Scale  
DATE

DRAWN BY  
PROJECT NO.

29  
WV-36  
REV. 1/29/02  
VENDOR:

STATE OF WEST VIRGINIA  
PURCHASING CONTINUATION SHEET

BUYER CB-23	REQ. or P.O. No. DEP15573
SPENDING UNIT WEST VIRGINIA DEPARTMENT OF ENVIRONMENTAL PROTECTION SPECIAL RECLAMATION	

### SILT FENCE

NOTE:  
THE MAXIMUM LENGTH  
OF SLOPE ABOVE  
A ROW OF SILT  
FENCE IS 110'

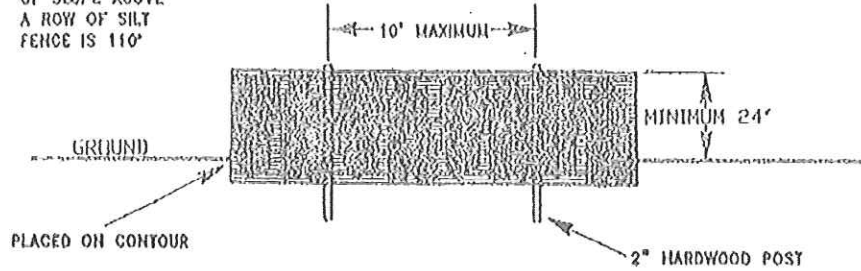

FRONT ELEVATION

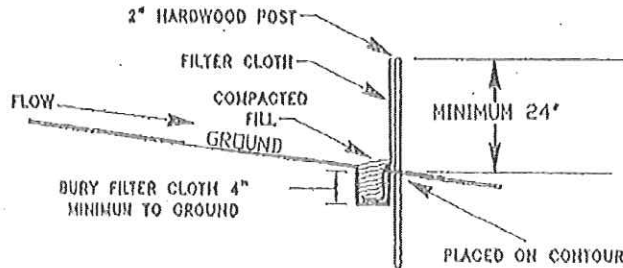

SIDE ELEVATION



TOP VIEW

#### SPECIAL RECLAMATION

ROYAL SCOT MINERALS, INC.  
REVOKED PERMIT No. 31-72  
SILT FENCE TYPICAL

SCALE: Not To Scale	DRAWN BY:
DATE:	PROJECT NO.:

WV-36  
REV. 1/29/02  
VENDOR:

STATE OF WEST VIRGINIA  
PURCHASING CONTINUATION SHEET

SPENDING UNIT  
WEST VIRGINIA DEPARTMENT OF ENVIRONMENTAL PROTECTION  
SPECIAL RECLAMATION

### PLACEMENT OF SILT FENCE

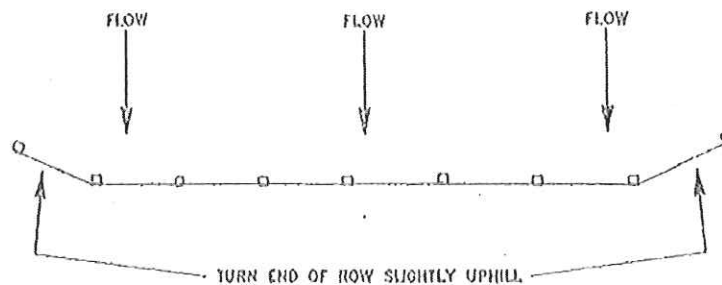
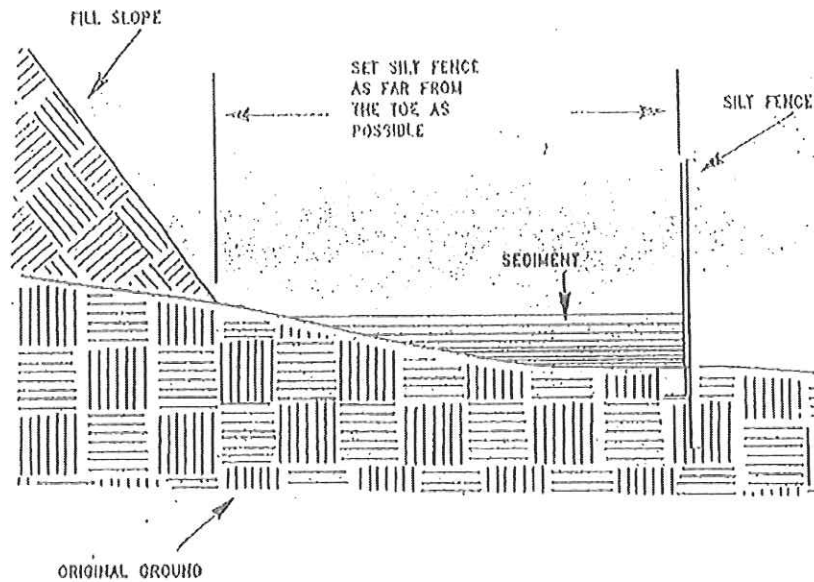

#### SPECIAL RECLAMATION

ROYAL SCOT MINERALS, INC.  
REVOKED PERMIT No. 31-72  
SILT FENCE TYPICAL

SCALE:  
Not To Scale  
DATE:

DRAWN BY:  
PROJECT NO.:

31

WV-36

REV. 1/29/02

VENDOR:

STATE OF WEST VIRGINIA

PURCHASING CONTINUATION SHEET

BUYER CB-23	REQ. or P.O. No. DEP15573
SPENDING UNIT WEST VIRGINIA DEPARTMENT OF ENVIRONMENTAL PROTECTION SPECIAL RECLAMATION	

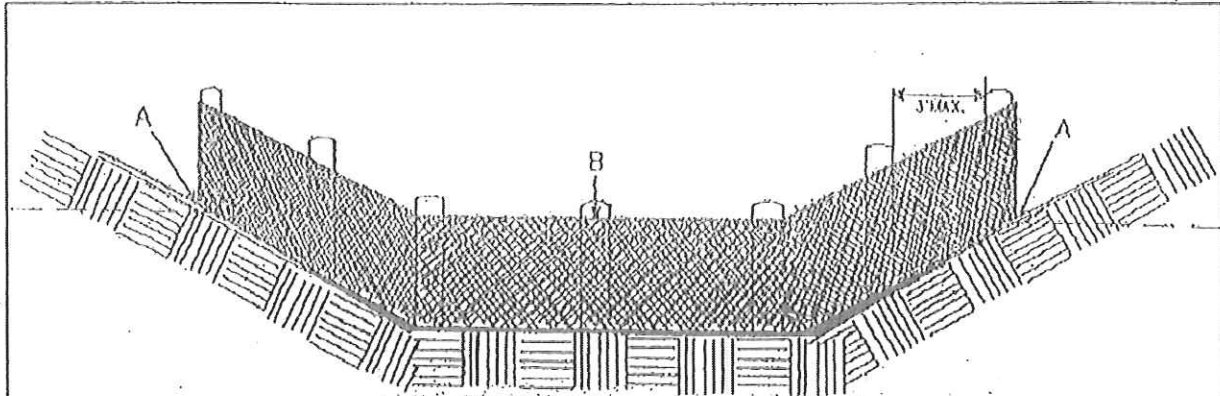

POINTS A SHOULD BE HIGHER THAN POINT B.  
DRAINAGEWAY INSTALLATION  
(FRONT ELEVATION)

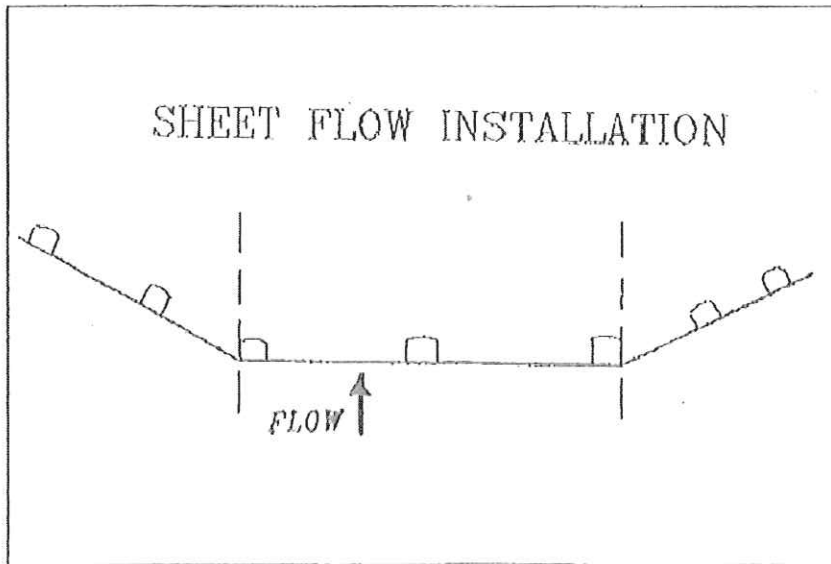

SHEET FLOW INSTALLATION

SPECIAL RECLAMATION

ROYAL SCOT MINERALS, INC.

REVOKED PERMIT No. 31-72

SILT FENCE TYPICAL

SCALE:

Not To Scale

DRAWN BY:

DATE:

PROJECT NO.:



ANGLE FIRST STAKE TOWARD  
PREVIOUSLY LAID BALES

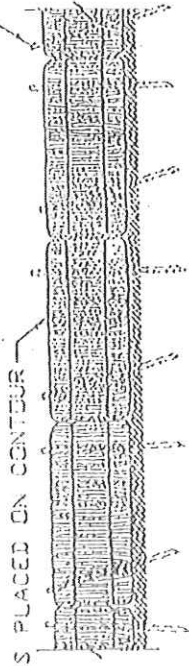

BUND BALES PLACED ON CONTOUR

2" x 2" STAKES MINIMUM OF 4' INTO GROUND

ANCHORING DETAIL

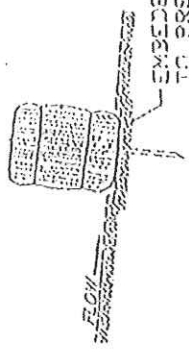

EMBEDDED AS SITE CONDITIONS DICTATE  
TO PREVENT FLOW UNDER BALES.

END VIEW

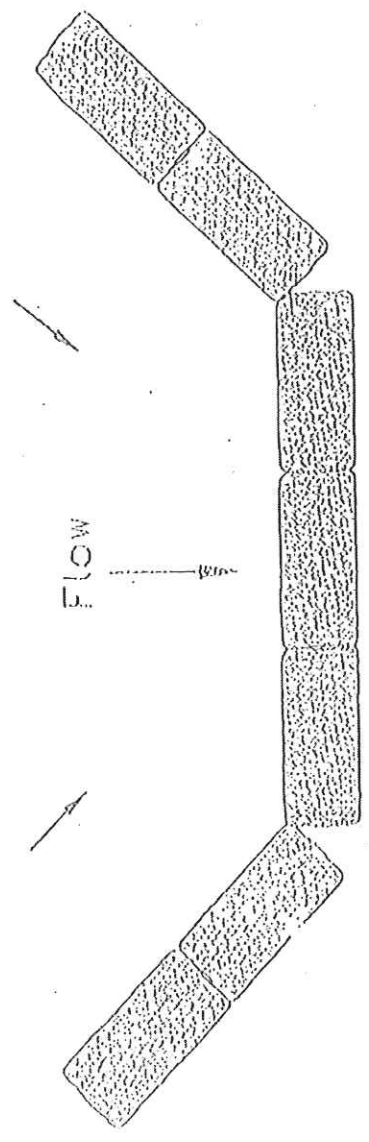

DESIGN TO FIT SITE CONDITIONS

SEDIMENT BARRIER  
TOP VIEW

NOT TO SCALE

BUYER :  
CB-23

REQ. or P.O. No.  
DEP15573

HAY/STRAW BALE DIKE  
SEDIMENT CONTROL

WV-36a STATE OF WEST VIRGINIA  
 REV. 5/26/09 PURCHASING CONTINUATION SHEET  
 VENDOR:

BUYER CB-23		REQ. OR PO NO. DEP 15573
SPENDING UNIT WEST VIRGINIA DEPARTMENT OF ENVIRONMENTAL PROTECTION / OFFICE OF SPECIAL RECLAMATION		

General Requirements

**PROJECT CONSTRUCTION SIGN**

***WORK REQUIRED***

The work to be performed under this Section consists of providing all labor, material and equipment necessary to install a project sign as indicated on the detail included herein and as specified herein.

***MATERIALS***

Paint. Paint for the project sign shall be one (1) coat Exterior-Grade Wood Primer- Sealer, and two (2) coats Exterior-Grade Enamel by Glidden or equivalent.

Wood. Sign face shall be 3/4" X 4' X 8' Marine Exterior plywood, and posts and cross braces shall be treated.

Hardware. All hardware shall be manufactured from good, commercial-quality material and be rust resistant such as galvanized coated.

***EXECUTION***

**PROJECT SIGN**

The signboard shall be cut to the dimensions shown on the details herein. The sign shall be painted with one (1) coat of primer and two (2) coats of white enamel. All exterior cut edges shall be smooth sanded prior to painting. All edges shall be double primed. The letters, border and strips shall be painted as shown on the detail drawing.

The Contractor shall bolt the sign to posts and provide required cross bracing. The posts and sign shall be erected and posts set in gravel base, as shown on the drawings. One (1) sign is required and is to be located at the direction of WVDEP.

**PAYMENT**

Payment for the work which shall include installation of the project sign shall be incidental to the lump sum bid item for "Mobilization/Demobilization"

**NOTE**

No construction work shall commence prior to the project sign being installed.

WV-36a STATE OF WEST VIRGINIA  
REV. 5/26/09 PURCHASING CONTINUATION SHEET  
VENDOR:

BUYER CB-23	PAGE 23	REQ. OR PO NO. DEP 15573
SPENDING UNIT WEST VIRGINIA DEPARTMENT OF ENVIRONMENTAL PROTECTION OFFICE OF SPECIAL RECLAMATION		



Earl Ray Tomblin,  
Governor



Randy C Huffman,  
Cabinet Secretary

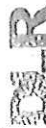

Ken Ellison,  
Director

STATE OF WEST VIRGINIA  
DEPARTMENT OF ENVIRONMENTAL PROTECTION

Division of Land Restoration  
Office of Special Reclamation

Project Cost: \$XXX,XXX.00  
Funding provided by the Special Reclamation Coal Tax paid by WV Coal Mine Companies

Permit Name  
Permit Number

Contractor: Joe Smith Contracting  
Project Start Date: 01/01/01

WV-36a STATE OF WEST VIRGINIA  
 REV. 5/26/09 PURCHASING CONTINUATION SHEET  
 VENDOR:

BUYER CB-23	PAGE 24	REQ. OR PONO. DEP 15573
SPENDING UNIT WEST VIRGINIA DEPARTMENT OF ENVIRONMENTAL PROTECTION/OFFICE OF SPECIAL RECLAMATION		

77 1/4"

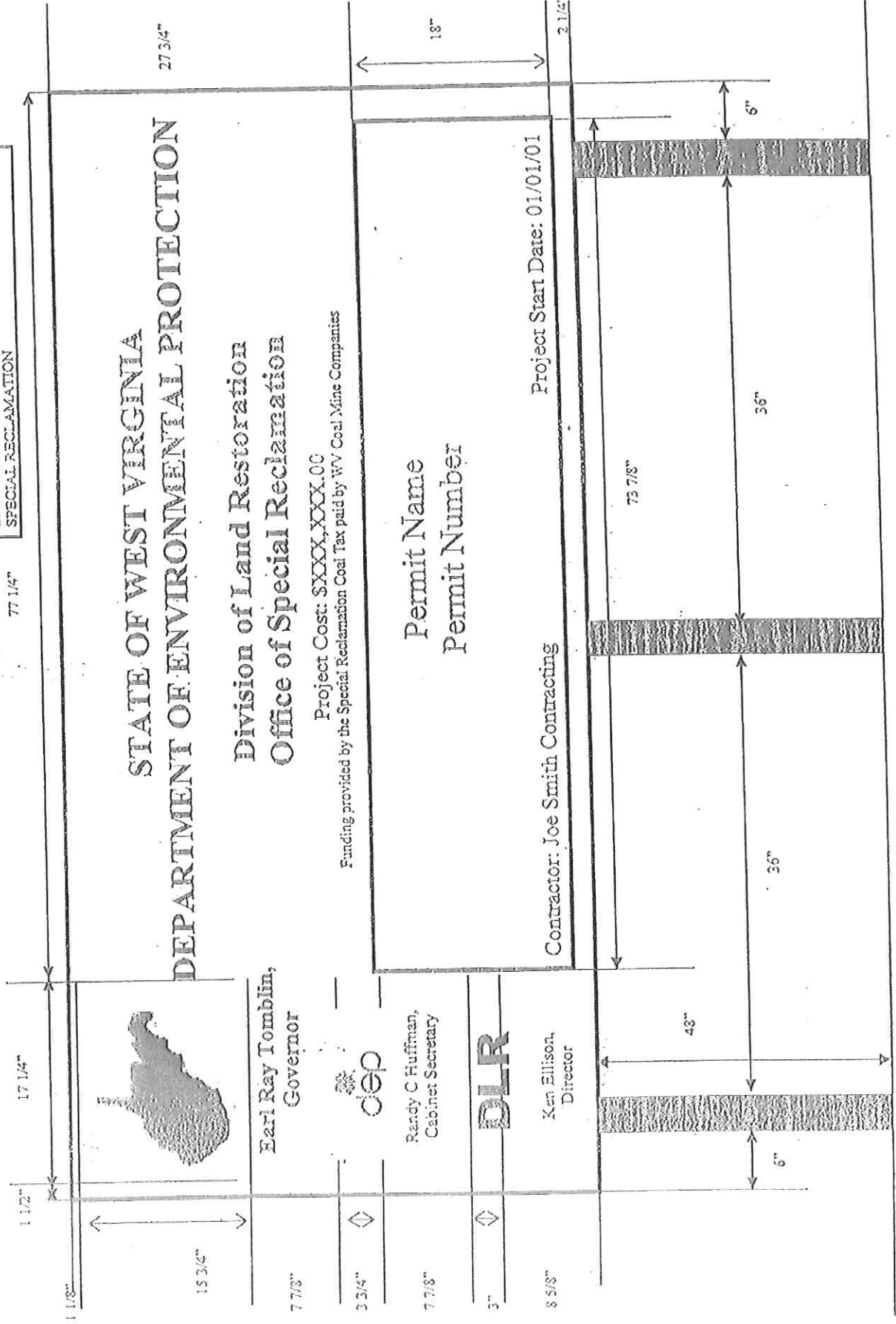

STATE OF WEST VIRGINIA  
 DEPARTMENT OF ENVIRONMENTAL PROTECTION

Division of Land Restoration  
 Office of Special Reclamation

Project Cost: \$XXX,XXX.00  
 Funding provided by the Special Reclamation Coal Tax paid by WV Coal Mine Companies

Earl Ray Tomblin,  
 Governor



Randy C Huffman,  
 Cabinet Secretary



Ken Ellison,  
 Director

Permit Name  
 Permit Number

Contractor: Joe Smith Contracting

Project Start Date: 01/01/01

2 1/4"

17 1/4"

1 1/2"

1 1/8"

27 3/4"

15 3/4"

7 7/8"

3 3/4"

7 7/8"

3"

8 5/8"

18"

73 7/8"

48"

36"

36"

6"

6"

WV-36a STATE OF WEST VIRGINIA  
 REV. 5/26/09 PURCHASING CONTINUATION SHEET  
 VENDOR:

BUYER CB-23	PAGE 25	REQ. OR PO NO. DEP 15573
SPENDING UNIT WEST VIRGINIA DEPARTMENT OF ENVIRONMENTAL PROTECTION/OFFICE OF SPECIAL RECLAMATION		

98"



Earl Ray Tomblin,  
 Governor



Randy C Huffineh,  
 Cabinet Secretary



Ken Ellison,  
 Director

48"

STATE OF WEST VIRGINIA  
 DEPARTMENT OF ENVIRONMENTAL PROTECTION

Division of Land Restoration  
 Office of Special Reclamation

Project Cost: \$XXX,XXX.00  
 Funding provided by the Special Reclamation Coal Tax paid by WV Coal Mine Companies

Permit Name  
 Permit Number

Project Start Date: 01/01/01

Contractor: Joe Smith Contracting

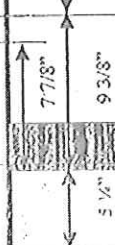

81.38"

WV-36a STATE OF WEST VIRGINIA  
REV. 5/26/09 PURCHASING CONTINUATION SHEET  
VENDOR:

BUYER	PAGE	REQ. OR P.O. NO.
CB-23	26	DEP 15573
SPENDING UNIT		
WEST VIRGINIA DEPARTMENT OF ENVIRONMENTAL PROTECTION/OFFICE OF SPECIAL RECLAMATION		

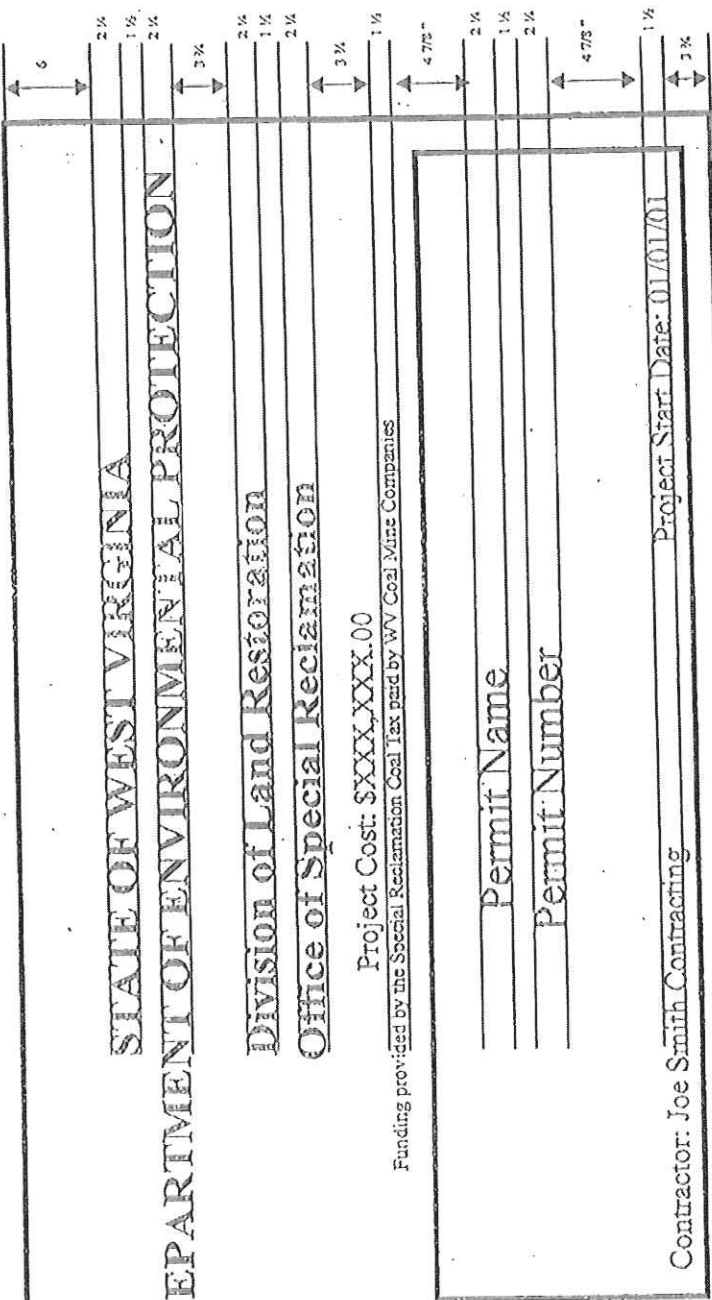

Earl Ray Tomblin,  
Governor



Randy C. Huffman,  
Cabinet Secretary



Ken Eulson,  
Director

WV-36a STATE OF WEST VIRGINIA  
 REV. 5/26/09 PURCHASING CONTINUATION SHEET  
 VENDOR:

BUYER CB-23	PAGE 27	REQ. OR PO NO. DEP 15573
SPENDING UNIT WEST VIRGINIA DEPARTMENT OF ENVIRONMENTAL PROTECTION/OFFICE OF SPECIAL RECLAMATION		

Notes:

1. Sign Board to be 3/4" by 4' X 8' Marine Plywood
2. Sign Board Color is to be White and  
Letter Colors are to be Dark Green
3. 2" X 4" Treated Cross Brace Let into Posts
4. Mount sign to posts using 3/8" X 5" Galvanized Carriage Bolts
5. Posts are to be treated 4" X 4" X 12'
6. Location to be determined by WVDEP

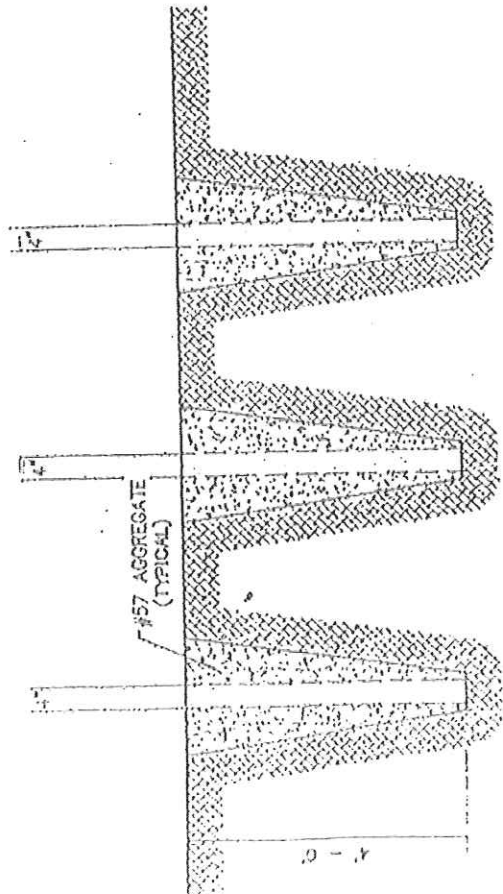
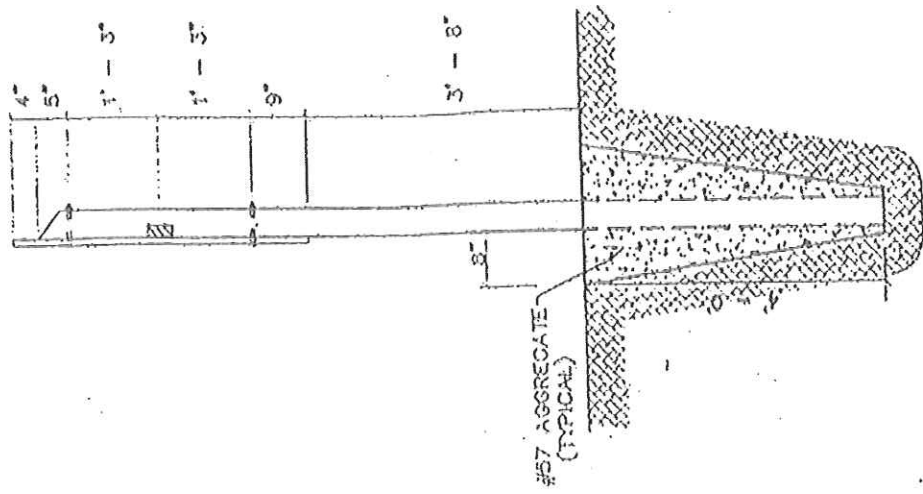

BUYER CB-23	REQ. or P.O. No. DEP15573
SPILL CONTAINMENT	

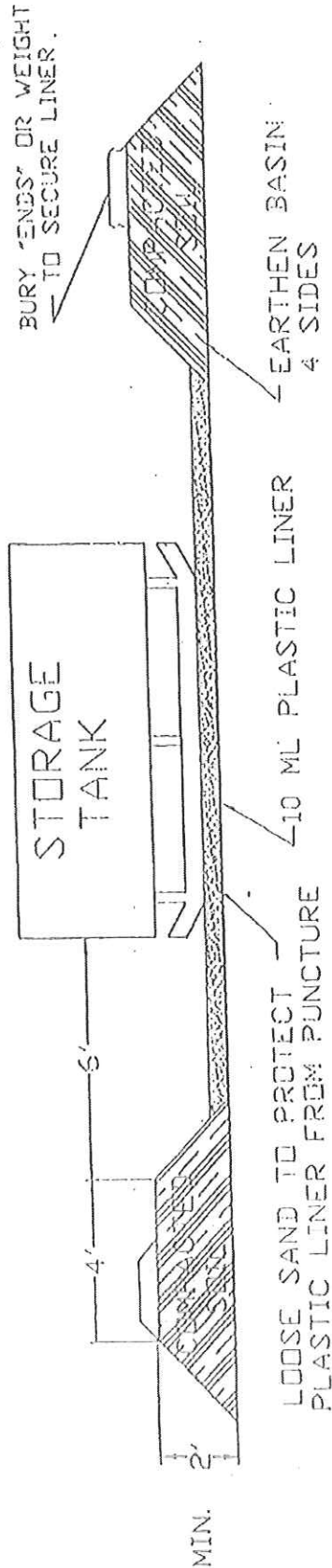

SELECTED HEIGHT OF EARTHEN BERM IS TO BE A TWO (2) FOOT MINIMUM OR ONE HUNDRED TEN PERCENT (110%) OF THE CAPACITY OF THE TANK(S) TOTAL VOLUME WITHIN THE BERM. A SIX (6") INCH FREEBOARD MUST BE INCLUDED.

NOTE: A TWO INCH (2") WATER REMOVAL DRAIN SHALL BE LOCATED AT THE LOWEST POINT IN THE BOTTOM OF THE CONTAINMENT VOLUME. IT SHALL CONNECT TO A NORMALLY CLOSED VALVE OUTSIDE THE DIKE. THE VALVE SHALL BE MANUALLY OPERATED AND PROTECTED FROM UNAUTHORIZED OPERATION. RAINWATER CONTAINED WITHIN THIS DIKE SHALL BE EXAMINED PRIOR TO RELEASE TO ENSURE THAT HARMFUL QUANTITIES OF FUELS AND LUBRICANTS ARE NOT DISCHARGED. ALTERNATE METHODS OF WATER REMOVAL WILL BE CONSIDERED FOR APPROVAL.

TANKS WITH SECONDARY CONTAINMENT MAY BE USED AS AN ALTERNATIVE.



BID BOND PREPARATION INSTRUCTIONS

AGENCY (A)
RFQ/RFP# (B)

Bid Bond

- (A) WV State Agency
(Stated on Page 1 "Spending Unit")
Request for Quotation Number (upper
right corner of page #1)
(C) Your Company Name
(D) City, Location of your Company
(E) State, Location of your Company
(F) Surety Corporate Name
(G) City, Location of Surety
(H) State, Location of Surety
(I) State of Surety Incorporation
(J) City of Surety Incorporation
(K) Minimum amount of acceptable bid
bond is 5% of total bid. You may state
"5% of bid" or a specific amount on
this line in words.
(L) Amount of bond in figures
(M) Brief Description of scope of work
(N) Day of the month
(O) Month
(P) Year
(Q) Name of Corporation
(R) Raised Corporate Seal of Principal
(S) Signature of President or Vice
President
(T) Title of person signing
(U) Raised Corporate Seal of Surety
(V) Corporate Name of Surety
(W) Signature of Attorney in Fact of the
Surety

NOTE: Dated, Power of Attorney with Raised
Surety Seal must accompany this bid
bond.

KNOW ALL MEN BY THESE PRESENTS, That we, the undersigned,
(C) of (D), (E),
as Principal, and (F) of (G),
(H), a corporation organized and existing under the laws
of the State of (I) with its principal office in the City of
(J), as Surety, are held and firmly bound unto The State
of West Virginia, as Obligee, in the penal sum of (K)
(\$ (L)) for the payment of which, well and truly to be made,
we jointly and severally bind ourselves, our heirs, administrators, executors,
successors and assigns.

The Condition of the above obligation is such that whereas the Principal
has submitted to the Purchasing Section of the Department of Administration
a certain bid or proposal, attached hereto and made a part hereof to enter into a
contract in writing for (M)

(M)

NOW THEREFORE.
(a) If said bid shall be rejected, or
(b) If said bid shall be accepted and the Principal shall enter into a
contract in accordance with the bid or proposal attached hereto and shall furnish
any other bonds and insurance required by the bid or proposal, and shall in all
other respects perform the agreement created by the acceptance of said bid then
this obligation shall be null and void, otherwise this obligation shall remain in full
force and effect. It is expressly understood and agreed that the liability of the
Surety for any and all claims hereunder shall, in no event, exceed the penal
amount of this obligation as herein stated

The Surety for value received, hereby stipulates and agrees that the
obligations of said Surety and its bond shall be in no way impaired or affected by
any extension of time within which the Obligee may accept such bid: and said
Surety does hereby waive notice of any such extension.

IN WITNESS WHEREOF, Principal and Surety have hereunto set their
hands and seals, and such of them as are corporations have caused their corporate
seals to be affixed hereto and these presents to be signed by their proper officers,
this (N) day of (O), 20 (P).

Principal Corporate Seal

(R)

(U)
Surety Corporate Seal

(Q)
(Name of Principal)
By (S)
(Must be President or
Vice President)
(T)
Title
(V)
(Name of Surety)
(W)
Attorney-in-Fact

IMPORTANT - Surety executing bonds must be licensed in West Virginia to
transact surety insurance. Raised Corporate Seals must be affixed and a Power of
Attorney must be attached.

**BID BOND**

KNOW ALL MEN BY THESE PRESENTS, That we, the undersigned, Main Street Builders, LLC  
of P.O. Box 309, Princeton, WV 24740, as Principal, and International Fidelity Insurance  
Company of Newark, New Jersey, a corporation organized and existing under the laws of the State of  
New Jersey with its principal office in the City of Newark, as Surety, are held and firmly bound unto the State  
of West Virginia, as Oblige, in the penal sum of five percent of bid (\$ 5%) for the payment of which,  
well and truly to be made, we jointly and severally bind ourselves, our heirs, administrators, executors, successors and assigns.

The Condition of the above obligation is such that whereas the Principal has submitted to the Purchasing Section of the  
Department of Administration a certain bid or proposal, attached hereto and made a part hereof, to enter into a contract in writing for  
reclamation of 6 - acre abandoned mine operation of Royal Scot Minerals, Inc. now under revoked permit number (s) 31 - 72  
near Anjean, Greenbrier County, West Virginia

NOW THEREFORE,

- (a) If said bid shall be rejected, or
- (b) If said bid shall be accepted and the Principal shall enter into a contract in accordance with the bid or proposal attached  
hereto and shall furnish any other bonds and insurance required by the bid or proposal, and shall in all other respects perform the  
agreement created by the acceptance of said bid, then this obligation shall be null and void, otherwise this obligation shall remain in full  
force and effect. It is expressly understood and agreed that the liability of the Surety for any and all claims hereunder shall, in no event,  
exceed the penal amount of this obligation as herein stated.

The Surety, for the value received, hereby stipulates and agrees that the obligations of said Surety and its bond shall be in no  
way impaired or affected by any extension of the time within which the Oblige may accept such bid, and said Surety does hereby  
waive notice of any such extension.

IN WITNESS WHEREOF, Principal and Surety have hereunto set their hands and seals, and such of them as are corporations  
have caused their corporate seals to be affixed hereunto and these presents to be signed by their proper officers, this  
22nd day of September, 2011.

Principal Corporate Seal

Main Street Builders, LLC

(Name of Principal)

By [Signature]

(Must be President or  
Vice President)

Member

(Title)

Surety Corporate Seal

International Fidelity Insurance Company

(Name of Surety)

By [Signature]

Attorney-in-Fact

IMPORTANT - Surety executing bonds must be licensed in West Virginia to transact surety insurance. Corporate seals must be affixed,  
and a power of attorney must be attached.

# POWER OF ATTORNEY INTERNATIONAL FIDELITY INSURANCE COMPANY

HOME OFFICE: ONE NEWARK CENTER, 20TH FLOOR  
NEWARK, NEW JERSEY 07102-5207

## FOR BID BOND/RIDER/CONSENTS/AFFIDAVITS

KNOW ALL MEN BY THESE PRESENTS: That INTERNATIONAL FIDELITY INSURANCE COMPANY, a corporation organized and existing laws of the State of New Jersey, and having its principal office in the City of Newark, New Jersey, does hereby constitute and appoint

C. DAVID THOMAS, RICHARD L. HIGGINBOTHAM, ROSEANN B. DYB-SMALLEY, BUNNIE MARIE PERRINE, JEFFERY O'DELL, ROBIN HUBBARD-SHERROD

Charleston, WV.

Its true and lawful attorney(s)-in-fact to execute, seal and deliver for and on its behalf as surety, any and all bonds and undertakings, contracts of indemnity and other writings obligatory in the nature thereof, which are or may be allowed, required or permitted by law, statute, rule, regulation, contract or otherwise, and the execution of such instrument(s) in pursuance of these presents, shall be as binding upon the said INTERNATIONAL FIDELITY INSURANCE COMPANY, as fully and amply, to all intents and purposes, as if the same had been duly executed and acknowledged by its regularly elected officers at its principal office.

This Power of Attorney is executed, and may be revoked, pursuant to and by authority of Article 3-Section 3, of the By-Laws adopted by the Board of Directors of INTERNATIONAL FIDELITY INSURANCE COMPANY at a meeting called and held on the 7th day of February, 1974.

The President or any Vice President, Executive Vice President, Secretary or Assistant Secretary, shall have power and authority

- (1) To appoint Attorneys-in-fact, and to authorize them to execute on behalf of the Company, and attach the Seal of the Company thereto, bonds and undertakings, contracts of indemnity and other writings obligatory in the nature thereof and,
- (2) To remove, at any time, any such attorney-in-fact and revoke the authority given.

Further, this Power of Attorney is signed and sealed by facsimile pursuant to resolution of the Board of Directors of said Company adopted at a meeting duly called and held on the 29th day of April, 1982 of which the following is a true excerpt:

Now therefore the signatures of such officers and the seal of the Company may be affixed to any such power of attorney or any certificate relating thereto by facsimile, and any such power of attorney or certificate bearing such facsimile signatures or facsimile seal shall be valid and binding upon the Company and any such power so executed and certified by facsimile signatures and facsimile seal shall be valid and binding upon the Company in the future with respect to any bond or undertaking to which it is attached.



IN TESTIMONY WHEREOF, INTERNATIONAL FIDELITY INSURANCE COMPANY has caused this instrument to be signed and its corporate seal to be affixed by its authorized officer, this 16th day of October, A.D. 2007.

INTERNATIONAL FIDELITY INSURANCE COMPANY

STATE OF NEW JERSEY  
County of Essex

*[Handwritten Signature]*  
Secretary

On this 16th day of October 2007, before me came the individual who executed the preceding instrument, to me personally known, and, being by me duly sworn, said he is the therein described and authorized officer of the INTERNATIONAL FIDELITY INSURANCE COMPANY; that the seal affixed to said instrument is the Corporate Seal of said Company; that the said Corporate Seal and his signature were duly affixed by order of the Board of Directors of said Company.



IN TESTIMONY WHEREOF, I have hereunto set my hand affixed my Official Seal, at the City of Newark, New Jersey the day and year first above written.

*[Handwritten Signature]*

A NOTARY PUBLIC OF NEW JERSEY  
My Commission Expires Nov. 21, 2010

### CERTIFICATION

I, the undersigned officer of INTERNATIONAL FIDELITY INSURANCE COMPANY do hereby certify that I have compared the foregoing copy of the Power of Attorney and affidavit, and the copy of the Section of the By-Laws of said Company as set forth in said Power of Attorney, with the ORIGINALS ON IN THE HOME OFFICE OF SAID COMPANY, and that the same are correct transcripts thereof, and of the whole of the said originals, and that the said Power of Attorney has not been revoked and is now in full force and effect

IN TESTIMONY WHEREOF, I have hereunto set my hand this 22nd day of September, 2011

*[Handwritten Signature]*  
Assistant Secretary



State of West Virginia  
 Department of Administration  
 Purchasing Division  
 2019 Washington Street East  
 Post Office Box 50130  
 Charleston, WV 25305-0130

### Request for Quotation

RFQ NUMBER
DEP15573

PAGE
1

ADDRESS CORRESPONDENCE TO ATTENTION OF:
CHUCK BOWMAN 304-558-2157

RFQ COPY  
 TYPE NAME/ADDRESS HERE

VENDOR

**MAIN STREET BUILDERS, LLC**  
 PO Box 309 311 S. Walker Street  
 Princeton, WV 24740  
 WV#035914  
 VA# 2705133610A  
 ph: 304-487-3912 Fax:304-425-2171

SHIP TO

ENVIRONMENTAL PROTECTION  
 DEPT. OF  
 OFFICE OF SPECIAL RECLAMATION  
 116 INDUSTRIAL DRIVE  
 OAK HILL, WV  
 25901 304-465-1911

DATE PRINTED	TERMS OF SALE	SHIP VIA	F.O.B.	FREIGHT TERMS
09/18/2011				

BID OPENING DATE: **09/22/2011** BID OPENING TIME **01:30PM**

LINE	QUANTITY	UOP	CAT. NO.	ITEM NUMBER	UNIT PRICE	AMOUNT
0001	1	JB		962-73		
***** ADDENDUM NO. 1 ***** ADDENDUM ISSUED FOR THE ROYAL SCOT MINERALS PROJECT IN GREENBRIER CO., TO DISTRIBUTE THE PRE-BID SIGN-IN SHEETS AND THE Q/A RESULTING FROM THE MANDATORY PRE-BID MEETING ON 09/14/2011. BID OPENING DATE AND TIME REMAIN UNCHANGED AS 09/22/2011 AT 1:30 PM. ***** NO OTHER CHANGES *****						
RECLAMATION: RESTORATION OF LAND						

SEE REVERSE SIDE FOR TERMS AND CONDITIONS

SIGNATURE <i>J. Adams</i>	TELEPHONE 304-487-3912	DATE 9-22-11
TITLE Member	FEIN 58-2667955	ADDRESS CHANGES TO BE NOTED ABOVE

WHEN RESPONDING TO RFQ, INSERT NAME AND ADDRESS IN SPACE ABOVE LABELED 'VENDOR'

**GENERAL TERMS & CONDITIONS  
REQUEST FOR QUOTATION (RFQ) AND REQUEST FOR PROPOSAL (RFP)**

1. Awards will be made in the best interest of the State of West Virginia.
2. The State may accept or reject in part, or in whole, any bid.
3. All quotations are governed by the *West Virginia Code* and the *Legislative Rules* of the Purchasing Division.
4. Prior to any award, the apparent successful vendor must be properly registered with the Purchasing Division and have paid the required \$125.00 registration fee.
5. All services performed or goods delivered under State Purchase Orders/Contracts are to be continued for the term of the Purchase Order/Contract, contingent upon funds being appropriated by the Legislature or otherwise being made available. In the event funds are not appropriated or otherwise available for these services or goods, this Purchase Order/Contract becomes void and of no effect after June 30.
6. Payment may only be made after the delivery and acceptance of goods or services.
7. Interest may be paid for late payment in accordance with the *West Virginia Code*.
8. Vendor preference will be granted upon written request in accordance with the *West Virginia Code*.
9. The State of West Virginia is exempt from federal and state taxes and will not pay or reimburse such taxes.
10. The Director of Purchasing may cancel any Purchase Order/Contract upon 30 days written notice to the seller.
11. The laws of the State of West Virginia and the *Legislative Rules* of the Purchasing Division shall govern all rights and duties under the Contract, including without limitation the validity of this Purchase Order/Contract.
12. Any reference to automatic renewal is hereby deleted. The Contract may be renewed only upon mutual written agreement of the parties.
13. **BANKRUPTCY:** In the event the vendor/contractor files for bankruptcy protection, this Contract may be deemed null and void, and terminated without further order.
14. **HIPAA Business Associate Addendum** - The West Virginia State Government HIPAA Business Associate Addendum (BAA), approved by the Attorney General, and available online at the Purchasing Division's web site (<http://www.state.wv.us/admin/purchase/vrc/hipaa.htm>) is hereby made part of the agreement. Provided that, the Agency meets the definition of a Covered Entity (45 CFR §160.103) and will be disclosing Protected Health Information (45 CFR §160.103) to the vendor.

---

**INSTRUCTIONS TO BIDDERS**

1. Use the quotation forms provided by the Purchasing Division.
2. **SPECIFICATIONS:** Items offered must be in compliance with the specifications. Any deviation from the specifications must be clearly indicated by the bidder. Alternates offered by the bidder as **EQUAL** to the specifications must be clearly defined. A bidder offering an alternate should attach complete specifications and literature to the bid. The Purchasing Division may waive minor deviations to specifications.
3. Complete all sections of the quotation form.
4. Unit prices shall prevail in cases of discrepancy.
5. All quotations are considered F.O.B. destination unless alternate shipping terms are clearly identified in the quotation.
6. **BID SUBMISSION:** All quotations must be delivered by the bidder to the office listed below prior to the date and time of the bid opening. Failure of the bidder to deliver the quotations on time will result in bid disqualifications.

**SIGNED BID TO:**

Department of Administration  
Purchasing Division  
2019 Washington Street East  
Post Office Box 50130  
Charleston, WV 25305-0130

DEP15573

ROYAL SCOT 31 72 PRE-BID CONFERENCE 09/14/11

Addendum No. 1

CLARIFYING DISCUSSIONS

- 1) Low bidder will be expected to have their bonds submitted within three(3) days of notification.
- 2) Length of performance period shall be ninety (90) days.
- 3) Access through the site shall be maintained at all times to accommodate daily water monitoring by WV DEP personnel and frequent deliveries of water treatment chemicals as necessary.
- 4) The Bucklilly refuse disposal pile shall be regraded and access road to pile shall be reconstructed by mining operator. However maintenance of access road through the entire project shall be the responsibility of the contractor.
- 5) This project is a joint reclamation effort between the Office of Special Reclamation and the mining operator. Therefore a notice to proceed cannot be issued until site preparation for sludge disposal is completed by the mining operator.

QUESTIONS AND ANSWERS (Asked at Pre-Bid)

Question 1) Where are the ponds that we need to pump to in order to dewater the pond?

Answer: The treatment ponds are located in the next hollow. Water will be directed to the "reddish" pond.

Question 2) Do we pump water down the ditch line?

Answer: Yes. Pump into the ditch line.

Question 3) If Site B is needed, whose responsibility is it for the preparation of the sludge storage areas?

Answer: If Site B is needed, it will be the mining operator's responsibility to prepare the sludge storage areas.

Question 4) If we run out of room here (Site A), how long will we have to sit before Site B is ready to use?

Answer: Hopefully we will have enough heads up to see if you run out of room or not so that contractor is not held up.

Question 5) Could you elaborate more on how you arrived at the yardage you projected would come out of this pond?

Answer: The mining operator dug test pits in the Intersection Pond to come up with a rough yardage. Our estimate was based on the deepest point, about 25 feet.

### QUESTIONS AND ANSWERS (Received 09-15-11)

Question 1) Reference is made that the "Contractor shall survey cross-sections and/or profiles in areas of on-site and off-site excavation areas". I am aware of the on-site excavation area but where is the off-site excavation area?

Answer: There is no off-site excavation that the contractor is responsible for.

Question 2) Concerning cross-sections: What intervals are required for the baseline stations and shots along the cross-sections?

Answer: Fifty (50) foot stations and fifty (50) foot along cross-sections.

Question 3) Has a baseline been established on site?

Answer: No.

Question 4) Is the horizontal and vertical control provided on site?

Answer: No, contractor shall be responsible for establishing vertical and horizontal control. A minimum of two (2) reference points shall be located in areas that are outside of possible disturbed areas.

Question 5) What are the horizontal and vertical datum's required for this project?

Answer: NAD 27 or NAD 83

SIGN IN SHEET

Request for Proposal No. DEP15573

ROYAL SCOT MINERALS, INC. (31-72)

\* PLEASE BE SURE TO PRINT LEGIBLY - IF POSSIBLE, LEAVE A BUSINESS CARD

Date: Sept. 14, 2011

TELEPHONE & FAX NUMBERS

FIRM & REPRESENTATIVE NAME MAILING ADDRESS

FIRM & REPRESENTATIVE NAME	MAILING ADDRESS	PHONE TOLL FREE	FAX
Company: <u>Eastern Arrow</u>		PHONE <u>304 414 0255</u>	
Rep: <u>Tom R Handley</u>		TOLL FREE	
Email Address: <u>Charleston WV</u>		FAX	
Company: <u>Aspen Corporation</u>	<u>2400 Rafter Dr Daniels</u>	PHONE <u>304-263-4573</u>	
Rep: <u>Joe Kubin</u>	<u>WV 25832</u>	TOLL FREE	
Email Address: <u>jkubin@aspen-golf.com</u>		FAX	
Company: <u>RBS, INC</u>	<u>PO BOX 198</u>	PHONE <u>304-497-3800</u>	
Rep: <u>JK ROSE</u>	<u>MAXWELLTON, WV</u>	TOLL FREE	
Email Address: <u>WVIRONCONCRETE@FRONTIER.NET</u>	<u>24957</u>	FAX <u>304-497-3802</u>	
Company: <u>DCI SHIELDS INC</u>	<u>PO Box 1259</u>	PHONE <u>304323 1996</u>	
Rep: <u>Michael Gates</u>	<u>Buckhatch WV</u>	TOLL FREE	
Email Address: <u>Robert.Deeb@dcishields.com</u>	<u>24701</u>	FAX <u>304 323 3037</u>	
Company: <u>Piedmont Paving &amp; Exp. Inc</u>	<u>Box 1290</u>	PHONE <u>304 732-8503</u>	
Rep: <u>MIKE BRADFORD</u>	<u>Pineville WV. 24874</u>	TOLL FREE	
Email Address: <u>Tomj PPI@AOT.COM</u>		FAX <u>304 732 7855</u>	



# CONTRACTOR LICENSE

Authorized by the  
**West Virginia Contractor Licensing Board**

**Number:** WV035914

**Classification:**  
GENERAL BUILDING

MAIN STREET BUILDERS LLC  
DBA MAIN STREET BUILDERS LLC  
PO BOX 309  
PRINCETON, WV 24740-0309

**Date Issued**  
AUGUST 07, 2011

**Expiration Date**  
AUGUST 07, 2012

  
Authorized Company Signature

  
Chair, West Virginia Contractor  
Licensing Board



**WEST VIRGINIA  
CONTRACTOR  
LICENSING  
BOARD**

This license, or a copy thereof, must be posted in a conspicuous place at every construction site where work is being performed. This license number must appear in all advertisements, on all bid submissions and on all fully executed and binding contracts. This license cannot be assigned or transferred by licensee. Issued under provisions of West Virginia Code, Chapter 21, Article 11.



# CERTIFICATE OF LIABILITY INSURANCE

OP ID: RD

DATE (MM/DD/YYYY)

07/18/11

THIS CERTIFICATE IS ISSUED AS A MATTER OF INFORMATION ONLY AND CONFERS NO RIGHTS UPON THE CERTIFICATE HOLDER. THIS CERTIFICATE DOES NOT AFFIRMATIVELY OR NEGATIVELY AMEND, EXTEND OR ALTER THE COVERAGE AFFORDED BY THE POLICIES BELOW. THIS CERTIFICATE OF INSURANCE DOES NOT CONSTITUTE A CONTRACT BETWEEN THE ISSUING INSURER(S), AUTHORIZED REPRESENTATIVE OR PRODUCER, AND THE CERTIFICATE HOLDER.

IMPORTANT: If the certificate holder is an ADDITIONAL INSURED, the policy(ies) must be endorsed. If SUBROGATION IS WAIVED, subject to the terms and conditions of the policy, certain policies may require an endorsement. A statement on this certificate does not confer rights to the certificate holder in lieu of such endorsement(s).

PRODUCER George H. Friedlander Co. PO Box 2466 1566 Kanawha Blvd. E. Charleston, WV 25311	304-357-4520	CONTACT NAME:	
	304-345-8724	PHONE (A/C, No, Ext): 304-357-4520	FAX (A/C, No): 304-345-8724
		E-MAIL ADDRESS:	
		PRODUCER CUSTOMER ID #: MAIS001	
INSURER(S) AFFORDING COVERAGE			NAIC #
INSURED Main Street Builders, LLC P.O. Box 309 Princeton, WV 24740	INSURER A: Westfield Insurance Companies		24112
	INSURER B: BrickStreet Insurance		
	INSURER C:		
	INSURER D:		
	INSURER E:		
	INSURER F:		

COVERAGES CERTIFICATE NUMBER: REVISION NUMBER:

THIS IS TO CERTIFY THAT THE POLICIES OF INSURANCE LISTED BELOW HAVE BEEN ISSUED TO THE INSURED NAMED ABOVE FOR THE POLICY PERIOD INDICATED. NOTWITHSTANDING ANY REQUIREMENT, TERM OR CONDITION OF ANY CONTRACT OR OTHER DOCUMENT WITH RESPECT TO WHICH THIS CERTIFICATE MAY BE ISSUED OR MAY PERTAIN, THE INSURANCE AFFORDED BY THE POLICIES DESCRIBED HEREIN IS SUBJECT TO ALL THE TERMS, EXCLUSIONS AND CONDITIONS OF SUCH POLICIES. LIMITS SHOWN MAY HAVE BEEN REDUCED BY PAID CLAIMS.

INSR LTR	TYPE OF INSURANCE	ADDL INSR	SUBR WVD	POLICY NUMBER	POLICY EFF (MM/DD/YYYY)	POLICY EXP (MM/DD/YYYY)	LIMITS
A	GENERAL LIABILITY			TRA5270200	05/26/11	05/26/12	EACH OCCURRENCE \$ 1,000,000
	<input checked="" type="checkbox"/> COMMERCIAL GENERAL LIABILITY						DAMAGE TO RENTED PREMISES (Ea occurrence) \$ 300,000
	<input type="checkbox"/> CLAIMS-MADE <input checked="" type="checkbox"/> OCCUR						MED EXP (Any one person) \$ 10,000
							PERSONAL & ADV INJURY \$ 1,000,000
							GENERAL AGGREGATE \$ 2,000,000
	GEN'L AGGREGATE LIMIT APPLIES PER:						PRODUCTS - COMP/OP AGG \$ 2,000,000
	<input type="checkbox"/> POLICY <input checked="" type="checkbox"/> PROJECT <input type="checkbox"/> LOC						\$
A	AUTOMOBILE LIABILITY			TRA5270200	05/26/11	05/26/12	COMBINED SINGLE LIMIT (Ea accident) \$ 1,000,000
	<input checked="" type="checkbox"/> ANY AUTO						BODILY INJURY (Per person) \$
	<input type="checkbox"/> ALL OWNED AUTOS						BODILY INJURY (Per accident) \$
	<input type="checkbox"/> SCHEDULED AUTOS						PROPERTY DAMAGE (Per accident) \$
	<input checked="" type="checkbox"/> HIRED AUTOS						\$
	<input checked="" type="checkbox"/> NON-OWNED AUTOS						\$
A	UMBRELLA LIAB			TRA5270200	05/26/11	05/26/12	EACH OCCURRENCE \$ 5,000,000
	<input checked="" type="checkbox"/> EXCESS LIAB						AGGREGATE \$ 5,000,000
	<input type="checkbox"/> CLAIMS-MADE						\$
	DEDUCTIBLE						\$
	<input checked="" type="checkbox"/> RETENTION \$ NONE						\$
B	WORKERS COMPENSATION AND EMPLOYERS' LIABILITY			WC10026850-08 WV STATE CODE 23-4-2	05/26/11	05/26/12	<input checked="" type="checkbox"/> WC STATUTORY LIMITS <input type="checkbox"/> OTHER
	ANY PROPRIETOR/PARTNER/EXECUTIVE OFFICER/MEMBER EXCLUDED? (Mandatory in NH)	<input type="checkbox"/> Y <input type="checkbox"/> N	N/A				E.L. EACH ACCIDENT \$ 1,000,000
	If yes, describe under DESCRIPTION OF OPERATIONS below						E.L. DISEASE - EA EMPLOYEE \$ 1,000,000
							E.L. DISEASE - POLICY LIMIT \$ 1,000,000

DESCRIPTION OF OPERATIONS / LOCATIONS / VEHICLES (Attach ACORD 101, Additional Remarks Schedule, if more space is required)  
Evidence of Insurance

CERTIFICATE HOLDER  TO WHOM IT MAY CONCERN	CANCELLATION BLANK01 SHOULD ANY OF THE ABOVE DESCRIBED POLICIES BE CANCELLED BEFORE THE EXPIRATION DATE THEREOF, NOTICE WILL BE DELIVERED IN ACCORDANCE WITH THE POLICY PROVISIONS.
	AUTHORIZED REPRESENTATIVE 

© 1988-2009 ACORD CORPORATION. All rights reserved.

**WEST VIRGINIA  
STATE TAX DEPARTMENT  
BUSINESS REGISTRATION  
CERTIFICATE**

ISSUED TO:  
**MAIN STREET BUILDERS LLC  
311 S WALKER ST  
PRINCETON, WV 24740-2756**

**BUSINESS REGISTRATION ACCOUNT NUMBER: 1049-3747**

This certificate is issued on: 03/17/2010

*This certificate is issued by  
the West Virginia State Tax Commissioner  
in accordance with Chapter 11, Article 12, of the West Virginia Code*

*The person or organization identified on this certificate is registered  
to conduct business in the State of West Virginia at the location above.*

*This certificate is not transferrable and must be displayed at the location for which it is issued.  
This certificate shall be permanent until cessation of the business for which the certificate of registration  
was granted or until it is suspended, revoked or cancelled by the Tax Commissioner.*

*Change in name or change of location shall be considered a cessation of the business and a new  
certificate shall be required.*

*TRAVELING/STREET VENDORS: Must carry a copy of this certificate in every vehicle operated by them.  
CONTRACTORS, DRILLING OPERATORS, TIMBER/LOGGING OPERATIONS: Must have a copy of  
this certificate displayed at every job site within West Virginia.*



State of West Virginia  
DRUG FREE WORKPLACE CONFORMANCE AFFIDAVIT  
West Virginia Code §21-1D-5

STATE OF WEST VIRGINIA

COUNTY OF MERCER, TO-WIT:

I, M. ADAM SARVER, after being first duly sworn, depose and state as follows:

- 1. I am an employee of MAIN STREET BUILDERS, LLC; and,  
(Company Name)
- 2. I do hereby attest that MAIN STREET BUILDERS, LLC  
(Company Name)

maintains a valid written drug free workplace policy and that such policy is in compliance with **West Virginia Code §21-1D-5**.

The above statements are sworn to under the penalty of perjury.

MAIN STREET BUILDERS, LLC  
(Company Name)

By: [Signature]

Title: MEMBER

Date: 9-22-11

Taken, subscribed and sworn to before me this 22nd day of September 2011.

By Commission expires April 22, 2018

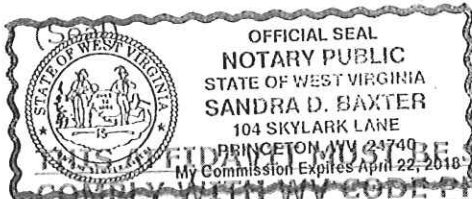

[Signature]  
(Notary Public)

**AFFIDAVIT MUST BE SUBMITTED WITH THE BID IN ORDER TO COMPLY WITH WV CODE PROVISIONS. FAILURE TO INCLUDE THE AFFIDAVIT WITH THE BID SHALL RESULT IN DISQUALIFICATION OF THE BID.**

RFQ No. DEP15573

STATE OF WEST VIRGINIA  
Purchasing Division

**PURCHASING AFFIDAVIT**

West Virginia Code §5A-3-10a states: No contract or renewal of any contract may be awarded by the state or any of its political subdivisions to any vendor or prospective vendor when the vendor or prospective vendor or a related party to the vendor or prospective vendor is a debtor and the debt owned is an amount greater than one thousand dollars in the aggregate

**DEFINITIONS:**

"Debt" means any assessment, premium, penalty, fine, tax or other amount of money owed to the state or any of its political subdivisions because of a judgment, fine, permit violation, license assessment, defaulted workers' compensation premium, penalty or other assessment presently delinquent or due and required to be paid to the state or any of its political subdivisions, including any interest or additional penalties accrued thereon.

"Debtor" means any individual, corporation, partnership, association, Limited Liability Company or any other form or business association owing a debt to the state or any of its political subdivisions. "Political subdivision" means any county commission; municipality; county board of education; any instrumentality established by a county or municipality; any separate corporation or instrumentality established by one or more counties or municipalities, as permitted by law; or any public body charged by law with the performance of a government function or whose jurisdiction is coextensive with one or more counties or municipalities. "Related party" means a party, whether an individual, corporation, partnership, association, limited liability company or any other form or business association or other entity whatsoever, related to any vendor by blood, marriage, ownership or contract through which the party has a relationship of ownership or other interest with the vendor so that the party will actually or by effect receive or control a portion of the benefit, profit or other consideration from performance of a vendor contract with the party receiving an amount that meets or exceeds five percent of the total contract amount.

**EXCEPTION:** The prohibition of this section does not apply where a vendor has contested any tax administered pursuant to chapter eleven of this code, workers' compensation premium, permit fee or environmental fee or assessment and the matter has not become final or where the vendor has entered into a payment plan or agreement and the vendor is not in default of any of the provisions of such plan or agreement.

Under penalty of law for false swearing (*West Virginia Code §61-5-3*), it is hereby certified that the vendor affirms and acknowledges the information in this affidavit and is in compliance with the requirements as stated.

**WITNESS THE FOLLOWING SIGNATURE**

Vendor's Name: MAIN STREET BUILDERS, LLC

Authorized Signature: [Signature] Date: 9-22-11

State of West Virginia

County of Mercer, to-wit:

Taken, subscribed, and sworn to before me this 22<sup>nd</sup> day of September, 2011.

My Commission expires April 22, 2018.

AFFIX SEAL HERE

NOTARY PUBLIC [Signature: Sandra D. Baxter]

