



State of West Virginia
 Department of Administration
 Purchasing Division
 2019 Washington Street East
 Post Office Box 50130
 Charleston, WV 25305-0130

Request for Quotation

RFQ NUMBER
 BVH391

PAGE
 1

ADDRESS CORRESPONDENCE TO ATTENTION OF:
 TARA LYLE
 804-558-2544

VENDOR

*A17110959 800-346-9464
 INDEPENDENT HARDWARE INC
 14 S FRONT STREET
 PHILADELPHIA PA 19106

SHIP TO

WEST VIRGINIA VETERANS HOME
 512 WATER STREET
 BARBOURSVILLE, WV
 25504 736-1027

DATE PRINTED	TERMS OF SALE	SHIP VIA	F.O.B.	FREIGHT TERMS
09/19/2011				

BID OPENING DATE: 10/05/2011 BID OPENING TIME 01:30PM

LINE	QUANTITY	UOP	CAT. NO.	ITEM NUMBER	UNIT PRICE	AMOUNT
ADDENDUM NO. 1						
1. QUESTIONS AND ANSWERS ARE ATTACHED. 2. PRE-BID SIGN-IN SHEET ATTACHED. 3. ADDENDUM ACKNOWLEDGEMENT IS ATTACHED. THIS DOCUMENT SHOULD BE SIGNED AND RETURNED WITH YOUR BID. FAILURE TO SIGN AND RETURN MAY RESULT IN DISQUALIFICATION OF YOUR BID.						
END OF ADDENDUM NO. 1						
0001	1	JB		450-55		
LOCKS AND LOCK SETS						
***** THIS IS THE END OF RFQ BVH391 ***** TOTAL: _____						

RECEIVED
 2011 OCT -5 AM 10:24
 WV PURCHASING DIVISION

SEE REVERSE SIDE FOR TERMS AND CONDITIONS

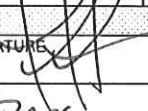
SIGNATURE:  TELEPHONE: _____ DATE: 10/4/11

TITLE: Pres. [REDACTED] ADDRESS CHANGES TO BE NOTED ABOVE

WHEN RESPONDING TO RFQ, INSERT NAME AND ADDRESS IN SPACE ABOVE LABELED 'VENDOR'

GENERAL TERMS & CONDITIONS REQUEST FOR QUOTATION (RFQ) AND REQUEST FOR PROPOSAL (RFP)

1. Awards will be made in the best interest of the State of West Virginia.
2. The State may accept or reject in part, or in whole, any bid.
3. Prior to any award, the apparent successful vendor must be properly registered with the Purchasing Division and have paid the required \$125 fee.
4. All services performed or goods delivered under State Purchase Order/Contracts are to be continued for the term of the Purchase Order/Contracts, contingent upon funds being appropriated by the Legislature or otherwise being made available. In the event funds are not appropriated or otherwise available for these services or goods this Purchase Order/Contract becomes void and of no effect after June 30.
5. Payment may only be made after the delivery and acceptance of goods or services.
6. Interest may be paid for late payment in accordance with the *West Virginia Code*.
7. Vendor preference will be granted upon written request in accordance with the *West Virginia Code*.
8. The State of West Virginia is exempt from federal and state taxes and will not pay or reimburse such taxes.
9. The Director of Purchasing may cancel any Purchase Order/Contract upon 30 days written notice to the seller.
10. The laws of the State of West Virginia and the *Legislative Rules* of the Purchasing Division shall govern the purchasing process.
11. Any reference to automatic renewal is hereby deleted. The Contract may be renewed only upon mutual written agreement of the parties.
12. **BANKRUPTCY:** In the event the vendor/contractor files for bankruptcy protection, the State may deem this contract null and void, and terminate such contract without further order.
13. **HIPAA BUSINESS ASSOCIATE ADDENDUM:** The West Virginia State Government HIPAA Business Associate Addendum (BAA), approved by the Attorney General, is available online at www.state.wv.us/admin/purchase/vrc/hipaa.htm and is hereby made part of the agreement. Provided that the Agency meets the definition of a Cover Entity (45 CFR §160.103) and will be disclosing Protected Health Information (45 CFR §160.103) to the vendor.
14. **CONFIDENTIALITY:** The vendor agrees that he or she will not disclose to anyone, directly or indirectly, any such personally identifiable information or other confidential information gained from the agency, unless the individual who is the subject of the information consents to the disclosure in writing or the disclosure is made pursuant to the agency's policies, procedures, and rules. Vendor further agrees to comply with the Confidentiality Policies and Information Security Accountability Requirements, set forth in <http://www.state.wv.us/admin/purchase/privacy/noticeConfidentiality.pdf>.
15. **LICENSING:** Vendors must be licensed and in good standing in accordance with any and all state and local laws and requirements by any state or local agency of West Virginia, including, but not limited to, the West Virginia Secretary of State's Office, the West Virginia Tax Department, and the West Virginia Insurance Commission. The vendor must provide all necessary releases to obtain information to enable the director or spending unit to verify that the vendor is licensed and in good standing with the above entities.
16. **ANTITRUST:** In submitting a bid to any agency for the State of West Virginia, the bidder offers and agrees that if the bid is accepted the bidder will convey, sell, assign or transfer to the State of West Virginia all rights, title and interest in and to all causes of action it may now or hereafter acquire under the antitrust laws of the United States and the State of West Virginia for price fixing and/or unreasonable restraints of trade relating to the particular commodities or services purchased or acquired by the State of West Virginia. Such assignment shall be made and become effective at the time the purchasing agency tenders the initial payment to the bidder.

I certify that this bid is made without prior understanding, agreement, or connection with any corporation, firm, limited liability company, partnership, or person or entity submitting a bid for the same material, supplies, equipment or services and is in all respects fair and without collusion or fraud. I further certify that I am authorized to sign the certification on behalf of the bidder or this bid.

INSTRUCTIONS TO BIDDERS

1. Use the quotation forms provided by the Purchasing Division. Complete all sections of the quotation form.
2. Items offered must be in compliance with the specifications. Any deviation from the specifications must be clearly indicated by the bidder. Alternates offered by the bidder as **EQUAL** to the specifications must be clearly defined. A bidder offering an alternate should attach complete specifications and literature to the bid. The Purchasing Division may waive minor deviations to specifications.
3. Unit prices shall prevail in case of discrepancy. All quotations are considered F.O.B. destination unless alternate shipping terms are clearly identified in the quotation.
4. All quotations must be delivered by the bidder to the office listed below prior to the date and time of the bid opening. Failure of the bidder to deliver the quotations on time will result in bid disqualifications: Department of Administration, Purchasing Division, 2019 Washington Street East, P.O. Box 50130, Charleston, WV 25305-0130
5. Communication during the solicitation, bid, evaluation or award periods, except through the Purchasing Division, is strictly prohibited (W.Va. C.S.R. §148-1-6.6).

BVH391
ADDENDUM NO. 1

Q1: What type of Grade 1 hardware do you mean? For instance there is lower grade 1 like US Lock, Falcon, Hager and Dorma. Then there is top of the line like Schlage.

A1: The specifications state Grade 1, of a current production, with available repair or replacement parts for at least a (3) three year period after the date of installation. That is all we are requiring. Our main concern is the availability of replacement parts the lower or higher end of Grade 1 is not a factor.

Q2: What is meant by certified locksmith? We have carpenters that do this type of work all the time.

A2: As per our specifications, a certified locksmith is a member of the Associated Locksmith of America or an equally accredited organization. Must be someone with the certified knowledge of locks and the internal workings of those locks and locksets.

Q3: We have one supplier that is certified by Ingersoll Rand Company, would this be OK?

A3: If the supplier is also going to be the installer or supervise the work, then yes. If not, then no.

Q4: Would the carpenters union be considered as an equally accredited organization?

A4: No.

Q5: Bid item #8 – are these doors all rated one-hour?

A5: All doors are a minimum one-hour. Not sure how this relates to the locks.

The bid opening is scheduled for 10/05/2011 at 1:30 pm.

No additional questions will be accepted on this RFQ.

SIGN IN SHEET

Request for Proposal No. BVN391

PLEASE PRINT

Date: 9/13/11

* PLEASE BE SURE TO PRINT LEGIBLY - IF POSSIBLE, LEAVE A BUSINESS CARD

FIRM & REPRESENTATIVE NAME	MAILING ADDRESS	TELEPHONE & FAX NUMBERS
Company: <u>Architectural Interior Products Inc.</u> Rep: <u>Jeff Starcher</u> Email Address: <u>jeff@aipinc.biz</u>	<u>2908 Charles Avenue</u> <u>Dunbar, WV 25064</u>	PHONE <u>(304) 766-2211 x315</u> TOLL FREE FAX <u>(304) 766-2214</u>
Company: <u>Independent Hardware</u> Rep: <u>FRANK STANCO</u> Email Address: <u>F.Stanco@IndependentHardware.com</u>	<u>145. Frank St.</u> <u>Plata Pa</u>	PHONE <u>1-800-346-9464</u> TOLL FREE <u>1-800-346-9464</u> FAX <u>215-922-6552</u>
Company: <u>Stotts Property Management LLC</u> Rep: <u>Glenn Stotts</u> Email Address: <u>Glennstotts@gmail.com</u>	<u>3003 Stanton Rd</u> <u>Huntington WV 25702</u>	PHONE <u>304 360 0181</u> TOLL FREE FAX <u>(304) 522-4817</u>
Company: <u>CAMEL Technologies</u> Rep: <u>Ronny Lilly</u> Email Address: <u>ronny1@cameltechnologies.com</u>	<u>1726 Ohio Ave</u> <u>Dunbar WV 25064</u>	PHONE <u>304 776 8063</u> TOLL FREE FAX <u>304 776 8095</u>
Company: <u>Hager Construction, LLC</u> Rep: <u>Phillip Wiseman</u> Email Address: <u>phillip.wiseman@comcast.net</u>	<u>5192 Brady Road</u> <u>Huntington, WV 25705</u>	PHONE <u>304-302-7885</u> TOLL FREE <u>Ext. 15 - 7885</u> FAX <u>304-302-7895</u>

EXHIBIT 10

REQUISITION NO.:

ADDENDUM ACKNOWLEDGEMENT

I HEREBY ACKNOWLEDGE RECEIPT OF THE FOLLOWING CHECKED
ADDENDUM(S) AND HAVE MADE THE NECESSARY REVISIONS TO MY
PROPOSAL, PLANS AND/OR SPECIFICATION, ETC.

ADDENDUM NO.'S:

NO. 1 

NO. 2

NO. 3

NO. 4

NO. 5

I UNDERSTAND THAT FAILURE TO CONFIRM THE RECEIPT OF THE
ADDENDUM(S) MAY BE CAUSE FOR REJECTION OF BIDS. VENDOR
MUST CLEARLY UNDERSTAND THAT ANY VERBAL
REPRESENTATION MADE OR ASSUMED TO BE MADE DURING ANY
ORAL DISCUSSION HELD BETWEEN VENDOR'S REPRESENTATIVES
AND ANY STATE PERSONNEL IS NOT BINDING. ONLY THE
INFORMATION ISSUED IN WRITING AND ADDED TO THE
SPECIFICATIONS BY AN OFFICIAL ADDENDUM IS BINDING.

.....
INDEPENDENT HARDWARE INC.
SIGNATURE
INDEPENDENT HARDWARE INC.

.....
COMPANY

10/4/11
.....
DATE



State of West Virginia
 Department of Administration
 Purchasing Division
 2019 Washington Street East
 Post Office Box 50130
 Charleston, WV 25305-0130

Request for Quotation

RFQ NUMBER
BVH391

PAGE
2

ADDRESS CORRESPONDENCE TO ATTENTION OF:
TARA LYLE
304-558-2544

RFQ COPY
 TYPE NAME/ADDRESS HERE

VENDOR

WEST VIRGINIA VETERANS HOME

SHIP TO

512 WATER STREET
 BARBOURSVILLE, WV
 25504 736-1027

DATE PRINTED	TERMS OF SALE	SHIP VIA	F.O.B.	FREIGHT TERMS
08/31/2011				

BID OPENING DATE: 10/05/2011 BID OPENING TIME 01:30PM

LINE	QUANTITY	UOP	CAT. NO.	ITEM NUMBER	UNIT PRICE	AMOUNT
<p>REPRESENT MORE THAN ONE BIDDER.</p> <p>AN ATTENDANCE SHEET WILL BE MADE AVAILABLE FOR ALL POTENTIAL BIDDERS TO COMPLETE. THIS WILL SERVE AS THE OFFICIAL DOCUMENT VERIFYING ATTENDANCE AT THE MANDATORY PRE-BID. FAILURE TO PROVIDE YOUR COMPANY AND REPRESENTATIVE NAME ON THE ATTENDANCE SHEET WILL RESULT IN DISQUALIFICATION OF THE BID. THE STATE WILL NOT ACCEPT ANY OTHER DOCUMENTATION TO VERIFY ATTENDANCE. THE BIDDER IS RESPONSIBLE FOR ENSURING THEY HAVE COMPLETED THE INFORMATION REQUIRED ON THE ATTENDANCE SHEET. THE PURCHASING DIVISION AND THE STATE AGENCY WILL NOT ASSUME ANY RESPONSIBILITY FOR A BIDDER-S FAILURE TO COMPLETE THE PRE-BID ATTENDANCE SHEET. IN ADDITION, WE REQUEST THAT ALL POTENTIAL BIDDERS INCLUDE THEIR E-MAIL ADDRESS AND FAX NUMBER.</p> <p>ALL POTENTIAL BIDDERS ARE REQUESTED TO ARRIVE PRIOR TO THE STARTING TIME FOR THE PRE-BID. BIDDERS WHO ARRIVE LATE, BUT PRIOR TO THE DISMISSAL OF THE TECHNICAL PORTION OF THE PRE-BID WILL BE PERMITTED TO SIGN IN. BIDDERS WHO ARRIVE AFTER CONCLUSION OF THE TECHNICAL PORTION OF THE PRE-BID, BUT DURING ANY SUBSEQUENT PART OF THE PRE-BID WILL NOT BE PERMITTED TO SIGN THE ATTENDANCE SHEET.</p> <p>INQUIRIES:</p> <p>WRITTEN QUESTIONS WILL BE ACCEPTED UNTIL CLOSE OF BUSINESS ON 09/19/2011. QUESTIONS MAY BE SENT VIA USPS, FAX, COURIER OR E-MAIL. IN ORDER TO ASSURE NO VENDOR RECEIVES AN UNFAIR ADVANTAGE, NO SUBSTANTIVE QUESTIONS WILL BE ANSWERED ORALLY. IF POSSIBLE, E-MAIL QUESTIONS ARE PREFERRED. ADDRESS INQUIRIES TO:</p> <p>TARA LYLE</p>						

SEE REVERSE SIDE FOR TERMS AND CONDITIONS

SIGNATURE	TELEPHONE	DATE 10/4/11
TITLE President	FEIN	ADDRESS CHANGES TO BE NOTED ABOVE

WHEN RESPONDING TO RFQ, INSERT NAME AND ADDRESS IN SPACE ABOVE LABELED 'VENDOR'



State of West Virginia
 Department of Administration
 Purchasing Division
 2019 Washington Street East
 Post Office Box 50130
 Charleston, WV 25305-0130

Request for Quotation

RFQ NUMBER
BVH391

PAGE
3

ADDRESS CORRESPONDENCE TO ATTENTION OF:
TARA LYLE 304-558-2544

RFQ COPY
 TYPE NAME/ADDRESS HERE

VENDOR

SHIP TO

WEST VIRGINIA VETERANS HOME

 512 WATER STREET
 BARBOURSVILLE, WV
 25504 736-1027

DATE PRINTED	TERMS OF SALE	SHIP VIA	F.O.B.	FREIGHT TERMS
08/31/2011				

BID OPENING DATE: 10/05/2011 BID OPENING TIME 01:30PM

LINE	QUANTITY	UOP	CAT NO	ITEM NUMBER	UNIT PRICE	AMOUNT
DEPARTMENT OF ADMINISTRATION PURCHASING DIVISION 2019 WASHINGTON STREET, EAST CHARLESTON, WV 25305 FAX: 304-558-4115 EMAIL: TARA.L.LYLE@WV.GOV THE MODEL/BRAND/SPECIFICATIONS NAMED HEREIN ESTABLISH THE ACCEPTABLE LEVEL OF QUALITY ONLY AND ARE NOT INTENDED TO REFLECT A PREFERENCE OR FAVOR ANY PARTICULAR BRAND OR VENDOR. VENDORS WHO ARE BIDDING ALTERNATES SHOULD SO STATE AND INCLUDE PERTINENT LITERATURE AND SPECIFICATIONS. FAILURE TO PROVIDE INFORMATION FOR ANY ALTERNATES MAY BE GROUNDS FOR REJECTION OF THE BID. THE STATE RESERVES THE RIGHT TO WAIVE MINOR IRREGULARITIES IN BIDS OR SPECIFICATIONS IN ACCORDANCE WITH SECTION 148-1-4(F) OF THE WEST VIRGINIA LEGISLATIVE RULES AND REGULATIONS. EXHIBIT 5 WEST VIRGINIA CODE 21-1D-5 PROVIDES THAT: ANY SOLICITATION FOR A PUBLIC IMPROVEMENT CONSTRUCTION CONTRACT REQUIRES EACH VENDOR THAT SUBMITS A BID FOR THE WORK TO SUBMIT AT THE SAME TIME AN AFFIDAVIT OF COMPLIANCE WITH THE BID. THE ENCLOSED DRUG-FREE WORKPLACE AFFIDAVIT MUST BE SIGNED AND SUBMITTED WITH THE BID AS EVIDENCE OF THE VENDOR'S COMPLIANCE WITH THE PROVISIONS OF ARTICLE 1D, CHAPTER 21 OF THE WEST VIRGINIA CODE. FAILURE TO SUBMIT THE SIGNED DRUG-FREE WORKPLACE AFFIDAVIT WITH THE BID SHALL RESULT IN DISQUALIFICATION OF SUCH BID. NOTICE TO PROCEED: THIS CONTRACT IS TO BE PERFORMED						

SEE REVERSE SIDE FOR TERMS AND CONDITIONS

SIGNATURE	TELEPHONE	DATE
TITLE	FEIN	ADDRESS CHANGES TO BE NOTED ABOVE

WHEN RESPONDING TO RFQ, INSERT NAME AND ADDRESS IN SPACE ABOVE LABELED 'VENDOR'



State of West Virginia
 Department of Administration
 Purchasing Division
 2019 Washington Street East
 Post Office Box 50130
 Charleston, WV 25305-0130

Request for Quotation

RFQ NUMBER
BVH391

PAGE
4

ADDRESS CORRESPONDENCE TO ATTENTION OF:
TARA LYLE 304-558-2544

VENDOR	RFQ COPY
	TYPE NAME/ADDRESS HERE

SHIP TO	WEST VIRGINIA VETERANS HOME
	512 WATER STREET BARBOURSVILLE, WV 25504 736-1027

DATE PRINTED	TERMS OF SALE	SHIP VIA	F.O.B.	FREIGHT TERMS
08/31/2011				

BID OPENING DATE: 10/05/2011 BID OPENING TIME 01:30PM

LINE	QUANTITY	UOP	CAT NO	ITEM NUMBER	UNIT PRICE	AMOUNT
<p>WITHIN 60 CALENDAR DAYS AFTER THE NOTICE TO PROCEED IS RECEIVED. UNLESS OTHERWISE SPECIFIED, THE FULLY EXECUTED PURCHASE ORDER WILL BE CONSIDERED NOTICE TO PROCEED.</p> <p>CANCELLATION: THE DIRECTOR OF PURCHASING RESERVES THE RIGHT TO CANCEL THIS CONTRACT IMMEDIATELY UPON WRITTEN NOTICE TO THE VENDOR IF THE MATERIALS OR WORKMANSHIP SUPPLIED ARE OF AN INFERIOR QUALITY OR DO NOT CONFORM WITH THE SPECIFICATIONS OF THE BID AND CONTRACT HERE IN.</p> <p>WAGE RATES: THE CONTRACTOR OR SUBCONTRACTOR SHALL PAY THE HIGHER OF THE U.S. DEPARTMENT OF LABOR MINIMUM WAGE RATES AS ESTABLISHED FOR CABELL COUNTY, PURSUANT TO WEST VIRGINIA CODE 21-5A, ET, SEQ. (PREVAILING WAGE RATES APPLY TO THIS PROJECT)</p> <p>ARBITRATION: ANY REFERENCES MADE TO ARBITRATION OR INTEREST FOR PAYMENTS DUE (EXCEPT FOR ANY INTEREST REQUIRED BY STATE LAW) CONTAINED IN THIS CONTRACT OR IN ANY AMERICAN INSTITUTE OF ARCHITECTS DOCUMENTS PERTAINING TO THIS CONTRACT ARE HEREBY DELETED.</p> <p>WORKERS' COMPENSATION: VENDOR IS REQUIRED TO PROVIDE A CERTIFICATE FROM WORKERS' COMPENSATION IF SUCCESSFUL.</p> <p>ALL OF THE ITEMS CHECKED BELOW WILL BE A REQUIREMENT OF THIS CONTRACT:</p> <p>(XX) INSURANCE: SUCCESSFUL VENDOR SHALL FURNISH PROOF OF COMMERCIAL GENERAL LIABILITY INSURANCE PRIOR TO ISSUANCE OF CONTRACT. UNLESS OTHERWISE SPECIFIED IN THE BID DOCUMENTS, THE MINIMUM AMOUNT OF INSURANCE COVERAGE REQUIRED IS \$250,000.</p>						

SEE REVERSE SIDE FOR TERMS AND CONDITIONS

SIGNATURE	TELEPHONE	DATE
		10/4/11
TITLE	ADDRESS CHANGES TO BE NOTED ABOVE	
Pres.		

WHEN RESPONDING TO RFQ, INSERT NAME AND ADDRESS IN SPACE ABOVE LABELED 'VENDOR'



State of West Virginia
 Department of Administration
 Purchasing Division
 2019 Washington Street East
 Post Office Box 50130
 Charleston, WV 25305-0130

Request for Quotation

RFQ NUMBER
BVH391

PAGE
6

ADDRESS CORRESPONDENCE TO ATTENTION OF:
TARA LYLE
304-558-2544

RFQ COPY

TYPE NAME/ADDRESS HERE

VENDOR

SHIP TO

WEST VIRGINIA VETERANS HOME

512 WATER STREET
 BARBOURSVILLE, WV
 25504 736-1027

DATE PRINTED	TERMS OF SALE	SHIP VIA	F.O.B.	FREIGHT TERMS
08/31/2011				

BID OPENING DATE: 10/05/2011 BID OPENING TIME 01:30PM

LINE	QUANTITY	UOP	CAT. NO.	ITEM NUMBER	UNIT PRICE	AMOUNT
<p>STEEL ARE REQUIRED, THE STATE WILL ACCEPT ONLY ALUMINUM GLASS, OR STEEL PRODUCTS PRODUCED IN THE UNITED STATES. IN ADDITION, ITEMS OF MACHINERY OR EQUIPMENT PURCHASED FOR USE AT THE SITE OF PUBLIC WORKS SHALL BE MADE OF DOMESTIC ALUMINUM, GLASS OR STEEL, UNLESS THE COST OF THE PRODUCT IS LESS THAN \$50,000 OR LESS THAN 10,000 POUNDS OF STEEL ARE USED IN PUBLIC WORKS PROJECTS.</p> <p>FOREIGN MADE ALUMINUM, GLASS OR STEEL PRODUCTS MAY BE ACCEPTED ONLY IF THE COST OF DOMESTIC PRODUCTS IS FOUND TO BE UNREASONABLE. SUCH COST IS UNREASONABLE IF IT IS 20% OR MORE HIGHER THAN THE BID PRICE FOR FOREIGN MADE PRODUCTS. IF THE DOMESTIC ALUMINUM, GLASS OR STEEL PRODUCTS TO BE SUPPLIED OR PRODUCED IN A "SUBSTANTIAL LABOR SURPLUS AREA", AS DEFINED BY THE UNITED STATES DEPARTMENT OF LABOR, FOREIGN PRODUCTS MAY BE SUPPLIED ONLY IF DOMESTIC PRODUCTS ARE 30% OR MORE HIGHER IN PRICE THAN THE FOREIGN MADE PRODUCTS.</p> <p>IF, PRIOR TO THE AWARD OF A CONTRACT UNDER THE ABOVE PROVISIONS, THE SPENDING OFFICER OF THE SPENDING UNIT DETERMINES THAT THERE EXISTS A BID FOR LIKE FOREIGN ALUMINUM, GLASS OR STEEL THAT IS REASONABLE AND LOWER THAN THE LOWEST BID DOMESTIC PRODUCTS, THE SPENDING OFFICE MAY REQUEST, IN WRITING, A REEVALUATION AND REDUCTION IN THE LOWEST BID FOR SUCH DOMESTIC PRODUCTS. ALL VENDORS MUST INDICATE IN THEIR BID IF THEY ARE SUPPLYING FOREIGN ALUMINUM, GLASS OR STEEL.</p> <p>REV. 3/88</p> <p>EXHIBIT 9</p> <p>NOTICE FOR ISSUANCE & ACKNOWLEDGEMENT OF CONSTRUCTION PROJECT ADDENDA</p>						

SEE REVERSE SIDE FOR TERMS AND CONDITIONS

SIGNATURE	TELEPHONE	DATE
		10/1/11
TITLE	FEIN	ADDRESS CHANGES TO BE NOTED ABOVE
Pres		

WHEN RESPONDING TO RFQ, INSERT NAME AND ADDRESS IN SPACE ABOVE LABELED 'VENDOR'



State of West Virginia
 Department of Administration
 Purchasing Division
 2019 Washington Street East
 Post Office Box 50130
 Charleston, WV 25305-0130

Request for Quotation

RFQ NUMBER
 BVH391

PAGE
 7

ADDRESS CORRESPONDENCE TO ATTENTION OF:
 TARA LYLE
 304-558-2544

RFQ COPY
 TYPE NAME/ADDRESS HERE

VENDOR

SHIP TO

WEST VIRGINIA VETERANS HOME
 512 WATER STREET
 BARBOURSVILLE, WV
 25504 736-1027

DATE PRINTED	TERMS OF SALE	SHIP VIA	F.O.B.	FREIGHT TERMS
08/31/2011				

BID OPENING DATE: 10/05/2011 BID OPENING TIME 01:30PM

LINE	QUANTITY	UOP	CAT NO.	ITEM NUMBER	UNIT PRICE	AMOUNT
<p>THE ARCHITECT/ENGINEER AND/OR AGENCY SHALL BE REQUIRED TO ABIDE BY THE FOLLOWING SCHEDULE IN ISSUING CONSTRUCTION PROJECT ADDENDA FOR STATE AGENCIES:</p> <p>(1) THE ARCHITECT/ENGINEER SHALL PREPARE THE ADDENDUM AND A LIST OF ALL PARTIES THAT HAVE PROCURED DRAWINGS AND SPECIFICATIONS FOR THE PROJECT. THE ADDENDUM AND LIST SHALL BE FORWARDED TO THE BUYER IN THE STATE PURCHASING DIVISION. THE ARCHITECT/ENGINEER SHALL ALSO SEND A COPY OF THE ADDENDUM TO THE STATE AGENCY FOR WHICH THE CONTRACT IS ISSUED.</p> <p>(2) THE BUYER SHALL SEND THE ADDENDUM TO ALL INTERESTED PARTIES AND, IF NECESSARY, EXTEND THE BID OPENING DATE. ANY ADDENDUM SHOULD BE RECEIVED BY THE BUYER WITHIN FOURTEEN (14) DAYS PRIOR TO THE BID OPENING DATE.</p> <p>(3) ALL ADDENDA SHOULD BE FORMALLY ACKNOWLEDGED BY ALL BIDDERS AND SUBMITTED TO THE STATE PURCHASING DIVISION. THE SAME RULES AND REGULATIONS THAT APPLY TO THE ORIGINAL BIDDING DOCUMENT SHALL ALSO APPLY TO AN ADDENDUM DOCUMENT. THE ONLY EXCEPTION MAY BE FOR AN ADDENDUM THAT IS ISSUED FOR THE SOLE PURPOSE OF CHANGING A BID OPENING TIME AND/OR DATE.</p> <p>REV. 11/96</p> <p>EXHIBIT 10</p> <p>ADDENDUM ACKNOWLEDGEMENT</p> <p>I HEREBY ACKNOWLEDGE RECEIPT OF THE FOLLOWING CHECKED</p>						

SEE REVERSE SIDE FOR TERMS AND CONDITIONS

SIGNATURE	TELEPHONE	DATE
TITLE	FEIN	ADDRESS CHANGES TO BE NOTED ABOVE

WHEN RESPONDING TO RFQ, INSERT NAME AND ADDRESS IN SPACE ABOVE LABELED 'VENDOR'



State of West Virginia
 Department of Administration
 Purchasing Division
 2019 Washington Street East
 Post Office Box 50130
 Charleston, WV 25305-0130

Request for Quotation

RFQ NUMBER
BVH391

PAGE
8

ADDRESS CORRESPONDENCE TO ATTENTION OF:
TARA LYLE
304-558-2544

VENDOR

RFQ COPY
 TYPE NAME/ADDRESS HERE

SHIP TO

WEST VIRGINIA VETERANS HOME

 512 WATER STREET
 BARBOURSVILLE, WV
 25504 736-1027

DATE PRINTED 08/31/2011	TERMS OF SALE	SHIP VIA	F.O.B.	FREIGHT TERMS
----------------------------	---------------	----------	--------	---------------

BID OPENING DATE: 10/05/2011 BID OPENING TIME 01:30PM

LINE	QUANTITY	UOP	CAT. NO.	ITEM NUMBER	UNIT PRICE	AMOUNT
<p>ADDENDUM(S) AND HAVE MADE THE NECESSARY REVISIONS TO MY PROPOSAL, PLANS AND/OR SPECIFICATION, ETC.</p> <p>ADDENDUM NOS. :</p> <p>NO. 1</p> <p>NO. 2</p> <p>NO. 3</p> <p>NO. 4</p> <p>NO. 5</p> <p>I UNDERSTAND THAT FAILURE TO CONFIRM THE RECEIPT OF THE ADDENDUM(S) MAY BE CAUSE FOR REJECTION OF THE BIDS.</p> <p>VENDOR MUST CLEARLY UNDERSTAND THAT ANY VERBAL REPRESENTATION MADE OR ASSUMED TO BE MADE DURING ANY ORAL DISCUSSION HELD BETWEEN VENDOR'S REPRESENTATIVES AND ANY STATE PERSONNEL IS NOT BINDING. ONLY THE INFORMATION ISSUED IN WRITING AND ADDED TO THE SPECIFICATIONS BY AN OFFICIAL ADDENDUM IS BINDING.</p> <p>.....SIGNATURE</p> <p>INDEPENDENT HARDWARE INC.COMPANY</p> <p>10/4/11DATE</p> <p>REV. 11/96</p> <p>CONTRACTORS LICENSE</p>						

SEE REVERSE SIDE FOR TERMS AND CONDITIONS

SIGNATURE 	TELEPHONE	DATE 10/4/11
TITLE Ples	FEIN [REDACTED]	ADDRESS CHANGES TO BE NOTED ABOVE

WHEN RESPONDING TO RFQ, INSERT NAME AND ADDRESS IN SPACE ABOVE LABELED 'VENDOR'



State of West Virginia
 Department of Administration
 Purchasing Division
 2019 Washington Street East
 Post Office Box 50130
 Charleston, WV 25305-0130

Request for Quotation

RFQ NUMBER
BVH391

PAGE
11

ADDRESS CORRESPONDENCE TO ATTENTION OF:
TARA LYLE 304-558-2544

RFQ COPY
 TYPE NAME/ADDRESS HERE

VENDOR

SHIP TO

WEST VIRGINIA VETERANS HOME

 512 WATER STREET
 BARBOURSVILLE, WV
 25504 736-1027

DATE PRINTED	TERMS OF SALE	SHIP VIA	F.O.B.	FREIGHT TERMS
08/31/2011				

BID OPENING DATE: 10/05/2011 BID OPENING TIME 01:30PM

LINE	QUANTITY	UOP	CAT NO.	ITEM NUMBER	UNIT PRICE	AMOUNT
----- PLEASE PRINT OR TYPE NAME OF PERSON TO CONTACT CONCERNING THIS QUOTE: ----- <i>FRANK Stanco, 1-800-346-9464 X605</i> -----						
***** THIS IS THE END OF RFQ BVH391 ***** TOTAL: _____						

SEE REVERSE SIDE FOR TERMS AND CONDITIONS

SIGNATURE	TELEPHONE	DATE
TITLE	FEIN	ADDRESS CHANGES TO BE NOTED ABOVE

WHEN RESPONDING TO RFQ, INSERT NAME AND ADDRESS IN SPACE ABOVE LABELED 'VENDOR'

BVH391
LOCKS AND LOCKSETS

The Barboursville Veterans Home is seeking bids to provide and install lock and lock sets in various buildings located at 512 Water Street Barboursville, WV.

Vendor will provide all necessary materials, tools, supervision and labor to complete this project. Installation of locks to be performed by certified locksmith that is a member of the Associated Locksmiths of America or an equally accredited organization.

See attached chart for total lock counts.

All locks and locksets are to be Grade 1, of a current production, with available repair or replacement parts for at least a (3) three year period after the date of installation.

All locks and locksets to be of open stock availability with the flexibility of interchangeable parts.

All handled locksets to be lever type/ ADA compliant.

Must supply (4) end user keys for each lock, deadbolt, rim and mortise cylinder.

Must supply (6) six sub-masters for each building – Building A, B, C, D, E, J, H.

Must supply (4) four Master keys compatible with every locking device installed.

Must supply (1) one box of blanks.

** See attached chart. The existing fire door hardware, hinges, panic/ crash bars and door closers will not be replaced under this contract but are to be inspected and certified that each operates freely and correctly as per Manufacturers' specs. If the existing fire door hardware, hinges, panic/crash bars and door closer are found to be defective, the vendor will supply the agency with a listing of required repairs. These repairs or replacements of parts will not be covered under this contract.

Contractor must certify that all newly installed locks and locksets operate correctly (lock and unlock) as per Manufacturers' specifications upon completion of installation prior to payment.

Lock counts and lock types must be field verified by the prospective vendor before installation.

All locks, locksets and installation must carry at least a one year warranty.

Existing Medeco locks that currently are in place in Building J will not be replaced.

Award: The contract will be awarded to one vendor with the lowest grand total amount meeting all of the specifications.

Bidders should include delivery in the bid total. Vendor must deliver and handle all items according to the manufacturer's recommendation. Items must be delivered in the manufacturer's original sealed containers complete with labels and instructions.

Vendor should provide the manufacturer name and model number of the product being bid on the bid form.

	ENTRANCE/ LEVERSET	STOREROOM/ LEVERSET	SINGLE CYLINDER DEADBOLT	DOUBLE CYLINDER DEADBOLT	RIM CYLINDER	MORTISE CYLINDER	PRIVACY/ LEVERSET	**PANIC FIRE HARDWARE	PASSAGE
A	19	2	14	1	6		2	6	
J	7	4	5		3		3	5	3
B	33	13	4		17			18	
C	37	19	19		27		3	26	
Includes 1 knob									
D	47	11	9	* 2	24	2	1	28	
E	4	2	1		3		1	3	
H	4	1	3		2			3	
TOTALS	151	52	55	3	82	2	10	89	3
*Exact type is not known.									
** Panic Fire Hardware count is for inspection and certification that each operates freely and correctly only									

**BVH391-West Virginia Veterans Home
Bid Form**

Item No.	Item Description	Model No.	Quantity	Unit Price	Extended Price
1	ENTRANCE/LEVERSET	PDQ GT 116-PhL-626.	151	\$ 101.88	\$ 15,383.88
2	STOREROOM/LEVERSET	PDQ GT 115-PhL-626	52	\$ 101.88	\$ 5,297.76 50*
3	SINGLE CYLINDER DEADBOLT	PDQ K 116-626	55	\$ 38.76	\$ 2,131.80
4	DOUBLE CYLINDER DEADBOLT	PDQ K 137-626	3	\$ 42.00	\$ 126.00
5	RIM CYLINDER	Ilco-7015-26D	82	\$ 19.50	\$ 1599.00
6	MORTISE CYLINDER	Ilco-7100-26D	2	\$ 19.50	\$ 39.00
7	PRIVACY/LEVERSET	PDQ GT 176-PhL 626	10	\$ 85.00	\$ 850.00
8	PANIC FIRE HARDWARE	INSPECT PANICS ONLY	89	\$ 7.00	\$ 623.00
9	PASSAGE	PDQ GT 126-PhL-626	3	\$ 78.80	\$ 236.40.
10	Box of Blanks	Schlage SC1	1	\$	\$ 20.00

GRAND TOTAL: 26,306.84

Company Name: INDEPENDENT HARDWARE INC

Contact Name: FRANK STANCO

Company Address: 14. S. FRONT ST
Philadelphia, Pa 19106

Phone No.: 800-346-9464 x605

Fax No.: 215-922-6552

RFQ No. BVH391

STATE OF WEST VIRGINIA
Purchasing Division

PURCHASING AFFIDAVIT

West Virginia Code §5A-3-10a states: No contract or renewal of any contract may be awarded by the state or any of its political subdivisions to any vendor or prospective vendor when the vendor or prospective vendor or a related party to the vendor or prospective vendor is a debtor and the debt owed is an amount greater than one thousand dollars in the aggregate.

DEFINITIONS:

"Debt" means any assessment, premium, penalty, fine, tax or other amount of money owed to the state or any of its political subdivisions because of a judgment, fine, permit violation, license assessment, defaulted workers' compensation premium, penalty or other assessment presently delinquent or due and required to be paid to the state or any of its political subdivisions, including any interest or additional penalties accrued thereon.

"Debtor" means any individual, corporation, partnership, association, limited liability company or any other form or business association owing a debt to the state or any of its political subdivisions. "Political subdivision" means any county commission; municipality; county board of education; any instrumentality established by a county or municipality; any separate corporation or instrumentality established by one or more counties or municipalities, as permitted by law; or any public body charged by law with the performance of a government function or whose jurisdiction is coextensive with one or more counties or municipalities. "Related party" means a party, whether an individual, corporation, partnership, association, limited liability company or any other form or business association or other entity whatsoever, related to any vendor by blood, marriage, ownership or contract through which the party has a relationship of ownership or other interest with the vendor so that the party will actually or by effect receive or control a portion of the benefit, profit or other consideration from performance of a vendor contract with the party receiving an amount that meets or exceed five percent of the total contract amount.

EXCEPTION: The prohibition of this section does not apply where a vendor has contested any tax administered pursuant to chapter eleven of this code, workers' compensation premium, permit fee or environmental fee or assessment and the matter has not become final or where the vendor has entered into a payment plan or agreement and the vendor is not in default of any of the provisions of such plan or agreement.

Under penalty of law for false swearing (*West Virginia Code §61-5-3*), it is hereby certified that the vendor affirms and acknowledges the information in this affidavit and is in compliance with the requirements as stated.

WITNESS THE FOLLOWING SIGNATURE

Vendor's Name: INDEPENDENT HARDWARE INC.

Authorized Signature: [Signature] Date: 10-4-11

State of PA

County of Philadelphia, to-wit:

Taken, subscribed, and sworn to before me this 4 day of OCTOBER, 2011.

My Commission expires 8/31/, 2014.

AFFIX SEAL HERE

NOTARY PUBLIC [Signature]
NOTARIAL SEAL
VINCENT CAMPAGNA
Notary Public
CITY OF PHILADELPHIA, PHILADELPHIA COUNTY
My Commission Expires Aug 31, 2014



State of West Virginia
DRUG FREE WORKPLACE CONFORMANCE AFFIDAVIT
West Virginia Code §21-1D-5

STATE OF PA

COUNTY OF Philadelphia., TO-WIT:

I, FRANK STANCO, after being first duly sworn, depose and state as follows:

- 1. I am an employee of INDEPENDENT HARDWARE, INC.; and,
(Company Name)
- 2. I do hereby attest that INDEPENDENT HARDWARE, INC.
(Company Name)

maintains a valid written drug free workplace policy and that such policy is in compliance with **West Virginia Code** §21-1D-5.

The above statements are sworn to under the penalty of perjury.

INDEPENDENT HARDWARE, INC.
(Company Name)

By: [Signature] FRANK STANCO

Title: President

Date: 10-4-11

Taken, subscribed and sworn to before me this 4 day of OCTOBER, 2011

By Commission expires 8/31/2014

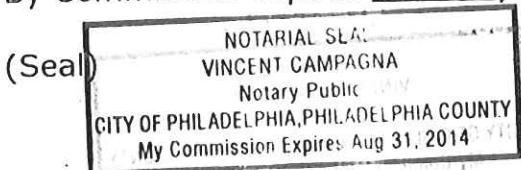

[Signature]
(Notary Public)

THIS AFFIDAVIT MUST BE SUBMITTED WITH THE BID IN ORDER TO COMPLY WITH WV CODE PROVISIONS. FAILURE TO INCLUDE THE AFFIDAVIT WITH THE BID SHALL RESULT IN DISQUALIFICATION OF THE BID.

BID BOND PREPARATION INSTRUCTIONS

AGENCY (A)
RFQ/RFP# (B)

Bid Bond

- (A) WV State Agency (Stated on Page 1 "Spending Unit") Request for Quotation Number (upper right corner of page #1)
(C) Your Company Name
(D) City, Location of your Company
(E) State, Location of your Company
(F) Surety Corporate Name
(G) City, Location of Surety
(H) State, Location of Surety
(I) State of Surety Incorporation
(J) City of Surety Incorporation
(K) Minimum amount of acceptable bid bond is 5% of total bid. You may state "5% of bid" or a specific amount on this line in words.
(L) Amount of bond in figures
(M) Brief Description of scope of work
(N) Day of the month
(O) Month
(P) Year
(Q) Name of Corporation
(R) Raised Corporate Seal of Principal
(S) Signature of President or Vice President
(T) Title of person signing
(U) Raised Corporate Seal of Surety
(V) Corporate Name of Surety
(W) Signature of Attorney in Fact of the Surety
NOTE: Dated, Power of Attorney with Raised Surety Seal must accompany this bid bond.

KNOW ALL MEN BY THESE PRESENTS, That we, the undersigned, (C) of (D), (E) as Principal, and (F) of (G), (H), a corporation organized and existing under the laws of the State of (I) with its principal office in the City of (J), as Surety, are held and firmly bound unto The State of West Virginia, as Obligee, in the penal sum of (K) (\$ (L)) for the payment of which, well and truly to be made, we jointly and severally bind ourselves, our heirs, administrators, executors, successors and assigns.

The Condition of the above obligation is such that whereas the Principal has submitted to the Purchasing Section of the Department of Administration a certain bid or proposal, attached hereto and made a part hereof to enter into a contract in writing for (M)

NOW THEREFORE.

(a) If said bid shall be rejected, or
(b) If said bid shall be accepted and the Principal shall enter into a contract in accordance with the bid or proposal attached hereto and shall furnish any other bonds and insurance required by the bid or proposal, and shall in all other respects perform the agreement created by the acceptance of said bid then this obligation shall be null and void, otherwise this obligation shall remain in full force and effect. It is expressly understood and agreed that the liability of the Surety for any and all claims hereunder shall, in no event, exceed the penal amount of this obligation as herein stated

The Surety for value received, hereby stipulates and agrees that the obligations of said Surety and its bond shall be in no way impaired or affected by any extension of time within which the Obligee may accept such bid: and said Surety does hereby waive notice of any such extension.

IN WITNESS WHEREOF, Principal and Surety have hereunto set their hands and seals, and such of them as are corporations have caused their corporate seals to be affixed hereto and these presents to be signed by their proper officers, this (N) day of (O), 20 (P).

Principal Corporate Seal (R) (Q) (Name of Principal)
By (S) (Must be President or Vice President)
(T) Title
(U) Surety Corporate Seal (V) (Name of Surety)
(W) Attorney-in-Fact

IMPORTANT - Surety executing bonds must be licensed in West Virginia to transact surety insurance. Raised Corporate Seals must be affixed and a Power of Attorney must be attached.

Agency _____
REQ.P.O# _____

BID BOND

KNOW ALL MEN BY THESE PRESENTS, That we, the undersigned, INDEPENDENT HARDWARE, INC.
of 14.5. FRONT ST, Philadelphia, Pa 19106, as Principal, and _____
of _____, _____, a corporation organized and existing under the laws of the State of _____
with its principal office in the City of _____, as Surety, are held and firmly bound unto the State
of West Virginia, as Obligee, in the penal sum of 1316.00 (\$ 1360.00) for the payment of which,
well and truly to be made, we jointly and severally bind ourselves, our heirs, administrators, executors, successors and assigns.

The Condition of the above obligation is such that whereas the Principal has submitted to the Purchasing Section of the
Department of Administration a certain bid or proposal, attached hereto and made a part hereof, to enter into a contract in writing for

NOW THEREFORE,

(a) If said bid shall be rejected, or
(b) If said bid shall be accepted and the Principal shall enter into a contract in accordance with the bid or proposal attached
hereto and shall furnish any other bonds and insurance required by the bid or proposal, and shall in all other respects perform the
agreement created by the acceptance of said bid, then this obligation shall be null and void, otherwise this obligation shall remain in full
force and effect. It is expressly understood and agreed that the liability of the Surety for any and all claims hereunder shall, in no event,
exceed the penal amount of this obligation as herein stated.

The Surety, for the value received, hereby stipulates and agrees that the obligations of said Surety and its bond shall be in no
way impaired or affected by any extension of the time within which the Obligee may accept such bid, and said Surety does hereby
waive notice of any such extension.

IN WITNESS WHEREOF, Principal and Surety have hereunto set their hands and seals, and such of them as are corporations
have caused their corporate seals to be affixed hereunto and these presents to be signed by their proper officers, this

4 day of October, 20 .

Principal Corporate Seal

FRANK STANCO

(Name of Principal)
By [Signature] Pres.

(Must be President or
Vice President)
President

(Title)

Surety Corporate Seal

(Name of Surety)

Attorney-in-Fact

**IMPORTANT – Surety executing bonds must be licensed in West Virginia to transact surety insurance. Raised corporate seals
must be affixed, a power of attorney must be attached.**

34410

H INDEPENDENT
HARDWARE
INCORPORATED

14 SOUTH FRONT ST.
PHILADELPHIA, PA 19106
215-925-5306

PNC BANK, N.A.
PHILADELPHIA, PA 020

3-5 (884)
310

10/04/11

PAY TO THE ORDER OF STATE OF WEST VIRGINIA

*****1,316.00

One Thousand Three Hundred Sixteen Dollars And No Cents

\$

DOLLARS

STATE OF WEST VIRGINIA



MEMO

- [PriceBook-2011R4](#)
- [Price List Revisions](#)
- [Fast Order Form](#)
-
- [REP LOGIN](#)
-
- [CONTACT](#)

INDEPENDENT HARDWARE INC.
 14 South Front Street
 Philadelphia, PA 19106-3001

[Home](#) › [PRODUCTS](#) › [Locks](#) › [Cylindrical Locks](#) › [GT Series](#)

GT Series Cylindrical Lock

GT series SPIRIT from PDQ Industries, Inc. Leola, Pennsylvania, assembled in the USA, meeting the requirements of the Buy American Act with a twenty-five year manufacturer's limited warranty, and be certified to ANSI A156.2, Series 4000, Grade 1.

Windstorm Resistant Product Listed - ANSI A250.13-2003, ASTM E1886-02, ASTM E330-02. Outswing: 350 ft-lbs., Inswing: N/R, Design Load Rating: 1485lbf. Locksets shall be listed by UL / ULC for ratings of "A" label (3 hours) and less, [UL10C / UBC 7-2 \(1997\)](#) positive pressure, for single doors up to 4'0" x 8'0".

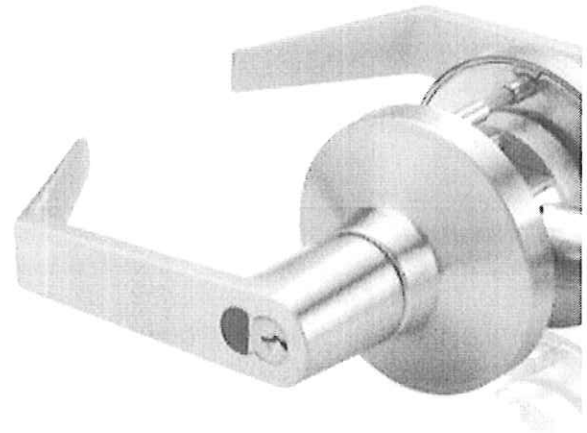

Solid cast levers with no plastic inserts, minimum 5-1/2" overall length with supportive spring power totally independent of chassis or latch unit. 9/16" throw latch requires only 41° rotation of levers for full retraction. Concealed fasteners with through-the-bolt attachment outside the 2-1/8" door prep

Exceeds 2400 in lbs. of torque resistance. The GT has been tested to more than **2 Million cycles** (more times the BHMA Grade 1 requirement) with virtually no lever sag.







GT Lock Specifications

FOR DOORS: 1-3/4" to 2-1/4" thick. Factory adjusted for 1-3/4".

DOOR PREP: Fits standard 161 door prep. Through-door thru-bolting.



GT SERIES SPIRIT EXTRA HEAVY DUTY GRADE 1 FUNCTION CHART

FUNCTION	FUNCTION NO.	INSIDE	OUTSIDE	FUNCTION DESCRIPTION
Entrance	GT 116			<ul style="list-style-type: none"> Latchbolt operated by lever from either side or key in outside lever Outside lever locked by push/turn button on inside When outside lever is locked by push button on inside – key from outside, or rotating inside lever unlocks outside lever When outside lever is locked by pushing and turning button on the inside, key outside or rotating inside lever retracts latch but does not unlock outside lever
Store Room	GT 115			<ul style="list-style-type: none"> Latchbolt operated by inside lever or key in outside lever Outside lever always fixed
Class Room	GT 143			<ul style="list-style-type: none"> Latchbolt operated by lever from either side Outside lever locked by key from outside Outside lever unlocked by key from outside Inside lever always operates latch
Entry	GT 182			<ul style="list-style-type: none"> Latchbolt operated by lever from either side or key in outside lever Outside lever locked by push button on inside Outside lever unlocked by key from outside
Service Station	GT 155			<ul style="list-style-type: none"> Latchbolt operated by lever from either side or key in outside lever Outside lever locked by push button on inside When outside lever is locked by push button on inside – key from outside, rotating inside lever, or closing door unlocks outside lever When outside lever is locked by pushing and turning the slotted button on the inside key from outside or rotating inside lever retracts latch but does not unlock outside
Passage/Closet	GT 126			<ul style="list-style-type: none"> Latchbolt operated by lever from either side at all times
Privacy Bedroom/Bathroom	GT 176			<ul style="list-style-type: none"> Latchbolt operated by lever from either side or emergency release in outside lever Outside lever locked by push button on inside Outside lever unlocked by emergency release from outside, rotating inside lever or closing door
Exit	GT 124			<ul style="list-style-type: none"> Latchbolt operated by inside lever at all times Outside lever always fixed Outside lever has non-removable security features
Patio	GT 177			<ul style="list-style-type: none"> Latchbolt operated by lever from either side Outside lever locked by push button on inside Outside lever unlocked by rotating inside lever, or closing door Outside lever has non-removable security features
Hospital Privacy	GT 175			<ul style="list-style-type: none"> Latchbolt operated by lever from either side or emergency turn piece in outside Outside lever locked by push button on inside Outside lever unlocked by emergency turn piece from outside, rotating inside lever or closing door
General Entry	GT 137			<ul style="list-style-type: none"> Latchbolt operated by lever from either side Both levers locked by key from either side Both levers unlocked by key from either side
Communicating	GT 141			<ul style="list-style-type: none"> Latchbolt operated by lever from either side Key in either side locks or unlocks its own lever independently
Utility Asylum/Institution	GT 123			<ul style="list-style-type: none"> Latchbolt operated by key from either side Both levers always fixed Should not be used on rooms that have no other exit
Security	GT 120			<ul style="list-style-type: none"> Latchbolt operated by lever from either side Key on outside locks inside lever Key on outside unlocks inside lever Outside keyed lever always free Inside lever has non-removable security features
Communicating	GT 125			<ul style="list-style-type: none"> Latchbolt operated by inside lever Blank plate outside Minimum clearance of 1-1/2" between doors Frame depth 7-1/8"
Exit or Tavn Communicating	GT 129			<ul style="list-style-type: none"> Latchbolt operated by key in inside lever Inside lever always fixed Blank plate outside Minimum clearance of 1-1/2" between doors Frame depth 7-1/8"

Vestibule Classroom Security	GT 135		<ul style="list-style-type: none"> Latchbolt operated by lever from either side Key in either lever locks outside lever Key in either lever unlocks outside lever Inside lever always free
Exit or Twin Communicating	GT 150		<ul style="list-style-type: none"> Latchbolt operated by inside lever Blank plate outside Inside lever locked by key inside Inside lever unlocked by key inside Minimum clearance of 1-1/2" between doors Use only in rooms with more than one exit Frame depth 7-1/8"
Dormitory/Corridor	GT 165		<ul style="list-style-type: none"> Latchbolt operated by lever from either side or key in outside lever Outside lever locked by key on outside or push button on inside Outside lever unlocked by key in outside lever, closing door, or rotating inside lever Inside lever always free
Double Dummy	GT 205		<ul style="list-style-type: none"> Pull lever both sides No mechanical operation
Single Dummy	GT 211		<ul style="list-style-type: none"> Pull lever one side No mechanical operation

Strikes

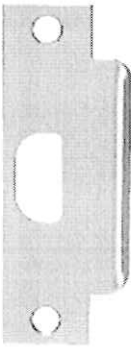
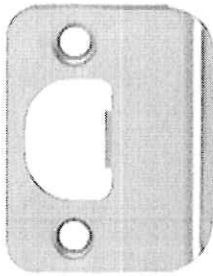
4-7/8" (ASA) strike included with every GT unless otherwise specified.

4-7/8" (ASA) STRIKE	FULL LIP STRIKE	T STRIKE
		
1-1/4" x 4-7/8" x 3/32"	1-5/8" x 2-1/4" x 3/32"	1-1/8" x 2-3/4" x 3/32"

Lever Styles

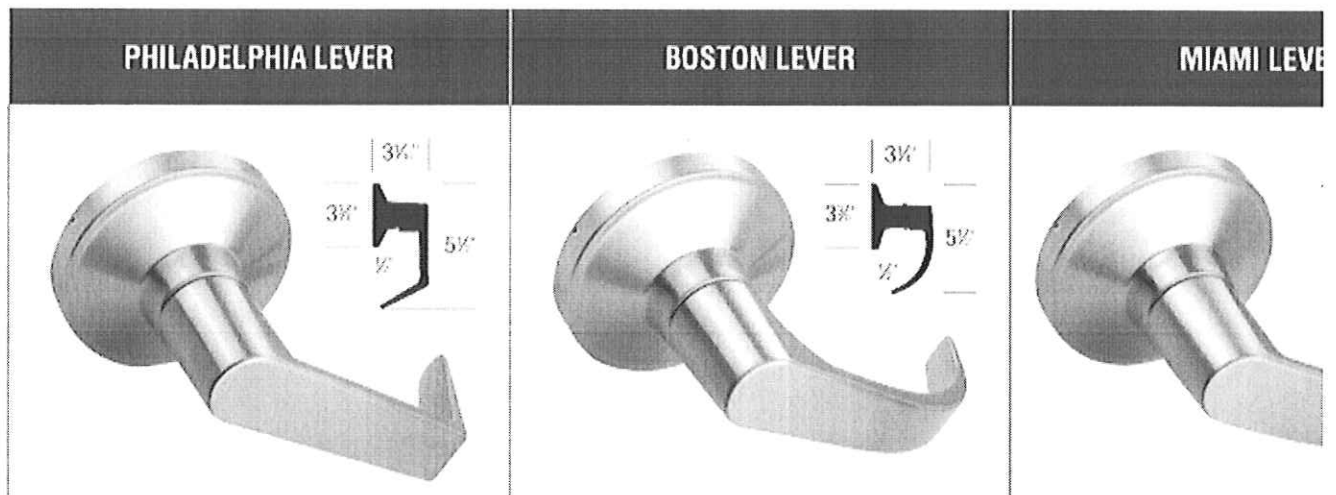

Architectural Spec Sheet

Click here for [GT Series Architectural Specification](#)

Parts List

[Download GT Parts List \(54.24 kB\)](#)

Copyright © 2011 PDQ Manufacturing.
All Rights Reserved.