

Flint

TRADING INC.®

115 Todd Court
Thomasville, NC 27360
Phone: (336) 475-6600
Fax: (336) 475-7900
flint@flintrading.com
www.flintrading.com

April 4, 2012

Mr. Allen Cummings
State of West Virginia
Department of Administration
Purchasing Division
2019 Washington Street East
Charleston, WV 25305

Reference: RFQ 8512C2034 Retroreflective Pavement Marking Materials

Dear Mr. Cummings,

Thank you for the opportunity to quote you on our PreMark® Preformed Thermoplastic Pavement Marking Material. Please find attached our completed bid for your RFQ 8512C2034 for Type V, Category II Preformed Retroreflective Pavement Marking Materials.

I trust this bid will meet with your approval. If you have any questions or require additional information, please do not hesitate to contact me at (336) 475-6600 or via e-mail at sales@flintrading.com. Thank you for considering Flint Trading, Inc. We look forward to serving the State of West Virginia.

Sincerely,



Tim Montgomery
Customer Sales and Support Manager

RECEIVED

2012 APR -6 AM 9:54

WV PURCHASING
DIVISION



State of West Virginia
 Department of Administration
 Purchasing Division
 2019 Washington Street East
 Post Office Box 50130
 Charleston, WV 25305-0130

Request for Quotation

RFQ NUMBER
8512C2034

PAGE
1

ADDRESS CORRESPONDENCE TO ATTENTION OF:
ALAN CUMMINGS 304-558-2402

RFQ COPY
 TYPE NAME/ADDRESS HERE

VENDOR

FLINT TRADING, INC.
 115 TODD CT.
 THOMASVILLE, NC 27360

SHIP TO

DIVISION OF HIGHWAYS
 VARIOUS LOCALES AS INDICATED
 BY ORDER

DATE PRINTED	TERMS OF SALE	SHIP VIA	F.O.B.	FREIGHT TERMS
03/25/2012				

BID OPENING DATE: 04/11/2012 BID OPENING TIME 01:30PM

LINE	QUANTITY	UOP	CAT. NO.	ITEM NUMBER	UNIT PRICE	AMOUNT
0001				765-43		
RETROREFLECTIVE PAVEMENT MARKING MATERIALS						
OPEN-END CONTRACT						
<p>THE WEST VIRGINIA STATE PURCHASING DIVISION FOR THE AGENCY, THE WEST VIRGINIA DIVISION OF HIGHWAYS, IS SOLICITING BIDS TO PROVIDE THE AGENCY WITH AN OPEN-END CONTRACT FOR TYPE V, CATEGORY II, PREFORMED RETROREFLECTIVE PAVEMENT MARKING MATERIALS AND REQUIRED APPLICATION ACCESSORIES TO VARIOUS WEST VIRGINIA DIVISION OF HIGHWAYS LOCATIONS AS NOTED HEREIN PER THE ATTACHED SPECIFICATIONS.</p> <p>EXHIBIT 3</p> <p>LIFE OF CONTRACT: THIS CONTRACT BECOMES EFFECTIVE ON AWARD AND EXTENDS FOR A PERIOD OF ONE (1) YEAR OR UNTIL SUCH "REASONABLE TIME" THEREAFTER AS IS NECESSARY TO OBTAIN A NEW CONTRACT OR RENEW THE ORIGINAL CONTRACT. THE "REASONABLE TIME" PERIOD SHALL NOT EXCEED TWELVE (12) MONTHS. DURING THIS "REASONABLE TIME" THE VENDOR MAY TERMINATE THIS CONTRACT FOR ANY REASON UPON GIVING THE DIRECTOR OF PURCHASING 30 DAYS WRITTEN NOTICE.</p> <p>UNLESS SPECIFIC PROVISIONS ARE STIPULATED ELSEWHERE IN THIS CONTRACT DOCUMENT BY THE STATE OF WEST VIRGINIA, ITS AGENCIES, OR POLITICAL SUBDIVISIONS, THE TERMS, CONDITIONS, AND PRICING SET FORTH HEREIN ARE FIRM FOR THE LIFE OF THE CONTRACT.</p>						

SEE REVERSE SIDE FOR TERMS AND CONDITIONS

SIGNATURE <i>Kevin Montague</i>	TELEPHONE (336) 475-6600	DATE 04/04/2012
TITLE Customer Sales & Support Manager	FEIN 56-1736552	ADDRESS CHANGES TO BE NOTED ABOVE

WHEN RESPONDING TO RFQ, INSERT NAME AND ADDRESS IN SPACE ABOVE LABELED 'VENDOR'

GENERAL TERMS & CONDITIONS
REQUEST FOR QUOTATION (RFQ) AND REQUEST FOR PROPOSAL (RFP)

1. Awards will be made in the best interest of the State of West Virginia.
2. The State may accept or reject in part, or in whole, any bid.
3. Prior to any award, the apparent successful vendor must be properly registered with the Purchasing Division and have paid the required \$125 fee.
4. All services performed or goods delivered under State Purchase Order/Contracts are to be continued for the term of the Purchase Order/Contracts, contingent upon funds being appropriated by the Legislature or otherwise being made available. In the event funds are not appropriated or otherwise available for these services or goods this Purchase Order/Contract becomes void and of no effect after June 30.
5. Payment may only be made after the delivery and acceptance of goods or services.
6. Interest may be paid for late payment in accordance with the *West Virginia Code*.
7. Vendor preference will be granted upon written request in accordance with the *West Virginia Code*.
8. The State of West Virginia is exempt from federal and state taxes and will not pay or reimburse such taxes.
9. The Director of Purchasing may cancel any Purchase Order/Contract upon 30 days written notice to the seller.
10. The laws of the State of West Virginia and the *Legislative Rules* of the Purchasing Division shall govern the purchasing process.
11. Any reference to automatic renewal is hereby deleted. The Contract may be renewed only upon mutual written agreement of the parties.
12. **BANKRUPTCY:** In the event the vendor/contractor files for bankruptcy protection, the State may deem this contract null and void, and terminate such contract without further order.
13. **HIPAA BUSINESS ASSOCIATE ADDENDUM:** The West Virginia State Government HIPAA Business Associate Addendum (BAA), approved by the Attorney General, is available online at www.state.wv.us/admin/purchase/vrc/hipaa.html and is hereby made part of the agreement provided that the Agency meets the definition of a Cover Entity (45 CFR §160.103) and will be disclosing Protected Health Information (45 CFR §160.103) to the vendor.
14. **CONFIDENTIALITY:** The vendor agrees that he or she will not disclose to anyone, directly or indirectly, any such personally identifiable information or other confidential information gained from the agency, unless the individual who is the subject of the information consents to the disclosure in writing or the disclosure is made pursuant to the agency's policies, procedures, and rules. Vendor further agrees to comply with the Confidentiality Policies and Information Security Accountability Requirements, set forth in <http://www.state.wv.us/admin/purchase/privacy/noticeConfidentiality.pdf>.
15. **LICENSING:** Vendors must be licensed and in good standing in accordance with any and all state and local laws and requirements by any state or local agency of West Virginia, including, but not limited to, the West Virginia Secretary of State's Office, the West Virginia Tax Department, and the West Virginia Insurance Commission. The vendor must provide all necessary releases to obtain information to enable the director or spending unit to verify that the vendor is licensed and in good standing with the above entities.
16. **ANTITRUST:** In submitting a bid to any agency for the State of West Virginia, the bidder offers and agrees that if the bid is accepted the bidder will convey, sell, assign or transfer to the State of West Virginia all rights, title and interest in and to all causes of action it may now or hereafter acquire under the antitrust laws of the United States and the State of West Virginia for price fixing and/or unreasonable restraints of trade relating to the particular commodities or services purchased or acquired by the State of West Virginia. Such assignment shall be made and become effective at the time the purchasing agency tenders the initial payment to the bidder.

I certify that this bid is made without prior understanding, agreement, or connection with any corporation, firm, limited liability company, partnership, or person or entity submitting a bid for the same material, supplies, equipment or services and is in all respects fair and without collusion or fraud. I further certify that I am authorized to sign the certification on behalf of the bidder or this bid.

INSTRUCTIONS TO BIDDERS

1. Use the quotation forms provided by the Purchasing Division. Complete all sections of the quotation form.
2. Items offered must be in compliance with the specifications. Any deviation from the specifications must be clearly indicated by the bidder. Alternates offered by the bidder as **EQUAL** to the specifications must be clearly defined. A bidder offering an alternate should attach complete specifications and literature to the bid. The Purchasing Division may waive minor deviations to specifications.
3. Unit prices shall prevail in case of discrepancy. All quotations are considered F.O.B. destination unless alternate shipping terms are clearly identified in the quotation.
4. All quotations must be delivered by the bidder to the office listed below prior to the date and time of the bid opening. Failure of the bidder to deliver the quotations on time will result in bid disqualifications: Department of Administration, Purchasing Division, 2019 Washington Street East, P.O. Box 50130, Charleston, WV 25305-0130
5. Communication during the solicitation, bid, evaluation or award periods, except through the Purchasing Division, is strictly prohibited (W.Va. C.S.R. §148-1-6.6).



State of West Virginia
 Department of Administration
 Purchasing Division
 2019 Washington Street East
 Post Office Box 50130
 Charleston, WV 25305-0130

Request for Quotation

RFQ NUMBER
8512C2034

PAGE
2

ADDRESS CORRESPONDENCE TO ATTENTION OF:
ALAN CUMMINGS 304-558-2402

VENDOR

RFQ COPY
 TYPE NAME/ADDRESS HERE

SHIP TO

DIVISION OF HIGHWAYS
 VARIOUS LOCALES AS INDICATED
 BY ORDER

DATE PRINTED	TERMS OF SALE	SHIP VIA	F.O.B.	FREIGHT TERMS
03/25/2012				
BID OPENING DATE: 04/11/2012		BID OPENING TIME 01:30PM		

LINE	QUANTITY	UOP	CAT. NO.	ITEM NUMBER	UNIT PRICE	AMOUNT
<p>RENEWAL: THIS CONTRACT MAY BE RENEWED UPON THE MUTUAL WRITTEN CONSENT OF THE SPENDING UNIT AND VENDOR, SUBMITTED TO THE DIRECTOR OF PURCHASING THIRTY (30) DAYS PRIOR TO THE EXPIRATION DATE. SUCH RENEWAL SHALL BE IN ACCORDANCE WITH THE TERMS AND CONDITIONS OF THE ORIGINAL CONTRACT AND SHALL BE LIMITED TO TWO (2) ONE (1) YEAR PERIODS.</p> <p>CANCELLATION: THE DIRECTOR OF PURCHASING RESERVES THE RIGHT TO CANCEL THIS CONTRACT IMMEDIATELY UPON WRITTEN NOTICE TO THE VENDOR IF THE COMMODITIES AND/OR SERVICE SUPPLIED ARE OF AN INFERIOR QUALITY OR DO NOT CONFORM TO THE SPECIFICATIONS OF THE BID AND CONTRACT HEREIN.</p> <p>OPEN MARKET CLAUSE: THE DIRECTOR OF PURCHASING MAY AUTHORIZE A SPENDING UNIT TO PURCHASE ON THE OPEN MARKET, WITHOUT THE FILING OF A REQUISITION OR COST ESTIMATE, ITEMS SPECIFIED ON THIS CONTRACT FOR IMMEDIATE DELIVERY IN EMERGENCIES DUE TO UNFORESEEN CAUSES (INCLUDING BUT NOT LIMITED TO DELAYS IN TRANSPORTATION OR AN UNANTICIPATED INCREASE IN THE VOLUME OF WORK.)</p> <p>QUANTITIES: QUANTITIES LISTED IN THE REQUISITION ARE APPROXIMATIONS ONLY, BASED ON ESTIMATES SUPPLIED BY THE STATE SPENDING UNIT. IT IS UNDERSTOOD AND AGREED THAT THE CONTRACT SHALL COVER THE QUANTITIES ACTUALLY ORDERED FOR DELIVERY DURING THE TERM OF THE CONTRACT, WHETHER MORE OR LESS THAN THE QUANTITIES SHOWN.</p> <p>ORDERING PROCEDURE: SPENDING UNIT(S) SHALL ISSUE A WRITTEN STATE CONTRACT ORDER (FORM NUMBER WV-39) TO THE VENDOR FOR COMMODITIES COVERED BY THIS CONTRACT. THE ORIGINAL COPY OF THE WV-39 SHALL BE MAILED TO THE VENDOR AS AUTHORIZATION FOR SHIPMENT, A SECOND COPY</p>						

SEE REVERSE SIDE FOR TERMS AND CONDITIONS

SIGNATURE <i>Alan Cummings</i>	TELEPHONE (336) 475-6600	DATE 04/04/2012
TITLE Customer Sales & Support Manager	FEIN 56-1736552	ADDRESS CHANGES TO BE NOTED ABOVE

WHEN RESPONDING TO RFQ, INSERT NAME AND ADDRESS IN SPACE ABOVE LABELED 'VENDOR'



State of West Virginia
 Department of Administration
 Purchasing Division
 2019 Washington Street East
 Post Office Box 50130
 Charleston, WV 25305-0130

Request for Quotation

RFQ NUMBER
8512C2034

PAGE
3

ADDRESS CORRESPONDENCE TO ATTENTION OF:
ALAN CUMMINGS 304-558-2402

VENDOR

RFQ COPY
 TYPE NAME/ADDRESS HERE

SHIP TO

DIVISION OF HIGHWAYS
 VARIOUS LOCALES AS INDICATED
 BY ORDER

DATE PRINTED	TERMS OF SALE	SHIP VIA	F.O.B.	FREIGHT TERMS
03/25/2012				

BID OPENING DATE: 04/11/2012 BID OPENING TIME 01:30PM

LINE	QUANTITY	UOP	CAT. NO.	ITEM NUMBER	UNIT PRICE	AMOUNT
<p>MAILED TO THE PURCHASING DIVISION, AND A THIRD COPY RETAINED BY THE SPENDING UNIT.</p> <p>BANKRUPTCY: IN THE EVENT THE VENDOR/CONTRACTOR FILES FOR BANKRUPTCY PROTECTION, THE STATE MAY DEEM THE CONTRACT NULL AND VOID, AND TERMINATE SUCH CONTRACT WITHOUT FURTHER ORDER.</p> <p>THE TERMS AND CONDITIONS CONTAINED IN THIS CONTRACT SHALL SUPERSEDE ANY AND ALL SUBSEQUENT TERMS AND CONDITIONS WHICH MAY APPEAR ON ANY ATTACHED PRINTED DOCUMENTS SUCH AS PRICE LISTS, ORDER FORMS, SALES AGREEMENTS OR MAINTENANCE AGREEMENTS, INCLUDING ANY ELECTRONIC MEDIUM SUCH AS CD-ROM.</p> <p>REV. 01/17/2012</p> <p>EXHIBIT 4</p> <p>LOCAL GOVERNMENT BODIES: UNLESS THE VENDOR INDICATES IN THE BID HIS REFUSAL TO EXTEND THE PRICES, TERMS, AND CONDITIONS OF THE BID TO COUNTY, SCHOOL, MUNICIPAL AND OTHER LOCAL GOVERNMENT BODIES, THE BID SHALL EXTEND TO POLITICAL SUBDIVISIONS OF THE STATE OF WEST VIRGINIA. IF THE VENDOR DOES NOT WISH TO EXTEND THE PRICES, TERMS, AND CONDITIONS OF THE BID TO ALL POLITICAL SUBDIVISIONS OF THE STATE, THE VENDOR MUST CLEARLY INDICATE SUCH REFUSAL IN HIS BID. SUCH REFUSAL SHALL NOT PREJUDICE THE AWARD OF THIS CONTRACT IN ANY MANNER.</p> <p>PURCHASING CARD ACCEPTANCE: THE STATE OF WEST VIRGINIA CURRENTLY UTILIZES A VISA PURCHASING CARD PROGRAM WHICH IS ISSUED THROUGH A BANK. THE SUCCESSFUL VENDOR MUST ACCEPT THE STATE OF WEST VIRGINIA VISA PURCHASING CARD FOR PAYMENT OF ALL ORDERS PLACED BY ANY STATE</p>						

SEE REVERSE SIDE FOR TERMS AND CONDITIONS

SIGNATURE <i>Jim Wolford</i>	TELEPHONE (336) 475-6600	DATE 04/04/2012
TITLE Customer Sales & Support Manager	FEIN 56-1736552	ADDRESS CHANGES TO BE NOTED ABOVE

WHEN RESPONDING TO RFQ, INSERT NAME AND ADDRESS IN SPACE ABOVE LABELED 'VENDOR'



State of West Virginia
 Department of Administration
 Purchasing Division
 2019 Washington Street East
 Post Office Box 50130
 Charleston, WV 25305-0130

Request for Quotation

RFQ NUMBER
8512C2034

PAGE
4

ADDRESS CORRESPONDENCE TO ATTENTION OF:
ALAN CUMMINGS 304-558-2402

RFQ COPY
 TYPE NAME/ADDRESS HERE

VENDOR

SHIP TO

DIVISION OF HIGHWAYS
 VARIOUS LOCALES AS INDICATED
 BY ORDER

DATE PRINTED	TERMS OF SALE	SHIP VIA	F.O.B.	FREIGHT TERMS
03/25/2012				

BID OPENING DATE: 04/11/2012 BID OPENING TIME 01:30PM

LINE	QUANTITY	UOP	CAT. NO.	ITEM NUMBER	UNIT PRICE	AMOUNT
<p>AGENCY AS A CONDITION OF AWARD.</p> <p style="text-align: center;">NOTICE</p> <p>A SIGNED BID MUST BE SUBMITTED TO:</p> <p style="margin-left: 40px;">DEPARTMENT OF ADMINISTRATION PURCHASING DIVISION BUILDING 15 2019 WASHINGTON STREET, EAST CHARLESTON, WV 25305-0130</p> <p>THE BID SHOULD CONTAIN THIS INFORMATION ON THE FACE OF THE ENVELOPE OR THE BID MAY NOT BE CONSIDERED:</p> <p>SEALED BID</p> <p>BUYER: ALAN CUMMINGS - FILE 33</p> <p>RFQ. NO.: 8512C2034</p> <p>BID OPENING DATE: 04/11/2012</p> <p>BID OPENING TIME: 1:30 P.M.</p> <p>PLEASE PROVIDE A FAX NUMBER IN CASE IT IS NECESSARY TO CONTACT YOU REGARDING YOUR BID: (336) 475-7900</p> <p style="text-align: center;">-----</p>						

SEE REVERSE SIDE FOR TERMS AND CONDITIONS

SIGNATURE <i>Jim Montoya</i>	TELEPHONE (336) 475-6600	DATE 04/04/2012
TITLE Customer Sales & Support Manager	FEBIN 56-1736552	ADDRESS CHANGES TO BE NOTED ABOVE

WHEN RESPONDING TO RFQ, INSERT NAME AND ADDRESS IN SPACE ABOVE LABELED 'VENDOR'



State of West Virginia
 Department of Administration
 Purchasing Division
 2019 Washington Street East
 Post Office Box 50130
 Charleston, WV 25305-0130

Request for Quotation

RFQ NUMBER
8512C2034

PAGE
5

ADDRESS CORRESPONDENCE TO ATTENTION OF:
ALAN CUMMINGS 304-558-2402

RFQ COPY
 TYPE NAME/ADDRESS HERE

VENDOR

DIVISION OF HIGHWAYS
 VARIOUS LOCALES AS INDICATED
 BY ORDER

SHIP TO

DATE PRINTED	TERMS OF SALE	SHIP VIA	F.O.B.	FREIGHT TERMS
03/25/2012				

BID OPENING DATE: 04/11/2012 BID OPENING TIME 01:30PM

LINE	QUANTITY	UOP	CAT. NO.	ITEM NUMBER	UNIT PRICE	AMOUNT
CONTACT PERSON (PLEASE PRINT CLEARLY): ----- Jessica Townsend ----- ANY INDIVIDUAL SIGNING THIS BID IS CERTIFYING THAT: (1) HE OR SHE IS AUTHORIZED BY THE BIDDER TO EXECUTE THE BID OR ANY DOCUMENTS RELATED THERETO ON BEHALF OF THE BIDDER, (2) THAT HE OR SHE IS AUTHORIZED TO BIND THE BIDDER IN A CONTRACTUAL RELATIONSHIP, AND (3) THAT THE BIDDER HAS PROPERLY REGISTERED WITH ANY STATE AGENCIES THAT MAY REQUIRE REGISTRATION.						
***** THIS IS THE END OF RFQ 8512C2034 ***** TOTAL:						\$ 715,364.18

SEE REVERSE SIDE FOR TERMS AND CONDITIONS

SIGNATURE <i>Lin Wolfong</i>	TELEPHONE (336) 475-6600	DATE 04/04/2012
TITLE Customer Sales & Support Manager	FEIN 56-1736552	ADDRESS CHANGES TO BE NOTED ABOVE

WHEN RESPONDING TO RFQ, INSERT NAME AND ADDRESS IN SPACE ABOVE LABELED 'VENDOR'

RFQ#: 8512C2034

Specifications

Purpose:

The purpose of this Contract shall be to supply Type V, Category II, preformed retroreflective pavement marking materials and required application accessories to various West Virginia Division of Highways (WVDOH) locations, as noted herein. Preheating of the pavement surface, other than to remove moisture, prior to installation shall not be required with Category II material.

1.0 DEFINITIONS

- A. The "Agency" shall be defined as the West Virginia Division of Highways
- B. The "Vendor" shall be defined as the successful bidder.
- C. The "Purchase Order" shall be defined as the binding agreement that is entered into between the State of West Virginia and the Vendor to provide the services as herein specified.
- D. "Mandatory Requirements: The terms "must", "will", "shall", "minimum", "maximum", or "is/are required" identify a mandatory item or factor. Decisions regarding compliance with any mandatory requirements shall be at the sole discretion of the State.

2.0 SCOPE OF WORK

The successful Vendor shall provide:

The markings described are preformed, retroreflective pavement markings conforming in color, size and shape to the West Virginia Department of Transportation, Division of Highways' Standard Details Book, Vol. II, and to the Federal Highway Administration's Standard Alphabets for Highway Signs and Pavement Markings.

Preformed thermoplastic traffic markings shall be fabricated to a uniform thickness of not less than 125 mils, including retroreflective beads.

As a minimum, preformed thermoplastic traffic markings shall be capable of being applied to clean road surfaces at a minimum temperature of 35 degrees Fahrenheit (road surface and ambient air), with a surface primer if necessary, providing moisture has been sufficiently removed from the application surface. All retroreflectivity and durability requirements and

warranties shall conform to the specifications set forth in the West Virginia Division of Highways Standard Specifications roads and Bridges Adopted 2010.

3.0 TECHNICAL REQUIREMENTS

3.1 RETROREFLECTIVITY: Both white and yellow markings shall be warranted by the Manufacturer to maintain a minimum retroreflectivity level of 150 millicandelas, with beads applied, for the applicable warranty period as stated in section 4.0 of this RFQ.

All retroreflectivity measurements will be taken with a LTL 2000, or other Traffic Engineering Division approved 30-meter geometry retroreflectometer. A 5% tolerance with the stated minimum required retroreflectivity value shall be allowed when tested with a hand held retroreflectometer. Average retroreflectance values shall be determined by following an adequate sampling plan to be determined by the Division.

Generally, conformance of markings with the retroreflectivity requirement shall be based on a well dispersed sampling, to be determined by the Division, of the retroreflectivity over the whole marking. Retroreflectivity sampling may be concentrated on a specific area of the marking that appears to be in non-compliance with the Road Presence requirement for the purpose of determining non-compliance with quantitative data.

3.1.2 COLOR: Each color installed shall be warranted by the Manufacturer to fall within the boundaries created by the following CIE Chromaticity Coordinate Limits, with beads applied, for the applicable warranty period described above:

COLOR	CIE CHROMATICITY COORDINATE LIMITS							
	1		2		3		4	
	X	Y	X	Y	X	Y	X	Y
White	0.480	0.410	0.430	0.380	0.405	0.405	0.455	0.435
Yellow	0.575	0.425	0.508	0.415	0.473	0.453	0.510	0.490

The colormeter used shall be a LTL-Y, or other hand-held colormeter device approved by the Division. Average color coordinate values shall be determined by following an adequate sampling plan to be determined by the Division.

Generally, conformance of markings with the color requirements shall be based on a well dispersed sampling, to be determined by the Division, of the color values over the whole marking. Color sampling may be concentrated on a specific area of the marking that appears to be in non-compliance with the Road Presence requirement for the purpose of determining non-compliance with quantitative data.

3.1.3 ADHERENCE AND ROAD PRESENCE: Both white and yellow markings shall be warranted by the Manufacturer to maintain adherence and road presence for the applicable warranty period described above.

The Adherence and Road Presence requirement shall apply to materials worn uniformly, from the surface down, by normal traffic and snow-plowing. In addition, these requirements shall apply to materials at intersections subject to turning movements by normal traffic. However, these requirements shall not apply in cases of damage attributable to snow-plowing such as chiseling, cutting, chipping, or in cases of material removal from the roadway (other than removal from the surface down due to normal wearing as described above) when it can be shown that the material removal is due to snow-plowing rather than material adhesion failure. Loss due to pavement failure, unless caused by the marking material, will not be considered as a material failure.

3.1.4 ADDITIONAL SPECIFICATIONS FOR SKID RESISTANCE ENHANCED MATERIAL

Items indicated as being "Skid Resistance Enhanced" shall be specially manufactured to provide additional skid resistance above that which is provided by the other items listed on this Contract.

The material must have factory applied surface abrasives, wherein every other shaped portion contains glass beads, or abrasives with a minimum hardness of 7 (Mohs scale).

The surface of the preformed retroreflective marking materials, wherein every other shaped portion contains glass beads, or abrasives with a minimum hardness of 7 (Mohs scale), shall upon application provide a minimum skid resistance value of 60 BPN when tested according to ASTM: E 303.

3.1.5 ADDITIONAL SPECIFICATIONS FOR MANHOLE RINGS

The manhole protection rings included as part of this Contract shall meet the following specifications. The rings shall be in general conformance with the sample drawings shown immediately following these specifications:

1. USE: A durable material that is preformed for use as a manhole protection ring.

1.1 The material must be able to provide a durable sloped surface with a pitch more shallow than 1:12 to the edge of exposed manholes that vertically exceed the substrate surface.

1.2 The material must be a resilient black or grey thermoplastic product. The material must be resistant to the detrimental effects of motor fuels, lubricants, hydraulic fluids etc. The material must be capable of being affixed to bituminous and/or Portland cement concrete pavements by the use of the normal heat of a propane torch. Other colors shall be available as required.

1.3 The material must be capable of conforming to pavement contours, breaks and faults through the action of traffic at normal pavement temperatures. The material shall have resealing characteristics, such that it is capable of fusing with itself when heated with the torch.

1.4. The material must be able to be applied in temperatures down to 32°F without any special storage, preheating or treatment of the material before application.

2. MANUFACTURING CONTROL AND ISO CERTIFICATION:

The manufacturer must be ISO9002 certified and provide proof of current certification.

3.0 MATERIAL:

Must be composed of an ester-modified rosin resistant to degradation by motor fuels, lubricants etc. in conjunction with aggregates, pigments, and binders that have been factory produced as a finished product.

3.1. Heating indicators: The top surface of the material shall have regularly spaced indents. These indents shall act as a visual cue during application that the material has reached a molten state so satisfactory adhesion has been achieved and a post-application visual cue that the installation procedures have been followed.

3.2. Thickness: The material must be supplied at a minimum thickness of 125 mils (3.18 mm) per individual layer.

The material kit as provided by the manufacturer will provide minimum pre-applied vertical height adjustment of 125 mils (3.18mm) to 375 mils (9.53 mm).

3.3. Environmental Resistance: The material must be resistant to deterioration due to exposure to sunlight, water, salt or adverse weather conditions and impervious to oil and gasoline.

4.0 APPLICATION:

4.1. Asphalt: The materials shall be applied using the propane torch method recommended by the manufacturer.

The material must be able to be applied at ambient and road temperatures down to 32°F without any preheating of the pavement to a specific temperature. The material must be able to be applied without the use of a thermometer. The pavement shall be clean, dry and free of debris. Supplier must enclose application instructions with each box/package.

4.2. Portland Concrete: The same application procedure shall be used as described under Section 4.3 However; a compatible primer sealer may be applied before application to assure proper adhesion.

MANHOLE RING TYPICAL DRAWING

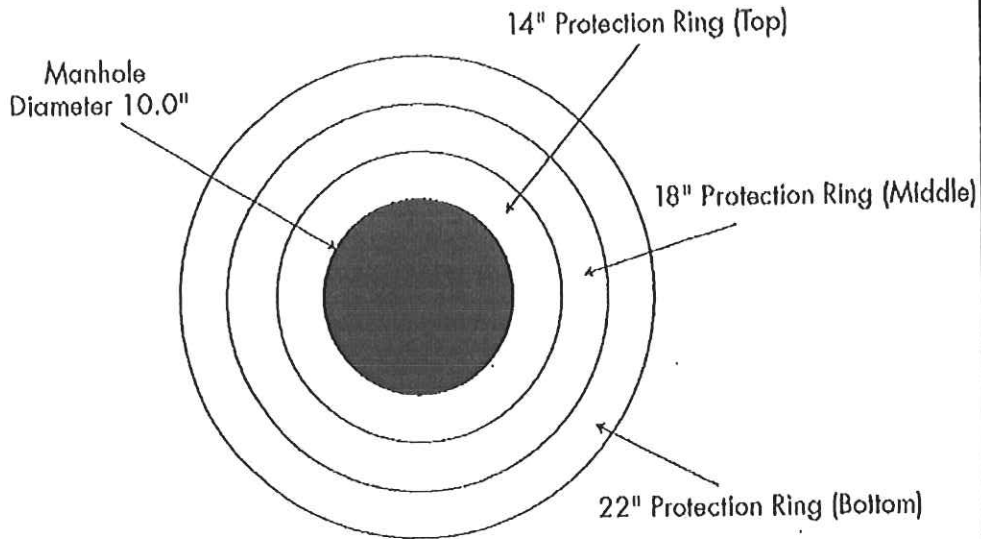

Manhole Protection Ring System

ITEM # 37

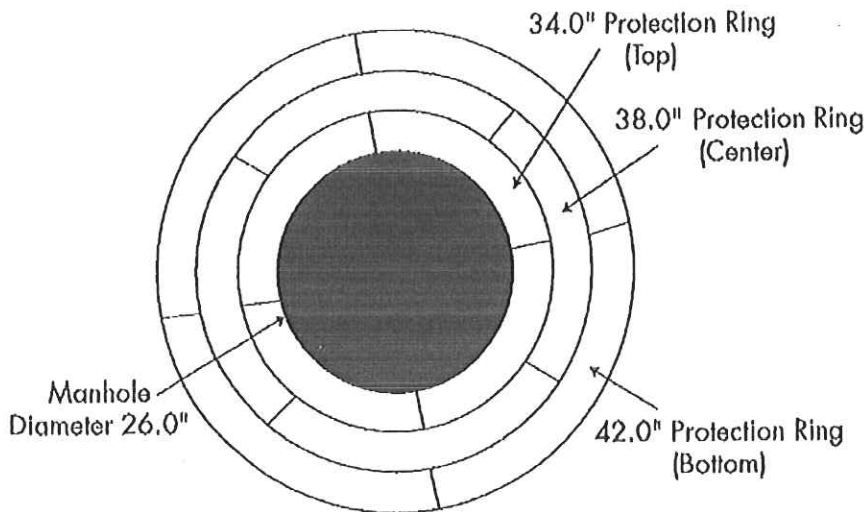

Manhole Protection Ring System

ITEM # 38

ITEMS 36, 39, AND 40 SIMILAR

4.0 MANUFACTURERS WARRANTY

Transverse markings shall be warranted by the Manufacturer to adhere to both asphalt and concrete, maintain road presence, and meet the retroreflectivity and color requirements described herein, for a minimum of three (3) years when applied according to the Manufacturer's recommendations. Transverse markings shall include stop bars, yield bar markings, legend, symbols such as lane assignment arrows and lane drop arrows, railroad crossing markings, crosswalk markings, stripes inside lane shunts and gore areas, and other similar markings.

Longitudinal lines shall be warranted by the Manufacturer to adhere to both asphalt and concrete, maintain road presence, and to meet the retroreflectivity and color requirements described herein, for a minimum of four (4) years when applied according to the Manufacturer's recommendations. Longitudinal lines shall include lane lines, barrier lines, channelizing lines, edge lines, and other similar markings.

If the material fails the adherence, road presence, color, or retroreflectivity requirements described above, the material shall be corrected by the Manufacturer in a manner acceptable to the Division at no additional cost to the Division. All warranty related work required shall be completed within sixty (60) calendar days of notification. The Manufacturer may, but shall not be required to replace preformed thermoplastic Type V material between December 1st and March 1st of the following year. Calendar Days falling within the time frames specified above will not be counted against the Manufacturer.

5.0 APPROVED PRODUCTS

Materials eligible to be bid for supply as part of this Contract shall meet the following requirements:

1. Reflective marking materials shall be included on the current WVDOH Approved Products List (APL) for Type V materials.
2. Reflective marking materials shall be a preformed thermoplastic requiring heat to melt and adhere the material to the road surface. Preformed tapes are not eligible.
3. Reflective marking materials, per the manufacturer's specifications and/or the application method under which the material was originally tested and approved by the WVDOH, shall not require pre-heating of the pavement surface to a specific temperature prior to applying the material.

Reflective marking materials approved for bidding on this Contract, based on the current Approved Products List, are as follows:

MANUFACTURER	MATERIAL
Flint Trading Company	Premark Plus White or Yellow
Flint Trading Company	Premark Plus Vizigrip White or Yellow

6.0 DELIVERY

The minimum State Contract Order (SCO) quantity for delivery to any specified destination shall not be less than \$1,000. The supplier shall be allowed fifteen (15) calendar days A.R.O. for delivery.

A minimum of forty-eight (48) hours prior to delivery, a documented telephone call shall be placed to the District at one of the numbers given within this contract document. First preference shall be the particular District's Sign Shop telephone number. If contact cannot be made at this number, second preference shall be the particular District's Headquarters. The vendor shall make it understood to the contact what is to be delivered and when. The vendor shall document who the contact was, and the time and date that the call was placed.

The WVDON shall assess liquidated damages against the supplier for each day that any delivery of material is delayed beyond the fifteen (15) day limit. The District may waive a portion or all of the liquidated damages at their discretion provided an ample supply of material is in stock at the District. The total amount of the liquidated damages shall be \$60 per calendar day per SCO and is in accordance with section 108.7 of the Standard Specifications.

7.0 TECHNICAL ASSISTANCE

The successful bidder shall provide the services of a qualified technician for instruction and training of WVDON personnel in each of the ten (10) District Sign Shops. These services shall be provided once to each District within one (1) week of notification by the Division and at no additional costs. In the event that this contract is renewed after one (1) year, the successful bidder shall again, if required, provide the above services to each of the District Sign Shops, as described above, during the initial renewal year and subsequent renewal years, at no additional costs.

BID SCHEDULE

The following estimated quantities are for bid purposes only. Actual quantities will be determined by needs of the West Virginia Division of Highways and may be increased or decreased.

ITEM NO.	ESTIMATED QUANTITY	UNIT OF MEASURE	DESCRIPTION	UNIT PRICE (PER PACKAGE)	TOTAL AMOUNT	INVENTORY SUBCODE (DOH USE ONLY)
1	100	EA (PACKAGE)	4 inch longitudinal line, white, 90 feet per package	\$ 100.44	\$ 10,044.00	540420 (INVENTORY UM IS PER PACKAGE)
2	50	EA (PACKAGE)	4 inch longitudinal line, yellow, 90 feet per package	\$ 106.58	\$ 5,329.00	560420 (INVENTORY UM IS PER PACKAGE)
3	10	EA (PACKAGE)	4 inch longitudinal line, blue, 90 feet per package	\$ 106.58	\$ 1,065.80	565420 (INVENTORY UM IS PER PACKAGE)
4	1	EA (PACKAGE)	4 inch SKID RESISTANCE ENCHANCED longitudinal line, blue, 90 feet per package (FOR CROSS HATCHING IN HANDICAPPED PARKING STALLS)	\$ 106.58	\$ 106.58	NA
5	25	EA (PACKAGE)	6 inch longitudinal line, white, 60 feet per package	\$ 100.44	\$ 2,511.00	540620 (INVENTORY UM IS PER PACKAGE)
6	1	EA (PACKAGE)	6 inch longitudinal line, black, 60 feet per package (BLACKOUT MATERIAL)	\$ 96.81	\$ 96.81	NA
7	1	EA (PACKAGE)	6 inch longitudinal line, grey, 60 feet per package (BLACKOUT MATERIAL)	\$ 96.81	\$ 96.81	NA
8	500	EA (PACKAGE)	8 inch longitudinal line, white, 45 feet per package	\$ 100.19	\$ 50,095.00	540820 (INVENTORY UM IS PER PACKAGE)
9	10	EA (PACKAGE)	8 inch longitudinal line, yellow, 45 feet per package	\$ 107.45	\$ 1,074.50	560820 (INVENTORY UM IS PER PACKAGE)
10	1500	EA (PACKAGE)	12 inch longitudinal line, white, 30 feet per package	\$ 100.63	\$ 150,945.00	541210 (INVENTORY UM IS PER PACKAGE)
11	300	EA (PACKAGE)	12 inch SKID RESISTANCE ENCHANCED longitudinal line, white, 30 feet per package	\$ 100.63	\$ 30,189.00	541211 (INVENTORY UM IS PER PACKAGE)
12	300	EA (PACKAGE)	12 inch longitudinal line, yellow, 30 feet per package	\$ 105.09	\$ 31,527.00	561210 (INVENTORY UM IS PER PACKAGE)
13	1	EA (PACKAGE)	12 inch longitudinal line, black, 30 feet per package (BLACKOUT MATERIAL)	\$ 96.81	\$ 96.81	NA
14	1	EA (PACKAGE)	12 inch longitudinal line, grey, 30 feet per package (BLACKOUT MATERIAL)	\$ 96.81	\$ 96.81	NA
15	100	EA (PACKAGE)	24 inch longitudinal line, white, 15 feet per package	\$ 100.56	\$ 10,056.00	512430 (INVENTORY UM IS PER PACKAGE)
16	50	EA (PACKAGE)	24 inch SKID RESISTANCE ENCHANCED longitudinal line, white, 15 feet per package	\$ 100.56	\$ 5,028.00	NA
17	150	EA (PACKAGE)	Straight Arrow 12" @ bottom of shaft, 3'-3" x 9'-10" 2 ea. per package **	\$ 180.73	\$ 27,109.50	555000 (INVENTORY UM IS PER PACKAGE)
18	900	EA (PACKAGE)	Curved Arrow, Left 12" @ bottom of shaft, 6'-3" x 8'-2" 2 ea. per package **	\$ 209.62	\$ 188,658.00	555011 (INVENTORY UM IS PER PACKAGE)

** NOTE ITEMS 15-18, 29-32, 35-39 - QTY INDICATED ON ORDER AND UNIT PRICE TO BE PER PACKAGE. ITEMS WITH INVENTORY SHOULD BE ENTERED INTO INVENTORY PER THE ESTABLISHED UNIT OF MEASURE NOTED IN THE SUBCODE COLUMN, WITH THE "UNIT PRICE" ADJUSTED ACCORDINGLY.

ITEM NO.	ESTIMATED QUANTITY	UNIT OF MEASURE	DESCRIPTION	UNIT PRICE (PER PACKAGE)	TOTAL AMOUNT	INVENTORY SUBCODE (DOH USE ONLY)
19	250	EA (PACKAGE)	Curved Arrow, Right 12" @ bottom of shaft, 6'-3" x 8'-2" 2 ea. per package **	\$ 209.62	\$ 52,405.00	555012 (INVENTORY UM IS)
20	100	EA (PACKAGE)	Curved Arrow, unbeaded 12" @ bottom of shaft, 6'-3" x 8'-2" 2 ea. per package **	\$ 209.62	\$ 20,962.00	555010 (INVENTORY UM IS)
21	50	EA (PACKAGE)	Combination Arrow 12" @ bottom of shaft, 7'-4" x 13'-1" 1 ea. per package SPECIFY RIGHT, LEFT, OR UNBEADED ON ORDER	\$ 189.60	\$ 9,480.00	555025 (INVENTORY UM IS)
22	200	EA (PACKAGE)	"ONLY" 6'-8" x 8'-0" 1 ea. per package	\$ 150.04	\$ 30,008.00	555050 (INVENTORY UM IS)
23	10	EA (PACKAGE)	"STOP" 7'-4" x 8'-0" 1 ea. per package	\$ 148.80	\$ 1,488.00	555040 (INVENTORY UM IS)
24	10	EA (PACKAGE)	"AHEAD" 8'-10" x 8'-0" 1 ea. per package	\$ 208.32	\$ 2,083.20	555060 (INVENTORY UM IS)
25	5	EA (PACKAGE)	"SCHOOL" 11'-4" X 8' 1 ea. per package FOR USE WHERE THE TEXT IS TO SPAN 1 LANE	\$ 233.55	\$ 1,167.75	555080 (INVENTORY UM IS)
26	5	EA (PACKAGE)	"SCHOOL" 14'-6" X 10' 1 ea. per package FOR USE WHERE THE TEXT IS TO SPAN 2 LANES	\$ 300.89	\$ 1,504.45	555081 (INVENTORY UM IS)
27	25	EA (PACKAGE)	Right side lane drop arrow (POINTS TO LEFT) 1 ea. per package	\$ 270.44	\$ 6,761.00	555015 (INVENTORY UM IS)
28	25	EA (PACKAGE)	Left side lane drop arrow (POINTS TO RIGHT) 1 ea. per package	\$ 270.44	\$ 6,761.00	555016 (INVENTORY UM IS)
29	10	EA (PACKAGE)	Unbeaded lane drop arrow 1 ea. per package	\$ 270.44	\$ 2,704.40	555017 (INVENTORY UM IS)
30	50	EA (PACKAGE)	Railroad Crossing (package) 2 ea. R's 12"x78" "X" 16" material, 20' height, 42" width 1 ea. per package	\$ 287.31	\$ 14,365.50	555030 (INVENTORY UM IS)

** NOTE ITEMS 15-18, 29-32, 35-39 - QTY INDICATED ON ORDER AND UNIT PRICE TO BE PER PACKAGE. ITEMS WITH INVENTORY SHOULD BE ENTERED INTO INVENTORY PER THE ESTABLISHED UNIT OF MEASURE NOTED IN THE SUBCODE COLUMN, WITH THE "UNIT PRICE" ADJUSTED ACCORDINGLY.

ITEM NO.	ESTIMATED QUANTITY	UNIT OF MEASURE	DESCRIPTION	UNIT PRICE (PER PACKAGE)	TOTAL AMOUNT	INVENTORY SUBCODE (DOH USE ONLY)
31	10	EA (PACKAGE)	White Handicap symbol with blue background, 48" square 2 ea. per package **	\$ 198.96	\$ 1,989.60	555100 (INVENTORY UM IS)
32	100	EA (PACKAGE)	Yield Line triangle Triangles to be 24"x36" 10 ea. per package **	\$ 128.84	\$ 12,884.00	555075 (INVENTORY UM IS)
33	25	EA (PACKAGE)	Freeway Ramp Wrong Way Arrow 8" wide material 2 ea. per package **	\$ 205.22	\$ 5,130.50	NA
34	25	EA (PACKAGE)	SKID RESISTANCE ENCHANCED Bicycle with rider and helmet symbol, 24" x 48". Bicycle to point to left 5 ea. per package **	\$ 324.38	\$ 8,109.50	555090 (INVENTORY UM IS)
35	100	EA	Primer, one (1) gallon container Approx. coverage of one gallon container to be 150 SF.	\$ 41.90	\$ 4,190.00	000015 (INVENTORY UM IS)
36	5	EA	Heat gun kit, complete (does not include LPG cylinder)	\$ 797.47	\$ 3,987.35	080815 Class 019 Type 008 (INVENTORY UM IS PER EA.)
37	100	EA (PACKAGE)	Super Bundy pad, 8 inch x 8 inch 80 ea. per package **	\$ 147.64	\$ 14,764.00	080108 Class 019 Type 008 (INVENTORY UM IS PER EA.)
38	1	EA (PACKAGE)	Manhole Protection Ring, 8" I.D. 2 ea. per package ** SPECIFY BLACK OR GREY ON ORDER	\$ 78.37	\$ 78.37	NA
39	1	EA (PACKAGE)	Manhole Protection Ring, 10" I.D. 2 ea. per package ** SPECIFY BLACK OR GREY ON ORDER	\$ 89.13	\$ 89.13	NA
40	1	EA (PACKAGE)	Manhole Protection Ring, 26" I.D. 2 ea. per package ** SPECIFY BLACK OR GREY ON ORDER	\$ 121.77	\$ 121.77	NA
41	1	EA (PACKAGE)	Manhole Protection Ring, 28" I.D. 2 ea. per package ** SPECIFY BLACK OR GREY ON ORDER	\$ 129.95	\$ 129.95	NA
42	1	EA (PACKAGE)	Manhole Protection Ring, 32" I.D. 1 ea. per package SPECIFY BLACK OR GREY ON ORDER	\$ 74.09	\$ 74.09	NA
TOTAL FOR ALL ITEMS					\$ 715,364.18	

** NOTE ITEMS 15-18, 29-32, 35-39 - QTY INDICATED ON ORDER AND UNIT PRICE TO BE PER PACKAGE. ITEMS WITH INVENTORY SHOULD BE ENTERED INTO INVENTORY PER THE ESTABLISHED UNIT OF MEASURE NOTED IN THE SUBCODE COLUMN, WITH THE "UNIT PRICE" ADJUSTED ACCORDINGLY.

The Traffic Engineering Division has established an online form in order for District personnel to submit a documented report to the Traffic Engineering Division regarding issues associated with material orders. This form is intended to serve as a manner in which District personnel may quickly and easily submit a documented report to the Traffic Engineering Division regarding issues associated with the ordering, delivery and receipt of materials ordered, quality issues with any of the materials received, and any issues associated with the reconciliation of orders. This form may also be used to report issues with the installation or post-installation performance of materials. This form is located in the "Traffic" section of the WVDOT intranet site (Click on "Traffic" on the left side of the page, then click on "PO Contract Report" on the left side of the page). The direct address for the location of this form is <http://sharepoint.wv.gov/sites/dot/highways/traffic/pocontractreport/Pages/default.aspx>. All reports submitted will be responded to by the Traffic Engineering Division. The Traffic Engineering Division will work with the individual at the District submitting the report to obtain additional needed facts or documentation such as photos or product samples, and will contact and work with the Contract Vendor and Materials Division if needed in order to reconcile the issues in a manner acceptable to all parties if possible. Typically, as a final step to address reported issues, the Traffic Engineering Division will complete and submit a WV-82 Vendor Performance Form in order to officially document any issues and their outcome. Once the report is submitted, an email verification will be automatically sent and an email notice will be sent to the Traffic Engineering Division. The initial point of contact for any submitted reports is Bruce Miller. If you have any questions or would like to follow up on the status of a report that has been submitted, please contact Mr. Miller at 558-9454 or bruce.f.miller@wv.gov.



CERTIFICATE OF APPROVAL

This is to certify that the Quality Management System of:

**Flint Trading, Inc.
Thomasville, North Carolina, USA**

has been approved by Lloyd's Register Quality Assurance
to the following Quality Management System Standards:

ISO 9001:2008

The Quality Management System is applicable to:

Design, Development and Manufacture of Preformed Extruded Thermoplastic Materials including: Retro reflective/reflective Skid Resistant Preformed Pavement Marking Materials, Skid Resistant Preformed Pavement Marking Materials, Skid Resistant Preformed Interconnected Pavement Marking Materials, Retro Reflective Profile Skid Resistant Preformed Thermoplastic Pavement Marking Materials, Retro Reflective Profile Preformed Thermoplastic Pavement Marking Materials, Preformed Thermoplastic Adhesive Materials, Preformed Detectable Materials.

Approval
Certificate No: UQA 0113270

Original Approval: January 19, 2004

Current Certificate: January 1, 2010

Certificate Expiry: December 31, 2012

Issued by: Lloyd's Register Quality Assurance, Inc.



This document is subject to the provision on the reverse
1401 Enclave Parkway, Suite 200, Houston, Texas 77077, USA
This approval is carried out in accordance with the LRQA assessment and certification procedures and monitored by LRQA.
Macro Revision 13

VENDOR PREFERENCE CERTIFICATE

Certification and application* is hereby made for Preference in accordance with *West Virginia Code*, §5A-3-37. (Does not apply to construction contracts). *West Virginia Code*, §5A-3-37, provides an opportunity for qualifying vendors to request (at the time of bid) preference for their residency status. Such preference is an evaluation method only and will be applied only to the cost bid in accordance with the *West Virginia Code*. This certificate for application is to be used to request such preference. The Purchasing Division will make the determination of the Resident Vendor Preference, if applicable.

1. **Application is made for 2.5% resident vendor preference for the reason checked:**
N/A Bidder is an individual resident vendor and has resided continuously in West Virginia for four (4) years immediately preceding the date of this certification; or,
N/A Bidder is a partnership, association or corporation resident vendor and has maintained its headquarters or principal place of business continuously in West Virginia for four (4) years immediately preceding the date of this certification; or 80% of the ownership interest of Bidder is held by another individual, partnership, association or corporation resident vendor who has maintained its headquarters or principal place of business continuously in West Virginia for four (4) years immediately preceding the date of this certification; or,
N/A Bidder is a nonresident vendor which has an affiliate or subsidiary which employs a minimum of one hundred state residents and which has maintained its headquarters or principal place of business within West Virginia continuously for the four (4) years immediately preceding the date of this certification; or,
2. **Application is made for 2.5% resident vendor preference for the reason checked:**
N/A Bidder is a resident vendor who certifies that, during the life of the contract, on average at least 75% of the employees working on the project being bid are residents of West Virginia who have resided in the state continuously for the two years immediately preceding submission of this bid; or,
3. **Application is made for 2.5% resident vendor preference for the reason checked:**
N/A Bidder is a nonresident vendor employing a minimum of one hundred state residents or is a nonresident vendor with an affiliate or subsidiary which maintains its headquarters or principal place of business within West Virginia employing a minimum of one hundred state residents who certifies that, during the life of the contract, on average at least 75% of the employees or Bidder's affiliate's or subsidiary's employees are residents of West Virginia who have resided in the state continuously for the two years immediately preceding submission of this bid; or,
4. **Application is made for 5% resident vendor preference for the reason checked:**
N/A Bidder meets either the requirement of both subdivisions (1) and (2) or subdivision (1) and (3) as stated above; or,
5. **Application is made for 3.5% resident vendor preference who is a veteran for the reason checked:**
N/A Bidder is an individual resident vendor who is a veteran of the United States armed forces, the reserves or the National Guard and has resided in West Virginia continuously for the four years immediately preceding the date on which the bid is submitted; or,
6. **Application is made for 3.5% resident vendor preference who is a veteran for the reason checked:**
N/A Bidder is a resident vendor who is a veteran of the United States armed forces, the reserves or the National Guard, if, for purposes of producing or distributing the commodities or completing the project which is the subject of the vendor's bid and continuously over the entire term of the project, on average at least seventy-five percent of the vendor's employees are residents of West Virginia who have resided in the state continuously for the two immediately preceding years.

Bidder understands if the Secretary of Revenue determines that a Bidder receiving preference has failed to continue to meet the requirements for such preference, the Secretary may order the Director of Purchasing to: (a) reject the bid; or (b) assess a penalty against such Bidder in an amount not to exceed 5% of the bid amount and that such penalty will be paid to the contracting agency or deducted from any unpaid balance on the contract or purchase order.

By submission of this certificate, Bidder agrees to disclose any reasonably requested information to the Purchasing Division and authorizes the Department of Revenue to disclose to the Director of Purchasing appropriate information verifying that Bidder has paid the required business taxes, provided that such information does not contain the amounts of taxes paid nor any other information deemed by the Tax Commissioner to be confidential.

Under penalty of law for false swearing (*West Virginia Code*, §61-5-3), Bidder hereby certifies that this certificate is true and accurate in all respects; and that if a contract is issued to Bidder and if anything contained within this certificate changes during the term of the contract, Bidder will notify the Purchasing Division in writing immediately.

Bidder: Flint Trading, Inc.

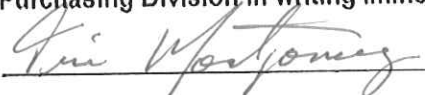
Signed: 

Date: 04/04/2012

Title: Customer Sales & Support Manager

*Check any combination of preference consideration(s) indicated above, which you are entitled to receive.

STATE OF WEST VIRGINIA
Purchasing Division

PURCHASING AFFIDAVIT

West Virginia Code §5A-3-10a states: No contract or renewal of any contract may be awarded by the state or any of its political subdivisions to any vendor or prospective vendor when the vendor or prospective vendor or a related party to the vendor or prospective vendor is a debtor and the debt owed is an amount greater than one thousand dollars in the aggregate.

DEFINITIONS:

"Debt" means any assessment, premium, penalty, fine, tax or other amount of money owed to the state or any of its political subdivisions because of a judgment, fine, permit violation, license assessment, defaulted workers' compensation premium, penalty or other assessment presently delinquent or due and required to be paid to the state or any of its political subdivisions, including any interest or additional penalties accrued thereon.

"Debtor" means any individual, corporation, partnership, association, limited liability company or any other form or business association owing a debt to the state or any of its political subdivisions. "Political subdivision" means any county commission; municipality; county board of education; any instrumentally established by a county or municipality; any separate corporation or instrumentally established by one or more counties or municipalities, as permitted by law; or any public body charged by law with the performance of a government function or whose jurisdiction is coextensive with one or more counties or municipalities. "Related party" means a party, whether an individual, corporation, partnership, association, limited liability company or any other form or business association or other entity whatsoever, related to any vendor by blood, marriage, ownership or contract through which the party has a relationship of ownership or other interest with the vendor so that the party will actually or by effect receive or control a portion of the benefit, profit or other consideration from performance of a vendor contract with the party receiving an amount that meets or exceeds five percent of the total contract amount.

EXCEPTION: The prohibition of this section does not apply where a vendor has contested any tax administered pursuant to chapter eleven of this code, workers' compensation premium, permit fee or environmental fee or assessment and the matter has not become final or where the vendor has entered into a payment plan or agreement and the vendor is not in default of any of the provisions of such plan or agreement.

Under penalty of law for false swearing (*West Virginia Code §61-5-3*), it is hereby certified that the vendor affirms and acknowledges the information in this affidavit and is in compliance with the requirements as stated.

WITNESS THE FOLLOWING SIGNATURE

Vendor's Name: Flint Trading, Inc.

Authorized Signature: *Gini Montjoy* Date: 04/04/2012

State of North Carolina

County of Davidson, to-wit:

Taken, subscribed, and sworn to before me this 4 day of April, 2012.

My Commission expires November 3, 2016.

AFFIX SEAL HERE

NOTARY PUBLIC. *Jennifer Beck*

