



State of West Virginia  
 Department of Administration  
 Purchasing Division  
 2019 Washington Street East  
 Post Office Box 50130  
 Charleston, WV 25305-0130

# Request for Quotation

RFQ NUMBER
8512C2018

PAGE
1

ADDRESS CORRESPONDENCE TO ATTENTION OF
PAUL REYNOLDS 304-558-0468

RFQ COPY  
 TYPE NAME/ADDRESS HERE

Protection Services Inc.  
 635 Lucknow Road  
 Harrisburg, PA 17110

DIVISION OF HIGHWAYS  
 TRAFFIC ENGINEERING DIVISION  
 VARIOUS LOCALES AS INDICATED  
 BY ORDER

DATE PRINTED	TERMS OF SALE	SHIP VIA	F.O.B.	FREIGHT TERMS
08/16/2011				

BID OPENING DATE: 08/31/2011 BID OPENING TIME 01:30PM

LINE	QUANTITY	UOP	CAT. NO.	ITEM NUMBER	UNIT PRICE	AMOUNT
0001		EA		968-83		
SMART CUSHIONS, TRAFFIC WORK BARRIERS (STATIONARY)						
OPEN END CONTRACT						
<p>THE WEST VIRGINIA STATE PURCHASING DIVISION FOR THE AGENCY, THE WEST VIRGINIA DIVISION OF HIGHWAYS IS SOLICITING BIDS FOR AN OPEN END CONTRACT TO PROVIDE MATERIALS REQUIRED FOR THE MAINTENANCE, REPLACEMENT, OR, INSTALLATION OF WORK AREA PROTECTION/SCI PRODUCTS SMART CUSHION ATTENUATING SERVICES PER THE ATTACHED SPECIFICATIONS.</p> <p>TECHNICAL QUESTIONS CONCERNING THIS SOLICITATION MUST BE SUBMITTED IN WRITING TO PAUL REYNOLDS IN THE WEST VIRGINIA STATE PURCHASING DIVISION VIA MAIL AT THE ADDRESS SHOWN IN THE BODY OF THIS RFQ, VIA FAX AT 304-558-2596, OR VIA EMAIL AT PAUL.REYNOLDS@WV.GOV. DEADLINE FOR ALL TECHNICAL QUESTIONS IS 08/26/11, AT THE CLOSE OF BUSINESS. ANY TECHNICAL QUESTIONS RECEIVED WILL BE ANSWERED BY FORMAL ADDENDUM TO BE ISSUED BY THE PURCHASING DIVISION AFTER THE DEADLINE WAS LAPSED.</p> <p>EXHIBIT 2</p> <p>LIFE OF CONTRACT: THIS CONTRACT BECOMES EFFECTIVE UPON AWARD AND EXTENDS FOR A PERIOD OF ONE (1) YEAR OR UNTIL SUCH "REASONABLE TIME" THEREAFTER AS IS NECESSARY TO OBTAIN A NEW CONTRACT OR RENEW THE</p>						

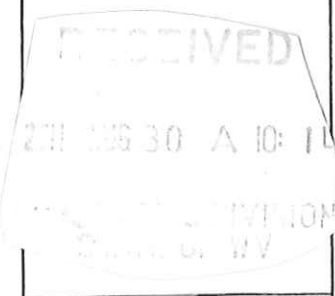

SEE REVERSE SIDE FOR TERMS AND CONDITIONS

SIGNATURE	TELEPHONE	DATE
<i>Paul Reynolds</i>	717-236-9307	8/29/11

TITLE	FEIN	ADDRESS CHANGES TO BE NOTED ABOVE
Vice President	23-2001976	

WHEN RESPONDING TO RFQ, INSERT NAME AND ADDRESS IN SPACE ABOVE LABELED 'VENDOR'

# GENERAL TERMS & CONDITIONS REQUEST FOR QUOTATION (RFQ) AND REQUEST FOR PROPOSAL (RFP)

1. Awards will be made in the best interest of the State of West Virginia.
  2. The State may accept or reject in part, or in whole, any bid.
  3. Prior to any award, the apparent successful vendor must be properly registered with the Purchasing Division and have paid the required \$125 fee.
  4. All services performed or goods delivered under State Purchase Order/Contracts are to be continued for the term of the Purchase Order/Contracts, contingent upon funds being appropriated by the Legislature or otherwise being made available. In the event funds are not appropriated or otherwise available for these services or goods this Purchase Order/Contract becomes void and of no effect after June 30.
  5. Payment may only be made after the delivery and acceptance of goods or services.
  6. Interest may be paid for late payment in accordance with the *West Virginia Code*.
  7. Vendor preference will be granted upon written request in accordance with the *West Virginia Code*.
  8. The State of West Virginia is exempt from federal and state taxes and will not pay or reimburse such taxes.
  9. The Director of Purchasing may cancel any Purchase Order/Contract upon 30 days written notice to the seller.
  10. The laws of the State of West Virginia and the *Legislative Rules* of the Purchasing Division shall govern the purchasing process.
  11. Any reference to automatic renewal is hereby deleted. The Contract may be renewed only upon mutual written agreement of the parties.
  12. **BANKRUPTCY:** In the event the vendor/contractor files for bankruptcy protection, the State may deem this contract null and void, and terminate such contract without further order.
  13. **HIPAA BUSINESS ASSOCIATE ADDENDUM:** The West Virginia State Government HIPAA Business Associate Addendum (BAA), approved by the Attorney General, is available online at [www.state.wv.us/admin/purchase/vrc/hipaa.htm](http://www.state.wv.us/admin/purchase/vrc/hipaa.htm) and is hereby made part of the agreement. Provided that the Agency meets the definition of a Cover Entity (45 CFR §160.103) and will be disclosing Protected Health Information (45 CFR §160.103) to the vendor.
  14. **CONFIDENTIALITY:** The vendor agrees that he or she will not disclose to anyone, directly or indirectly, any such personally identifiable information or other confidential information gained from the agency, unless the individual who is the subject of the information consents to the disclosure in writing or the disclosure is made pursuant to the agency's policies, procedures, and rules. Vendor further agrees to comply with the Confidentiality Policies and Information Security Accountability Requirements, set forth in <http://www.state.wv.us/admin/purchase/privacy/noticeConfidentiality.pdf>.
  15. **LICENSING:** Vendors must be licensed and in good standing in accordance with any and all state and local laws and requirements by any state or local agency of West Virginia, including, but not limited to, the West Virginia Secretary of State's Office, the West Virginia Tax Department, and the West Virginia Insurance Commission. The vendor must provide all necessary releases to obtain information to enable the director or spending unit to verify that the vendor is licensed and in good standing with the above entities.
  16. **ANTITRUST:** In submitting a bid to any agency for the State of West Virginia, the bidder offers and agrees that if the bid is accepted the bidder will convey, sell, assign or transfer to the State of West Virginia all rights, title and interest in and to all causes of action it may now or hereafter acquire under the antitrust laws of the United States and the State of West Virginia for price fixing and/or unreasonable restraints of trade relating to the particular commodities or services purchased or acquired by the State of West Virginia. Such assignment shall be made and become effective at the time the purchasing agency tenders the initial payment to the bidder.
- I certify that this bid is made without prior understanding, agreement, or connection with any corporation, firm, limited liability company, partnership, or person or entity submitting a bid for the same material, supplies, equipment or services and is in all respects fair and without collusion or fraud. I further certify that I am authorized to sign the certification on behalf of the bidder or this bid.

## INSTRUCTIONS TO BIDDERS

1. Use the quotation forms provided by the Purchasing Division. Complete all sections of the quotation form.
2. Items offered must be in compliance with the specifications. Any deviation from the specifications must be clearly indicated by the bidder. Alternates offered by the bidder as **EQUAL** to the specifications must be clearly defined. A bidder offering an alternate should attach complete specifications and literature to the bid. The Purchasing Division may waive minor deviations to specifications.
3. Unit prices shall prevail in case of discrepancy. All quotations are considered F.O.B. destination unless alternate shipping terms are clearly identified in the quotation.
4. All quotations must be delivered by the bidder to the office listed below prior to the date and time of the bid opening. Failure of the bidder to deliver the quotations on time will result in bid disqualifications: Department of Administration, Purchasing Division, 2019 Washington Street East, P.O. Box 50130, Charleston, WV 25305-0130
5. Communication during the solicitation, bid, evaluation or award periods, except through the Purchasing Division, is strictly prohibited (W.Va. C.S.R. §148-1-6.6).



State of West Virginia  
 Department of Administration  
 Purchasing Division  
 2019 Washington Street East  
 Post Office Box 50130  
 Charleston, WV 25305-0130

# Request for Quotation

RFQ NUMBER  
 8512C2018

PAGE  
 2

ADDRESS CORRESPONDENCE TO ATTENTION OF:  
 PAUL REYNOLDS  
 804-558-0468

**VENDOR**  
 RFQ COPY  
 TYPE NAME/ADDRESS HERE  
 Protection Services Inc.  
 635 Lucknow Road  
 Harrisburg, PA 17110

**SHIP TO**  
 DIVISION OF HIGHWAYS  
 TRAFFIC ENGINEERING DIVISION  
 VARIOUS LOCALES AS INDICATED  
 BY ORDER

DATE PRINTED	TERMS OF SALE	SHIP VIA	F.O.B	FREIGHT TERMS
08/16/2011				

BID OPENING DATE: 08/31/2011 BID OPENING TIME 01:30PM

LINE	QUANTITY	UOP	CAT NO.	ITEM NUMBER	UNIT PRICE	AMOUNT
<p>ORIGINAL CONTRACT. THE "REASONABLE TIME" PERIOD SHALL NOT EXCEED TWELVE (12) MONTHS. DURING THIS "REASONABLE TIME" THE VENDOR MAY TERMINATE THIS CONTRACT FOR ANY REASON UPON GIVING THE DIRECTOR OF PURCHASING THIRTY (30) DAYS WRITTEN NOTICE.</p> <p>UNLESS SPECIFIC PROVISIONS ARE STIPULATED IN THIS CONTRACT DOCUMENT, THE TERMS, CONDITIONS, AND PRICING SET HEREIN ARE FIRM FOR THE LIFE OF THE CONTRACT.</p> <p>RENEWAL: THIS CONTRACT MAY BE RENEWED UPON THE MUTUAL WRITTEN CONSENT OF THE SPENDING UNIT AND VENDOR, SUBMITTED TO THE DIRECTOR OF PURCHASING THIRTY (30) DAYS PRIOR TO THE EXPIRATION DATE. SUCH RENEWAL SHALL BE IN ACCORDANCE WITH THE TERMS AND CONDITIONS OF THE ORIGINAL CONTRACT AND SHALL BE LIMITED TO TWO (2) ONE (1) YEAR PERIODS.</p> <p>CANCELLATION: THE DIRECTOR OF PURCHASING RESERVES THE RIGHT TO CANCEL THIS CONTRACT IMMEDIATELY UPON WRITTEN NOTICE TO THE VENDOR IF THE COMMODITIES AND/OR SERVICES SUPPLIED ARE OF AN INFERIOR QUALITY OR DO NOT CONFORM WITH THE SPECIFICATIONS OF THE BID AND CONTRACT HEREIN.</p> <p>OPEN MARKET CLAUSE: THE DIRECTOR OF PURCHASING MAY AUTHORIZE A SPENDING UNIT TO PURCHASE ON THE OPEN MARKET, WITHOUT THE FILING OF A REQUISITION OR COST ESTIMATE, ITEMS SPECIFIED ON THIS CONTRACT FOR IMMEDIATE DELIVERY IN EMERGENCIES DUE TO UNFORESEEN CAUSES (INCLUDING BUT NOT LIMITED TO DELAYS IN TRANSPORTATION OR AN UNANTICIPATED INCREASE IN THE VOLUME OF WORK).</p> <p>QUANTITIES: QUANTITIES LISTED IN THE REQUISITION ARE APPROXIMATIONS ONLY, BASED ON ESTIMATES SUPPLIES BY THE STATE SPENDING UNIT. IT IS UNDERSTOOD AND AGREED THAT THE CONTRACT SHALL COVER THE QUANTITIES ACTUALLY</p>						

SEE REVERSE SIDE FOR TERMS AND CONDITIONS

SIGNATURE <i>Craig S. Hall</i>	TELEPHONE 717-236-9307	DATE 8/29/11
TITLE Vice President	FEIN 23-2001976	ADDRESS CHANGES TO BE NOTED ABOVE

WHEN RESPONDING TO RFQ, INSERT NAME AND ADDRESS IN SPACE ABOVE LABELED 'VENDOR'



State of West Virginia  
 Department of Administration  
 Purchasing Division  
 2019 Washington Street East  
 Post Office Box 50130  
 Charleston, WV 25305-0130

# Request for Quotation

RFQ NUMBER  
 8512C2018

PAGE  
 3

ADDRESS CORRESPONDENCE TO ATTENTION OF  
 PAUL REYNOLDS  
 304-558-0468

VENDOR

RFQ COPY  
 TYPE NAME/ADDRESS HERE  
 Protection Services Inc.  
 635 Lucknow Road  
 Harrisburg, PA 17110

SHIP TO

DIVISION OF HIGHWAYS  
 TRAFFIC ENGINEERING DIVISION  
 VARIOUS LOCALES AS INDICATED  
 BY ORDER

DATE PRINTED	TERMS OF SALE	SHIP VIA	FOB	FREIGHT TERMS
08/16/2011				

BID OPENING DATE: 08/31/2011 BID OPENING TIME 01:30PM

LINE	QUANTITY	UOP	CAT NO	ITEM NUMBER	UNIT PRICE	AMOUNT
<p>ORDERED FOR DELIVERY DURING THE TERM OF CONTRACT, WHETHER MORE OR LESS THAN THE QUANTITIES SHOWN.</p> <p>ORDERING PROCEDURE: SPENDING UNIT(S) SHALL ISSUE A WRITTEN EQUIPMENT CONTRACT ORDER (FORM NUMBER WV-35) FOR COMMODITIES COVERED BY THIS CONTRACT. THE ORIGINAL WV-35 MUST BE SENT TO THE PURCHASING DIVISION OF THE DEPARTMENT OF ADMINISTRATION. AFTER APPROVAL AND ENCUMBRANCE, ONE COPY OF THE PURCHASE ORDER WILL BE RETURNED TO THE SPENDING UNIT AND ONE COPY FORWARDED TO THE VENDOR AS AUTHORIZATION FOR SHIPMENT. NO ORDER IS VALID UNLESS APPROVED AND ENCUMBERED BY THE PURCHASING DIVISION.</p> <p>BANKRUPTCY: IN THE EVENT THE VENDOR/CONTRACTOR FILES FOR BANKRUPTCY PROTECTION, THE STATE MAY DEEM THE CONTRACT NULL AND VOID, AND TERMINATE SUCH CONTRACT WITHOUT FURTHER ORDER.</p> <p>REV. 5/2009</p> <p>PURCHASING CARD ACCEPTANCE: THE STATE OF WEST VIRGINIA CURRENTLY UTILIZES A VISA PURCHASING CARD PROGRAM WHICH IS ISSUED THROUGH A BANK. THE SUCCESSFUL VENDOR MUST ACCEPT THE STATE OF WEST VIRGINIA VISA PURCHASING CARD FOR PAYMENT OF ALL ORDERS PLACED BY ANY STATE AGENCY AS A CONDITION OF AWARD.</p> <p>EXHIBIT 4</p> <p>LOCAL GOVERNMENT BODIES: UNLESS THE VENDOR INDICATES IN THE BID HIS REFUSAL TO EXTEND THE PRICES, TERMS, AND CONDITIONS OF THE BID TO COUNTY, SCHOOL, MUNICIPAL</p>						

SEE REVERSE SIDE FOR TERMS AND CONDITIONS

SIGNATURE <i>Gregory S. Hill</i>	TELEPHONE 719-236-9307	DATE 8/29/11
TITLE Vice President	FEIN 23-2001976	ADDRESS CHANGES TO BE NOTED ABOVE

WHEN RESPONDING TO RFQ, INSERT NAME AND ADDRESS IN SPACE ABOVE LABELED 'VENDOR'



State of West Virginia  
 Department of Administration  
 Purchasing Division  
 2019 Washington Street East  
 Post Office Box 50130  
 Charleston, WV 25305-0130

# Request for Quotation

RFQ NUMBER  
 8512C2018

PAGE  
 4

ADDRESS CORRESPONDENCE TO ATTENTION OF:  
 PAUL REYNOLDS  
 304-558-0468

RFQ COPY  
 TYPE NAME/ADDRESS HERE

VENDOR

Protection Services Inc.  
 635 Lucknow Road  
 Harrisburg, PA 17110

SHIP TO

DIVISION OF HIGHWAYS  
 TRAFFIC ENGINEERING DIVISION  
 VARIOUS LOCALES AS INDICATED  
 BY ORDER

DATE PRINTED	TERMS OF SALE	SHIP VIA	F.O.B.	FREIGHT TERMS
08/16/2011				

BID OPENING DATE: 08/31/2011 BID OPENING TIME 01:30PM

LINE	QUANTITY	UOP	CAT. NO.	ITEM NUMBER	UNIT PRICE	AMOUNT
<p>AND OTHER LOCAL GOVERNMENT BODIES, THE BID SHALL EXTEND TO POLITICAL SUBDIVISIONS OF THE STATE OF WEST VIRGINIA. IF THE VENDOR DOES NOT WISH TO EXTEND THE PRICES, TERMS, AND CONDITIONS OF THE BID TO ALL POLITICAL SUBDIVISIONS OF THE STATE, THE VENDOR MUST CLEARLY INDICATE SUCH REFUSAL IN HIS BID. SUCH REFUSAL SHALL NOT PREJUDICE THE AWARD OF THIS CONTRACT IN ANY MANNER.</p> <p>REV. 3/88</p> <p style="text-align: center;">NOTICE</p> <p>A SIGNED BID MUST BE SUBMITTED TO:</p> <p style="text-align: center;">DEPARTMENT OF ADMINISTRATION          PURCHASING DIVISION          BUILDING 15          2019 WASHINGTON STREET, EAST          CHARLESTON, WV 25305-0130</p> <p>THE BID SHOULD CONTAIN THIS INFORMATION ON THE FACE OF THE ENVELOPE OR THE BID MAY NOT BE CONSIDERED:</p> <p>SEALED BID</p> <p>BUYER: PAUL REYNOLDS FILE 33</p> <p>RFQ. NO.: 8512C2018</p> <p>BID OPENING DATE: 08/31/2011</p> <p>BID OPENING TIME: 01:30 P.M.</p> <p>PLEASE PROVIDE A FAX NUMBER IN CASE IT IS NECESSARY TO CONTACT YOU REGARDING YOUR BID: FAX 217-236-1281</p>						

SEE REVERSE SIDE FOR TERMS AND CONDITIONS

SIGNATURE *Greg S. Hall* TELEPHONE 717-236-9307 DATE 8/29/11

TITLE Vice President FEIN 23-2001976 ADDRESS CHANGES TO BE NOTED ABOVE

WHEN RESPONDING TO RFQ, INSERT NAME AND ADDRESS IN SPACE ABOVE LABELED 'VENDOR'



State of West Virginia  
 Department of Administration  
 Purchasing Division  
 2019 Washington Street East  
 Post Office Box 50130  
 Charleston, WV 25305-0130

# Request for Quotation

RFQ NUMBER  
 8512C2018

PAGE  
 5

ADDRESS CORRESPONDENCE TO ATTENTION OF:  
 PAUL REYNOLDS  
 304-558-0468

VENDOR

RFQ COPY  
 TYPE NAME/ADDRESS HERE  
 Protection Services Inc.  
 635 Lucknow Road  
 Harrisburg, PA 17110

SHIP TO

DIVISION OF HIGHWAYS  
 TRAFFIC ENGINEERING DIVISION  
 VARIOUS LOCALES AS INDICATED  
 BY ORDER

DATE PRINTED	TERMS OF SALE	SHIP VIA	F.O.B	FREIGHT TERMS
08/16/2011				

BID OPENING DATE: 08/31/2011 BID OPENING TIME 01:30PM

LINE	QUANTITY	UOP	CAT. NO.	ITEM NUMBER	UNIT PRICE	AMOUNT
-----						
CONTACT PERSON (PLEASE PRINT CLEARLY):						
-----						
***** THIS IS THE END OF RFQ 8512C2018 ***** TOTAL: _____						

SEE REVERSE SIDE FOR TERMS AND CONDITIONS

SIGNATURE <i>Craig S. Hall</i>	TELEPHONE 717-236-9307	DATE 8/29/11
TITLE Vice President	FEIN 23-2001976	ADDRESS CHANGES TO BE NOTED ABOVE

WHEN RESPONDING TO RFQ, INSERT NAME AND ADDRESS IN SPACE ABOVE LABELED 'VENDOR'

## Specifications

Purpose: The purpose of this contract shall be to furnish materials required for the maintenance, replacement, or installation of Work Area Protection/SCI Products Smart Cushion attenuating devices.

### 1.0 DEFINITIONS

- A. The "Agency" shall be defined as the West Virginia Division of Highways
- B. The "Vendor" shall be defined as the successful bidder.
- C. The "Contract" shall be defined as the binding agreement that is entered into between the State of West Virginia and the Vendor to provide the services as herein specified.
- D. "Release Order" shall be defined as order placed against the Contract by the Agency.
- E. Mandatory Requirements: The terms "must", "will", "shall", "minimum", "maximum", or "is/are required" identify a mandatory item or factor. Decisions regarding compliance with any mandatory requirements shall be at the sole discretion of the State.

### 2.0 SCOPE OF WORK

Technical Requirements: The Vendor shall provide individual replacement components for Work Area Protection/SCI Products Smart Cushion attenuating devices. The Vendor shall also supply complete units upon request.

- 2.1 Complete descriptions of the individual parts are included as part of the bid schedule. The bid schedule also includes references to the appropriate manufacturer installation drawing, also included as part of this Contract for reference.

This Contract also includes items for the purchase of complete Smart Cushion units for use at the Agency's discretion.

#### 2.2 Freight

2.2.1 All shipments are to be FOB Destination.

2.2.2 The Vendor shall be responsible for all freight charges incurred as a result of the purchases under this Contract. For orders where expedited delivery is requested and authorized by the Agency, the Vendor may

invoice for these charges provided that it will be given as a "pass through" cost to the Agency. No markup shall be permitted for expedited delivery. See Section 3.2.3 for more information.

## 2.3 Delivery

2.3.1 This Contract may be utilized by multiple recipients statewide, each having a unique delivery address.

2.3.2 Release Orders shall be delivered in full within a maximum of twenty-one (21) Calendar Days ARO. If the Vendor is unable to deliver in full within twenty-one (21) Calendar Days, the Vendor shall be subject to a \$50.00 per Calendar Day penalty at the purchasing organization's discretion for each Calendar Day beyond twenty-one (21) Calendar Days ARO. This penalty shall be assessed by subtracting the penalty from the payment due to the Vendor upon full delivery of the Release Order.

2.3.3 All large components shall be shipped adequately secured on pallets for ease in unloading. Large components shall be easily identifiable or the packaging shall be labeled indicating the contained parts. All accessory hardware and relatively small components shall be appropriately packaged and labeled. Any material delivered not meeting the above requirements shall be subject to being returned to the Vendor at the Vendor's expense.

2.3.4 Delivery is an integral part of this contract and failure to comply will be cause to initiate a WV-82, Vendor Performance Form. This form will officially notify the West Virginia Division of Purchasing and the Vendor of unsatisfactory performance in the execution of this contract and the requirements herein.

## 3.0 ORDERING AND INVOICING

### 3.1 Release Orders

3.1.1 For all orders, the Agency will issue to the Vendor a WV-35 Release Order. Issuance of the Release Order shall contain the type of merchandise to be purchased and shall serve as the authorization to process the order.



### 3.2 Payment

3.2.1 The State of West Virginia currently utilizes a VISA purchasing card program which is issued through a local bank. The Vendor must accept the State of West Virginia purchasing card for payment of all orders placed against this Contract.

3.2.2 The Vendor must supply a credit card receipt, sales receipt, or cash register receipt. Charges must not be applied until merchandise is received in full by the Agency.

3.2.3 For orders where expedited delivery has been requested by the Agency per Section 2.2.2, the Vendor may add actual shipping costs (prepaid) to the invoice as a separate item. In this case, the Vendor shall attach a copy of the freight bill to the invoice sent to the Agency. All such orders shall be delivered in full within ten (10) Calendar Days ARO. If any such order is not received in full within ten (10) Calendar Days ARO, the Vendor may not add shipping costs as described above to the invoice and the order will be treated as a normal non-expedited order with the provisions of Section 2.3.2 to apply.

## 4.0 AWARD

### 4.1 Contract Sections

4.1.1 This Contract shall be awarded in its' entirety. The Vendor shall be required to provide a bid for all Items listed.

**BID SCHEDULE**

The following estimated quantities are for bid purposes only. Actual quantities will be determined by the needs of the West Virginia Division of Highways and may be increased or decreased:

ITEM NUMBER	ESTIMATED QUANTITY	DESCRIPTION	PART DETAIL SHEET(S)	COST	(DOH USE ONLY) INVENTORY SUBCODE
<b>NOTE: ITEMS 1 THROUGH 209 ARE NOT INCLUDED WITHIN THIS CONTRACT</b>					
<b>Work Area Protection/SCI Products Smart Cushion Attenuators</b>					
<b>Shear Bolts</b>					
210	1	Shear Bolt	NA	\$ 1.65	311100
<b>Side (fender) panels</b>					
211	1	Front sled side panel (to include keepers and any other required hardware for attachment)	63/64	\$ 532.40	312100
212	1	Intermediary side panel (to include keepers and any other required hardware for attachment) <b>DO NOT USE FOR SLED OR LAST BAY</b>	63/64	\$ 295.90	312150
213	1	Rear bay side panel (to include keepers and any other required hardware for attachment)	63/64	\$ 277.20	312200
<b>Mobile Frames (Diaphragms)</b>					
214	1	Mobile Frame #1 (1 <sup>st</sup> frame for TL-3 unit). To include side guides and any required hardware <b>DO NOT USE IN TL-2 UNIT</b>	63/64	\$ 662.20	NA
215	1	Mobile Frame #2 (2 <sup>nd</sup> frame for TL-3 unit). To include side guides and any required hardware <b>DO NOT USE IN TL-2 UNIT</b>	63/64	\$ 662.20	NA
216	1	Mobile Frame #3 (3 <sup>rd</sup> frame for TL-3 unit) To include side guides and any required hardware <b>DO NOT USE IN TL-2 UNIT</b>	63/64	\$ 662.20	NA
217	1	Mobile Frame #4 (4 <sup>th</sup> frame for TL-3 unit / 1 <sup>st</sup> frame for TL-2 unit) To include side guides and any required hardware	63/64	\$ 662.20	NA
218	1	Mobile Frame #5 (5 <sup>th</sup> frame for TL-3 unit / 2 <sup>nd</sup> frame for TL-2 unit) To include side guides and any required hardware	63/64	\$ 662.20	NA
219	1	Mobile Frame #6 (6 <sup>th</sup> frame for TL-3 unit / 3 <sup>rd</sup> frame for TL-2 unit) To include side guides and any required hardware	63/64	\$ 662.20	NA
<b>Front (nose) covers</b>					
220	1	Front cover panel, yellow -- TL-2 unit (for mounting reflective panel)	NA	\$ 88.00	314100
221	1	Front cover panel, yellow -- TL-3 unit (for mounting reflective panel)	NA	\$ 94.60	314150
<b>Front Sleds</b>					
222	1	Front sled -- TL-2 unit (to include guide rollers and any additional components / hardware required for installation)	63/64	\$2,108.70	NA
223	1	Front sled -- TL-3 unit (to include guide rollers and any additional components / hardware required for installation)	63/64	\$2,108.70	NA
<b>Sheave Tools/Components</b>					
224	1	Anti-rotation pin removal tool	NA	\$ 25.30	NA
225	1	Front sheave anti-rotation pin	NA	\$ 74.80	NA
226	1	Rear sheave anti-rotation pin	NA	\$ 74.80	NA
227	1	Sheave cover plate (to include attachment hardware)	NA	\$ 30.80	NA

		Transitions			
228	1	Right side jersey barrier transition (to include all required hardware excluding anchor bolts for complete installation)	65/66	\$1,389.30	NA
229	1	Left side jersey barrier transition (to include all required hardware excluding anchor bolts for complete installation)	65/66	\$1,389.30	NA
230	1	Right side 24" block transition (to include all required hardware excluding anchor bolts for complete installation)	67/68	\$ 873.40	NA
231	1	Left side 24" block transition (to include all required hardware excluding anchor bolts for complete installation)	67/68	\$ 873.40	NA
232	1	Right side 30" block straight transition panel (to include all required hardware excluding anchor bolts for complete installation)	69/70	\$2,816.00	NA
233	1	Left side 30" block straight transition panel (to include all required hardware excluding anchor bolts for complete installation)	69/70	\$2,816.00	NA
234	1	Right side 36" block straight transition panel (to include all required hardware excluding anchor bolts for complete installation)	71/72	\$4,972.00	NA
235	1	Left side 36" block straight transition panel (to include all required hardware excluding anchor bolts for complete installation)	71/72	\$4,972.00	NA
236	1	Right side SCI to thrie beam rail transition (to include hardware required for attaching first panel of transition to last SCI side panel)	73/74	\$1,197.90	NA
237	1	Left side SCI to thrie beam rail transition (to include hardware required for attaching first panel of transition to last SCI side panel)	73/74	\$1,197.90	NA
238	1	Right side SCI to w-beam rail transition (to include hardware required for attaching first panel of transition to last SCI side panel) To also include intermediary thrie beam transition	75/76	\$1,197.90	NA
239	1	Left side SCI to w-beam rail transition (to include hardware required for attaching first panel of transition to last SCI side panel) To also include intermediary thrie beam transition	75/76	\$1,197.90	NA
240	1	Right side straight slope barrier transition (to include all required hardware excluding anchor bolts for complete installation)	77/78	\$1,558.70	NA
241	1	Left side straight slope barrier transition (to include all required hardware excluding anchor bolts for complete installation)	77/78	\$1,558.70	NA
		Complete Units			
242	1	Work Area Protection/SCI Products Smart Cushion SCI70GM-CA unit, NCHRP-350 Test Level 2, 24" width, to be delivered pre-assembled (to include all anchoring studs and anchoring stud epoxy required for installation on concrete) THIS ITEM MAY ONLY BE ORDERED BY THE TRAFFIC ENGINEERING DIVISION	NA	\$17,270.00	NA
243	1	Work Area Protection/SCI Products Smart Cushion SCI100GM-CA unit, NCHRP-350 Test Level 3, 24" width, to be delivered pre-assembled (to include all anchoring studs and anchoring stud epoxy required for installation on concrete) THIS ITEM MAY ONLY BE ORDERED BY THE TRAFFIC ENGINEERING DIVISION	NA	\$22,220.00	NA

SMART CUSHION® by SCI Products Inc.

APPENDIX C - SMART CUSHION®, TEST LEVEL 2

- PARTS LIST**
- 01 - Front Sled
  - 02 - Cable Assembly
  - 05 - Sled Panel
  - 07 - Terminal Brace
  - 09 - Anchor Bolts
  - 12 - Side Panels
  - 14 - Mobile Sheave Assembly
  - 17 - Cable Adjuster Bolt
  - 18-20 - Mobile frames 4-6
  - 26 - Cylinder
  - 27 - Rear Panel
  - 06,08,29 - Side Keepers

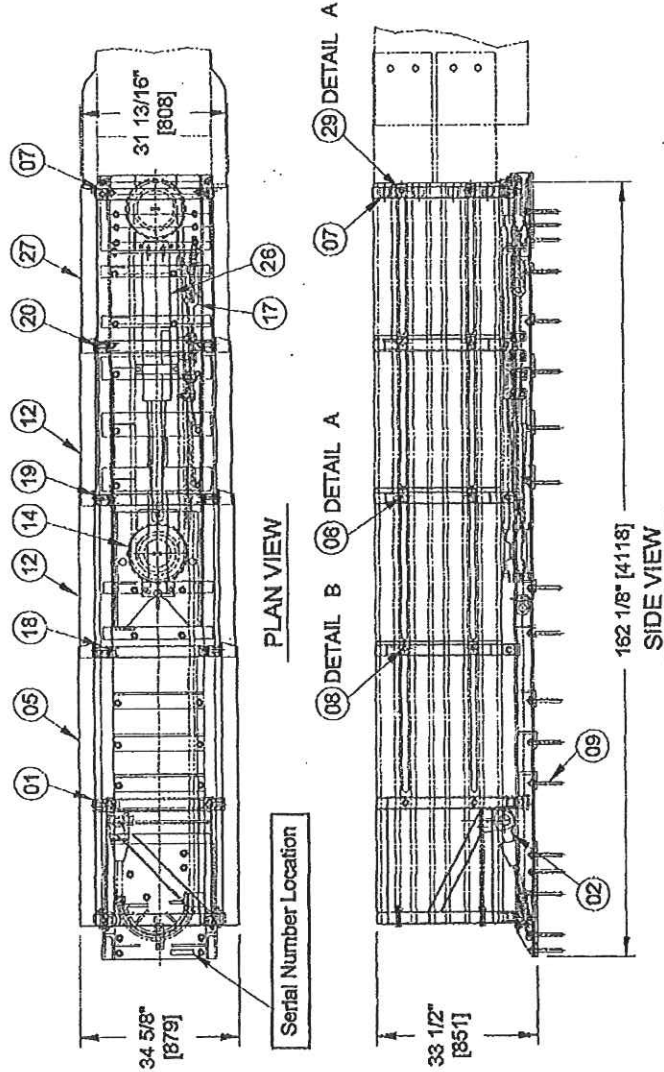
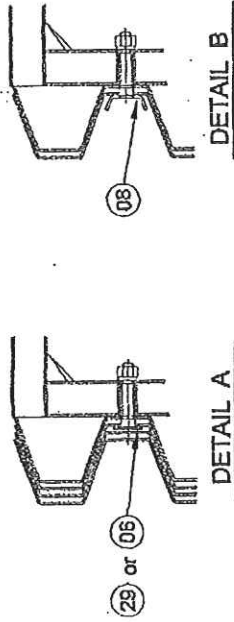

SMART CUSHION® by SCI Products Inc.

APPENDIX D - SMART CUSHION®, TEST LEVEL 3

PARTS LIST	
01	Front Sled
02	Cable Assembly
05	Sled Panel
07	Terminal Brace
09	Anchor Bolts
12	Side Panels
14	Mobile Sheave Assembly
17	Cable Adjuster Bolt
18-23	Mobile frames 1-6
26	Cylinder
27	Rear Panel
06,08,29	Side Keepers

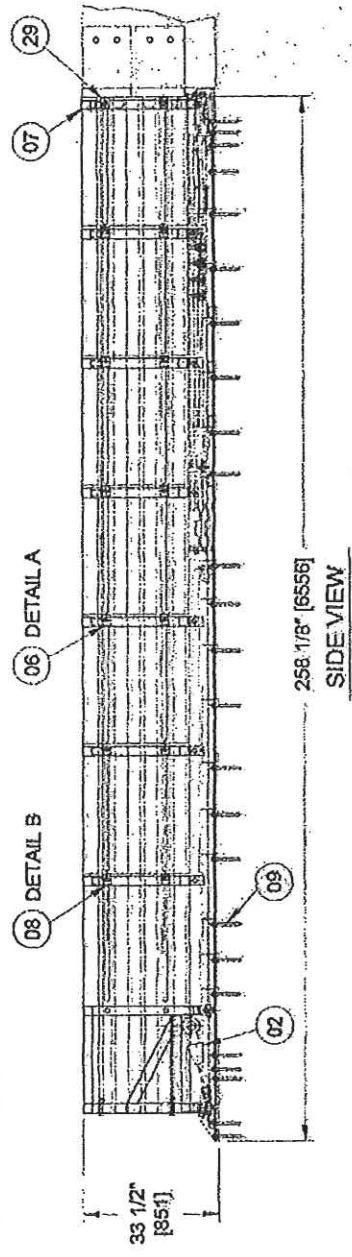
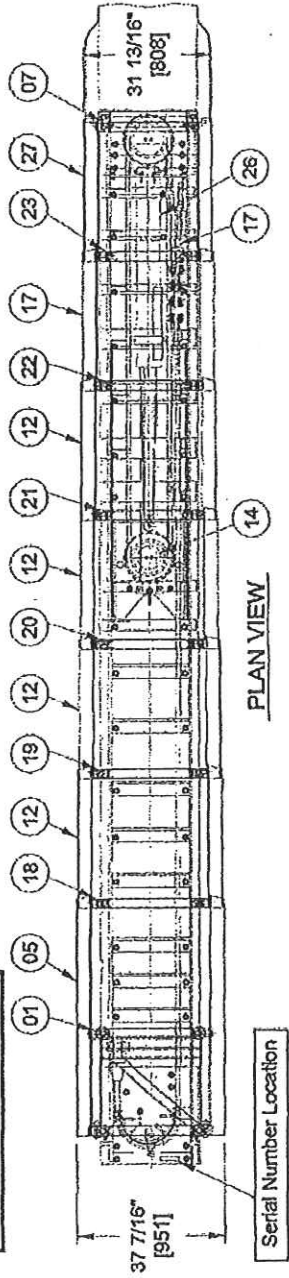
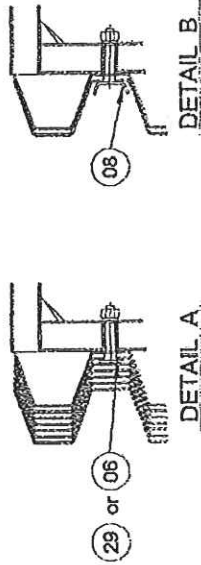

SMART CUSHION<sup>®</sup> by SCI Products Inc.

APPENDIX G - TRANSITION, JERSEY/F SHAPE BARRIER

- Parts List:  
01 - Transition Jersey Barrier Right #9431  
01 - Transition Jersey Barrier Left #9432

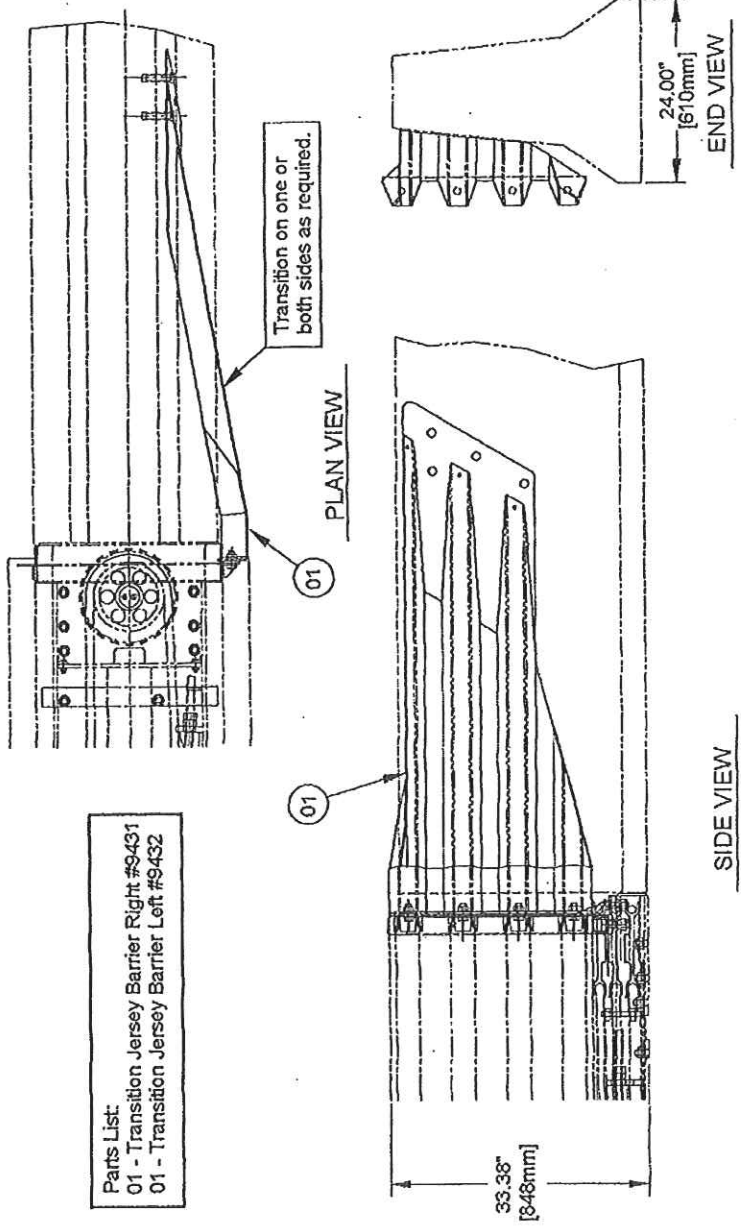

APPENDIX G(2) - TRANSITION, JERSEY/F SHAPE BARRIER

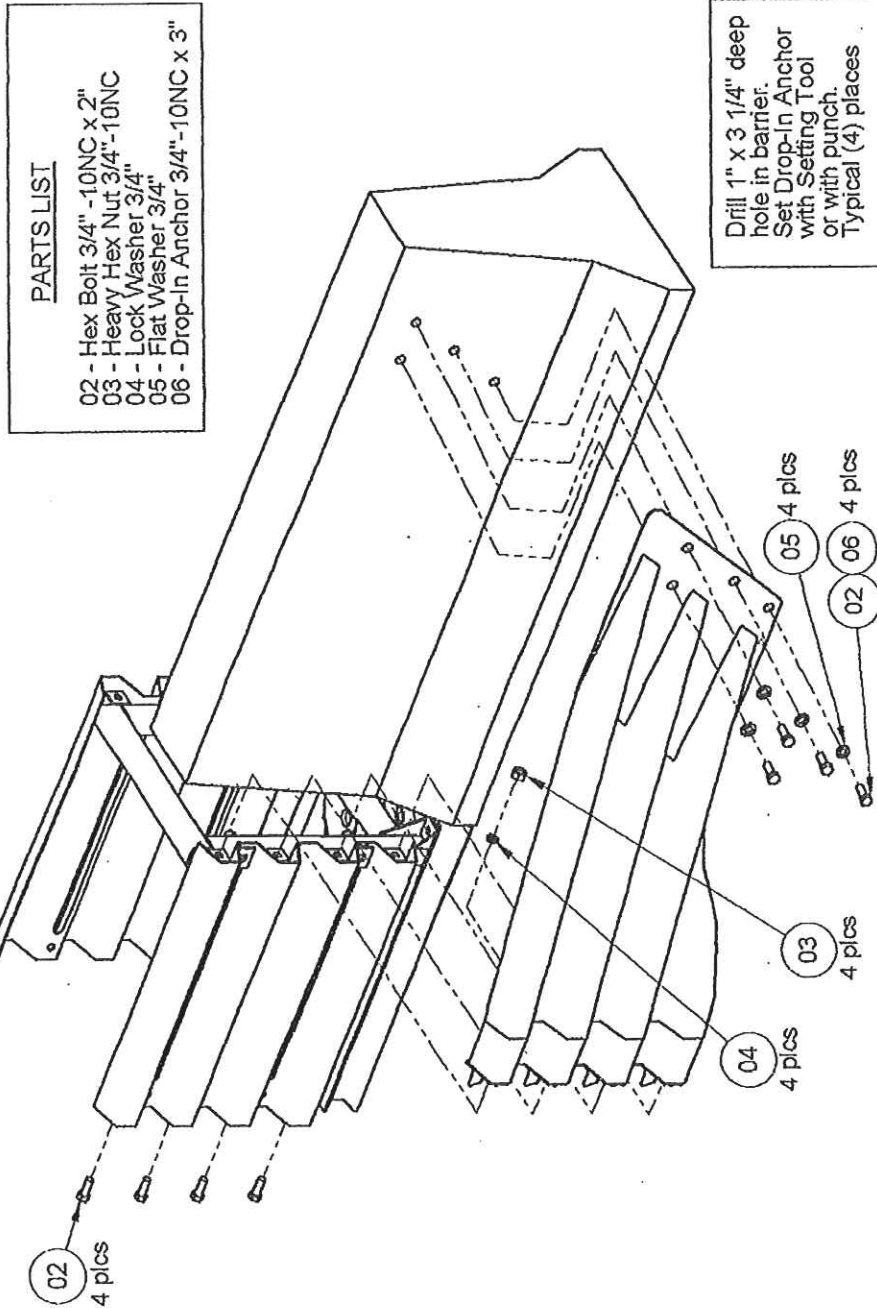

PARTS LIST

- 02 - Hex Bolt 3/4" - 10NC x 2"
- 03 - Heavy Hex Nut 3/4"-10NC
- 04 - Lock Washer 3/4"
- 05 - Flat Washer 3/4"
- 06 - Drop-In Anchor 3/4"-10NC x 3"

Drill 1" x 3 1/4" deep hole in barrier. Set Drop-In Anchor with Setting Tool or with punch. Typical (4) places

SMART CUSHION® by SCI Products Inc.

APPENDIX H - TRANSITION, CONCRETE BLOCK, 24 INCH (610mm)

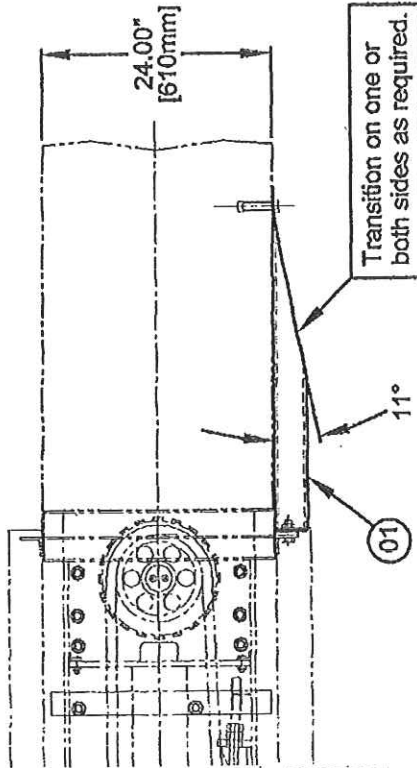

PLAN VIEW

Parts List:  
Transition 24" Concrete Block Right & Left #9433

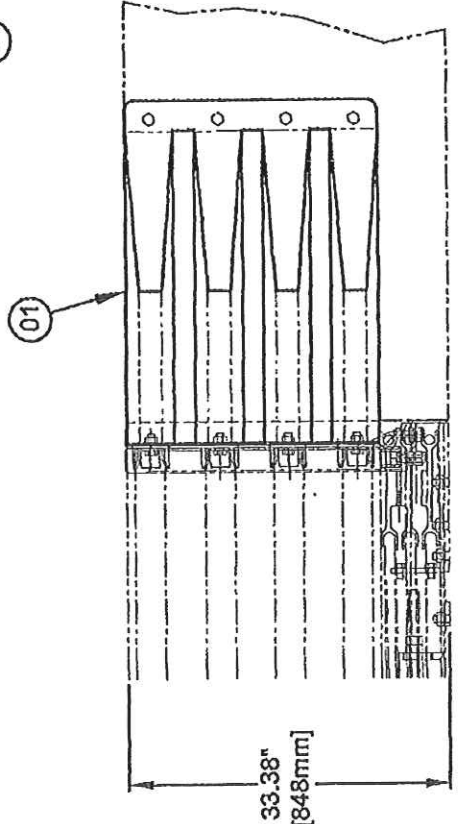

SIDE VIEW



APPENDIX H(2) - TRANSITION, CONCRETE BLOCK, 24 INCH (610mm)

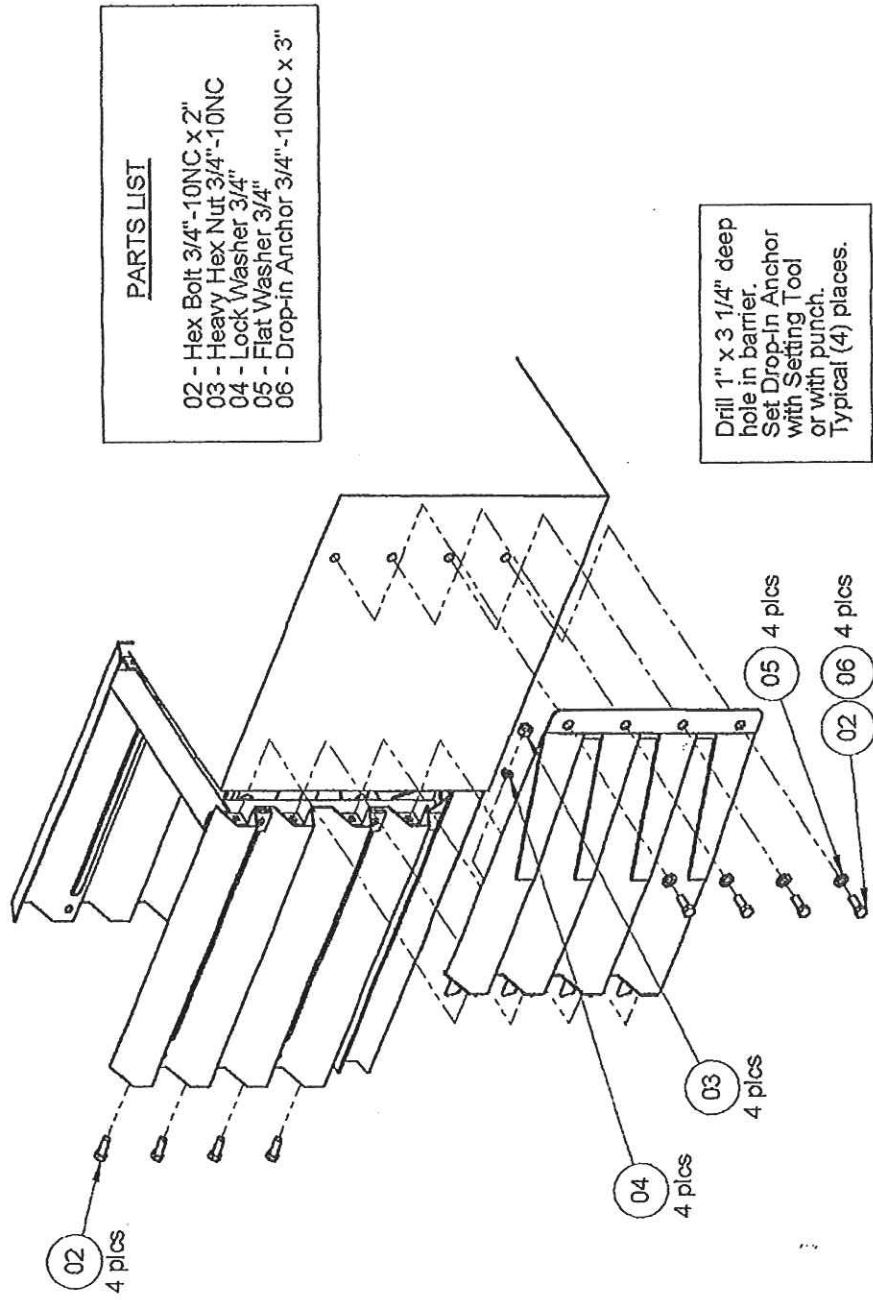

- PARTS LIST
- 02 - Hex Bolt 3/4" - 10NC x 2"
  - 03 - Heavy Hex Nut 3/4" - 10NC
  - 04 - Lock Washer 3/4"
  - 05 - Flat Washer 3/4"
  - 06 - Drop-In Anchor 3/4" - 10NC x 3"

Drill 1" x 3 1/4" deep hole in barrier.  
Set Drop-In Anchor with Setting Tool or with punch.  
Typical (4) places.

02 4 pics

04 4 pics

03 4 pics

05 4 pics

06 4 pics

SMART CUSHION® by SCI Products Inc.

APPENDIX I - TRANSITION, CONCRETE BLOCK, 30 INCH (762mm)

- Parts List:  
Two Sided Full Assembly #9459  
01-Transition 30" Concrete Straight Connection #9463  
02-Transition Concrete Spanner Brace #9469

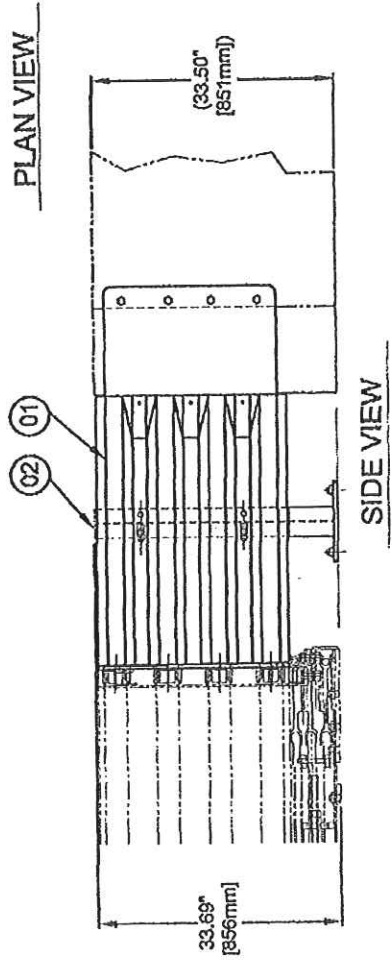
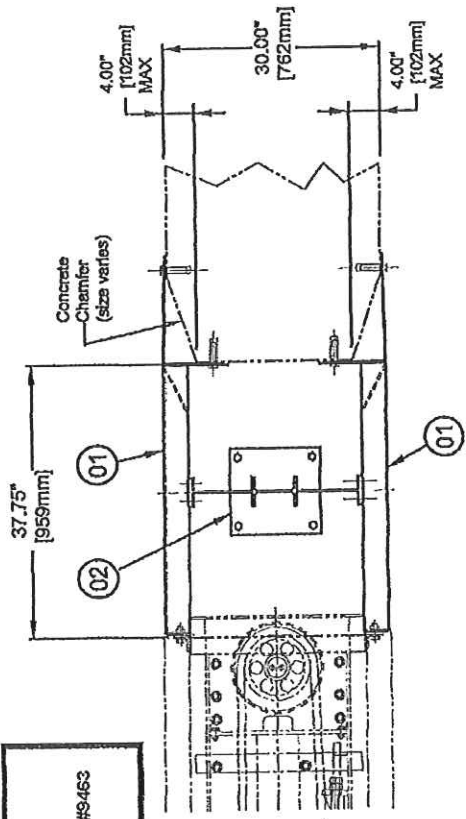

USED FOR:  
1. Unchamfered Concrete Block \*\*\*  
2. Chamfered Concrete Block \*\*\*  
\*\*\*Chamfer limited to <4"\*\*\*

APPENDIX I(2) - TRANSITION, CONCRETE BLOCK, 30 INCH (762mm)

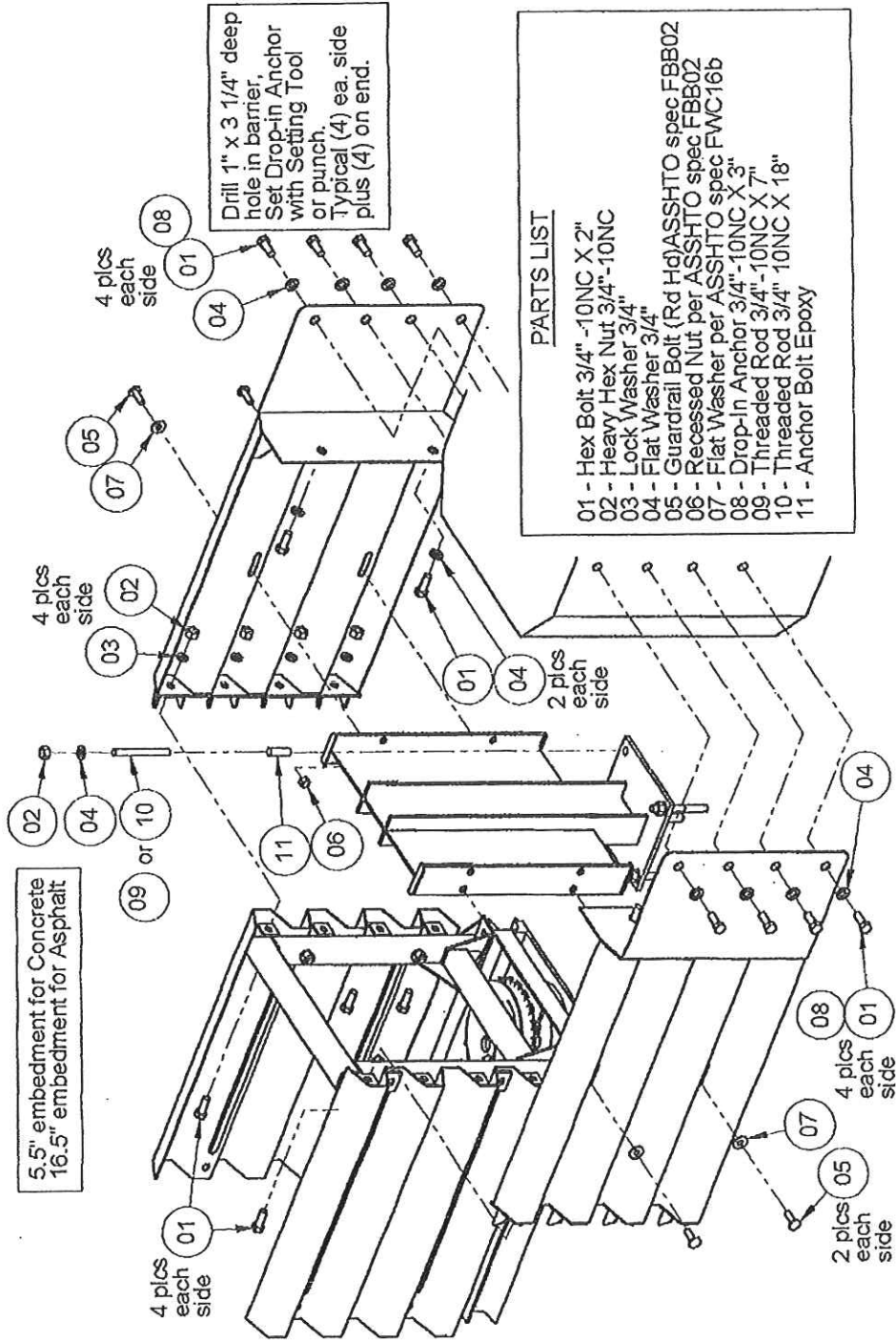

- PARTS LIST**
- 01 - Hex Bolt 3/4" -10NC X 2"
  - 02 - Heavy Hex Nut 3/4"-10NC
  - 03 - Lock Washer 3/4"
  - 04 - Flat Washer 3/4"
  - 05 - Guardrail Bolt (Rd Hd) ASSHTO spec FBB02
  - 06 - Recessed Nut per ASSHTO spec FBB02
  - 07 - Flat Washer per ASSHTO spec FWC166
  - 08 - Drop-In Anchor 3/4"-10NC X 3"
  - 09 - Threaded Rod 3/4"-10NC X 7"
  - 10 - Threaded Rod 3/4"-10NC X 18"
  - 11 - Anchor Bolt Epoxy

Drill 1" x 3 1/4" deep hole in barrier, Set Drop-in Anchor with Setting Tool or punch. Typical (4) ea. side plus (4) on end.

5.5" embedment for Concrete  
16.5" embedment for Asphalt

SMART CUSHION<sup>®</sup> by SCI Products Inc.

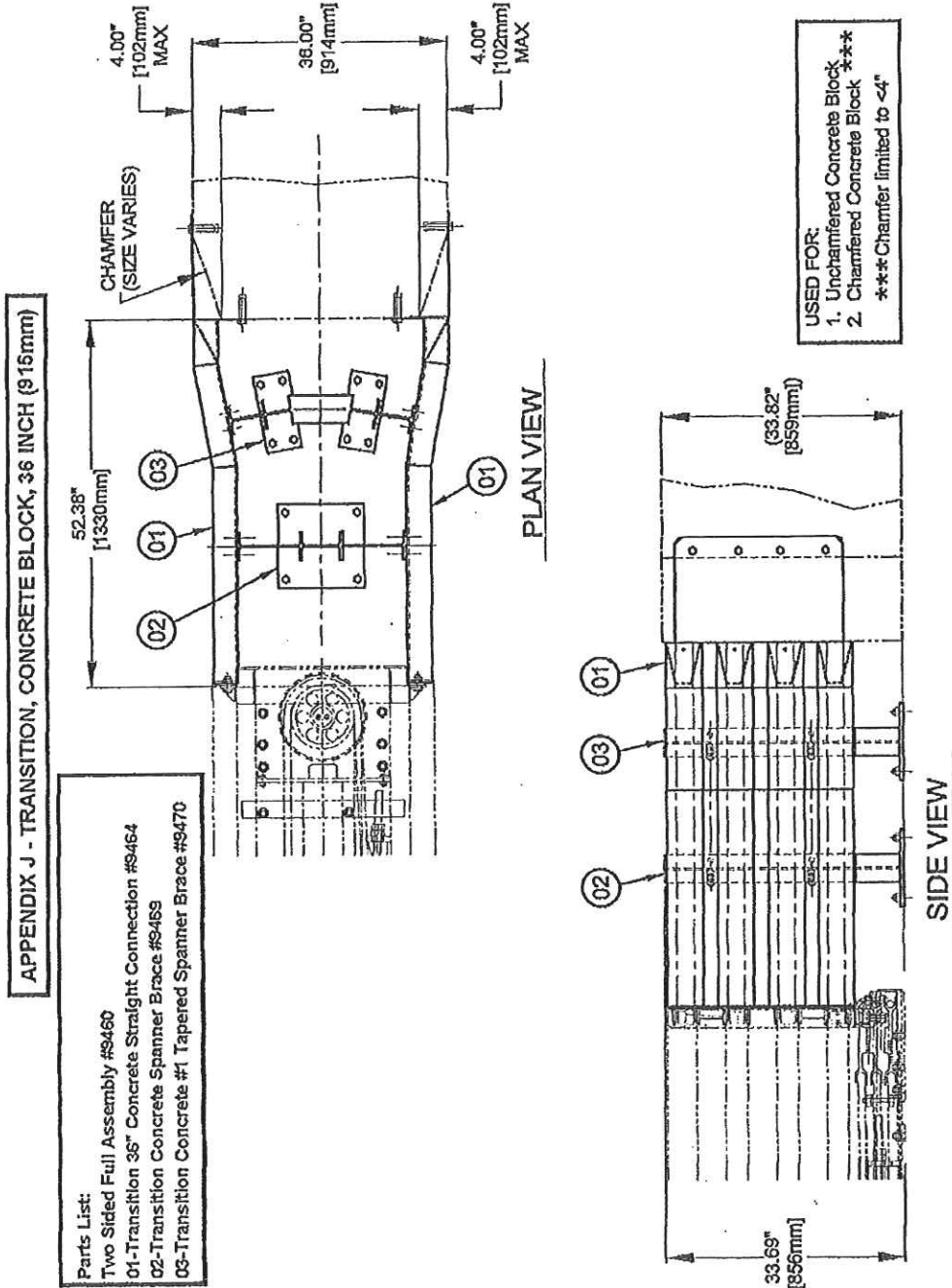



**APPENDIX M - TRANSITION, THRIE BEAM**

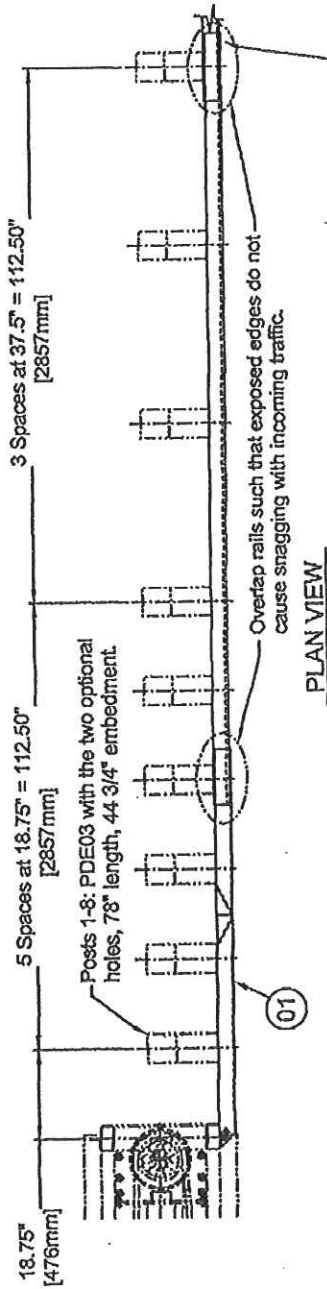

PLAN VIEW

\*\*\* GUARDRAILS, POSTS, BLOCKOUTS AND CONNECTION BOLTS BY OTHERS. \*\*\*

- Parts List  
 01 - Transition Thrie & W Beam - Right #9437  
 01 - Transition Thrie & W Beam - Left # 9438

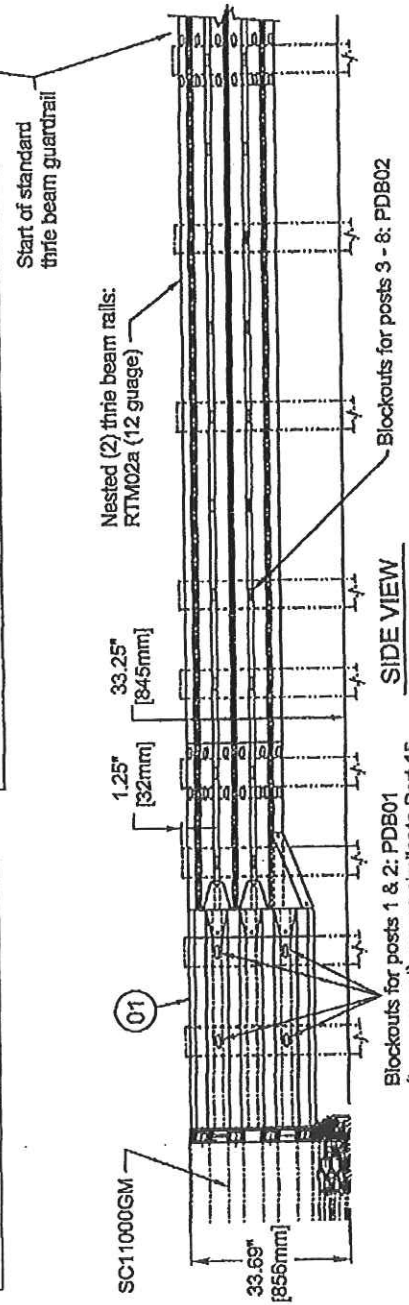

APPENDIX M(2) - TRANSITION, THRIE BEAM

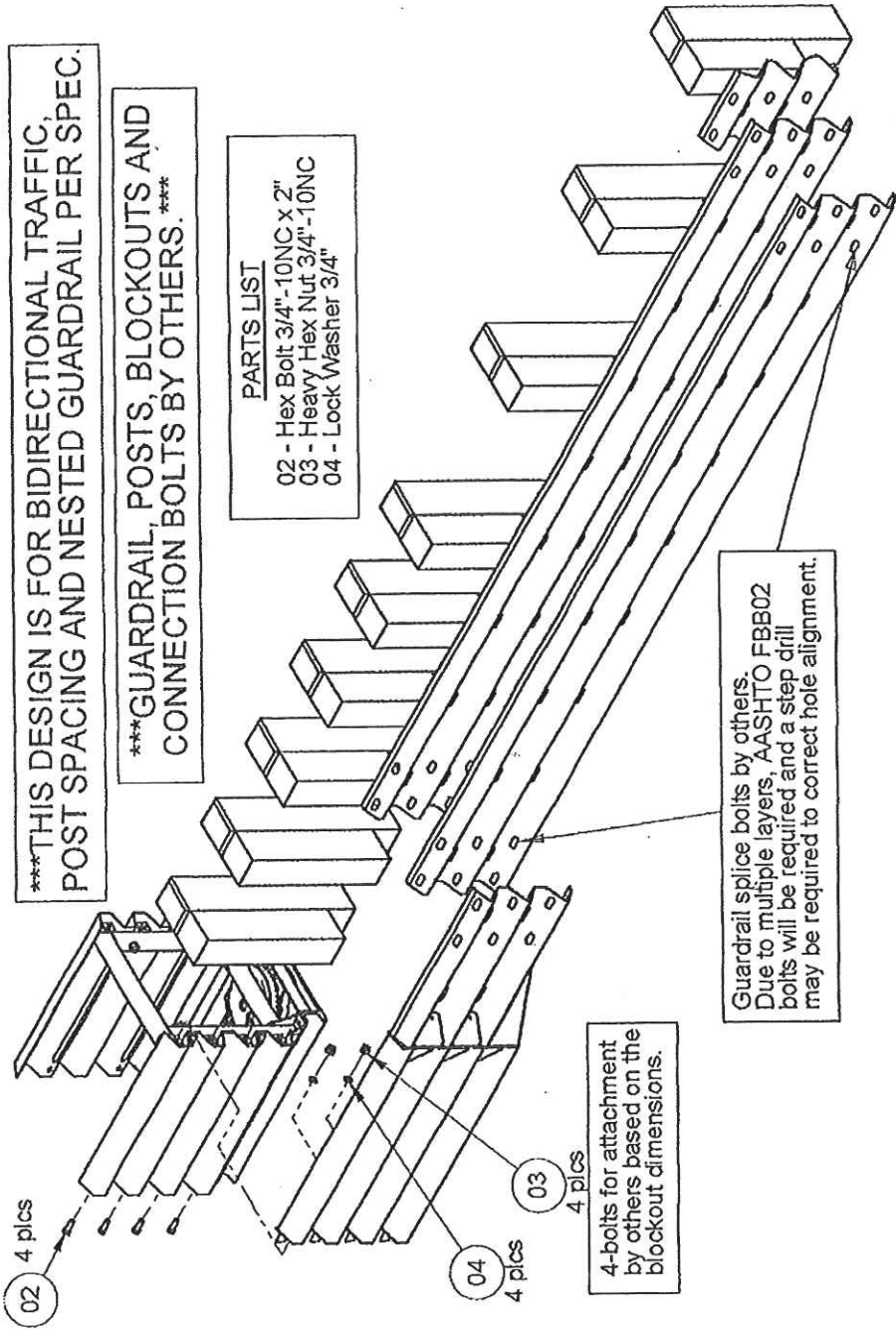

\*\*\*THIS DESIGN IS FOR BIDIRECTIONAL TRAFFIC, POST SPACING AND NESTED GUARDRAIL PER SPEC.

\*\*\*GUARDRAIL, POSTS, BLOCKOUTS AND CONNECTION BOLTS BY OTHERS. \*\*\*

- PARTS LIST
- 02 - Hex Bolt 3/4"-10NC x 2"
  - 03 - Heavy Hex Nut 3/4"-10NC
  - 04 - Lock Washer 3/4"

4-bolts for attachment by others based on the blockout dimensions.

Guardrail splice bolts by others. Due to multiple layers, AASHTO FBB02 bolts will be required and a step drill may be required to correct hole alignment.

**APPENDIX N - TRANSITION, W BEAM**  
**\*\*\*FOR USE WITH REVERSE DIRECTION TRAFFIC\*\*\***

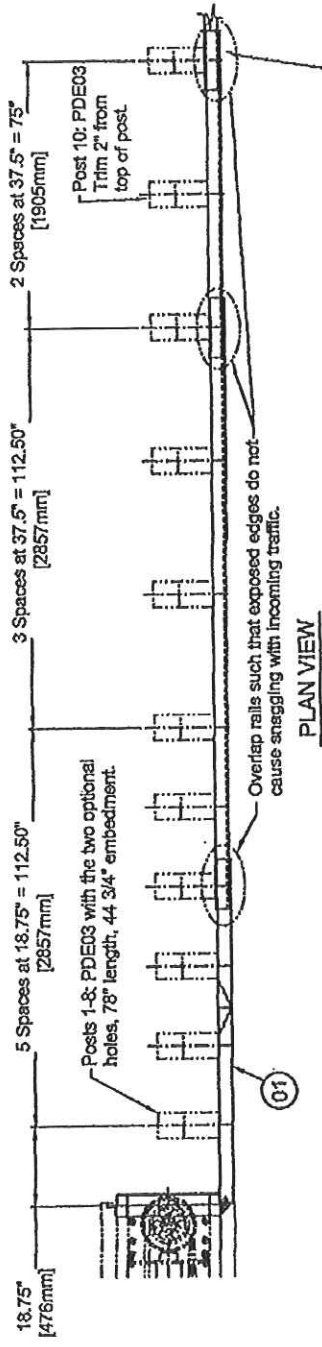

**PLAN VIEW**

**\*\*\*GUARDRAIL, POSTS, BLOCKOUTS AND CONNECTION BOLTS BY OTHERS.\*\*\***

- Parts List:  
 01 - Transition Thrie & W Beam - Right #9437  
 01 - Transition Thrie & W Beam - Left #9438

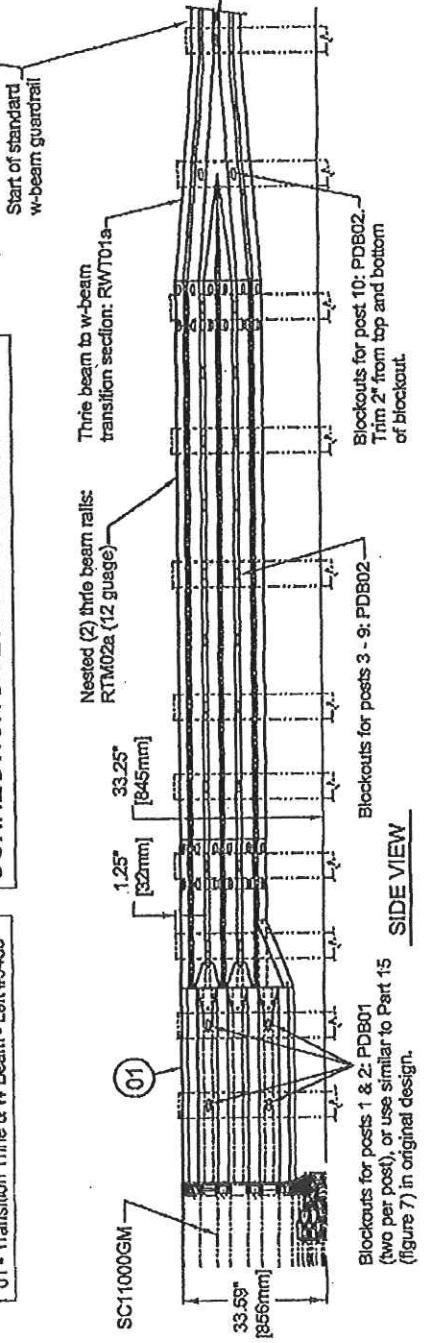



APPENDIX N(2) - TRANSITION, W BEAM

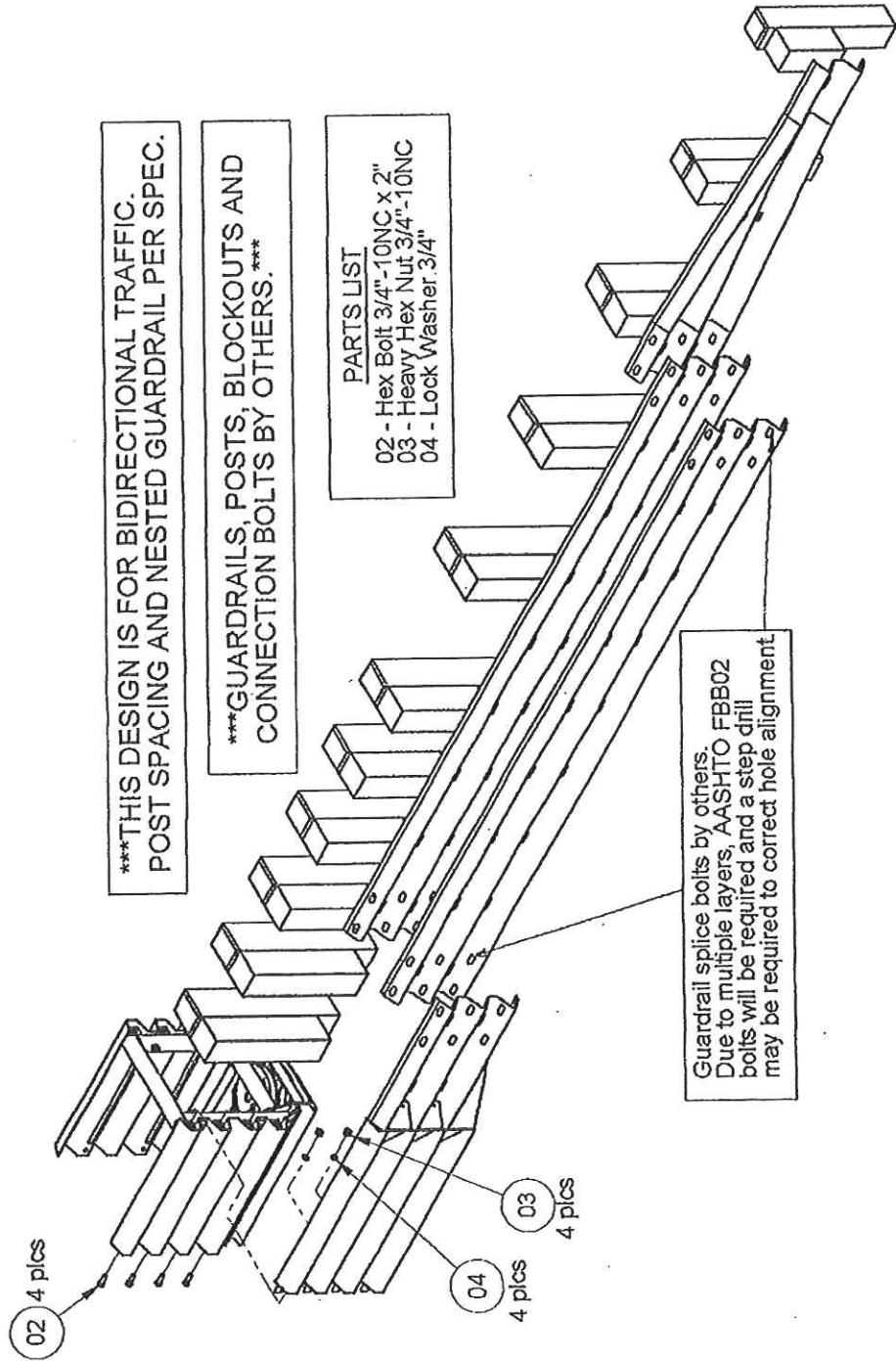

\*\*\*THIS DESIGN IS FOR BIDIRECTIONAL TRAFFIC. POST SPACING AND NESTED GUARDRAIL PER SPEC.

\*\*\*GUARDRAILS, POSTS, BLOCKOUTS AND CONNECTION BOLTS BY OTHERS.\*\*\*

- PARTS LIST
- 02 - Hex Bolt 3/4"-10NC x 2"
  - 03 - Heavy Hex Nut 3/4"-10NC
  - 04 - Lock Washer 3/4"

Guardrail splice bolts by others. Due to multiple layers, AASHTO FBB02 bolts will be required and a step drill may be required to correct hole alignment.

SMART CUSHION® by SCI Products Inc.

APPENDIX Q - TRANSITION, MEDIAN BARRIER - SINGLE SLOPE

- Parts List  
01 - Transition Single Slope Median Barrier - Right #9490  
01 - Transition Single Slope Median Barrier - Left #9491

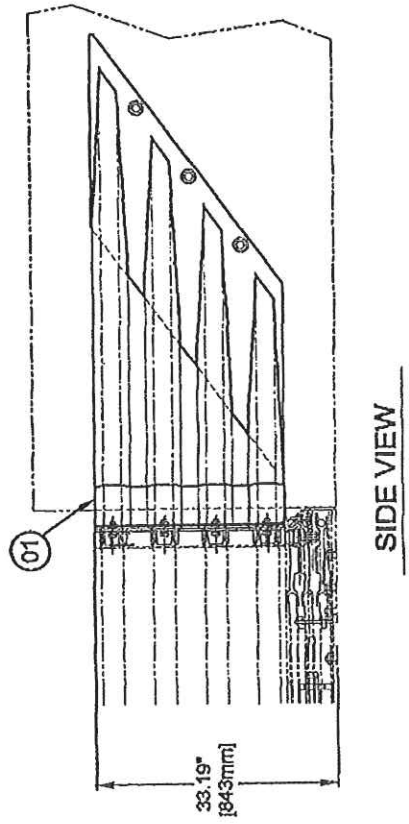
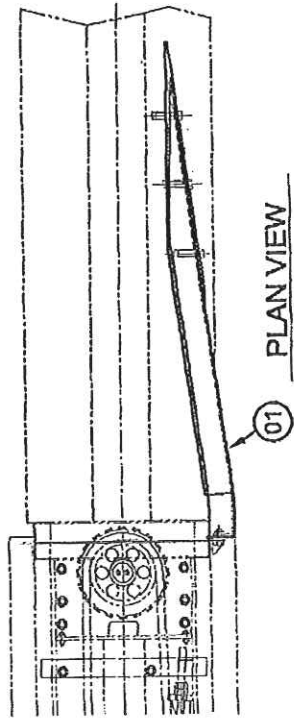

APPENDIX Q(2) - TRANSITION, MEDIAN BARRIER - SINGLE SLOPE

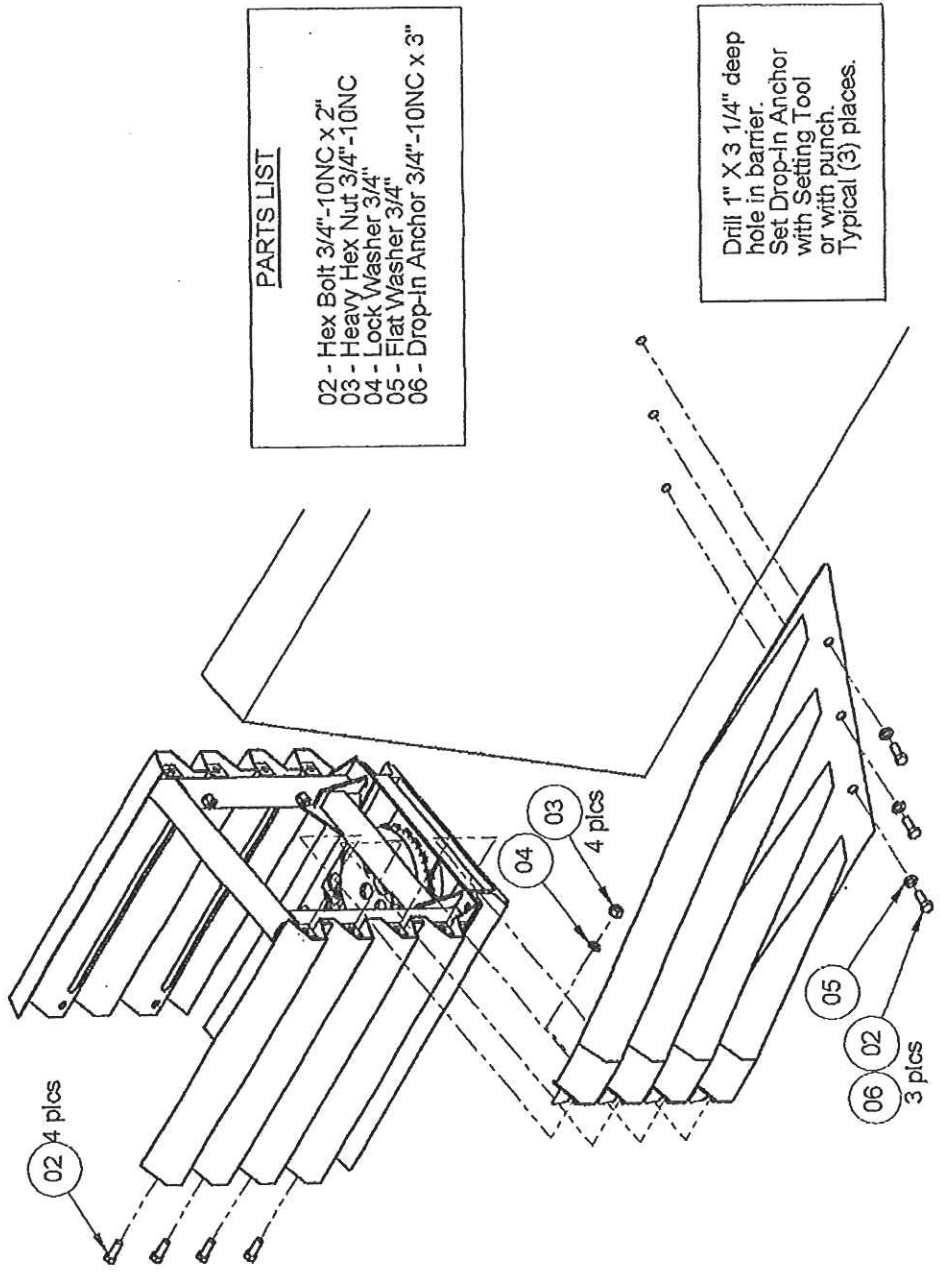

- PARTS LIST
- 02 - Hex Bolt 3/4"-10NC x 2"
  - 03 - Heavy Hex Nut 3/4"-10NC
  - 04 - Lock Washer 3/4"
  - 05 - Flat Washer 3/4"
  - 06 - Drop-In Anchor 3/4"-10NC x 3"

# VENDOR PREFERENCE CERTIFICATE

Certification and application\* is hereby made for Preference in accordance with *West Virginia Code*, §5A-3-37. (Does not apply to construction contracts). *West Virginia Code*, §5A-3-37, provides an opportunity for qualifying vendors to request (at the time of bid) preference for their residency status. Such preference is an evaluation method only and will be applied only to the cost bid in accordance with the *West Virginia Code*. This certificate for application is to be used to request such preference. The Purchasing Division will make the determination of the Resident Vendor Preference, if applicable.

**1. Application is made for 2.5% resident vendor preference for the reason checked:**

- \_\_\_\_\_ Bidder is an individual resident vendor and has resided continuously in West Virginia for four (4) years immediately preceding the date of this certification; **or**,
- \_\_\_\_\_ Bidder is a partnership, association or corporation resident vendor and has maintained its headquarters or principal place of business continuously in West Virginia for four (4) years immediately preceding the date of this certification; **or** 80% of the ownership interest of Bidder is held by another individual, partnership, association or corporation resident vendor who has maintained its headquarters or principal place of business continuously in West Virginia for four (4) years immediately preceding the date of this certification; **or**,
- \_\_\_\_\_ Bidder is a nonresident vendor which has an affiliate or subsidiary which employs a minimum of one hundred state residents and which has maintained its headquarters or principal place of business within West Virginia continuously for the four (4) years immediately preceding the date of this certification; **or**,

**2. Application is made for 2.5% resident vendor preference for the reason checked:**

- \_\_\_\_\_ Bidder is a resident vendor who certifies that, during the life of the contract, on average at least 75% of the employees working on the project being bid are residents of West Virginia who have resided in the state continuously for the two years immediately preceding submission of this bid; **or**,

**3. Application is made for 2.5% resident vendor preference for the reason checked:**

- \_\_\_\_\_ Bidder is a nonresident vendor employing a minimum of one hundred state residents or is a nonresident vendor with an affiliate or subsidiary which maintains its headquarters or principal place of business within West Virginia employing a minimum of one hundred state residents who certifies that, during the life of the contract, on average at least 75% of the employees or Bidder's affiliate's or subsidiary's employees are residents of West Virginia who have resided in the state continuously for the two years immediately preceding submission of this bid; **or**,

**4. Application is made for 5% resident vendor preference for the reason checked:**

- \_\_\_\_\_ Bidder meets either the requirement of both subdivisions (1) and (2) or subdivision (1) and (3) as stated above; **or**,

**5. Application is made for 3.5% resident vendor preference who is a veteran for the reason checked:**

- \_\_\_\_\_ Bidder is an individual resident vendor who is a veteran of the United States armed forces, the reserves or the National Guard and has resided in West Virginia continuously for the four years immediately preceding the date on which the bid is submitted; **or**,

**6. Application is made for 3.5% resident vendor preference who is a veteran for the reason checked:**

- \_\_\_\_\_ Bidder is a resident vendor who is a veteran of the United States armed forces, the reserves or the National Guard, if, for purposes of producing or distributing the commodities or completing the project which is the subject of the vendor's bid and continuously over the entire term of the project, on average at least seventy-five percent of the vendor's employees are residents of West Virginia who have resided in the state continuously for the two immediately preceding years.

Bidder understands if the Secretary of Revenue determines that a Bidder receiving preference has failed to continue to meet the requirements for such preference, the Secretary may order the Director of Purchasing to: (a) reject the bid; or (b) assess a penalty against such Bidder in an amount not to exceed 5% of the bid amount and that such penalty will be paid to the contracting agency or deducted from any unpaid balance on the contract or purchase order.

By submission of this certificate, Bidder agrees to disclose any reasonably requested information to the Purchasing Division and authorizes the Department of Revenue to disclose to the Director of Purchasing appropriate information verifying that Bidder has paid the required business taxes, provided that such information does not contain the amounts of taxes paid nor any other information deemed by the Tax Commissioner to be confidential.

**Under penalty of law for false swearing (West Virginia Code, §61-5-3), Bidder hereby certifies that this certificate is true and accurate in all respects; and that if a contract is issued to Bidder and if anything contained within this certificate changes during the term of the contract, Bidder will notify the Purchasing Division in writing immediately.**

Bidder: \_\_\_\_\_ Signed: \_\_\_\_\_

Date: \_\_\_\_\_ Title: \_\_\_\_\_

\*Check any combination of preference consideration(s) indicated above, which you are entitled to receive.

RFQ No. 8512C2018

STATE OF WEST VIRGINIA  
Purchasing Division

**PURCHASING AFFIDAVIT**

West Virginia Code §5A-3-10a states: No contract or renewal of any contract may be awarded by the state or any of its political subdivisions to any vendor or prospective vendor when the vendor or prospective vendor or a related party to the vendor or prospective vendor is a debtor and the debt owned is an amount greater than one thousand dollars in the aggregate

**DEFINITIONS:**

"Debt" means any assessment, premium, penalty, fine, tax or other amount of money owed to the state or any of its political subdivisions because of a judgment, fine, permit violation, license assessment, defaulted workers' compensation premium, penalty or other assessment presently delinquent or due and required to be paid to the state or any of its political subdivisions, including any interest or additional penalties accrued thereon.

"Debtor" means any individual, corporation, partnership, association, Limited Liability Company or any other form or business association owing a debt to the state or any of its political subdivisions. "Political subdivision" means any county commission; municipality; county board of education; any instrumentality established by a county or municipality; any separate corporation or instrumentality established by one or more counties or municipalities, as permitted by law; or any public body charged by law with the performance of a government function or whose jurisdiction is coextensive with one or more counties or municipalities. "Related party" means a party, whether an individual, corporation, partnership, association, limited liability company or any other form or business association or other entity whatsoever, related to any vendor by blood, marriage, ownership or contract through which the party has a relationship of ownership or other interest with the vendor so that the party will actually or by effect receive or control a portion of the benefit, profit or other consideration from performance of a vendor contract with the party receiving an amount that meets or exceeds five percent of the total contract amount.

**EXCEPTION:** The prohibition of this section does not apply where a vendor has contested any tax administered pursuant to chapter eleven of this code, workers' compensation premium, permit fee or environmental fee or assessment and the matter has not become final or where the vendor has entered into a payment plan or agreement and the vendor is not in default of any of the provisions of such plan or agreement.

Under penalty of law for false swearing (*West Virginia Code §61-5-3*), it is hereby certified that the vendor affirms and acknowledges the information in this affidavit and is in compliance with the requirements as stated.

**WITNESS THE FOLLOWING SIGNATURE**

Vendor's Name: Protection Services Inc

Authorized Signature: [Signature] Vice President Date: 8/29/11

State of Pennsylvania

County of DAUPHIN, to-wit:

Taken, subscribed, and sworn to before me this 29 day of AUGUST 2011

My Commission expires MAY 24, 2014

AFFIX SEAL HERE

NOTARY PUBLIC

[Signature]

