



State of West Virginia
 Department of Administration
 Purchasing Division
 2019 Washington Street East
 Post Office Box 50130
 Charleston, WV 25305-0130

Request for Quotation

RFQ NUMBER
7012C004

PAGE
1

ADDRESS CORRESPONDENCE TO ATTENTION OF:
PAUL REYNOLDS 304-558-0468

VENDOR

*709042444 304-776-4091
 ELECTRONIC COMMUNICATIONS WV
 408 OLD GOFF MOUNTAIN ROAD
 CROSS LANES WV 25313

SHIP TO

DIVISION OF HIGHWAYS
 EQUIPMENT DIVISION
 VARIOUS LOCALES AS INDICATED
 BY ORDER

DATE PRINTED	TERMS OF SALE	SHIP VIA	F.O.B.	FREIGHT TERMS
09/02/2011	NET 30 Days	Best way	Dest	PAID Shipper
BID OPENING DATE: 09/28/2011		BID OPENING TIME 01:30PM		

LINE	QUANTITY	UOP	CAT. NO.	ITEM NUMBER	UNIT PRICE	AMOUNT
0001		EA		120-50		
LIGHTS, BEACON AND SIGNAL (MARINE)						
REQUEST FOR QUOTATION OPEN END CONTRACT						
THE WEST VIRGINIA STATE PURCHASING DIVISION FOR THE AGENCY THE WEST VIRGINIA DIVISION OF HIGHWAYS IS SOLICITING BIDS FOR AN OPEN END CONTRACT TO PROVIDE LED BEACONS PER THE ATTACHED SPECIFICATIONS.						
TECHNICAL QUESTIONS CONCERNING THIS SOLICITATION MUST BE SUBMITTED IN WRITING TO PAUL REYNOLDS IN THE WEST VIRGINIA STATE PURCHASING DIVISION VIA MAIL AT THE ADDRESS SHOWN IN THE BODY OF THIS RFQ, VIA FAX AT 304-558-2596, OR VIA EMAIL AT PAUL.REYNOLDS@WV.GOV. DEADLINE FOR ALL TECHNICAL QUESTIONS IS 09/23/2011, AT THE CLOSE OF BUSINESS. ANY TECHNICAL QUESTIONS RECEIVED WILL BE ANSWERED BY FORMAL ADDENDUM TO BE ISSUED BY THE PURCHASING DIVISION AFTER THE DEADLINE HAS LAPSED.						
EXHIBIT 3						
LIFE OF CONTRACT: THIS CONTRACT BECOMES EFFECTIVE UPON AWARD AND EXTENDS FOR A PERIOD OF ONE (1) YEAR OR UNTIL SUCH "REASONABLE TIME" THEREAFTER AS IS NECESSARY TO OBTAIN A NEW CONTRACT OR RENEW THE ORIGINAL CONTRACT. THE "REASONABLE TIME" PERIOD SHALL NOT EXCEED TWELVE (12) MONTHS. DURING THIS "REASONABLE						

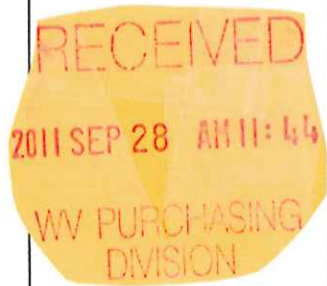

SIGNATURE <i>[Signature]</i>				SEE REVERSE SIDE FOR TERMS AND CONDITIONS		TELEPHONE 304-776-4091		DATE Sept-27-2011	
TITLE President		FEN 550520604		ADDRESS CHANGES TO BE NOTED ABOVE					

WHEN RESPONDING TO RFQ, INSERT NAME AND ADDRESS IN SPACE ABOVE LABELED 'VENDOR'

GENERAL TERMS & CONDITIONS REQUEST FOR QUOTATION (RFQ) AND REQUEST FOR PROPOSAL (RFP)

1. Awards will be made in the best interest of the State of West Virginia.
2. The State may accept or reject in part, or in whole, any bid.
3. Prior to any award, the apparent successful vendor must be properly registered with the Purchasing Division and have paid the required \$125 fee.
4. All services performed or goods delivered under State Purchase Order/Contracts are to be continued for the term of the Purchase Order/Contracts, contingent upon funds being appropriated by the Legislature or otherwise being made available. In the event funds are not appropriated or otherwise available for these services or goods this Purchase Order/Contract becomes void and of no effect after June 30.
5. Payment may only be made after the delivery and acceptance of goods or services.
6. Interest may be paid for late payment in accordance with the *West Virginia Code*.
7. Vendor preference will be granted upon written request in accordance with the *West Virginia Code*.
8. The State of West Virginia is exempt from federal and state taxes and will not pay or reimburse such taxes.
9. The Director of Purchasing may cancel any Purchase Order/Contract upon 30 days written notice to the seller.
10. The laws of the State of West Virginia and the *Legislative Rules* of the Purchasing Division shall govern the purchasing process.
11. Any reference to automatic renewal is hereby deleted. The Contract may be renewed only upon mutual written agreement of the parties.
12. **BANKRUPTCY:** In the event the vendor/contractor files for bankruptcy protection, the State may deem this contract null and void, and terminate such contract without further order.
13. **HIPAA BUSINESS ASSOCIATE ADDENDUM:** The West Virginia State Government HIPAA Business Associate Addendum (BAA), approved by the Attorney General, is available online at www.state.wv.us/admin/purchase/vrc/hipaa.htm and is hereby made part of the agreement. Provided that the Agency meets the definition of a Cover Entity (45 CFR §160.103) and will be disclosing Protected Health Information (45 CFR §160.103) to the vendor.
14. **CONFIDENTIALITY:** The vendor agrees that he or she will not disclose to anyone, directly or indirectly, any such personally identifiable information or other confidential information gained from the agency, unless the individual who is the subject of the information consents to the disclosure in writing or the disclosure is made pursuant to the agency's policies, procedures, and rules. Vendor further agrees to comply with the Confidentiality Policies and Information Security Accountability Requirements, set forth in <http://www.state.wv.us/admin/purchase/privacy/noticeConfidentiality.pdf>.
15. **LICENSING:** Vendors must be licensed and in good standing in accordance with any and all state and local laws and requirements by any state or local agency of West Virginia, including, but not limited to, the West Virginia Secretary of State's Office, the West Virginia Tax Department, and the West Virginia Insurance Commission. The vendor must provide all necessary releases to obtain information to enable the director or spending unit to verify that the vendor is licensed and in good standing with the above entities.
16. **ANTITRUST:** In submitting a bid to any agency for the State of West Virginia, the bidder offers and agrees that if the bid is accepted the bidder will convey, sell, assign or transfer to the State of West Virginia all rights, title and interest in and to all causes of action it may now or hereafter acquire under the antitrust laws of the United States and the State of West Virginia for price fixing and/or unreasonable restraints of trade relating to the particular commodities or services purchased or acquired by the State of West Virginia. Such assignment shall be made and become effective at the time the purchasing agency tenders the initial payment to the bidder.

I certify that this bid is made without prior understanding, agreement, or connection with any corporation, firm, limited liability company, partnership, or person or entity submitting a bid for the same material, supplies, equipment or services and is in all respects fair and without collusion or fraud. I further certify that I am authorized to sign the certification on behalf of the bidder or this bid.

INSTRUCTIONS TO BIDDERS

1. Use the quotation forms provided by the Purchasing Division. Complete all sections of the quotation form.
2. Items offered must be in compliance with the specifications. Any deviation from the specifications must be clearly indicated by the bidder. Alternates offered by the bidder as **EQUAL** to the specifications must be clearly defined. A bidder offering an alternate should attach complete specifications and literature to the bid. The Purchasing Division may waive minor deviations to specifications.
3. Unit prices shall prevail in case of discrepancy. All quotations are considered F.O.B. destination unless alternate shipping terms are clearly identified in the quotation.
4. All quotations must be delivered by the bidder to the office listed below prior to the date and time of the bid opening. Failure of the bidder to deliver the quotations on time will result in bid disqualifications: Department of Administration, Purchasing Division, 2019 Washington Street East, P.O. Box 50130, Charleston, WV 25305-0130
5. Communication during the solicitation, bid, evaluation or award periods, except through the Purchasing Division, is strictly prohibited (W.Va. C.S.R. §148-1-6.6).



State of West Virginia
 Department of Administration
 Purchasing Division
 2019 Washington Street East
 Post Office Box 50130
 Charleston, WV 25305-0130

Request for Quotation

RFQ NUMBER
7012C004

PAGE
2

ADDRESS CORRESPONDENCE TO ATTENTION OF:
PAUL REYNOLDS 304-558-0468

*709042444 304-776-4091
 ELECTRONIC COMMUNICATIONS WV
 408 OLD GOFF MOUNTAIN ROAD
 CROSS LANES WV 25313

POST OFFICE

SHIP TO

DIVISION OF HIGHWAYS
 EQUIPMENT DIVISION
 VARIOUS LOCALES AS INDICATED
 BY ORDER

DATE PRINTED	TERMS OF SALE	SHIP VIA	F.O.B.	FREIGHT TERMS
09/02/2011				

BID OPENING DATE: 09/28/2011 BID OPENING TIME 01:30PM

LINE	QUANTITY	UOP	CAT. NO.	ITEM NUMBER	UNIT PRICE	AMOUNT
<p>TIME" THE VENDOR MAY TERMINATE THIS CONTRACT FOR ANY REASON UPON GIVING THE DIRECTOR OF PURCHASING 30 DAYS WRITTEN NOTICE.</p> <p>UNLESS SPECIFIC PROVISIONS ARE STIPULATED ELSEWHERE IN THIS CONTRACT DOCUMENT, THE TERMS, CONDITIONS AND PRICING SET HEREIN ARE FIRM FOR THE LIFE OF THE CONTRACT.</p> <p>RENEWAL: THIS CONTRACT MAY BE RENEWED UPON THE MUTUAL WRITTEN CONSENT OF THE SPENDING UNIT AND VENDOR, SUBMITTED TO THE DIRECTOR OF PURCHASING THIRTY (30) DAYS PRIOR TO THE EXPIRATION DATE. SUCH RENEWAL SHALL BE IN ACCORDANCE WITH THE TERMS AND CONDITIONS OF THE ORIGINAL CONTRACT AND SHALL BE LIMITED TO TWO (2) ONE (1) YEAR PERIODS.</p> <p>CANCELLATION: THE DIRECTOR OF PURCHASING RESERVES THE RIGHT TO CANCEL THIS CONTRACT IMMEDIATELY UPON WRITTEN NOTICE TO THE VENDOR IF THE COMMODITIES AND/OR SERVICES SUPPLIED ARE OF AN INFERIOR QUALITY OR DO NOT CONFORM TO THE SPECIFICATIONS OF THE BID AND CONTRACT HEREIN.</p> <p>OPEN MARKET CLAUSE: THE DIRECTOR OF PURCHASING MAY AUTHORIZE A SPENDING UNIT TO PURCHASE ON THE OPEN MARKET, WITHOUT THE FILING OF A REQUISITION OR COST ESTIMATE, ITEMS SPECIFIED ON THIS CONTRACT FOR IMMEDIATE DELIVERY IN EMERGENCIES DUE TO UNFORESEEN CAUSES (INCLUDING BUT NOT LIMITED TO DELAYS IN TRANSPORTATION OR AN UNANTICIPATED INCREASE IN THE VOLUME OF WORK.)</p> <p>QUANTITIES: QUANTITIES LISTED IN THE REQUISITION ARE APPROXIMATIONS ONLY, BASED ON ESTIMATES SUPPLIED BY THE STATE SPENDING UNIT. IT IS UNDERSTOOD AND AGREED THAT THE CONTRACT SHALL COVER THE QUANTITIES ACTUALLY</p>						

SEE REVERSE SIDE FOR TERMS AND CONDITIONS

SIGNATURE	TELEPHONE	DATE
TITLE	FEIN	ADDRESS CHANGES TO BE NOTED ABOVE

WHEN RESPONDING TO RFQ, INSERT NAME AND ADDRESS IN SPACE ABOVE LABELED 'VENDOR'



State of West Virginia
 Department of Administration
 Purchasing Division
 2019 Washington Street East
 Post Office Box 50130
 Charleston, WV 25305-0130

Request for Quotation

RFQ NUMBER
7012C004

PAGE
3

ADDRESS CORRESPONDENCE TO ATTENTION OF:
PAUL REYNOLDS 304-558-0468

VENDOR

*709042444 304-776-4091
 ELECTRONIC COMMUNICATIONS WV
 408 OLD GOFF MOUNTAIN ROAD
 CROSS LANES WV 25313

SHIP TO

DIVISION OF HIGHWAYS
 EQUIPMENT DIVISION
 VARIOUS LOCALES AS INDICATED
 BY ORDER

DATE PRINTED	TERMS OF SALE	SHIP VIA	F.O.B.	FREIGHT TERMS
09/02/2011				

BID OPENING DATE: 09/28/2011 BID OPENING TIME 01:30PM

LINE	QUANTITY	UOP	CAT NO	ITEM NUMBER	UNIT PRICE	AMOUNT
<p>ORDERED FOR DELIVERY DURING THE TERM OF THE CONTRACT, WHETHER MORE OR LESS THAN THE QUANTITIES SHOWN.</p> <p>ORDERING PROCEDURE: SPENDING UNIT(S) SHALL ISSUE A WRITTEN STATE CONTRACT ORDER (FORM NUMBER WV-39) TO THE VENDOR FOR COMMODITIES COVERED BY THIS CONTRACT. THE ORIGINAL COPY OF THE WV-39 SHALL BE MAILED TO THE VENDOR AS AUTHORIZATION FOR SHIPMENT, A SECOND COPY MAILED TO THE PURCHASING DIVISION, AND A THIRD COPY RETAINED BY THE SPENDING UNIT.</p> <p>BANKRUPTCY: IN THE EVENT THE VENDOR/CONTRACTOR FILES FOR BANKRUPTCY PROTECTION, THE STATE MAY DEEM THE CONTRACT NULL AND VOID, AND TERMINATE SUCH CONTRACT WITHOUT FURTHER ORDER.</p> <p>THE TERMS AND CONDITIONS CONTAINED IN THIS CONTRACT SHALL SUPERSEDE ANY AND ALL SUBSEQUENT TERMS AND CONDITIONS WHICH MAY APPEAR ON ANY ATTACHED PRINTED DOCUMENTS SUCH AS PRICE LISTS, ORDER FORMS, SALES AGREEMENTS OR MAINTENANCE AGREEMENTS, INCLUDING ANY ELECTRONIC MEDIUM SUCH AS CD-ROM.</p> <p>REV. 05/26/2009</p> <p>EXHIBIT 4</p> <p>LOCAL GOVERNMENT BODIES: UNLESS THE VENDOR INDICATES IN THE BID HIS REFUSAL TO EXTEND THE PRICES, TERMS, AND CONDITIONS OF THE BID TO COUNTY, SCHOOL, MUNICIPAL AND OTHER LOCAL GOVERNMENT BODIES, THE BID SHALL EXTEND TO POLITICAL SUBDIVISIONS OF THE STATE OF WEST VIRGINIA. IF THE VENDOR DOES NOT WISH TO EXTEND THE PRICES, TERMS, AND CONDITIONS OF THE BID TO ALL POLITICAL SUBDIVISIONS OF THE STATE, THE VENDOR MUST CLEARLY INDICATE SUCH REFUSAL IN HIS BID. SUCH REFUSA</p>						

SEE REVERSE SIDE FOR TERMS AND CONDITIONS		
SIGNATURE	TELEPHONE	DATE
TITLE	FEIN	ADDRESS CHANGES TO BE NOTED ABOVE

WHEN RESPONDING TO RFQ, INSERT NAME AND ADDRESS IN SPACE ABOVE LABELED 'VENDOR'



State of West Virginia
 Department of Administration
 Purchasing Division
 2019 Washington Street East
 Post Office Box 50130
 Charleston, WV 25305-0130

Request for Quotation

RFQ NUMBER
7012C004

PAGE
5

ADDRESS CORRESPONDENCE TO ATTENTION OF:
PAUL REYNOLDS 304-558-0468

V E N D O R
*709042444 304-776-4091 ELECTRONIC COMMUNICATIONS WV 408 OLD GOFF MOUNTAIN ROAD CROSS LANES WV 25313

S H I P T O
DIVISION OF HIGHWAYS EQUIPMENT DIVISION VARIOUS LOCALES AS INDICATED BY ORDER

DATE PRINTED	TERMS OF SALE	SHIP VIA	F.O.B.	FREIGHT TERMS
09/02/2011				

BID OPENING DATE: 09/28/2011 BID OPENING TIME 01:30PM

LINE	QUANTITY	UOP	CAT NO	ITEM NUMBER	UNIT PRICE	AMOUNT
BID OPENING DATE:				09/28/2011		
BID OPENING TIME:				01:30 P.M.		
PLEASE PROVIDE A FAX NUMBER IN CASE IT IS NECESSARY TO CONTACT YOU REGARDING YOUR BID:						
----- 304 776-7092 -----						
CONTACT PERSON (PLEASE PRINT CLEARLY):						
----- Tim Ford -----						
***** THIS IS THE END OF RFQ 7012C004 ***** TOTAL: _____						

SEE REVERSE SIDE FOR TERMS AND CONDITIONS		
SIGNATURE	TELEPHONE	DATE
TITLE	FEIN	ADDRESS CHANGES TO BE NOTED ABOVE

WHEN RESPONDING TO RFQ, INSERT NAME AND ADDRESS IN SPACE ABOVE LABELED 'VENDOR'

**LED BEACON
OR EQUAL CONTRACT
7012C004**

I. PURPOSE AND SCOPE:

The purpose of this Request for Quotation No. 7012C004 and resulting contract ("Contract") between West Virginia Department of Transportation, Division of Highways ("DOH") and the winning vendor ("Vendor") is to provide LED BEACONS as required by the WV DOH.

II. GENERAL REQUIREMENTS:

1. Exhibit A provides a list of part numbers that must be provided. Exhibit A must be completed for evaluation purposes. Exhibit A is Only a partial list of parts that may be required by DOH.
2. Upon request vendor will provide proof of all mandatory requirements.

III. PRICING:

1. This Contract shall be awarded based on a single price. Exhibit A.
2. **This Contract shall be limited to the two items listed.**
3. Vendor shall submit the Bid Evaluation Price Chart, attached hereto and incorporated herein by reference as Exhibit A, to allow bid evaluation. The Vendor should insert the manufacturer's discounted unit price in the space provided. The Vendor should then multiply the estimated quantity by the discounted unit price to obtain the total discounted price to agency.

IV. ORDERING INFORMATION:

1. Parts orders against this contract may be placed by the DOH Equipment Division and any other DOH District locations. A list of the current DOH locations is attached as Exhibit B. Orders may be placed by telephone and/or facsimile.

V. DELIVERY REQUIREMENTS:

1. Vendor must ship all items to DOH under this Contract FOB DESTINATION.
2. DOH will pay freight charges only if DOH request 24 hour delivery.
3. Vendor shall deliver the goods to the DOH locations as requested by DOH. A list of the DOH locations is attached hereto and incorporated herein by reference as Exhibit B. DOH reserves the right to change DOH locations or request delivery to another location

at no additional charge after notifying Vendor of the new location and requesting delivery thereto.

4. Delivery is an integral part of this contract and Vendor's failing to comply with the delivery terms will be grounds for submission of a WV-82 Form officially notifying the Purchasing Division and the Vendor of unsatisfactory performance.
5. Vendor's failure to obtain prior approval from DOH for changes to delivery schedules or to deliver the goods in a timely manner may be grounds for cancellation of this Contract.
6. Vendor must ship orders promptly upon receipt and delivery must be made within three (3) business days of receipt of an order. Vendor shall not require that a certain order quantity be met prior to shipping DOH orders.
7. If Vendor cannot deliver the goods ordered within three working days then Vendor shall immediately notify DOH of the anticipated delivery date. If DOH finds the delivery date unacceptable then DOH may purchase the needed items on the open market with approval from the DOH Equipment Division Director, the DOH District Equipment Supervisor, or a designee of either. Any open market purchase made hereunder shall be in accordance with the laws, rules, and regulations, of the Department of Administration, Purchasing Division.
8. DOH is not responsible for any restocking charge on items that are returned to Vendor as faulty or for failure to conform to the required specifications. In all other instances, DOH will only pay restocking fees if DOH, in its sole discretion, believes that such a charge is warranted.
9. All deliveries must be conspicuously marked with the DOH Purchase Order Number. Any goods delivered without this information may be returned to Vendor at Vendor's expense.

VI. PAYMENT:

1. The State of West Virginia currently utilizes a Visa purchasing card program. The State of West Virginia Visa purchasing card is the preferred method of payment, but other methods of payments may be utilized from time to time at the sole discretion of DOH. The successful vendor must accept the State of West Virginia Visa purchasing card for payment of all orders placed under this Contract.
2. Vendor must supply a credit receipt, sales receipt, or cash register receipt to DOH after Payment has been made.
3. Payment shall be made after DOH has received and accepted the goods being delivered. Vendor shall not charge the State of West Virginia Visa purchasing card until goods are received and accepted by DOH.

VII. MISCELLANEOUS:

1. All warranty claims that require field service shall be performed by Vendor at no cost to DOH.
2. Vendor shall furnish any technical engineering service which might be needed in the proper installation of these parts at no extra cost to the DOH.
3. Vendor shall comply with all federal, state, and local laws, rules and regulations.
4. Concurrently with each shipment, Vendor shall forward a proper and current Material Safety Data Sheet ("MSDS") to the DOH Equipment Division in Buckhannon, WV. Vendor shall also furnish the State of West Virginia and/or any of its other agencies with Additional MSDS as requested.
5. Vendor shall assume all liability and costs for failures and downtime that result from DOH use of Vendor's products.
6. This Contract will be awarded complete and not split.
7. Vendor must guarantee that it will maintain adequate stock to supply the needs of DOH at all times.

PLEASE SEE ATTACHED SPECIFICATIONS

**CONTRACT 7012C004
LED BEACON**

1.00 LED BEACON CLASS 1

1.1 Voltage 12V and 24V

1.2 AMPS 1.5 MAX @ 12.8V

2.0 Must have High Intensity White light source with 360 visibility (Yellow/Amber not acceptable)

2.1 Must have selectable flash patterns from external source

2.2 Must have high/low intensity circuit

2.3 Overall height not to exceed 6"

2.4 Must be RFI protected

2.5 Must have reverse polarity protection

3.0 Combination Mounting Base

3.1 Shall be made of polycarbonate not to exceed 6 ¾ "Diameter

3.2 Shall have 3 bolt mounting spaced at 120 degree and also have a female 1" NPT pipe fitting

4.0 Circuit Board and Electronics shall be conformal coated to provide moisture and corrosion protection.

5.0 Optic Dome must be Amber, made of polycarbonate meeting Standard 1079 or better.

6.0 Must meet SAE J845 May 1997, Class 1 in Amber

6.1 Must be AMECA Certified

6.2 Must provide proof of certifications with bid.

7.0 Warranty may be a factor in bid evaluation

7.1 Sample of bid unit may be required for RFI testing before award of Contract.

7.2 Vendor must provide literature which supports compliance to above specifications.

7.3 Quoted prices must include Freight Charges on quantities of 6 or more.

7.4 Freight may be charged on quantities of 5 or less.

EXHIBIT B: DIVISION OF HIGHWAYS LOCATIONS

Equipment Division

WV Division of Highways
 PO Box 610
 Buckhannon, WV 26201
 ATTENTION: Kevin Riley (FOUR COPIES)

WVDOT/Division of Highways
 D-1
 1340 Smith St.
 Charleston, WV 25301
 Attn: Bob Heckert

WVDOT/Division of Highways
 D-2
 Po. Box 880
 Huntington, WV 25712
 Attn: Barbara King

WVDOT/Division of Highways
 D-3
 626 Depot St.
 Parkersburg, WV 26101
 Attn: Beverly Myers

WVDOT/Division of Highways
 D-4
 P.O. BOX 2570
 Clarksburg, WV 26301
 Attn: John Bartlett

WVDOT/Division of Highways
 D-5
 PO BOX 99
 BURLINGTON, WV 26710
 Attn: Laranda Baldwin

WVDOT/Division of Highways
 D-6
 1 DOT Drive.
 Moundsville, WV 26041-2353
 Attn: Carol Ryan

WVDOT/Division Highways
 D-7
 Drawer 1228
 Weston, WV 26452
 Attn: Melissa Jordan

WVDOT/Division of Highways
 D-8
 PO Box 1516
 Elkins, WV 26241
 Attn: Debbie Barnett

WVDOT/Division of Highways
 D-9
 103 ½ Church Street
 Lewisburg, WV 24901
 Attn: Sherry Bostic

WVDOT/Division of Highways
 D-10
 270 Hardwood Lane
 Princeton, WV 24740
 Attn: Tommy Camden

L21 Series

360° ENCAPSULATED UNIFORM INTENSITY SUPER-LED® BEACONS



Certified SAE Class I beacons have a rated life that exceeds comparable flash tubes by more than 50:1.

The L21 utilizes new Broadband Energy Radiator™ Technology (patent pending). Solid-state beacons resemble traditional strobe beacons but have greater light output, lower amp draw, and longer life. These beacons feature generation 3.5 LED technology that rivals strobe in power.

L21LCP
Polycarbonate base, low dome.



L21HAM
Magnetic mount, high dome.



Cutaway showing encapsulation & light tower.

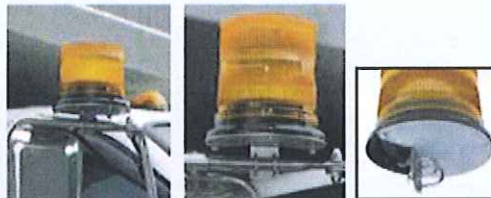

L21, high and low dome mirror mounts.

FEATURES

- Fully encapsulated electronics are moisture and vibration resistant.
- Certified SAE J845 Class, Class I 360° (amber).
- Select 12 or 24 VDC.
- 100,000 hour rated life.
- SmartLED® beacon design.
- High or low dome.
- Five-year warranty.
- Low current draw: 1.5 amp (peak), 0.6 amp (average) @ 12.8 VDC.
- Polycarbonate or cast aluminum base.
- Virtually no EMI radiation.

PERMANENT MOUNT MODELS

- Permanent mount features 24 Scan-Lock™ alternating and simultaneous flash patterns plus steady-burn.
- Combination mounting: 1" pipe, permanent or J-hook.
- Supplied with 6" pigtail.
- Synchronize with up to 8 beacons.
- Photocell Hi/Low mode available (contact factory).

MAGNETIC & MAGNETIC/SUCTION MOUNT MODELS

- 75 SignalAlert™ flashes per minute standard.
- Supplied with 10' straight cord and cigar plug with LED "ON" indicator On/Off switch and pattern selection switch.
- 12 VDC models.
- 80 lb. magnetic mounting base.
- Magnetic and magnetic/suction mount models do not include cruise light, low power or SYNC functions.

Available in Amber, and White/Clear

WHELEN®

L21 Series Beacon

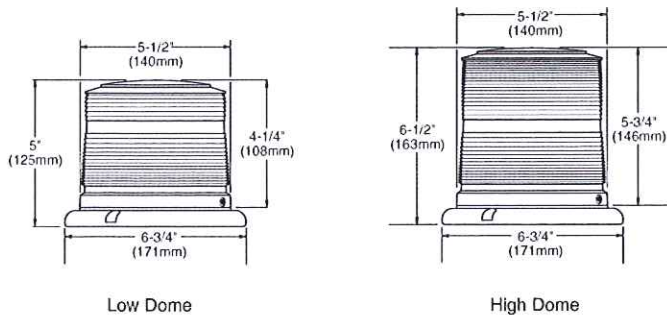

Low Dome

High Dome

L21 BEACONS HIGH DOME MODELS

- L21H*P.....Combination mount, polycarbonate base, 12 VDC
- L21H*M.....Magnetic mount, polycarbonate base, 12 VDC
- L21H*V.....Magnetic/suction mount, polycarbonate base, 12 VDC
- L21H*P4.....Combination mount, polycarbonate base, 24 VDC
- L21H*C.....Combination mount, cast aluminum base, 12 VDC

L21 BEACONS LOW DOME MODELS

- L21L*P.....Combination mount, polycarbonate base, 12 VDC
- L21L*M.....Magnetic mount, polycarbonate base, 12 VDC
- L21L*V.....Magnetic/suction mount, polycarbonate base, 12 VDC
- L21L*P4.....Combination mount, polycarbonate base, 24 VDC
- L21L*C.....Combination mount, cast aluminum base, 12 VDC

L21 OPTIONS

- MIRROR20.....Mirror mount bracket
- BBKT20.....Shelf mount bracket for L20/2500/2000 Series, stainless steel, mounts to flat verticle surface

REPLACEMENT PARTS

- DH2000*.....High Dome
- DL2000*.....Low Dome

Replace (*) in model number with letter indicating color choice: A = Amber, C = White/Clear.

Magnetic and magnetic/suction mount models do not include cruise light, low power or SYNC functions.

NOTE: The use of any magnetic or magnetic/suction mounted warning beacon on the vehicle while in motion, is at the discretion and risk of the user.

Available Scan-Lock™ Flash Patterns

L21 (24 patterns)

- SignalAlert™ 75 (Phase 1)
- SignalAlert 75 (Phase 2)
- CometFlash® 75 (Phase 1)
- CometFlash 75 (Phase 2)
- DoubleFlash 75 (Phase 1)
- DoubleFlash 75 (Phase 2)
- SingleFlash 75 (Phase 1)
- SingleFlash 75 (Phase 2)
- ComAlert™ 75 (Phase 1)
- ComAlert 75 (Phase 2)
- LongBurst™ 75 (Phase 1)
- LongBurst 75 (Phase 2)
- PingPong™ 75 (Phase 1)
- PingPong 75 (Phase 2)
- SingleFlash 60
- SingleFlash 90
- SingleFlash 120
- SingleFlash 300
- DoubleFlash 150
- ComAlert 150
- ActionFlash™ 1
- ActionFlash 2
- ModuFlash™
- ActionScan™
- Steady

Scan-Lock allows you to choose between available flash patterns.

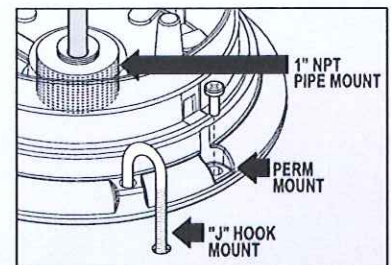

Combination Mounting

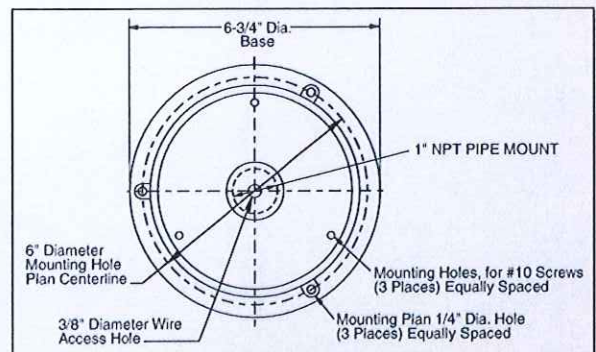

WHELEN
ENGINEERING COMPANY, INC.

51 Winthrop Road
Chester, Connecticut 06412-0684
(860) 526-9504 • Fax: (860) 526-4078
www.whelen.com

Whelen Engineering reserves the right to upgrade and improve products without notice.
© 2011 Whelen Engineering Company, Inc. Printed in U.S.A.
NASCAR® is a registered trademark of the National Association for Stock Car Auto Racing, Inc.
Code No. 11700L - 04/11

American Employees, American Manufacturing, American Pride!

WHELEN

L21 & L22 Series Encapsulated Super-LED® Beacons

Features:

- Combination mounting: permanent, pipe (1" NPT) and J-hook supplied with 6" pigtail.
- Virtually no EMI radiation.
- Combination mount available with photocell Hi/Low, contact factory.

Rated for 100,000 hours!

L21

- SAE Class 1 Certified (amber).
- 24 built-in Scan-Lock™ flash patterns plus SignalAlert™ default pattern.
- Magnetic mount supplied with 10' straight cord and cigar plug with LED indicator On/Off switch plus pattern control switch.

L22

- SAE Class 2 Certified (amber).
- 14 built-in Scan-Lock flash patterns plus SignalAlert default pattern.
- Magnetic mount supplied with 10' straight cord and cigar plug with LED indicator On/Off switch.

Warranty:

- LED = 5 year.

Models Replace asterisk in model number with desired color. A=Amber, C=White

Model No.	Mount	Profile	Base	Amps	FPM	VDC	SAE
L21H*P	combination	high	polycarbonate	1.5 / peak 0.60 / average 12 VDC	24 Scan-Lock patterns	12	J845 Class 1 360°
L21H*M	magnetic				SignalAlert		
L21H*V	magnetic/suction				24 Scan-Lock patterns		
L21L*P	combination	low			SignalAlert	12	
L21L*M	magnetic				24		
L21L*V	magnetic/suction				24		
L21L*P4	combination	high	cast aluminum	0.75 / peak 0.30 / average 24 VDC	24 Scan-Lock patterns	24	
L21H*C	combination				12		
L21H*C4					24		
L21L*C					12		
L21L*C4		24					
L22H*P	combination	high	polycarbonate	0.65 / peak 0.26 / average 12 VDC	14 Scan-Lock patterns	12	J845 Class 2 360°
L22H*M	magnetic				SignalAlert		
L22H*V	magnetic/suction				14 Scan-Lock patterns		
L22HAP4	combination	low			SignalAlert	12	
L22L*P	combination				24		
L22L*M	magnetic				14 Scan-Lock patterns		
L22L*V	magnetic/suction	24					
L22LAP4	combination						



Available Colors

Note: Magnetic and magnetic/suction mounts do not include synchronization capabilities.

Options

Model No.	Description
MIRROR20	West Coast mirror mount brackets
BGH	branch guard, high dome
BGL	branch guard, low dome

Replacement Parts

Dome
DH2000* (High)
DL2000* (Low)

Mounting

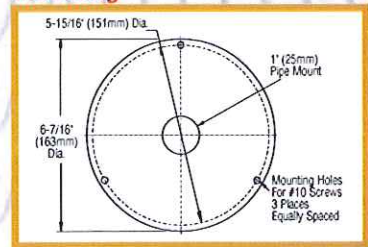

West Coast mirror mount brackets, mount directly on existing mirror brackets.

Dimensions

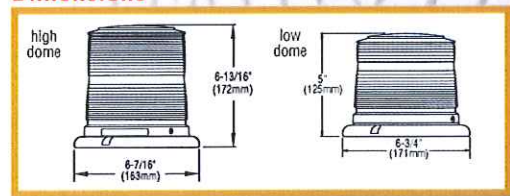

WHELEN® USER DIRECT WARRANTY (FOR AUTOMOTIVE PRODUCTS ONLY)

Whelen Engineering Company, Inc. warrants products of its manufacture against defects in material and workmanship. This is provided that the product has been installed and operated in accordance with the manufacturer's recommendations. During the warranty period (see below) the Factory Repair Center or an Authorized Whelen Repair Center† will repair or replace (at its option) any parts or electronic assemblies of the unit which disclose a defect in material or workmanship. The Repair Center will return the repaired unit, transportation cost prepaid.

The above warranty is between the first purchaser (ultimate user) only and Whelen Engineering Company, Inc. (manufacturer). No prior authorization is required for returning Whelen products for warranty consideration. Each Whelen product sold is covered only by the official warranty in effect at time of purchase.

This warranty is not applicable to any Whelen product that has failed due to abuse, misuse, improper installation, excessive voltages, or alterations to the product that affects, in the manufacturer's judgment, intended use and service. Whelen will not be held liable for any incidental or consequential damages, and assumes no responsibility or liability for expenses incurred in the removal and/or re-installation of products requiring service and/or repair; nor the packaging, handling, and shipping to the Factory Repair Center or Authorized Whelen Repair Center†; nor for the handling of products returned from the repair center after service or repair.

There are no other warranties, expressed or implied, including, but not limited to, any implied merchantability or fitness for a particular use. Whelen Engineering Company, Inc. reserves the right to modify this warranty statement at any time; or discontinue, modify, or upgrade any products of its manufacture with design improvements without prior notice.

*The use of magnetic or vacuum/suction mounted warning lights mounted on the roof or exterior of a vehicle in motion is at the sole discretion and risk of the user. Whelen Engineering makes no warranties or guarantees of equipment used in this way.

All power plugs/cigar plugs, incandescent and halogen bulbs, polycarbonate/plastic materials, radar products, aviation equipment, industrial products and high power voice/siren systems are not covered by this warranty (see applicable warranty statement).

*All Non-Whelen manufactured items that are sold by Whelen are covered by that manufacturer's warranty, and are excluded from this warranty statement (such as, GTT Emitters). This warranty will be void when using or substituting other than all-genuine Whelen system components, such as remote head assemblies, xenon flash tubes, shielded cables, strobe power supplies, siren amplifiers and siren speakers. This warranty gives you specific rights, and you may also have other rights which vary from state to state.

WHELEN ENGINEERING COMPANY ELECTRO-MECHANICAL AND STROBE PRODUCTS

STANDARD / 2 YEAR WARRANTY

Whelen products are covered by a direct warranty for up to a maximum two years from date of purchase (not to exceed three years from date of manufacture), with proof of purchase. In accordance with the policy statement described herein, the unit may be returned directly to the factory or to an Authorized Whelen Repair Center† for warranty consideration. Whelen siren speakers, when used with a Whelen siren amplifier, are covered by a 2 year warranty from the date of manufacture. Heavy-Duty motor assemblies (so marked) are covered by a direct warranty for up to three years from date of manufacture. For warranty consideration, both the siren speakers and motor assemblies are subject to the conditions and steps described herein.

HDP® / 5 YEAR WARRANTY

Whelen Automotive Non-Lightbar Strobe Power Supplies, LED Ballasts and LED Products bearing the official HDP label and manufactured to HDP standards, are covered by a direct warranty for up to five years from date of manufacture. In accordance with the policy statement described herein, the unit may be returned directly to the factory or to an Authorized Whelen Repair Center† for warranty consideration.



12 MONTH WARRANTY — BACK-UP ALARMS

Whelen Back-Up Alarms are covered by a 12 month warranty and are subject to the conditions and steps described herein.

10 YEAR LIMITED WARRANTY — LIGHTBAR POWER SUPPLY

All repairable warranty and non-warranty Edge® style lightbar strobe power supplies will be replaced with a compatible new power supply. If out of initial warranty period but less than 7 years old, the charge will be a flat fee of \$143.00; if between 7 & 10 years old, the charge will be a flat fee of \$160.00 (warranty for standard power supply is 2 years and HDP® Heavy-Duty Professional power supply is 5 years). This is subject to the conditions and steps described herein.

12 AND 24 MONTH DIRECT WARRANTY — XENON FLASH TUBES

(Except Flash Tubes from 1000/1500/2000/3000 & VP Series which are covered by a 6 Month Warranty)

If the xenon flash tube component of a "Whelen" brand (not from 1000/1500/2000/3000 or VP Series) product is returned to Whelen within 12 months of the date which is affixed to the flash tube, Whelen will replace that flash tube free of charge ONE TIME ONLY, subject to the conditions and steps herein. Whelen "Gold Medallion" flash tubes including all linear flash tube assemblies, carry a 24 month warranty. Whelen will pay ground transportation from Whelen's factory or Authorized Whelen Repair Center† to the customer via UPS where available (in the Continental U.S.).

12 MONTH EXTENDED WARRANTY — WHELEN REPAIRED STROBE POWER SUPPLIES

Whelen offers to repair or replace, free of charge, any part of its strobe light power supplies that have been repaired by Whelen within 12 months and are less than 5 years old, subject to the conditions and steps herein. Whelen will pay ground transportation from Whelen's factory or Authorized Whelen Repair Center† to the customer via UPS where available (in the Continental U.S.).

WHELEN ENGINEERING COMPANY OUT-OF-WARRANTY FACTORY REPAIR PROGRAM:

If found to be repairable, the Whelen Factory Repair Center (only) will repair Non-Lightbar Electronic Strobe Power Supplies for \$88 each. This does not include replacement of any other electro-mechanical parts including flash tubes, polycarbonate domes, motors, or hardware items.

Follow the "Steps To Be Taken For Return" noted below, and include a check or money order for \$88 for each unit returned. For Whelen products older than 10 years, repair charges will be determined upon examination only (minimum charge is \$160). Contact factory service center for further details.

STEPS TO BE TAKEN FOR WARRANTY RETURN:

- 1) Whelen products are to be returned freight prepaid to the: Whelen Factory Repair Center Building B, 51 Winthrop Road, Chester, CT 06412-0684; or an Authorized Whelen Repair Center†. Do not ship by bus.
- 2) A copy of the sales receipt must be returned with the defective unit to qualify for warranty coverage from date of purchase.
- 3) Include a short statement explaining the problem.
- 4) Include your name, address, and day-time telephone number.
- 5) Whelen and its Authorized Repair Centers will, via UPS, ship back the repaired unit freight prepaid, usually within a few days after its receipt.

WHELEN®

ENGINEERING COMPANY, INC.

51 Winthrop Road
Chester, CT 06412-0684
Phone: (860) 526-9504
Fax: (860) 526-4078
www.whelen.com

— EFFECTIVE 10/1/11, REPLACES ALL PREVIOUSLY PUBLISHED SERVICE POLICIES —

† The only AUTHORIZED WHELEN REPAIR CENTER(S) are predetermined by the Whelen Factory via official listing obtained from Whelen Engineering Company, Chester, CT.

*New/Revised

10250V-092211

© 2011 Whelen.

WHELEN[®]
ENGINEERING COMPANY, INC.
Technical Research Testing Laboratory

Rt. 145, Chester, CT 06412
Phone : 860-526-9504
Fax : 860-526-4078

Certificate of Compliance

This notice verifies that the item below has been tested by an AMECA accredited laboratory and has been found to be in compliance with the jurisdictional standard(s) listed below where applicable.

ITEM : L21 12V WHT/AMB HIGH POLY PERM
Model : L21HAP

Meets photometry of jurisdictional compliance standard(s) identical to:

- J845 Dec07 Amb C1 Cds/Min
- J845 Dec07 Amb C1 Peak
- J845 MAY97 CLASS1 YELLOW

Test Equipment : Hoffman Automated Goniophotometer System

The above test equipment meets the guidelines of J1330, and has been calibrated by Hoffman Engineering Corp. with accuracies traceable to the National Institute of Standards and Technology.



Photometric Laboratory Supervisor



AMECA
Accredited
Laboratory

WHELEN[®]
ENGINEERING COMPANY, INC.
Technical Research Testing Laboratory

Rt. 145, Chester, CT 06412
Phone : 860-526-9504
Fax : 860-526-4078

Certificate of Compliance

This notice verifies that the item below has been tested by an AMECA accredited laboratory and has been found to be in compliance with the jurisdictional standard(s) listed below where applicable.

ITEM : L21 12V WHT/AMB HIGH POLY PERM
Model : L21HAP

Meets photometry of jurisdictional compliance standard(s) identical to:

- J845 Dec07 Amb C1 Cds/Min
- J845 Dec07 Amb C1 Peak
- J845 MAY97 CLASS1 YELLOW

Test Equipment : Hoffman Automated Goniophotometer System

The above test equipment meets the guidelines of J1330, and has been calibrated by Hoffman Engineering Corp. with accuracies traceable to the National Institute of Standards and Technology.



Photometric Laboratory Supervisor



AMECA
Accredited
Laboratory

State of West Virginia
VENDOR PREFERENCE CERTIFICATE

Certification and application* is hereby made for Preference in accordance with *West Virginia Code*, §5A-3-37. (Does not apply to construction contracts). *West Virginia Code*, §5A-3-37, provides an opportunity for qualifying vendors to request (at the time of bid) preference for their residency status. Such preference is an evaluation method only and will be applied only to the cost bid in accordance with the *West Virginia Code*. This certificate for application is to be used to request such preference. The Purchasing Division will make the determination of the Resident Vendor Preference, if applicable.

1. Application is made for 2.5% resident vendor preference for the reason checked:

- Bidder is an individual resident vendor and has resided continuously in West Virginia for four (4) years immediately preceding the date of this certification; or,
 Bidder is a partnership, association or corporation resident vendor and has maintained its headquarters or principal place of business continuously in West Virginia for four (4) years immediately preceding the date of this certification; or 80% of the ownership interest of Bidder is held by another individual, partnership, association or corporation resident vendor who has maintained its headquarters or principal place of business continuously in West Virginia for four (4) years immediately preceding the date of this certification; or,
 Bidder is a nonresident vendor which has an affiliate or subsidiary which employs a minimum of one hundred state residents and which has maintained its headquarters or principal place of business within West Virginia continuously for the four (4) years immediately preceding the date of this certification; or,

2. Application is made for 2.5% resident vendor preference for the reason checked:

- Bidder is a resident vendor who certifies that, during the life of the contract, on average at least 75% of the employees working on the project being bid are residents of West Virginia who have resided in the state continuously for the two years immediately preceding submission of this bid; or,

3. Application is made for 2.5% resident vendor preference for the reason checked:

- Bidder is a nonresident vendor employing a minimum of one hundred state residents or is a nonresident vendor with an affiliate or subsidiary which maintains its headquarters or principal place of business within West Virginia employing a minimum of one hundred state residents who certifies that, during the life of the contract, on average at least 75% of the employees or Bidder's affiliate's or subsidiary's employees are residents of West Virginia who have resided in the state continuously for the two years immediately preceding submission of this bid; or,

4. Application is made for 5% resident vendor preference for the reason checked:

- Bidder meets either the requirement of both subdivisions (1) and (2) or subdivision (1) and (3) as stated above; or,

5. Application is made for 3.5% resident vendor preference who is a veteran for the reason checked:

- Bidder is an individual resident vendor who is a veteran of the United States armed forces, the reserves or the National Guard and has resided in West Virginia continuously for the four years immediately preceding the date on which the bid is submitted; or,

6. Application is made for 3.5% resident vendor preference who is a veteran for the reason checked:

- Bidder is a resident vendor who is a veteran of the United States armed forces, the reserves or the National Guard, if, for purposes of producing or distributing the commodities or completing the project which is the subject of the vendor's bid and continuously over the entire term of the project, on average at least seventy-five percent of the vendor's employees are residents of West Virginia who have resided in the state continuously for the two immediately preceding years.

Bidder understands if the Secretary of Revenue determines that a Bidder receiving preference has failed to continue to meet the requirements for such preference, the Secretary may order the Director of Purchasing to: (a) reject the bid; or (b) assess a penalty against such Bidder in an amount not to exceed 5% of the bid amount and that such penalty will be paid to the contracting agency or deducted from any unpaid balance on the contract or purchase order.

By submission of this certificate, Bidder agrees to disclose any reasonably requested information to the Purchasing Division and authorizes the Department of Revenue to disclose to the Director of Purchasing appropriate information verifying that Bidder has paid the required business taxes, provided that such information does not contain the amounts of taxes paid nor any other information deemed by the Tax Commissioner to be confidential.

Under penalty of law for false swearing (*West Virginia Code*, §61-5-3), Bidder hereby certifies that this certificate is true and accurate in all respects; and that if a contract is issued to Bidder and if anything contained within this certificate changes during the term of the contract, Bidder will notify the Purchasing Division in writing immediately.

Bidder: Electronic Communications of WV

Signed: _____

Date: Sept 27 2011

Title: President

RFQ No. 7012C004

STATE OF WEST VIRGINIA
Purchasing Division

PURCHASING AFFIDAVIT

West Virginia Code §5A-3-10a states: No contract or renewal of any contract may be awarded by the state or any of its political subdivisions to any vendor or prospective vendor when the vendor or prospective vendor or a related party to the vendor or prospective vendor is a debtor and the debt owned is an amount greater than one thousand dollars in the aggregate

DEFINITIONS:

"Debt" means any assessment, premium, penalty, fine, tax or other amount of money owed to the state or any of its political subdivisions because of a judgment, fine, permit violation, license assessment, defaulted workers' compensation premium, penalty or other assessment presently delinquent or due and required to be paid to the state or any of its political subdivisions, including any interest or additional penalties accrued thereon.

"Debtor" means any individual, corporation, partnership, association, Limited Liability Company or any other form or business association owing a debt to the state or any of its political subdivisions. "Political subdivision" means any county commission; municipality; county board of education; any instrumentality established by a county or municipality; any separate corporation or instrumentality established by one or more counties or municipalities, as permitted by law; or any public body charged by law with the performance of a government function or whose jurisdiction is coextensive with one or more counties or municipalities. "Related party" means a party, whether an individual, corporation, partnership, association, limited liability company or any other form or business association or other entity whatsoever, related to any vendor by blood, marriage, ownership or contract through which the party has a relationship of ownership or other interest with the vendor so that the party will actually or by effect receive or control a portion of the benefit, profit or other consideration from performance of a vendor contract with the party receiving an amount that meets or exceeds five percent of the total contract amount.

EXCEPTION: The prohibition of this section does not apply where a vendor has contested any tax administered pursuant to chapter eleven of this code, workers' compensation premium, permit fee or environmental fee or assessment and the matter has not become final or where the vendor has entered into a payment plan or agreement and the vendor is not in default of any of the provisions of such plan or agreement.

Under penalty of law for false swearing (*West Virginia Code* §61-5-3), it is hereby certified that the vendor affirms and acknowledges the information in this affidavit and is in compliance with the requirements as stated.

WITNESS THE FOLLOWING SIGNATURE

Vendor's Name: Electronic Communications of WV Inc.

Authorized Signature: [Signature] Date: Sept 27 2011

State of West Virginia

County of Kanawha, to-wit:

Taken, subscribed, and sworn to before me this 27 day of September, 2011.

My Commission expires May 10, 2020.

AFFIX SEAL HERE

NOTARY PUBLIC

[Signature]

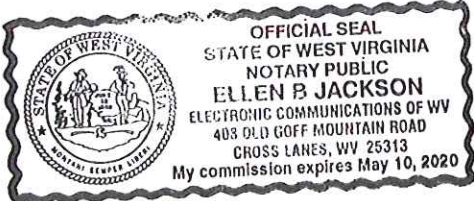

Please use this document for technical questions, posing in question format.

Technical Questions for RFQ: 7012004

Vendor Name: Electronic Communications of WV Inc

Questions:

1. Specifications

NONE

2 Delivery

NONE

3 Invoicing

NONE

4 Award

NONE

Other:

NONE