



State of West Virginia  
 Department of Administration  
 Purchasing Division  
 2019 Washington Street East  
 Post Office Box 50130  
 Charleston, WV 25305-0130

# Request for Quotation

RFQ NUMBER  
 08120198

PAGE  
 1

ADDRESS CORRESPONDENCE TO ATTENTION OF:  
 PAUL REYNOLDS  
 304-558-0468

RFQ COPY

TYPE NAME/ADDRESS HERE

VENDOR

Charleston Steel  
 511 28th Street  
 Dunbar, WV. 25064

SHIP TO

DIVISION OF HIGHWAYS

1101 NORTH RANDOLPH  
 ELKINS, WV  
 26241

Q12-006

DATE PRINTED 12/16/2011	TERMS OF SALE NET 30/OR VISA	SHIP VIA C.C.	F.O.B. ELKINS	FREIGHT TERMS PREPAID
BID OPENING DATE: 01/11/2012		BID OPENING TIME 01:30PM		

LINE	QUANTITY	UOP	CAT. NO.	ITEM NUMBER	UNIT PRICE	AMOUNT
0001		LB		570-76	LOT	\$59,824.71
STEEL BARS, REINFORCING						
REQUEST FOR QUOTATION						
THE WEST VIRGINIA STATE PURCHASING DIVISION FOR THE AGENCY, THE WEST VIRGINIA DIVISION OF HIGHWAYS IS SOLICITING BIDS FOR GALVANIZED STRUCTURAL STEEL AND REINFORCING STEEL PER THE ATTACHED SPECIFICATIONS.						
PREFERENCE FOR USE OF DOMESTIC STEEL PRODUCTS						
1. EXCEPT WHEN AUTHORIZED BY THE DIRECTOR OF THE PURCHASING DIVISION PURSUANT TO SUBSECTION 2 BELOW, NO CONTRACTOR MAY USE OR SUPPLY STEEL PRODUCTS FOR A STATE CONTRACT PROJECT OTHER THAN THOSE STEEL PRODUCTS MADE IN THE UNITED STATES. AS USED USED IN THIS CONTRACT,						
A. "STATE CONTRACT PROJECT" MEANS ANY ERECTION OR CONSTRUCTION OF, OR ANY ADDITION TO, ALTERATION OF OR OTHER IMPROVEMENT TO ANY BUILDING OR STRUCTURE, INCLUDING, BUT NOT LIMITED TO, ROADS OR HIGHWAYS, OR THE INSTALLATION OF ANY HEATING OR COOLING OR VENTILATING PLANTS OR OTHER EQUIPMENT, OR THE SUPPLY OF AND MATERIALS FOR SUCH PROJECTS, PURSUANT TO A CONTRACT WITH THE STATE OF WEST VIRGINIA FOR WHICH BIDS WERE SOLICITED ON OR AFTER JUNE 6, 2001.						
B. "STEEL PRODUCTS" MEANS PRODUCTS ROLLED, FORMED						



SEE REVERSE SIDE FOR TERMS AND CONDITIONS

SIGNATURE <i>Dennis Nicholas</i>	TELEPHONE 304-766-6607	DATE 1/10/12
TITLE <i>Mgr Warehouse</i>	FEIN 20-5496272	ADDRESS CHANGES TO BE NOTED ABOVE

WHEN RESPONDING TO RFQ INSERT NAME AND ADDRESS IN SPACE ABOVE LABEL ED 'VENDOR'



State of West Virginia  
 Department of Administration  
 Purchasing Division  
 2019 Washington Street East  
 Post Office Box 50130  
 Charleston, WV 25305-0130

# Request for Quotation

RFQ NUMBER  
 08120198

PAGE  
 2

ADDRESS CORRESPONDENCE TO ATTENTION OF:  
 PAUL REYNOLDS  
 304-558-0468

RFQ COPY

TYPE NAME/ADDRESS HERE

**CHARLESTON STEEL**

VENDOR

DIVISION OF HIGHWAYS

1101 NORTH RANDOLPH  
 ELKINS, WV  
 26241

SHIP TO

DATE PRINTED 12/16/2011	TERMS OF SALE <b>NET 30/ORVISA</b>	SHIP VIA <b>C.C</b>	F.O.B. <b>ELKINS</b>	FREIGHT TERMS <b>PREPAID</b>
BID OPENING DATE: 01/11/2012		BID OPENING TIME 01:30PM		

LINE	QUANTITY	UOP	CAT NO	ITEM NUMBER	UNIT PRICE	AMOUNT
				SHAPED, DRAWN, EXTRUDED, FORGED, CAST, FABRICATED OR OTHERWISE SIMILARLY PROCESSED, OR PROCESSED BY A COMBINATION OF TWO OR MORE OF SUCH OPERATIONS, FROM STEEL MADE BY THE OPEN HEARTH, BASIC OXYGEN, ELECTRIC FURNACE, BESSEMER OR OTHER STEEL MAKING PROCESS.		
				C. "UNITED STATES" MEANS THE UNITED STATES OF AMERICA AND INCLUDES ALL TERRITORY, CONTINENTAL OR INSULAR, SUBJECT TO THE JURISDICTION OF THE UNITED STATES.		
				2. THE DIRECTOR OF THE PURCHASING DIVISION MAY, IN WRITING, AUTHORIZE THE USE OF FOREIGN STEEL PRODUCTS IF:		
				A. THE COST FOR EACH CONTRACT ITEM USED DOES NOT EXCEED ONE TENTH OF ONE PERCENT (.1%) OF THE TOTAL CONTRACT COST OR TWO THOUSAND FIVE HUNDRED DOLLARS (2,500.00), WHICHEVER IS GREATER. FOR THE PURPOSES OF THIS SECTION, THE COST IS THE VALUE OF THE STEEL PRODUCT AS DELIVERED TO THE PROJECT OR,		
				B. THE DIRECTOR OF THE PURCHASING DIVISION DETERMINES THAT SPECIFIED STEEL MATERIALS ARE NOT PRODUCED IN THE UNITED STATES IN SUFFICIENT QUANTITY OR OTHERWISE ARE NOT REASONABLY AVAILABLE TO MEET CONTRACT REQUIREMENTS.		
				3. A CONTRACTOR WHO USES STEEL PRODUCTS IN VIOLATION OF THIS SECTION MAY BE SUBJECT TO CIVIL PENALTIES PURSUANT TO WV CODE SECTION 5A-3-56.		
				REV. 10/01/01		

SEE REVERSE SIDE FOR TERMS AND CONDITIONS

SIGNATURE <i>Rennir Nicholas</i>	TELEPHONE 304-766-6607	DATE 1/10/12
TITLE <i>Mgr Warehouse</i>	FEIN 20-5496272	ADDRESS CHANGES TO BE NOTED ABOVE



State of West Virginia  
 Department of Administration  
 Purchasing Division  
 2019 Washington Street East  
 Post Office Box 50130  
 Charleston, WV 25305-0130

# Request for Quotation

RFO NUMBER
08120198

PAGE
3

ADDRESS CORRESPONDENCE TO ATTENTION OF:
PAUL REYNOLDS
304-558-0468

RFQ COPY

TYPE NAME/ADDRESS HERE

**CHARLESTON STEEL**

VENDOR

DIVISION OF HIGHWAYS

SHIP TO

1101 NORTH RANDOLPH  
 ELKINS, WV  
 26241

DATE PRINTED	TERMS OF SALE	SHIP VIA	F.O.B.	FREIGHT TERMS
12/16/2011	NET 30/DR VISA	C.C.	ELKINS	PREPAID

BID OPENING DATE: 01/11/2012 BID OPENING TIME 01:30PM

LINE	QUANTITY	UOP	CAT. NO.	ITEM NUMBER	UNIT PRICE	AMOUNT
<p>PURCHASING CARD ACCEPTANCE: THE STATE OF WEST VIRGINIA CURRENTLY UTILIZES A VISA PURCHASING CARD PROGRAM WHICH IS ISSUED THROUGH A BANK. THE SUCCESSFUL VENDOR MUST ACCEPT THE STATE OF WEST VIRGINIA VISA PURCHASING CARD FOR PAYMENT OF ALL ORDERS PLACED BY ANY STATE AGENCY AS A CONDITION OF AWARD.</p> <p style="text-align: center;">NOTICE</p> <p>A SIGNED BID MUST BE SUBMITTED TO:</p> <p style="text-align: center;">DEPARTMENT OF ADMINISTRATION          PURCHASING DIVISION          BUILDING 15          2019 WASHINGTON STREET, EAST          CHARLESTON, WV 25305-0130</p> <p>THE BID SHOULD CONTAIN THIS INFORMATION ON THE FACE OF THE ENVELOPE OR THE BID MAY NOT BE CONSIDERED:</p> <p>SEALED BID</p> <p>BUYER: PAUL REYNOLDS FILE 33</p> <p>RFQ. NO.: 08120198</p> <p>BID OPENING DATE: 01/11/2012</p> <p>BID OPENING TIME: 1:30 P.M.</p> <p>PLEASE PROVIDE A FAX NUMBER IN CASE IT IS NECESSARY TO CONTACT YOU REGARDING YOUR BID:</p> <p style="text-align: center;">304-766-6603</p>						

SEE REVERSE SIDE FOR TERMS AND CONDITIONS

SIGNATURE <i>W. Dennis Nicholas</i>	TELEPHONE 304-766-6607	DATE 1/10/12
TITLE <i>Mgr. Warehouse Sales</i>	FEIN 20-5496272	ADDRESS CHANGES TO BE NOTED ABOVE

WHEN RESPONDING TO RFQ, INSERT NAME AND ADDRESS IN SPACE ABOVE LABELED 'VENDOR'



State of West Virginia  
 Department of Administration  
 Purchasing Division  
 2019 Washington Street East  
 Post Office Box 50130  
 Charleston, WV 25305-0130

# Request for Quotation

RFQ NUMBER
08120198

PAGE
4

ADDRESS CORRESPONDENCE TO ATTENTION OF:
PAUL REYNOLDS
304-558-0468

RFQ COPY

TYPE NAME/ADDRESS HERE

**CHARLESTON STEEL**

VENDOR

DIVISION OF HIGHWAYS

1101 NORTH RANDOLPH  
 ELKINS, WV  
 26241

SHIP TO

DATE PRINTED 12/16/2011	TERMS OF SALE <b>NET 30/OR VISA</b>	SHIP VIA <b>C.C</b>	F.O.B. <b>ELKINS</b>	FREIGHT TERMS <b>PREPAID</b>
BID OPENING DATE: 01/11/2012		BID OPENING TIME 01:30PM		

LINE	QUANTITY	UOP	CAT. NO.	ITEM NUMBER	UNIT PRICE	AMOUNT
CONTACT PERSON (PLEASE PRINT CLEARLY):						
----- <b>DENNIS NICHOLAS</b> -----						
***** THIS IS THE END OF RFQ 08120198 *****						<b>TOTAL: \$59,824.71</b>

SEE REVERSE SIDE FOR TERMS AND CONDITIONS

SIGNATURE <i>Dennis Nicholas</i>	TELEPHONE 304-766-6607	DATE 1/10/12
TITLE <i>Mgr Warehouse</i>	FEIN 20-5496272	ADDRESS CHANGES TO BE NOTED ABOVE

WHEN RESPONDING TO RFQ, INSERT NAME AND ADDRESS IN SPACE ABOVE LABELED 'VENDOR'

## 08120198 Specifications

Purpose: To provide the West Virginia Division of Highways with Structural Steel and Reinforcing Steel Bars to be used on Project # S347-39-2.09, Pleasant Run #2 Bridge and Project # S336-21/6-0.03, Dead Owl Bridge.

### 1.0 DEFINITIONS

- A. The "Agency" shall be defined as the West Virginia Division of Highways
- B. The "Vendor" shall be defined as the successful bidder.
- C. The "Purchase Order" shall be defined as the binding agreement that is entered into between the State of West Virginia and the Vendor to provide the services as herein specified.
- D. "Mandatory Requirements: The terms "must", "will", "shall", "minimum", "maximum", or "is/are required" identify a mandatory item or factor. Decisions regarding compliance with any mandatory requirements shall be at the sole discretion of the State.

### 2.0 SCOPE OF WORK

The successful Vendor shall provide Structural and Reinforcing Steel as described and detailed.

#### 2.1 Technical Requirements:

All Structural and Reinforcing steel provided shall be in accordance with West Virginia Division of Highways Standard Specifications Roads and Bridges, adopted 2010 and the current Supplemental Specifications and the attached control prints.

[www.transportation.wv.gov/highways/engineering/Pages/publications.aspx](http://www.transportation.wv.gov/highways/engineering/Pages/publications.aspx)

All galvanizing shall be in accordance with AASHTO M111. Steel designated as AASHTO M270 shall conform to Section S4, Non-Fracture-Critical, Zone 2, toughness testing and requirements.

## 2.2 Freight

2.2.1 All shipments are to be FOB Destination.

2.2.2 The Vendor shall be responsible for all costs associated with delivery of materials.

## 2.3 Delivery

2.3.1 Deliveries shall be made to:

WVDOH District Eight  
1101 North Randolph Avenue  
Elkins, WV 26241

2.3.2 Delivery is requested by April 1, 2012. Vendor shall coordinate delivery with the District Bridge Engineer @ 304-637-0220.

2.3.3 The Vendor shall notify the District Storekeeper @ 304-637-0226, 48 hours in advance of delivery to provide necessary personnel and equipment for unloading.

2.3.4 Delivery will only be accepted during normal working hours 7:30 am to 4:00 pm, Monday – Friday.

2.3.5 Delivery is an integral part of this purchase order and failure to comply will be cause to initiate a WV-82, Vendor Performance Form. This form will officially notify the West Virginia Division of Purchasing and the Vendor of unsatisfactory performance in the execution of this purchase order and the requirements herein.

### 3 INVOICING

#### 3.1 Payment

3.1.1 The Vendor must send an invoice to:  
West Virginia Division of Highways, District Eight  
P.O. Box 1516  
Elkins, WV 26241  
Attention: Henry Currence

#### 3.2 Partial Payment of Approved Structural and Reinforcing Steel

3.2.1 Upon completion of manufacture and approval by the Division of Highways of all steel specified on the purchase order, the vendor may invoice and the Division will pay for the cost of manufacturing the steel, not to exceed 65% of the total cost of the delivered steel. The remaining, 35% or more, may be invoiced when all the steel is delivered. Partial payment for steel shall be subject of the following conditions:

- a. The vendor must request partial payment and furnish an official invoice for the manufactured and approved steel.
- b. The partial payment invoice shall be accompanied by a surety bond equal to the invoiced amount guaranteeing delivery of all items specified on the purchase order.
- c. The vendor shall furnish a statement of approved steels' condition and exact storage location.
- d. The vendor shall furnish a legal right-of-entry onto the storage site to Division of Highways' employees and/or agents for the purpose of inspecting, sampling, testing, and removing any or all steel.
- e. The vendor shall certify that the stored steel is suitably marked and identified as property of the Division of Highways and will not be used for any purpose not designated by the Division.

### 4 AWARD

Purchase order will be awarded complete and not split.

WV DEPT. OF TRANSPORTATION - DIVISION OF HIGHWAYS  
DISTRICT 8, P.O. BOX 1516  
ELKINS, WV 26241

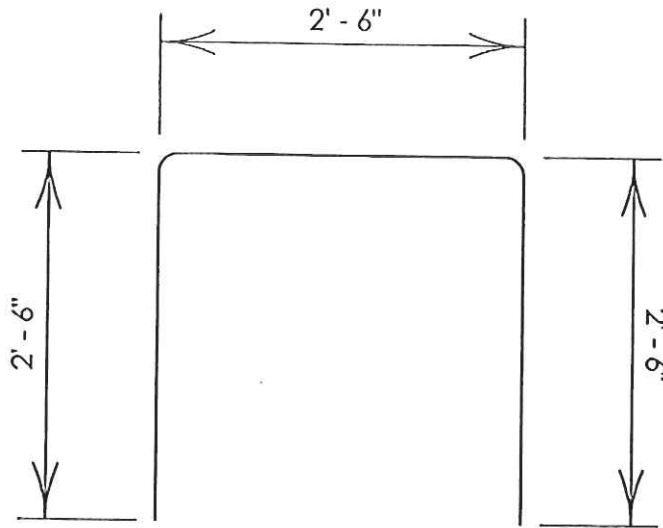

MARK A601  
GALVANIZED  
#6 STEEL REINFORCING BAR  
AASHTO M31 (GRADE 60)

400 Required @ 7' - 6"  
3000 x 1.502 lb/ft  
= 4506 lb

RFQ NO. 08120198  
SKETCH #1



WV DEPT. OF TRANSPORTATION - DIVISION OF HIGHWAYS  
DISTRICT 8, P.O. BOX 1516  
ELKINS, WV 26241

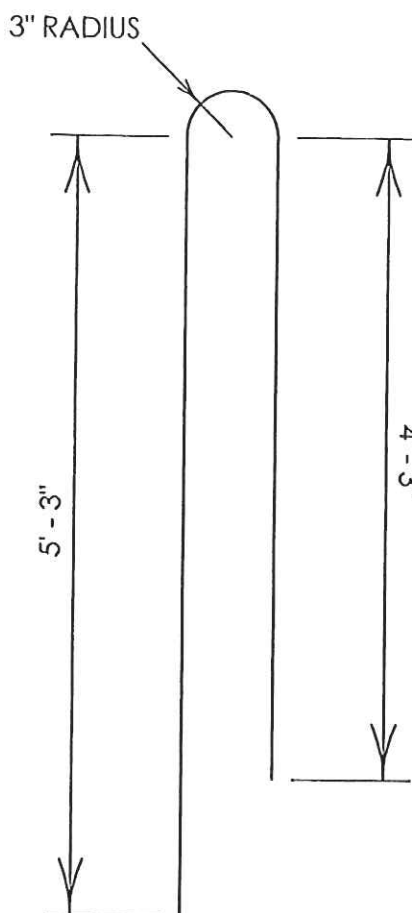

MARK A602  
GALVANIZED  
#6 STEEL REINFORCING BAR  
AASHTO M31 (GRADE 60)

400 Required @ 10' - 3 1/2"  
4116.67 x 1.502 lb/ft  
= 6183 lb

RFQ NO. 08120198  
SKETCH #2

WV DEPT. OF TRANSPORTATION - DIVISION OF HIGHWAYS  
DISTRICT 8, P.O. BOX 1516  
ELKINS, WV 26241

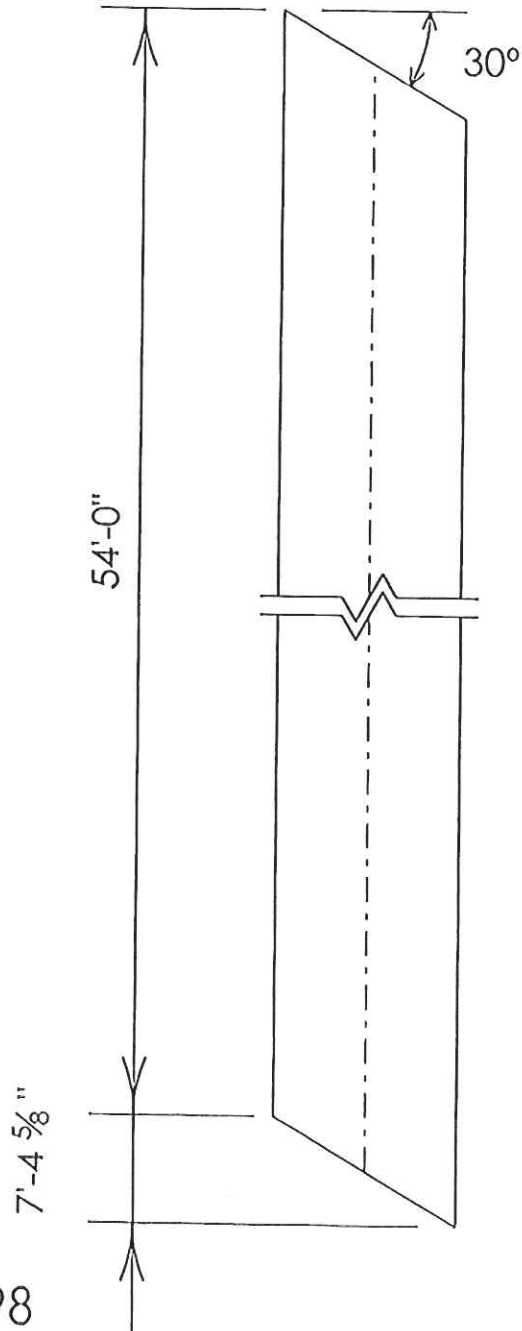

GALVANIZED W24x17 BEAM (Grade 50)  
3 Required

RFQ NO. 08120198  
SKETCH #3

WV DEPT. OF TRANSPORTATION - DIVISION OF HIGHWAYS  
DISTRICT 8, P.O. BOX 1516  
ELKINS, WV 26241

ALL HOLES  $1\frac{3}{16}$ " DIAMETER

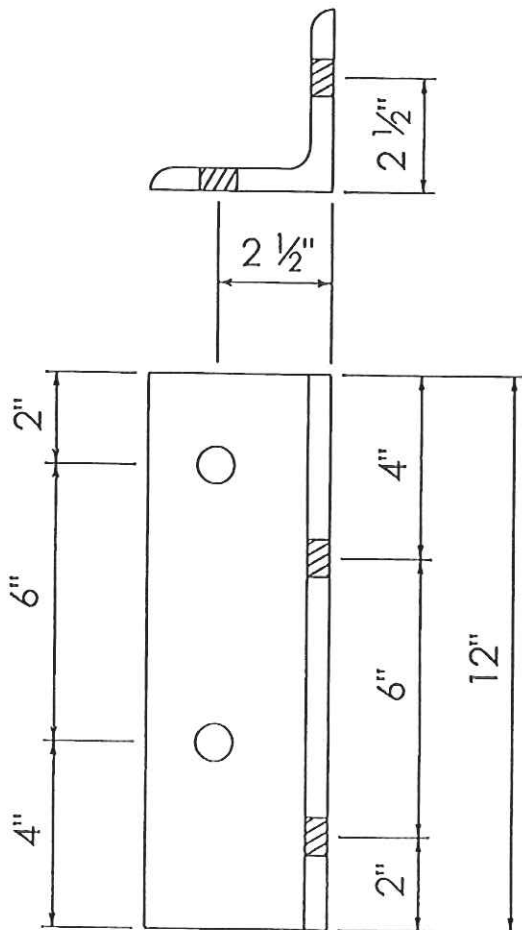

GALVANIZED CLIP ANGLE

ANGLE 4" x 4" x 1/2" - 24 REQUIRED

RFQ NO. 08120198  
SKETCH #4

WV DEPT. OF TRANSPORTATION - DIVISION OF HIGHWAYS  
DISTRICT 8, P.O. BOX 1516  
ELKINS, WV 26241

ALL HOLES  $1\frac{3}{16}$ " DIAMETER

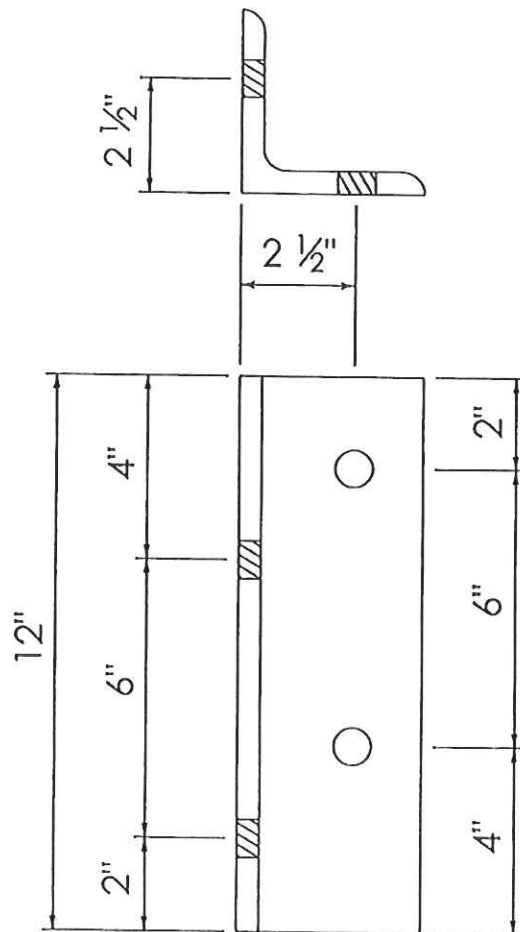

GALVANIZED CLIP ANGLE

ANGLE 4" x 4" x  $\frac{1}{2}$ " - 2 REQUIRED

RFQ NO. 08120198  
SKETCH #5

WV DEPT. OF TRANSPORTATION - DIVISION OF HIGHWAYS  
 DISTRICT 8, P.O. BOX 1516  
 ELKINS, WV 26241

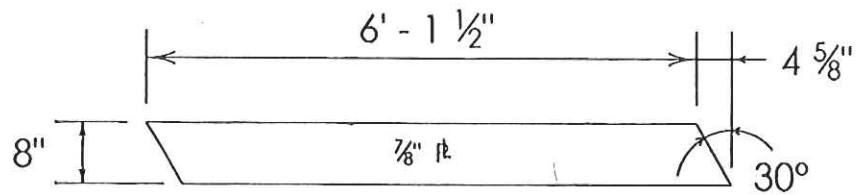

GALVANIZED  $\frac{7}{8}''$  PLATE - MARK P1  
 (2 Required)

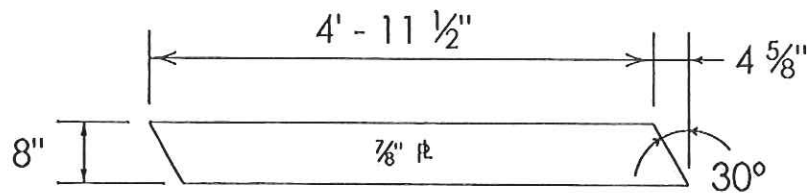

GALVANIZED  $\frac{7}{8}''$  PLATE - MARK P2  
 (2 Required)

RFQ NO. 08120198  
 SKETCH #6

WV DEPT. OF TRANSPORTATION - DIVISION OF HIGHWAYS  
DISTRICT 8, P.O. BOX 1516  
ELKINS, WV 26241

ALL HOLES  $1\frac{3}{16}$ " DIAMETER

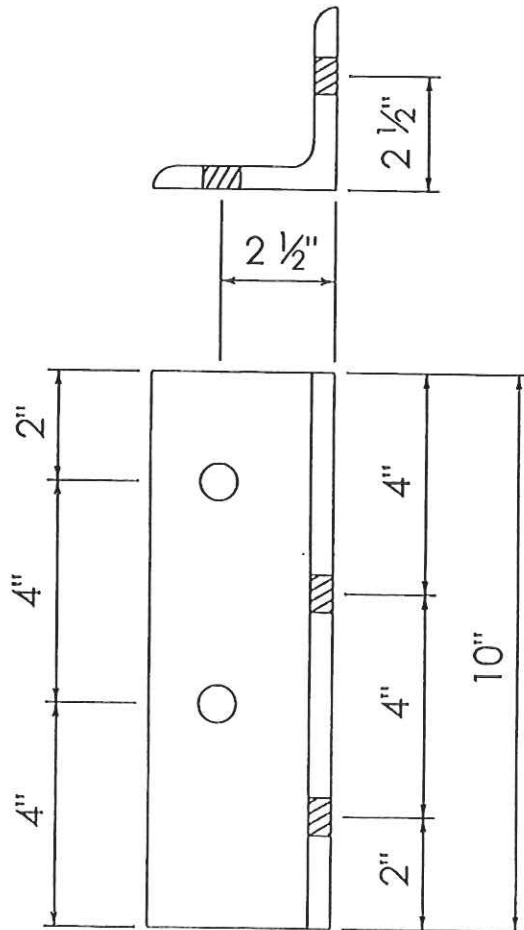

GALVANIZED CLIP ANGLE

ANGLE 4" x 4" x 1/2" - 54 REQUIRED

45'

RFQ NO. 08120198  
SKETCH #7

**Cost Sheet**  
**RFQ #08120198**

Item Number	Quantity	Description	Unit Price	Amount
1	4506	lb - Galvanized #6 Steel Reinforcing Bar AASHTO M31, Grade 60 Ship 400 pcs fabricated in accordance with Mark 601 on Sketch #1	1.31	\$5902.86
2	6183	lb - Galvanized #6 Steel Reinforcing Bar AASHTO M31, Grade 60 Ship 400 pcs fabricated in accordance with Mark 602 on Sketch <del>#1</del> #2	1.31	\$8099.73
3	18,954	lb - W24x117, Galvanized W-shaped Structural Steel, AASHTO M270, Grade 50 Ship 3 pcs @ 54'-0" fabricated in accordance with Sketch #3	1.01	\$19,143.54
4	640	lb - L 4"x4"x 1/2" (12.8#/LF) Galvanized Structural Steel Angle, AASHTO M270, Grade 50 Ship 50 pcs @ 1'-0" fabricated in accordance with Sketch #4	2.68	\$ 1715.20
5	26	lb - L 4"x4"x 1/2" (12.8#/LF) Galvanized Structural Steel Angle, AASHTO M270, Grade 50 Ship 2 pcs @ 1'-0" fabricated in accordance with Sketch #5	2.68	\$ 69.68
6	292	lb - 7/8" x 8" Galvanized Structural Steel Bar (23.8 #/LF), AASHTO M270, Grade 50 Ship 2 pcs @ 6'-1 1/2" fabricated in accordance with Mark P1 on Sketch #6	3.69	\$1077.48
7	236	lb - 7/8" x 8" Galvanized Structural Steel Bar (23.8 #/LF), AASHTO M270, Grade 50 Ship 2 pcs @ 4'-11 1/2" fabricated in accordance with Mark P2 on Sketch #6	3.69	\$ 870.84
8	2500	lb - C12x25, Galvanized Structural Steel Channel, AASHTO M270, Grade 50 Ship 5 pcs @ 20'-0"	1.59	\$ 3975.00
9	870	lb - 1" x 8" Galvanized Structural Steel Bar (27.2 #/LF), AASHTO M270, Grade 50 Ship 2 pcs @ 16'-0"	2.71	\$ 2357.70

10	2000	lb - C10x20, Galvanized Structural Steel Channel, AASHTO M270, Grade 50 Ship 5 pcs @ 20'-0"	1.59	\$ 3180.00
11	576	lb - L 4"x4"x 1/2" (12.8#/LF) Galvanized Structural Steel Angle, AASHTO M270, Grade 50 Ship 54 pcs @ 0'-10" fabricated in accordance with Sketch #7	2.68	\$ 1543.68
12	3060	lb - 3/4" x 10" Galvanized Structural Steel Bar (25.5 #/LF), AASHTO M270, Grade 50 Ship 6 pcs @ 20'-0"	2.25	\$ 6885.00
13	3600	lb - HP 8x36, Galvanized HP- Shaped Structural Steel, AASHTO M270, Grade 50 Ship 5 pcs @ 20'-0"	1.39	\$ 5004.00
			Total	\$ 59,824.71

Items for Project S347-39-2.09, Pleasant Run #2 Bridge & S336-21/6-0.03, Dead Owl Bridge

43,443



## State of West Virginia VENDOR PREFERENCE CERTIFICATE

Certification and application\* is hereby made for Preference in accordance with *West Virginia Code*, §5A-3-37. (Does not apply to construction contracts). *West Virginia Code*, §5A-3-37, provides an opportunity for qualifying vendors to request (at the time of bid) preference for their residency status. Such preference is an evaluation method only and will be applied only to the cost bid in accordance with the *West Virginia Code*. This certificate for application is to be used to request such preference. The Purchasing Division will make the determination of the Resident Vendor Preference, if applicable.

1. Application is made for 2.5% resident vendor preference for the reason checked:  
 Bidder is an individual resident vendor and has resided continuously in West Virginia for four (4) years immediately preceding the date of this certification; or,  
 Bidder is a partnership, association or corporation resident vendor and has maintained its headquarters or principal place of business continuously in West Virginia for four (4) years immediately preceding the date of this certification; or 80% of the ownership interest of Bidder is held by another individual, partnership, association or corporation resident vendor who has maintained its headquarters or principal place of business continuously in West Virginia for four (4) years immediately preceding the date of this certification; or,  
 Bidder is a nonresident vendor which has an affiliate or subsidiary which employs a minimum of one hundred state residents and which has maintained its headquarters or principal place of business within West Virginia continuously for the four (4) years immediately preceding the date of this certification; or,
2. Application is made for 2.5% resident vendor preference for the reason checked:  
 Bidder is a resident vendor who certifies that, during the life of the contract, on average at least 75% of the employees working on the project being bid are residents of West Virginia who have resided in the state continuously for the two years immediately preceding submission of this bid; or,
3. Application is made for 2.5% resident vendor preference for the reason checked:  
 Bidder is a nonresident vendor employing a minimum of one hundred state residents or is a nonresident vendor with an affiliate or subsidiary which maintains its headquarters or principal place of business within West Virginia employing a minimum of one hundred state residents who certifies that, during the life of the contract, on average at least 75% of the employees or Bidder's affiliate's or subsidiary's employees are residents of West Virginia who have resided in the state continuously for the two years immediately preceding submission of this bid; or,
4. Application is made for 5% resident vendor preference for the reason checked:  
 Bidder meets either the requirement of both subdivisions (1) and (2) or subdivision (1) and (3) as stated above; or,
5. Application is made for 3.5% resident vendor preference who is a veteran for the reason checked:  
 Bidder is an individual resident vendor who is a veteran of the United States armed forces, the reserves or the National Guard and has resided in West Virginia continuously for the four years immediately preceding the date on which the bid is submitted; or,
6. Application is made for 3.5% resident vendor preference who is a veteran for the reason checked:  
 Bidder is a resident vendor who is a veteran of the United States armed forces, the reserves or the National Guard, if, for purposes of producing or distributing the commodities or completing the project which is the subject of the vendor's bid and continuously over the entire term of the project, on average at least seventy-five percent of the vendor's employees are residents of West Virginia who have resided in the state continuously for the two immediately preceding years.

Bidder understands if the Secretary of Revenue determines that a Bidder receiving preference has failed to continue to meet the requirements for such preference, the Secretary may order the Director of Purchasing to: (a) reject the bid; or (b) assess a penalty against such Bidder in an amount not to exceed 5% of the bid amount and that such penalty will be paid to the contracting agency or deducted from any unpaid balance on the contract or purchase order.

By submission of this certificate, Bidder agrees to disclose any reasonably requested information to the Purchasing Division and authorizes the Department of Revenue to disclose to the Director of Purchasing appropriate information verifying that Bidder has paid the required business taxes, provided that such information does not contain the amounts of taxes paid nor any other information deemed by the Tax Commissioner to be confidential.

Under penalty of law for false swearing (*West Virginia Code*, §61-5-3), Bidder hereby certifies that this certificate is true and accurate in all respects; and that if a contract is issued to Bidder and if anything contained within this certificate changes during the term of the contract, Bidder will notify the Purchasing Division in writing immediately.

Bidder: Charleston Steel

Signed: Dennis Nicholas

Date: 1/10/12

Title: Mgr Warehouse Sales

\*Check any combination of preference consideration(s) indicated above, which you are entitled to receive.

STATE OF WEST VIRGINIA  
Purchasing Division

**PURCHASING AFFIDAVIT**

West Virginia Code §5A-3-10a states: No contract or renewal of any contract may be awarded by the state or any of its political subdivisions to any vendor or prospective vendor when the vendor or prospective vendor or a related party to the vendor or prospective vendor is a debtor and the debt owned is an amount greater than one thousand dollars in the aggregate

**DEFINITIONS:**

"Debt" means any assessment, premium, penalty, fine, tax or other amount of money owed to the state or any of its political subdivisions because of a judgment, fine, permit violation, license assessment, defaulted workers' compensation premium, penalty or other assessment presently delinquent or due and required to be paid to the state or any of its political subdivisions, including any interest or additional penalties accrued thereon.

"Debtor" means any individual, corporation, partnership, association, Limited Liability Company or any other form or business association owing a debt to the state or any of its political subdivisions. "Political subdivision" means any county commission; municipality; county board of education; any instrumentality established by a county or municipality; any separate corporation or instrumentality established by one or more counties or municipalities, as permitted by law; or any public body charged by law with the performance of a government function or whose jurisdiction is coextensive with one or more counties or municipalities. "Related party" means a party, whether an individual, corporation, partnership, association, limited liability company or any other form or business association or other entity whatsoever, related to any vendor by blood, marriage, ownership or contract through which the party has a relationship of ownership or other interest with the vendor so that the party will actually or by effect receive or control a portion of the benefit, profit or other consideration from performance of a vendor contract with the party receiving an amount that meets or exceed five percent of the total contract amount.

**EXCEPTION:** The prohibition of this section does not apply where a vendor has contested any tax administered pursuant to chapter eleven of this code, workers' compensation premium, permit fee or environmental fee or assessment and the matter has not become final or where the vendor has entered into a payment plan or agreement and the vendor is not in default of any of the provisions of such plan or agreement.

Under penalty of law for false swearing (*West Virginia Code §61-5-3*), it is hereby certified that the vendor affirms and acknowledges the information in this affidavit and is in compliance with the requirements as stated.

**WITNESS THE FOLLOWING SIGNATURE**

Vendor's Name: CHARLESTON STEEL

Authorized Signature: Dennis Nicholas Date: 1/10/12

State of WEST VIRGINIA

County of KANAWHA, to-wit:

Taken, subscribed, and sworn to before me this 10 day of JANUARY, 2012.

My Commission expires 30 - JANUARY, 2021.

**AFFIX SEAL HERE**

**NOTARY PUBLIC** John E. Goetz IV

