



State of West Virginia
 Department of Administration
 Purchasing Division
 2019 Washington Street East
 Post Office Box 50130
 Charleston, WV 25305-0130

Request for Quotation

RFQ NUMBER
02120383

PAGE
1

ADDRESS CORRESPONDENCE TO ATTENTION OF
ALAN CUMMINGS
304-558-2402

VENDOR

*709042451 304-425-8955
EASTERN VAULT COMPANY INC
PO BOX 1134

PRINCETON WV 24740

SHIP TO

DIVISION OF HIGHWAYS
JOBSITE
SEE SPECIFICATIONS

DATE PRINTED 03/26/2012	TERMS OF SALE Net 30	SHIP VIA OUR TRUCKS	F.O.B. Jobsite	FREIGHT TERMS INCLUDED
-----------------------------------	--------------------------------	-------------------------------	--------------------------	----------------------------------

BID OPENING DATE: **04/11/2012** BID OPENING TIME **01:30PM**

LINE	QUANTITY	UOP	CAT. NO.	ITEM NUMBER	UNIT PRICE	AMOUNT
0001				210-16		\$87,766.50
<p>PRESTRESSED BOX BEAMS</p> <p>THE WEST VIRGINIA STATE PURCHASING DIVISION FOR THE AGENCY, THE WEST VIRGINIA DIVISION OF HIGHWAYS, IS SOLICITING BIDS TO PROVIDE THE AGENCY WITH PRESTRESSED CONCRETE BEAMS WITH ACCESSORIES PER THE ATTACHED SPECIFICATIONS.</p> <p>374 LINEAR FOOT - 36"X17" PRESTRESSED BOX BEAMS LENGTH: 41'-6" (OUT TO OUT) WIDTH: 27'-6" (OUT TO OUT, INCLUDE 3/4" BETWEEN BEAMS) SKEW: 20 DEGREE RFS DESIGN TO BE IN ACCORDANCE WITH SECTION 603 OF THE CURRENT WVDOH STANDARDS AND SPECIFICATIONS.</p> <p>BANKRUPTCY: IN THE EVENT THE VENDOR/CONTRACTOR FILES FOR BANKRUPTCY PROTECTION, THE STATE MAY DEEM THE CONTRACT NULL AND VOID, AND TERMINATE SUCH CONTRACT WITHOUT FURTHER ORDER.</p> <p>CANCELLATION: THE DIRECTOR OF PURCHASING RESERVES THE RIGHT TO CANCEL THIS CONTRACT IMMEDIATELY UPON WRITTEN NOTICE TO THE VENDOR IF THE COMMODITIES AND/OR SERVICES SUPPLIED ARE OF AN INFERIOR QUALITY OR DO NOT CONFORM TO THE SPECIFICATIONS OF THE BID AND CONTRACT HEREIN.</p> <p>EXHIBIT 10</p> <p style="text-align: right;">REQUISITION NO.:</p>						

RECEIVED
 2012 APR 11 AM 8:07
 WV PURCHASING DIVISION

SEE REVERSE SIDE FOR TERMS AND CONDITIONS			
SIGNATURE <i>B.P. Struble</i> BRIAN P. STRUBLE	TELEPHONE 304-425-8158	DATE 4-7-2012	ADDRESS CHANGES TO BE NOTED ABOVE
TITLE GENERAL MANAGER	FEIN 55-0520255		

WHEN RESPONDING TO RFQ, INSERT NAME AND ADDRESS IN SPACE ABOVE LABELED 'VENDOR'

GENERAL TERMS & CONDITIONS
REQUEST FOR QUOTATION (RFQ) AND REQUEST FOR PROPOSAL (RFP)

1. Awards will be made in the best interest of the State of West Virginia.
2. The State may accept or reject in part, or in whole, any bid.
3. Prior to any award, the apparent successful vendor must be properly registered with the Purchasing Division and have paid the required \$125 fee.
4. All services performed or goods delivered under State Purchase Order/Contracts are to be continued for the term of the Purchase Order/Contracts, contingent upon funds being appropriated by the Legislature or otherwise being made available. In the event funds are not appropriated or otherwise available for these services or goods this Purchase Order/Contract becomes void and of no effect after June 30.
5. Payment may only be made after the delivery and acceptance of goods or services.
6. Interest may be paid for late payment in accordance with the *West Virginia Code*.
7. Vendor preference will be granted upon written request in accordance with the *West Virginia Code*.
8. The State of West Virginia is exempt from federal and state taxes and will not pay or reimburse such taxes.
9. The Director of Purchasing may cancel any Purchase Order/Contract upon 30 days written notice to the seller.
10. The laws of the State of West Virginia and the *Legislative Rules* of the Purchasing Division shall govern the purchasing process.
11. Any reference to automatic renewal is hereby deleted. The Contract may be renewed only upon mutual written agreement of the parties.
12. **BANKRUPTCY:** In the event the vendor/contractor files for bankruptcy protection, the State may deem this contract null and void, and terminate such contract without further order.
13. **HIPAA BUSINESS ASSOCIATE ADDENDUM:** The West Virginia State Government HIPAA Business Associate Addendum (BAA), approved by the Attorney General, is available online at www.state.wv.us/admin/purchase/vrc/hipaa.html and is hereby made part of the agreement provided that the Agency meets the definition of a Cover Entity (45 CFR §160.103) and will be disclosing Protected Health Information (45 CFR §160.103) to the vendor.
14. **CONFIDENTIALITY:** The vendor agrees that he or she will not disclose to anyone, directly or indirectly, any such personally identifiable information or other confidential information gained from the agency, unless the individual who is the subject of the information consents to the disclosure in writing or the disclosure is made pursuant to the agency's policies, procedures, and rules. Vendor further agrees to comply with the Confidentiality Policies and Information Security Accountability Requirements, set forth in <http://www.state.wv.us/admin/purchase/privacy/noticeConfidentiality.pdf>.
15. **LICENSING:** Vendors must be licensed and in good standing in accordance with any and all state and local laws and requirements by any state or local agency of West Virginia, including, but not limited to, the West Virginia Secretary of State's Office, the West Virginia Tax Department, and the West Virginia Insurance Commission. The vendor must provide all necessary releases to obtain information to enable the director or spending unit to verify that the vendor is licensed and in good standing with the above entities.
16. **ANTITRUST:** In submitting a bid to any agency for the State of West Virginia, the bidder offers and agrees that if the bid is accepted the bidder will convey, sell, assign or transfer to the State of West Virginia all rights, title and interest in and to all causes of action it may now or hereafter acquire under the antitrust laws of the United States and the State of West Virginia for price fixing and/or unreasonable restraints of trade relating to the particular commodities or services purchased or acquired by the State of West Virginia. Such assignment shall be made and become effective at the time the purchasing agency tenders the initial payment to the bidder.

I certify that this bid is made without prior understanding, agreement, or connection with any corporation, firm, limited liability company, partnership, or person or entity submitting a bid for the same material, supplies, equipment or services and is in all respects fair and without collusion or fraud. I further certify that I am authorized to sign the certification on behalf of the bidder or this bid.

INSTRUCTIONS TO BIDDERS

1. Use the quotation forms provided by the Purchasing Division. Complete all sections of the quotation form.
2. Items offered must be in compliance with the specifications. Any deviation from the specifications must be clearly indicated by the bidder. Alternates offered by the bidder as **EQUAL** to the specifications must be clearly defined. A bidder offering an alternate should attach complete specifications and literature to the bid. The Purchasing Division may waive minor deviations to specifications.
3. Unit prices shall prevail in case of discrepancy. All quotations are considered F.O.B. destination unless alternate shipping terms are clearly identified in the quotation.
4. All quotations must be delivered by the bidder to the office listed below prior to the date and time of the bid opening. Failure of the bidder to deliver the quotations on time will result in bid disqualifications: Department of Administration, Purchasing Division, 2019 Washington Street East, P.O. Box 50130, Charleston, WV 25305-0130
5. Communication during the solicitation, bid, evaluation or award periods, except through the Purchasing Division, is strictly prohibited (W.Va. C.S.R. §148-1-6.6).



State of West Virginia
 Department of Administration
 Purchasing Division
 2019 Washington Street East
 Post Office Box 50130
 Charleston, WV 25305-0130

Request for Quotation

RFQ NUMBER
02120383

PAGE
2

ADDRESS CORRESPONDENCE TO ATTENTION OF
ALAN CUMMINGS 304-558-2402

VENDOR

*709042451 304-425-8955
 EASTERN VAULT COMPANY INC
 PO BOX 1134

 PRINCETON WV 24740

SHIP TO

DIVISION OF HIGHWAYS
 JOBSITE
 SEE SPECIFICATIONS

DATE PRINTED	TERMS OF SALE	SHIP VIA	F.O.B.	FREIGHT TERMS
03/26/2012				

BID OPENING DATE: **04/11/2012** BID OPENING TIME **01:30PM**

LINE	QUANTITY	UOP	CAT. NO.	ITEM NUMBER	UNIT PRICE	AMOUNT
<p>ADDENDUM ACKNOWLEDGEMENT</p> <p>I HEREBY ACKNOWLEDGE RECEIPT OF THE FOLLOWING CHECKED ADDENDUM(S) AND HAVE MADE THE NECESSARY REVISIONS TO MY PROPOSAL, PLANS AND/OR SPECIFICATION, ETC.</p> <p>ADDENDUM NO.'S:</p> <p>NO. 1</p> <p>NO. 2</p> <p>NO. 3</p> <p>NO. 4</p> <p>NO. 5</p> <p>I UNDERSTAND THAT FAILURE TO CONFIRM THE RECEIPT OF THE ADDENDUM(S) MAY BE CAUSE FOR REJECTION OF BIDS.</p> <p>VENDOR MUST CLEARLY UNDERSTAND THAT ANY VERBAL REPRESENTATION MADE OR ASSUMED TO BE MADE DURING ANY ORAL DISCUSSION HELD BETWEEN VENDOR'S REPRESENTATIVES AND ANY STATE PERSONNEL IS NOT BINDING. ONLY THE INFORMATION ISSUED IN WRITING AND ADDED TO THE SPECIFICATIONS BY AN OFFICIAL ADDENDUM IS BINDING.</p> <p style="text-align: right;">  SIGNATURE .. EASTERN VAULT Co., Inc. COMPANY 4-7-2012 </p>						

SEE REVERSE SIDE FOR TERMS AND CONDITIONS			
SIGNATURE	TELEPHONE	DATE	
TITLE	FEIN	ADDRESS CHANGES TO BE NOTED ABOVE	

WHEN RESPONDING TO RFQ, INSERT NAME AND ADDRESS IN SPACE ABOVE LABELED 'VENDOR'



State of West Virginia
 Department of Administration
 Purchasing Division
 2019 Washington Street East
 Post Office Box 50130
 Charleston, WV 25305-0130

Request for Quotation

RFQ NUMBER
02120383

PAGE
3

ADDRESS CORRESPONDENCE TO ATTENTION OF
ALAN CUMMINGS 304-558-2402

VENDOR	*709042451 304-425-8955
	EASTERN VAULT COMPANY INC
	PO BOX 1134
	PRINCETON WV 24740

SHIP TO	DIVISION OF HIGHWAYS
	JOBSITE
	SEE SPECIFICATIONS

DATE PRINTED	TERMS OF SALE	SHIP VIA	F.O.B.	FREIGHT TERMS
03/26/2012				

BID OPENING DATE: 04/11/2012 BID OPENING TIME 01:30PM

LINE	QUANTITY	UOP	CAT NO	ITEM NUMBER	UNIT PRICE	AMOUNT
DATE						
<p>NOTE: THIS ADDENDUM ACKNOWLEDGEMENT SHOULD BE SUBMITTED WITH THE BID.</p> <p>REV. 09/21/2009</p> <p>PREFERENCE FOR USE OF DOMESTIC STEEL PRODUCTS</p> <p>1. EXCEPT WHEN AUTHORIZED BY THE DIRECTOR OF THE PURCHASING DIVISION PURSUANT TO SUBSECTION 2 BELOW NO CONTRACTOR MAY USE OR SUPPLY STEEL PRODUCTS FOR A STATE CONTRACT PROJECT OTHER THAN THOSE STEEL PRODUCTS MADE IN THE UNITED STATES. AS USED USED IN THIS CONTRACT,</p> <p>A. "STATE CONTRACT PROJECT" MEANS ANY ERECTION OR CONSTRUCTION OF, OR ANY ADDITION TO, ALTERATION OF OR OTHER IMPROVEMENT TO ANY BUILDING OR STRUCTURE, INCLUDING, BUT NOT LIMITED TO, ROADS OR HIGHWAYS, OR THE INSTALLATION OF ANY HEATING OR COOLING OR VENTILATING PLANTS OR OTHER EQUIPMENT, OR THE SUPPLY OF AND MATERIALS FOR SUCH PROJECTS, PURSUANT TO A CONTRACT WITH THE STATE OF WEST VIRGINIA FOR WHICH BIDS WERE SOLICITED ON OR AFTER JUNE 6, 2001.</p> <p>B. "STEEL PRODUCTS" MEANS PRODUCTS ROLLED, FORMED, SHAPED, DRAWN, EXTRUDED, FORGED, CAST, FABRICATED OR OTHERWISE SIMILARLY PROCESSED, OR PROCESSED BY A COMBINATION OF TWO OR MORE OF SUCH OPERATIONS, FROM STEEL MADE BY THE OPEN HEARTH, BASIC OXYGEN, ELECTRIC FURNACE, BESSEMER OR OTHER STEEL MAKING PROCESS.</p>						

SEE REVERSE SIDE FOR TERMS AND CONDITIONS						
SIGNATURE				TELEPHONE		DATE
TITLE		FEIN		ADDRESS CHANGES TO BE NOTED ABOVE		

WHEN RESPONDING TO RFQ, INSERT NAME AND ADDRESS IN SPACE ABOVE LABELED 'VENDOR'



State of West Virginia
 Department of Administration
 Purchasing Division
 2019 Washington Street East
 Post Office Box 50130
 Charleston, WV 25305-0130

Request for Quotation

RFO NUMBER
 02120383

PAGE
 4

ADDRESS CORRESPONDENCE TO ATTENTION OF:
 ALAN CUMMINGS
 304-558-2402

*709042451 304-425-8955
 EASTERN VAULT COMPANY INC
 PO BOX 1134
 PRINCETON WV 24740

DIVISION OF HIGHWAYS
 JOBSITE
 SEE SPECIFICATIONS

VENDOR

SHIP TO

DATE PRINTED	TERMS OF SALE	SHIP VIA	F.O.B.	FREIGHT TERMS
03/26/2012				

BID OPENING DATE: 04/11/2012 BID OPENING TIME 01:30PM

LINE	QUANTITY	UOP	CAT NO	ITEM NUMBER	UNIT PRICE	AMOUNT
C. "UNITED STATES" MEANS THE UNITED STATES OF AMERICA AND INCLUDES ALL TERRITORY, CONTINENTAL OR INSULAR, SUBJECT TO THE JURISDICTION OF THE UNITED STATES.						
2.	THE DIRECTOR OF THE PURCHASING DIVISION MAY, IN WRITING, AUTHORIZE THE USE OF FOREIGN STEEL PRODUCTS IF:					
	A. THE COST FOR EACH CONTRACT ITEM USED DOES NOT EXCEED ONE TENTH OF ONE PERCENT (.1%) OF THE TOTAL CONTRACT COST OR TWO THOUSAND FIVE HUNDRED DOLLARS (2,500.00), WHICHEVER IS GREATER. FOR THE PURPOSES OF THIS SECTION, THE COST IS THE VALUE OF THE STEEL PRODUCT AS DELIVERED TO THE PROJECT OR,					
	B. THE DIRECTOR OF THE PURCHASING DIVISION DETERMINES THAT SPECIFIED STEEL MATERIALS ARE NOT PRODUCED IN THE UNITED STATES IN SUFFICIENT QUANTITY OR OTHERWISE ARE NOT REASONABLY AVAILABLE TO MEET CONTRACT REQUIREMENTS.					
3.	A CONTRACTOR WHO USES STEEL PRODUCTS IN VIOLATION OF THIS SECTION MAY BE SUBJECT TO CIVIL PENALTIES PURSUANT TO WV CODE SECTION 5A-3-56.					
REV. 10/01/01						
NOTICE						
A SIGNED BID MUST BE SUBMITTED TO: DEPARTMENT OF ADMINISTRATION						

SEE REVERSE SIDE FOR TERMS AND CONDITIONS

SIGNATURE	TELEPHONE	DATE
TITLE	FEIN	ADDRESS CHANGES TO BE NOTED ABOVE

WHEN RESPONDING TO RFQ, INSERT NAME AND ADDRESS IN SPACE ABOVE LABELED 'VENDOR'



State of West Virginia
 Department of Administration
 Purchasing Division
 2019 Washington Street East
 Post Office Box 50130
 Charleston, WV 25305-0130

Request for Quotation

RFQ NUMBER
02120383

PAGE
5

ADDRESS CORRESPONDENCE TO ATTENTION OF
ALAN CUMMINGS 304-558-2402

VENDOR	*709042451 304-425-8955
	EASTERN VAULT COMPANY INC
	PO BOX 1134
	PRINCETON WV 24740

SHIP TO	DIVISION OF HIGHWAYS
	JOBSITE
	SEE SPECIFICATIONS

DATE PRINTED	TERMS OF SALE	SHIP VIA	F.O.B.	FREIGHT TERMS
03/26/2012				
BID OPENING DATE: 04/11/2012		BID OPENING TIME 01:30PM		

LINE	QUANTITY	UOP	CAT NO	ITEM NUMBER	UNIT PRICE	AMOUNT
PURCHASING DIVISION BUILDING 15 2019 WASHINGTON STREET, EAST CHARLESTON, WV 25305-0130						
THE BID SHOULD CONTAIN THIS INFORMATION ON THE FACE OF THE ENVELOPE OR THE BID MAY NOT BE CONSIDERED:						
SEALED BID						
BUYER: ALAN CUMMINGS - FILE 33						
RFQ. NO.: 02120383						
BID OPENING DATE: 4/11/2012						
BID OPENING TIME: 1:30 P.M.						
PLEASE PROVIDE A FAX NUMBER IN CASE IT IS NECESSARY TO CONTACT YOU REGARDING YOUR BID: ----- 1-304-425-1171 -----						
CONTACT PERSON (PLEASE PRINT CLEARLY): ----- BRIAN P. STRUBLE -----						
ANY INDIVIDUAL SIGNING THIS BID IS CERTIFYING THAT: (1) HE OR SHE IS AUTHORIZED BY THE BIDDER TO EXECUTE THE BID OR ANY DOCUMENTS RELATED THERE TO ON BEHALF OF						

SEE REVERSE SIDE FOR TERMS AND CONDITIONS						
SIGNATURE			TELEPHONE		DATE	
TITLE		FEIN	ADDRESS CHANGES TO BE NOTED ABOVE			

WHEN RESPONDING TO RFQ, INSERT NAME AND ADDRESS IN SPACE ABOVE LABELED 'VENDOR'



State of West Virginia
 Department of Administration
 Purchasing Division
 2019 Washington Street East
 Post Office Box 50130
 Charleston, WV 25305-0130

Request for Quotation

RFQ NUMBER
02120383

PAGE
5

ADDRESS CORRESPONDENCE TO ATTENTION OF
ALAN CUMMINGS 304-558-2402

VENDOR

*709042451 304-425-8955
 EASTERN VAULT COMPANY INC
 PO BOX 1134
 PRINCETON WV 24740

SHIP TO

DIVISION OF HIGHWAYS
 JOBSITE
 SEE SPECIFICATIONS

DATE PRINTED	TERMS OF SALE	SHIP VIA	F.O.B.	FREIGHT TERMS
03/26/2012				

BID OPENING DATE: **04/11/2012** BID OPENING TIME **01:30PM**

LINE	QUANTITY	UOP	CAT NO.	ITEM NUMBER	UNIT PRICE	AMOUNT
PURCHASING DIVISION BUILDING 15 2019 WASHINGTON STREET, EAST CHARLESTON, WV 25305-0130						
THE BID SHOULD CONTAIN THIS INFORMATION ON THE FACE OF THE ENVELOPE OR THE BID MAY NOT BE CONSIDERED: SEALED BID						
BUYER:				ALAN CUMMINGS - FILE 33		
RFQ. NO.:				02120383		
BID OPENING DATE:				4/11/2012		
BID OPENING TIME:				1:30 P.M.		
PLEASE PROVIDE A FAX NUMBER IN CASE IT IS NECESSARY TO CONTACT YOU REGARDING YOUR BID: ----- 1-304-425-1171 -----						
CONTACT PERSON (PLEASE PRINT CLEARLY): ----- BRIAN P. STRUBLE -----						
ANY INDIVIDUAL SIGNING THIS BID IS CERTIFYING THAT: (1) HE OR SHE IS AUTHORIZED BY THE BIDDER TO EXECUTE THE BID OR ANY DOCUMENTS RELATED THERE TO ON BEHALF OF						

SEE REVERSE SIDE FOR TERMS AND CONDITIONS

SIGNATURE	TELEPHONE	DATE
TITLE	FEIN	ADDRESS CHANGES TO BE NOTED ABOVE

WHEN RESPONDING TO RFQ, INSERT NAME AND ADDRESS IN SPACE ABOVE LABELED 'VENDOR'



State of West Virginia
 Department of Administration
 Purchasing Division
 2019 Washington Street East
 Post Office Box 50130
 Charleston, WV 25305-0130

Request for Quotation

RFQ NUMBER
02120383

PAGE
6

ADDRESS CORRESPONDENCE TO ATTENTION OF:
ALAN CUMMINGS 304-558-2402

VENDOR	*709042451 304-425-8955
	EASTERN VAULT COMPANY INC
	PO BOX 1134
	PRINCETON WV 24740

SHIP TO	DIVISION OF HIGHWAYS
	JOBSITE
	SEE SPECIFICATIONS

DATE PRINTED	TERMS OF SALE	SHIP VIA	F.O.B.	FREIGHT TERMS
03/26/2012				

BID OPENING DATE: 04/11/2012 BID OPENING TIME 01:30PM

LINE	QUANTITY	UOP	CAT NO	ITEM NUMBER	UNIT PRICE	AMOUNT
THE BIDDER, (2) THAT HE OR SHE IS AUTHORIZED TO BIND THE BIDDER IN A CONTRACTUAL RELATIONSHIP, AND (3) THAT THE BIDDER HAS PROPERLY REGISTERED WITH ANY STATE AGENCIES THAT MAY REQUIRE REGISTRATION.						
***** THIS IS THE END OF RFQ 02120383 ***** TOTAL:						<u>\$ 87,766.50</u>

SEE REVERSE SIDE FOR TERMS AND CONDITIONS

SIGNATURE		TELEPHONE	DATE
TITLE	FEIN	ADDRESS CHANGES TO BE NOTED ABOVE	

WHEN RESPONDING TO RFQ, INSERT NAME AND ADDRESS IN SPACE ABOVE LABELED 'VENDOR'

Specifications One Time Purchase

Purpose: To provide the West Virginia Division of Highways with prestressed concrete beams (designed for a deck) with accessories to be used on Project # S323-14-2.67, Slab Fork Bridge.

1.0 DEFINITIONS

- A. The "Agency" shall be defined as the West Virginia Division of Highways
- B. The "Vendor" shall be defined as the successful bidder.
- C. The "Purchase Order" shall be defined as the binding agreement that is entered into between the State of West Virginia and the Vendor to provide the services as herein specified.
- D. "Mandatory Requirements: The terms "must", "will", "shall", "minimum", "maximum", or "is/are required" identify a mandatory item or factor. Decisions regarding compliance with any mandatory requirements shall be at the sole discretion of the State.

2.0 SCOPE OF WORK

The successful Vendor shall provide 36" wide x 17" deep prestressed concrete beams (designed for a deck) with accessories.

2.1 Technical Requirements:

All prestressed concrete beams (designed for a deck) with accessories provided shall be in accordance with West Virginia Division of Highways Standard Specifications Roads and Bridges, adopted 2010 and the current Supplemental Specifications and the attached control prints.

www.transportation.wv.gov/highways/engineering/Pages/publications.aspx

2.2.1 All shipments are to be FOB Destination

2.2.2 The Vendor shall be responsible for all costs associated with delivery to the job site.

2.2 Delivery

2.2.1 Deliveries shall be made to job site on CR 14 (Map Attached)

2.2.2 . Vendor shall coordinate delivery with the District Bridge Engineer @ 304-528-5655.

2.3 Delivery is an integral part of this purchase order and failure to comply will be cause to initiate a WV-82, vendor Performance Form. This form will officially notify the West Virginia Division of Purchasing and the Vendor of unsatisfactory performance in the execution of this purchase order and the requirements herein.

3.0 INVOICING

3.1 Payment

3.1.1 The Vendor must send an invoice to:
West Virginia Division of Highways, District Two
801 Madison Avenue
Huntington, WV 25704

3.2 Partial Payment of Approved Beams

3.2.1 Upon completion of manufacture and approval by the Division of Highways of all beams specified on the purchase order, the vendor may invoice and the Division will pay for the cost of manufacturing the Beams, not to exceed 65% of the total cost of the delivered Beams. The remaining, 35% or more, may be invoiced when all the Beams are delivered. Partial payment for Beams shall be subject of the following conditions:

- a. The vendor must request partial payment and furnish an official invoice for the manufactured and approved Beams.
- b. The partial payment invoice shall be accompanied by a surety bond equal to the invoiced amount guaranteeing delivery of all items specified on the purchase order.

- c. The vendor shall furnish a statement of approved Beams' condition and exact storage location.
- d. The vendor shall furnish a legal right-of-entry onto the storage site to Division of Highways' employees and/or agents for the purpose of inspecting, sampling, testing, and removing any or all Beams.
- e. The vendor shall certify that the stored Beams are suitably marked and identified as property of the Division of highways and will not be used for any purpose not designated by the Division.

4.0 AWARD

Purchase order will be awarded complete and not split.

Cost Sheet

RFQ#

Item Number	Quantity	Unit of Measurement	Description	Unit Price	Extended Amount
1	290.5	Lineal feet	Interior Beam 17" prestressed concrete box beam (3ft. Wide) 7 beams x 41.5	143.00	41,541.50
2	83	Lineal feet	exterior Beam 17" prestressed concrete box beam (3ft. Wide) 2 beams x 41.5	170.00	14,110.00
3	36	Each	Elastomeric Bearing Pads	150.00	5400.00
4	18	Each	1" Diameter x 2'-0" Anchor bolt or No. 8 deformed rebar	10.00	180.00
5	18	Each	Guardrail Attachment Assembly for box beam w/ studs, nut and washers	295.00	5,310.00
6	5	Each	1" Diameter Post- Tensioning Bar w/nuts	400.00	2,000.00
7	18	Each	Bearing Plates	75.00	1,350.00
8	1	lump sum	Thick sponge rubber Preformed joint filler	3000.00	3,000.00
9	85	Lineal feet	Guardrail	175.00	14,875.00
				Total	87,766.50

Items for Project S323-14-2.67, Slab Fork

SLAB FORK CONCRETE BEAM BRIDGE

S323-14-2.67 00

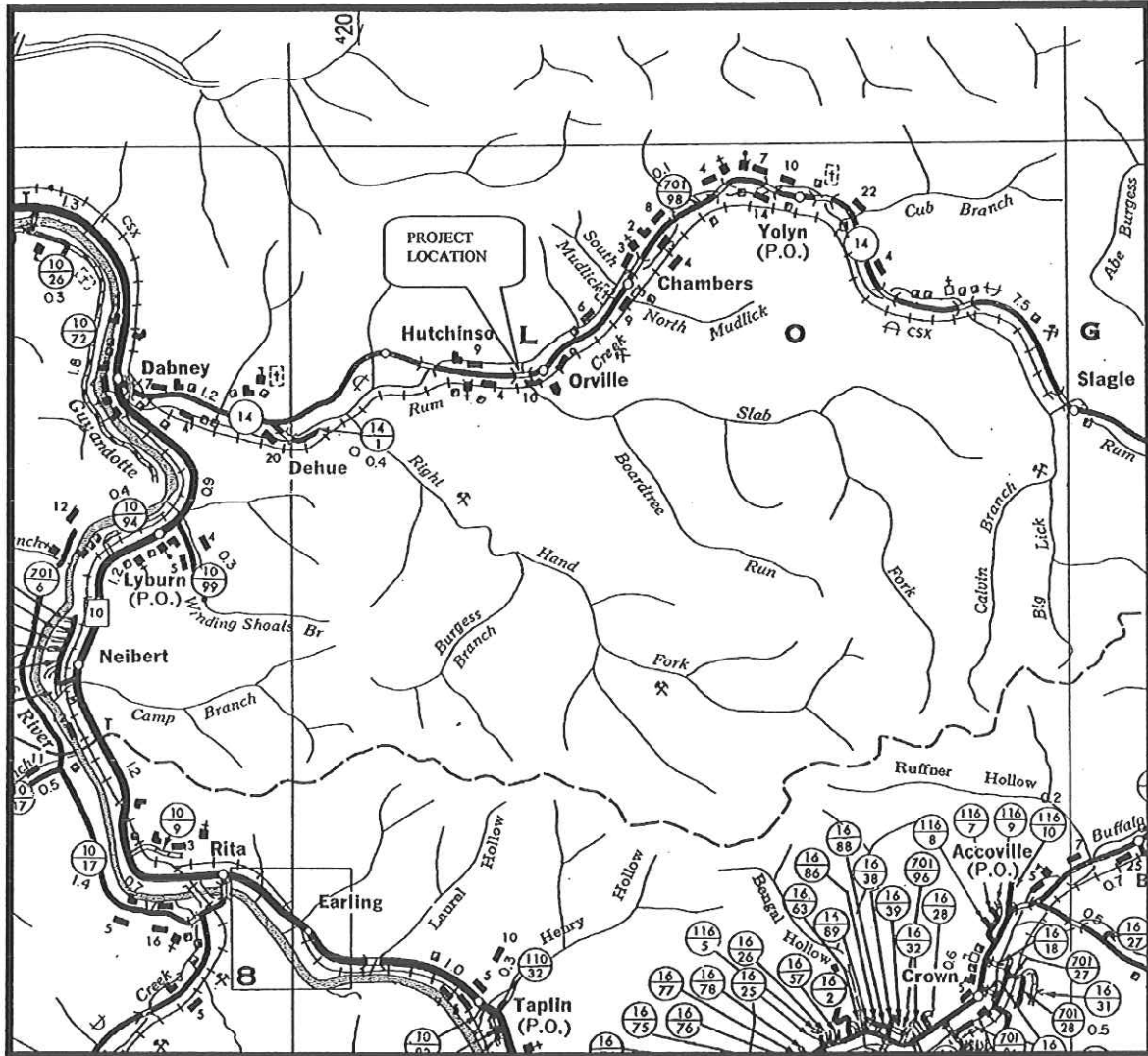

PROJECT NUMBERS		DISTRICT	COUNTY	SHEET NO.	TOTAL
STATE	FEDERAL				
S323-14-2.67	N.A.	2	LOGAN		

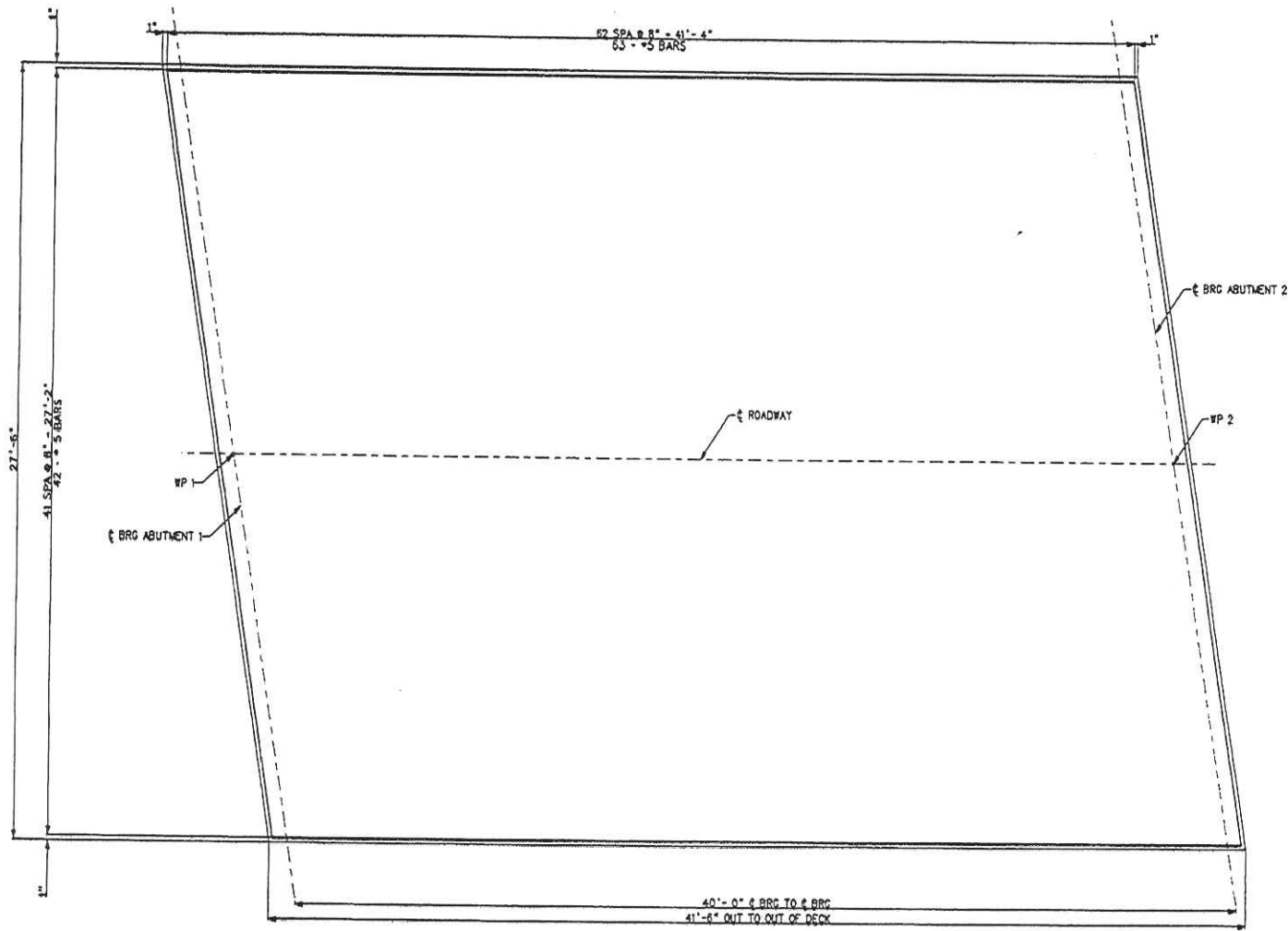

PLAN

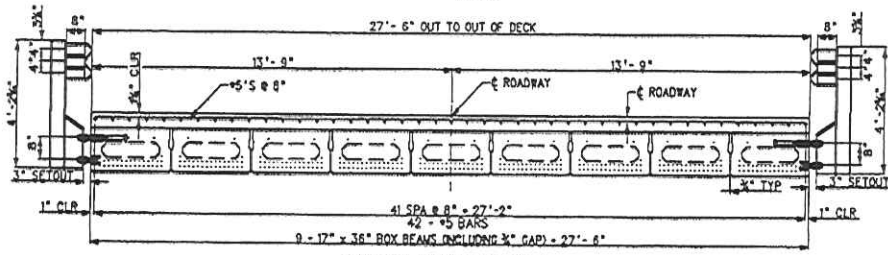

TYPICAL BRIDGE SECTION

NO.	REVISION	DATE	BY

WEST VIRGINIA DEPARTMENT OF TRANSPORTATION
DIVISION OF HIGHWAYS
ENGINEERING DIVISION

DESIGNED	DATE	CHECKED	DATE
TWB	08/10	SMR	09/10
DRAWN	DATE	REVIEWED	DATE
TWB	09/10	SMR	09/10

SLAB FORK BRIDGE
LOGAN COUNTY

DECK LAYOUT

SHEET	OF	DESIGN NUMBER
1	1	

PROJECT NUMBERS		DISTRICT	COUNTY	SHEET NO.	TOTAL
STATE	FEDERAL				
S323-14-2.67	N.A.	2	LOGAN		

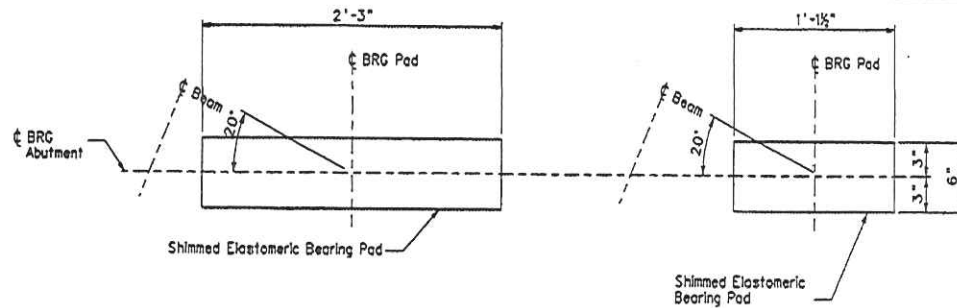

PLAN

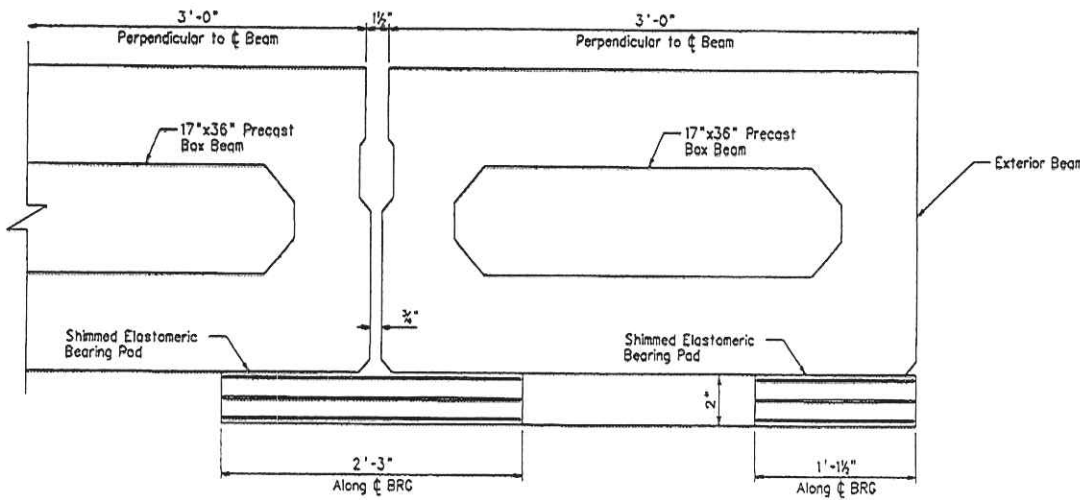

ELEVATION

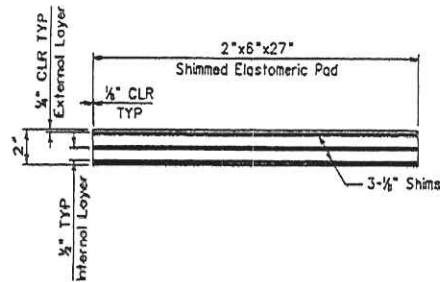

SHIMMED ELASTOMERIC BEARING PAD

BEARINGS @ ABUTMENT 1 (8 Required)
BEARINGS @ ABUTMENT 2 (8 Required)

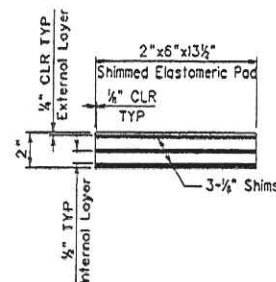

SHIMMED ELASTOMERIC BEARING PAD @ ABUTMENT 1 & 2

BEARINGS @ ABUTMENT 1 (2 Required)
BEARINGS @ ABUTMENT 2 (2 Required)

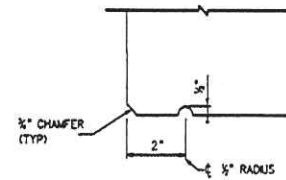

DRP GROOVE DETAIL EXTERIOR BEAMS

FOAM BLOCKOUT RECD. AFTER ERECTION FILL VOID WITH GROUT MEETING THE REQUIREMENTS OF SUB-SECT. 715.3

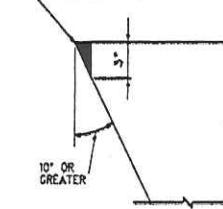

SKEW BLOCKOUT DETAIL

Bearing Notes:

Elastomeric Bearing Pads are designed in accordance with Design Method B contained in Section 14 of the AASHTO LRFD Bridge Design Specifications.

The provisions for fabrication, installation, testing, and shipping of Elastomeric Bearings, specified in Section 18, "Bearings," of the AASHTO LRFD Bridge Construction Specifications, shall apply. The laminate material shall be AASHTO M83 or equivalent in the thickness detailed.

The cost of Elastomeric Bearing Pads shall be included in the price bid for Item 603016-007, 17x36 Precast Concrete Box Beam.

The Bearings shall be low temperature Grade 3 and have a Shear Modulus between 130 and 175 PSI, Durometer hardness of 60. Reinforcing shims shall have a minimum yield strength of 36 ksi.

Bearing surfaces shall be finished according to Section 615.4.6. Finish in the direction of rotation.

Bearings shall be positioned so that they are centered at 68°F.

Install beams and bearings to provide full contact with bearing surfaces. If full contact is not achieved after the deck is in place, field adjustments or modifications shall be made by the Contractor to provide full contact at no additional cost to the WVDOT. Adjustments/modifications are subject to the approval of the Engineer.

This sheet shall be used in conjunction with Standard Sheets BR-B17A & B, BR-B100, BR-B101, BR-B102A & B, BR-B103, BR-B104, BR-B105A & B, and BR-B106 as appropriate.

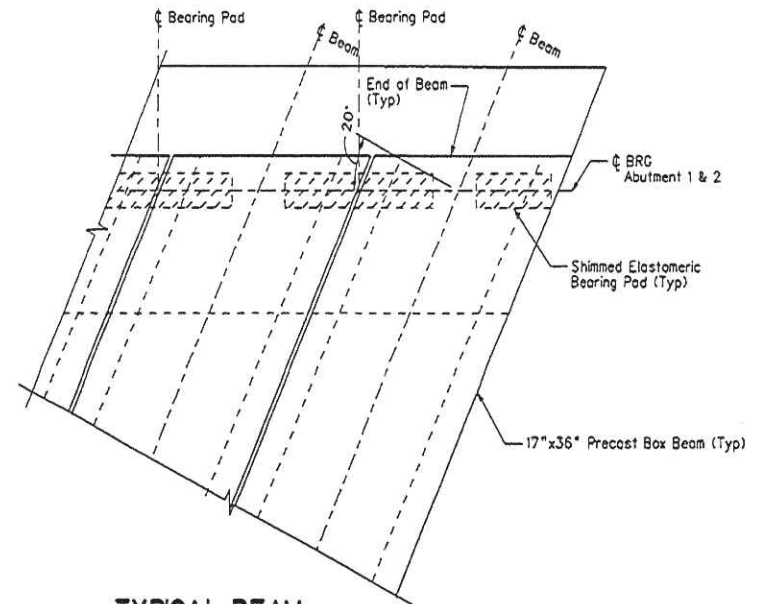

TYPICAL BEAM BEARING DETAIL

NO.	REVISION	DATE	BY

WEST VIRGINIA DEPARTMENT OF TRANSPORTATION
DIVISION OF HIGHWAYS
ENGINEERING DIVISION

DESIGNED	DATE	CHECKED	DATE
TWS	09/10	SMR	09/10
DRAWN	DATE	REVIEWED	DATE
TWS	09/10	SMR	09/10

SLAB FORK BRIDGE
LOGAN COUNTY

BEARING PAD
DETAILS

SHEET	OF	DESIGN NUMBER
1	(1)	

14-SEP-2010 11:49 AM - Project330b_ForkSlab.dwg/VP/Drawings/VP/Bearing_Pad/330b_ForkSlab.dwg

PROJECT NUMBERS				SHEET NO.	TOTAL
STATE	FEDERAL	DISTRICT	COUNTY		
\$325-14-2-67	N.A.	2	LOGAN		

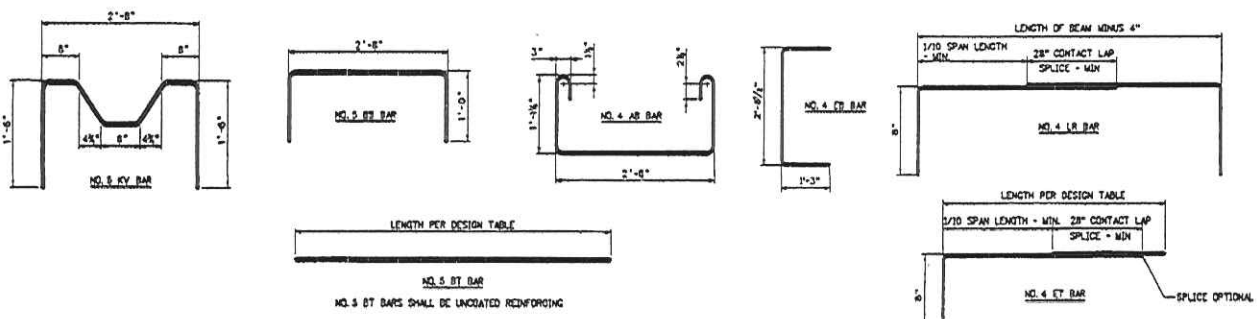
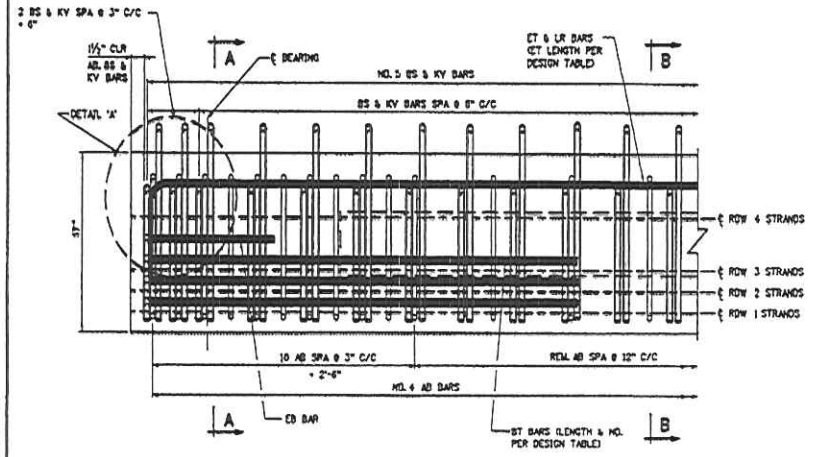
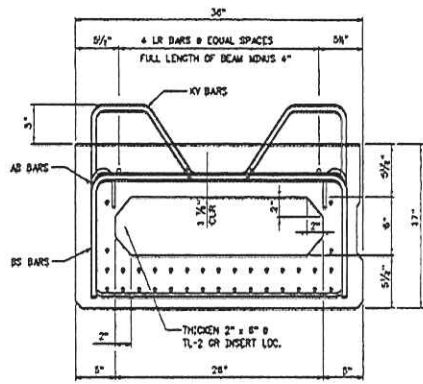
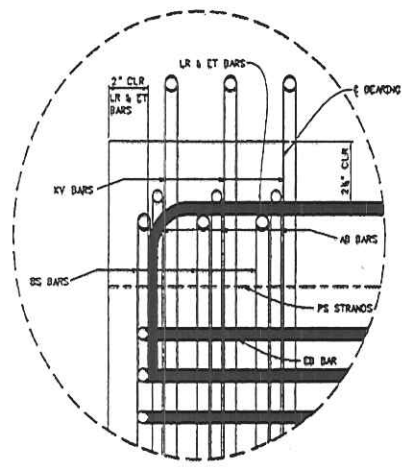
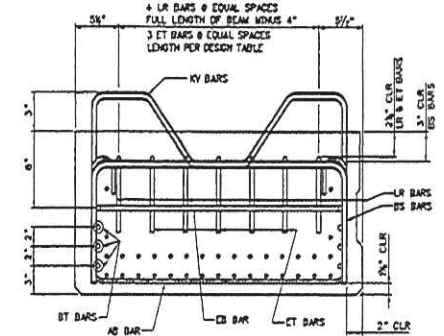
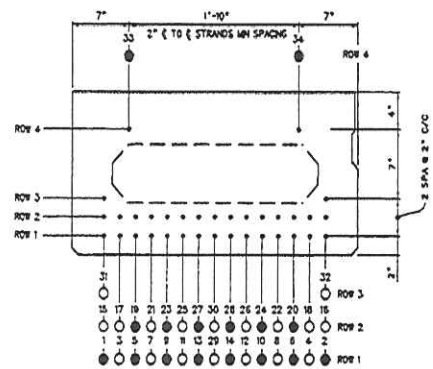
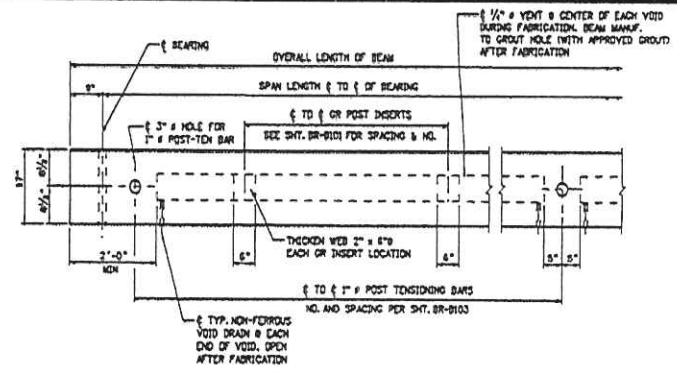

NOTES:

- REFER TO SHEET BR-B162A FOR SHEAR KEY DETAILS.
- DESIGNER SHALL USE THE FOLLOWING KEY TO INDICATE STRAND AND DEBONDING PATTERN ON "BEAM PRESTRESSING VIEW", THIS SHEET.
 - ACTIVE STRAND
 - ▽ DEBOND STRAND. LENGTH FROM D/O OF BEAM
 - △ DEBOND STRAND. LENGTH FROM D/O OF BEAM
 - DEBOND STRAND. LENGTH FROM D/O OF BEAM
- THIS SHEET SHALL BE USED IN CONJUNCTION WITH STANDARD SHEETS BR-B161, BR-B100, BR-B101, BR-B102A & B, BR-B103, BR-B104, BR-B105A & B AND BR-B106 AS APPLICABLE.

WEST VIRGINIA DEPARTMENT OF TRANSPORTATION DIVISION OF HIGHWAYS ENGINEERING DIVISION				DESIGNED		DATE		CHECKED		DATE		SHEET			
				TMB		08/10		SMR		09/10		17			
				DRAWN		09/10		REVIEWED		09/10		OF			
				TMB		09/10		SMR		09/10		DESIGN NUMBER			
								SLAB FORK BRIDGE LOGAN COUNTY				SHEET BR-B17A 17" PRESTRESSED CONCRETE BOX BEAM DESIGN & ASSEMBLY DETAILS			
NO. REVISION DATE BY:				WEST VIRGINIA DEPARTMENT OF TRANSPORTATION DIVISION OF HIGHWAYS ENGINEERING DIVISION				DESIGNED DATE CHECKED DATE				SHEET OF DESIGN NUMBER			

6/11/2010 11:43 AM
 S:\BRIDGE\2010\11-17-10\17" PRESTRESSED CONCRETE BOX BEAM DESIGN & ASSEMBLY DETAILS\BR-B17A.dwg
 17" PRESTRESSED CONCRETE BOX BEAM DESIGN & ASSEMBLY DETAILS

PROJECT NUMBERS		DISTRICT	COUNTY	SHEET NO.	TOTAL
STATE	FEDERAL				
3323-14-2.07	N.A.	2	LOGAN	.	

DESIGN TABLE

SPAN LENGTH ϕ TO ϕ BEARING		40'-0"
OVERALL LENGTH OF BEAM		41'-6"
NO. OF 270 KSI, $\frac{3}{8}$ " # LOW-RELAXATION STRANDS, AREA/STRAND = 0.153 SQ. IN.		16
STRAND POSITION NUMBER	ROW 1	1,2,5,6, 9,10,13,14
	ROW 2	19,20,23, 24,27,28
	ROW 3	0
	ROW 4	33,34
PRESTRESSING FORCE IMMEDIATELY AFTER STRAND RELEASE, P_{pi} , (KIPS/BEAM)		517
EFFECTIVE PRESTRESSING FORCE AFTER ALL LOSSES, P_{pe} , (KIPS/BEAM)		473
REQUIRED FACTORED MOMENT ϕ STRENGTH I, M_u (FT-KIPS/BEAM)		535
FACTORED FLEXURAL RESISTANCE, M_r (FT-KIPS/BEAM)		919
TOTAL NO. DEBONDED STRANDS		0
DEBONDED STRAND POSITION NUMBER & SHIELDING LENGTH FROM EACH END	ROW 1	0
	ROW 2	0
NUMBER & LENGTH #4 ET TOP TENSION BARS ϕ EACH END		3 - #4 x 6'-0"
NUMBER & LENGTH #5 BT BOTTOM TENSION BARS ϕ EACH END		2 - #5 x 6'-0"
DESIGN CAMBER .. POSITIVE (UP) (INCHES)	ϕ RELEASE	0.582
	ϕ ERECTION	0.809
	ϕ FINAL	0.543
WEIGHT OF TYPICAL BEAM INCLUDING DIAPHRAGM (TONS)		10.6

NOTES

SUPER IMPOSED DEAD LOADS INCLUDE TYPE TL-2 GUARDRAIL (50 PLF) AND A FWS OF 25 PSF.

PREDICTED DESIGN CAMBER VALUES LISTED IN THE TABLE ARE BASED ON EMPIRICAL FORMULAS AND AS SUCH ARE APPROXIMATE. FOR MEMBERS WITH SPAN-TO-DEPTH RATIOS AT OR EXCEEDING 25, THE TOLERANCE VALUES LISTED IN APPENDIX B OF PCI MANUAL FOR QUALITY CONTROL, MNL-116, MAY NOT APPLY.

MEASUREMENT OF CAMBER FOR COMPARISON TO PREDICTED DESIGN VALUES SHOULD BE COMPLETED WITHIN 72 HOURS OF RELEASE. ADDITIONALLY, CAMBER SHOULD BE EVALUATED UNDER CONDITIONS THAT MINIMIZE THE EFFECT OF TEMPERATURE VARIATION.

DESIGNER, FABRICATOR, AND ERECTOR SHALL BE AWARE THAT SKEWED END BEAMS MAY TWIST OR WARP, CAUSING UNEVEN BEAM SEATING AT THE BEARINGS. THE CONTRACTOR IS REQUIRED TO CORRECT AT THE TIME OF ERECTION BEFORE THE BEAMS ARE SECURED IN PLACE. METHOD OF CORRECTION SHALL PROVIDE AN EVEN, TOTAL BEARING AND A LEVEL TOP BEAM SURFACE. TOLERANCE, AFTER CORRECTION, SHALL BE (+/-) $\frac{1}{8}$ INCH. THE FABRICATOR SHALL NOTIFY THE CONTRACTOR AND DESIGNER IF CORRECTIONS ARE REQUIRED PRIOR TO SHIPMENT.

MIN. CONCRETE STRENGTH ϕ RELEASE	• 5500 PSI
MIN. CONCRETE STRENGTH ϕ 28 DAYS	• 8000 PSI
INITIAL PULL/STRAND	• 33.82 Kips
CROSS-SECTION AREA/STRAND	• 0.167 SQ. IN.

WEST VIRGINIA DEPARTMENT OF TRANSPORTATION DIVISION OF HIGHWAYS ENGINEERING DIVISION				DESIGNED TWB	DATE 08/10	CHECKED SMR	DATE 09/10	
				DRAWN TWB	DATE 09/10	REVIEWED SMR	DATE 09/10	
NO.	REVISION	DATE	BY					

SLAB FORK BRIDGE
LOGAN COUNTY

SHEET BR-817B

DESIGN TABLE FOR 17"
PRESTRESSED BOX BEAM

PROJECT NUMBER		DISTRICT	COUNTY	SHEET NO.	TOTAL
STATE	FEDERAL				
5323-14-2.67	N.A.	2	LOGAN		

GOVERNING SPECIFICATIONS

THE WEST VIRGINIA DEPARTMENT OF TRANSPORTATION DIVISION OF HIGHWAYS STANDARD SPECIFICATIONS FOR ROADS AND BRIDGES, ADOPTED 2000, AS AMENDED BY THE SUPPLEMENTAL SPECIFICATIONS ISSUED JANUARY 1, 2000. THE CONTRACT PLANS AND CONTRACT SPECIAL PROVISIONS ARE THE GOVERNING PROVISIONS APPLICABLE TO THIS PROJECT.

ALL BEAMS ARE DESIGNED IN ACCORDANCE WITH THE AASHTO LRFD BRIDGE DESIGN SPECIFICATIONS, 4TH EDITION, DATED 2007.

DESIGN NOTES

THE ADJACENT PRESTRESSED CONCRETE BRIDGE BEAMS FOR THIS PROJECT ARE DESIGNED TO MEET THE FOLLOWING CRITERIA:

- DESIGN LOADS:
 - HL-93 LIVE LOAD IN ACCORDANCE WITH THE AASHTO LRFD BRIDGE DESIGN SPECIFICATIONS.
 - FUTURE WEARING SURFACE OF 25 PSF OF ROADWAY.
 - TYPE TL-2 GUARDRAIL WEIGHING 50 PLF.
 - DIAPHRAGM DEAD LOAD, NUMBER REQUIRED BASED ON 15'-0" MAX. SPACING.
- TWO LANE BRIDGE WITH AN OVERALL WIDTH OF 27'-0" (INCL. 3/4" GAP BETWEEN ADJ. BEAMS), A CURB-TO-CURB WIDTH OF 27'-0", TRANSVERSE POST-TENSIONING, A 0° CONCRETE DECK, AND 20° SKEW.
- DESIGN STRENGTH AND UNIT STRESSES:

MINIMUM CONCRETE STRENGTH @ STRAND RELEASE	-----	6000	PSI
MINIMUM CONCRETE STRENGTH @ 28 DAYS	-----	6000	PSI
TEMPORARY STRESS LIMITS IN CONCRETE BEFORE LOSSES:			
COMPRESSION STRESS LIMIT @ STRAND RELEASE	-----	3600	PSI
TENSION STRESS LIMIT @ STRAND RELEASE	-----	-200	PSI
COMPRESSIVE STRESS LIMITS IN CONCRETE @ SERVICE I AFTER LOSSES:			
@ FINAL 1 (PS-DL+LL)	-----	4800	PSI
@ FINAL 2 (PS-DL)	-----	3600	PSI
@ FINAL 3 (60KPS-DL+LL)	-----	3200	PSI
TENSILE STRESS LIMIT IN CONCRETE @ SERVICE III AFTER LOSSES:			
@ FINAL 1 (PS-DL+LL)	-----	-270	PSI
TENSION STRESS LIMIT PRIOR TO TRANSFER	-----	202.5	KSI
TENSION STRESS LIMIT AFTER ALL LOSSES	-----	194.4	KSI
- DEBONDING OR SHIELDING OF STRANDS TO REDUCE TEMPORARY TENSILE STRESSES IS PERMITTED, HOWEVER DEBONDING IS LIMITED TO 40% PER ROW AND 25% TOTAL. IN NO INSTANCES SHALL OUTER STRANDS BE DEBONDED. DEBONDED STRANDS SHALL BE SEPARATED BY AT LEAST ONE FULLY BONDED STRAND AND SHALL BE SYMMETRICAL ABOUT THE C OF THE BEAM. SHIELDING OF STRANDS SHALL BE ACCOMPLISHED BY TAPING OR TIGHT FITTING PLASTIC TUBES TAPED AT EACH END.
- THE ELASTOMERIC BEARING PADS PROVIDED IN THE STANDARD DESIGNS ARE BASED ON ZERO GRADE AND ARE LIMITED TO A MAXIMUM OF 5% GRADE. IN INSTANCES OF GRADES EXCEEDING THIS LIMIT, PADS SHALL BE SPECIFICALLY DESIGNED. INDIVIDUAL PAD DESIGNS SHALL BE IN ACCORDANCE WITH SECTION 14, AASHTO LRFD. BEVELED SOLE PLATES ARE PERMITTED.
- MAXIMUM BEAM SKEW SHALL BE 30 DEGREES.
- WHEN ALTERNATE DESIGNS OR SITE SPECIFIC DESIGNS ARE PROVIDED, CRITERIA SET FORTH IN THESE STANDARDS SHALL APPLY.
- NEGATIVE DESIGN CAMBER AFTER ALL LOSSES IS NOT PERMITTED.
- EACH BEAM PROVIDED IN THESE STANDARD DESIGNS HAS BEEN LOAD RATED IN ACCORDANCE WITH SECTION 3.15 OF THE WEST VIRGINIA DIVISION OF HIGHWAYS BRIDGE DESIGN MANUAL 2004. ADDITIONALLY, LOAD RATING PROCEDURES ARE IN ACCORDANCE WITH THE AASHTO MANUAL FOR CONDITION EVALUATION AND LOAD AND RESISTANCE FACTOR RATING OF HIGHWAY BRIDGES, 2003.

LAP SPLICE TABLE				
BAR SIZE	NO. 3	NO. 4	NO. 5	NO. 6
SPLICE LEN.	22"	28"	34"	41"

MATERIALS & FABRICATION NOTES

THE PRESTRESSED CONCRETE BEAMS SHALL CONFORM TO ALL APPLICABLE PROVISIONS OF SECTION 603 OF THE STANDARD SPECIFICATIONS.

MILD REINFORCEMENT:

- ALL MILD REINFORCING STEEL SHALL BE GRADE 60, DEFORMED BILLET STEEL AND SHALL BE EPOXY COATED EXCEPT WHERE NOTED. ALL UNCOATED REINFORCING SHALL MEET THE REQUIREMENTS OF AASHTO M31. ALL EPOXY COATED REINFORCING SHALL MEET THE REQUIREMENTS OF AASHTO M284, EXCEPT WHERE AMENDED BY SECTION 709.1 OF THE STANDARD SPECIFICATIONS.
- ALL TENSION LAP SPLICES SHALL BE A CLASS B, CONTACT TYPE. MINIMUM LAP SPLICE LENGTHS SHALL BE AS GIVEN IN THE "LAP SPLICE TABLE", THIS SHEET. ADDITIONALLY, IF LAP SPLICING OF ET, LR, AND BT BARS IS USED, TERMINATION OF THE SPLICE SHALL BE NO CLOSER TO THE END OF THE BEAM THAN 1/10 OF THE SPAN LENGTH.
- MINIMUM BAR BENDING DIAMETER SHALL BE 6 BAR DIAMETERS, EXCEPT THAT NO. 4 AB BARS MAY HAVE A MINIMUM BEND DIAMETER OF 4 BAR DIAMETERS.
- MINIMUM CONCRETE COVER SHALL BE AS SPECIFIED IN SECTION 603.5 OF THE STANDARD SPECIFICATIONS, EXCEPT WHERE NOTED ON THE PLANS.

PRESTRESSING STRAND:

- ALL PRESTRESSING STEEL SHALL BE 1/2" #, GRADE 270, 7 WIRE UNCOATED, LOW-RELAXATION STRAND MEETING THE REQUIREMENTS OF AASHTO M203, SUPPLEMENT S1.
- ALL BEAMS DESIGNED IN THESE STANDARDS UTILIZE STRANDS WITH A NOMINAL AREA OF 0.157 SQ. IN. STRANDS WITH A NOMINAL AREA OF 0.153 SQ. IN. IS PERMITTED FOR INDIVIDUAL OR ALTERNATE DESIGNS. HOWEVER THE DESIGNER IS ENCOURAGED TO USE THE LARGER STRAND FOR UNIFORMITY REASONS. IN NO CASES WILL STRESS-RELIEVED STRAND BE PERMITTED.
- ALL STRANDS SHALL BE ENCLOSED INSIDE THE STIRRUP CAGE FOR THE FULL LENGTH OF THE BEAM.
- ALL EXPOSED PRESTRESSING STRAND AT EACH BEAM END SHALL BE SHOP COATED WITH A LIQUID COLD-APPLIED BITUMINOUS ELASTOMERIC WATERPROOFING MEMBRANE. MATERIAL SHALL MEET ASTM C836-84.

CONCRETE:

- ALL CONCRETE USED IN MANUFACTURING PRESTRESSED CONCRETE BEAMS SHALL MEET THE REQUIREMENTS OF SECTION 603.6 OF THE STANDARD SPECIFICATIONS. DESIGN STRENGTHS SHALL MEET OR EXCEED THE MINIMUM VALUES SET FORTH IN THESE PLANS.
- ALL CONCRETE USED IN PARAPETS AND CURBS SHALL BE CLASS K CONCRETE.

ELASTOMERIC BEARING PADS:

- ALL BEARING PADS SHALL MEET THE APPLICABLE REQUIREMENTS AS SET FORTH IN SECTION 10.2 OF THE AASHTO LRFD BRIDGE CONSTRUCTION SPECIFICATIONS, 1998 EDITION WITH CURRENT INTERIMS. ALL BEARINGS SHALL BE STEEL REINFORCED LAMINATED BEARINGS.
- THE ELASTOMER MATERIAL SHALL BE 60 DUROMETERS WITH A MINIMUM LOW TEMPERATURE GRADE OF F (32DM C).
- ALL STEEL REINFORCING SHALL MEET THE REQUIREMENTS OF AASHTO M270, GRADE 36.

GUARDRAIL, GUARDRAIL POSTS, TUBING & INSERTS:

- ALL W-BEAM GUARDRAIL AND ATTACHMENT HARDWARE SHALL BE IN ACCORDANCE WITH SECTION 712.4 OF THE STANDARD SPECIFICATIONS. GUARDRAIL POSTS, STRUCTURAL TUBING, POST ATTACHMENT INSERTS, AND HARDWARE SHALL MEET THE LISTED MATERIAL AND COATING SPECIFICATIONS:

ITEM	DESCRIPTION	MATERIAL SPEC.	COATING SPEC.
POST	W6x25	AASHTO M270, GR 36	AASHTO M111
PLATE	1/2" x 7"	AASHTO M270, GR 36	AASHTO M111
TUBING	TS B4x3/16	ASTM A500, GR B	AASHTO M111
CHANNEL	C7x9.8	AASHTO M270, GR 36	AASHTO M111
FERRULE	TYPE 2A	1/4" # x 2 1/2" MIN LEN.	ASTM A108 (3117 STEEL)
	ANCHOR	3/8" #	ASTM A510 (1018 STEEL)
STUDS	1/4" # x 8" LONG	ASTM A108 (1045 C.D. STEEL)	AASHTO M232
NUTS	1/4" #	AASHTO M291, CLASS C	AASHTO M232
COUPLERS	TYPE 1A	1/2" # x 5" LONG	ASTM A108 (3117 STEEL)
BOLTS	ANCHOR	1/2" # x 12" LONG	AASHTO M184 (TYPE 1, H40)
		3/8" # x ALL LEN.	AASHTO M184 (TYPE 1, H40)
NUTS	3/8" #	AASHTO M291, CLASS C	AASHTO M232
WASHERS	ALL	AASHTO M293	AASHTO M232

WELDING:

- TACK WELDING OF REINFORCEMENT IS NOT PERMITTED. REINFORCING CAGES AND LONGITUDINAL STEEL SHALL BE ADEQUATELY TIED WITH APPROVED MEANS TO PREVENT RACKING AND MISALIGNMENT.
- ALL WELDING OF FABRICATED ITEMS, AS SHOWN IN THESE PLANS SHALL BE IN ACCORDANCE WITH ALL APPLICABLE PROVISIONS OF AASHTO/AWS D15, 2002.

POST-TENSIONING BARS:

- POST - TENSIONING THREAD BARS SHALL BE ONE INCH DIAMETER, 150 KSI STEEL AND SHALL CONFORM TO AASHTO M275, TYPE II. STEEL THREAD BARS SHALL BE DESIGNED TO ALLOW THE USE OF HEAVY HEX NUTS AND COUPLERS THAT THREAD ONTO THE END OF THE DEFORMATIONS. HEAVY HEX NUTS AND COUPLERS SHALL BE OF A DESIGN AND MATERIAL RECOMMENDED BY THE BAR MANUFACTURER TO DEVELOP THE FULL TENSILE STRENGTH OF THE BAR. PROPERLY DOCUMENTED CERTIFIED MILL TEST REPORTS SHALL BE PROVIDED FOR EACH HEAT OF STEEL THREAD BARS.
- ALL POST-TENSIONING THREAD BARS, NUTS, BEARING PLATES, COUPLERS, AND ANCILLARY HARDWARE SHALL BE HOT-DIPPED GALVANIZED IN ACCORDANCE WITH AASHTO M11. THE GALVANIZING PLANT SHALL ADMINISTER ADEQUATE QUALITY CONTROL MEASURES TO SAFEGUARD AGAINST HYDROGEN EMBRITTLEMENT. QUALITY CONTROL MEASURES SHALL COMPLY WITH ASTM A143. CERTIFICATION FOR HOT-DIP GALVANIZING SHALL BE PROVIDED BY THE GALVANIZING PLANT.
- ALL POST-TENSIONING BEARING PLATES SHALL CONFORM TO AASHTO M270, GRADE 36.

SHAR KEY GROUT:

- SHAR KEY GROUT SHALL BE A GROUT THAT IS RECOMMENDED BY THE MANUFACTURER FOR A POURABLE GROUT APPLICATION AND THAT BASED ON THE MANUFACTURER'S TEST DATA WILL ATTAIN A MINIMUM OF 4500 PSI COMPRESSIVE STRENGTH IN 3 DAYS UNDER CONDITIONS REPRESENTATIVE OF THE CONDITIONS TO BE EXPERIENCED AT THE SITE. THE GROUT MUST BE LISTED ON THE APPROVED LIST OF GROUTS PUBLISHED BY THE WEST VIRGINIA DIVISION OF HIGHWAYS, MATERIALS CONTROL, SOIL AND TESTING DIVISION. THE CONTRACTOR SHALL PRE-TEST THE PROPOSED GROUT FOR COMPRESSIVE STRENGTH AT 3 AND 7 DAYS AND SUBMIT THE RESULTS TO THE BRIDGE PROJECT MANAGER FOR APPROVAL PRIOR TO INSTALLATION OF THE GROUT IN THE STRUCTURE. THE TESTS WILL BE BASED ON A POURABLE CONSISTENCY WITH THE SAME WATER/GROUT MIXTURE RATIO TO BE USED IN THE STRUCTURE.
- THE CONTRACTOR SHALL BE REQUIRED TO SUBMIT FOR EACH PROJECT, THE GROUT PRE-TEST RESULTS OBTAINED IN THE NOTE ABOVE. THE CONTRACTOR SHALL BE REQUIRED TO PERFORM A NEW PRE-TEST AND SUBMISSION FOR APPROVAL UNDER ANY OF THE FOLLOWING CONDITIONS:
 - A PERIOD OF 18 MONTHS HAS ELAPSED SINCE LAST PRE-APPROVAL TESTING.
 - GROUT MANUFACTURER HAS REVISED OR CHANGED THE GROUT SPECIFICATIONS.
 - THE CONTRACTOR ALTERS THE WATER/GROUT MIXTURE RATIO.
 - THE CONTRACTOR CHANGES GROUT MANUFACTURER.
- THE CONTRACTOR IS REQUIRED TO COMPLETE THE GROUT STRENGTH TABLE ON BR-B103.
- TEST PROCEDURE FOR DETERMINING THE COMPRESSIVE STRENGTH OF GROUT SHALL USE CUBE SPECIMENS IN ACCORDANCE WITH ASTM C109, AS MODIFIED BY ASTM C1107. GROUT TESTING IN ACCORDANCE WITH AASHTO T23 (STANDARD CYLINDER TEST) IS NOT ACCEPTABLE.

PROTECTIVE SURFACE TREATMENT:

- EACH PRESTRESSED CONCRETE BEAM SHALL BE TREATED BY THE MANUFACTURER AT THE FABRICATION PLANT WITH AN APPROVED CONCRETE SEALER (SILANE). AN APPROVED LIST OF CONCRETE SEALERS ARE ON FILE AT THE WEST VIRGINIA DIVISION OF HIGHWAYS, MATERIALS CONTROL, SOIL AND TESTING DIVISION. COVERAGE SHALL INCLUDE TOP AND BOTTOM OF INTERIOR BEAMS, AND TOP, BOTTOM AND EXTERIOR SIDE OF EXTERIOR BEAM. APPLICATION RATE SHALL BE PER TREATMENT MANUFACTURER'S RECOMMENDATION.
- AFTER COMPLETION OF THE SILANE TREATMENT BY FABRICATOR AND A MAXIMUM OF FIVE WORKING DAYS PRIOR TO SHIPMENT OF THE BEAMS, THE FABRICATOR SHALL BE RESPONSIBLE FOR ABRASIVE BLAST CLEANING TO CLEAN WHITE CONCRETE THE INTERIOR SIDES OF BEAMS FOR THE FULL LENGTH. CLEAN WHITE CONCRETE SHALL MEAN REMOVAL OF ALL DIRT, GREASE, OIL, AND LOOSE CONCRETE LANTANCE AND PROVIDE A ROUNDENED CONCRETE SURFACE. BLASTING MEDIUM SHALL BE APPROVED BY THE DIVISION OF HIGHWAYS.

SHOP DRAWINGS:

- THE FABRICATOR SHALL BE RESPONSIBLE FOR THE PREPARATION OF SHOP DRAWINGS IN ACCORDANCE WITH THE WEST VIRGINIA DIVISION OF HIGHWAYS DOCUMENTS, DD-102 AND THE STANDARD SPECIFICATIONS. ADDITIONAL INFORMATION IS PROVIDED IN SECTION 7 OF THE BRIDGE DESIGN MANUAL. SHOP DRAWINGS SHALL INCLUDE THE FABRICATOR'S DETENSIONING PLAN.

THIS SHEET SHALL BE USED IN CONJUNCTION WITH STANDARD SHEETS BR-B17A & B THRU BR-B42A & B, BR-B101, BR-B102A & B, BR-B103, BR-B104, BR-B105A & B AND BR-B106 AS APPLICABLE.

NO.	REVISION	DATE:	BY:	WEST VIRGINIA DEPARTMENT OF TRANSPORTATION DIVISION OF HIGHWAYS ENGINEERING DIVISION				DESIGNED TWB DATE 08/10	CHECKED SMR DATE 09/10	SLAB FORK BRIDGE LOGAN COUNTY	SHEET BR-B100 17" PRESTRESSED CONCRETE BOX BEAM DESIGN & ASSEMBLY NOTES	SHEET OF DESIGN NUMBER
				DRAWN TWB DATE 09/10		REVIEWED SMR DATE 09/10						

14-SEP-2010 11:16 S:\V\B103\16 - Hepco\5323-14-2.67\Fork\Slab\17" Post Drawing\BR-B100.CAD PLOT Job

PROJECT NUMBERS				SHEET NO.	TOTAL
STATE	FEDERAL	DISTRICT	COUNTY		
S323-14-2.87	N.A.	2	LOGAN	00	00

CONTROL DIMENSIONS		
DESCRIPTION	CODE	VALUE
OVERALL BEAM LENGTH	A	41'-6"
SPAN LENGTH, ϕ BEARINGS TO ϕ BEARING	B	40'-0"
SUPERSTRUCTURE WIDTH - OUT TO OUT	C	27'-6"
ROADWAY WIDTH - FACE GR/PARAPET TO FACE GR/PARAPET	D	27'-0"
NUMBER OF BEAMS REQUIRED	—	8
BEAM SIZE (WIDTH x DEPTH)	—	36" x 17"
SKEW ANGLE (NORMAL, DEG. R/S OR DEG. L/S)	E	10° R/S
PERPENDICULAR DISTANCE FROM FACE OF BEAM TO ϕ BEARING	F	8 3/8"
HLIC BEARING COURSE REQUIRED (YES/NO)	—	NO
THICKNESS OF WEARING COURSE @ ϕ OF DECK OR ROADWAY	G	N.A.
THICKNESS OF WEARING COURSE @ EDGE OF DECK OR PARAPET	H	N.A.
TL-2 BRIDGE GUARDRAIL SYSTEM REQUIRED (YES/NO)	—	YES
FABRICATOR TO SUPPLY TL-2 BRIDGE GUARDRAIL (YES/NO)	—	YES
FABRICATOR TO INSTALL BRIDGE GUARDRAIL PRIOR TO SHIPMENT (YES/NO) (IF NO, FABRICATOR TO SHIP LOOSE)	—	YES
NUMBER OF GUARDRAIL POST INSERTS REQUIRED PER SIDE	—	8
TYPE F PARAPET REQUIRED (YES/NO)	—	NO
DRAINS REQUIRED (YES/NO)	—	NO
NUMBER OF DRAINS REQUIRED PER SIDE	—	N.A.
10" CURB REQUIRED (YES/NO)	—	NO

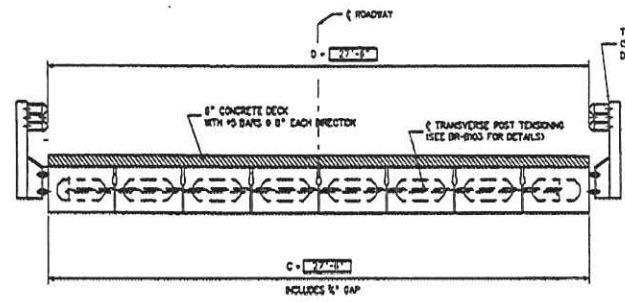

TYPICAL CROSS-SECTION WITH GUARDRAIL

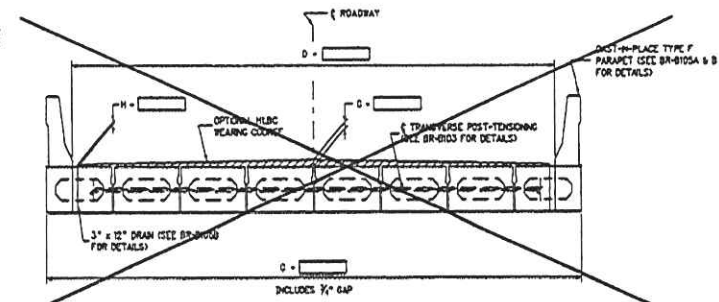

TYPICAL CROSS-SECTION WITH PARAPET OR CURB

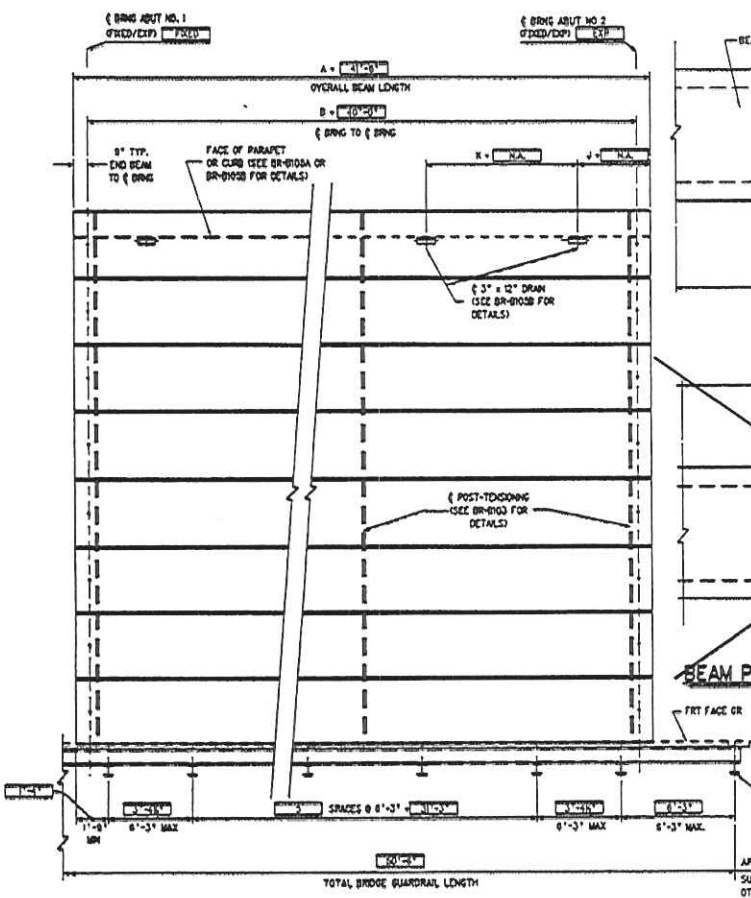

DECK PLAN VIEW

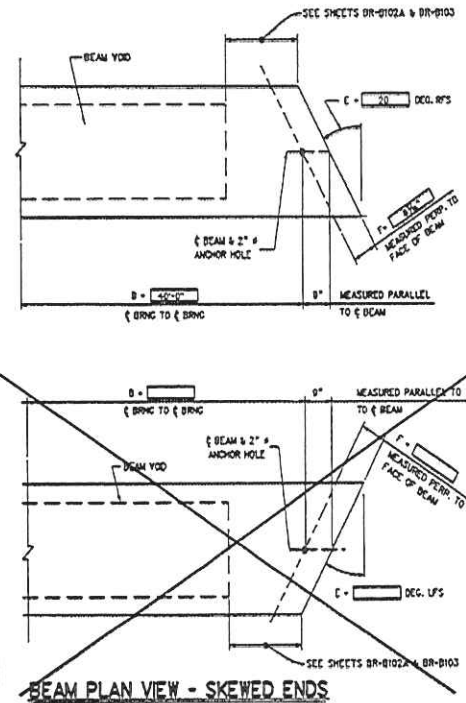

BEAM PLAN VIEW - SKEWED ENDS

ESTIMATE OF QUANTITIES

ITEM NO.	DESCRIPTION	UNITS	QUANTITY
803016-007	PRESTRESSED CONCRETE BOX BEAM	LF	373.5

- NOTES:
- WHEN BRIDGE GUARDRAIL IS TO BE SUPPLIED BY THE BEAM FABRICATOR, COST OF ALL BRIDGE GUARDRAIL ITEMS TO INCLUDE POSTS, RAIL ELEMENTS, ATTACHMENT HARDWARE, AND MISCELLANEOUS ITEMS NEEDED TO COMPLETELY INSTALL BRIDGE GUARDRAIL SHALL BE INCLUDED IN ITEM 803016 "PRESTRESSED CONCRETE BOX BEAM."
 - THIS SHEET SHALL BE USED IN CONJUNCTION WITH STANDARD SHEETS BR-B17A & B THRU BR-942A & B, BR-9100, BR-9102A & B, BR-9103, BR-9104, BR-9105A & B AND BR-9106.

NO.	REVISION	DATE:	BY:

WEST VIRGINIA DEPARTMENT OF TRANSPORTATION DIVISION OF HIGHWAYS ENGINEERING DIVISION			
DESIGNED	DATE	CHECKED	DATE
NRA	09/10	TWB	09/10
DRAWN	DATE	REVIEWED	DATE
NRA	09/10	TWB	09/10

SLAB FORK BRIDGE
LOGAN COUNTY

SHEET BR-B101
PRESTRESSED CONCRETE
BEAM DESIGN
& ASSEMBLY NOTES

SHEET	00 OF 00
DESIGN NUMBER	

14-SEP-2009 11:47 5:00PM - R:\proj\slab fork\beam\br-b101.dwg

PROJECT NUMBER		DISTRICT	COUNTY	SHEET NO.	TOTAL
STATE	FEDERAL				
S323-14-2.87	N.A.	2	LOGAN	00	00

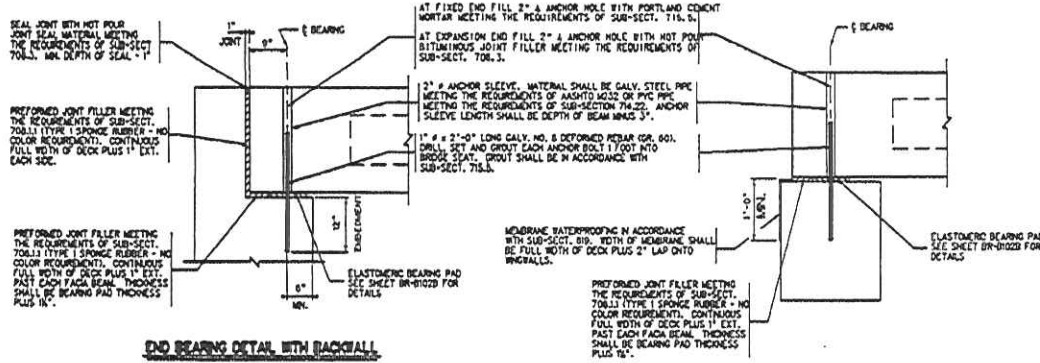

END BEARING DETAIL WITH BACKFALL

END BEARING DETAIL WITHOUT BACKFALL

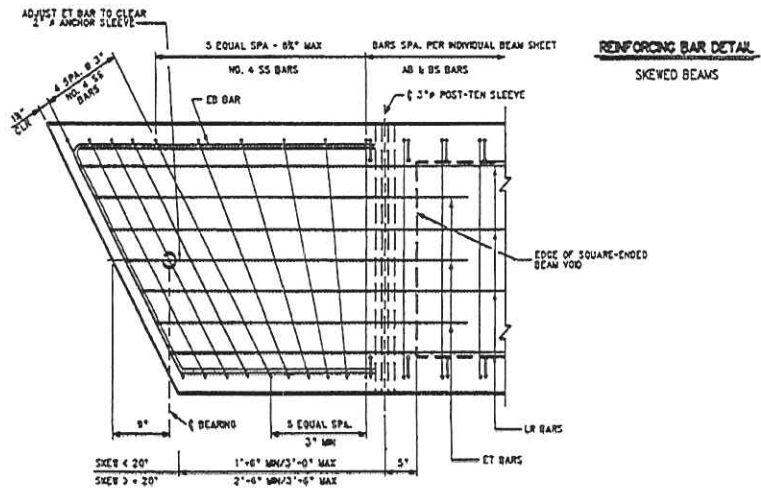
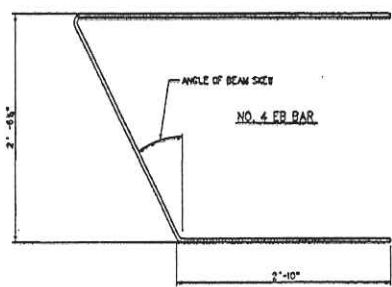
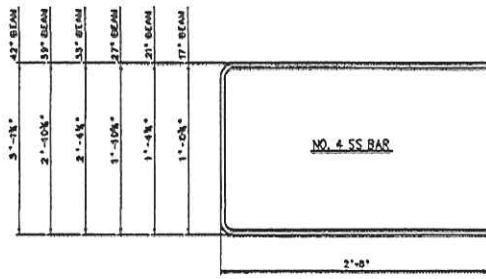

REINFORCING BAR DETAIL SKEWED BEAMS

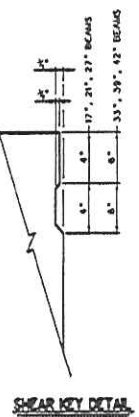

END BLOCK DETAIL - SKEWED BEAMS W/O POST-TEN. ACCESS POCKET

THIS SHEET SHALL BE USED IN CONJUNCTION WITH STANDARD SHEETS BR-8102A & B THRU BR-8102A & B, BR-8100, BR-8101, BR-8102B, BR-8103, BR-8104, BR-8105A & B AND BR-8106 AS APPROPRIATE.

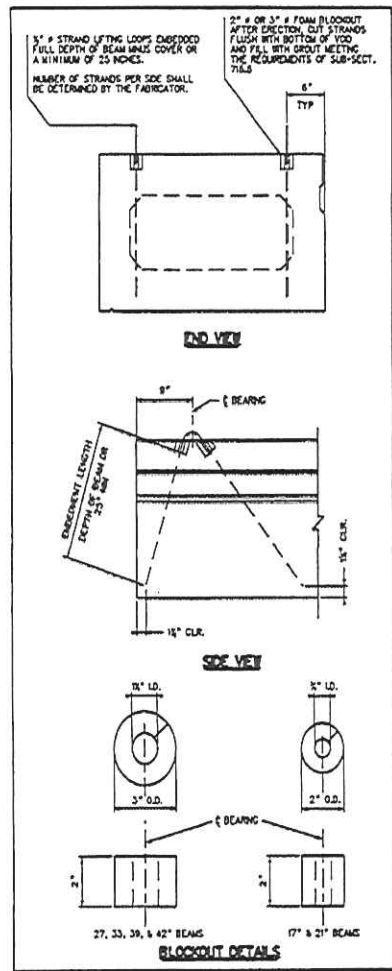

LIFTING DETAILS

SHEET BR-8102A
PRESTRESSED CONCRETE
BEAM SKEWED END
REINFORCING DETAILS

NO.	REVISION	DATE	BY:

WEST VIRGINIA DEPARTMENT OF TRANSPORTATION
DIVISION OF HIGHWAYS
ENGINEERING DIVISION

DESIGNED	DATE	CHECKED	DATE
NRA	09/10	TWB	09/10
DRAWN	DATE	REVIEWED	DATE
NRA	09/10	TWB	09/10

SLAB FORK BRIDGE
LOGAN COUNTY

SHEET
00 of 00-1
DESIGN NUMBER
00

14-SEP-2010 11:37 S:\WORKSPACE - HHS\PROJECTS FOR VDOT\Highway\Road Drawings\BR-8102A.dwg User:RJC_5/25/10

PROJECT NUMBERS		DISTRICT	COUNTY	SHEET NO.	TOTAL
STATE	FEDERAL				
\$323-14-2.67	N.A.	2	LOGAN	00	00

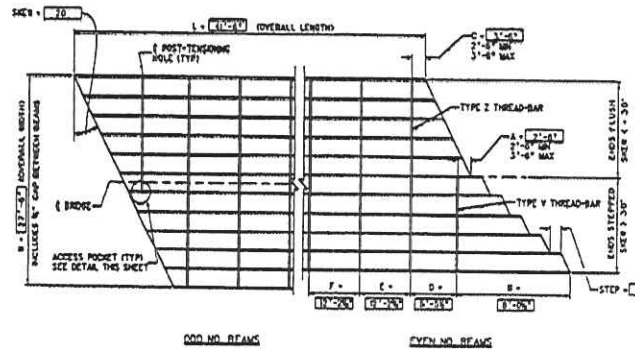

POST-TENSIONING BAR SPACING PLAN
SHEET > = 20'

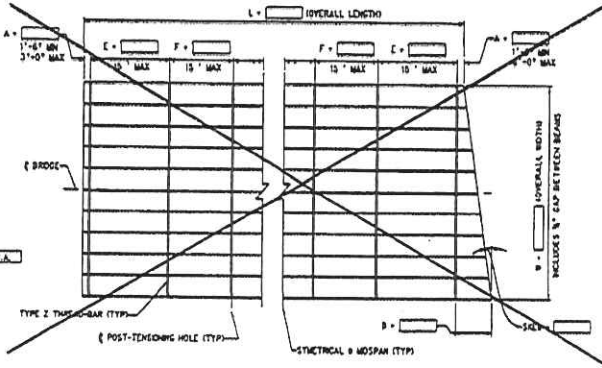

POST-TENSIONING BAR SPACING PLAN
NORMAL OR SHEAR < 20'

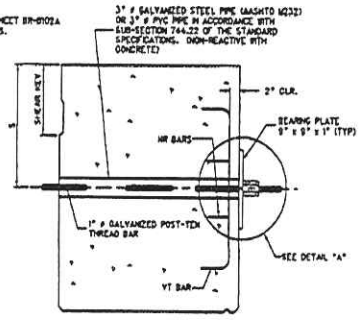

POST-TENSIONING BAR DETAILS

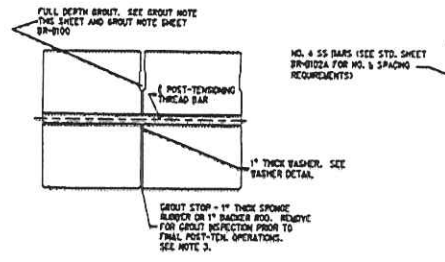

GROUT DETAILS

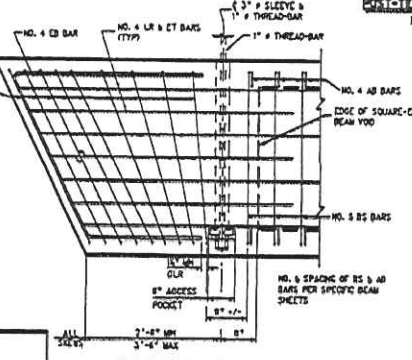

SHEAR REINFORCEMENT DETAIL
BEAMS WITH ACCESS POCKETS

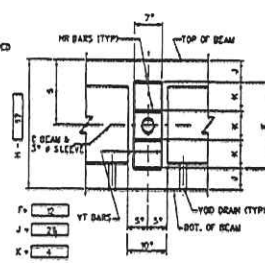

REINFORCING DETAILS @ DIAPHRAGM
EXTERIOR BEAM @ POCKETS ONLY

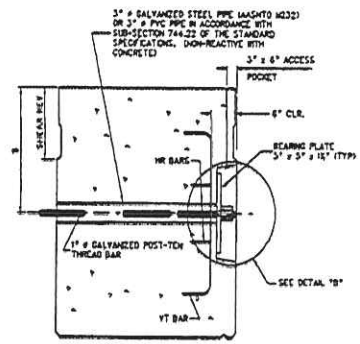

ACCESS POCKET, END POST-TENSIONING BAR

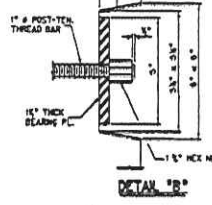

DETAIL 'B'

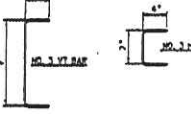

DETAIL 'A'

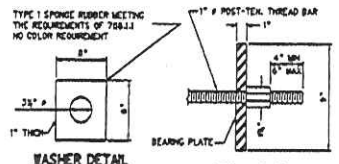

WASHER DETAIL

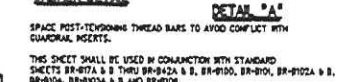

REINFORCING BAR DETAIL
ALL BARS GR 60 - EPOXY COATED

- PROCEDURE NOTES**
- INSTALL ONE INCH THICK WASHER AND GROUT STOP BY GLUING TO ONE END. FOR THE ENTIRE LENGTH OF EACH BEAM PRIOR TO SETTING BEAMS. GLUE SHALL BE AN APPROVED CONSTRUCTION TYPE GLUE OR EPOXY ADHESIVE. GROUT STOP MAY BE INSTALLED AFTER BEAMS ARE SET.
 - GLUE A 2" x 2" x 3" PIECE OF PRESSURE TREATED PLYWOOD AT EACH THREAD-BAR LOCATION TO INSURE THAT A 1/2" GAP IS OBTAINED. PLYWOOD SPACERS TO BE OFFSET APPROXIMATELY 2 FEET FROM THE THREAD-BAR HOLE AND CENTERED ON THE HOLE DEPTH. PLYWOOD SPACERS ARE REQUIRED ON ONLY ONE BEAM EDGE FACE OF ADJUTING BEAMS. AFTER THE BEAMS ARE SET AND THE THREAD-BARS INSTALLED, PULL THE ENTIRE SUPERSTRUCTURE TOGETHER BY APPLYING A POST-TENSIONING FORCE OF APPROXIMATELY 5000 POUNDS. AT THIS STAGE THE GAP BETWEEN BEAMS SHALL BE A MINIMUM 1/2" WITH ALL SPACES REMOVED. RECORD THE ACTUAL FORCE APPLIED.
 - FILL THE GAP BETWEEN BEAMS AND WASHER FULL DEPTH WITH THE PRE-APPROVED, PRE-TESTED GROUT MIXTURE. FROM EACH BATCH, PREPARE JOB CONTROL ABOUT GIBBS FOR THREE AND SEVEN DAY TESTS. THESE JOB CONTROL SAMPLES WILL BE USED TO DETERMINE WHEN THE GROUT HAS ATTAINED A MINIMUM COMPRESSIVE STRENGTH OF 4000 PSI. A MINIMUM OF THREE SPECIMENS PER TEST SHALL BE OBTAINED AND THE AVERAGE OF THE TEST RESULTS USED. ACCEPTANCE SAMPLING AND TESTING OF THE GROUT IS THE RESPONSIBILITY OF THE CONTRACTOR HOWEVER, A REPRESENTATIVE OF THE WYOM SHALL WITNESS ALL OF THE ACCEPTANCE SAMPLING AND TESTING.

TEST PROCEDURE SHALL BE ASTM C109 AS MODIFIED BY ASTM C1097. IN NO INSTANCE SHALL THE CONTRACTOR PROCEED WITH POST-TENSIONING OR OTHER BEAM ERECTION PROCEDURES UNTIL THE REQUIRED MINIMUM GROUT STRENGTH IS OBTAINED AND VERIFIED BY THE ENGINEER. IN THE EVENT THAT THE MINIMUM GROUT STRENGTH IS NOT OBTAINED, THE ENGINEER SHALL BE NOTIFIED AND CORRECTIVE ACTION TAKEN AT THE DISCRETION OF THE ENGINEER. SEE SHEAR KEY GROUT NOTE, SHEET BR-8100 FOR ADDITIONAL REQUIREMENTS.

AFTER THE GROUT HAS REACHED AN INITIAL SET CONDITION AND PRIOR TO ANY FINAL POST-TENSIONING PROCEDURES, THE CONTRACTOR SHALL REMOVE THE GROUT STOP AND INSPECT THE GROUT FOR VOIDS OR OTHER DEFICIENCIES. ANY VOIDS DEEPER THAN 2" FROM THE BOTTOM SHALL BE REGRADED IN A MANNER ACCEPTABLE TO THE ENGINEER.
 - AFTER GROUT AS BEEN PLACED AND REACHED IT'S MINIMUM COMPRESSIVE STRENGTH OF 4000 PSI AND HAS CURED A MINIMUM OF 3 DAYS, APPLY SIZE OF THE FINAL POST-TENSIONING FORCE TO ALL THREAD-BARS. TIGHTEN BEAM ENDS TO MIDSPAN. AFTER ALL THREAD-BARS HAVE BEEN TIGHTENED TO SOL, APPLY THE REMAINING PERCENTAGE OF FINAL POST-TENSIONING FORCE, TIGHTENING IN THE SAME SEQUENCE AS THE FIRST STAGE OF FINAL TENSIONING.
 - MEASURE AND RECORD IN THE ELONGATION TABLE, THIS SHEET, THE ACTUAL TOTAL ELONGATION OF EACH THREAD-BAR. COMPARE THE MEASURED ELONGATION TO THE CALCULATED ELONGATION. A SIGNIFICANT DIFFERENCE BETWEEN MEASURED AND CALCULATED ELONGATIONS COULD INDICATE IMPROPER JACKING TECHNIQUES, FAULTY MATERIALS, FAULTY JACKS, OR IMPROPERLY CALIBRATED JACKS. IF THE DIFFERENCE IS GREATER THAN 10% THEN THE JACK SHALL BE RE-CALIBRATED AND THE JACKING TECHNIQUE ESTABLISHED. IF, AFTER THE ABOVE STEPS ARE TAKEN, THE PERCENTAGE DIFFERENCE IS GREATER THAN 10% THEN THE ENGINEER SHALL BE NOTIFIED AND CORRECTIVE ACTION TAKEN AT THE DISCRETION OF THE ENGINEER. ALL COSTS INVOLVED IN CORRECTION SHALL BE AT THE CONTRACTOR'S EXPENSE.
 - REMOVE EXCESS THREAD-BAR LEAVING 4" TO 6" PAST THE NUT. DO NOT TRIM THREAD-BARS BY TOP CUTTING. TRIM-UP TRIMMED ENDS WITH GALVANIZED OR EQUAL.
 - INSTALL ANCHOR BOLTS AS DETAILED ON STANDARD SHEETS BR-8100 AND BR-8102.

FINAL POST-TENSIONING FORCE
TYPE 2 BARS = 80 KIPS
TYPE Y BARS = 40 KIPS

SPAN	1
SKEW	20'-0"
L	41'-8"
V	27'-8"
A	2'-6"
B	8'-0"
C	3'-6"
D	8'-5 1/2"
E	12'-0"
F	12'-0"
STEP	N.A.

BEAM SIZE	REINFORCEMENT BAR DIM	SPACING	DIST	
	F	J	K	S
	IN.	IN.	IN.	IN.
17	12	2 1/2	4	8 1/2
21	12	4 1/2	4	10 1/2
27	18	4 1/2	4	13 1/2
33	24	4 1/2	8	14 1/2
39	30	4 1/2	10	16 1/2
42	33	4 1/2	11	21

PRE-TEST STRENGTH	3 DAY IPS	7 DAY IPS
JOB CONTROL STRENGTH		
GROUT TYPE & MANUFACTURER		

BAR	FORMULA	LENGTH
V(EVEN)	L-2'	N.A.
Z	8"	20'-6"
V(ODD)	L-4"	17'-2"

BAR	CODE	CALC.	MEASURED													
			NO. 1	NO. 2	NO. 3	NO. 4	NO. 5	NO. 6	NO. 7	NO. 8	NO. 9	NO. 10				
Z	Q	17'-2"	1.000													
V	Q	17'-2"	2.200													

WEST VIRGINIA DEPARTMENT OF TRANSPORTATION DIVISION OF HIGHWAYS ENGINEERING DIVISION				DESIGNED NRA	DATE 09/10	CHECKED TWB	DATE 09/10	SLAB FORK BRIDGE LOGAN COUNTY		SHEET BR-B103 PRESTRESSED CONCRETE BEAM TRAVERSE POST-TENSIONING DETAILS		SHEET 00 OF 03 DESIGN NUMBER
NO.	REVISION	DATE	BY:	DRAWN NRA	09/10	TRB	09/10					

14-336-2-2020 (REV) 8/2018 - Repro'd/ASB for NCDOT use only. Do not Distribute/Repro'd/ASB for NCDOT

PROJECT NUMBERS					SHEET NO.	TOTAL
STATE	FEDERAL	DISTRICT	COUNTY	NO.		
3323-14-2.87	N.A.	2	LOGAN	00	00	

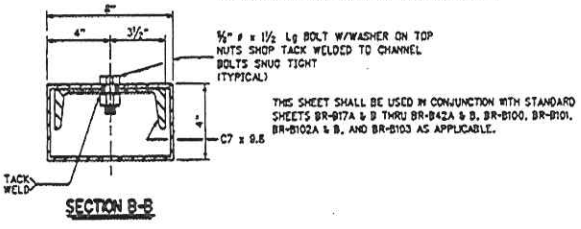
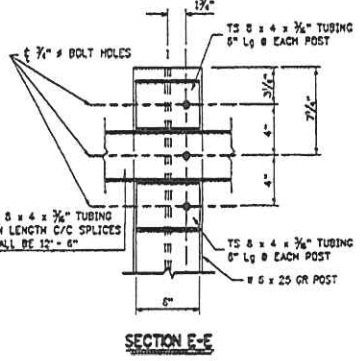
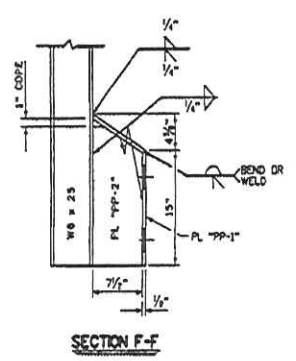
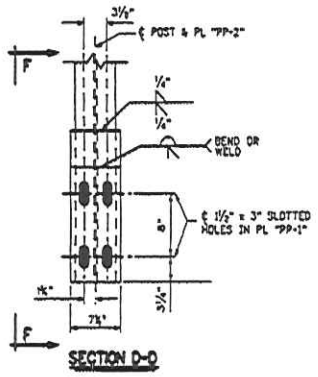
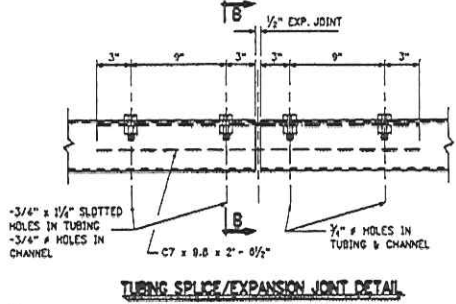
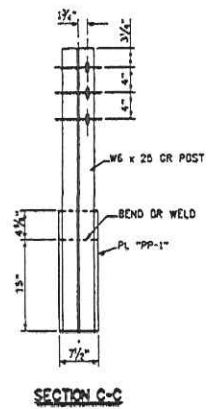
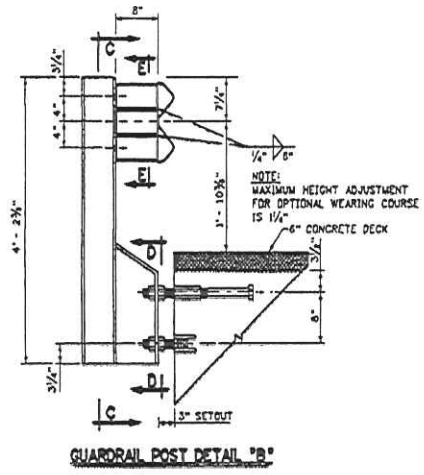
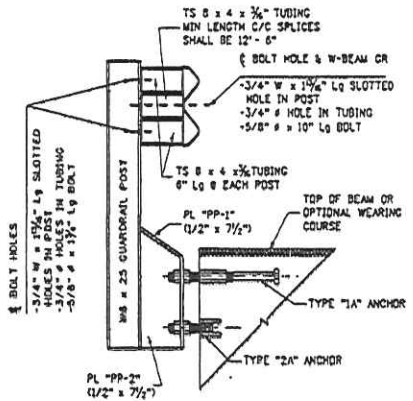
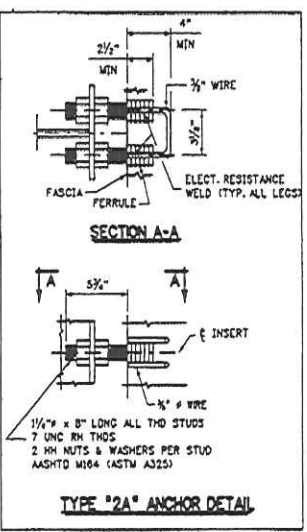
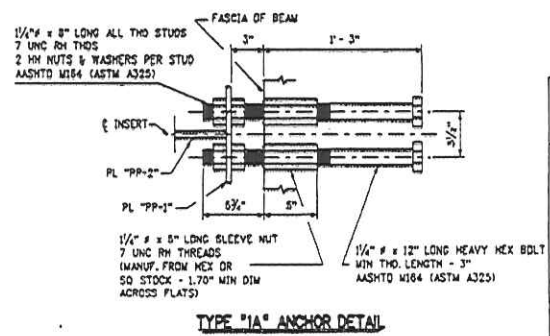
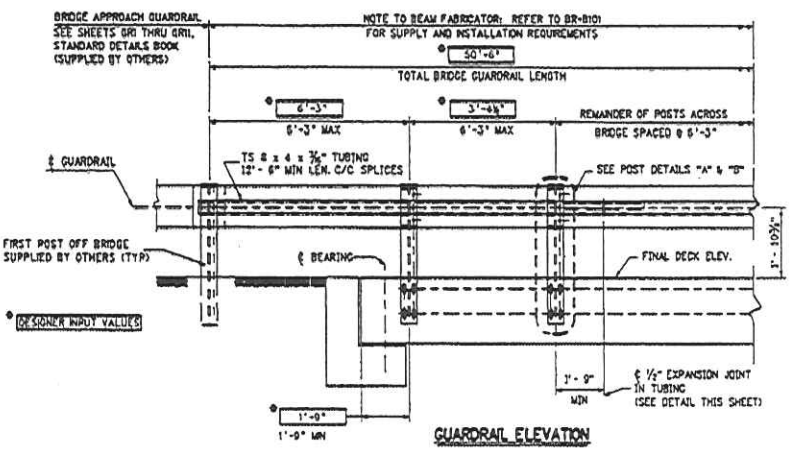

NO.	REVISION	DATE	BY

WEST VIRGINIA DEPARTMENT OF TRANSPORTATION
DIVISION OF HIGHWAYS
ENGINEERING DIVISION

DESIGNED	DATE	CHECKED	DATE
NRA	09/10	TWB	09/10
DRAWN	DATE	REVIEWED	DATE
NRA	09/10	TWB	09/10

SLAB FORK BRIDGE
LOGAN COUNTY

SHEET BR-B104
PRESTRESSED CONCRETE BEAM GUARDRAIL SYSTEM
DESIGN & ASSEMBLY DETAILS

SHEET NO.	TOTAL SHEETS
00 OF 03	03

11-SEP-2010 11:18 S:\PROJECTS\14-2.87\BR-B104\BR-B104.DWG PLOT: 11/10/10 11:18 AM

PROJECT NUMBERS		DISTRICT	COUNTY	SHEET NO.	TOTAL
STATE	FEDERAL				
5323-14-2.67	N.A.	2	LOGAN	00	00

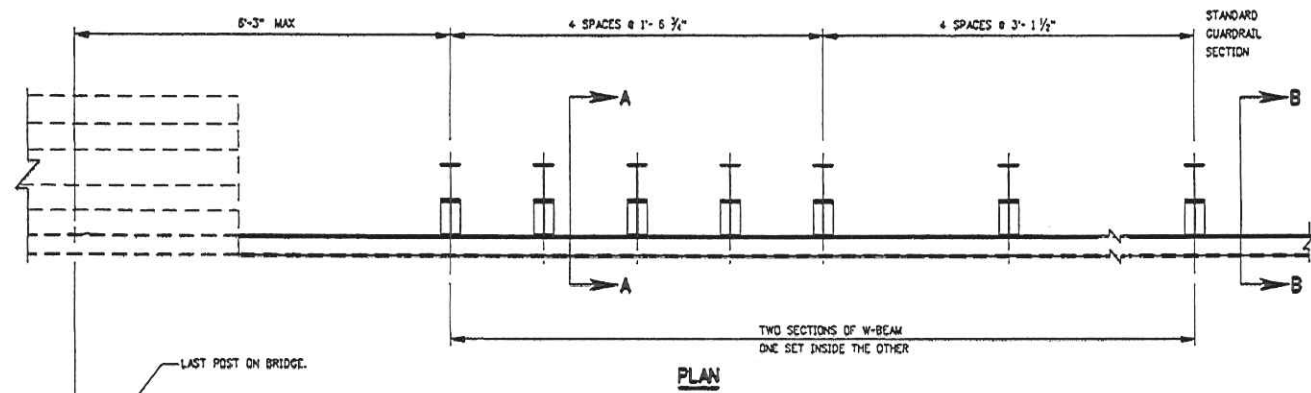

- NOTES**
1. THIS GUARDRAIL TRANSITION IS APPROPRIATE FOR CONNECTION TO GUARDRAIL ON BRIDGE.
 2. W-BEAM IS NOT BOLTED TO POSTS AT POSTS 2 THROUGH 4 AND POST 6.
 3. SEE STANDARD SHEET BR-B104 FOR ANCHOR DETAILS.
 4. THERE IS NO SEPARATE PAY ITEM FOR THIS CONNECTION AND ALL COMPONENTS AS DETAILED HEREIN SHALL BE INCLUDED IN THE CONTRACT PRICE FOR GUARDRAIL.

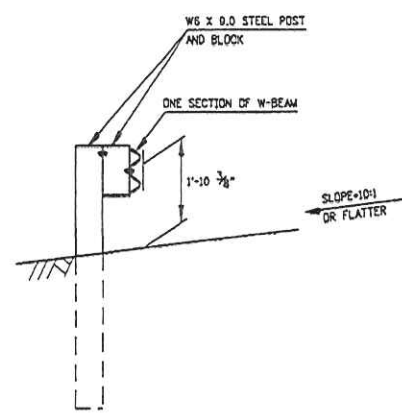
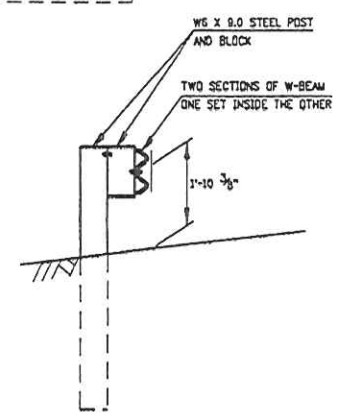
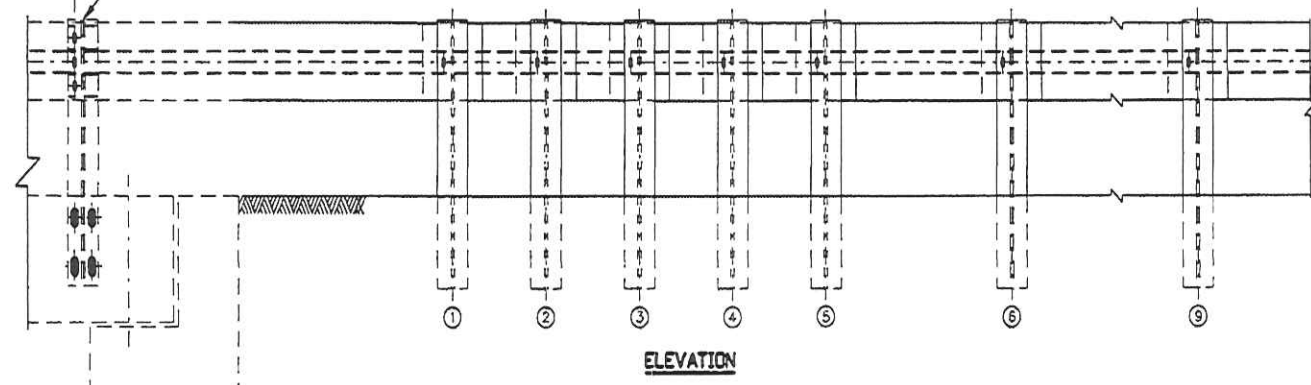

NO.	REVISION	DATE	BY

WEST VIRGINIA DEPARTMENT OF TRANSPORTATION DIVISION OF HIGHWAYS ENGINEERING DIVISION			
DESIGNED	DATE	CHECKED	DATE
NRA	09/10	TWB	09/10
DRAWN	DATE	REVIEWED	DATE
NRA	09/10	TWB	09/10

SLAB FORK BRIDGE
LOGAN COUNTY

SHEET BR-B106

PRESTRESSED CONCRETE
BEAM GUARDRAIL SYSTEMS
DESIGN & ASSEMBLY DETAILS

SHEET
00 of 00
DESIGN NUMBER

14-SEP-2010 11:48 S:\V\B106 - Report\3163 Fork Slab\Drawings\1 Post\beam\BR-B106_0001.rvt

State of West Virginia

VENDOR PREFERENCE CERTIFICATE

Certification and application* is hereby made for Preference in accordance with West Virginia Code, §5A-3-37. (Does not apply to construction contracts). West Virginia Code, §5A-3-37, provides an opportunity for qualifying vendors to request (at the time of bid) preference for their residency status. Such preference is an evaluation method only and will be applied only to the cost bid in accordance with the West Virginia Code. This certificate for application is to be used to request such preference. The Purchasing Division will make the determination of the Resident Vendor Preference, if applicable.

- 1. Application is made for 2.5% resident vendor preference for the reason checked: Bidder is an individual resident vendor and has resided continuously in West Virginia for four (4) years immediately preceding the date of this certification; or, Bidder is a partnership, association or corporation resident vendor and has maintained its headquarters or principal place of business continuously in West Virginia for four (4) years immediately preceding the date of this certification; or 80% of the ownership interest of Bidder is held by another individual, partnership, association or corporation resident vendor who has maintained its headquarters or principal place of business continuously in West Virginia for four (4) years immediately preceding the date of this certification; or, Bidder is a nonresident vendor which has an affiliate or subsidiary which employs a minimum of one hundred state residents and which has maintained its headquarters or principal place of business within West Virginia continuously for the four (4) years immediately preceding the date of this certification; or,
2. Application is made for 2.5% resident vendor preference for the reason checked: Bidder is a resident vendor who certifies that, during the life of the contract, on average at least 75% of the employees working on the project being bid are residents of West Virginia who have resided in the state continuously for the two years immediately preceding submission of this bid; or,
3. Application is made for 2.5% resident vendor preference for the reason checked: Bidder is a nonresident vendor employing a minimum of one hundred state residents or is a nonresident vendor with an affiliate or subsidiary which maintains its headquarters or principal place of business within West Virginia employing a minimum of one hundred state residents who certifies that, during the life of the contract, on average at least 75% of the employees or Bidder's affiliate's or subsidiary's employees are residents of West Virginia who have resided in the state continuously for the two years immediately preceding submission of this bid; or,
4. Application is made for 5% resident vendor preference for the reason checked: Bidder meets either the requirement of both subdivisions (1) and (2) or subdivision (1) and (3) as stated above; or,
5. Application is made for 3.5% resident vendor preference who is a veteran for the reason checked: Bidder is an individual resident vendor who is a veteran of the United States armed forces, the reserves or the National Guard and has resided in West Virginia continuously for the four years immediately preceding the date on which the bid is submitted; or,
6. Application is made for 3.5% resident vendor preference who is a veteran for the reason checked: Bidder is a resident vendor who is a veteran of the United States armed forces, the reserves or the National Guard, if, for purposes of producing or distributing the commodities or completing the project which is the subject of the vendor's bid and continuously over the entire term of the project, on average at least seventy-five percent of the vendor's employees are residents of West Virginia who have resided in the state continuously for the two immediately preceding years.

Bidder understands if the Secretary of Revenue determines that a Bidder receiving preference has failed to continue to meet the requirements for such preference, the Secretary may order the Director of Purchasing to: (a) reject the bid; or (b) assess a penalty against such Bidder in an amount not to exceed 5% of the bid amount and that such penalty will be paid to the contracting agency or deducted from any unpaid balance on the contract or purchase order.

By submission of this certificate, Bidder agrees to disclose any reasonably requested information to the Purchasing Division and authorizes the Department of Revenue to disclose to the Director of Purchasing appropriate information verifying that Bidder has paid the required business taxes, provided that such information does not contain the amounts of taxes paid nor any other information deemed by the Tax Commissioner to be confidential.

Under penalty of law for false swearing (West Virginia Code, §61-5-3), Bidder hereby certifies that this certificate is true and accurate in all respects; and that if a contract is issued to Bidder and if anything contained within this certificate changes during the term of the contract, Bidder will notify the Purchasing Division in writing immediately.

Bidder: EASTERN VAULT Co., Inc. Signed: BRIAN P. STRUBLE
Date: 4-7-2012 Title: GENERAL MANAGER

*Check any combination of preference consideration(s) indicated above, which you are entitled to receive.

STATE OF WEST VIRGINIA
Purchasing Division

PURCHASING AFFIDAVIT

West Virginia Code §5A-3-10a states: No contract or renewal of any contract may be awarded by the state or any of its political subdivisions to any vendor or prospective vendor when the vendor or prospective vendor or a related party to the vendor or prospective vendor is a debtor and the debt owed is an amount greater than one thousand dollars in the aggregate.

DEFINITIONS:

"Debt" means any assessment, premium, penalty, fine, tax or other amount of money owed to the state or any of its political subdivisions because of a judgment, fine, permit violation, license assessment, defaulted workers' compensation premium, penalty or other assessment presently delinquent or due and required to be paid to the state or any of its political subdivisions, including any interest or additional penalties accrued thereon.

"Debtor" means any individual, corporation, partnership, association, limited liability company or any other form or business association owing a debt to the state or any of its political subdivisions. "Political subdivision" means any county commission; municipality; county board of education; any instrumentality established by a county or municipality; any separate corporation or instrumentality established by one or more counties or municipalities, as permitted by law; or any public body charged by law with the performance of a government function or whose jurisdiction is coextensive with one or more counties or municipalities. "Related party" means a party, whether an individual, corporation, partnership, association, limited liability company or any other form or business association or other entity whatsoever, related to any vendor by blood, marriage, ownership or contract through which the party has a relationship of ownership or other interest with the vendor so that the party will actually or by effect receive or control a portion of the benefit, profit or other consideration from performance of a vendor contract with the party receiving an amount that meets or exceed five percent of the total contract amount.

EXCEPTION: The prohibition of this section does not apply where a vendor has contested any tax administered pursuant to chapter eleven of this code, workers' compensation premium, permit fee or environmental fee or assessment and the matter has not become final or where the vendor has entered into a payment plan or agreement and the vendor is not in default of any of the provisions of such plan or agreement.

Under penalty of law for false swearing (*West Virginia Code §61-5-3*), it is hereby certified that the vendor affirms and acknowledges the information in this affidavit and is in compliance with the requirements as stated.

WITNESS THE FOLLOWING SIGNATURE

Vendor's Name: EASTERN VAULT CO., INC.

Authorized Signature: *Brian P. Struble* BRIAN P. STRUBLE Date: 4-7-2012

State of West Virginia

County of Mercer, to-wit:

Taken, subscribed, and sworn to before me this 7 day of April, 2012.

My Commission expires Oct 18, 2015.

AFFIX SEAL HERE

NOTARY PUBLIC. *Frances J. McKinney*

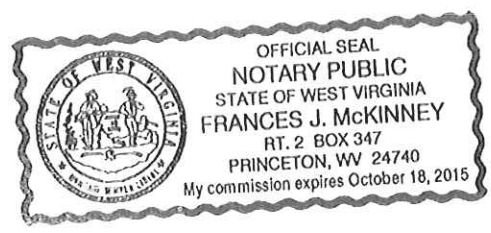

Please use this document for technical questions, posing in a question format

Please refer to the section your question is in reference to.

Technical questions for RFQ# _____

Vendor Name: _____

Questions:
