



State of West Virginia
 Department of Administration
 Purchasing Division
 2019 Washington Street East
 Post Office Box 50130
 Charleston, WV 25305-0130

Request for Quotation

RFQ NUMBER
 WSH11134

PAGE
 1

ADDRESS CORRESPONDENCE TO ATTENTION OF
 ROBERTA WAGNER
 304-558-0067

Corporate address

RFQ COPY
 TYPE NAME/ADDRESS HERE
 Interline Brands, Inc. d/b/a Sexaver
 701 San Marco Blvd.
 Attn: Bid Team, 14th Floor
 Jacksonville, FL 32207

HEALTH AND HUMAN RESOURCES
 WILLIAM R. SHARPE JR. HOSPITAL
 CENTRAL RECEIVING
 936 SHARPE HOSPITAL ROAD
 WESTON, WV 26452
 304-269-1210

Corporate fax 800-476-5848 - phone 800-476-5830 or x115388
 email address: institutional-governmentbidsteam@interlinebrands.com

DATE PRINTED	TERMS OF SALE	SHIP VIA	FOB	FREIGHT TERMS
03/23/2011				

BID OPENING DATE: 04/14/2011 BID OPENING TIME 01:30PM

LINE	QUANTITY	UOP	CAT NO	ITEM NUMBER	UNIT PRICE	AMOUNT
ADDENDUM NO. 1						
1. TO CONFIRM THAT THE MANDATORY PRE-BID MEETING WILL TAKE PLACE ON 3/29/2011 AT 10:00 AM IN CONF. ROOM F, AT WILLIAM R. SHARPE JR. HOSPITAL LOCATED AT 936 SHARPE HOSPITAL ROAD, WESTON, WV 26452.						
2. ADDENDUM ACKNOWLEDGMENT IS ATTACHED. THIS DOCUMENT SHOULD BE SIGNED AND RETURNED WITH YOUR BID. FAILURE TO SIGN AND RETURN MAY RESULT IN DISQUALIFICATION OF YOUR BID.						
EXHIBIT 10						
REQUISITION NO.: WSH11134						
ADDENDUM ACKNOWLEDGEMENT						
I HEREBY ACKNOWLEDGE RECEIPT OF THE FOLLOWING CHECKED ADDENDUM(S) AND HAVE MADE THE NECESSARY REVISIONS TO MY PROPOSAL, PLANS AND/OR SPECIFICATION, ETC.						
ADDENDUM NO.'S:						
✓	NO. 1		effective 3/23/11		
✓	NO. 2		effective 4/1/11		
	NO. 3				

SEE REVERSE SIDE FOR TERMS AND CONDITIONS

SIGNATURE *Fred M. Bravo* Fred M. Bravo TELEPHONE 800-476-5830 x105095 DATE 4/4/11

TITLE V.P. of Field Sales FEIN 22-2232386 ADDRESS CHANGES TO BE NOTED ABOVE

WHEN RESPONDING TO RFQ, INSERT NAME AND ADDRESS IN SPACE ABOVE LABELED 'VENDOR'

ORIGINAL

RECEIVED
 2011 APR 14 A 10:02
 PURCHASING DIVISION
 STATE OF WV

GENERAL TERMS & CONDITIONS REQUEST FOR QUOTATION (RFQ) AND REQUEST FOR PROPOSAL (RFP)

1. Awards will be made in the best interest of the State of West Virginia.
2. The State may accept or reject in part, or in whole, any bid.
3. Prior to any award, the apparent successful vendor must be properly registered with the Purchasing Division and have paid the required \$125 fee.
4. All services performed or goods delivered under State Purchase Order/Contracts are to be continued for the term of the Purchase Order/Contracts, contingent upon funds being appropriated by the Legislature or otherwise being made available. In the event funds are not appropriated or otherwise available for these services or goods this Purchase Order/Contract becomes void and of no effect after June 30.
5. Payment may only be made after the delivery and acceptance of goods or services.
6. Interest may be paid for late payment in accordance with the *West Virginia Code*.
7. Vendor preference will be granted upon written request in accordance with the *West Virginia Code*.
8. The State of West Virginia is exempt from federal and state taxes and will not pay or reimburse such taxes.
9. The Director of Purchasing may cancel any Purchase Order/Contract upon 30 days written notice to the seller.
10. The laws of the State of West Virginia and the *Legislative Rules* of the Purchasing Division shall govern the purchasing process.
11. Any reference to automatic renewal is hereby deleted. The Contract may be renewed only upon mutual written agreement of the parties.
12. **BANKRUPTCY:** In the event the vendor/contractor files for bankruptcy protection, the State may deem this contract null and void, and terminate such contract without further order.
13. **HIPAA BUSINESS ASSOCIATE ADDENDUM:** The West Virginia State Government HIPAA Business Associate Addendum (BAA), approved by the Attorney General, is available online at www.state.wv.us/admin/purchase/vrc/hipaa.htm and is hereby made part of the agreement. Provided that the Agency meets the definition of a Cover Entity (45 CFR §160.103) and will be disclosing Protected Health Information (45 CFR §160.103) to the vendor.
14. **CONFIDENTIALITY:** The vendor agrees that he or she will not disclose to anyone, directly or indirectly, any such personally identifiable information or other confidential information gained from the agency, unless the individual who is the subject of the information consents to the disclosure in writing or the disclosure is made pursuant to the agency's policies, procedures, and rules. Vendor further agrees to comply with the Confidentiality Policies and Information Security Accountability Requirements, set forth in <http://www.state.wv.us/admin/purchase/privacy/noticeConfidentiality.pdf>.
15. **LICENSING:** Vendors must be licensed and in good standing in accordance with any and all state and local laws and requirements by any state or local agency of West Virginia, including, but not limited to, the West Virginia Secretary of State's Office, the West Virginia Tax Department, and the West Virginia Insurance Commission. The vendor must provide all necessary releases to obtain information to enable the director or spending unit to verify that the vendor is licensed and in good standing with the above entities.
16. **ANTITRUST:** In submitting a bid to any agency for the State of West Virginia, the bidder offers and agrees that if the bid is accepted the bidder will convey, sell, assign or transfer to the State of West Virginia all rights, title and interest in and to all causes of action it may now or hereafter acquire under the antitrust laws of the United States and the State of West Virginia for price fixing and/or unreasonable restraints of trade relating to the particular commodities or services purchased or acquired by the State of West Virginia. Such assignment shall be made and become effective at the time the purchasing agency tenders the initial payment to the bidder.

I certify that this bid is made without prior understanding, agreement, or connection with any corporation, firm, limited liability company, partnership, or person or entity submitting a bid for the same material, supplies, equipment or services and is in all respects fair and without collusion or Fraud. I further certify that I am authorized to sign the certification on behalf of the bidder or this bid.

INSTRUCTIONS TO BIDDERS

1. Use the quotation forms provided by the Purchasing Division. Complete all sections of the quotation form.
2. Items offered must be in compliance with the specifications. Any deviation from the specifications must be clearly indicated by the bidder. Alternates offered by the bidder as **EQUAL** to the specifications must be clearly defined. A bidder offering an alternate should attach complete specifications and literature to the bid. The Purchasing Division may waive minor deviations to specifications.
3. Unit prices shall prevail in case of discrepancy. All quotations are considered F.O.B. destination unless alternate shipping terms are clearly identified in the quotation.
4. All quotations must be delivered by the bidder to the office listed below prior to the date and time of the bid opening. Failure of the bidder to deliver the quotations on time will result in bid disqualifications: Department of Administration, Purchasing Division, 2019 Washington Street East, P.O. Box 50130, Charleston, WV 25305-0130
5. Communication during the solicitation, bid, evaluation or award periods, except through the Purchasing Division, is strictly prohibited (W.Va. C.S.R. §148-1-6.6).



State of West Virginia
 Department of Administration
 Purchasing Division
 2019 Washington Street East
 Post Office Box 50130
 Charleston, WV 25305-0130

Request for Quotation

RFQ NUMBER
 WSH11134

PAGE
 2

ADDRESS CORRESPONDENCE TO ATTENTION OF
 ROBERTA WAGNER
 304-558-0067

RFQ COPY
 TYPE NAME/ADDRESS HERE

Interline Brands, Inc.
 d/b/a Sexauer®

See pg #1

HEALTH AND HUMAN RESOURCES
 WILLIAM R. SHARPE JR. HOSPITAL
 CENTRAL RECEIVING
 936 SHARPE HOSPITAL ROAD
 WESTON, WV 26452 304-269-1210

DATE PRINTED	TERMS OF SALE	SHIP VIA	F.O.B.	FREIGHT TERMS
03/23/2011				

BID OPENING DATE: 04/14/2011 BID OPENING TIME 01:30PM

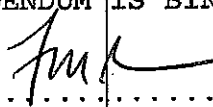
LINE	QUANTITY	UOP	CAT NO	ITEM NUMBER	UNIT PRICE	AMOUNT
NO. 4					
NO. 5					
<p>I UNDERSTAND THAT FAILURE TO CONFIRM THE RECEIPT OF THE ADDENDUM(S) MAY BE CAUSE FOR REJECTION OF BIDS.</p> <p>VENDOR MUST CLEARLY UNDERSTAND THAT ANY VERBAL REPRESENTATION MADE OR ASSUMED TO BE MADE DURING ANY ORAL DISCUSSION HELD BETWEEN VENDOR'S REPRESENTATIVES AND ANY STATE PERSONNEL IS NOT BINDING. ONLY THE INFORMATION ISSUED IN WRITING AND ADDED TO THE SPECIFICATIONS BY AN OFFICIAL ADDENDUM IS BINDING.</p> <p style="text-align: center;">  SIGNATURE Interline Brands, Inc. d/b/a Sexauer COMPANY 4/4/11 DATE </p> <p>NOTE: THIS ADDENDUM ACKNOWLEDGEMENT SHOULD BE SUBMITTED WITH THE BID.</p> <p>REV. 09/21/2009</p> <p style="text-align: center;">END OF ADDENDUM NO. 1</p>						

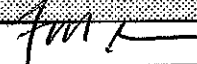
SEE REVERSE SIDE FOR TERMS AND CONDITIONS			
SIGNATURE 	Fred M. Bravo	TELEPHONE 800-474-5830 X115095	DATE 4/4/11
TITLE V.P. of field sales	FEIN 22-2232386	ADDRESS CHANGES TO BE NOTED ABOVE	

WHEN RESPONDING TO RFQ, INSERT NAME AND ADDRESS IN SPACE ABOVE LABELED 'VENDOR'



State of West Virginia
 Department of Administration
 Purchasing Division
 2019 Washington Street East
 Post Office Box 50130
 Charleston, WV 25305-0130

Request for Quotation

RFQ NUMBER
 WSH11134

PAGE
 1

ADDRESS CORRESPONDENCE TO ATTENTION OF
 ROBERTA WAGNER
 304-558-0067

RFQ COPY

Interline Brands
 Attn: Neal Rugel
 61 9th Ave.
 St. Albans, WV 25177

local address
As. See pg 1
of Addendum #7
by corporate address

HEALTH AND HUMAN RESOURCES
 WILLIAM R. SHARPE JR. HOSPITAL
 CENTRAL RECEIVING
 936 SHARPE HOSPITAL ROAD
 WESTON, WV 26452 304-269-1210

DATE PRINTED	TERMS OF SALE	SHIP VIA	FOB	FREIGHT TERMS
04/01/2011				

BID OPENING DATE: 04/14/2011 BID OPENING TIME 01:30PM

LINE	QUANTITY	UOP	CAT NO	ITEM NUMBER	UNIT PRICE	AMOUNT
ADDENDUM NO. 2						
1. QUESTIONS AND ANSWERS ARE ATTACHED. 2. ADDENDUM ACKNOWLEDGEMENT IS ATTACHED. THIS DOCUMENT SHOULD BE SIGNED AND RETURNED WITH YOUR BID. FAILURE TO SIGN AND RETURN MAY RESULT IN DISQUALIFICATION OF YOUR BID. EXHIBIT 10						
REQUISITION NO.: WSH11134						
ADDENDUM ACKNOWLEDGEMENT						
I HEREBY ACKNOWLEDGE RECEIPT OF THE FOLLOWING CHECKED ADDENDUM(S) AND HAVE MADE THE NECESSARY REVISIONS TO MY PROPOSAL, PLANS AND/OR SPECIFICATION, ETC.						
ADDENDUM NO.'S:						
<input checked="" type="checkbox"/> NO. 1 <i>effective 3/23/11</i> <input checked="" type="checkbox"/> NO. 2 <i>effective 4/1/11</i> NO. 3 NO. 4 NO. 5						
I UNDERSTAND THAT FAILURE TO CONFIRM THE RECEIPT OF THE ADDENDUM(S) MAY BE CAUSE FOR REJECTION OF BIDS.						

SEE REVERSE SIDE FOR TERMS AND CONDITIONS

SIGNATURE <i>fm</i> Fred Bravo	TELEPHONE 800-765-830 x115095	DATE 4/4/11
TITLE V. P. Fred Sales	FEIN 22-2232306	ADDRESS CHANGES TO BE NOTED ABOVE

WHEN RESPONDING TO RFQ, INSERT NAME AND ADDRESS IN SPACE ABOVE LABELED 'VENDOR'



State of West Virginia
 Department of Administration
 Purchasing Division
 2019 Washington Street East
 Post Office Box 50130
 Charleston, WV 25305-0130

Request for Quotation

RFQ NUMBER
 WSH11134

PAGE
 2

ADDRESS CORRESPONDENCE TO ATTENTION OF
 ROBERTA WAGNER
 304-558-0067

PROPERTY

RFQ COPY
 TYPE NAME/ADDRESS HERE

Interline Brands, Inc.
 d/b/a Sexauer®

SHIP TO

HEALTH AND HUMAN RESOURCES
 WILLIAM R. SHARPE JR. HOSPITAL
 CENTRAL RECEIVING
 936 SHARPE HOSPITAL ROAD
 WESTON, WV 26452
 304-269-1210

DATE PRINTED	TERMS OF SALE	SHIP VIA	FOB	FREIGHT TERMS
04/01/2011				

BID OPENING DATE: 04/14/2011 BID OPENING TIME 01:30PM

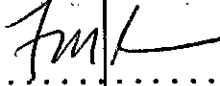
LINE	QUANTITY	UOP	CAT NO	ITEM NUMBER	UNIT PRICE	AMOUNT
<p>VENDOR MUST CLEARLY UNDERSTAND THAT ANY VERBAL REPRESENTATION MADE OR ASSUMED TO BE MADE DURING ANY ORAL DISCUSSION HELD BETWEEN VENDOR'S REPRESENTATIVES AND ANY STATE PERSONNEL IS NOT BINDING. ONLY THE INFORMATION ISSUED IN WRITING AND ADDED TO THE SPECIFICATIONS BY AN OFFICIAL ADDENDUM IS BINDING.</p> <p style="text-align: center;">  SIGNATURE Interline Brands, Inc. / d/b/a Sexauer® COMPANY DATE </p> <p>NOTE: THIS ADDENDUM ACKNOWLEDGEMENT SHOULD BE SUBMITTED WITH THE BID.</p> <p>REV. 09/21/2009</p> <p style="text-align: center;">END OF ADDENDUM NO. 2</p>						

SEE REVERSE SIDE FOR TERMS AND CONDITIONS

SIGNATURE 	Fred M. Bravo	TELEPHONE 800-476-5830 x115095	DATE 4/4/11
TITLE V.P.	FEIN 22-2232384	ADDRESS CHANGES TO BE NOTED ABOVE	

GENERAL TERMS & CONDITIONS REQUEST FOR QUOTATION (RFQ) AND REQUEST FOR PROPOSAL (RFP)

1. Awards will be made in the best interest of the State of West Virginia.
2. The State may accept or reject in part, or in whole, any bid.
3. Prior to any award, the apparent successful vendor must be properly registered with the Purchasing Division and have paid the required \$125 fee.
4. All services performed or goods delivered under State Purchase Order/Contracts are to be continued for the term of the Purchase Order/Contracts, contingent upon funds being appropriated by the Legislature or otherwise being made available. In the event funds are not appropriated or otherwise available for these services or goods this Purchase Order/Contract becomes void and of no effect after June 30.
5. Payment may only be made after the delivery and acceptance of goods or services.
6. Interest may be paid for late payment in accordance with the *West Virginia Code*.
7. Vendor preference will be granted upon written request in accordance with the *West Virginia Code*.
8. The State of West Virginia is exempt from federal and state taxes and will not pay or reimburse such taxes.
9. The Director of Purchasing may cancel any Purchase Order/Contract upon 30 days written notice to the seller.
10. The laws of the State of West Virginia and the *Legislative Rules* of the Purchasing Division shall govern the purchasing process.
11. Any reference to automatic renewal is hereby deleted. The Contract may be renewed only upon mutual written agreement of the parties.
12. **BANKRUPTCY:** In the event the vendor/contractor files for bankruptcy protection, the State may deem this contract null and void, and terminate such contract without further order.
13. **HIPAA BUSINESS ASSOCIATE ADDENDUM:** The West Virginia State Government HIPAA Business Associate Addendum (BAA), approved by the Attorney General, is available online at www.state.wv.us/admin/purchase/vrc/hipaa.htm and is hereby made part of the agreement. Provided that the Agency meets the definition of a Cover Entity (45 CFR §160.103) and will be disclosing Protected Health Information (45 CFR §160.103) to the vendor.
14. **CONFIDENTIALITY:** The vendor agrees that he or she will not disclose to anyone, directly or indirectly, any such personally identifiable information or other confidential information gained from the agency, unless the individual who is the subject of the information consents to the disclosure in writing or the disclosure is made pursuant to the agency's policies, procedures, and rules. Vendor further agrees to comply with the Confidentiality Policies and Information Security Accountability Requirements, set forth in <http://www.state.wv.us/admin/purchase/privacy/noticeConfidentiality.pdf>.
15. **LICENSING:** Vendors must be licensed and in good standing in accordance with any and all state and local laws and requirements by any state or local agency of West Virginia, including, but not limited to, the West Virginia Secretary of State's Office, the West Virginia Tax Department, and the West Virginia Insurance Commission. The vendor must provide all necessary releases to obtain information to enable the director or spending unit to verify that the vendor is licensed and in good standing with the above entities.
16. **ANTITRUST:** In submitting a bid to any agency for the State of West Virginia, the bidder offers and agrees that if the bid is accepted the bidder will convey, sell, assign or transfer to the State of West Virginia all rights, title and interest in and to all causes of action it may now or hereafter acquire under the antitrust laws of the United States and the State of West Virginia for price fixing and/or unreasonable restraints of trade relating to the particular commodities or services purchased or acquired by the State of West Virginia. Such assignment shall be made and become effective at the time the purchasing agency tenders the initial payment to the bidder.

I certify that this bid is made without prior understanding, agreement, or connection with any corporation, firm, limited liability company, partnership, or person or entity submitting a bid for the same material, supplies, equipment or services and is in all respects fair and without collusion or Fraud. I further certify that I am authorized to sign the certification on behalf of the bidder or this bid.

INSTRUCTIONS TO BIDDERS

1. Use the quotation forms provided by the Purchasing Division. Complete all sections of the quotation form.
2. Items offered must be in compliance with the specifications. Any deviation from the specifications must be clearly indicated by the bidder. Alternates offered by the bidder as **EQUAL** to the specifications must be clearly defined. A bidder offering an alternate should attach complete specifications and literature to the bid. The Purchasing Division may waive minor deviations to specifications.
3. Unit prices shall prevail in case of discrepancy. All quotations are considered F.O.B. destination unless alternate shipping terms are clearly identified in the quotation.
4. All quotations must be delivered by the bidder to the office listed below prior to the date and time of the bid opening. Failure of the bidder to deliver the quotations on time will result in bid disqualifications: Department of Administration, Purchasing Division, 2019 Washington Street East, P.O. Box 50130, Charleston, WV 25305-0130
5. Communication during the solicitation, bid, evaluation or award periods, except through the Purchasing Division, is strictly prohibited (W.Va. C.S.R. §148-1-6.6).

Questions and answers for per bid WSH11134

1. We are reviewing the above quote for response. I see that there is a mandatory pre-bid conference scheduled. Are there any other requirements besides what is written in the bid, that must be followed, or additional equipment or labor to be furnished besides what is printed in the bid?
 - Answer: There are no additional requirements other than what is written in the bid. No additional equipment or labor is required.
2. Can you please advise the length of time that we will need to hold our pricing?
 - Answer: Pricing must be held for 90 days.
3. Is it the agency's intent to have 1 shipment or will you require shipments spread out over a period of time?
 - Answer: Agency will accept single or multiple shipments as long as entire order is received by July 1, 2011.
4. The RFQ has listed a few different size grab bars, can you please provide us with the quantities needed for each size?
 - Answer:
 - 15 each at 48 in. long.
 - 13 each at 36 in. long.
 - 1 each at 32 in. long
 - 14 each at 24in.X 24in. corner.
5. Can you please indicate the weight the local preference will carry? If we are not a local vendor, can we strike through this section and mark "not applicable"?
 - Answer: The only time the RVP comes into play is when the low bidder is not in-state and the weight would be the percentage claimed by the in-state vendor. Yes, you can mark "not applicable" on the RVP if it does not apply to you company.

Additional change request: Required delivery date will change from May 1, 2011 to June 30, 2011 to allow for sufficient time for the vendors to manufacture and deliver all products.



State of West Virginia
 Department of Administration
 Purchasing Division
 2019 Washington Street East
 Post Office Box 50130
 Charleston, WV 25305-0130

Request for Quotation

RFQ NUMBER
 WSH11134

PAGE
 1

ADDRESS CORRESPONDENCE TO ATTENTION OF
 ROBERTA WAGNER
 304-558-0067

RFQ COPY

TYPE NAME/ADDRESS HERE

Interline Brands, Inc.
 d/b/a Sexauer®

HEALTH AND HUMAN RESOURCES
 WILLIAM R. SHARPE JR. HOSPITAL
 CENTRAL RECEIVING
 936 SHARPE HOSPITAL ROAD
 WESTON, WV 26452 304-269-1210

DATE PRINTED	TERMS OF SALE	SHIP VIA	F.O.B.	FREIGHT TERMS
03/16/2011				

BID OPENING DATE: 04/14/2011 BID OPENING TIME 01:30PM

LINE	QUANTITY	UOP	CAT NO	ITEM NUMBER	UNIT PRICE	AMOUNT
***** MANDATORY PRE-BID MEETING 3/29/2011 AT 10:00 AM IN CONF. ROOM F, AT WILLIAM R. SHARPE JR. HOSPITAL LOCATE AT 936 SHARPE HOSPITAL ROAD, WESTON, WV 26452. *****						
0001	150	EA		910-65	NO BID	
FLUSH VALVE COVERS PER ATTACHED SPECIFICATIONS REQUEST FOR QUOTATION TO PROVIDE VARIOUS PARTS AND REPLACEMENT PARTS TO MEET NON LOOPING REQUIREMENT REQUIREMENT OF THE OFFICE OF HEALTH FACILITY, LICENSING AND CERTIFICATIONS, PER THE SPECIFICATIONS.						
0002	125	EA		910-65	50.58	6322.50
FLUSH VALVES PER ATTACHED SPECIFICATIONS.						

SEE REVERSE SIDE FOR TERMS AND CONDITIONS

SIGNATURE <i>FMB</i>	Fred M. Bravo	TELEPHONE 800-476-5830 x115095	DATE 4/4/11
TITLE V. P. of Field Sales	FEIN 22-2232386	ADDRESS CHANGES TO BE NOTED ABOVE	

WHEN RESPONDING TO RFQ, INSERT NAME AND ADDRESS IN SPACE ABOVE LABELED 'VENDOR'



State of West Virginia
 Department of Administration
 Purchasing Division
 2019 Washington Street East
 Post Office Box 50130
 Charleston, WV 25305-0130

Request for Quotation

RFQ NUMBER
 WSH11134

PAGE
 2

ADDRESS CORRESPONDENCE TO ATTENTION OF
 ROBERTA WAGNER
 304-558-0067

RFQ COPY
 TYPE NAME/ADDRESS HERE

Interline Brands, Inc.
 d/b/a Sexauer®

HEALTH AND HUMAN RESOURCES
 WILLIAM R. SHARPE JR. HOSPITAL
 CENTRAL RECEIVING
 936 SHARPE HOSPITAL ROAD
 WESTON, WV
 26452 304-269-1210

DATE PRINTED	TERMS OF SALE	SHIP VIA	FOB	FREIGHT TERMS
03/16/2011				

BID OPENING DATE: 04/14/2011 BID OPENING TIME 01:30PM

LINE	QUANTITY	UOP	CAT NO	ITEM NUMBER	UNIT PRICE	AMOUNT
0003	18	EA		910-65	71.67	1290.06
LIGATURE RESISTANT SHOWER HEADS PER ATTACHED SPECS.						
0004	18	EA		910-65	53.44	961.92
QUICK CONNECT HAND HELD SHOWER HEADS PER ATTACHED SPECIFICATIONS.						
<p>MANDATORY PRE-BID</p> <p>A MANDATORY PRE-BID WILL BE HELD ON 3/29/2011 AT 10:00 AM IN CONF. F @ WILLIAM R SHARPE JR. HOSPITAL. ALL INTERESTED PARTIES ARE REQUIRED TO ATTEND THIS MEETING. FAILURE TO ATTEND THE MANDATORY PRE-BID SHALL RESULT I DISQUALIFICATION OF THE BID. NO ONE PERSON MAY REPRESENT MORE THAN ONE BIDDER.</p> <p>AN ATTENDANCE SHEET WILL BE MADE AVAILABLE FOR ALL POTENTIAL BIDDERS TO COMPLETE. THIS WILL SERVE AS THE OFFICIAL DOCUMENT VERIFYING ATTENDANCE AT THE MANDATOR PRE-BID. FAILURE TO PROVIDE YOUR COMPANY AND REPRESENTATIVE NAME ON THE ATTENDANCE SHEET WILL RESULT IN DISQUALIFICATION OF THE BID. THE STATE WILL NOT ACCEPT ANY OTHER DOCUMENTATION TO VERIFY ATTENDANCE. THE BIDDER IS RESPONSIBLE FOR ENSURING THEY HAVE COMPLETED THE INFORMATION REQUIRED ON THE ATTENDANCE SHEET. THE PURCHASING DIVISION AND THE STATE AGENCY WILL NOT ASSUME ANY RESPONSIBILITY FOR A BIDDER-S FAILURE TO COMPLETE THE PRE-BID ATTENDANCE SHEET. IN ADDITION, WE REQUEST THAT ALL POTENTIAL BIDDERS INCLUDE THEIR E-MAIL ADDRESS AND FAX NUMBER.</p>						

① see breakdown next page
 ② spec sheet behind price break down

SEE REVERSE SIDE FOR TERMS AND CONDITIONS

SIGNATURE *Fred M. Bravo* Fred M. Bravo TELEPHONE 800-476-5830 x115095 DATE 4-4-11

TITLE V.P. of Field Sales FEIN 22-2232386 ADDRESS CHANGES TO BE NOTED ABOVE

WHEN RESPONDING TO RFQ, INSERT NAME AND ADDRESS IN SPACE ABOVE LABELED 'VENDOR'

Detail Sheet RFQ #WSW11134

Line #4 Quick Connect Hand Held Shower Heads

Line #4	Sx#029074	18 pcs	\$8.74	\$157.32
	Sx#327338	18 pcs	\$27.05	\$486.90
	Sx#968628	18 pcs	\$10.67	\$192.06
	Sx#49510	18 pcs	\$6.98	\$125.64
			TOTAL	\$961.92

GENERAL PLUMBING SUPPLIES

SHOWER HEADS



BRADLEY Shower Head OEM S24-008 (Old Style - To 1974)



Cat. No.	MFG No.	Description	Type	Finish	Material
052589	S24-008	Shower Head, Comp.	Institutional	Chrome	Brass
052597	S76-004	Core Assy. Only	Institutional	Chrome	Brass
052605	S76-002	Shell Assy. Only	Institutional	Chrome	Brass

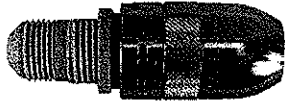

BRADLEY Showerhead OEM S24-072 (After 1974)

Shower Head, Complete



Cat. No.	MFG No.	Description	Type	Finish	Flow Rate	Material
052621	S24-072	Shower Head, Comp.	Institutional	Chrome	2.2 GPM	Brass

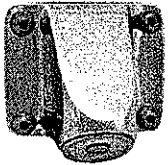

#3

CHICAGO Institutional Showerhead

Adjustable for 20° or 30° spray angle. Includes mounting anchors. 1/2" IPS female inlet. C.P. finish.



Cat. No.	MFG No.	Type	Finish	Flow Rate	Material
276196	621-CP	Institutional	Chrome	2.5 GPM	Brass

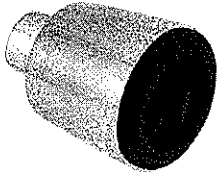

GERBER Showerhead

C.P. plastic. 2.5 GPM at 80 PSI with ball joint.



Cat. No.	MFG No.	Type	Finish	Flow Rate	Material
217521	49-197	Standard	Chrome	2.5 GPM	Non-Metallic

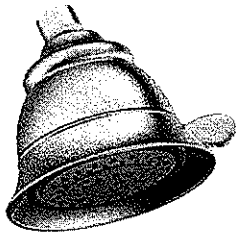

MOEN 4-Function Showerhead, #3838



- Fixed mount showerhead only
- Nonmetallic spray face and shell
- Brass swivel ball assembly
- 1/2" IPS connection
- 4 function massage, fine, full and combined (massage and full): rotate outer ring to select
- Designed to deliver 2.5 GPM (9.5 L/min) at 60 PSI
- Chrome finish

Cat. No.	MFG No.	Type	Finish	Flow Rate	Material
455406	3838	Massage	Chrome	2.5 GPM	Non-Metallic



COMMERCIAL AND INSTITUTIONAL MAINTENANCE, REPAIR AND OPERATIONS PRODUCTS

GENERAL PLUMBING SUPPLIES

BATH & SHOWER REPAIR AND REPLACEMENT

4 components
make up line
4

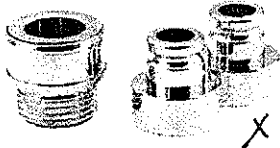

ALSONS Quick Disconnect/Connect Set

For hand held shower. Allows shower hose to be quickly detached for patient protection. Retrofits to all standard personal shower units. Chrome plated brass.

Cat. No.	MFG No.	Description	Finish	Material
327338	750BX	3-Piece Set	Chrome	Brass

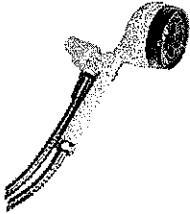

Water Massage Hand Held Shower Unit

Massage hand shower with nylon reinforced hose. Shower head adjusts from spray to pulsating massage action. White plastic with chrome trim. Includes shower arm bracket.

Cat. No.	Description	Size	Flow Rate	Length
154393	With 60" Hose	1/2" IPS	2.5 GPM	60"



Hand Held Personal Showerhead

Smart looking, lightweight head. Includes 59" chrome plated flexible hose, nylon bracket and mounting hardware. With handle shut-off feature. 2.5 GPM.

Cat. No.	MFG No.	Description	Flow Rate
154419	AS	With 59" Hose	2.5 GPM

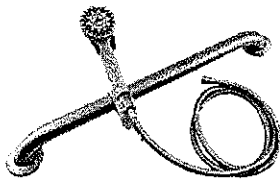

ALSONS Wall Grab Bar Hand Shower Unit

Features ADA wall bar with full spray hand shower with pause control. Includes adjustable slide mechanism, 60" Ultra-Flex® hose, 24" length grab bar. Chrome plated bar with white shower head. Mounting versatility. Can be securely mounted at any angle: Vertically, horizontally, 45°. In addition the mounting mechanism on the hand shower swivels ensuring an easy reach.



Mounts at Any Angle

Cat. No.	MFG No.	Size	Flow Rate	Length
327049	62001UFBX	1/2" IPS	2.5 GPM	60"



NEW!

T&S Hand Held Showerhead

Use T&S 1/2" male x 3/4"-14 adaptor (#080622) to hook up to a normal 1/2" IPS thread of other hoses.



Cat. No.	MFG No.
302281	SQ-95



COMMERCIAL AND INSTITUTIONAL MAINTENANCE, REPAIR AND OPERATIONS PRODUCTS

GENERAL PLUMBING SUPPLIES

BATH & SHOWER REPAIR AND REPLACEMENT

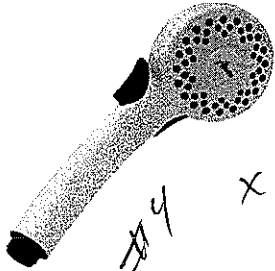
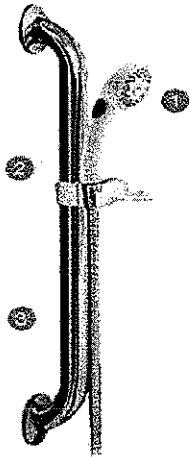

Replacement Parts for ALSONS Wall Grab Bar System Model Nos. 62001, 62002, 62003
 Complete unit available. Grab bar available separately on Special Order only.

Cat. No.	MFG No.	Description	Item	Color
029074	462PB	Hand Held Shower Head w/Volume Control	1	--
470437	6200BX	Wall Grab Bar Slide Mechanism	2	White
237313		Heavy-Duty Double Spiral Hose	3	--
327015		Ultra Flex Hose	3	--
327049		Wall Grab Bar System		--

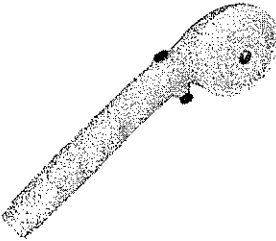

SEXAUER Replacement Heads for Personal Showers

Full spray hand held showerheads are made of heavy white plastic and are available with or without push button volume control. Includes 2.5 GPM water saver washer.

Cat. No.	Type	Size	Flow Rate	Material	Finish
701813	With Volume Control	1/2" IPS	2.5 GPM	Plastic	White
701821	Less Volume Control	1/2" IPS	2.5 GPM	Plastic	White

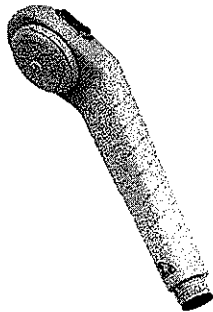

NEW!

Two-Function Hand Showerhead

Easy-grip push button for on and off. Economy with good performance.

Cat. No.	MFG No.
968644	103-42B

GENERAL PLUMBING SUPPLIES

BATH & SHOWER REPAIR AND REPLACEMENT

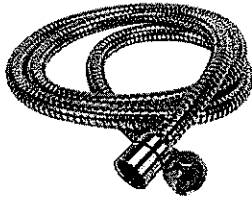

Heavy Duty Double Spiral, Chrome Plated Brass Metal Hoses

Extreme hose durability.

Cat. No.	Type	Size	Finish	Material	Length
237313	Double Spiral	1/2" IPS	Chrome	Brass	60"
237321	Double Spiral	1/2" IPS	Chrome	Brass	68"
237339		1/2" IPS	Chrome	Brass	79"

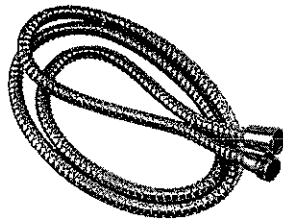

ALSONS Ultra-Flex® Shower Hoses

With white or black ribbon. One conical and one hex all-brass nuts.



Cat. No.	MFG No.	Size	Finish	Material	Length
327072	494C60PK	1/2" IPS	White Ribbon	Plastic	60"
327015	494C70		1/2" IPS	White Ribbon	70"
327080	49060BG	1/2" IPS	Black Ribbon	Plastic	60"
181446	49070BG		1/2" IPS	Black Ribbon	70"
327064	49084BG..	1/2" IPS	Black Ribbon	Plastic	84"

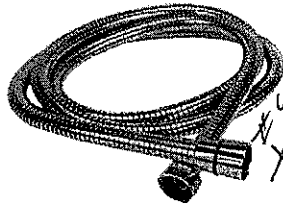

"BUNGY" Extensible Hand Shower Hose

Great quality stainless steel spiral hose stretches almost 1-1/2 times its length for an extended reach and greater safety. Eliminates broken hoses due to overstretching and pulling.

Cat. No.	Type	Size	Finish	Material	Length
968628	Stretch	1/2" IPS	Pol. St. Steel	Stainless Steel	59"
968636	Stretch	1/2" IPS	Pol. St. Steel	Stainless Steel	78"

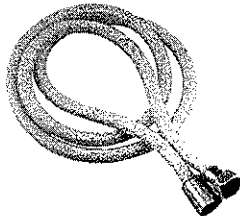

ALSONS Reinforced Vinyl Hoses

Heavy duty. One conical and one hex all-brass nuts. White.



Cat. No.	MFG No.	Type	Size	Finish	Material	Length
327098	495RV60	Reinforced	1/2" IPS	White	Vinyl	59"
326991	495RV70	Reinforced	1/2" IPS	White	Vinyl	69"
327007	495RV84BG	Reinforced	1/2" IPS	White	Vinyl	84"

NEW!

PROPLUS

Replacement Hoses for Personal Showers

- Heavy duty
- One conical and one hex all-brass nuts



Cat. No.	Finish	Material	Length
406241	Black & Chrome	PVC	70"
406242	White	Vinyl	59"
406243	White	Vinyl	69"
406244	White	Vinyl	60"

GENERAL PLUMBING SUPPLIES

BATH & SHOWER REPAIR AND REPLACEMENT

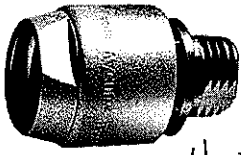

#4 X

ALSONS Deluxe Vacuum Breaker

Heavy duty C.P. brass inlet/shield. Functions in any position. Fail-safe. Atmospheric exposed type. For 1/2" IPS connections. Repair kit available.

Cat. No.	MFG No.	Description	Size	Finish	Material
049510	4900BG	Vacuum Breaker	1/2" IPS	Chrome	Brass
190637	49130BG	Repair Kit (Screen and Diaphragm)			

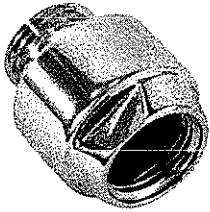

Deluxe Vacuum Breaker

- Brass Vacuum Breaker
- Heavy Duty
- Chrome
- Functions in any position
- For 1/2" IPS connections
- Checking on Fits Alsons 49030BG

Cat. No.	Description	Size	Finish	Material
406238	Vacuum Breaker	1/2" IPS	Chrome	Brass

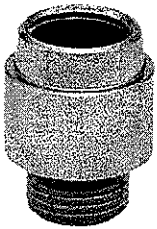

SEXAUER Hand Shower Vacuum Breaker

Heavy duty C.P. brass inlet/shield. Functions in any position. Fail-safe. Atmospheric exposed type. For 1/2" IPS connections.

Cat. No.	Description	Size	Finish	Material
700682	Vacuum Breaker	1/2" IPS	Chrome	Brass

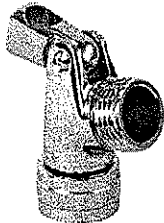

Hand Shower Swivel Connector

- For hand shower wall mounts
- Solid brass
- Chrome

Cat. No.	Finish
406237	Chrome



COMMERCIAL AND INSTITUTIONAL MAINTENANCE, REPAIR AND OPERATIONS PRODUCTS



State of West Virginia
 Department of Administration
 Purchasing Division
 2019 Washington Street East
 Post Office Box 50130
 Charleston, WV 25305-0130

Request for Quotation

RFQ NUMBER
 WSH11134

PAGE
 3

ADDRESS CORRESPONDENCE TO ATTENTION OF
 ROBERTA WAGNER
 304-558-0067

RFQ COPY
 TYPE NAME/ADDRESS HERE

Interline Brands, Inc.
 d/b/a Sexauer®

HEALTH AND HUMAN RESOURCES
 WILLIAM R. SHARPE JR. HOSPITAL
 CENTRAL RECEIVING
 936 SHARPE HOSPITAL ROAD
 WESTON, WV 26452 304-269-1210

DATE PRINTED	TERMS OF SALE	SHIP VIA	F.O.B.	FREIGHT TERMS
03/16/2011				

BID OPENING DATE: 04/14/2011 BID OPENING TIME 01:30PM

LINE	QUANTITY	UOP	CAT NO	ITEM NUMBER	UNIT PRICE	AMOUNT
<p>ALL POTENTIAL BIDDERS ARE REQUESTED TO ARRIVE PRIOR TO THE STARTING TIME FOR THE PRE-BID. BIDDERS WHO ARRIVE LATE, BUT PRIOR TO THE DISMISSAL OF THE TECHNICAL PORTION OF THE PRE-BID WILL BE PERMITTED TO SIGN IN. BIDDERS WHO ARRIVE AFTER CONCLUSION OF THE TECHNICAL PORTION OF THE PRE-BID, BUT DURING ANY SUBSEQUENT PART OF THE PRE-BID WILL NOT BE PERMITTED TO SIGN THE ATTENDANCE SHEET.</p> <p>CANCELLATION: THE DIRECTOR OF PURCHASING RESERVES THE RIGHT TO CANCEL THIS CONTRACT IMMEDIATELY UPON WRITTEN NOTICE TO THE VENDOR IF THE COMMODITIES AND/OR SERVICE SUPPLIED ARE OF AN INFERIOR QUALITY OR DO NOT CONFORM TO THE SPECIFICATIONS OF THE BID AND CONTRACT HEREIN.</p> <p>BANKRUPTCY: IN THE EVENT THE VENDOR/CONTRACTOR FILES FOR BANKRUPTCY PROTECTION, THE STATE MAY DEEM THE CONTRACT NULL AND VOID, AND TERMINATE SUCH CONTRACT WITHOUT FURTHER ORDER.</p> <p>INQUIRIES: WRITTEN QUESTIONS SHALL BE ACCEPTED THROUGH CLOSE OF BUSINESS ON 3/30/2011. QUESTIONS MAY BE SENT VIA USPS, FAX, COURIER OR E-MAIL. IN ORDER TO ASSURE NO VENDOR RECEIVES AN UNFAIR ADVANTAGE, NO SUBSTANTIVE QUESTIONS WILL BE ANSWERED ORALLY. IF POSSIBLE, E-MAIL QUESTIONS ARE PREFERRED. ADDRESS INQUIRIES TO:</p> <p>ROBERTA WAGNER DEPARTMENT OF ADMINISTRATION PURCHASING DIVISION 2019 WASHINGTON STREET, EAST CHARLESTON, WV 25311</p>						

SEE REVERSE SIDE FOR TERMS AND CONDITIONS

SIGNATURE <i>JMB</i> Fred M. Bravo	TELEPHONE 600-476-5830 x115015	DATE 4/4/11
TITLE V.P. of Field Sales	FEIN 22-2232306	ADDRESS CHANGES TO BE NOTED ABOVE

WHEN RESPONDING TO RFQ, INSERT NAME AND ADDRESS IN SPACE ABOVE LABELED 'VENDOR'



State of West Virginia
 Department of Administration
 Purchasing Division
 2019 Washington Street East
 Post Office Box 50130
 Charleston, WV 25305-0130

Request for Quotation

RFQ NUMBER
 WSH11134

PAGE
 4

ADDRESS CORRESPONDENCE TO ATTENTION OF
 ROBERTA WAGNER
 304-558-0067

RFQ COPY
 TYPE NAME/ADDRESS HERE

Interline Brands, Inc.
 d/b/a Sexauer®

HEALTH AND HUMAN RESOURCES
 WILLIAM R. SHARPE JR. HOSPITAL
 CENTRAL RECEIVING
 936 SHARPE HOSPITAL ROAD
 WESTON, WV
 26452 304-269-1210

DATE PRINTED	TERMS OF SALE	SHIP VIA	FOB	FREIGHT TERMS
03/16/2011				

BID OPENING DATE: 04/14/2011 BID OPENING TIME 01:30PM

LINE	QUANTITY	UOP	CAT NO	ITEM NUMBER	UNIT PRICE	AMOUNT
FAX: 304-558-4115 E-MAIL: ROBERTA.A.WAGNER@WV.GOV THE MODEL/BRAND/SPECIFICATIONS NAMED HEREIN ESTABLISH THE ACCEPTABLE LEVEL OF QUALITY ONLY AND ARE NOT INTENDED TO REFLECT A PREFERENCE OR FAVOR ANY PARTICULAR BRAND OR VENDOR. VENDORS WHO ARE BIDDING ALTERNATES SHOULD SO STATE AND INCLUDE PERTINENT LITERATURE AND SPECIFICATIONS. FAILURE TO PROVIDE INFORMATION FOR ANY ALTERNATES MAY BE GROUNDS FOR REJECTION OF THE BID. THE STATE RESERVES THE RIGHT TO WAIVE MINOR IRREGULARITIES IN BIDS OR SPECIFICATION IN ACCORDANCE WITH SECTION 148-1-4 (F) OF THE WEST VIRGINIA LEGISLATIVE RULES AND REGULATIONS. VENDOR PREFERENCE CERTIFICATE THIS TEAM EXHIBIT HAS BEEN REPLACED BY THE ONLINE VERSION WHICH IS AVAILABLE HERE: HTTP://WWW.STATE.WV.US/ADMIN/PURCHASE/VRC/VENPREF.PDF NOTICE A SIGNED BID MUST BE SUBMITTED TO: DEPARTMENT OF ADMINISTRATION PURCHASING DIVISION BUILDING 15 2019 WASHINGTON STREET, EAST CHARLESTON, WV 25305-0130						

SEE REVERSE SIDE FOR TERMS AND CONDITIONS

SIGNATURE <i>JMT</i>	TELEPHONE 800-476-5830 x115095	DATE 4/4/11
TITLE V.P. Field Sales	FEIN 22-2232386	ADDRESS CHANGES TO BE NOTED ABOVE

WHEN RESPONDING TO RFQ, INSERT NAME AND ADDRESS IN SPACE ABOVE LABELED 'VENDOR'



State of West Virginia
 Department of Administration
 Purchasing Division
 2019 Washington Street East
 Post Office Box 50130
 Charleston, WV 25305-0130

Request for Quotation

RFQ NUMBER
 WSH11134

PAGE
 5

ADDRESS CORRESPONDENCE TO ATTENTION OF
 ROBERTA WAGNER
 304-558-0067

RFQ COPY
 TYPE NAME/ADDRESS HERE

V
E
N
D
O
R

Interline Brands, Inc.
 d/b/a Sexauer®

S
H
I
P
T
O

HEALTH AND HUMAN RESOURCES
 WILLIAM R. SHARPE JR. HOSPITAL
 CENTRAL RECEIVING
 936 SHARPE HOSPITAL ROAD
 WESTON, WV
 26452 304-269-1210

DATE PRINTED	TERMS OF SALE	SHIP VIA	F.O.B.	FREIGHT TERMS
03/16/2011				

BID OPENING DATE: 04/14/2011 BID OPENING TIME 01:30PM

LINE	QUANTITY	UOP	CAT. NO.	ITEM NUMBER	UNIT PRICE	AMOUNT
PLEASE NOTE: A CONVENIENCE COPY WOULD BE APPRECIATED.						
THE BID SHOULD CONTAIN THIS INFORMATION ON THE FACE OF THE ENVELOPE OR THE BID MAY NOT BE CONSIDERED:						
SEALED BID						
BUYER:-----RW/FILE 22-----						
RFQ. NO.:-----WSH11134-----						
BID OPENING DATE:-----4/14/2011-----						
BID OPENING TIME:-----1:30 PM-----						
PLEASE PROVIDE A FAX NUMBER IN CASE IT IS NECESSARY TO CONTACT YOU REGARDING YOUR BID:						

CONTACT PERSON (PLEASE PRINT CLEARLY):						

0005	EA		910-65			
	43					
LIGATURE RESISTANT GRAB BARS PER ATTACHED SPECS				See breakdown 9346.39 next page and spec sheets behind price breakdown.		

SEE REVERSE SIDE FOR TERMS AND CONDITIONS

SIGNATURE *JM* TELEPHONE 800-476-5830 X115095 DATE 4/4/11

TITLE V.P. of Field Sales FEIN 22-2232386 ADDRESS CHANGES TO BE NOTED ABOVE

WHEN RESPONDING TO RFQ, INSERT NAME AND ADDRESS IN SPACE ABOVE LABELED 'VENDOR'

Line #5 Ligature Resistant Grab Bars Break Down

Line #5 Non stock from Bradley 20 business day lead time.

		<u>Unit price</u>	<u>extended amount</u>
#SA70-001 48"	15 pcs	\$180.64	\$2,709.60
#SA-70-001360 36"	13 pcs	\$67.77	\$881.01
#SA70-001 32"	1 pc	\$165.86	\$165.86
#Engr-Special 24" x 24" SA-70-059 In corner/specify right or left hand on po.	14 pcs	\$399.28	\$5,589.92
		TOTAL	\$9346.39



Search

Products

Service Parts

BIM - Revit

Government

Where to Buy

Home | Products | SafeCare | Accessories | Anti-Ligature Grab Bar

Anti-Ligature Grab Bar

Model SA70-001240

- 1-1/2" O.D.
- Front mounted
- Heavy duty stainless steel
- Stainless steel closure plate - anti-ligature

Stainless steel grab bar with welded plate to fill cavity between bar and wall.

[Additional Security Accessories](#)

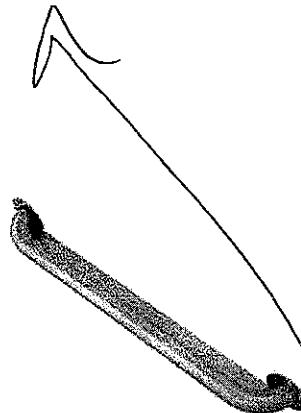

SA70-001240

Anti-Ligature Grab Bar

Technical Data

[SA70 Grab Bars PDF](#)

[SA70 Grab Bars -español PDF](#)

[SA70 Grab Bars -français PDF](#)

BIM Files

[Available for Download \(Revit MEP\)](#)

SafeCare

#5

Warranty

Bradley Fixtures Corporation warrants to commercial and institutional purchasers only, each new Bradley unit to be free from defects in material and workmanship under normal use and service upon the following terms and conditions:

This warranty is limited to replacing or repairing, at our option, transportation charges prepaid by the purchaser, any Bradley unit or part thereof, which our inspection shall show to have been defective within the limitations of this warranty.

The period during which Bradley units are warranted measured from the date of installation is as follows: Evero™ material warranted for fifteen years. ndite™ power management module and photovoltaic cells warranted for five years. Terreon® material warranted for ten years. All other components warranted for one year.

This warranty does not cover installation or any other labor charges and does not apply to any units, which have been damaged by accident, abuse, improper installation, improper maintenance, or altered in any way.

The replacement or repair of defective plumbing fixture units as stated in this warranty shall constitute the sole remedy of the purchaser and the sole liability of Bradley Fixtures Corporation under this warranty. **BRADLEY FIXTURES CORPORATION SHALL NOT UNDER ANY CIRCUMSTANCES BE LIABLE FOR INCIDENTAL, CONSEQUENTIAL OR INDIRECT DAMAGES CAUSED BY DEFECTS IN BRADLEY PLUMBING FIXTURE UNITS OR ANY DELAY IN THE REPAIR OR REPLACEMENT THEREOF.**

This warranty extends only to commercial and institutional purchasers and does not extend to any others, including consumer customers of commercial and institutional purchasers.

THIS WARRANTY IS IN LIEU OF ALL OTHER WARRANTIES, EXPRESSED OR IMPLIED, INCLUDING ANY IMPLIED WARRANTY OF MERCHANTABILITY OR FITNESS FOR A PARTICULAR PURPOSE OR OTHERWISE.

Revised: January 15, 2008

Grab bar:

- Model SA70-001180 (18" long)
- Model SA70-001240 (24" long)
- Model SA70-001360 (36" long) **Bradex®**
- Model SA70-001420 (42" long) **Bradex®**
- Model SA70-002600 (60" long)

Product Materials

FLANGES: 3/4" dia. 11 gauge stainless steel, with exposed surfaces in architectural satin finish.

TUBING: 1 1/2" O.D. 18 gauge stainless steel, seamless construction with exposed surfaces in architectural satin finish. Bent ends of tubing pass through the flanges and are welded into a single structural unit for maximum strength. Intermediate supports are contour cut and joined by welding to form an integral part of the grab bar. All welds ground and polished to blend. Mandrel bending process maintains uniform bar diameter. Return provides 1 1/2" standard safety clearance between wall and bar.

CLOSURE PLATE: 11 gauge stainless steel.

Strength

When properly mounted, all Bradley heavy duty grab bar systems meet or exceed the requirements of ANSI Standard A117.1, the ADA and ABA Accessibility Guidelines for Buildings and Facilities (ADAAG) and the Uniform Federal Accessibility Standard (UFAS).

Installation

Verify all rough-in dimensions prior to installation. Use bar as template to locate mounting holes. Unit supplied with torx-head screws.

Optional Features

Feature	Suffix
<input type="checkbox"/> Safety-grip finish	-2

Guide Specification

Security grab bar shall be fabricated of 1 1/2" O.D. satin finish stainless steel with exposed mounting flanges and 11 gauge stainless steel closure plate in sizes and configurations as indicated. Furnished with torx-head mounting screws.

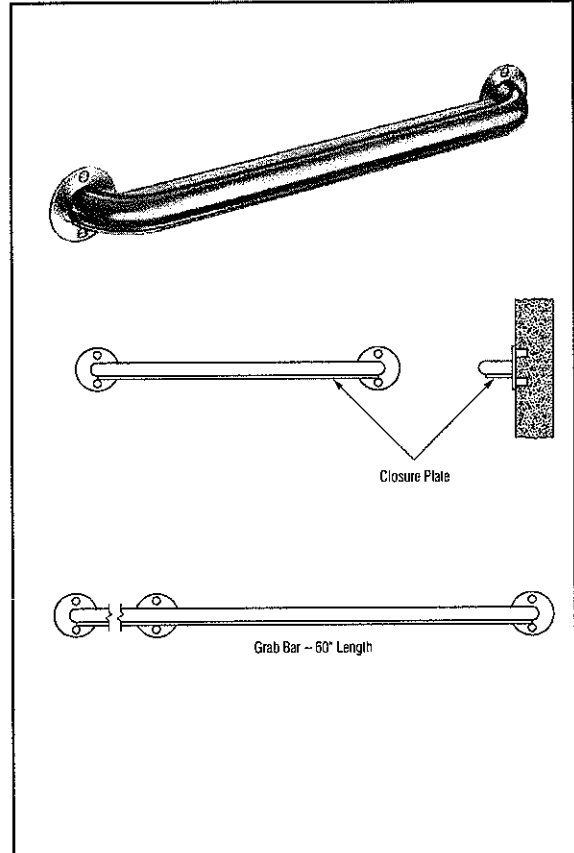

Washroom Accessories
Document No. 9310

Page 1 of 1

This information is subject to change without notice.

Always consult local and national codes for proper installation guidelines. Conformity and compliance to local and national codes is the responsibility of the installer.

4-1-2010

Orders composed of products indicated as **Bradex®** will be available to ship in one week after receipt of order at the factory. There is no pricing penalty for this service from Bradley.

© 2010 Bradley Corporation
P.O. Box 309, Menomonee Falls, WI 53052-0309
Phone: 800.BRADLEY (800.272.3539) Fax: 262.253.4161
bradleycorp.com

003

Standard length 48", 52" or 54" with center post; only one end return.

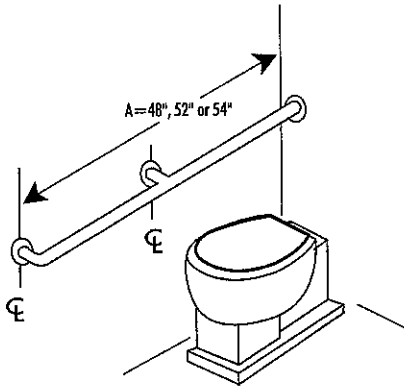

012

Confirm clearance between fixture or plumbing and grab bar in individual applications.

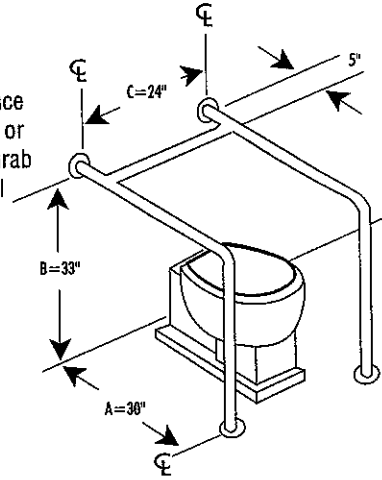

036

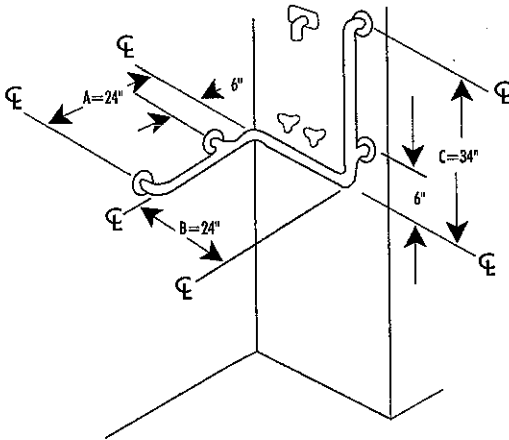

037

Opposite 036.

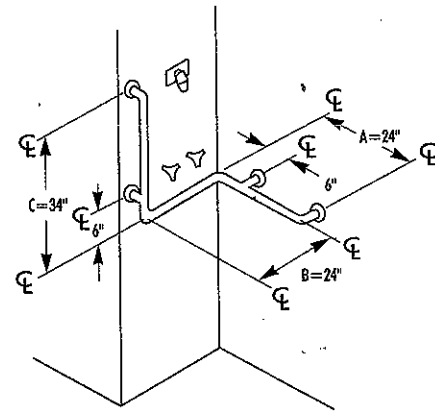

054

30" x 33"
Note: 1" not available for this application.

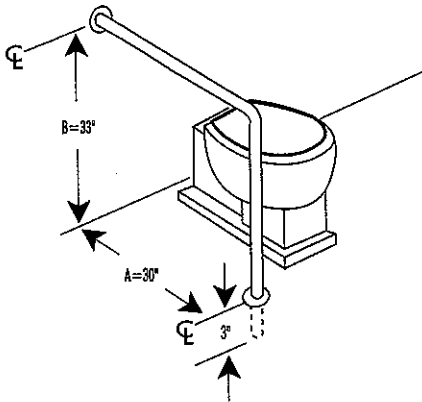

059

For special sizes, specify 059 modified ___" x ___". B side will have stand off.

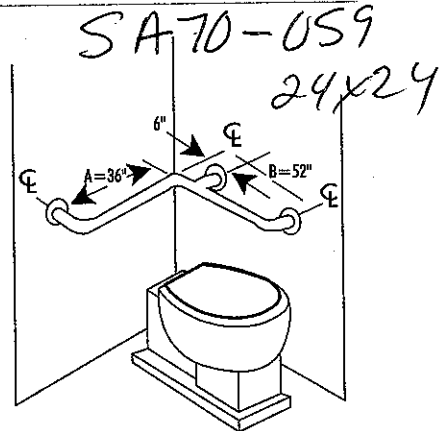

060

Specify ___" x ___" x ___".
(Note: standard dimensions are 36" x 60" x 36".)
This configuration ships in two pieces which are joined at the coupling.
This configuration is UPS shippable.

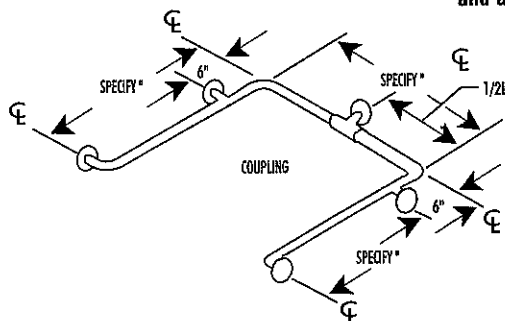

For complete list of railings, mounting kits and anchoring devices, see technical data catalog.



State of West Virginia
 Department of Administration
 Purchasing Division
 2019 Washington Street East
 Post Office Box 50130
 Charleston, WV 25305-0130

Request for Quotation

RFQ NUMBER
 WSH11134

PAGE
 6

ADDRESS CORRESPONDENCE TO ATTENTION OF
 ROBERTA WAGNER
 304-558-0067

RFQ COPY
 TYPE NAME/ADDRESS HERE

Interline Brands, Inc.
 d/b/a Sexauer®

HEALTH AND HUMAN RESOURCES
 WILLIAM R. SHARPE JR. HOSPITAL
 CENTRAL RECEIVING
 936 SHARPE HOSPITAL ROAD
 WESTON, WV
 26452 304-269-1210

DATE PRINTED	TERMS OF SALE	SHIP VIA	FOB	FREIGHT TERMS
03/16/2011				

BID OPENING DATE: 04/14/2011 BID OPENING TIME 01:30PM

LINE	QUANTITY	UOP	CAT. NO.	ITEM NUMBER	UNIT PRICE	AMOUNT
0006	16	EA		910-65	NO BID	—
REPLACEMENT DOORS PER ATTACHED SPECIFICATIONS						
0007	499	EA		910-65	NO BID	—
ANTI-LIGATURE LOCKSETS PER ATTACHED SPECIFICATIONS						
***** THIS IS THE END OF RFQ WSH11134 ***** TOTAL:						<u>\$17,920.87</u>

SEE REVERSE SIDE FOR TERMS AND CONDITIONS

SIGNATURE *JM* TELEPHONE 800-476-5830 X115095 DATE 4/4/11
 TITLE V.P. of Field Sales FEN 22-2232386 ADDRESS CHANGES TO BE NOTED ABOVE

WHEN RESPONDING TO RFQ, INSERT NAME AND ADDRESS IN SPACE ABOVE LABELED 'VENDOR'

WV-38A (Rev. 01/01/07)

STATE OF WEST VIRGINIA

PURCHASE CONTINUATION SHEET

Vendor:

Buyer:	Page:	Requisition or P.O. No.:
		WSH11134
Spending Unit:		
William R. Sharpe Jr. Hospital		

A TOUR OF THE FACILITY WILL FOLLOW THE TECHNICAL PORTION OF THIS MEETING. THIS WILL ALLOW POTENTIAL BIDDERS TO TAKE ANY MEASUREMENTS OR ASK ANY ADDITIONAL QUESTIONS ON THE LISTED PROJECTS.

Vendor to provide bids on the following items:

Project #1 Flush Valve Covers

Vendor must provide 150 fabricated 16 gauge stainless steel #3 toilet piping covers. These covers must enclose the entire piping system and allow for a push button flush valve. They must also be suicide proof. Also must be made in a manner that will allow for removal to do repairs to piping.

Project #2 - Flush Valves

Vendor must provide 125 flush valves for a Sloan C9A (or equal), 2 3/4 wall thickness, LDM. This must be compatible with the existing flush valves.

Project #3 - Handicap Showers

Vendor must provide 18 ligature resistant shower heads, chrome plated solid cast bronze, 2.5 gpm max flow rate, adjustable spray angle (20-30 degree). Must meet American Society of Mechanical Engineers (ASME) A112.18.1M and CSA B125. 1/2 inch female National Pipe Thread (NPT) inlet. Stainless steel, tamper-proof screws.

Vendor must provide 18 quick connect hand held shower heads. 60 inch long nominal (82 inch extended) stainless steel spiraled over rubber liner. Spray head must include push button, built in back flow preventer made from engineering grade plastic. Must meet American Society of Mechanical Engineers (ASME) A112.18.1M and CSA B125. 1/2 inch female National Pipe Thread (NPT) inlet. Stainless steel, tamper-proof screws.

Vendor must provide 43 ligature resistant grab bars. Size of grab bars shall be 1.655 inch diameter bar, 3.453 inch max distance from wall, and variable lengths. Made from 6063 T6 aluminum. Finish must be powder coated with a clear protective top coat. Fasteners shall be stainless steel temper proof.

Project #4 - Replacement Doors

	Left hung (LH)	Right hung (RH) (in inches)
C104	LH 35 1/8 X 85 1/4	
C143	LH 35 5/8 X 85 3/4	
C158 C1 TO OFFICE POD	LH 35 3/4 X 85 1/8	
C135 C2 ISOLATION ROOM	LH 35 1/8 X 85 1/4	
C2 WING C135	LH 35 5/8 X 85 1/2	
G1 G104	LH 35 5/8 X 85 5/8	
G1 TO OFFICE POD	LH 35 3/4 X 85 1/4	
G136 ISOLATION ROOM	LH 35 5/8 X 85 3/8	
CONNECTION DOOR G1 / G2	RH 45 7/8 X 85 3/4	
E1 E126 ISOLATION TO ANTI ROOM	LH 45 5/8 X 85 3/16	
E1 E150 OFFICE POD	LH 35 3/4 X 85 1/8	
E1 ENTRY TO COURTYARD	LH 41 1/8 X 83 3/4	
E2 ENTRANCE TO POD	LH 35 3/4 X 85 5/8	
E2 ENTRY TO COURTYARD	LH 41 1/4 X 83 3/4	
E167 E2 CONSULTATION ROOM	RH 35 5/8 X 85 3/16	
G145	LH 35 3/4 X 85 1/8	

WV-32A (Rev. 01/01/07)

**STATE OF WEST VIRGINIA
PURCHASE CONTINUATION SHEET**

Buyer:	Phase:	Requisition or P.O. No.:
		WSH11134

Vendor: _____

Spending Unit:
William R. Sharpe Jr. Hospital

The doors listed above must be replaced with fire rated doors, all doors must be made of aluminum in accordance with all National Fire Protection Association (NFPA) codes. This can be found online at www.nfpa.org. Any and all hardware needed for installation shall be included. All doors must have 1/4" wire mesh safety glass 18"X32". They must also fit the existing frames measured above and must accept the mortise lock sets that are the same as or equal to lock sets we currently use. (Current lockset numbers - 45H7G3J-826 RH/LH and 45H7C16R-626 RH/LH).

Project #5 Anti Ligature Locksets

1. Vendor must provide anti ligature locksets as manufactured by Stanley Security Solutions where specified, or equal.
2. All fasteners shall be "security - tip" fasteners (pin-in head torx or similar) with no exposed fasteners on the secure side of the door.
3. Conical shank shall be through-bolted. "Roses" or independent exposed bases, with a visible separation between the conical shank and the rose are not permitted.
4. Lever projection off the door shall not exceed two inches.
5. Levers, exposed hardware and lock body shall be of stainless steel construction.
6. Internal lever stops shall be stainless steel.
7. All door levers must meet all Americans with Disabilities Act (ADA) requirements.
8. Any and all hardware needed for installation shall be included.
9. All exposed screws must be stainless steel and tamper proof.

The following list is door type and number of doors needing Anti Ligature Locksets

ENTRY DOOR SPSL ML R 16F 630 LH SH	49
ENTRY DOOR SPSL ML R 16F 630 RH SH	44
ENTRY DOOR SPSL ML R 16F 630 LHR SH	1
ENTRY DOOR SPSL ML R 16F 630 RHR SH	2
BATHROOM SPSL ML LT 16F630 LH SH	37
BATHROOM SPSL ML LT 16F630 RH SH	30
BATHROOM SPSL ML LT 16F630 LHR SH	12
BATHROOM SPSL ML LT 16F630 RHR SH	7
STOREROOM SPSL MLD 16F 630 LH SH	29
STOREROOM SPSL MLD 16F 630 RH SH	29
STOREROOM SPSL MLD 16F 630 LHR SH	79
STOREROOM SPSL MLD 16F 630 RHR SH	88
INTRUDER SPSL ML INL 16F 630 LH SH	2
ASYLUM SPSL ML W2 16F 630 LHR SH	1
ASYLUM SPSL ML W2 16F 630 RHR SH	1
ASYLUM SPSL ML W4 16F 630 LHR SH	2
ASYLUM SPSL ML W4 16F 630 RHR SH	4
DUMMY TRIM SPSL DT 630	9
DUMMY TRIM SPSL DTX 630	17
TAPERED COLLAR 626	33
4" x 16" 626 PUSH PLATE	26
4" x 26" 626 PUSH PLATE	2

****Entire order must be delivered on or before May 1, 2011. Partial orders will be accepted, but vendor will not be paid until entire order has been shipped, received and accepted by facility. ITEMS WILL BE INSTALLED BY DHHR STAFF. THIS WILL BE FOR MATERIALS ONLY.**

WV-38 (Rev. 01/01/07)

STATE OF WEST VIRGINIA

PURCHASE CONTINUATION SHEET

Vendor: _____ P.O. Date: _____

Requisition/P.O. No.:
W8H11134

File: _____ Acct. No.: _____

Spending Unit:
William R. Sherpe Jr. Hospital

Item No.	Quantity	Description	Unit Price	Amount
<p>Project Cost Sheet Please see previous pages for specific requirements</p>				
	150	Project #1 - Flush Valve Covers Flush Valve Covers	\$ <u>NO BID</u>	
	125	Project #2 - Flush Valves Flush valves Sloan # 0303036	\$ <u>50.58</u>	\$ 6322.50
	18	Project #3 - Handicap Showers Ligature resistant shower heads	\$ <u>See</u>	\$ 11,598.37
	18	Quick connect hand held shower heads	breakdown next page	
	43	Ligature resistant grab bars		
	16	Project #4 - Replacement Doors Replacement doors	\$ <u>NO BID</u>	
	499	Project #5 - Anti-Ligature Locksets Anti-ligature locksets	\$ <u>NO BID</u>	
			TOTAL	\$ <u>17,920.87</u>
<p>Evaluation will be made to vendor(s) meeting specifications with lowest bid per project.</p> <p>This is a multiple award to be awarded per lowest bid meeting specifications per project.</p>				

State of West Virginia Purchase Continuation Sheet

RFQ #WSH11134

			<u>Unit Price</u>	<u>extended amount</u>
Project#3	Sx#276196	18 pcs	\$71.67	\$1,290.06
	Sx#029074	18 pcs	\$8.74	\$157.32
	Sx#327338	18 pcs	\$27.05	\$486.90
	Sx#968628	18 pcs	\$10.67	\$192.06
	Sx#49510	18 pcs	\$6.98	\$125.64
	SA70-001 48"	15 pcs	\$180.64	\$2,709.60
	SA-70-001360 36"	13 pcs	\$67.77	\$881.01
	SA-70-001 32"	1 pc	\$165.86	\$165.86
	SA-70-059 24x24	14 pcs	\$399.28	\$5589.92

Engr-Special 24" x 24" must specify left or right hand when ordering.

RFQ No. WS # 11134

STATE OF WEST VIRGINIA
Purchasing Division

PURCHASING AFFIDAVIT

West Virginia Code §5A-3-10a states: No contract or renewal of any contract may be awarded by the state or any of its political subdivisions to any vendor or prospective vendor when the vendor or prospective vendor or a related party to the vendor or prospective vendor is a debtor and the debt owed is an amount greater than one thousand dollars in the aggregate.

DEFINITIONS:

"Debt" means any assessment, premium, penalty, fine, tax or other amount of money owed to the state or any of its political subdivisions because of a judgment, fine, permit violation, license assessment, defaulted workers' compensation premium, penalty or other assessment presently delinquent or due and required to be paid to the state or any of its political subdivisions, including any interest or additional penalties accrued thereon.

"Debtor" means any individual, corporation, partnership, association, limited liability company or any other form or business association owing a debt to the state or any of its political subdivisions. "Political subdivision" means any county commission; municipality; county board of education; any instrumentality established by a county or municipality; any separate corporation or instrumentality established by one or more counties or municipalities, as permitted by law; or any public body charged by law with the performance of a government function or whose jurisdiction is coextensive with one or more counties or municipalities. "Related party" means a party, whether an individual, corporation, partnership, association, limited liability company or any other form or business association or other entity whatsoever, related to any vendor by blood, marriage, ownership or contract through which the party has a relationship of ownership or other interest with the vendor so that the party will actually or by effect receive or control a portion of the benefit, profit or other consideration from performance of a vendor contract with the party receiving an amount that meets or exceed five percent of the total contract amount.

EXCEPTION: The prohibition of this section does not apply where a vendor has contested any tax administered pursuant to chapter eleven of this code, workers' compensation premium, permit fee or environmental fee or assessment and the matter has not become final or where the vendor has entered into a payment plan or agreement and the vendor is not in default of any of the provisions of such plan or agreement.

Under penalty of law for false swearing (*West Virginia Code §61-5-3*), it is hereby certified that the vendor affirms and acknowledges the information in this affidavit and is in compliance with the requirements as stated.

WITNESS THE FOLLOWING SIGNATURE

Vendor's Name: Interline Brands, Inc. db/a Sexaver

Authorized Signature: [Signature] Date: 4/12/11

State of FL

County of Duval, to-wit:

Taken, subscribed, and sworn to before me this 12 day of April, 2011.

My Commission expires 12-22, 2013.

AFFIX SEAL HERE

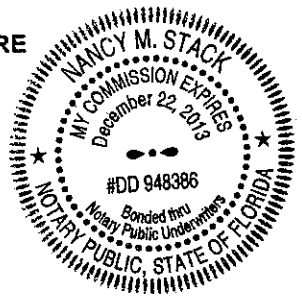

NOTARY PUBLIC

[Signature]

State of West Virginia

VENDOR PREFERENCE CERTIFICATE

Certification and application* is hereby made for Preference in accordance with West Virginia Code, §5A-3-37. (Does not apply to construction contracts). West Virginia Code, §5A-3-37, provides an opportunity for qualifying vendors to request (at the time of bid) preference for their residency status. Such preference is an evaluation method only and will be applied only to the cost bid in accordance with the West Virginia Code. This certificate for application is to be used to request such preference. The Purchasing Division will make the determination of the Resident Vendor Preference, if applicable.

1. Application is made for 2.5% resident vendor preference for the reason checked:

- Bidder is an individual resident vendor and has resided continuously in West Virginia for four (4) years immediately preceding the date of this certification; or, Bidder is a partnership, association or corporation resident vendor and has maintained its headquarters or principal place of business continuously in West Virginia for four (4) years immediately preceding the date of this certification; or 80% of the ownership interest of Bidder is held by another individual, partnership, association or corporation resident vendor who has maintained its headquarters or principal place of business continuously in West Virginia for four (4) years immediately preceding the date of this certification; or, Bidder is a nonresident vendor which has an affiliate or subsidiary which employs a minimum of one hundred state residents and which has maintained its headquarters or principal place of business within West Virginia continuously for the four (4) years immediately preceding the date of this certification; or,

2. Application is made for 2.5% resident vendor preference for the reason checked:

Bidder is a resident vendor who certifies that, during the life of the contract, on average at least 75% of the employees working on the project being bid are residents of West Virginia who have resided in the state continuously for the two years immediately preceding submission of this bid; or,

3. Application is made for 2.5% resident vendor preference for the reason checked:

Bidder is a nonresident vendor employing a minimum of one hundred state residents or is a nonresident vendor with an affiliate or subsidiary which maintains its headquarters or principal place of business within West Virginia employing a minimum of one hundred state residents who certifies that, during the life of the contract, on average at least 75% of the employees or Bidder's affiliate's or subsidiary's employees are residents of West Virginia who have resided in the state continuously for the two years immediately preceding submission of this bid; or,

4. Application is made for 5% resident vendor preference for the reason checked:

Bidder meets either the requirement of both subdivisions (1) and (2) or subdivision (1) and (3) as stated above; or,

5. Application is made for 3.5% resident vendor preference who is a veteran for the reason checked:

Bidder is an individual resident vendor who is a veteran of the United States armed forces, the reserves or the National Guard and has resided in West Virginia continuously for the four years immediately preceding the date on which the bid is submitted; or,

6. Application is made for 3.5% resident vendor preference who is a veteran for the reason checked:

Bidder is a resident vendor who is a veteran of the United States armed forces, the reserves or the National Guard, if, for purposes of producing or distributing the commodities or completing the project which is the subject of the vendor's bid and continuously over the entire term of the project, on average at least seventy-five percent of the vendor's employees are residents of West Virginia who have resided in the state continuously for the two immediately preceding years.

Bidder understands if the Secretary of Revenue determines that a Bidder receiving preference has failed to continue to meet the requirements for such preference, the Secretary may order the Director of Purchasing to: (a) reject the bid; or (b) assess a penalty against such Bidder in an amount not to exceed 5% of the bid amount and that such penalty will be paid to the contracting agency or deducted from any unpaid balance on the contract or purchase order.

By submission of this certificate, Bidder agrees to disclose any reasonably requested information to the Purchasing Division and authorizes the Department of Revenue to disclose to the Director of Purchasing appropriate information verifying that Bidder has paid the required business taxes, provided that such information does not contain the amounts of taxes paid nor any other information deemed by the Tax Commissioner to be confidential.

Under penalty of law for false swearing (West Virginia Code, §61-5-3), Bidder hereby certifies that this certificate is true and accurate in all respects; and that if a contract is issued to Bidder and if anything contained within this certificate changes during the term of the contract, Bidder will notify the Purchasing Division in writing immediately.

* Bidder: Interline Brands, Inc. d/b/a Sexauer® Signed: JMT Title: V.P. of Field Sales Date: 4/4/11

*Check any combination of preference consideration(s) indicated above, which you are entitled to receive.

* our Corporate office is located in Jacksonville FL