



State of West Virginia
 Department of Administration
 Purchasing Division
 2019 Washington Street East
 Post Office Box 50130
 Charleston, WV 25305-0130

Request for Quotation

RFQ NUMBER
 MMB11028

PAGE
 3

ADDRESS CORRESPONDENCE TO ATTENTION OF
 ROBERTA WAGNER
 304-558-0067

VENDOR

RFQ COPY
 TYPE NAME/ADDRESS HERE

Lungs Security Camera Systems LLC
 102 3rd ST SE
 Charleston WV 25304

SHIP TO

HEALTH AND HUMAN RESOURCES
 MILDRED MITCHELL-BATEMAN
 HOSPITAL
 530 NORWAY AVENUE
 HUNTINGTON, WV
 25705 304-525-7801

DATE PRINTED	TERMS OF SALE	SHIP VIA	F.O.B.	FREIGHT TERMS
11/10/2010				

BID OPENING DATE: 12/23/2010 BID OPENING TIME 01:30PM

LINE	QUANTITY	UOP	CAT NO.	ITEM NUMBER	UNIT PRICE	AMOUNT
0009	1	EA		936-73		
				<i>See attached addendum #1</i>		
				OPERATIONAL INTERFACE		
0010	1	EA		936-73		
				ACCESS CONTROL SYSTEM SOFTWARE		
0011	1	EA		936-73		
				SOFTWARE FOR PREPARATION OF ACCESS CARDS FOR STAFF		
0012	1	EA		936-73		
				INSTALLATION COST OF HARDWARE AND SOFTWARE.		
0013	1	EA		936-73		
				BATTERY BACKUP		

RECEIVED
 2011 JAN -6 PM 1:09

SEE REVERSE SIDE FOR TERMS AND CONDITIONS

SIGNATURE: *[Signature]* TELEPHONE: 304-925-0338 DATE: 1-6-11

TITLE: Owner FEIN: 20-3881880-001 ADDRESS CHANGES TO BE NOTED ABOVE

WHEN RESPONDING TO RFQ, INSERT NAME AND ADDRESS IN SPACE ABOVE LABELED 'VENDOR'



State of West Virginia
 Department of Administration
 Purchasing Division
 2019 Washington Street East
 Post Office Box 50130
 Charleston, WV 25305-0130

**Request for
 Quotation**

RFQ NUMBER
 MMB11028

PAGE
 4

ADDRESS CORRESPONDENCE TO ATTENTION OF
 ROBERTA WAGNER
 304-558-0067

VENDOR

RFQ COPY
 TYPE NAME/ADDRESS HERE

SHIP TO

HEALTH AND HUMAN RESOURCES
 MILDRED MITCHELL-BATEMAN
 HOSPITAL
 530 NORWAY AVENUE
 HUNTINGTON, WV
 25705 304-525-7801

DATE PRINTED	TERMS OF SALE	SHIP VIA	FOB	FREIGHT TERMS
11/10/2010				

BID OPENING DATE: 12/23/2010 BID OPENING TIME 01:30PM

LINE	QUANTITY	UOP	CAT NO.	ITEM NUMBER	UNIT PRICE	AMOUNT
0014	2	EA		936-73		
TWO (2) YEAR WARRANTY FOR SOFTWARE, HARDWARE, LABOR AND PARTS.						
0015	3	EA		936-73		
TRAINING COST						
0016	1,000	EA		936-73		
ACCESS CARD SUPPLIES						
<p>MILDRED MITCHELL-BATEMAN HOSPITAL IS SEEKING BIDS FOR THE PURCHASING AND INSTALLATION OF AN ACCESS CONTROL SYSTEM DESIGNED TO INCLUDE READER IN/READER OUT CAPABILITIES AT THIRTY-ONE (31) EXTERIOR DOOR (MAPS ATTACHED) AT THE FACILITY, PER THE ATTACHED SPECIFICATIONS.</p> <p>INQUIRIES: WRITTEN QUESTIONS SHALL BE ACCEPTED THROUGH CLOSE OF BUSINESS ON 12/7/2010. QUESTIONS MAY BE</p>						

SEE REVERSE SIDE FOR TERMS AND CONDITIONS

SIGNATURE	TELEPHONE	DATE
TITLE	FEIN	ADDRESS CHANGES TO BE NOTED ABOVE

WHEN RESPONDING TO RFQ, INSERT NAME AND ADDRESS IN SPACE ABOVE LABELED 'VENDOR'



State of West Virginia
 Department of Administration
 Purchasing Division
 2019 Washington Street East
 Post Office Box 50130
 Charleston, WV 25305-0130

Request for Quotation

RFQ NUMBER:
 MMB11028

PAGE:
 5

ADDRESS CORRESPONDENCE TO ATTENTION OF:
 ROBERTA WAGNER
 304-558-0067

VENDOR

RFQ COPY
 TYPE NAME/ADDRESS HERE

VENDOR

HEALTH AND HUMAN RESOURCES
 MILDRED MITCHELL-BATEMAN
 HOSPITAL
 1530 NORWAY AVENUE
 HUNTINGTON, WV
 25705 304-525-7801

DATE PRINTED	TERMS OF SALE	SHIP VIA	FOB	FREIGHT TERMS
11/10/2010				

BID OPENING DATE: 12/23/2010 BID OPENING TIME 01:30PM

LINE	QUANTITY	UOP	CAT NO	ITEM NUMBER	UNIT PRICE	AMOUNT
<p>SENT VIA USPS, FAX, COURIER OR E-MAIL. IN ORDER TO ASSURE NO VENDOR RECEIVES AN UNFAIR ADVANTAGE, NO SUBSTANTIVE QUESTIONS WILL BE ANSWERED ORALLY. IF POSSIBLE, E-MAIL QUESTIONS ARE PREFERRED. ADDRESS INQUIRIES TO:</p> <p>ROBERTA WAGNER DEPARTMENT OF ADMINISTRATION PURCHASING DIVISION 2019 WASHINGTON STREET, EAST CHARLESTON, WV 25311</p> <p>FAX: 304-558-4115 E-MAIL: ROBERTA.A.WAGNER@WV.GOV.</p> <p>MANDATORY PRE-BID</p> <p>A MANDATORY PRE-BID WILL BE HELD ON 12/6/2010 AT 11:00 AM IN THE ADM CONF. RM AT MILDRED MITCHELL-BATEMAN. ALL INTERESTED PARTIES ARE REQUIRED TO ATTEND THIS MEETING. FAILURE TO ATTEND THE MANDATORY PRE-BID SHALL RESULT I DISQUALIFICATION OF THE BID. NO ONE PERSON MAY REPRESENT MORE THAN ONE BIDDER.</p> <p>AN ATTENDANCE SHEET WILL BE MADE AVAILABLE FOR ALL POTENTIAL BIDDERS TO COMPLETE. THIS WILL SERVE AS THE OFFICIAL DOCUMENT VERIFYING ATTENDANCE AT THE MANDATOR PRE-BID. FAILURE TO PROVIDE YOUR COMPANY AND REPRESENTATIVE NAME ON THE ATTENDANCE SHEET WILL RESULT IN DISQUALIFICATION OF THE BID. THE STATE WILL NOT ACCEPT ANY OTHER DOCUMENTATION TO VERIFY ATTENDANCE. THE BIDDER IS RESPONSIBLE FOR ENSURING THEY HAVE COMPLETED THE INFORMATION REQUIRED ON THE ATTENDANCE</p>						

SEE REVERSE SIDE FOR TERMS AND CONDITIONS

SIGNATURE	TELEPHONE	DATE
TITLE	FEIN	ADDRESS CHANGES TO BE NOTED ABOVE

WHEN RESPONDING TO RFQ, INSERT NAME AND ADDRESS IN SPACE ABOVE LABELED 'VENDOR'



State of West Virginia
 Department of Administration
 Purchasing Division
 2019 Washington Street East
 Post Office Box 50130
 Charleston, WV 25305-0130

Request for Quotation

RFO NUMBER
 MMB11028

PAGE
 6

ADDRESS CORRESPONDENCE TO ATTENTION OF:
 ROBERTA WAGNER
 304-558-0067

VENDOR

RFQ COPY
 TYPE NAME/ADDRESS HERE

VENDOR

HEALTH AND HUMAN RESOURCES
 MILDRED MITCHELL-BATEMAN
 HOSPITAL
 530 NORWAY AVENUE
 HUNTINGTON, WV
 25705 304-525-7801

DATE PRINTED	TERMS OF SALE	SHIP VIA	F.O.B.	FREIGHT TERMS
11/10/2010				

BID OPENING DATE: 12/23/2010 BID OPENING TIME 01:30PM

LINE	QUANTITY	UOP	CAT NO.	ITEM NUMBER	UNIT PRICE	AMOUNT
<p>SHEET. THE PURCHASING DIVISION AND THE STATE AGENCY WILL NOT ASSUME ANY RESPONSIBILITY FOR A BIDDER-S FAILURE TO COMPLETE THE PRE-BID ATTENDANCE SHEET. IN ADDITION, WE REQUEST THAT ALL POTENTIAL BIDDERS INCLUDE THEIR E-MAIL ADDRESS AND FAX NUMBER.</p> <p>ALL POTENTIAL BIDDERS ARE REQUESTED TO ARRIVE PRIOR TO THE STARTING TIME FOR THE PRE-BID. BIDDERS WHO ARRIVE LATE, BUT PRIOR TO THE DISMISSAL OF THE TECHNICAL PORTION OF THE PRE-BID WILL BE PERMITTED TO SIGN IN. BIDDERS WHO ARRIVE AFTER CONCLUSION OF THE TECHNICAL PORTION OF THE PRE-BID, BUT DURING ANY SUBSEQUENT PART OF THE PRE-BID WILL NOT BE PERMITTED TO SIGN THE ATTENDANCE SHEET.</p> <p>THE MODEL/BRAND/SPECIFICATIONS NAMED HEREIN ESTABLISH THE ACCEPTABLE LEVEL OF QUALITY ONLY AND ARE NOT INTENDED TO REFLECT A PREFERENCE OR FAVOR ANY PARTICULAR BRAND OR VENDOR. VENDORS WHO ARE BIDDING ALTERNATES SHOULD SO STATE AND INCLUDE PERTINENT LITERATURE AND SPECIFICATIONS. FAILURE TO PROVIDE INFORMATION FOR ANY ALTERNATES MAY BE GROUNDS FOR REJECTION OF THE BID. THE STATE RESERVES THE RIGHT TO WAIVE MINOR IRREGULARITIES IN BIDS OR SPECIFICATIONS IN ACCORDANCE WITH SECTION 148-1-4(F) OF THE WEST VIRGINIA LEGISLATIVE RULES AND REGULATIONS.</p> <p>EXHIBIT 5</p> <p>WEST VIRGINIA CODE 21-1D-5 PROVIDES THAT: ANY SOLICITATION FOR A PUBLIC IMPROVEMENT CONSTRUCTION CONTRACT REQUIRES EACH VENDOR THAT SUBMITS A BID FOR THE WORK T SUBMIT AT THE SAME TIME AN AFFIDAVIT OF COMPLIANCE WITH THE BID. THE ENCLOSED DRUG-FREE WORKPLACE AFFIDAVIT MUST BE SIGNED AND SUBMITTED WITH THE BID AS EVIDENCE OF THE VENDOR'S COMPLIANCE WITH THE PROVISIONS OF ARTICLE 1D, CHAPTER 21 OF THE WEST VIRGINIA CODE. FAILURE TO SUBMIT THE SIGNED DRUG-FREE WORKPLACE AFFIDAVIT WIT</p>						

SEE REVERSE SIDE FOR TERMS AND CONDITIONS

SIGNATURE	TELEPHONE	DATE
TITLE	FEIN	ADDRESS CHANGES TO BE NOTED ABOVE

WHEN RESPONDING TO RFQ, INSERT NAME AND ADDRESS IN SPACE ABOVE LABELED 'VENDOR'



State of West Virginia
 Department of Administration
 Purchasing Division
 2019 Washington Street East
 Post Office Box 50130
 Charleston, WV 25305-0130

**Request for
 Quotation**

RFQ NUMBER
 MMB11028

PAGE
 7

ADDRESS CORRESPONDENCE TO ATTENTION OF
 ROBERTA WAGNER
 304-558-0067

RFQ COPY
 TYPE NAME/ADDRESS HERE

HEALTH AND HUMAN RESOURCES
 MILDRED MITCHELL-BATEMAN
 HOSPITAL
 530 NORWAY AVENUE
 HUNTINGTON, WV
 25705 304-525-7801

DATE PRINTED 11/10/2010	TERMS OF SALE	SHIP VIA	F.O.B.	FREIGHT TERMS
----------------------------	---------------	----------	--------	---------------

BID OPENING DATE: 12/23/2010 BID OPENING TIME 01:30PM

LINE	QUANTITY	UOP	CAT NO.	ITEM NUMBER	UNIT PRICE	AMOUNT
<p>THE BID SHALL RESULT IN DISQUALIFICATION OF SUCH BID.</p> <p>NOTICE TO PROCEED: THIS CONTRACT IS TO BE PERFORMED WITHIN 120 CALENDAR DAYS AFTER THE NOTICE TO PROCEED IS RECEIVED. UNLESS OTHERWISE SPECIFIED, THE FULLY EXECUTED PURCHASE ORDER WILL BE CONSIDERED NOTICE TO PROCEED.</p> <p>CANCELLATION: THE DIRECTOR OF PURCHASING RESERVES THE RIGHT TO CANCEL THIS CONTRACT IMMEDIATELY UPON WRITTEN NOTICE TO THE VENDOR IF THE MATERIALS OR WORKMANSHIP SUPPLIED ARE OF AN INFERIOR QUALITY OR DO NOT CONFORM WITH THE SPECIFICATIONS OF THE BID AND CONTRACT HERE IN.</p> <p>WAGE RATES: THE CONTRACTOR OR SUBCONTRACTOR SHALL PAY THE HIGHER OF THE U.S. DEPARTMENT OF LABOR MINIMUM WAGE RATES AS ESTABLISHED FOR CABELL COUNTY, PURSUANT TO WEST VIRGINIA CODE 21-5A, ET, SEQ. (PREVAILING WAGE RATES APPLY TO THIS PROJECT)</p> <p>ARBITRATION: ANY REFERENCES MADE TO ARBITRATION OR INTEREST FOR PAYMENTS DUE (EXCEPT FOR ANY INTEREST REQUIRED BY STATE LAW) CONTAINED IN THIS CONTRACT OR IN ANY AMERICAN INSTITUTE OF ARCHITECTS DOCUMENTS PERTAINING TO THIS CONTRACT ARE HEREBY DELETED.</p> <p>WORKERS' COMPENSATION: VENDOR IS REQUIRED TO PROVIDE A CERTIFICATE FROM WORKERS' COMPENSATION IF SUCCESSFUL.</p> <p>ALL OF THE ITEMS CHECKED BELOW WILL BE A REQUIREMENT OF THIS CONTRACT:</p> <p>(XX) INSURANCE: SUCCESSFUL VENDOR SHALL FURNISH PROOF OF COMMERCIAL GENERAL LIABILITY INSURANCE PRIOR TO ISSUANCE OF CONTRACT. UNLESS OTHERWISE SPECIFIED IN</p>						

SEE REVERSE SIDE FOR TERMS AND CONDITIONS

SIGNATURE	TELEPHONE	DATE
TITLE	FEIN	ADDRESS CHANGES TO BE NOTED ABOVE

WHEN RESPONDING TO RFQ, INSERT NAME AND ADDRESS IN SPACE ABOVE LABELED 'VENDOR'



State of West Virginia
 Department of Administration
 Purchasing Division
 2019 Washington Street East
 Post Office Box 50130
 Charleston, WV 25305-0130

Request for Quotation

RFQ NUMBER:
 MMB11028

PAGE:
 8

ADDRESS CORRESPONDENCE TO ATTENTION OF:
 ROBERTA WAGNER
 304-558-0067

VENDOR

RFQ COPY
 TYPE NAME/ADDRESS HERE

STATE OF WEST VIRGINIA
 HEALTH AND HUMAN RESOURCES
 MILDRED MITCHELL-BATEMAN
 HOSPITAL
 530 NORWAY AVENUE
 HUNTINGTON, WV
 25705 304-525-7801

DATE PRINTED	TERMS OF SALE	SHIP VIA	FOB	FREIGHT TERMS
11/10/2010				

BID OPENING DATE: 12/23/2010 BID OPENING TIME 01:30PM

LINE	QUANTITY	UOP	CAT NO	ITEM NUMBER	UNIT PRICE	AMOUNT
<p>THE BID DOCUMENTS, THE MINIMUM AMOUNT OF INSURANCE COVERAGE REQUIRED IS \$250,000.</p> <p>() BUILDERS RISK INSURANCE: SUCCESSFUL VENDOR SHALL FURNISH PROOF OF BUILDERS RISK - ALL RISK INSURANCE IN AN AMOUNT EQUAL TO 100% OF THE AMOUNT OF THE CONTRACT.</p> <p>(XX) BONDS: FIVE PERCENT (5%) OF THE TOTAL AMOUNT OF THE BID PAYABLE TO THE STATE OF WEST VIRGINIA, SHALL BE SUBMITTED WITH EACH BID AS A BID BOND. THE SUCCESSFUL BIDDER SHALL ALSO FURNISH A PERFORMANCE BOND AND LABOR/MATERIAL BOND FOR 100% OF THE AMOUNT OF THE CONTRACT. BONDS MAY BE PROVIDED IN THE FORM OF A CERTIFIED CHECK, IRREVOCABLE LETTER OF CREDIT, OR BOND FURNISHED BY A SOLVENT SURETY COMPANY AUTHORIZED TO DO BUSINESS IN THE STATE OF WEST VIRGINIA. A LETTER OF CREDIT SUBMITTED IN LIEU OF A BOND WILL ONLY BE ALLOWED FOR PROJECTS UNDER \$100,000. PERSONAL OR BUSINESS CHECKS ARE NOT ACCEPCTABLE IN LIEU OF THE 5% BID BOND, PERFORMANCE BOND, OR LABOR AND MATERIAL BOND.</p> <p>() MAINTENANCE BOND: A TWO (2) YEAR MAINTENANCE BOND COVERING THE ROOFING SYSTEM WILL BE A REQUIREMENT OF THE SUCCESSFUL VENDOR.</p> <p>REV. 11/00</p> <p>EXHIBIT 7</p> <p>DOMESTIC ALUMINUM, GLASS & STEEL IN PUBLIC WORKS PROJECTS</p> <p>IN ACCORDANCE WITH WEST VIRGINIA CODE 5-19-1 ET., SEQ., EVERY CONTRACT FOR CONSTRUCTION, RECONSTRUCTION, ALTERATION, REPAIR, IMPROVEMENT OR MAINTENANCE OF</p>						

Provided

SIGNATURE		TELEPHONE	DATE
TITLE	FEIN	ADDRESS CHANGES TO BE NOTED ABOVE	

WHEN RESPONDING TO RFQ, INSERT NAME AND ADDRESS IN SPACE ABOVE LABELED 'VENDOR'



State of West Virginia
 Department of Administration
 Purchasing Division
 2019 Washington Street East
 Post Office Box 50130
 Charleston, WV 25305-0130

**Request for
 Quotation**

RFQ NUMBER
 MMB11028

PAGE
 9

ADDRESS CORRESPONDENCE TO ATTENTION OF
 ROBERTA WAGNER
 304-558-0067

VENDOR

RFQ COPY
 TYPE NAME/ADDRESS HERE

SHIP TO

HEALTH AND HUMAN RESOURCES
 MILDRED MITCHELL-BATEMAN
 HOSPITAL
 1530 NORWAY AVENUE
 HUNTINGTON, WV
 25705 304-525-7801

DATE PRINTED	TERMS OF SALE	SHIP VIA	F.O.B.	FREIGHT TERMS
11/10/2010				

BID OPENING DATE: 12/23/2010 BID OPENING TIME 01:30PM

LINE	QUANTITY	UOP	CAT NO	ITEM NUMBER	UNIT PRICE	AMOUNT
<p>PUBLIC WORKS, WHERE THE COST IS MORE THAN \$50,000 AND, IN THE CASE OF STEEL ONLY, WHERE THE COST OF STEEL IS MORE THAN \$50,000 OR WHERE MORE THAN 10,000 POUNDS OF STEEL ARE REQUIRED. THE STATE WILL ACCEPT ONLY ALUMINUM GLASS, OR STEEL PRODUCTS PRODUCED IN THE UNITED STATES. IN ADDITION, ITEMS OF MACHINERY OR EQUIPMENT PURCHASED FOR USE AT THE SITE OF PUBLIC WORKS SHALL BE MADE OF DOMESTIC ALUMINUM, GLASS OR STEEL, UNLESS THE COST OF THE PRODUCT IS LESS THAN \$50,000 OR LESS THAN 10,000 POUNDS OF STEEL ARE USED IN PUBLIC WORKS PROJECTS.</p> <p>FOREIGN MADE ALUMINUM, GLASS OR STEEL PRODUCTS MAY BE ACCEPTED ONLY IF THE COST OF DOMESTIC PRODUCTS IS FOUND TO BE UNREASONABLE. SUCH COST IS UNREASONABLE IF IT IS 20% OR MORE HIGHER THAN THE BID PRICE FOR FOREIGN MADE PRODUCTS. IF THE DOMESTIC ALUMINUM, GLASS OR STEEL PRODUCTS TO BE SUPPLIED OR PRODUCED IN A "SUBSTANTIAL LABOR SURPLUS AREA", AS DEFINED BY THE UNITED STATES DEPARTMENT OF LABOR, FOREIGN PRODUCTS MAY BE SUPPLIED ONLY IF DOMESTIC PRODUCTS ARE 30% OR MORE HIGHER IN PRICE THAN THE FOREIGN MADE PRODUCTS.</p> <p>IF, PRIOR TO THE AWARD OF A CONTRACT UNDER THE ABOVE PROVISIONS, THE SPENDING OFFICER OF THE SPENDING UNIT DETERMINES THAT THERE EXISTS A BID FOR LIKE FOREIGN ALUMINUM, GLASS OR STEEL THAT IS REASONABLE AND LOWER THAN THE LOWEST BID DOMESTIC PRODUCTS, THE SPENDING OFFICE MAY REQUEST, IN WRITING, A REEVALUATION AND REDUCTION IN THE LOWEST BID FOR SUCH DOMESTIC PRODUCTS. ALL VENDORS MUST INDICATE IN THEIR BID IF THEY ARE SUPPLYING FOREIGN ALUMINUM, GLASS OR STEEL.</p> <p>REV. 3/88</p> <p>EXHIBIT 9</p>						

SEE REVERSE SIDE FOR TERMS AND CONDITIONS

SIGNATURE	TELEPHONE	DATE
TITLE	FEIN	ADDRESS CHANGES TO BE NOTED ABOVE

WHEN RESPONDING TO RFQ, INSERT NAME AND ADDRESS IN SPACE ABOVE LABELED 'VENDOR'



State of West Virginia
 Department of Administration
 Purchasing Division
 2019 Washington Street East
 Post Office Box 50130
 Charleston, WV 25305-0130

Request for Quotation

BFO NUMBER
 MMB11028

PAGE
 10

ADDRESS CORRESPONDENCE TO ATTENTION OF:
 ROBERTA WAGNER
 304-558-0067

PROPERTY

RFQ COPY
 TYPE NAME/ADDRESS HERE

PROPERTY

HEALTH AND HUMAN RESOURCES
 MILDRED MITCHELL-BATEMAN
 HOSPITAL
 1530 NORWAY AVENUE
 HUNTINGTON, WV
 25705 304-525-7801

DATE PRINTED	TERMS OF SALE	SHIP VIA	F.O.B.	FREIGHT TERMS
11/10/2010				

BID OPENING DATE: 12/23/2010 BID OPENING TIME 01:30PM

LINE	QUANTITY	UOP	CAT NO	ITEM NUMBER	UNIT PRICE	AMOUNT
<p>NOTICE FOR ISSUANCE & ACKNOWLEDGEMENT OF CONSTRUCTION PROJECT ADDENDA</p> <p>THE ARCHITECT/ENGINEER AND/OR AGENCY SHALL BE REQUIRED TO ABIDE BY THE FOLLOWING SCHEDULE IN ISSUING CONSTRUCTION PROJECT ADDENDA FOR STATE AGENCIES:</p> <p>(1) THE ARCHITECT/ENGINEER SHALL PREPARE THE ADDENDUM AND A LIST OF ALL PARTIES THAT HAVE PROCURED DRAWINGS AND SPECIFICATIONS FOR THE PROJECT. THE ADDENDUM AND LIST SHALL BE FORWARDED TO THE BUYER IN THE STATE PURCHASING DIVISION. THE ARCHITECT/ENGINEER SHALL ALSO SEND A COPY OF THE ADDENDUM TO THE STATE AGENCY FOR WHICH THE CONTRACT IS ISSUED.</p> <p>(2) THE BUYER SHALL SEND THE ADDENDUM TO ALL INTERESTED PARTIES AND, IF NECESSARY, EXTEND THE BID OPENING DATE. ANY ADDENDUM SHOULD BE RECEIVED BY THE BUYER WITHIN FOURTEEN (14) DAYS PRIOR TO THE BID OPENING DATE.</p> <p>(3) ALL ADDENDA SHOULD BE FORMALLY ACKNOWLEDGED BY ALL BIDDERS AND SUBMITTED TO THE STATE PURCHASING DIVISION. THE SAME RULES AND REGULATIONS THAT APPLY TO THE ORIGINAL BIDDING DOCUMENT SHALL ALSO APPLY TO AN ADDENDUM DOCUMENT. THE ONLY EXCEPTION MAY BE FOR AN ADDENDUM THAT IS ISSUED FOR THE SOLE PURPOSE OF CHANGING A BID OPENING TIME AND/OR DATE.</p> <p>REV. 11/96</p> <p>EXHIBIT 10</p>						

SEE REVERSE SIDE FOR TERMS AND CONDITIONS

SIGNATURE	TELEPHONE	DATE
TITLE	FEIN	ADDRESS CHANGES TO BE NOTED ABOVE

WHEN RESPONDING TO RFQ, INSERT NAME AND ADDRESS IN SPACE ABOVE LABELED 'VENDOR'



State of West Virginia
 Department of Administration
 Purchasing Division
 2019 Washington Street East
 Post Office Box 50130
 Charleston, WV 25305-0130

**Request for
 Quotation**

RFQ NUMBER
 MMB11028

PAGE
 11

ADDRESS CORRESPONDENCE TO ATTENTION OF
 ROBERTA WAGNER
 304-558-0067

RFQ COPY
 TYPE NAME/ADDRESS HERE
 VENDOR

HEALTH AND HUMAN RESOURCES
 MILDRED MITCHELL-BATEMAN
 HOSPITAL
 1530 NORWAY AVENUE
 HUNTINGTON, WV
 25705 304-525-7801

DATE PRINTED 11/10/2010	TERMS OF SALE	SHIP VIA	FOB	FREIGHT TERMS
----------------------------	---------------	----------	-----	---------------

BID OPENING DATE: 12/23/2010 BID OPENING TIME 01:30PM

LINE	QUANTITY	UOP	CAT NO	ITEM NUMBER	UNIT PRICE	AMOUNT
ADDENDUM ACKNOWLEDGEMENT						
I HEREBY ACKNOWLEDGE RECEIPT OF THE FOLLOWING CHECKED ADDENDUM(S) AND HAVE MADE THE NECESSARY REVISIONS TO MY PROPOSAL, PLANS AND/OR SPECIFICATION, ETC.						
ADDENDUM NOS.:						
NO. 1		Yes				
NO. 2						
NO. 3						
NO. 4						
NO. 5						
I UNDERSTAND THAT FAILURE TO CONFIRM THE RECEIPT OF THE ADDENDUM(S) MAY BE CAUSE FOR REJECTION OF THE BIDS.						
VENDOR MUST CLEARLY UNDERSTAND THAT ANY VERBAL REPRESENTATION MADE OR ASSUMED TO BE MADE DURING ANY ORAL DISCUSSION HELD BETWEEN VENDOR'S REPRESENTATIVES AND ANY STATE PERSONNEL IS NOT BINDING. ONLY THE INFORMATION ISSUED IN WRITING AND ADDED TO THE SPECIFICATIONS BY AN OFFICIAL ADDENDUM IS BINDING.						
				SIGNATURE		
Lonny Secor, Comaco Systems, LLC				COMPANY		
1-6-11				DATE		
REV. 11/96						

SEE REVERSE SIDE FOR TERMS AND CONDITIONS

SIGNATURE	TELEPHONE	DATE
TITLE	FEIN	ADDRESS CHANGES TO BE NOTED ABOVE

WHEN RESPONDING TO RFQ, INSERT NAME AND ADDRESS IN SPACE ABOVE LABELED 'VENDOR'



State of West Virginia
 Department of Administration
 Purchasing Division
 2019 Washington Street East
 Post Office Box 50130
 Charleston, WV 25305-0130

Request for Quotation

RFQ NUMBER
 MMB11028

PAGE
 12

ADDRESS CORRESPONDENCE TO ATTENTION OF
 ROBERTA WAGNER
 304-558-0067

VENDOR

RFQ COPY
 TYPE NAME/ADDRESS HERE

VENDOR

HEALTH AND HUMAN RESOURCES
 SMILDRED MITCHELL-BATEMAN
 HOSPITAL
 1530 NORWAY AVENUE
 HUNTINGTON, WV
 25705 304-525-7801

DATE PRINTED	TERMS OF SALE	SHIP VIA	FOB	FREIGHT TERMS
11/10/2010				

BID OPENING DATE: 12/23/2010 BID OPENING TIME 01:30PM

LINE	QUANTITY	LOF	CAT NO	ITEM NUMBER	UNIT PRICE	AMOUNT
<p>CONTRACTORS LICENSE</p> <p>WEST VIRGINIA STATE CODE 21-11-2 REQUIRES THAT ALL PERSONS DESIRING TO PERFORM CONTRACTING WORK IN THIS STATE MUST BE LICENSED. THE WEST VIRGINIA CONTRACTORS LICENSING BOARD IS EMPOWERED TO ISSUE THE CONTRACTORS LICENSE. APPLICATIONS FOR A CONTRACTORS LICENSE MAY BE MADE BY CONTACTING THE WEST VIRGINIA DIVISION OF LABOR CAPITOL COMPLEX, BUILDING 3, ROOM 319, CHARLESTON, WV 25305. TELEPHONE: (304) 558-7890.</p> <p>WEST VIRGINIA STATE CODE 21-11-11 REQUIRES ANY PROSPECTIVE BIDDER TO INCLUDE THE CONTRACTORS LICENSE NUMBER ON THEIR BID.</p> <p>BIDDER TO COMPLETE:</p> <p>CONTRACTORS NAME: <i>Lange Security Camera Systems LLC</i></p> <p>CONTRACTORS LICENSE NO.: <i>WV 040102</i></p> <p>THE SUCCESSFUL BIDDER WILL BE REQUIRED TO FURNISH A COPY OF THEIR CONTRACTORS LICENSE PRIOR TO ISSUANCE OF A PURCHASE ORDER/CONTRACT</p> <p>APPLICABLE LAW</p> <p>THE WEST VIRGINIA STATE CODE, PURCHASING DIVISION RULE AND REGULATIONS, AND THE INFORMATION PROVIDED IN THE "REQUEST FOR QUOTATION" ISSUED BY THE PURCHASING DIVISION IS THE SOLE AUTHORITY GOVERNING THIS PROCUREMENT.</p> <p>ANY INFORMATION PROVIDED IN SPECIFICATION MANUALS, OR</p>						

SEE REVERSE SIDE FOR TERMS AND CONDITIONS

SIGNATURE	TELEPHONE	DATE
TITLE	FEIN	ADDRESS CHANGES TO BE NOTED ABOVE

WHEN RESPONDING TO RFQ, INSERT NAME AND ADDRESS IN SPACE ABOVE LABELED 'VENDOR'



State of West Virginia
 Department of Administration
 Purchasing Division
 2019 Washington Street East
 Post Office Box 50130
 Charleston, WV 25305-0130

Request for Quotation

RFQ NUMBER
MMB11028

PAGE
13

ADDRESS CORRESPONDENCE TO ATTENTION OF
ROBERTA WAGNER 304-558-0067

VENDOR

RFQ COPY
 TYPE NAME/ADDRESS HERE

STATE OF WEST VIRGINIA

HEALTH AND HUMAN RESOURCES
 CHILDRED MITCHELL-BATEMAN
 HOSPITAL
 1530 NORWAY AVENUE
 HUNTINGTON, WV
 25705 304-525-7801

DATE PRINTED	TERMS OF SALE	SHIP VIA	FOB	FREIGHT TERMS
11/10/2010				

BID OPENING DATE: 12/23/2010 BID OPENING TIME 01:30PM

LINE	QUANTITY	UOP	CAT NO	ITEM NUMBER	UNIT PRICE	AMOUNT
<p>ANY OTHER SOURCE, VERBAL OR WRITTEN, WHICH CONTRADICTS OR ALTERS THE INFORMATION PROVIDED FROM THE SOURCES AS DESCRIBED IN THE ABOVE PARAGRAPH IS VOID AND OF NO EFFECT.</p> <p>BANKRUPTCY: IN THE EVENT THE VENDOR/CONTRACTOR FILES FOR BANKRUPTCY PROTECTION, THE STATE MAY DEEM THE CONTRACT NULL AND VOID, AND TERMINATE SUCH CONTRACT WITHOUT FURTHER ORDER.</p> <p>REV. 5/2009</p> <p style="text-align: center;">NOTICE</p> <p>A SIGNED BID MUST BE SUBMITTED TO:</p> <p style="text-align: center;">DEPARTMENT OF ADMINISTRATION PURCHASING DIVISION BUILDING 15 2019 WASHINGTON STREET, EAST CHARLESTON, WV 25305-0130</p> <p>THE BID SHOULD CONTAIN THIS INFORMATION ON THE FACE OF THE ENVELOPE OR THE BID MAY NOT BE CONSIDERED:</p> <p>SEALED BID</p> <p>BUYER:-----RW/FILE 22-----</p> <p>REQ. NO.:-----MMB11028-----</p> <p>BID OPENING DATE:-----12/23/2010-----</p> <p>BID OPENING TIME:-----1:30 PM-----</p>						

SEE REVERSE SIDE FOR TERMS AND CONDITIONS

SIGNATURE	TELEPHONE	DATE
TITLE	FEIN	ADDRESS CHANGES TO BE NOTED ABOVE

WHEN RESPONDING TO RFQ, INSERT NAME AND ADDRESS IN SPACE ABOVE LABELED 'VENDOR'



State of West Virginia
 Department of Administration
 Purchasing Division
 2019 Washington Street East
 Post Office Box 50130
 Charleston, WV 25305-0130

Request for Quotation

RFQ NUMBER
 MMB11028

PAGE
 14

ADDRESS CORRESPONDENCE TO ATTENTION OF:
 ROBERTA WAGNER
 304-558-0067

VENDOR

RFQ COPY
 TYPE NAME/ADDRESS HERE

SHIP TO

HEALTH AND HUMAN RESOURCES
 MILDRED MITCHELL-BATEMAN
 HOSPITAL
 1530 NORWAY AVENUE
 HUNTINGTON, WV
 25705 304-525-7801

DATE PRINTED	TERMS OF SALE	SHIP VIA	FOB	FREIGHT TERMS
11/10/2010				

BID OPENING DATE: 12/23/2010 BID OPENING TIME 01:30PM

LINE	QUANTITY	UOP	CAT. NO.	ITEM NUMBER	UNIT PRICE	AMOUNT
PLEASE PROVIDE A FAX NUMBER IN CASE IT IS NECESSARY TO CONTACT YOU REGARDING YOUR BID: ----- 304-925-8338 ----- PLEASE PRINT OR TYPE NAME OF PERSON TO CONTACT CONCERNING THIS QUOTE: ----- Alan E. Long ----- PLEASE NOTE: A CONVENIENCE COPY WOULD BE APPRECIATED. ***** THIS IS THE END OF RFQ MMB11028 ***** TOTAL:						

SEE REVERSE SIDE FOR TERMS AND CONDITIONS

SIGNATURE	TELEPHONE	DATE
TITLE	FEIN	ADDRESS CHANGES TO BE NOTED ABOVE

WHEN RESPONDING TO RFQ, INSERT NAME AND ADDRESS IN SPACE ABOVE LABELED 'VENDOR'

System VII - meeting today's demands and tomorrow's challenges.

- Supports multiple-monitor workstations
- Compatible with Microsoft's latest OS - Windows 7 Professional, Enterprise & Ultimate versions
- Supports multiple communication modes - serial, LAN/WAN, Reverse Network & modem
- Has user-selectable languages - English, French & Spanish
- Emails alarms or critical messages automatically to PCs, cell phones, or pagers
- Has alarm summary, instructions & interactive maps for timely response
- Offers user-formatted transaction reports for management analysis & overview
- Has time-saving import & export feature for cardholder records
- Offers advanced CCTV integration (optional)
- Schedules automatic database backups with email notification for protection of site records
- Has a Disaster Recovery utility for added safety of system data
- Includes context-sensitive on-line help with detailed instructions
- Has "First Person In" feature to stop unauthorized persons from gaining access to doors set on timed auto-unlock
- Has "dual custody" reader mode for enhanced security
- Has a "Not Used Since" feature to conveniently identify non-active cardholders
- Has an "Accessibility" feature with separate door monitor settings for individuals who require longer access time
- Includes a temporary card feature with date range and usage countdown beneficial for visitors or memberships
- Allows for on-going system expansion without having to purchase new software

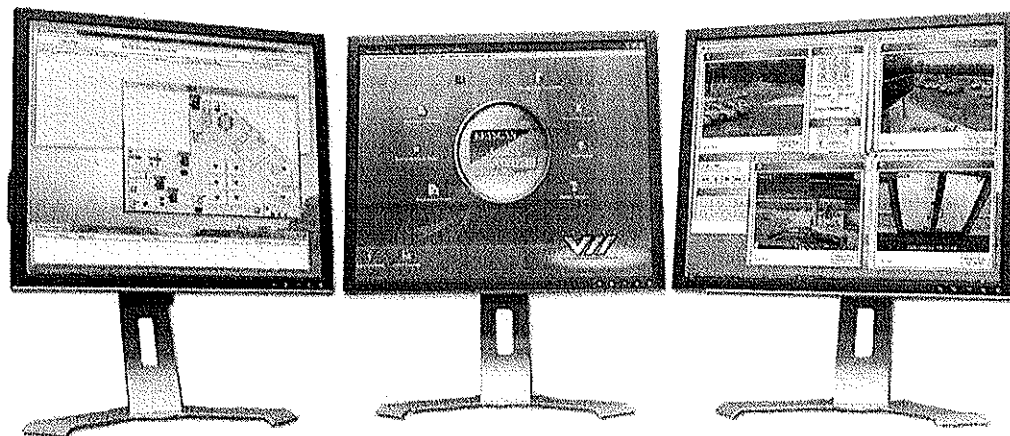

Keyscan's CCTV module - K-TV - integrates with most RS232 camera systems, with select DVRs, listed below, and IP addressable cameras.

- Multiple CCTV windows available with multi-monitor capability
- Monitor multiple video feeds and use on-screen camera commands to zero in on a subject of concern
- Fast retrieval of recorded CCTV images captured during a system-triggered event such as a forced entry
- Conveniently switch from the alarm monitoring screen to the live video screen in the click of a mouse
- Automate cameras to record an alarm event so security personnel see what's happening and where it's happening
- Combined with Keyscan's optional K-BADGE module, compare a cardholder's on-file image to a live video image at any reader controlled access point that is equipped with a CCTV camera

Supported DVRs

Keyscan (K-DVR & DVR2-2TB, KDVR2-4TB), Bosch ***, Dedicated Micros (Net Vu), Exacq, Honeywell (Fusion), Integral ***, Open Eye ***, Pelco (DX8000, DX8100 and Endura), and Toshiba (Surveillix) digital video recorders.

*** Limited model support. Contact Keyscan for details.

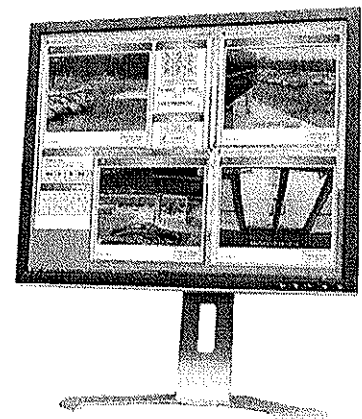

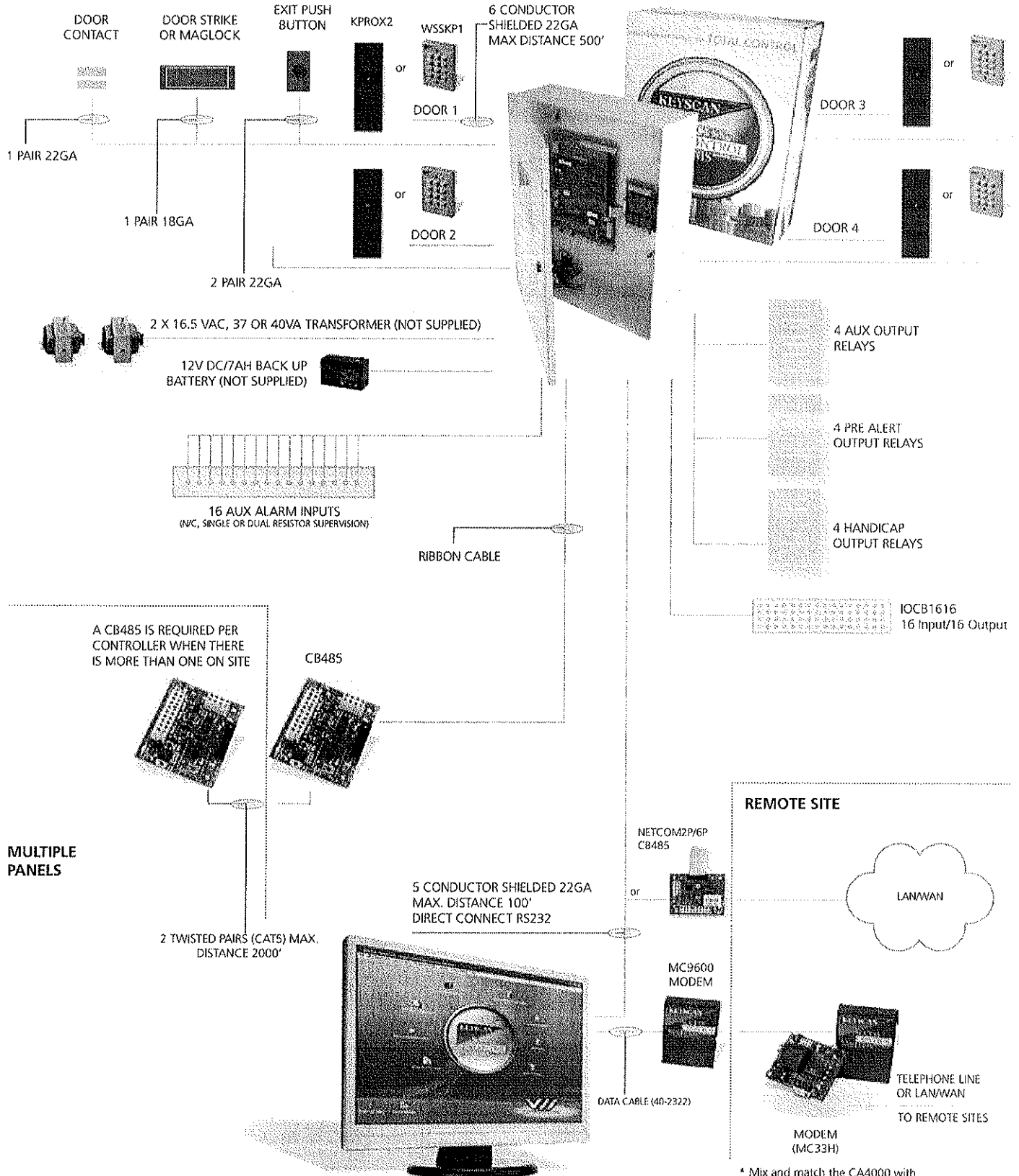

* Mix and match the CA4000 with Keyscans family of controllers

OVERVIEW OF THE FEATURES IN EVERY KEYSKAN SYSTEM

PANEL NAME	CA 200	CA 4000	CA 8000	EC 1000	EC 2000
DOOR OUTPUT RELAYS	2	4	8	NA	NA
CARDS	32000	32000	32000	32000	32000
TRANSACTION FILE BUFFER	6000	6000	6000	6000	6000
TIME ZONES	256	256	256	256	256
TIME SCHEDULES	512	512	512	512	512
GROUP LEVELS	511	511	511	511	511
HOLIDAY DATES	63	63	63	63	63
VISITOR CARD	YES	YES	YES	YES	YES
READERS	2	4	8	1	2
KEYPADS	2	4	8	1	2
READER/DOOR INPUTS	2	4	8	NA	NA
EXIT BUTTON INPUTS	2	4	8	NA	NA
ALARM OUTPUT RELAYS	2	4	8	NA	NA
AUXILIARY INPUTS	8	16	16	NA	NA
SUPERVISED INPUTS (OPTIONAL)	NA	32/64	32/64	NA	NA
IOCB 1616 SUPERVISED INPUT/OUTPUTS (OPTIONAL)	NA	16-64	16-64	NA	NA
POWER FAIL OUTPUT	YES	YES	YES	NO	NA
ELEVATOR CONTROL	NA	NA	NA	1x40 Flrs	2x16 Flrs
FLOOR MONITOR INPUTS	NA	NA	NA	YES	YES
CONTROL PROCESSORS	2	2	2	2	2
MANUAL RELAY OVERRIDE	YES	YES	YES	YES	YES
INDIVIDUAL TIME ZONES PER DOOR/READER	YES	YES	YES	NA	NA
INDIVIDUAL TIME ZONES PER FLOOR	NA	NA	NA	YES	YES
DIAL-UP MODEM ON REMOTE ALARM	YES	YES	YES	NA	NA
TIME ZONE CONTROL ON KEYPAD/READER USE	YES	YES	YES	NO	NO
MULTI SITE CARD WITH BATCH/FACILITY CODE	YES	YES	YES	YES	YES
SERIAL COMMUNICATION	YES	YES	YES	YES	YES
DIAL-UP COMMUNICATION (OPTIONAL)	YES	YES	YES	YES	YES
LAN/WAN COMMUNICATION (OPTIONAL)	YES	YES	YES	YES	YES
ADD ON SUPPRESSOR KIT REQUIRED	NO	NO	NO	NO	NO

KEYSCAN'S INTEGRATION AND DYNAMICS ALLOWS COMPANIES TO START WITH A SMALL SYSTEM AND GROW TO A FULL NETWORK OF SECURITY AND BUILDING MANAGEMENT.



KEYSCAN INC.

901 Burns Street East

Whitby, Ontario L1N 6A6

Phone: 905.430.7226 Toll Free: 1.888.539.7226 Fax: 905.430.7275

www.keyscan.ca

CB-485 / NETCOM2P / CB-485M

RS-485 Communication Board

CB-485

- Establishes RS-485 communication between multiple access control units (ACU) and the PC
- Reliable PC to ACU communication
- Enhanced communication speed
- Increases maximum wiring distance on ACU communication loop
- Easily connects to ACU via ribbon cable
- Mounts directly in ACU enclosure
- Uses two twisted pairs on CAT5 cable

Optional CB-485 configuration with NETCOM2P

(Network TCP/IP module)

- NETCOM2P plugs into socket on CB-485
- Delivers multiple ACU communication to PC over a LAN/WAN (TCP/IP)
- Suitable for 10/100 Ethernet/Fast Ethernet applications
- Uses static IP address

CB-485M

- CB-485M expands system capability with built-in dial up modem to link remote sites
- Designed specifically for Keyscan access control units
- Uses standard analog phone line
- Pre-loaded setup parameters
- Mounts directly in ACU enclosure
- Only one CB-485M required for multiple ACUs on same communication loop

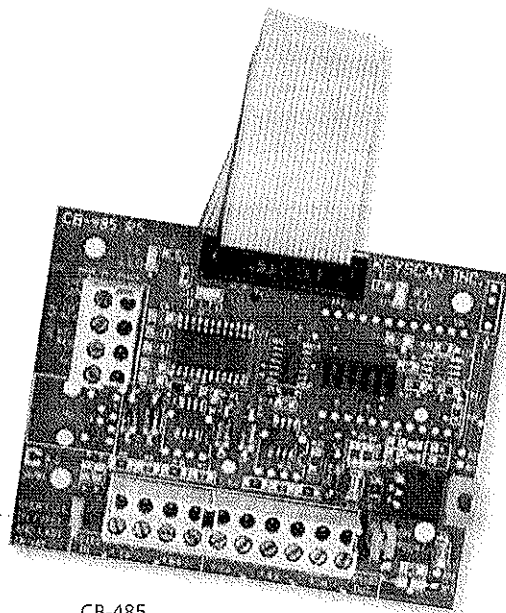

CB-485

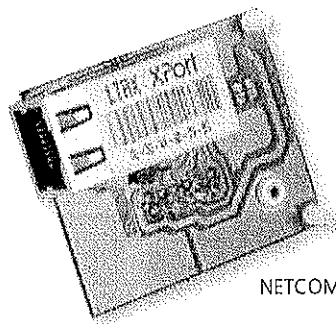

NETCOM2P

CB-485 / NETCOM2P / CB-485M

RS-485 Communication Board

FEATURES AND BENEFITS

- Maximum distance of up to 2000 feet (600m) between ACUs
- Cost effective and ease of connection between panels using CAT5
- Can communicate to PC using direct connect, or with optional NETCOM2P module (TCP/IP), or with CB-485M (modem)

APPLICATIONS

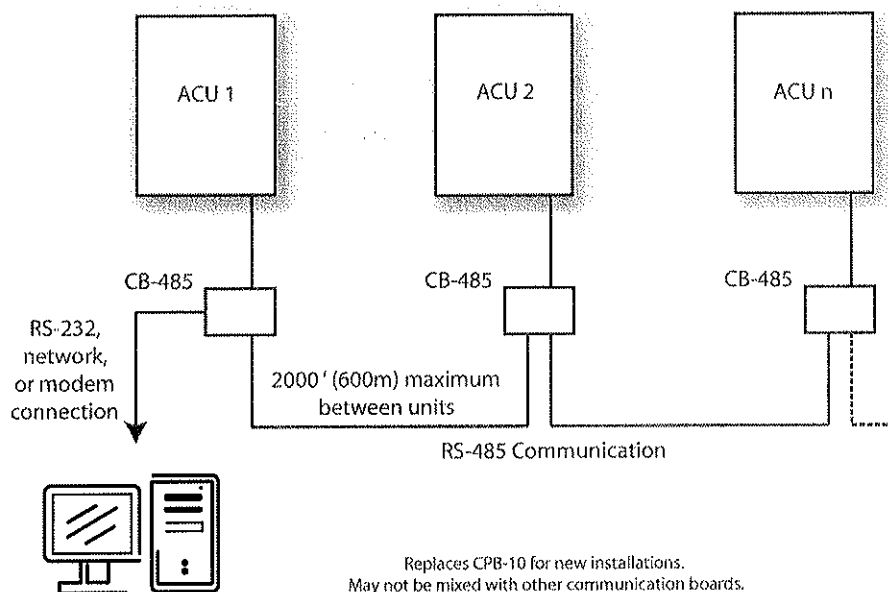

SPECIFICATIONS

Power

5VDC from ACU

CB-485 - 110 mA, CB-485M - 360 mA, CB-485 with NETCOM2P - 250mA

Baud Rates

up to 57,600 (CB-485 only)

Cable

CB-485 to CB-485 - CAT5, 4 conductor

CB-485M to CB-485 - CAT5, 6 conductor

RS-485 Full Duplex communication

Maximum distance between two access

control units - 2000 feet (600m)

CB-485 boards must be daisy chained (parallel) to each other

ACU-PC - 100 feet max (30m)

Dimensions

CB-485 3 5/8" x 2" (9.0 cm x 6.9 cm)

Environmental Tolerances

Suitable for commercial and industrial applications

Relative Humidity: 0% to 90% R.H., non-condensing

Operating Temperatures: -20° to 71° C (-4° to 160° F)

Storage Temperatures: -20° to 85° C (-4° to 185° F)

KEYSCAN INC.

901 Burns Street East

Whitby, Ontario L1N 6A6

Phone: 905.430.7226 Toll Free: 1.888.539.7226 Fax: 905.430.7275

www.keyscan.ca

Want more information? Contact your local representative at:

NETCOM2 & NETCOM2H

RS232 TCP/IP CONVERTER

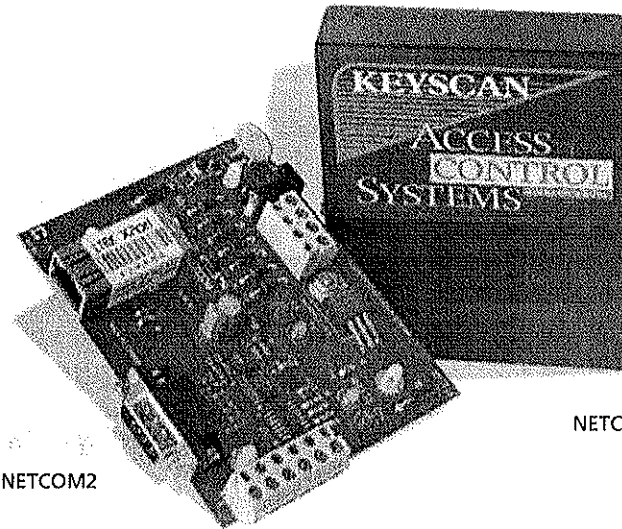

NETCOM2

NETCOM2H

- Keyscan's NETCOM2 is for 10/100 Ethernet/Fast Ethernet applications.
- Keyscan's NETCOM2H is an external version in a housing and CW power supply.
- Enables Keyscan Access Control Units to be connected and communicate over a network.
- NETCOM2 provides serial connection from the Access Control Unit(s) via 10/100 RJ45 network interface to communicate with the PC.
- Uses static TCP/IP addresses to allow communications over existing LAN or WAN networks.
- Unlimited remote NETCOM2's can be added to a system, offering an enterprise solution.
- NETCOM2 Powered from ACU 12VDC with Battery.
- NETCOM2H powered from provided 12V DC transformer.
- Fast, easy, trouble-free installation to place Access Control Units on a network.

NETCOM2 & NETCOM2H

RS232 TCP/IP CONVERTER

FEATURES AND BENEFITS

- Allows one or more Access Control Units to communicate on a LAN/WAN.
- Fast easy installation for the Access Control Unit (ACU).
- Configuration for the NETCOM2 simplified with Keyscan's software interface.
- Static TCP/IP communication protocol between the PC NIC (Network Interface Card) and Access Control Unit(s) (NETCOM2).
- Requires Static IP addresses for proper operation
- Save Modem Line costs for controlling Remote Locations using existing LAN/WAN's.
- The NETCOM2 can be installed inside the ACU and wired directly to the ACU with the RJ45 Network Connection or located by the Network Hub and be wired up to 100' from the ACU.
- The NETCOM2H comes complete with a housing and power supply for external Network connections.
- Simplifies both installation and maintenance procedures.

APPLICATIONS

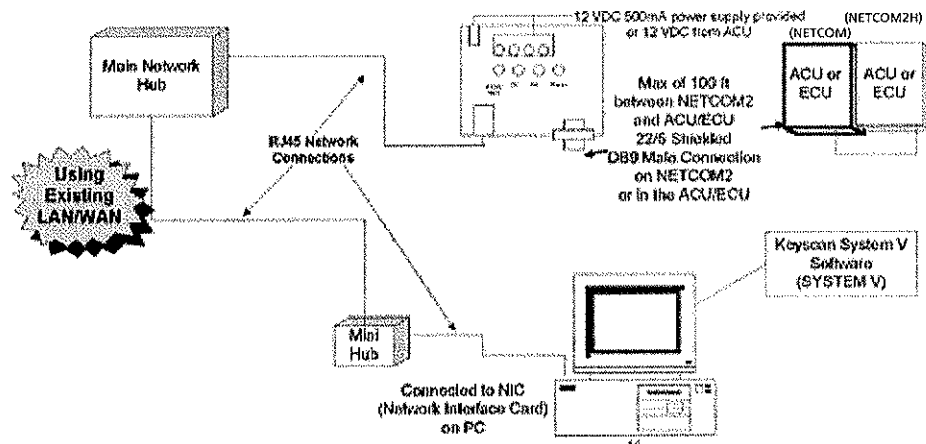

SPECIFICATIONS

NETCOM2 Requirements:

Input power: 10.2 to 32 VDC, 210 mA

NETCOM2 Powered by Access Control Unit

NETCOM2H power supply included

Cable Maximums:

ACU/ECU to NETCOM2 – 100 ft (22 AWG 3 pair shielded)

NETCOM2 to PC – Existing LAN or WAN (static TCP/IP Protocol)

Agency Approvals: complies with Class B limits of EN 55022:1998

Direct & Indirect ESD - complies with EN55024:1998

Dimensions:

3.031" x 3.896" (77mm x 99mm)

With Housing: 3.85" x 4.5" (97.85mm x 114.3mm)

Environmental Tolerances:

Suitable for commercial and industrial applications.

Operating Temperature: -20° to 71° C (-4° to 158° F)

Storage Temperature: -20° to 85° C (-4° to 158° F)

KEYSCAN INC.

901 Burns Street East

Whitby, Ontario Canada L1N 6A6

Tel: 905.430.7226 Toll Free: 1.888.539.7226 Fax: 905.430.7275

Web: www.keyscaan.ca

Want more information? Contact your local representative at:

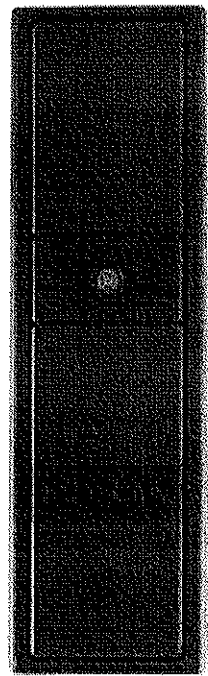

K-PROX2

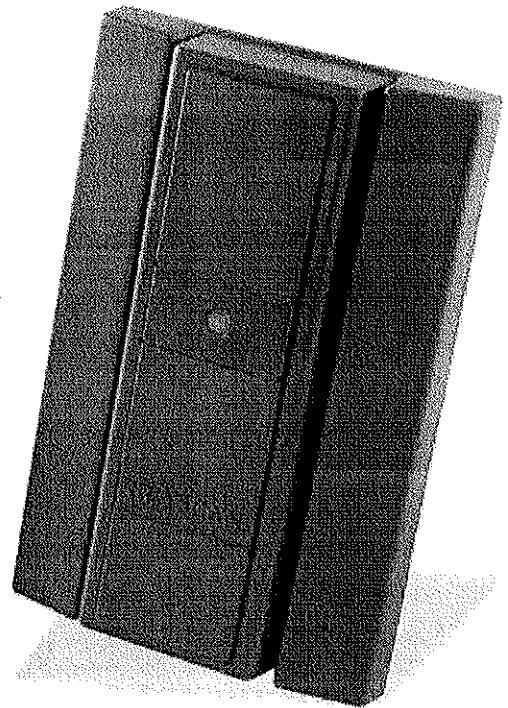

- Simple 2 in 1 unit; mullion or single gang electrical box applications
- Discard removable switch plate for mullion installations
- Compatible with HID proximity cards and tags over a range of Wiegand protocols
- Electronics secured in tamper-resistant epoxy potting for added protection
- Install on any surface including single gang wall switch
- Durable, weather-resistant construction for reliable operation and long usage even in harsh environments
- Limited lifetime warranty against defects in materials and workmanship

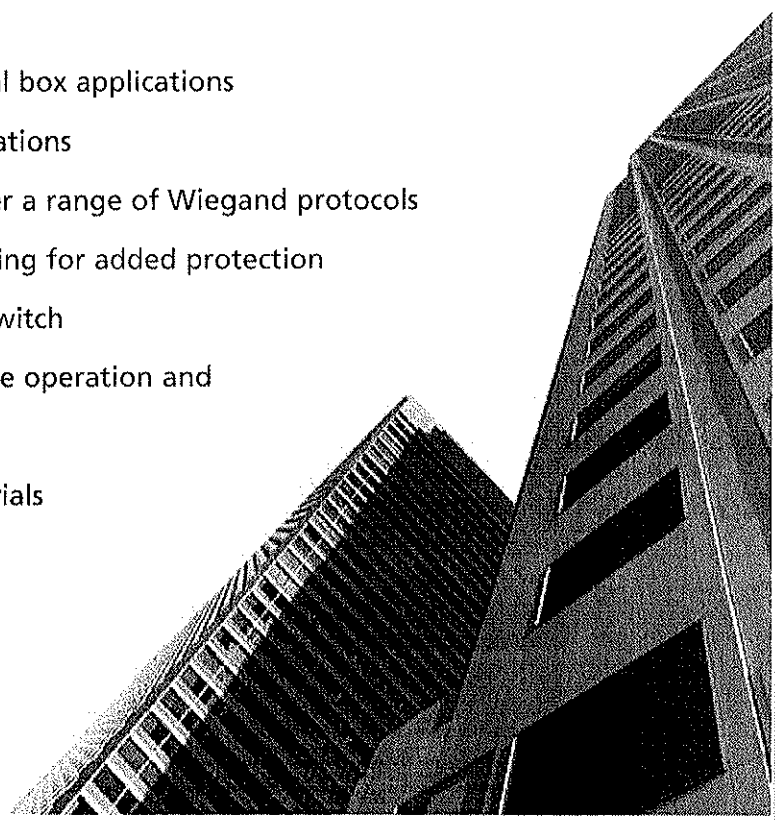

Features and Benefits

- Uses proven digital radio frequency identification technology
- Includes ABS wall witch plate
- HID compatible over a wide range of Wiegand protocols
- Designed for indoor and outdoor environments
- Unique and versatile design for easy installation

Specifications

Size

- Mullion - 4.5" (11.43 cm) x 1.5" (3.8 cm) x 0.62" (1.6 cm)
- Switch Plate - 4.5" (11.43 cm) x 3" (7.62 cm) x 0.62" (1.6 cm)

Read Range

- Off metal - up to 6" (15.2 cm)
- On metal - up to 4" (10.2 cm)

Input Voltage

- 12VDC at reader

Typical Current Draw

- Nominal draw is 40 mA
- Maximum draw is 80 mA during card read

Operating Temperature

- - 40° C to 65° C (- 40° F to 149° F)

Cable Distance

- 12" wire pigtail standard
- Wiegand interface 500 feet (152 metres)
6 conductor shielded 22 AWG

Indoor/Outdoor Design

- Secured in a rugged, tamper-resistant epoxy potting designed to withstand harsh weather conditions
- Easily installed in any location

Certifications

- IC (Industry Canada), FCC, CE

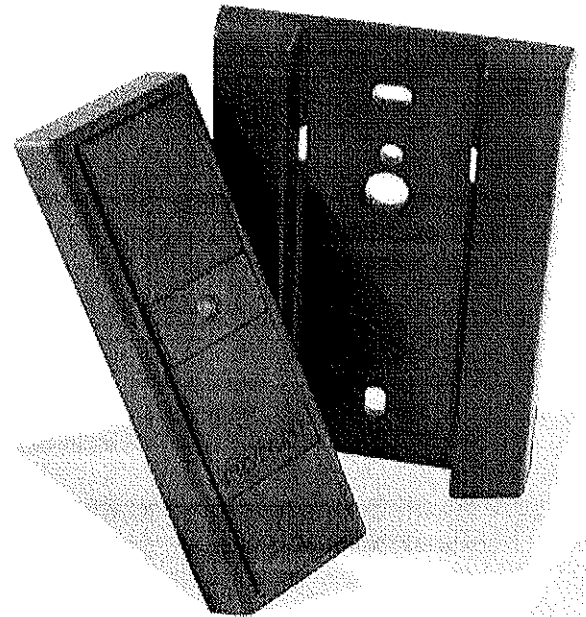

K-PROX2

KEYSCAN INC.

901 Burns Street East
Whitby, Ontario, Canada L1N 6A6
Telephone: 905-430-7226 Facsimile: 905-430-7275
Toll Free: 1-888-539-7226 (Canada/USA)
Web: www.keyscan.ca

Want more information? Contact your local representative at:

KEYSCAN

ACCESS
CONTROL
SYSTEMS

HID Proximity



The word that best summarizes the Keyscan HID proximity readers & cards is "convenience".

- Convenience for an employee who can use the same HID card to open the gate of a secured parking lot, enter the building, clock in for payroll and attendance, document the checkout of tools and equipment, enable controls for restricted machinery.
- Convenience for building management who need maintenance free equipment.
- Convenience for security personnel who need to know that the people they protect are safe.

Proximity Products - Proximity provides the highest level of convenience and ease-of-use available in access control technology, and is now the most utilized technology in new access control installations. Proximity cards and key-fobs need only be placed within proximity of their readers to activate the system. The technology is cost-effective and it is unaffected by dirty environments, weather conditions or strong magnetic fields.

Because not everyone needs smart cards. Keyscan's 36 Bit HID proximity readers and cards will continue to be the industry-leading solution. With a variety of readers and cards it is easier to upgrade to proximity and provides an alternate form of credential. Your investment in proximity is safe with Keyscan & HID!

Keyscan HID Proximity readers & cards offer:

- Off the shelf ordering of cards and readers.
- No need to remember your last sequence of cards.
- No custom orders or delayed deliveries.

Make sure you ask for Keyscan 36 Bit HID readers and cards.

www.keysca.ca

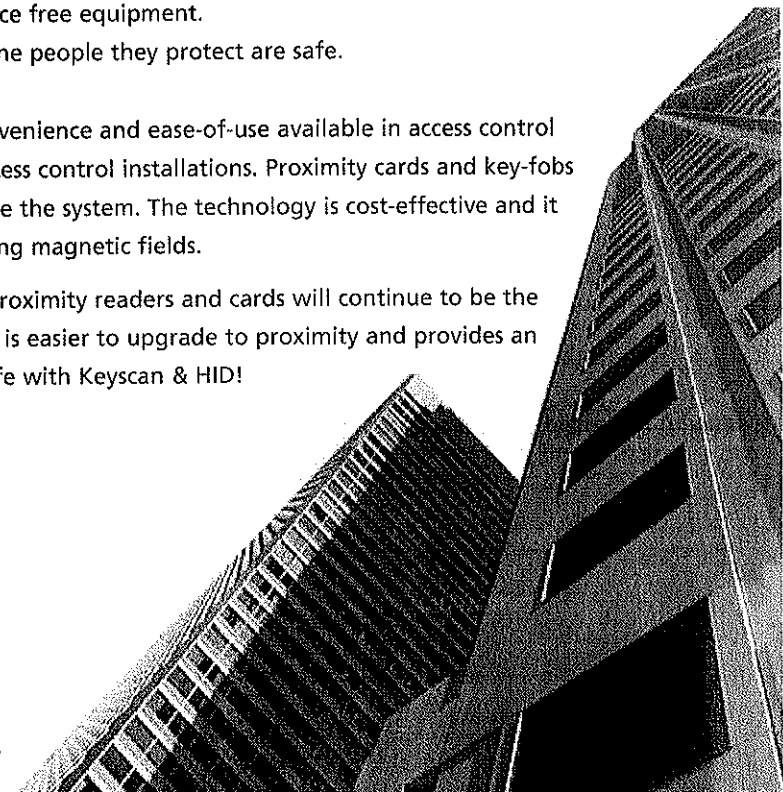

HID Proximity

READER SPECIFICATIONS:

Size:

- HID Prox Point+ (HID-6005B) 3.135" x 1.70" x 0.66" (7.96 x 4.3 x 1.68 cm)
- HID Miniprox (HID-5365) 6.0" x 1.7" x 1.0" (15.2 x 4.3 x 1.91 cm)
- HID Thinline II (HID-5395) 4.7" x 3.0" x 0.68" (11.9 x 7.6 x 1.7 cm)
- HID Proxpro (HID-5355) 5.0" x 5" x 1" (12.7 x 12.7 x 2.54 cm)
- HID Proxpro with Keypad (HID-5355KP) 5.0" x 5" x 1" (12.7 x 12.7 x 2.54 cm)
- HID Maxi Prox (HID-5375) 12" x 12" x 1" (30.5 x 30.5 x 2.54 cm)

Read Range:

- HID Prox Point+: 1-2" read range using HID-C1325 cards
- HID Miniprox: 4-5" read range using HID-C1325 cards
- HID Thinline II: 4-5" read range using HID-C1325 cards
- HID Proxpro: 5-8" read range using HID-C1325 cards
- HID Proxpro with Keypad: 5-8" read range using HID-C1325 cards
- HID Maxiprox: 16-24" read range using HID-C1325 cards

Input Voltage:

- HID Prox Point+: 12VDC at reader
- HID Miniprox: 12VDC at reader
- HID Thinline II: 12VDC at reader
- HID Proxpro: 12VDC at reader
- HID Proxpro with Keypad: 12VDC at reader
- HID Maxiprox: 24VDC at reader

Typical Current Draw:

- HID Prox Point+: 20mA avg 75mA peak at 12VDC
- HID Miniprox: 20mA avg 110mA peak at 12VDC
- HID Thinline II: 20mA avg 115mA peak at 12VDC
- HID Proxpro: 100mA avg 120mA peak at 12VDC
- HID Proxpro with Keypad: 100mA avg 120mA peak at 12VDC
- HID Maxiprox: 200mA avg 700 mA peak at 24VDC

Operating Temperature: -22° to 150°F (-30° to 65°C)

Operating Humidity: 0 to 95% relative humidity non-condensing

Cable Distance: Wiegand Interface: 500 feet (152 m)

Indoor/Outdoor Design: Sealed in a rugged, weatherized polycarbonate enclosure designed to withstand harsh environments, providing reliable performance and a high degree of vandal resistance. Easily installed in any location, even with the optional keypad.

Certifications:

Canada/UL 294 Listed: Access Control System Units
FCC Certification, United States, Canada
CE Mark, Fifteen EU Countries under the R&TTE Directive

Warranty: Warranted against defects in materials and workmanship for life from date of shipment.

HID-C1325

STANDARD PROXIMITY CARD

Size: 3.385" x 2.135" x 0.075"

Typical Maximum Read Range:

- HID6005B: 2 - 3" (5.1-7.6cm)
- HID-5365: 4 - 5.5" (10.2-14.0cm)
- HID-5395: 4 - 5.5" (10.2 - 14.0cm)
- HID-5355 and HID-5355KP: 6 - 9" (14-20.3cm)
- HID-5375: 16 - 29" (40.6-73.7cm)

Operating Temperature: -50° to 160°F (-45° to 70°C)

Packaging: 50 sequential units per package

Warranty: Lifetime

HID-T1345

PROXIMITY KEY TAG

Size: 1.9 x .900 x 0.16" (4.3 x 2.29 x 0.41cm)

Typical Maximum Read Range:

- HID6005B: 1 - 1.5" (2.5 - 3.8 cm)
- HID-5365: 1 - 2" (2.5 -5.1 cm)
- HID-5395: 1 - 2" (2.5 - 5.1 cm)
- HID-5355 and HID-5355KP: 1 - 4" (2.5 - 10.2cm)
- HID-5375: 4 - 15" (10.2 - 38cm)

Operating Temperature: -50° to 160°F (-45° to 70°C)

Packaging: 50 sequential units per package

Warranty: Lifetime

HID-C1386

PHOTO IMAGING PROXIMITY CARD

Size: 3.37 x 2.125 x 0.030" (8.6 x 5.4 x 0.076 cm)

Typical Maximum Read Range:

- HID6005B: 1 - 1.5" (2.5 - 3.8 cm)
- HID-5365: 1 - 2" (2.5 -5.1 cm)
- HID-5395: 1 - 2" (2.5 - 5.1 cm)
- HID-5355 and HID-5355KP: 1 - 4" (2.5 - 10.2cm)
- HID-5375: 4 - 15" (10.2 - 38cm)

Operating Temperature: -50° to 160°F (-45° to 70°C)

Packaging: 50 sequential units per package

Warranty: Lifetime

HID-1391

MICRO PROXIMITY ADHESIVE TAG

Size: 1.285" (32.639mm) Diameter

Typical Maximum Read Range:

- HID-6005B: 0.5"-2.0" (1.2 - 5.1cm)
- HID-5365: 0.5" - 2.5" (1.2 - 6.4cm)
- HID-5395: 1.0" - 3.0" (2.5 - 7.6cm)
- HID-5355 and HID-5355KP: 1.0" - 4.0" (2.5 - 11.4cm)
- HID-5375: 4.0" - 15.0" (10.2 - 38cm)

Operating Temperature: -50° to 160°F (-45° to 70°C)

Packaging: 50 sequential units per package

Warranty: Lifetime

KEYSCAN INC.

901 Burns Street East

Whitby, Ontario Canada L1N 6A6

Tel: 905.430.7226 Toll Free: 1.888.539.7226 Fax: 905.430.7275

Web: www.keyscan.ca

Want more information? Contact your local representative at:

Electromagnetic Locks

8310 

8 Series MultiMag®

8320 



In or Out...we make it Easy!®

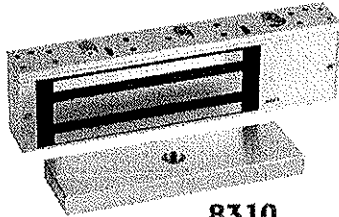

8310

Single outswinging
interior or perimeter doors
1-5/8"D x 2-7/8"W x 10-1/2"L
(41.3mm x 73.0mm x 266.7mm)
Including 1/4" (6mm) mounting bracket

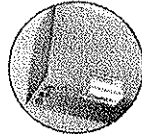

Enhanced LED Size
for Better Visibility
(SCS versions only)

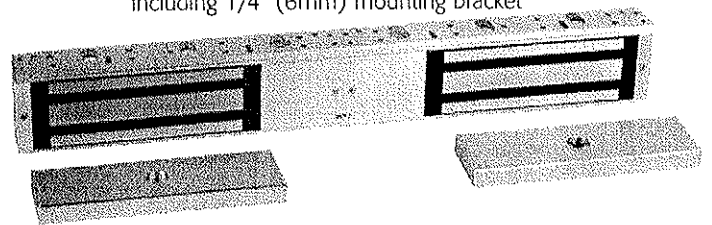

8320

Double outswinging
interior or perimeter doors without mullion
1-5/8"D x 2-7/8"W x 21"L
(41.3mm x 73.0mm x 533.4mm)
Including 1/4" (6mm) mounting bracket

Features & Benefits

- Enhanced LED size for better visibility (SCS versions only)
- Brushed Anodized Aluminum or Brushed Anodized Dark Bronze finish
- Adjustable keyhole mounting
- Built-in time delay (instant release with adjustable relock, programmable from 0-110 seconds)
- Field selectable voltage – 12/24VDC
- Convenient plug-in wiring terminals
- Easy-access wiring cavity
- Stabilizing 4-bolt "Drop Stop" mounting (8-bolt for 8320)
- MOV surge protection
- No residual magnetism
- Low energy consumption
- Hardened steel armature nut
- Self-drilling tek™ fasteners

Optional Mounting Accessories

- Angle Brackets
- Armature Plate Holders
- Filler Bars
- Glass Door Brackets
- Spacers
- Top Jamb "Z" Bracket Kits for Inswinging Doors (8310 Only – reduces holding force by half)
- Armature Bolts
- "L" Brackets
- DSS Retrofit Kit (order 2DSS for 8320)
- Split Armature Kit

MultiMag®

These hard-working multi-purpose electromagnetic locks enhance building security and install quickly. Several standard features make these magnets the "workhorse" of the industry.

The adjustable mounting bracket has been enhanced with keyhole mounting to support the magnet's weight during initial installation, freeing the installer's hands to affix the magnet mounting screws. The removable cavity cover offers quick, easy access to wiring.

Both models feature a built-in, adjustable time delay with instant unlock and de-layed relock (up to 110 seconds), which can be controlled by any standard switching device.

Options

- DSS**..... Door Status Sensor (Retrofit kits available)
- 2DSS**..... 2 Door Status Sensors for 8320 (Retrofit kits available)
- SCS**..... Security Condition Sensor
- 2SCS**..... 2 Security Condition Sensors for 8320
- DSS/SCS**..... Door Status Sensor / Security Condition Sensor Combination
- 2DSS/SCS**..... 2 Door Status Sensors / Security Condition Sensors Combination for 8320
- MCW8310 or MCW8320**..... Magnet Cover Wraps
- Special Finishes**..... Available only on Magnet Cover Wraps

Highlights

- Installer's "helping hand" mounting bracket
- Up to 1500 lbs. holding force
- Dual voltage
- Low-voltage detection (on SCS version)
- cULus Listed
- Lifetime Warranty

Applications

INTERIOR OR PERIMETER

- Single outswinging doors
- Single inswinging doors (use with Z bracket)
- Pairs of outswinging doors without mullion
- Pairs of inswinging doors without mullion (use with Z brackets)
- Government Facilities
- Office Complexes
- Warehouses
- Retail
- Commercial
- Industrial
- Health Care

Specifications

8310 

8320 



In or Out...we make it Easy!®

NOTE: Specifications are subject to change without notice.

Specifications	8310	
Housing Dimensions	1-5/8" D x 2-7/8" W x 10-1/2" L (41.3mm x 73.0mm x 266.7mm) (including 1/4" (6mm) mounting bracket)	1-5/8" D x 2-7/8" W x 21" L (41.3mm x 73.0mm x 533.4mm) (including 1/4" mounting (6mm) bracket)
Armature Plate Dimensions	Standard 5/8" D x 2-3/8" W x 7-7/16" L* (15.9 x 60.3 x 188.9mm) Optional 3/8" D x 2-3/8" W x 7-7/16" L* (9.5 x 60.3 x 188.9mm)	Standard 5/8" D x 2-3/8" W x 7-7/16" L* (15.9 x 60.3 x 188.9mm) Optional 3/8" D x 2-3/8" W x 7-7/16" L* (9.5 x 60.3 x 188.9mm)
Voltage	Field selectable 12/24 VDC Tolerance ±10%	Field selectable 12/24 VDC Tolerance ±10%
Power/Current Requirements	Max 0.28A at 12 VDC Max 0.28A at 24 VDC	Max 0.28A at 12 VDC (each lock) Max 0.28A at 24 VDC (each lock)
Holding Force	One-point locking (up to 1500 pounds)	Two-point locking (up to 1500 pounds each point)
Output Relays	SCS (with LED) – SPDT 1.25A @ 24VDC DSS – SPDT 0.20A @ 12VDC and 0.12A @ 24VDC	SCS (with LED) – SPDT 1.25A @ 24VDC DSS – SPDT 0.20A @ 12VDC and 0.12A @ 24VDC
Wiring Requirements	2 wires – power input Up to 4 wires output	2 or 4 wires – power input Up to 4 or 8 wires output
Adjustable Time Delay	0 to 110 seconds	0 to 110 seconds
Operating Temperature	-14 to 140° F (-10 to 60° C)	-14 to 140° F (-10 to 60° C)
Certification	cULus Listed, MEA, CSFM	cULus Listed, MEA, CSFM

*DSS armature plate dimensions are 5/8" D x 2-3/8" W x 10" L (15.9 x 60.3 x 254.0mm) and 3/8" D x 2-3/8" W x 10" L (9.5 x 60.3 x 254.0mm).
NOTE: RCI recommends frame reinforcement and our filtered, regulated DC voltage 10 Series power supplies.

Additional Features	
Security Condition Sensor (SCS)	Electronic field presence sensor for remote and local LED indication of lock status (locked or unlocked), reduced holding force caused by materials between magnet and plate, and unlocked device due to current loss.
Door Status Sensor (DSS)	Ceramic magnet-reed type sensor for remote indication of door status (opened or closed, independent of local power); magnet embedded in armature for tamper resistance; reed switch inside electronic housing cavity for easy access.
LED Indicator	Included on SCS options, the LED gives a local indication of lock status: red – unsecured; green – secured.
Low-Voltage Detection	Low voltage dramatically reduces electromagnetic lock holding force. This detection feature signals the SCS relay/LED to activate (alarm) when voltage drops below 10.3 VDC (12V input) or 20.5 VDC (24V input).

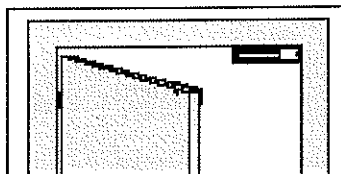

8310 Typical Installation

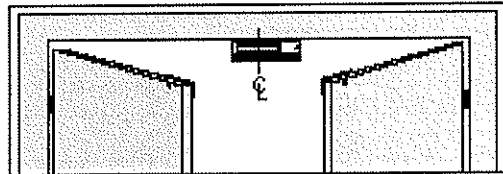

8310 Split Armature Installation

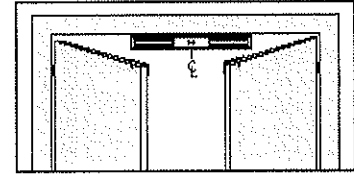

8320 Typical Installation

RCI also offers a complete line of Electromagnetic Locks, Electric Strikes, Power Supplies, Switches, Keypads & Readers, Exit Devices, Systems & Door Hardware.

M62FG-SASM

1200 lbs. Holding Force Gate Magnalock®

1200 lbs. holding force weatherproof face-mounted Magnalock with conduit fitting and automatic dual voltage. Shock Absorbing Strike Mount (SASM) controls excessive impact between the strike and the Magnalock, dramatically prolonging the life of the lock, gate and other hardware. SASM is available with the M62FG, or as an individual kit to retrofit existing M32, M62 or M82 Gate Magnalock installations. Recommended for high security perimeter fence gates and electrically operated sliding gates. Brackets shown not included.

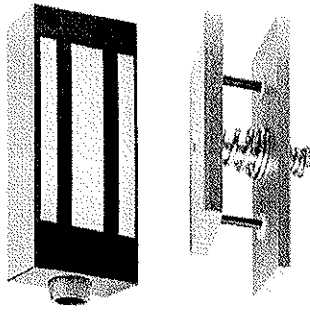

Features & Benefits

- Patented instant release circuit - no residual magnetism
- Fully sealed electronics - tamper proof and weatherproof
- Ten feet [3.05m] of jacketed, stranded conductor
- Automatic dual voltage - no field adjustment required
- Universal threaded conduit fitting is 1/2" female - 3/4" male
- SASM is a simple-to-install Stainless Steel parts kit
- SASM main spring provides 5/8" impact compression and 110 lbs resistance
- SASM anti-kickback spring provides 3/8" of rebound travel to return the gate to the normal "home" position

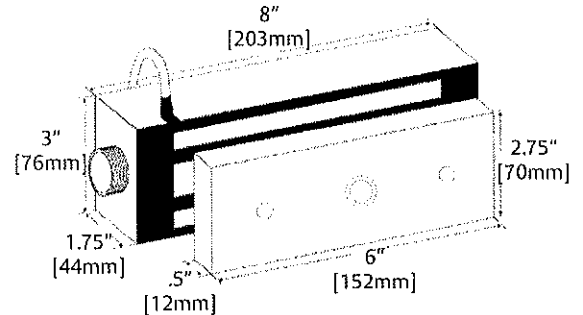

Specification Data

Holding Force: 1200 lbs. [544 Kg.]
 Current Draw and Voltage: 250mA at 12VDC; 125mA at 24VDC
 Operating Temperature: -40 to +140F [-40 to +60C]
 Shipping Weight: M62FG-SASM - 12 lbs.
 Warranty: MagnaCare Lifetime Replacement Warranty

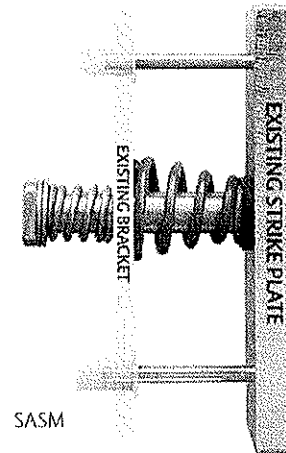

Stainless Steel parts kit retrofits any existing M32, M62 or M82 strike plate for superior impact absorption

How To Order

Part #	Description
M62FG-SASM	Model 62, Face Mount, Conduit with SASM
SASM	Shock Absorbing Strike Mount Kit

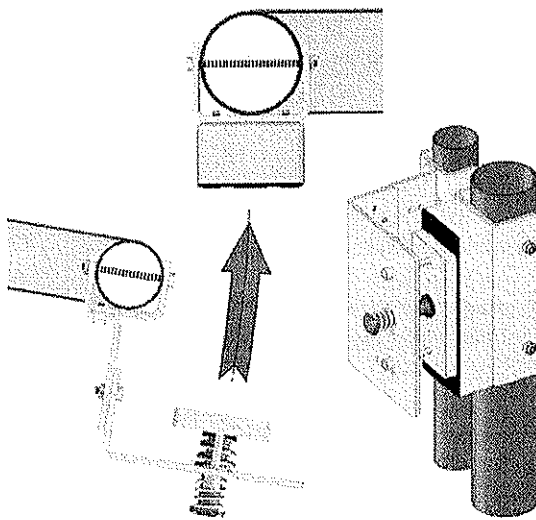

M62FG-SASM on Sliding Gate Using Flex-Mount Bracket Kit FMK-SL

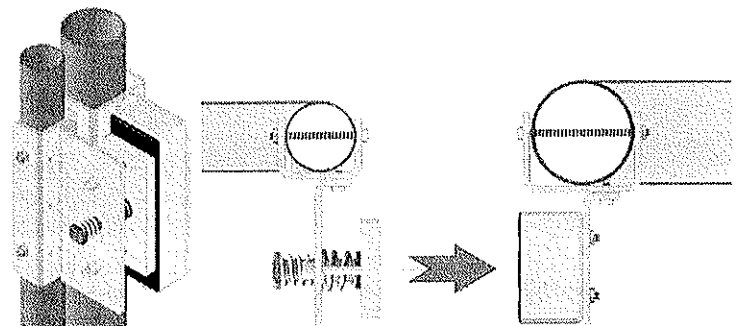

M62FG-SASM on Swinging Gate Using Flex-Mount Bracket Kit FMK-SW

See M62FG Mounting Brackets shown on page 25

Shock Absorbing Strike Mount Kit (SASM)

SECURITRON™
ASSA ABLOY

Extra Protection for "F" Type Gate Magnalocks

Designed to control excessive and potentially damaging physical impact between the armature and Magnalock in a variety of manual and electrically operated gate applications. This hardware kit easily covers any standard M32, M62 or M82 strike plate. Provides 1.125" of compression.

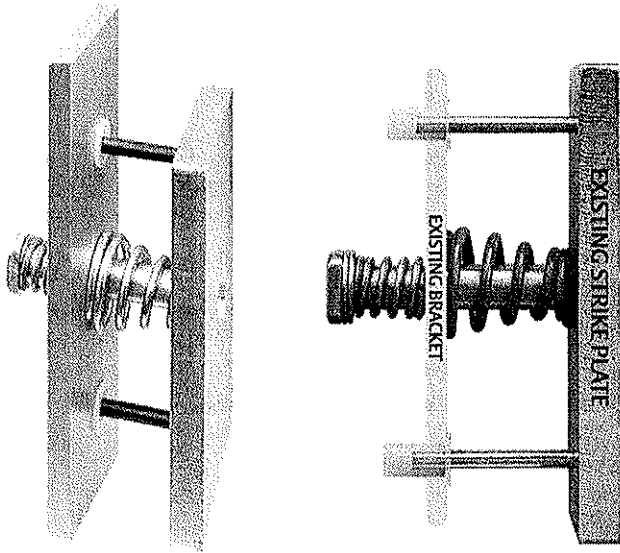
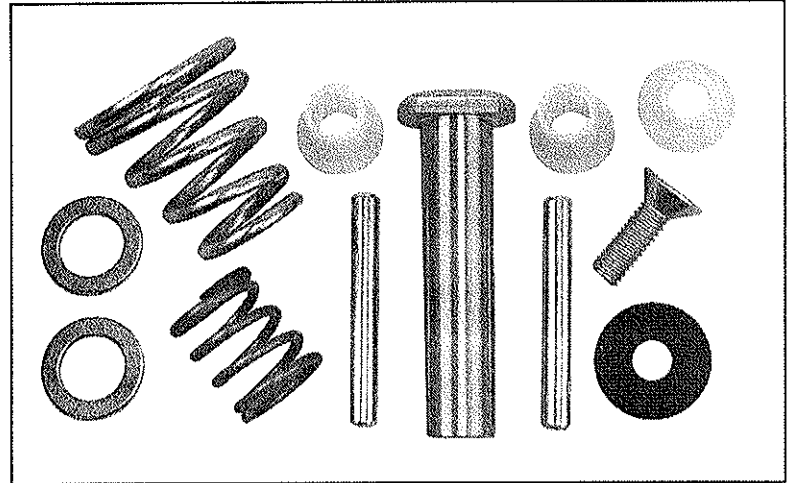

SASM

Stainless Steel parts kit retrofits any existing M32, M62 or M82 strike plate for superior impact absorption

How To Order

Part #	Description
M62FG-SASM	Model M62, Face Mount, Conduit with SASM
SASM	Shock Absorbing Strike Mount Kit

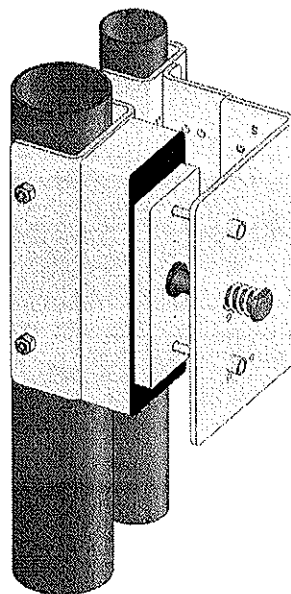

SASM on Swinging Gate Using Flex-Mount Bracket Kit FMK-SW

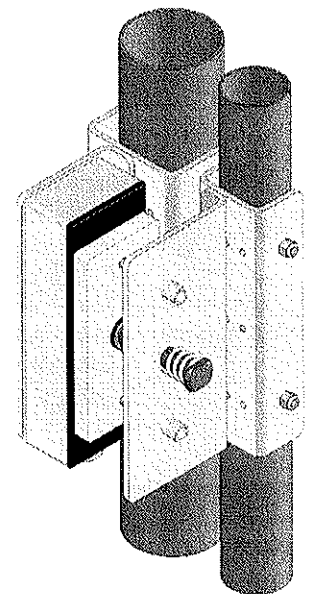

SASM on Sliding Gate Using Flex-Mount Bracket Kit FMK-SL

FMK

Flex-Mount Gate Lock Bracket Kits

The Flex Mount Bracket System is an intuitive set of mounting brackets designed exclusively for use with the 1200 lb. M62FG Magnalock® and the 2000 lb. GL1 Gate Lock. Using pre-formed post channels and plates of varying lengths, a professional looking high security gate lock mounting platform can be assembled in minutes without special tools.

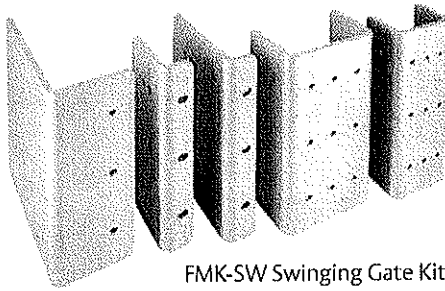

FMK-SW Swinging Gate Kit

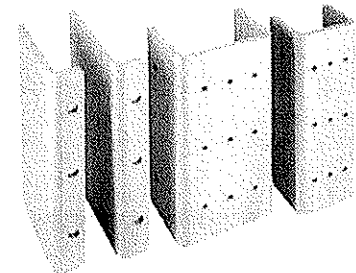

FMK-SL Sliding Gate Kit

Features & Benefits

- Pre-configured kits include all lock mounting hardware and post shims
- Post brackets are pre-drilled, lock and strike brackets are pre-tapped
- 8" tall x 3/16" thick zinc-plated steel provides durability and long life
- Lock and strike brackets are reversible doubling the mounting variations
- Allows simple bolt on installation, or the entire system can be welded
- Allows superior adjustability of lock and strike before final welding
- Permits electronics to be mounted on either the fence post or gate post

How To Order

Part #	Description
FMK-SL	Flex-Mount Bracket Kit, Sliding Gate
FMK-SW	Flex-Mount Bracket Kit, Swinging Gate
FMK9-4	Flex-Mount Post Shim Brackets (pkg of 4)

Post Shim Brackets are used to adapt both small and large Post Brackets to pole/post sizes smaller than 2" or 3" respectively in 1/8" increments - 1-7/8", 1-3/4", 1-5/8", 2-7/8", 2-3/4", etc.

When more than two shims are used together on a single post, welding the bracket to the pole/post is always recommended.

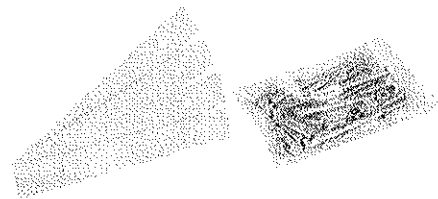

All necessary mounting hardware including four Post Shims is included with each Flex-Mount kit

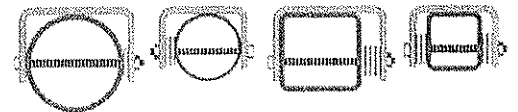
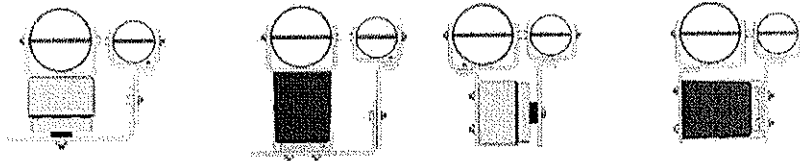

Post Shim Brackets Installed

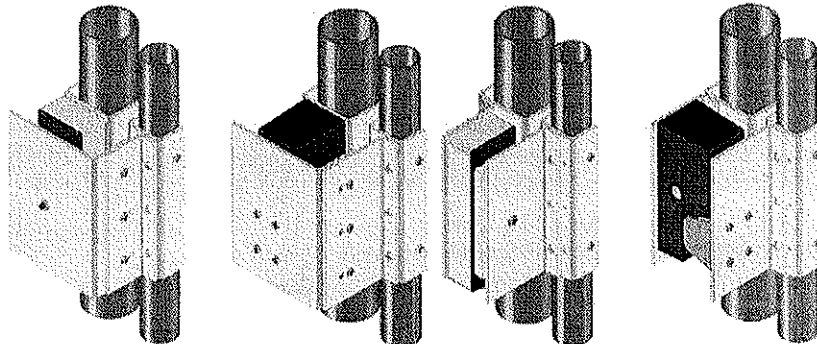

Flex-Mount Swinging Application

Flex-Mount Sliding Application

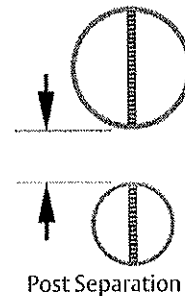

Post Separation

Notes

- **FMK-SL** will function with GL1 when post separation is between 1" and 3-3/4"
- **FMK-SL** will function with M62FG when post separation is between 1" and 2-1/4" when using Shock Absorbing Strike Mount (SASM)
- **FMK-SL** will function with M62FG when post separation is between 1" and 3-3/4" without SASM
- **FMK-SW** will function with either the M62FG or the GL1 when post separation is between 1" and 2-3/4"

Flex-Mount Brackets are Available Individually for Specialized Applications - Contact Technical Support

TOSHIBA
Leading Innovation >>>

DVS/XVS Series
Digital Video Recorders

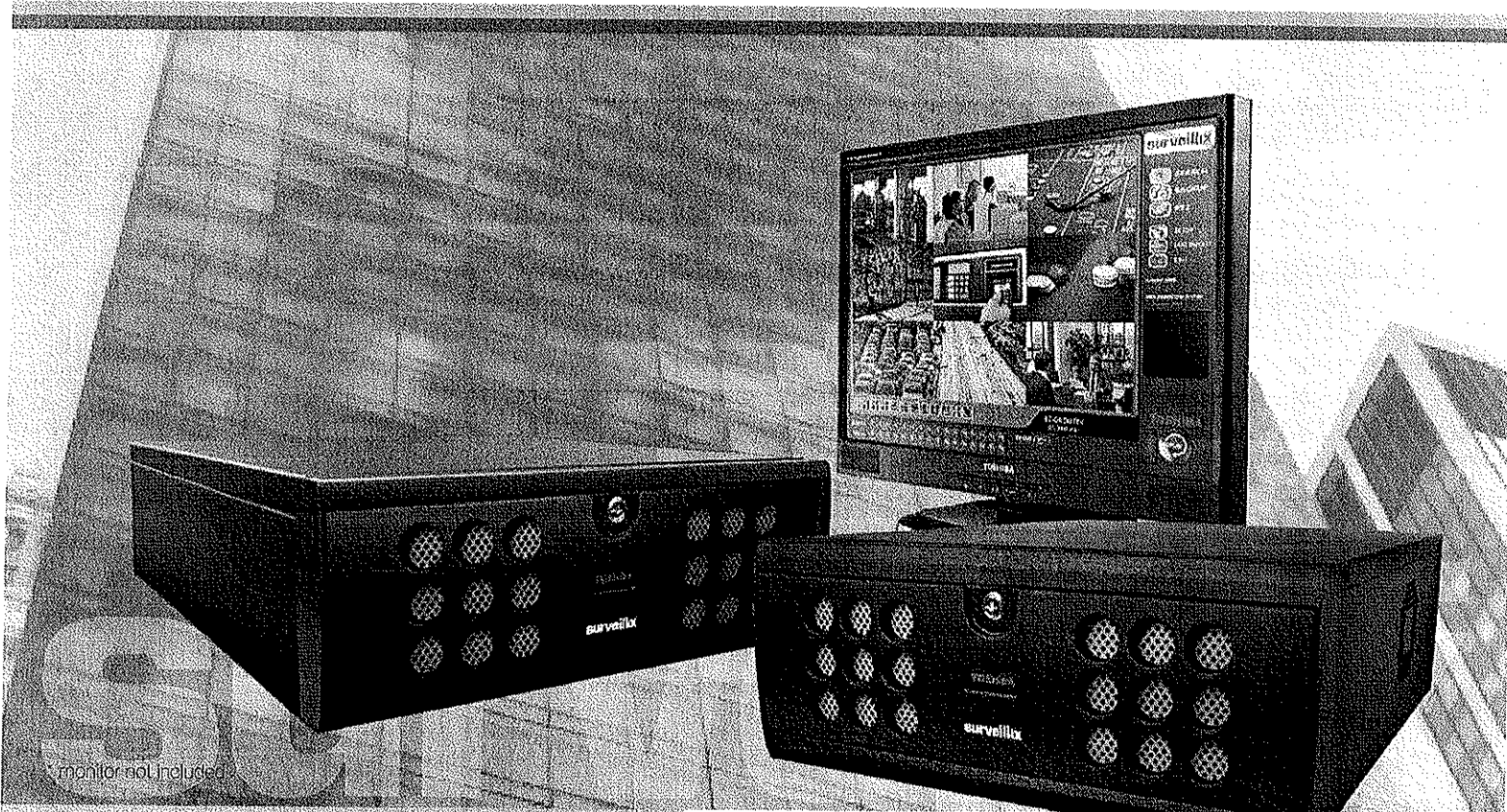

monitor not included

120/240/480 PPS

4/8/16/32
CHANNELS

Up to 480 PPS
16 channels per camera

4 CH. HYBRID
Standard on ALL DVRs

Advanced Digital Recording

- 4 Hybrid Recording Channels Standard on All DVRs
- Supports H.264, MPEG-4, MJPEG compression codecs.
- Available in 4, 8, 16 and 32 channel configurations.
- 120/240/480 PPS recording. (Up to 30 PPS per camera.)
- Up to 8 TB internal RAID 5 available.
- Removable HDD bays for quick HDD replacement and field upgrades.
- Dual monitor support on all systems.
- Multi-Site SCS software. The SCS software remotely manages 100+ DVRs allowing you to configure, view, search, export, remotely upgrade, and monitor alarms. Supports multiple monitors.

DVS Series

Digital Video Recorders

With available Internal RAID 5 capabilities and field replaceable Hard Disk Drives, the DVS Series is designed for maximum reliability. The DVS Series comes pre-configured to allow HDD storage expansion in the field without it needing to be returned to Toshiba for upgrading. Capable of recording at speeds of up to 480 pictures per second, the DVS offers unmatched versatility.

	240			480	
	8CH	16CH	32CH	16CH	32CH
Video Format	NTSC/PAL				
Analog Video Inputs (max)	8	16	32	16	32
IP Video Inputs	4 standard (Up to 16 Ch. max.)				
Video Outputs	DVI-D x 1, SVGA x 1 (Primary Display), RCA x 1 (Spot Monitor)				
Looping Outputs (BNC)	8	16	32	16	32
Recording Rate	240 PPS 360x240 120 PPS 720x240 60 PPS 720x480		480 PPS 360x240 240 PPS 720x240 120 PPS 720x480		
Live Viewing Rate (PPS)	240	480		480	
Audio Recording <small>Requires Network Interface</small>	4 (6ch)	4 (6ch)	8 (6ch)	16 (6ch)	8 (6ch)
Sensor/Alarm Inputs	8	16	16	16	16
Alarm Outputs	8	16	16	16	16
PTZ Controls	Internal RS-422/485 (over 75 protocols)				
Image Compression	MJPEG, H.264, MPEG-4				
Storage Capacity	Up to 8 Terabytes (RAID 5 optional)				
LAN	100/1000 Gigabit Ethernet				
Critical Recording Archive	DVD Multi Burner, Network, USB				
Password Control	User Defined Access Level				
Power Interruption Recovery	Automatic restart after power interruption/ recording operation resumes				
Remote Connection	TCP/IP, UDP, Internet, LAN, WAN				
Power Input	AC 100-240V Input (50 Hz/60 Hz)				
Central Processing Unit	Intel® Dual Core 2 Ghz+		Intel® Core™2 Duo 2 Ghz+		
RAM	1 GB				
Operating System	Microsoft® Windows® XP Embedded				
Dimensions (h x w x d)	7" x 17.3" x 21.75" (180mm x 440mm x 562mm)				
Weight	47-62 lbs (21.3-23.5 kg) 67 - 84 lbs (29-38 kg) with packaging				

*IP Video Inputs may not exceed the number of Analog Video Inputs

XVS Series

Digital Video Recorders

With intuitive setup menus, easy to configure recording schedules, and 6 intelligent search options, XVS series DVRs are a hassle free solution for your recording needs.

XVS systems come equipped with up to 4 Terabyte internal storage, recording speeds up to 240 pictures per second, looping video outputs, and a DVD+RW standard.

	4CH	16CH	16CH
	120PPS	240VPPS	240PPS
Video Format	NTSC/PAL		
Video Inputs (BNC)	4	16	16
IP Video Inputs	4 standard (Up to 16 Ch. max.)		
Video Outputs	DVI-D x 1, SVGA x 1 (Primary Display), RCA x 1 (Spot Monitor)		
Looping Outputs	0	16 (BNC)	16 (BNC)
Recording Rate	120 PPS 360x240 120 PPS 720x240 60 PPS 720x480	240 PPS 360x240 120 PPS 720x240 60 PPS 720x480	240 PPS 360x240 120 PPS 720x240 60 PPS 720x480
Live Viewing Rate	120 PPS	240 PPS	480 PPS
Audio Recording	RCA x 4	RCA x 2	RCA x 4
Sensor/Alarm Inputs	4 (NO/NC)	16 (NO/NC)	16 (NO/NC)
Alarm Outputs	4	4	4
PTZ Controls	Internal RS-422/485 (over 75 protocols)		
Image Compression	MJPEG, H.264, MPEG-4		
Storage Capacity	Up to 4 Terabytes		
LAN	100/1000 Gigabit Ethernet		
Critical Recording Archive	DVD Multi Burner, Network, USB		
Password Control	User Defined Access Level		
Power Interruption Recovery	Automatic restart after power interruption/ recording operation resumes		
Remote Connection	TCP/IP, UDP, Internet, LAN, WAN		
Power Input	AC 100-240V Input (50 Hz/60 Hz)		
Central Processing Unit	Intel® Pentium® Dual Core 2 Ghz+		
RAM	1 GB		
Operating System	Microsoft® Windows® XP Embedded		
Dimensions (h x w x d)	5.8" x 17.25" x 19.5" (148mm x 438mm x 495mm)		
Weight	30-33 lbs (13.6-15 kg) 40-43 lbs (18-19.5 kg) with packaging		

*IP Video Inputs may not exceed the number of Analog Video Inputs

DVS SERIES PART NUMBERS

4U MULTI CODEC RECORDERS

DVS32-480-500G/1T/2T/3T/4T/6T/8T
 DVS32-240-500G/1T/2T/3T/4T/6T/8T
 DVS16-480-1T/2T/3T/4T/6T/8T
 DVS16-240-500G/1T/2T/3T/4T/6T/8T
 DVS8-240-500G/1T/2T/4T

OPTIONAL ACCESSORIES FOR DVS

- Internal RAID5 (DVR-RS)
- Additional Hard Drives (1TB: HDD-1TB, 2TB: HDD-2TB)
- Redundant Power Supply (2-RDNT-PS)
- 16CH Audio Card (16-AUD)
- Extended Warranties (EW-S3Y/S4Y/S5Y)

For more information, contact your sales representative.

XVS SERIES PART NUMBERS

3U MULTI-CODEC RECORDERS

XVS16-240V-500G/1T/2T/4T
 XVS16-240-500G/1T/2T/4T
 XVS4-120-500G/1T/2T/4T

OPTIONAL ACCESSORIES FOR XVS

- Extended Warranties (EW-S3Y/S4Y/S5Y)

For more information, contact your sales representative.



EHD650

Wide Dynamic Range, True Day/Night
Vandal Color Dome Camera

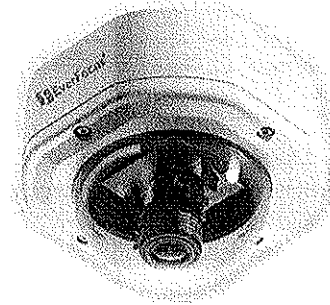
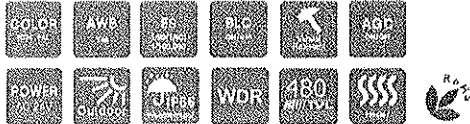

Features

- 1/3" Pixim Digital Pixel System (DPS)
- 480 TVL of horizontal resolution
- Each pixel is processed independently, providing high quality images with enhanced dynamic range under extreme lighting conditions
- Superior Wide Dynamic image quality: Film-like colors are illustrated under various light conditions, even in high dynamic range scenes (>120dB max)
- True Day/Night with IR cut filter
- Vandal resistant: designed with polycarbonate shell to withstand the impact of a 10 lb sledgehammer
- Weatherproof IP66 rated to endure all weather conditions

Specifications

Pickup Device	1/3" Pixim Digital Pixel System
Pixel Element	720 x 540 (Digital)
Horizontal Resolution	480 TVL (Analog)
Sensitivity	0.08 Lux / F=1.2 (DSS x 36)
Slow Shutter	Up to 32x (2, 4, 8, 16, 32)
S/N Ratio	Over 48dB
Auto Exposure	Yes
Auto White Balance	Yes, 2500K ~9500K (Adjustable)
Backlight Comp.	Yes
Auto Iris	Yes
Video Output	BNC, 1.0Vp-p / 75 ohm
Auto Gain Control	Yes (max. 38dB)
Wide Dynamic Range	95dB typical, 120dB max
Sync. Mode	Line Lock/Internal Sync.
Image Flip	Yes (Horizontal Reverse)
On Screen Display	Yes
Lens	f=2.9~10mm
Power Source	24VAC
Operating Temp.	-40°C ~ 50°C / -40°F ~ 122°F (20% ~ 80% Humidity)
Power Consumption	4.5W max. (w/out heater) 15W max. (w/heater)
Dimensions (W x H x D)	130 x 98.9 x 130 mm / 5.1" x 3.9" x 5.1"

Dimensions

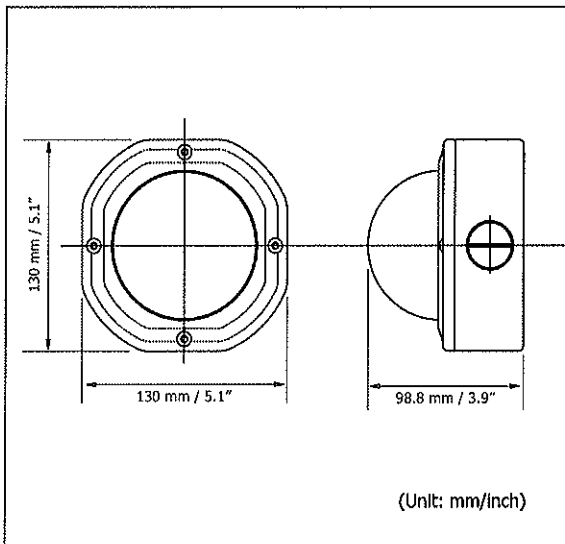

Ordering Information

- **EHD650/H-3:** 1/3" Wide Dynamic, True Day/Night Rugged Vandal Dome Color Camera, 2.9~10mm Lens

*Models vary in different countries. Please visit your EverFocus regional website for detailed ordering information.

EHD650

Wide Dynamic Range, True Day/Night
Vandal Color Dome Camera

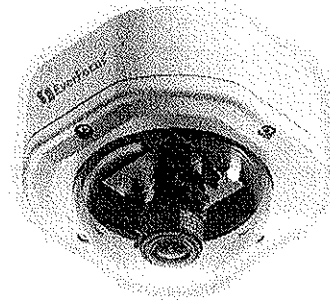
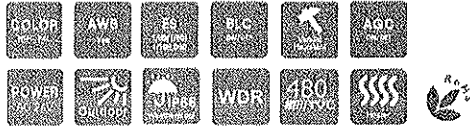

Features

- 1/3" Pixim Digital Pixel System (DPS)
- 480 TVL of horizontal resolution
- Each pixel is processed independently, providing high quality images with enhanced dynamic range under extreme lighting conditions
- Superior Wide Dynamic image quality: Film-like colors are illustrated under various light conditions, even in high dynamic range scenes (>120dB max)
- True Day/Night with IR cut filter
- Vandal resistant: designed with polycarbonate shell to withstand the impact of a 10 lb sledgehammer
- Weatherproof IP66 rated to endure all weather conditions

Specifications

Pickup Device	1/3" Pixim Digital Pixel System
Pixel Element	720 x 540 (Digital)
Horizontal Resolution	480 TVL (Analog)
Sensitivity	0.08 Lux / F=1.2 (DSS x 36)
Slow Shutter	Up to 32x (2, 4, 8, 16, 32)
S/N Ratio	Over 48dB
Auto Exposure	Yes
Auto White Balance	Yes, 2500K ~9500K (Adjustable)
Backlight Comp.	Yes
Auto Iris	Yes
Video Output	BNC, 1.0Vp-p / 75 ohm
Auto Gain Control	Yes (max. 38dB)
Wide Dynamic Range	95dB typical, 120dB max
Sync. Mode	Line Lock/Internal Sync.
Image Flip	Yes (Horizontal Reverse)
On Screen Display	Yes
Lens	f=2.9~10mm
Power Source	24VAC
Operating Temp.	-40°C ~ 50°C / -40°F ~ 122°F (20% ~ 80% Humidity)
Power Consumption	4.5W max. (w/out heater) 15W max. (w/heater)
Dimensions (W x H x D)	130 x 98.9 x 130 mm / 5.1" x 3.9" x 5.1"

Dimensions

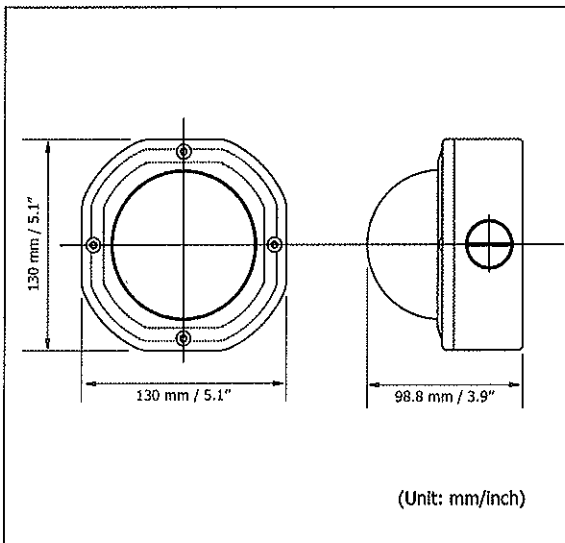

Ordering Information

- **EHD650/H-3:** 1/3" Wide Dynamic, True Day/Night Rugged Vandal Dome Color Camera, 2.9~10mm Lens

*Models vary in different countries. Please visit your EverFocus regional website for detailed ordering information.



ALTV248175, ALTV248175CB AC CCTV Power Supply

Rev. DSALTV248175 - A09F

Overview

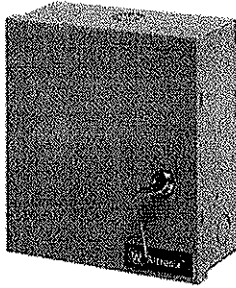

- These Altronix AC Wall Mount CCTV Power Supplies provide provide 24VAC or 28VAC distributed via eight (8) fuse or PTC protected outputs for powering CCTV Cameras, heaters and other video accessories.

ALTV248175

- Eight (8) fuse protected outputs.
- Outputs are rated @ 3.5 amp.

ALTV248175CB

- Eight (8) PTC protected outputs.
- Outputs are rated @ 2.5 amp.

Specifications

- Input 115VAC, 50/60Hz, 1.5 amp.
- 24VAC @ 7.25 amp (175VA) or 28VAC @ 6.25 amp (175VA) supply current.
- Main fuse rated @ 10 amp/250V.
- Illuminated master power switch with built-in circuit breaker.
- Surge suppression.

- AC power LED.
- Spare fuse(s) provided (all models w/primary and/or secondary fuses).
- Unit maintains camera synchronization.
- Ease of installation saves time and eliminates costly labor.

Agency Approvals

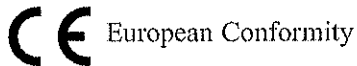

Enclosure Dimensions

8.5"H x 7.5"W x 3.5"D

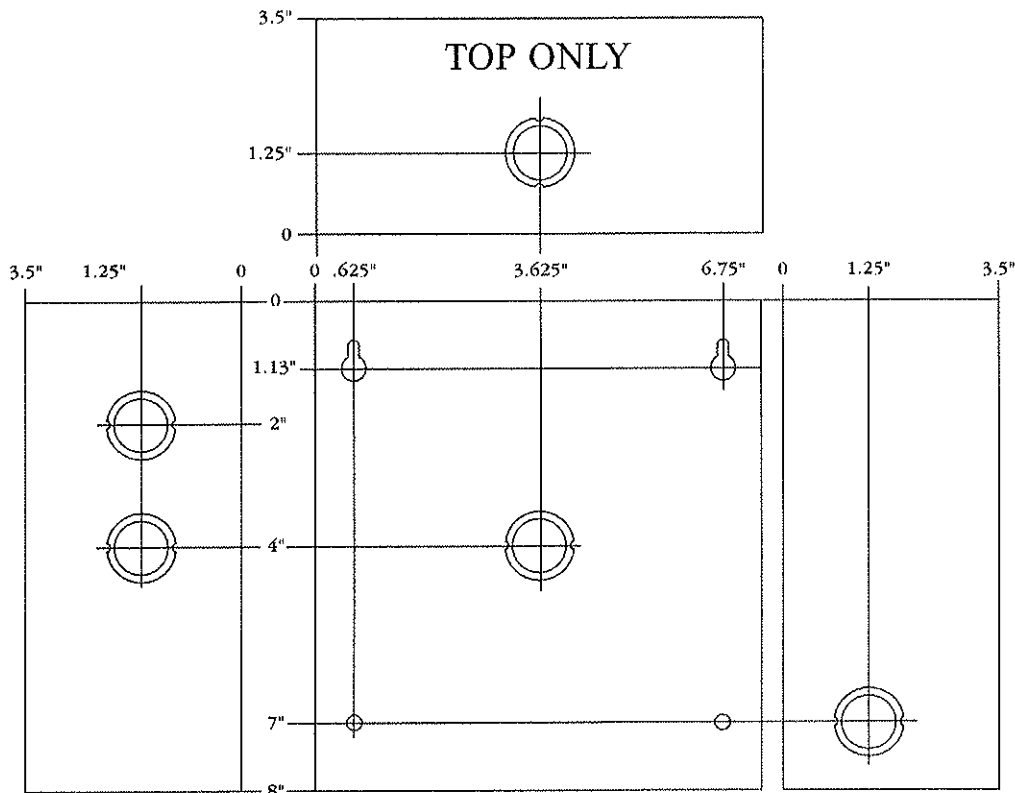

COST SHEET FOR ACCESS CONTROL SYSTEM

MMB11028

Mildred Mitchell-Bateman Hospital, Huntington, WV

Keyscan & Toshiba

Vendor offers completion of the specifications detailed by this RFQ for the following bid price:

EQUIPMENT	Quantity	UNIT PRICE	TOTAL AMOUNT BID
Hardware server, complete	1	3000.00	3000.00
Workstations	4	960.00	3,840.00
Proximity card readers	45	132.00	5940.00
Electronic door hardware	31	<i>new code below</i>	
Surveillance cameras	31	34,003.24	34,003.24
Magnetic door locks	31	213.76	6,626.44
Hardware for Access Card preparation	1	5,831.08	
Program Interface	1		
Operational Interface	1		
			5,831.08
OTHER COSTS			
Access Control System software	1	1,730.62	1,730.62
Software for preparation of access cards for staff	1		
Installation cost of hardware and software	1	50,221.28	50,221.28
Battery backup	1	1,133.20	1,133.20
Two (2) year warranty for software, hardware, labor and parts.	2	<i>Included in installation cost</i>	
Training cost	3	0	0
Access Card supplies	1000	3.48	3,480.00

ALL CCTV EQUIP

GRAND TOTAL **\$115,870.86**

Submitted by Vendor on 6 day of Jan, 2010.

[Signature]
Vendors Representative signature

Owner / President
Representatives Title

*above break out does not represent how the systems where assemble. A detailed breakout can be provided on request.
Grand Total does represent total cost.*

BID BOND

KNOW ALL MEN BY THESE PRESENTS, That we, the undersigned, Long's Security Camera Systems, LLC
of 102 38th Street SE, Charleston, WV 25304, as Principal, and Western Surety Company
of Sioux Falls, South Dakota, a corporation organized and existing under the laws of the State of
South Dakota with its principal office in the City of Sioux Falls, as Surety, are held and firmly bound unto the State
of West Virginia, as Obligee, in the penal sum of Five Percent (5%) of Amount Bid (\$) for the payment of which,
well and truly to be made, we jointly and severally bind ourselves, our heirs, administrators, executors, successors and assigns.

The Condition of the above obligation is such that whereas the Principal has submitted to the Purchasing Section of the
Department of Administration a certain bid or proposal, attached hereto and made a part hereof, to enter into a contract in writing for
Card Access and CCTV at Mildred Mitchell-Bateman Hospital
Huntington, West Virginia (MMB11028)

NOW THEREFORE,

(a) If said bid shall be rejected, or
(b) If said bid shall be accepted and the Principal shall enter into a contract in accordance with the bid or proposal attached
hereto and shall furnish any other bonds and insurance required by the bid or proposal, and shall in all other respects perform the
agreement created by the acceptance of said bid, then this obligation shall be null and void, otherwise this obligation shall remain in full
force and effect. It is expressly understood and agreed that the liability of the Surety for any and all claims hereunder shall, in no event,
exceed the penal amount of this obligation as herein stated.

The Surety, for the value received, hereby stipulates and agrees that the obligations of said Surety and its bond shall be in no
way impaired or affected by any extension of the time within which the Obligee may accept such bid, and said Surety does hereby
waive notice of any such extension.

IN WITNESS WHEREOF, Principal and Surety have hereunto set their hands and seals, and such of them as are corporations
have caused their corporate seals to be affixed hereunto and these presents to be signed by their proper officers, this
6th day of January, 2011.

Principal Corporate Seal

Long's Security Camera Systems, LLC
(Name of Principal)
By [Signature]
(Must be President or
Vice President)
[Signature]
(Title)

Surety Corporate Seal

Western Surety Company
(Name of Surety)
By [Signature]
Donna J. Price Attorney-in-Fact
Licensed West Virginia Resident Agent

IMPORTANT - Surety executing bonds must be licensed in West Virginia to transact surety insurance. Corporate seals must be affixed,
and a power of attorney must be attached.

copy original in other Bid Package

POWER OF ATTORNEY APPOINTING INDIVIDUAL ATTORNEY-IN-FACT

Know All Men By These Presents, That WESTERN SURETY COMPANY a South Dakota corporation is a duly organized and existing corporation having its principal office in the City of Sioux Falls, and State of South Dakota and that it does by virtue of the signature and seal herein affixed hereby make, constitute and appoint

Andrew K Teeter, Janis K Peacock, Kimberly L Miles, Douglas P Taylor, Donna J Price, Individually

of Charleston, WV, its true and lawful Attorney(s)-in-Fact with full power and authority hereby conferred to sign, seal and execute for and on its behalf bonds, undertakings and other obligatory instruments of similar nature

- In Unlimited Amounts -

and to bind it thereby as fully and to the same extent as if such instruments were signed by a duly authorized officer of the corporation and all the acts of said Attorney, pursuant to the authority hereby given, are hereby ratified and confirmed

This Power of Attorney is made and executed pursuant to and by authority of the By-Law printed on the reverse hereof, duly adopted, as indicated, by the shareholders of the corporation.

In Witness Whereof, WESTERN SURETY COMPANY has caused these presents to be signed by its Senior Vice President and its corporate seal to be hereto affixed on this 19th day of March, 2010



WESTERN SURETY COMPANY

Handwritten signature of Paul T. Bruffat

Paul T. Bruffat, Senior Vice President

State of South Dakota }
County of Minnehaha }

ss

On this 19th day of March, 2010, before me personally came Paul T. Bruffat, to me known, who, being by me duly sworn, did depose and say that he resides in the City of Sioux Falls, State of South Dakota; that he is the Senior Vice President of WESTERN SURETY COMPANY described in and which executed the above instrument, that he knows the seal of said corporation; that the seal affixed to the said instrument is such corporate seal, that it was so affixed pursuant to authority given by the Board of Directors of said corporation and that he signed his name thereto pursuant to like authority, and acknowledges same to be the act and deed of said corporation

My commission expires

November 30, 2012

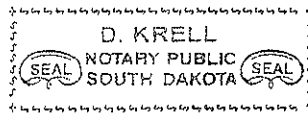

Handwritten signature of D. Krell

D. Krell, Notary Public

CERTIFICATE

I, L. Nelson, Assistant Secretary of WESTERN SURETY COMPANY do hereby certify that the Power of Attorney hereinabove set forth is still in force, and further certify that the By-Law of the corporation printed on the reverse hereof is still in force. In testimony whereof, I have hereunto subscribed my name and affixed the seal of the said corporation this 6th day of January 2011



WESTERN SURETY COMPANY

Handwritten signature of L. Nelson

L. Nelson, Assistant Secretary

ACORD CERTIFICATE OF LIABILITY INSURANCE

DATE (MM/DD/YY)

1/05/11

PRODUCER

Wells Fargo Ins. Services
of West Virginia, Inc.
P.O. Box 1551
Charleston WV 25326-1551
(304) 346-0611

THIS CERTIFICATE IS ISSUED AS A MATTER OF INFORMATION ONLY AND CONFERS NO RIGHTS UPON THE CERTIFICATE HOLDER. THIS CERTIFICATE DOES NOT AMEND, EXTEND OR ALTER THE COVERAGE AFFORDED BY THE POLICIES BELOW.

COMPANIES AFFORDING COVERAGE

COMPANY

A Landmark American Insurance Co

COMPANY

B

COMPANY

C

COMPANY

D

INSURED

Long's Security Camera Systems
102 38th St SE
Charleston, WV 25304

COVERAGES

THIS IS TO CERTIFY THAT THE POLICIES OF INSURANCE LISTED BELOW HAVE BEEN ISSUED TO THE INSURED NAMED ABOVE FOR THE POLICY PERIOD INDICATED, NOTWITHSTANDING ANY REQUIREMENT, TERM OR CONDITION OF ANY CONTRACT OR OTHER DOCUMENT WITH RESPECT TO WHICH THIS CERTIFICATE MAY BE ISSUED OR MAY PERTAIN, THE INSURANCE AFFORDED BY THE POLICIES DESCRIBED HEREIN IS SUBJECT TO ALL THE TERMS, EXCLUSIONS AND CONDITIONS OF SUCH POLICIES. LIMITS SHOWN MAY HAVE BEEN REDUCED BY PAID CLAIMS.

CC LTR	TYPE OF INSURANCE	POLICY NUMBER	POLICY EFFECTIVE DATE (MM/DD/YY)	POLICY EXPIRATION DATE (MM/DD/YY)	LIMITS
A	GENERAL LIABILITY	LBA064826	3/11/10	3/11/11	GENERAL AGGREGATE \$ 2,000,000
X	COMMERCIAL GENERAL LIABILITY				PRODUCTS-COMP/OP AGG \$ 2,000,000
	CLAIMS MADE <input checked="" type="checkbox"/> OCCUR				PERSONAL & ADV INJURY \$ 1,000,000
	OWNER'S & CONTRACTOR'S PROI				EACH OCCURRENCE \$ 1,000,000
					FIRE DAMAGE (Any one fire) \$ 100,000
					MED EXP (Any one person) \$ 5,000
	AUTOMOBILE LIABILITY				COMBINED SINGLE LIMIT \$
	ANY AUTO				BODILY INJURY (Per person) \$
	ALL OWNED AUTOS				BODILY INJURY (Per accident) \$
	SCHEDULED AUTOS				PROPERTY DAMAGE \$
	HIRED AUTOS				
	NON-OWNED AUTOS				
	GARAGE LIABILITY				AUTO ONLY - EA ACCIDENT \$
	ANY AUTO				OTHER THAN AUTO ONLY
					EACH ACCIDENT \$
					AGGREGATE \$
	EXCESS LIABILITY				EACH OCCURRENCE \$
	UMBRELLA FORM				AGGREGATE \$
	OTHER THAN UMBRELLA FORM				\$
	WORKERS COMPENSATION AND EMPLOYERS' LIABILITY				WC STATUTORY LIMITS OTH-ER
	THE PROPRIETOR/PARTNERS/EXECUTIVE OFFICERS ARE: <input type="checkbox"/> INCL <input type="checkbox"/> EXCL				EL EACH ACCIDENT \$
					EL DISEASE-POLICY LIMIT \$
					EL DISEASE-EA EMPLOYEE \$
	OTHER				

DESCRIPTION OF OPERATIONS/LOCATIONS/VEHICLES/SPECIAL ITEMS

RE: Card Access and CCTV at Mildred Mitchell-Bateman Hospital, Huntington, WV

CERTIFICATE HOLDER

State of WV
Health & Human Resources
State Capitol Complex Bldg 3
Room 206
Charleston, WV 25305

CANCELLATION

SHOULD ANY OF THE ABOVE DESCRIBED POLICIES BE CANCELLED BEFORE THE EXPIRATION DATE THEREOF, THE ISSUING COMPANY WILL ENDEAVOR TO MAIL 10 DAYS WRITTEN NOTICE TO THE CERTIFICATE HOLDER NAMED TO THE LEFT, BUT FAILURE TO MAIL SUCH NOTICE SHALL IMPOSE NO OBLIGATION OR LIABILITY OF ANY KIND UPON THE COMPANY, ITS AGENTS OR REPRESENTATIVES.

AUTHORIZED REPRESENTATIVE

Tammy Bowles

Tammy Bowles

© ACORD CORPORATION 1988

IMPORTANT

If the certificate holder is an ADDITIONAL INSURED, the policy(ies) must be endorsed. A statement on this certificate does not confer rights to the certificate holder in lieu of such endorsement(s).

If SUBROGATION IS WAIVED, subject to the terms and conditions of the policy, certain policies may require an endorsement. A statement on this certificate does not confer rights to the certificate holder in lieu of such endorsement(s).

DISCLAIMER

The Certificate of Insurance on the reverse side of this form does not constitute a contract between the issuing insurer(s), authorized representative or producer, and the certificate holder, nor does it affirmatively or negatively amend, extend or alter the coverage afforded by the policies listed thereon.

RFQ No. mmB11028

STATE OF WEST VIRGINIA
Purchasing Division

PURCHASING AFFIDAVIT

West Virginia Code §5A-3-10a states: No contract or renewal of any contract may be awarded by the state or any of its political subdivisions to any vendor or prospective vendor when the vendor or prospective vendor or a related party to the vendor or prospective vendor is a debtor and the debt owed is an amount greater than one thousand dollars in the aggregate.

DEFINITIONS:

"Debt" means any assessment, premium, penalty, fine, tax or other amount of money owed to the state or any of its political subdivisions because of a judgment, fine, permit violation, license assessment, defaulted workers' compensation premium, penalty or other assessment presently delinquent or due and required to be paid to the state or any of its political subdivisions, including any interest or additional penalties accrued thereon.

"Debtor" means any individual, corporation, partnership, association, limited liability company or any other form or business association owing a debt to the state or any of its political subdivisions. "Political subdivision" means any county commission; municipality; county board of education; any instrumentality established by a county or municipality; any separate corporation or instrumentality established by one or more counties or municipalities, as permitted by law; or any public body charged by law with the performance of a government function or whose jurisdiction is coextensive with one or more counties or municipalities. "Related party" means a party, whether an individual, corporation, partnership, association, limited liability company or any other form or business association or other entity whatsoever, related to any vendor by blood, marriage, ownership or contract through which the party has a relationship of ownership or other interest with the vendor so that the party will actually or by effect receive or control a portion of the benefit, profit or other consideration from performance of a vendor contract with the party receiving an amount that meets or exceeds five percent of the total contract amount.

EXCEPTION: The prohibition of this section does not apply where a vendor has contested any tax administered pursuant to chapter eleven of this code, workers' compensation premium, permit fee or environmental fee or assessment and the matter has not become final or where the vendor has entered into a payment plan or agreement and the vendor is not in default of any of the provisions of such plan or agreement.

Under penalty of law for false swearing (*West Virginia Code §61-5-3*), it is hereby certified that the vendor affirms and acknowledges the information in this affidavit and is in compliance with the requirements as stated.

WITNESS THE FOLLOWING SIGNATURE

Vendor's Name: Longs Security Camera Systems LLC

Authorized Signature: [Signature] Date: _____

State of WEST VIRGINIA

County of KANAWHA, to-wit:

Taken, subscribed, and sworn to before me this 6 day of JAN, 2011.

My Commission expires 3/31/2015, 20 .

AFFIX SEAL HERE

NOTARY PUBLIC [Signature]

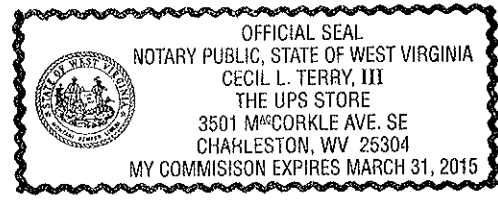

ATTACHMENT
P.O.# mmB11028

This agreement constitutes the entire agreement between the parties, and there are no other terms and conditions applicable to the licenses granted hereunder.

Agreed

Alan C. Smith 6-11
Signature Date

Owner
Title

Lang's Security Camera Systems
Company Name

Signature Date

Title

Agency/Division

WV-96
Rev. 10/07

AGREEMENT ADDENDUM

In the event of conflict between this addendum and the agreement, this addendum shall control:

1. **DISPUTES** - Any references in the agreement to arbitration or to the jurisdiction of any court are hereby deleted. Disputes arising out of the agreement shall be presented to the West Virginia Court of Claims.
2. **HOLD HARMLESS** - Any clause requiring the Agency to indemnify or hold harmless any party is hereby deleted in its entirety.
3. **GOVERNING LAW** - The agreement shall be governed by the laws of the State of West Virginia. This provision replaces any references to any other State's governing law.
4. **TAXES** - Provisions in the agreement requiring the Agency to pay taxes are deleted. As a State entity, the Agency is exempt from Federal, State, and local taxes and will not pay taxes for any Vendor including individuals, nor will the Agency file any tax returns or reports on behalf of Vendor or any other party.
5. **PAYMENT** - Any references to prepayment are deleted. Payment will be in arrears.
6. **INTEREST** - Should the agreement include a provision for interest on late payments, the Agency agrees to pay the maximum legal rate under West Virginia law. All other references to interest or late charges are deleted.
7. **RECOUPMENT** - Any language in the agreement waiving the Agency's right to set-off, counterclaim, recoupment, or other defense is hereby deleted.
8. **FISCAL YEAR FUNDING** - Service performed under the agreement may be continued in succeeding fiscal years for the term of the agreement, contingent upon funds being appropriated by the Legislature or otherwise being available for this service. In the event funds are not appropriated or otherwise available for this service, the agreement shall terminate without penalty on June 30. After that date, the agreement becomes of no effect and is null and void. However, the Agency agrees to use its best efforts to have the amounts contemplated under the agreement included in its budget. Non-appropriation or non-funding shall not be considered an event of default.
9. **STATUTE OF LIMITATION** - Any clauses limiting the time in which the Agency may bring suit against the Vendor, lessor, individual, or any other party are deleted.
10. **SIMILAR SERVICES** - Any provisions limiting the Agency's right to obtain similar services or equipment in the event of default or non-funding during the term of the agreement are hereby deleted.
11. **ATTORNEY FEES** - The Agency recognizes an obligation to pay attorney's fees or costs only when assessed by a court of competent jurisdiction. Any other provision is invalid and considered null and void.
12. **ASSIGNMENT** - Notwithstanding any clause to the contrary, the Agency reserves the right to assign the agreement to another State of West Virginia agency, board or commission upon thirty (30) days written notice to the Vendor and Vendor shall obtain the written consent of Agency prior to assigning the agreement.
13. **LIMITATION OF LIABILITY** - The Agency, as a State entity, cannot agree to assume the potential liability of a Vendor. Accordingly, any provision limiting the Vendor's liability for direct damages to a certain dollar amount or to the amount of the agreement is hereby deleted. Limitations on special, incidental or consequential damages are acceptable. In addition, any limitation is null and void to the extent that it precludes any action for injury to persons or for damages to personal property.
14. **RIGHT TO TERMINATE** - Agency shall have the right to terminate the agreement upon thirty (30) days written notice to Vendor. Agency agrees to pay Vendor for services rendered or goods received prior to the effective date of termination.
15. **TERMINATION CHARGES** - Any provision requiring the Agency to pay a fixed amount or liquidated damages upon termination of the agreement is hereby deleted. The Agency may only agree to reimburse a Vendor for actual costs incurred or losses sustained during the current fiscal year due to wrongful termination by the Agency prior to the end of any current agreement term.
16. **RENEWAL** - Any reference to automatic renewal is hereby deleted. The agreement may be renewed only upon mutual written agreement of the parties.
17. **INSURANCE** - Any provision requiring the Agency to insure equipment or property of any kind and name the Vendor as beneficiary or as an additional insured is hereby deleted.
18. **RIGHT TO NOTICE** - Any provision for repossession of equipment without notice is hereby deleted. However, the Agency does recognize a right of repossession with notice.
19. **ACCELERATION** - Any reference to acceleration of payments in the event of default or non-funding is hereby deleted.
20. **CONFIDENTIALITY** - Any provision regarding confidentiality of the terms and conditions of the agreement is hereby deleted. State contracts are public records under the West Virginia Freedom of Information Act.
21. **AMENDMENTS** - All amendments, modifications, alterations or changes to the agreement shall be in writing and signed by both parties. No amendment, modification, alteration or change may be made to this addendum without the express written approval of the Purchasing Division and the Attorney General.

ACCEPTED BY:

STATE OF WEST VIRGINIA

Spending Unit: _____

Signed: _____

Title: _____

Date: _____

VENDOR

Company Name: Long's Security Camera Systems LLC

Signed: [Signature]

Title: Owner

Date: 1-6-11

State of West Virginia VENDOR PREFERENCE CERTIFICATE

Certification and application* is hereby made for Preference in accordance with *West Virginia Code*, §5A-3-37. (Does not apply to construction contracts). *West Virginia Code*, §5A-3-37, provides an opportunity for qualifying vendors to request (at the time of bid) preference for their residency status. Such preference is an evaluation method only and will be applied only to the cost bid in accordance with the *West Virginia Code*. This certificate for application is to be used to request such preference. The Purchasing Division will make the determination of the Resident Vendor Preference, if applicable.

- 1. **Application is made for 2.5% resident vendor preference for the reason checked:**
 Bidder is an individual resident vendor and has resided continuously in West Virginia for four (4) years immediately preceding the date of this certification; **or**,
 Bidder is a partnership, association or corporation resident vendor and has maintained its headquarters or principal place of business continuously in West Virginia for four (4) years immediately preceding the date of this certification; or 80% of the ownership interest of Bidder is held by another individual, partnership, association or corporation resident vendor who has maintained its headquarters or principal place of business continuously in West Virginia for four (4) years immediately preceding the date of this certification; **or**,
 Bidder is a nonresident vendor which has an affiliate or subsidiary which employs a minimum of one hundred state residents and which has maintained its headquarters or principal place of business within West Virginia continuously for the four (4) years immediately preceding the date of this certification; **or**,
- 2. **Application is made for 2.5% resident vendor preference for the reason checked:**
 Bidder is a resident vendor who certifies that, during the life of the contract, on average at least 75% of the employees working on the project being bid are residents of West Virginia who have resided in the state continuously for the two years immediately preceding submission of this bid; **or**,
- 3. **Application is made for 2.5% resident vendor preference for the reason checked:**
 Bidder is a nonresident vendor employing a minimum of one hundred state residents or is a nonresident vendor with an affiliate or subsidiary which maintains its headquarters or principal place of business within West Virginia employing a minimum of one hundred state residents who certifies that, during the life of the contract, on average at least 75% of the employees or Bidder's affiliate's or subsidiary's employees are residents of West Virginia who have resided in the state continuously for the two years immediately preceding submission of this bid; **or**,
- 4. **Application is made for 5% resident vendor preference for the reason checked:**
 Bidder meets either the requirement of both subdivisions (1) and (2) or subdivision (1) and (3) as stated above; **or**,
- 5. **Application is made for 3.5% resident vendor preference who is a veteran for the reason checked:**
 Bidder is an individual resident vendor who is a veteran of the United States armed forces, the reserves or the National Guard and has resided in West Virginia continuously for the four years immediately preceding the date on which the bid is submitted; **or**,
- 6. **Application is made for 3.5% resident vendor preference who is a veteran for the reason checked:**
 Bidder is a resident vendor who is a veteran of the United States armed forces, the reserves or the National Guard, if, for purposes of producing or distributing the commodities or completing the project which is the subject of the vendor's bid and continuously over the entire term of the project, on average at least seventy-five percent of the vendor's employees are residents of West Virginia who have resided in the state continuously for the two immediately preceding years.

Bidder understands if the Secretary of Revenue determines that a Bidder receiving preference has failed to continue to meet the requirements for such preference, the Secretary may order the Director of Purchasing to: (a) reject the bid; or (b) assess a penalty against such Bidder in an amount not to exceed 5% of the bid amount and that such penalty will be paid to the contracting agency or deducted from any unpaid balance on the contract or purchase order.

By submission of this certificate, Bidder agrees to disclose any reasonably requested information to the Purchasing Division and authorizes the Department of Revenue to disclose to the Director of Purchasing appropriate information verifying that Bidder has paid the required business taxes, provided that such information does not contain the amounts of taxes paid nor any other information deemed by the Tax Commissioner to be confidential.

Under penalty of law for false swearing (West Virginia Code, §61-5-3), Bidder hereby certifies that this certificate is true and accurate in all respects; and that if a contract is issued to Bidder and if anything contained within this certificate changes during the term of the contract, Bidder will notify the Purchasing Division in writing immediately.

Bidder: Long's Security Camera Systems LLC Signed: [Signature]
 Date: 1-6-11 Title: Owner

*Check any combination of preference consideration(s) indicated above, which you are entitled to receive.



State of West Virginia
DRUG FREE WORKPLACE CONFORMANCE AFFIDAVIT
West Virginia Code §21-1D-5

STATE OF West Virginia
COUNTY OF Kanawha, TO-WIT:

I, Alan E Long, after being first duly sworn, depose and state as follows:

- 1. I am an employee of Long's Security Camera Systems LLC; and,
(Company Name)
- 2. I do hereby attest that Long's Security Camera Systems LLC
(Company Name)

maintains a valid written drug free workplace policy and that such policy is in compliance with **West Virginia Code §21-1D-5**.

The above statements are sworn to under the penalty of perjury.

Long's Security Camera Systems LLC
(Company Name)

By: Alan E Long

Title: Owner

Date: 1-6-11

Taken, subscribed and sworn to before me this 6 day of JAN, 2011

By Commission expires 3/31/2015

(Seal)

[Signature]
(Notary Public)

THIS AFFIDAVIT MUST BE SUBMITTED WITH THE BID IN ORDER TO COMPLY WITH WV CODE PROVISIONS. FAILURE TO INCLUDE THE AFFIDAVIT WITH THE BID SHALL RESULT IN DISQUALIFICATION OF THE BID.

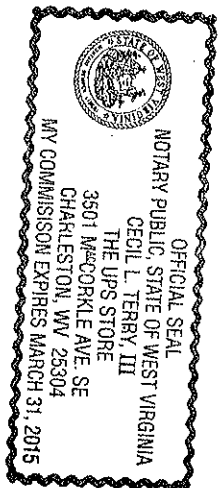

BID CLARIFICATION
For
KeyScan Card Access System w/ Toshiba DVR and Everfocus Cameras

System Scope

The proposed system is a complete IP Card Access System and Hybrid Cameras System. It will be installed on a new security network provide by Longs' Security Camera Systems LLC. All systems have been provided with battery back up.

Card Access: Keri Systems

KeyScan Card Access system is a completely Networkable card access system sized to meet the requirement of the MMB11028, but capable of expanding to cover the car entrance of the facility and other doors. Main software will reside on the system server separate from the client computers. The system server can be installed in any building and will have all the system software installed. The client computers will be installed in the area indicated in the specification. The client computers are separate computer with the client software installed. LSCS will not be using customer's existing computers as clients for this project. Please note that the option to use current computers as client computers is available to the customer for later expansion.

Security Network

A new security network will be installed. Cat5e cable will connect each building. Each building will have a network switch installed. All security equipment will be connected to the new network switches. The Security Network Server will have 3TB of storage installed.

Hybrid Camera System

The Security Camera System is a hybrid based camera system using both IP and analog cameras with "Wide Dynamic Range". These cameras will be connected to the provided digital recorders by analog and IP connections. All camera back-up recording will be stored on the Digital Recorder to which the camera is connected. The Toshiba camera system will integrate with the KeyScan Card Access system through the provided KeyScan CCTV Integration Software. This will provide the customer security camera event recording and card access integration as well as camera surveillance video storage with control. The system is capable of expanding up to 50 cameras or more.

All cameras provided are tamper proof, vandal proof, plus have WDR.

Installation:

Installation is expected to take 60-90 days. This is dependent on the weather and the ease of which work can be performed within the facility.

During the installation all equipment screws will be replaced with security screws, also all installation, where possible will be kept out of the patient areas.

Longs' Security Camera Systems

102 38th Street SE

Charleston West Virginia 25304

Phone: (304) 925-0338 Fax: (304) 925-0338 Email: Longscctv@Suddenlink.net

10 years Experience * BS Electronic Engineering Technology Degree * Military Electronics Trained (USMC Avionics)

Closed Circuit Television System * Complete Digital Recording Solutions * Commercial * Residential

TO: Health and Human Resources	Proposal ID: MMB11028
Attn: MMB11028	Date: 01-06-11
Mildred Mitchell-Bateman Hospital	Terms: At Completion
1530 Norway Avenue	
Huntington, WV 25705	Sales Tax: Not Included
Phone: 304-372-7300	FOB: Job Site
Fax: 304-372-7312	Proposal Expires: N/A

SCOPE OF WORK

Project Name: MMB11028 Equipment Breakout (Does not represent all equipment provided. Detailed information can be provided upon request)

KEYSCAN CARD ACCESS AND TOSHIBA HYBRID CAMERA SYSTEM

Qty	Manufacture	Part Number	Description
5	LSCS	VP1000	100KVA Battery Backup
1	LSCS	Server	Network Server for security software management
4	LSCS	Client	Acer Client Computers
1	KeyScan	System VII	KeyScan System Software w/CCTV Intergration
4	KeyScan	Client	Client Software
7	KeyScan	CA8000	8 Door Controller
1	KeyScan	CA4000	4 Door Controller
1000	KeyScan	HID-C1325	Access Cards
45	KeyScan	KProx-SG	Single Gang Access Card Reader
30	Rutherford	831028	Magnetic Lock 1200lbs
1	Securitron	M62FG	Gate Lock with hardware
2	Toshiba	DVR16241T	16 Channel Digital Recorder 1TB
5	Altronic	ALTV248125	8 Camera Output Power Supply
21	EverFocus	EH650	Outdoor Vandal Proof Wide Dynamic CCTV Camera
5	LSCS	Switch	Network switches
1	LSCS	Lot	Installation materials and Cable
1	LSCS	Lot	Installation Labor

CONTRACTOR LICENSE

Authorized by the

West Virginia Contractor Licensing Board

Number: WV040102

Classification:

LOW VOLTAGE SYSTEMS

LONGS SECURITY CAMERA SYSTEMS LLC
DBA LONGS SECURITY CAMERA SYSTEMS LLC
102 38TH STREET SE
CHARLESTON, WV 25304

Date Issued

MAY 06, 2010

Expiration Date

MAY 06, 2011

Authorized Company Signature

Chair, West Virginia Contractor
Licensing Board

WEST VIRGINIA
CONTRACTOR
LICENSING
BOARD

This license, or a copy thereof, must be posted in a conspicuous place at every construction site where work is being performed. This license number must appear in all advertisements, on all bid submissions and on all fully executed and binding contracts. This license cannot be assigned or transferred by licensee. Issued under provisions of West Virginia Code, Chapter 21, Article 11.

Longs' Security Camera Systems LLC

102 38th Street • Charleston, WV 25304 • Phone: 304-925-0338 • Fax: 304-925-0338
e-mail: longscctv@suddenlink.net

Warranty Statement

The proposed System and Materials are offered according to the following terms and conditions.

“This warranty statement take priority over time covered under this contract. This warranty statement clarifies that Longs' Security Camera Systems will be providing two (2) year warranty on materials and labor”

- TWO-year factory warranty on all equipment and all software unless stated in the proposal.
- TWO-year warranty on all installation labor unless stated in the proposal.
- Warranty coverage includes Technical Labor between the hours of 8:00AM-8:00PM Monday –Sunday.
- Warranty covers only viability of software. Warranty does not cover existing computers, servers, networks, existing network software and/or any conflict of proposed software with existing software. The owner's network administrator will be responsible for establishing available Network IP addresses and Socket Ports.
- Warranty does not cover any wire and/or hardware associated with existing LAN Network.
- Warranty does not cover damage from floods, storms and/or any natural disaster defined as an “Acts of God”.
- Warranty does not cover equipment and /or software that has been tampered with, abused and/or vandalized.
- Longs' Security Camera Systems LLC can not be responsible for delivery delays caused by strikes, accidents or incidents beyond our control.
- Longs' Security Camera Systems LLC can not be responsible for delays due to improper handling and/or any improper deliveries of equipment by delivery companies.
- Warranty voided should the equipment be modified or has any other unauthorized work performed on the system by anyone other than the Longs' Security Camera Systems LLC within the warranty period.



State of West Virginia
 Department of Administration
 Purchasing Division
 2019 Washington Street East
 Post Office Box 50130
 Charleston, WV 25305-0130

Request for Quotation

RFQ NUMBER
 MMB11028

PAGE
 1

ADDRESS CORRESPONDENCE TO ATTENTION OF:
 ROBERTA WAGNER
 304-558-0067

RFQ COPY

TYPE NAME/ADDRESS HERE

*Longs Security Camera Systems LLC
 102 38th ST SE
 Charleston WV 25304*

HEALTH AND HUMAN RESOURCES
 MILDRED MITCHELL-BATEMAN
 HOSPITAL
 1530 NORWAY AVENUE
 HUNTINGTON, WV
 25705 304-525-7801

DATE PRINTED	TERMS OF SALE	SHIP VIA	F.O.B.	FREIGHT TERMS
12/10/2010				

BID OPENING DATE: 01/06/2011 BID OPENING TIME 01:30PM

LINE	QUANTITY	UOP	CAT NO.	ITEM NUMBER	UNIT PRICE	AMOUNT
ADDENDUM NO. 1						
1. QUESTIONS AND ANSWERS ARE ATTACHED. 2. PLEASE NOTE THAT THE BID OPENING HAS BEEN MOVED FROM 12/23/2010 TO 1/6/2011 AT 1:30 PM. 3. ADDENDUM ACKNOWLEDGEMENT IS ATTACHED. THIS DOCUMENT SHOULD BE SIGNED AND RETURNED WITH YOUR BID. FAILURE TO SIGN AND RETURN MAY RESULT IN DISQUALIFICATION OF YOUR BID.						
EXHIBIT 10						
REQUISITION NO.: MMB11028						
ADDENDUM ACKNOWLEDGEMENT						
I HEREBY ACKNOWLEDGE RECEIPT OF THE FOLLOWING CHECKED ADDENDUM(S) AND HAVE MADE THE NECESSARY REVISIONS TO MY PROPOSAL, PLANS AND/OR SPECIFICATION, ETC.						
ADDENDUM NO. S:						
NO. 1 <i>Yes</i>						
NO. 2						
NO. 3						
NO. 4						

SEE REVERSE SIDE FOR TERMS AND CONDITIONS

SIGNATURE <i>Alan E. [Signature]</i>	TELEPHONE 304-925-0338	DATE 1-6-11
TITLE <i>Owner</i>	FEIN 20-3881890-001	ADDRESS CHANGES TO BE NOTED ABOVE

WHEN RESPONDING TO RFQ, INSERT NAME AND ADDRESS IN SPACE ABOVE LABELED 'VENDOR'



State of West Virginia
 Department of Administration
 Purchasing Division
 2019 Washington Street East
 Post Office Box 50130
 Charleston, WV 25305-0130

Request for Quotation

RFQ NUMBER
 MMB11028

PAGE
 2

ADDRESS CORRESPONDENCE TO ATTENTION OF
 ROBERTA WAGNER
 304-558-0067

RFQ COPY

TYPE NAME/ADDRESS HERE

SHIP TO

HEALTH AND HUMAN RESOURCES
 MILDRED MITCHELL-BATEMAN
 HOSPITAL
 1530 NORWAY AVENUE
 HUNTINGTON, WV
 25705 304-525-7801

DATE PRINTED	TERMS OF SALE	SHIP VIA	FOB	FREIGHT TERMS
12/10/2010				

BID OPENING DATE: 01/06/2011 BID OPENING TIME 01:30PM

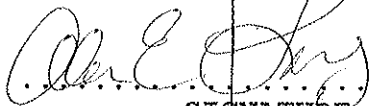
LINE	QUANTITY	UOP	CAT NO	ITEM NUMBER	UNIT PRICE	AMOUNT
NO. 5						
<p>I UNDERSTAND THAT FAILURE TO CONFIRM THE RECEIPT OF THE ADDENDUM(S) MAY BE CAUSE FOR REJECTION OF BIDS.</p> <p>VENDOR MUST CLEARLY UNDERSTAND THAT ANY VERBAL REPRESENTATION MADE OR ASSUMED TO BE MADE DURING ANY ORAL DISCUSSION HELD BETWEEN VENDOR'S REPRESENTATIVES AND ANY STATE PERSONNEL IS NOT BINDING. ONLY THE INFORMATION ISSUED IN WRITING AND ADDED TO THE SPECIFICATIONS BY AN OFFICIAL ADDENDUM IS BINDING.</p> <p style="text-align: center;">  SIGNATURE Lowes Security Concepts Systems LLC COMPANY 1-06-11 DATE </p> <p>NOTE: THIS ADDENDUM ACKNOWLEDGEMENT SHOULD BE SUBMITTED WITH THE BID.</p> <p>REV. 09/21/2009</p> <p style="text-align: center;">END OF ADDENDUM NO. 1</p>						

SEE REVERSE SIDE FOR TERMS AND CONDITIONS

SIGNATURE	TELEPHONE	DATE
TITLE	FEIN	ADDRESS CHANGES TO BE NOTED ABOVE

WHEN RESPONDING TO RFQ, INSERT NAME AND ADDRESS IN SPACE ABOVE LABELED 'VENDOR'

Mildred Mitchell-Bateman Hospital

Q & A Pre-Bid Meeting 12/6/2010

Question 1: Please provide door schedule showing all doors that are READ IN / READ OUT.

Answer 1: Attached is a listing of the doors indicating their READ IN/ READ OUT.

Question 2: Do all junction boxes, etc. have to be installed with tamper proof screws?

Answer 2: Yes. As a psychiatric hospital, our patients must be protected from harming themselves or others by law.

Question No. 3: : 120 day completion time is not attainable. With the submittal process, Fire Marshall review process and equipment delivery, you are looking at a minimum of 80 days just for the submittal and equipment. Please review completion time and provide extension

Answer 3: The project completion time is extended from 120 days to 180 days from the date the Purchase Order is awarded.

Question 4: Please provide scaled drawings so wiring runs can be estimated correctly.

Answer 4. A map of the buildings is attached indicated each building's length and width as well as the location of conduit available between the buildings. Buildings 2-3-4 are connected by a "tunnel" or finished hallway.

Question 5: What type of card do you want for use with the system, one sided or two sided? Do you plan on using the card as an identification card for your staff? What thickness of card is desired?

Answer 5: The hospital desires to use a one-sided card for access and will not be using the same card for identification purposes. The proximity smart contactless card should be 30 ml in thickness and approximately 3.375" x 2.125" in size.

Question 6: : Vendors are requesting a bid extension due the amount of information to be gathered on the project site not shown on drawings or in RFQ to properly bid the project within the time frame allotted.

Answer 6: The bid date for this project originally set at December 23, 2010 is extended to January 6, 2011 at 1:30 p.m. because of the number of holidays closely following it.

Question 7: Will background checks be required for our employee's to work on site? If so, will the State pay for these background checks?

Answer 7: Background checks **WILL NOT** be required.

Question 8: Please clarify bid bond requirements. RFQ states bid bonds are required and the agenda handed out in the pre bid says bid bonds not required.

Answer 8: Bid bond for this project is required in accordance with the original RFQ.

Question 9: Please clarify RFQ bid sheet #1. RFQ item 0003 has line item for 31 proximity card readers. Walk thru indicates there will be more than 31 installed. Please clarify.

Answer 9: See Door Schedule attached indicating which side(s) of the door needs to have a card reader and where the security camera is to be located. All quantities are hereby changed to comply with this schedule and a new bid cost sheet is attached.

Question 10: Please clarify page #6 of the RFQ model/brand/specifications. No manufacture is specified. Are we still to provide literature enclosed with the bid on equipment supplied?

Answer 10: Vendors need to provide literature on the manufacturer of the system they are bidding are planning on using for this project if they are awarded the bid.

Question 11: Please identify the building number and office number for the following location for computers and software; Security Office, Safety Office, Maintenance Department and Switchboard

Answer 11: The Security Office is in Room 143b of Building 3. The Safety Director's Office is on the 2nd floor of Building 5 in Room 202. The System Maintenance location is in Building 1 in Room 04 in the basement. The Switchboard is located in Building 3 in Room 143c on the 1st floor.

Question 12: Does door access control and surveillance system have to integrate in one single system?

Answer 12. Yes, the access controls and surveillance systems must be integrated.

Question 13. 31 cameras are analog, so the network DVR should support to 31 analog input. What's the remaining 19 channel? Please clarify Hybrid DVR(IP + Analog) or Analog DVR.

Answer 13. The remaining 19 channels are for growth if needed. All DVR should be able to record both analog and digital signals, if needed.

Question 14. How many channel of network DVR will be required per DVR? Based on the bid document, I believe 16 channel.

Answer 14. With a need for 31 cameras, we split the need between two DVRs and arrived at 16 channels per DVR, even though only 31 of the 32 available channels will be used initially.

Question 15. Are all indoor domes ceiling mount?

Answer 15. All inside ceiling mounted cameras shall be domed cameras.

Question 16. The RFQ (page 4) states that the access control system shall be designed to include Reader in/Reader out capabilities. However, on page (1) it is asking for a price for 31 readers. I believe that page (1) should have (61) readers. Please clarify.

Answer 16: That answer may be found in the answer and attachments to Question 1 above. There will be a need for electronic door hardware for 31 doors but a need for 45 proximity card readers. See the Schedule of Doors at Question 1.

Question 17. Will all work performed be done on regular day shift hours?

Question 17. All work should be performed at regular rates with regular day shifts while our Maintenance Staff is available if needed.

Question 18. I understand that manufacturers are not listed in the specification. However, it appears as though this specification has been written around a particular manufacturer. Can the manufacturer be disclosed?

Answer 18. As discussed in the pre-bid conference, we put together our needed system and it did not come from a specific manufacturers product. There was no particular manufacturer used.