



State of West Virginia
 Department of Administration
 Purchasing Division
 2019 Washington Street East
 Post Office Box 50130
 Charleston, WV 25305-0130

Request for Quotation

BFO NUMBER
GSD116462

PAGE
1

ADDRESS CORRESPONDENCE TO ATTENTION OF:
KRISTA FERRELL 304-558-2596

RFQ COPY
 TYPE NAME/ADDRESS HERE
One Source Equipment, LP
P.O. Box 909
Throckmorton, TX 76483

DEPARTMENT OF ADMINISTRATION
 GENERAL SERVICES DIVISION
 BUILDING 11 CHILLER PLANT
 218 CALIFORNIA AVENUE
 CHARLESTON, WV
 25305 304-558-2317

DATE PRINTED	TERMS OF SALE	SHIP VIA	F.O.B.	FREIGHT TERMS
05/18/2011				
BID OPENING DATE: 06/09/2011		BID OPENING TIME 01:30PM		

LINE	QUANTITY	UOP	CAT. NO.	ITEM NUMBER	UNIT PRICE	AMOUNT
0001	1	LS		285-37	\$ 6,789.00	\$ 20,367.00
THREE (3) NEW TEREX RL4000 (OR EQUAL) LIGHT TOWERS						
REQUEST FOR QUOTATION (RFQ)						
THE WEST VIRGINIA STATE PURCHASING DIVISION FOR THE AGENCY THE WEST VIRGINIA DIVISION OF GENERAL SERVICES, IS SOLICITING BIDS TO PROVIDE THE AGENCY WITH THREE (3) TEREX MODEL RL4000 LIGHT TOWERS (OR EQUAL) PER THE ATTACHED SPECIFICATIONS.						
TECHNICAL QUESTIONS CONCERNING THIS SOLICITATION MUST BE SUBMITTED IN WRITING TO KRISTA FERRELL IN THE WEST VIRGINIA STATE PURCHASING DIVISION VIA FAX AT 304-558-4115 OR VIA EMAIL AT KRISTA.S.FERRELL@WV.GOV.						
DEADLINE FOR ALL TECHNICAL QUESTIONS IS 05/31/2011 AT THE CLOSE OF BUSINESS.						
ALL TECHNICAL QUESTIONS RECEIVED SHALL BE ANSWERED BY FORMAL WRITTEN ADDENDUM TO BE ISSUED BY THE PURCHASING DIVISION AFTER THE DEADLINE HAS LAPSED.						
ANY VERBAL COMMUNICATION BETWEEN THE VENDOR AND ANY STATE PERSONNEL IS NOT BINDING. ONLY INFORMATION ISSUED IN WRITING AND ADDED TO THE RFQ VIA FORMAL WRITTEN ADDENDUM IS BINDING.						
NO CONTACT BETWEEN THE VENDOR AND THE AGENCY IS PERMITTED WITHOUT THE EXPRESS WRITTEN CONSENT OF THE						

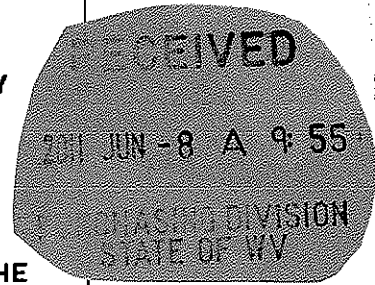

SEE REVERSE SIDE FOR TERMS AND CONDITIONS

SIGNATURE <i>Krista Ferrell</i>	TELEPHONE 940-849-0080	DATE 6/6/11
TITLE VICE PRESIDENT	FEIN 20-0679724	ADDRESS CHANGES TO BE NOTED ABOVE

WHEN RESPONDING TO RFQ, INSERT NAME AND ADDRESS IN SPACE ABOVE LABELED 'VENDOR'



State of West Virginia
 Department of Administration
 Purchasing Division
 2019 Washington Street East
 Post Office Box 50130
 Charleston, WV 25305-0130

Request for Quotation

RFQ NUMBER
GSD116462

PAGE
2

ADDRESS CORRESPONDENCE TO ATTENTION OF
**KRISTA FERRELL
 304-558-2596**

RFQ COPY
 TYPE NAME/ADDRESS HERE

**One Source Equipment, LP
 P.O. Box 909
 Throckmorton, TX 76483**

DEPARTMENT OF ADMINISTRATION
 GENERAL SERVICES DIVISION
 BUILDING 11 CHILLER PLANT
 218 CALIFORNIA AVENUE
 CHARLESTON, WV
 25305 304-558-2317

DATE PRINTED	TERMS OF SALE	SHIP VIA	FOB	FREIGHT TERMS
05/18/2011				

BID OPENING DATE: **06/09/2011** BID OPENING TIME **01:30PM**

LINE	QUANTITY	UOP	CAT NO	ITEM NUMBER	UNIT PRICE	AMOUNT
<p>STATE BUYER. VIOLATION MAY RESULT IN REJECTION OF THE BID. THE STATE BUYER NAMED ABOVE IS THE SOLE CONTACT FOR ANY AND ALL INQUIRIES AFTER THIS RFQ HAS BEEN RELEASED FOR SOLICITATION.</p> <p>BANKRUPTCY: IN THE EVENT THE VENDOR/CONTRACTOR FILES FOR BANKRUPTCY PROTECTION, THE STATE MAY DEEM THE CONTRACT NULL AND VOID, AND TERMINATE SUCH CONTRACT WITHOUT FURTHER ORDER.</p> <p>NOTICE</p> <p>A SIGNED BID MUST BE SUBMITTED TO:</p> <p>DEPARTMENT OF ADMINISTRATION PURCHASING DIVISION BUILDING 15 2019 WASHINGTON STREET, EAST CHARLESTON, WV 25305-0130</p> <p>THE BID SHOULD CONTAIN THIS INFORMATION ON THE FACE OF THE ENVELOPE OR THE BID MAY NOT BE CONSIDERED:</p> <p>SEALED BID</p> <p>BUYER: KRISTA FERRELL-FILE 21</p> <p>RFQ. NO.: GSD116462</p> <p>BID OPENING DATE: 06/09/2011</p> <p>BID OPENING TIME: 1:30 PM</p>						

SEE REVERSE SIDE FOR TERMS AND CONDITIONS

SIGNATURE <i>Krista Ferrell</i>	TELEPHONE 940-849-0080	DATE 6/6/11
TITLE VICE PRESIDENT	FERN 20-0679724	ADDRESS CHANGES TO BE NOTED ABOVE

WHEN RESPONDING TO RFQ, INSERT NAME AND ADDRESS IN SPACE ABOVE LABELED 'VENDOR'

GENERAL TERMS & CONDITIONS REQUEST FOR QUOTATION (RFQ) AND REQUEST FOR PROPOSAL (RFP)

1. Awards will be made in the best interest of the State of West Virginia.
2. The State may accept or reject in part, or in whole, any bid.
3. Prior to any award, the apparent successful vendor must be properly registered with the Purchasing Division and have paid the required \$125 fee.
4. All services performed or goods delivered under State Purchase Order/Contracts are to be continued for the term of the Purchase Order/Contracts, contingent upon funds being appropriated by the Legislature or otherwise being made available. In the event funds are not appropriated or otherwise available for these services or goods this Purchase Order/Contract becomes void and of no effect after June 30.
5. Payment may only be made after the delivery and acceptance of goods or services.
6. Interest may be paid for late payment in accordance with the *West Virginia Code*.
7. Vendor preference will be granted upon written request in accordance with the *West Virginia Code*.
8. The State of West Virginia is exempt from federal and state taxes and will not pay or reimburse such taxes.
9. The Director of Purchasing may cancel any Purchase Order/Contract upon 30 days written notice to the seller.
10. The laws of the State of West Virginia and the *Legislative Rules* of the Purchasing Division shall govern the purchasing process.
11. Any reference to automatic renewal is hereby deleted. The Contract may be renewed only upon mutual written agreement of the parties.
12. **BANKRUPTCY:** In the event the vendor/contractor files for bankruptcy protection, the State may deem this contract null and void, and terminate such contract without further order.
13. **HIPAA BUSINESS ASSOCIATE ADDENDUM:** The West Virginia State Government HIPAA Business Associate Addendum (BAA), approved by the Attorney General, is available online at www.state.wv.us/admin/purchase/vrc/hipaa.htm and is hereby made part of the agreement. Provided that the Agency meets the definition of a Cover Entity (45 CFR §160.103) and will be disclosing Protected Health Information (45 CFR §160.103) to the vendor.
14. **CONFIDENTIALITY:** The vendor agrees that he or she will not disclose to anyone, directly or indirectly, any such personally identifiable information or other confidential information gained from the agency, unless the individual who is the subject of the information consents to the disclosure in writing or the disclosure is made pursuant to the agency's policies, procedures, and rules. Vendor further agrees to comply with the Confidentiality Policies and Information Security Accountability Requirements, set forth in <http://www.state.wv.us/admin/purchase/privacy/noticeConfidentiality.pdf>.
15. **LICENSING:** Vendors must be licensed and in good standing in accordance with any and all state and local laws and requirements by any state or local agency of West Virginia, including, but not limited to, the West Virginia Secretary of State's Office, the West Virginia Tax Department, and the West Virginia Insurance Commission. The vendor must provide all necessary releases to obtain information to enable the director or spending unit to verify that the vendor is licensed and in good standing with the above entities.
16. **ANTITRUST:** In submitting a bid to any agency for the State of West Virginia, the bidder offers and agrees that if the bid is accepted the bidder will convey, sell, assign or transfer to the State of West Virginia all rights, title and interest in and to all causes of action it may now or hereafter acquire under the antitrust laws of the United States and the State of West Virginia for price fixing and/or unreasonable restraints of trade relating to the particular commodities or services purchased or acquired by the State of West Virginia. Such assignment shall be made and become effective at the time the purchasing agency tenders the initial payment to the bidder.

I certify that this bid is made without prior understanding, agreement, or connection with any corporation, firm, limited liability company, partnership, or person or entity submitting a bid for the same material, supplies, equipment or services and is in all respects fair and without collusion or fraud. I further certify that I am authorized to sign the certification on behalf of the bidder or this bid.

INSTRUCTIONS TO BIDDERS

1. Use the quotation forms provided by the Purchasing Division. Complete all sections of the quotation form.
2. Items offered must be in compliance with the specifications. Any deviation from the specifications must be clearly indicated by the bidder. Alternates offered by the bidder as **EQUAL** to the specifications must be clearly defined. A bidder offering an alternate should attach complete specifications and literature to the bid. The Purchasing Division may waive minor deviations to specifications.
3. Unit prices shall prevail in case of discrepancy. All quotations are considered F.O.B. destination unless alternate shipping terms are clearly identified in the quotation.
4. All quotations must be delivered by the bidder to the office listed below prior to the date and time of the bid opening. Failure of the bidder to deliver the quotations on time will result in bid disqualifications: Department of Administration, Purchasing Division, 2019 Washington Street East, P.O. Box 50130, Charleston, WV 25305-0130
5. Communication during the solicitation, bid, evaluation or award periods, except through the Purchasing Division, is strictly prohibited (W.Va. C.S.R. §148-1-6.6).

State of West Virginia
General Services Division

West Virginia State Capitol
GSD116462 Light Towers Purchase

REQUEST FOR QUOTATIONS #GSD116462
PURCHASE OF THREE (3) LIGHT TOWERS

Location: West Virginia Department of Administration
General Services Division
1900 Kanawha Boulevard East
Building One, Room MB60
Charleston, West Virginia 25305

For: State of West Virginia
General Services Division
1900 Kanawha Boulevard, East
Building One, Room MB60
Charleston, West Virginia 25305

All inquiries for specification clarification shall be addressed to:
Krista Ferrell, Buyer Supervisor
Purchasing Division
P.O. Box 50130
Charleston, West Virginia 25305-0130
Fax: (304) 558-4115
krista.s.ferrell@wv.gov

The Acquisition and Contract Administration Section of the Purchasing Division "State" for the West Virginia General Services Division is soliciting quotations for the purchase of three (3) new portable light towers.

Any services contracted for prior to receipt of the signed purchase order and notice-to-proceed letter shall be at the Bidder's risk.

General Conditions

- A. Vendor must supply 12-month (or greater) manufacturer's warranty for product.
- B. Freight will be FOB-Destination; all charges for delivery of equipment to the Agency's location at the State Capitol Complex in Charleston, WV, must be incorporated into the bid.
- C. Units shall be shipped or delivered to the lot behind the Central Chiller Plant, located at 218 California Avenue on the WV State Capitol Complex. Arrangements shall be made by the successful bidder prior to delivery with David Parsons, Operations & Maintenance Manager (304-957-7122), to insure the lot is accessible.

State of West Virginia
General Services Division

West Virginia State Capitol
GSD116462 Light Towers Purchase

Technical Specifications

The Agency wishes to purchase three (3) Terex Model#RL4000 Light Towers, or equal.

Brand and model specification is given to establish the acceptable level of performance and quality only, and not to limit competition. Bidders submitting alternate models or brands should include documentation to support that the offered equipment meets the following specifications:

1. Tower should raise to at least 30'(from ground to top of tower when fully extended)
2. Minimum four (4) lights on each tower of minimum 1000W each
3. Tower shall have 360 degree rotation capability without moving the base.
4. Unit shall be diesel powered.
5. Unit shall have standard hitch and towing package and be road-ready
6. Light tower shall have auxiliary generator capacity for at least one (1) 20-amp, 120V circuit.
7. Minimum 48 hours run-time per tank of fuel
8. Unit must come with the ability to be lifted by fork truck (ie, fork lift pockets).
9. Lights shall be High-Intensity Discharge (HID), Metal Halide (MH)
10. Unit should operate at no louder than 75 dBA at a distance of approximately 25 feet

Invoices

One single invoice for all three towers shall be submitted to the Agency for payment (in arrears) and must include the following information:

1. Copies of all packing slips signed and dated by the Agency Representative
2. FEIN number and complete address of vendor
3. This purchase order number (GSD116462)

Invoices shall be mailed to the following address:

Department of Administration
General Services Division
State Capitol Complex
Building 1, Room MB-68
1900 Kanawha Blvd. E.
Charleston, West Virginia 25305

Should the Vendor be requested by the Agency or volunteer to submit invoices electronically, invoices must meet the digital requirements of the WV State Auditor's Office.

State of West Virginia
General Services Division

West Virginia State Capitol
GSD116462 Light Towers Purchase

Bid Form

Provide three (3) Terex RL4000 (or equal) light towers:

Price Each: \$ 6789.⁰⁰

X 3 (Quantity 3 requested)

Total Bid: \$ 20,367.⁰⁰

Vendor signature and date Kevin Keeter

Vendor Address P.O. Box 909

Throckmorton TX 76483

Vendor Contact Name KEVIN KEETER

Vendor Phone Number 940 - 849 - 0080

Vendor Fax Number 940 - 849 - 0082

Vendor Email Address SALES@ONESOURCEEQUIPMENT.COM

Genie Limited Warranty

A TEREX COMPANY

Genie Industries, Inc. warrants this product to be free from defects in material and workmanship from the date the product is originally invoiced to the purchaser or from the date the new product is first put into service, whichever comes first. Warranty coverage periods are as follows:

Structural elements

Aerial lifts 5 years
Towed products 1 year
All other models and service parts 1 year

Self-propelled booms, scissor lifts and telehandlers only

Hydraulic componentry (except below) 3 years
O-rings, seals, hoses and brakes 1 year

GENIE GIVES NO WARRANTY WHATSOEVER FOR THE PARTS, EQUIPMENT OR EXCHANGE COMPONENTS DESCRIBED BELOW, EXCEPT AS TO TITLE, BUT ASSIGNS WHATEVER WARRANTY IT RECEIVES FROM THE MANUFACTURER AND/OR SUPPLIER WHO IS THE SOLE SOURCE OF ANY WARRANTY RECOVERY.

Components include:

Engines	Transmissions	Generator / Gensets
Tires	Batteries	Axles

Items specifically not covered under warranty include:

Lamps	Lenses	Filters
Utility trailer deck Shop supplies		

GENIE will repair or replace, at its option, the defective material or workmanship at its factory or authorized service center. Buyer shall be responsible for all freight charges incurred in sending the product to an authorized service center or to Genie for repair and in returning it to Buyer. Repairs, damage or defects resulting from the following are specifically excluded from coverage under this warranty: chemical, abrasive or accidental damage; misuse or abuse; inadequate or improper maintenance; unauthorized alterations or repairs; and normal wear and tear.

THE FOREGOING REMEDY IS EXCLUSIVE, AND BY ACCEPTING DELIVERY OF THIS PRODUCT, BUYER AGREES THAT GENIE SHALL HAVE NO OTHER WARRANTY, OBLIGATION, OR LIABILITY TO BUYER WITH RESPECT TO ANY NONCONFORMANCE OR DEFECT IN THE PRODUCT, INSTRUCTIONS, OR ANY OTHER THING DELIVERED HEREUNDER; THAT GENIE SPECIFICALLY EXCLUDES ANY IMPLIED WARRANTY OF MERCHANTABILITY OR FITNESS FOR A PARTICULAR PURPOSE, OR IMPLIED WARRANTY ARISING FROM COURSE OF PERFORMANCE, COURSE OF DEALING, USAGE OR TRADE; AND THAT GENIE HAS NO OBLIGATION OR LIABILITY, AND THAT THE BUYER HAS NO RIGHT, CLAIM OR REMEDY IN TORT, WHETHER OR NOT ARISING FROM THE NEGLIGENCE OF GENIE (WHETHER ACTIVE, PASSIVE OR IMPUTED) OR FOR LOSS OF OR DAMAGE TO ANY GENIE PRODUCT.

UNDER NO CIRCUMSTANCE SHALL GENIE HAVE ANY OBLIGATION OR LIABILITY, WHETHER ARISING IN CONTRACT, TORT OR OTHERWISE, FOR LOSS OF USE, REVENUE, OR PROFIT WITH RESPECT TO ANY NONCONFORMANCE OR DEFECT IN ANY GENIE PRODUCT, INSTRUCTION, OR OTHER THING DELIVERED HEREUNDER OR FOR ANY DIRECT, INCIDENTAL, OR CONSEQUENTIAL DAMAGES. THE MAXIMUM LIABILITY OF GENIE UNDER THIS WARRANTY SHALL BE THE AMOUNT PAID TO GENIE FOR THE PRODUCT.

Qualification for warranty coverage hereunder is absolutely conditioned upon:

- (1) Genie's receipt of completed product warranty registration within ten (10) days from sale or from placement into service, whichever comes first;
- (2) Notice to Genie of any claimed defect, or personal injury or property damage arising from a possible defect, within forty eight (48) hours of discovery or occurrence; and
- (3) Immediate access being provided to Genie for the inspection of the product before alteration, of the premises and of all applicable records.

This warranty supersedes all other warranties, stated or published.

All warranty claims are subject to approval by Genie's warranty department. Genie Industries reserves the right to limit or adjust claims with regard to defective parts, labor or travel miles and time based on Genie warranty guidelines.

Genie Industries USA
18340 NE 76th Street
PO Box 97030
Redmond, WA 98073-9730
(425) 881-1800

Genie UK
The Maltings, Wharf Road
Grantham, Lincolnshire
NG31-6BH England
(44) 1476-584383

Copyright © 1998 by Genie Industries.
Genie® is a registered
trademark of Genie Industries.
Printed in U.S.A. 10-05-06
Part No. 82355

Genie
A TEREX COMPANY

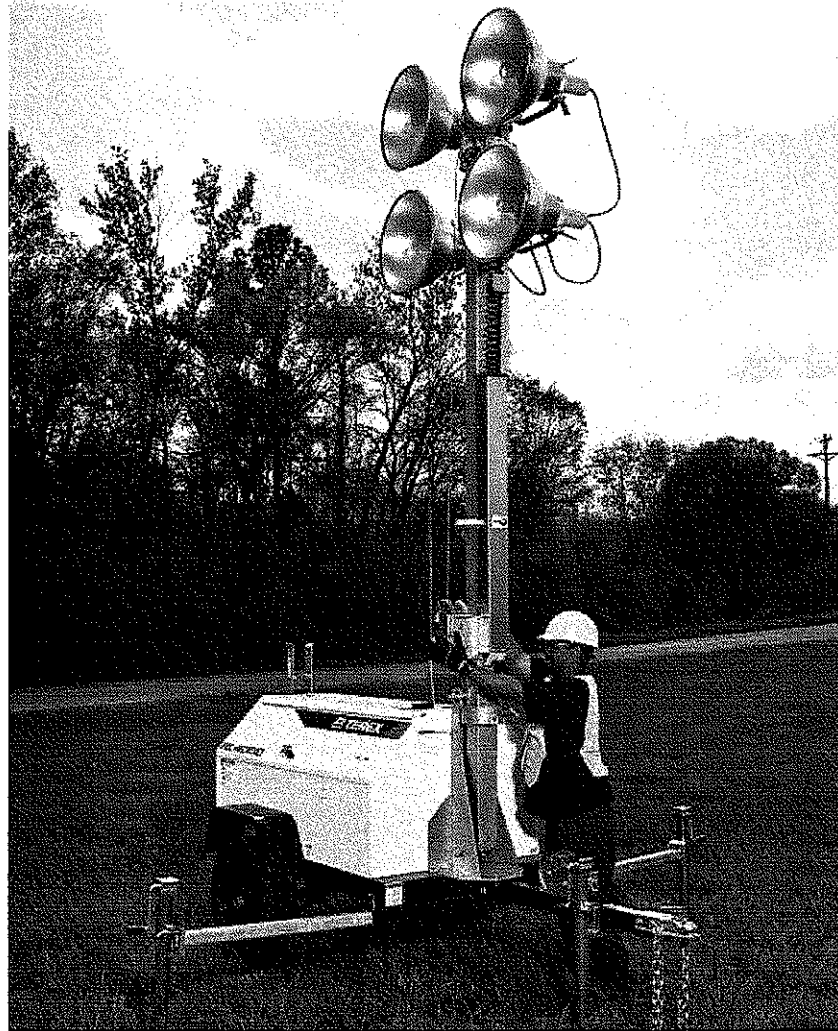
Light Towers

LIGHT TOWER
RL4000

Features

- Dual self-braking winch design for fast and easy tower erection and extension.
- 30 ft (9.14 m) light height at full extension for excellent illumination at long distances.
- 359 degree non-continuous tower rotation to provide pin-point light positioning at your work site.
- 4,000 Watts of light
- Quiet 71 dBA sound levels at 23 feet (7 m).
- Excellent fuel economy providing up to 60 hours of run time per tank of fuel.
- Maintenance-friendly electrical assemblies make troubleshooting, service and repair a breeze.
- 3 cylinder diesel engine powers a brushless self regulated type generator.
- Centerpoint lifting bracket and fork lift pockets make transport easy.
- Compact design allows up to 10 units per truck load.
- Engine protection includes high water temperature and low oil pressure shutdowns.
- Cabinet is protected with a durable, fade resistant finish.

Light Towers RL4000

Specifications

Lamps	Metal halide 4 x 1,000 W
Generator	Brushless 60 Hz, 6.0 kW
Engine	Kubota diesel 13.6 hp
Receptacles	One GFI duplex 20 A / 120 V One T/L 30 A / 240 V
Fuel capacity	30 gal (114 L)
Wheel size	13" (33 cm)
Axle rating	2,000 lbs (907 kg)
Tongue weight travel position	199 lbs (91 kg)
Total weight no fuel	1,725 lbs (783 kg)

Notice: Metal halide lamp bulbs contain mercury (Hg).
Dispose of lamp bulbs according to local, state and federal laws.

Options and Accessories

- 12 volt dome light with switch
- 4 horizontally mounted lights, cast aluminum square housing
- 50 hz, 7 kW generator, 13.6 hp Kubota engine
- 60 hz, 8 kW generator, 13.6 hp Kubota engine
- 60 hz, 6 kW generator, Perkins Tier IV 13.8 hp
- 700 CCA battery
- Battery heater blanket
- Block heater
- Combination ring/ball hitch
- DOT tail light package (6 or 7 pole)
- Export racking/preparation
- Fuel/water separator filter
- Fuel/water separator with fuel line heater
- Low temperature coolant mixture (-40 deg F)
- Ring hitch 2.5"

Dimensions

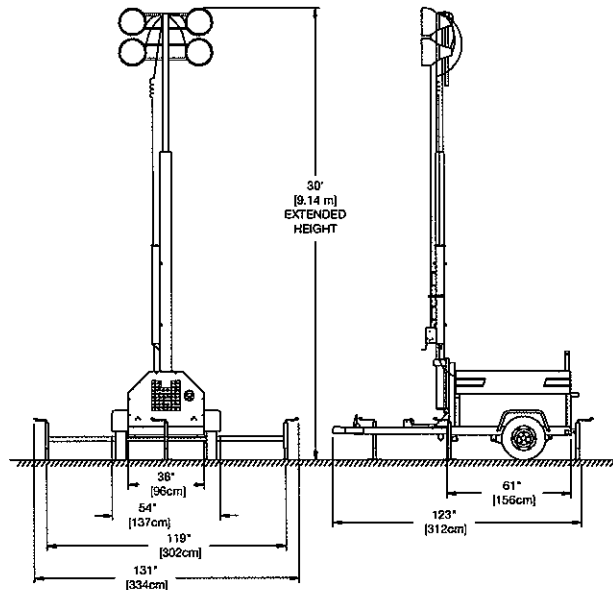
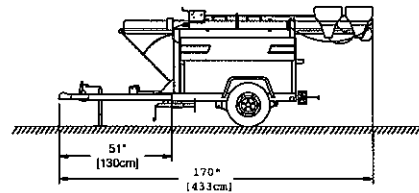
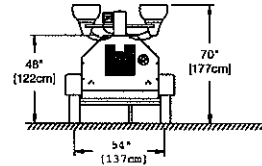

Terex Aerial Work Platforms

18340 NE 76th Street
PO Box 97030
Redmond, WA 98073-9730

TEL +1 (425) 881-1800
TOLL FREE +1 (800) 536-1800
PARTS & TECH SUPPORT +1 (800) 228-6444
FAX +1 (425) 883-3475
WEB www.genieindustries.com

For more information, product demonstration, or details on purchase, lease and rental plans, please contact your local Terex AWP distributor.

Effective Date: April, 2011. Product specifications and prices are subject to change without notice or obligation. The photographs and/or drawings in this document are for illustrative purposes only. Refer to the appropriate Operator's Manual for instructions on the proper use of this equipment. Failure to follow the appropriate Operator's Manual when using our equipment or to otherwise act irresponsibly may result in serious injury or death. The only warranty applicable to our equipment is the standard written warranty applicable to the particular product and sale and we make no other warranty, express or implied. Products and services listed may be trademarks, service marks or trade-names of Terex Corporation, Genie Industries, Inc. and/or their subsidiaries in the U.S.A. and many other countries. All rights are reserved. Terex® is a registered trademark of Terex Corporation in the U.S.A. and many other countries. Genie® is a registered trademark of Genie Industries, Inc. in the U.S.A. and many other countries. Genie is a Terex Brand. © 2011 Terex Corporation. RL4000 0210F Part #109044

State of West Virginia

GSD116462

VENDOR PREFERENCE CERTIFICATE

Certification and application* is hereby made for Preference in accordance with West Virginia Code, §5A-3-37. (Does not apply to construction contracts). West Virginia Code, §5A-3-37, provides an opportunity for qualifying vendors to request (at the time of bid) preference for their residency status. Such preference is an evaluation method only and will be applied only to the cost bid in accordance with the West Virginia Code. This certificate for application is to be used to request such preference. The Purchasing Division will make the determination of the Resident Vendor Preference, if applicable.

- 1. Application is made for 2.5% resident vendor preference for the reason checked: Bidder is an individual resident vendor and has resided continuously in West Virginia for four (4) years immediately preceding the date of this certification; or, Bidder is a partnership, association or corporation resident vendor and has maintained its headquarters or principal place of business continuously in West Virginia for four (4) years immediately preceding the date of this certification; or 80% of the ownership interest of Bidder is held by another individual, partnership, association or corporation resident vendor who has maintained its headquarters or principal place of business continuously in West Virginia for four (4) years immediately preceding the date of this certification; or, Bidder is a nonresident vendor which has an affiliate or subsidiary which employs a minimum of one hundred state residents and which has maintained its headquarters or principal place of business within West Virginia continuously for the four (4) years immediately preceding the date of this certification; or,
2. Application is made for 2.5% resident vendor preference for the reason checked: Bidder is a resident vendor who certifies that, during the life of the contract, on average at least 75% of the employees working on the project being bid are residents of West Virginia who have resided in the state continuously for the two years immediately preceding submission of this bid; or,
3. Application is made for 2.5% resident vendor preference for the reason checked: Bidder is a nonresident vendor employing a minimum of one hundred state residents or is a nonresident vendor with an affiliate or subsidiary which maintains its headquarters or principal place of business within West Virginia employing a minimum of one hundred state residents who certifies that, during the life of the contract, on average at least 75% of the employees or Bidder's affiliate's or subsidiary's employees are residents of West Virginia who have resided in the state continuously for the two years immediately preceding submission of this bid; or,
4. Application is made for 5% resident vendor preference for the reason checked: Bidder meets either the requirement of both subdivisions (1) and (2) or subdivision (1) and (3) as stated above; or,
5. Application is made for 3.5% resident vendor preference who is a veteran for the reason checked: Bidder is an individual resident vendor who is a veteran of the United States armed forces, the reserves or the National Guard and has resided in West Virginia continuously for the four years immediately preceding the date on which the bid is submitted; or,
6. Application is made for 3.5% resident vendor preference who is a veteran for the reason checked: Bidder is a resident vendor who is a veteran of the United States armed forces, the reserves or the National Guard, if, for purposes of producing or distributing the commodities or completing the project which is the subject of the vendor's bid and continuously over the entire term of the project, on average at least seventy-five percent of the vendor's employees are residents of West Virginia who have resided in the state continuously for the two immediately preceding years.

Bidder understands if the Secretary of Revenue determines that a Bidder receiving preference has failed to continue to meet the requirements for such preference, the Secretary may order the Director of Purchasing to: (a) reject the bid; or (b) assess a penalty against such Bidder in an amount not to exceed 5% of the bid amount and that such penalty will be paid to the contracting agency or deducted from any unpaid balance on the contract or purchase order.

By submission of this certificate, Bidder agrees to disclose any reasonably requested information to the Purchasing Division and authorizes the Department of Revenue to disclose to the Director of Purchasing appropriate information verifying that Bidder has paid the required business taxes, provided that such information does not contain the amounts of taxes paid nor any other information deemed by the Tax Commissioner to be confidential.

Under penalty of law for false swearing (West Virginia Code, §61-5-3), Bidder hereby certifies that this certificate is true and accurate in all respects; and that if a contract is issued to Bidder and if anything contained within this certificate changes during the term of the contract, Bidder will notify the Purchasing Division in writing immediately.

Bidder: _____ Signed: _____

Date: _____ Title: _____

*Check any combination of preference consideration(s) indicated above, which you are entitled to receive.

OUT OF STATE - N/A - KEVIN KEETER / [Signature]

GSD116462

RFQ No. _____

STATE OF WEST VIRGINIA
Purchasing Division

PURCHASING AFFIDAVIT

West Virginia Code §5A-3-10a states: No contract or renewal of any contract may be awarded by the state or any of its political subdivisions to any vendor or prospective vendor when the vendor or prospective vendor or a related party to the vendor or prospective vendor is a debtor and the debt owed is an amount greater than one thousand dollars in the aggregate.

DEFINITIONS:

"Debt" means any assessment, premium, penalty, fine, tax or other amount of money owed to the state or any of its political subdivisions because of a judgment, fine, permit violation, license assessment, defaulted workers' compensation premium, penalty or other assessment presently delinquent or due and required to be paid to the state or any of its political subdivisions, including any interest or additional penalties accrued thereon.

"Debtor" means any individual, corporation, partnership, association, limited liability company or any other form or business association owing a debt to the state or any of its political subdivisions. "Political subdivision" means any county commission; municipality; county board of education; any instrumentality established by a county or municipality; any separate corporation or instrumentality established by one or more counties or municipalities, as permitted by law; or any public body charged by law with the performance of a government function or whose jurisdiction is coextensive with one or more counties or municipalities. "Related party" means a party, whether an individual, corporation, partnership, association, limited liability company or any other form or business association or other entity whatsoever, related to any vendor by blood, marriage, ownership or contract through which the party has a relationship of ownership or other interest with the vendor so that the party will actually or by effect receive or control a portion of the benefit, profit or other consideration from performance of a vendor contract with the party receiving an amount that meets or exceed five percent of the total contract amount.

EXCEPTION: The prohibition of this section does not apply where a vendor has contested any tax administered pursuant to chapter eleven of this code, workers' compensation premium, permit fee or environmental fee or assessment and the matter has not become final or where the vendor has entered into a payment plan or agreement and the vendor is not in default of any of the provisions of such plan or agreement.

Under penalty of law for false swearing (*West Virginia Code §61-5-3*), it is hereby certified that the vendor affirms and acknowledges the information in this affidavit and is in compliance with the requirements as stated.

WITNESS THE FOLLOWING SIGNATURE

Vendor's Name: ONE SOURCE EQUIPMENT, LP

Authorized Signature: *Cynthia Ford* Date: 6/7/11

State of Texas

County of Dallas, to-wit:

Taken, subscribed, and sworn to before me this 7th day of June, 2011.

My Commission expires December 6th, 2011.

AFFIX SEAL HERE

NOTARY PUBLIC

[Handwritten Signature]

