



State of West Virginia
 Department of Administration
 Purchasing Division
 2019 Washington Street East
 Post Office Box 50130
 Charleston, WV 25305-0130

Request for Quotation

RFQ NUMBER
DNR211088

PAGE
1

ADDRESS CORRESPONDENCE TO ATTENTION OF
**FRANK WHITTAKER
 304-558-2316**

***A25112652 800-752-7178
 POLAR KING INTERNATIONAL INC
 4424 NEW HAVEN AVENUE
 FORT WAYNE IN 46803**

**DIVISION OF NATURAL RESOURCES
 219/250 WARD ROAD
 ELKINS, WV
 26241 304-637-0245**

DATE PRINTED	TERMS OF SALE	SHIP VIA	F.O.B.	FREIGHT TERMS
01/12/2011				

BID OPENING DATE: **02/15/2011** BID OPENING TIME **01:30PM**

LINE	QUANTITY	UOP	CAT. NO.	ITEM NUMBER	UNIT PRICE	AMOUNT
0001	1	EA		740-13		52,294.16
<p>WALK-IN COOLER/FREEZER</p> <p>THE WEST VIRGINIA PURCHASING DIVISION, FOR THE AGENCY, THE WEST VIRGINIA DIVISION OF NATURAL RESOURCES, IS SOLICITING BIDS FOR A SINGLE-UNIT WALK-IN COOLER AND FREEZER PER THE ATTACHED SPECIFICATIONS.</p> <p>ALL TECHNICAL QUESTIONS MUST BE SUBMITTED IN WRITING TO FRANK WHITTAKER IN THE WV PURCHASING DIVISION VIA EMAIL AT FRANK.M.WHITTAKER@WV.GOV OR VIA FAX AT 304-558-4115. DEADLINE FOR TECHNICAL QUESTIONS IS 01/25/2011 AT 4:00 PM. ALL TECHNICAL QUESTIONS WILL BE ADDRESSED BY ADDENDUM AFTER THE DEADLINE.</p> <p>BANKRUPTCY: IN THE EVENT THE VENDOR/CONTRACTOR FILES FOR BANKRUPTCY PROTECTION, THE STATE MAY DEEM THE CONTRACT NULL AND VOID, AND TERMINATE SUCH CONTRACT WITHOUT FURTHER ORDER.</p> <p>NOTICE</p> <p>A SIGNED BID MUST BE SUBMITTED TO:</p> <p>DEPARTMENT OF ADMINISTRATION PURCHASING DIVISION BUILDING 15 2019 WASHINGTON STREET, EAST CHARLESTON, WV 25305-0130</p>						

RECEIVED
 2011 FEB -9 AM 11:56
 WV PURCHASING DIVISION

SEE REVERSE SIDE FOR TERMS AND CONDITIONS

SIGNATURE: *B. Markham* TELEPHONE: 260-428-2551 DATE: 2-7-2011
 TITLE: Regional Sales Mgr FEIN: 35-175-8969
 ADDRESS CHANGES TO BE NOTED ABOVE

WHEN RESPONDING TO RFQ, INSERT NAME AND ADDRESS IN SPACE ABOVE LABELED 'VENDOR'

The West Virginia Purchasing Division for the West Virginia Division of Natural Resources is requesting bids for the purchase of one (1) Single-Unit Walk-in Cooler and Freezer. All items are to be F.O.B. Destination. Freight or delivery charges must be included in the price of the goods. Delivery must be made between April 18 and May 15, 2011.

General Specifications:

The Single-Unit Walk-in Cooler and Freezer must be manufactured for commercial use. All items must be new (2011 model).

Damaged Items:

Damaged or defective items must be replaced at no additional expense to The West Virginia Division of Natural Resources.

Warranty:

The warranty must be for a minimum of ten (10) years on the structure, one (1) year on the compressors and one (1) year on all other parts and systems. However, if manufacturer warranty periods are longer than the required minimum, those warranties shall apply.

Single-Unit Walk-in Cooler and Freezer

Single-Unit Walk-in Cooler and Freezer must meet the following specifications:

- Must be completely assembled, off-loaded and set in place on an outdoor pad for through-wall installation against the side of purchaser's existing building.
- Must have exterior dimensions not to exceed 30' long x 10' wide x 8' 4" high on the high side of a sloped roof (see attached diagram).
- Must have interior dimensions of approximately 11' x 9' for the cooler section and approximately 17' x 9' for the freezer section, with the interior (ceiling) height not exceeding 7' or being less than 6' 6".
- Must be constructed with: a welded, heavy-duty steel frame (minimum 1 ½" X 3" 11 gauge steel tube); with a minimum 5" urethane board insulation (minimum R-factor of 32); and 100% seamless fiberglass interior and exterior walls, floor, ceiling, doors and roof bonded to the urethane insulation. Doors must have a standard 36" entrance door and be equipped with door frame heaters sufficient to prevent condensation or frost accumulation on thru-wall doors.

- Must have floor reinforced with woven fiberglass matting over a plywood subfloor (minimum thickness of ½") bonded to the urethane core and have a skid-resistant surface coating, which can support at least 900 lb./s.f. of evenly-distributed load or a floor system of equal strength and durability.
- Must have all doors equipped with: magnetic gaskets around the perimeter; adjustable, vinyl sweep gaskets; positive snap action latches with adjustable strike, cylinder locks, and OSHA-approved interior safety release mechanisms; and multiple heavy duty strap type hinges of a cam lift, self closing, nylon bushing type with lift off capability, dial type thermometers on the thru-wall doors and locations and opening directions as indicated on the attached drawing(s)
- Must have outdoor cooler entrance door with a locking mechanism, rain cap and vinyl strip curtain.
- Must have lights (one in cooler and two in freezer) that use compact fluorescent bulbs installed with switches (3-way in cooler) at each door and shall be contained in vapor-proof fixtures.
- Must have a floor drain installed in the cooler section with a minimum of ¾" (larger if possible) x 2" male pvc extension beyond the unit wall at the location indicated on the attached diagram(s).
- Must have refrigeration systems which must be mounted on the out-slope side of the unit roof; completely assembled, installed and ready to operate with single-point electrical connection on site by the purchaser; utilize R-404a non-flammable refrigerant or equal; operate on a minimum 208 to maximum 230 volt, 60 hz, single-phase electrical power; be a minimum of 1.25 hp for the cooler and 1.5 hp for the freezer; air-cooled condensers; Copeland hermetic/semi-hermetic compressors (or equal) with overload protection; receiver tank with liquid shut off valve; liquid line filter/dryer and sight glass; high/low pressure control; liquid line solenoid valve; crankcase heater; minimum of -20 degrees F to maximum of -40 degrees F low ambient controls; room thermostats; UL labeled electrical control panel(s); electric defrost with condensate piped to the exterior of the unit; fan guards; and weather hoods matching the exterior of the unit.
- Must have refrigeration systems sufficient to achieve and maintain unit temperatures of 35° F in the cooler and 0° F in the freezer based on infrequent loadings of product at ambient temperature.
- Must have sectional, wire mesh, and 3-tier (cooler section) and 4-tier (cooler and freezer sections) adjustable shelving units of approximately 18" width installed in each unit as shown in the attached drawing(s).
- Must have freezer section equipped with three lockable security units, with a minimum of three and a maximum of four (approximately 18" x 48") adjustable/removable shelves, not to exceed 67" total height located as indicated on the attached drawing(s).

- Must have a 30' roof flashing kit, side wall flashing kit and 50' of exterior base skirting to be installed by the purchaser to completely seal the unit to the purchaser's building.

One (1) Single-Unit Walk-in Cooler and Freezer Delivered to:

West Virginia Division of Natural Resources

219/250 Ward Road

Elkins, WV 26241

Contact Gary Foster (304)637-0245 for delivery information.

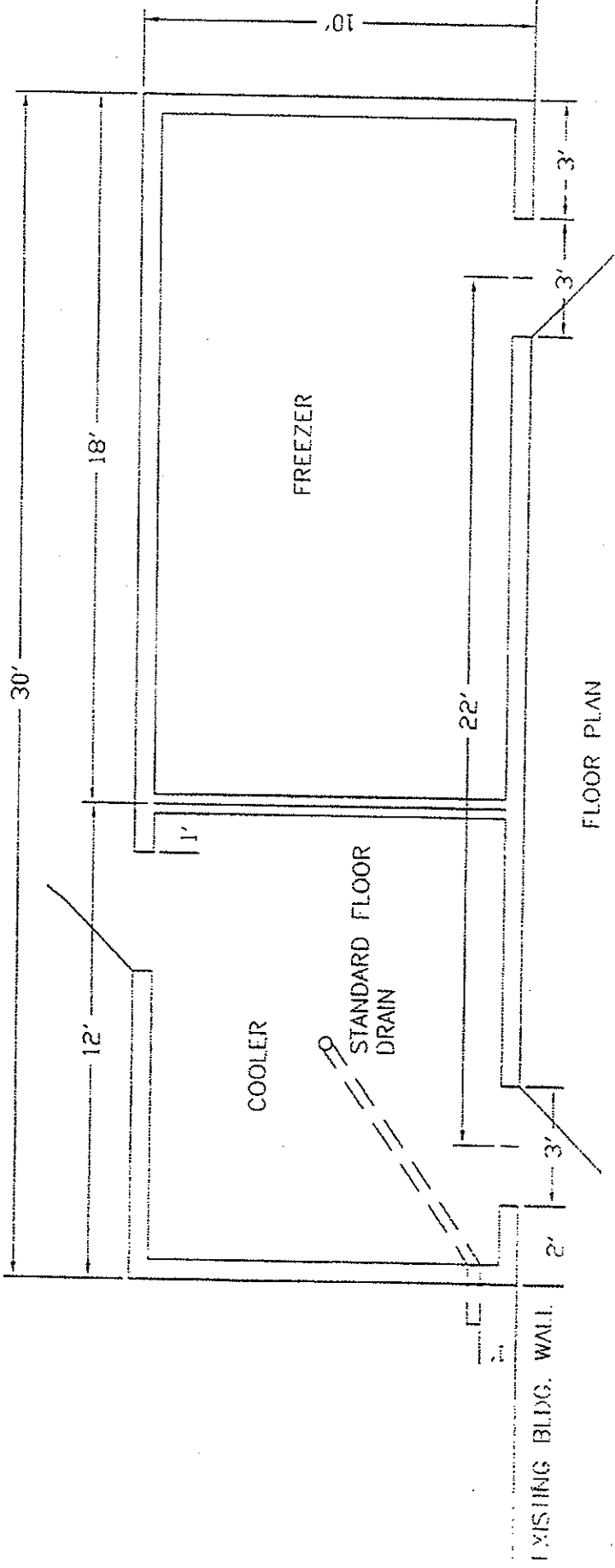
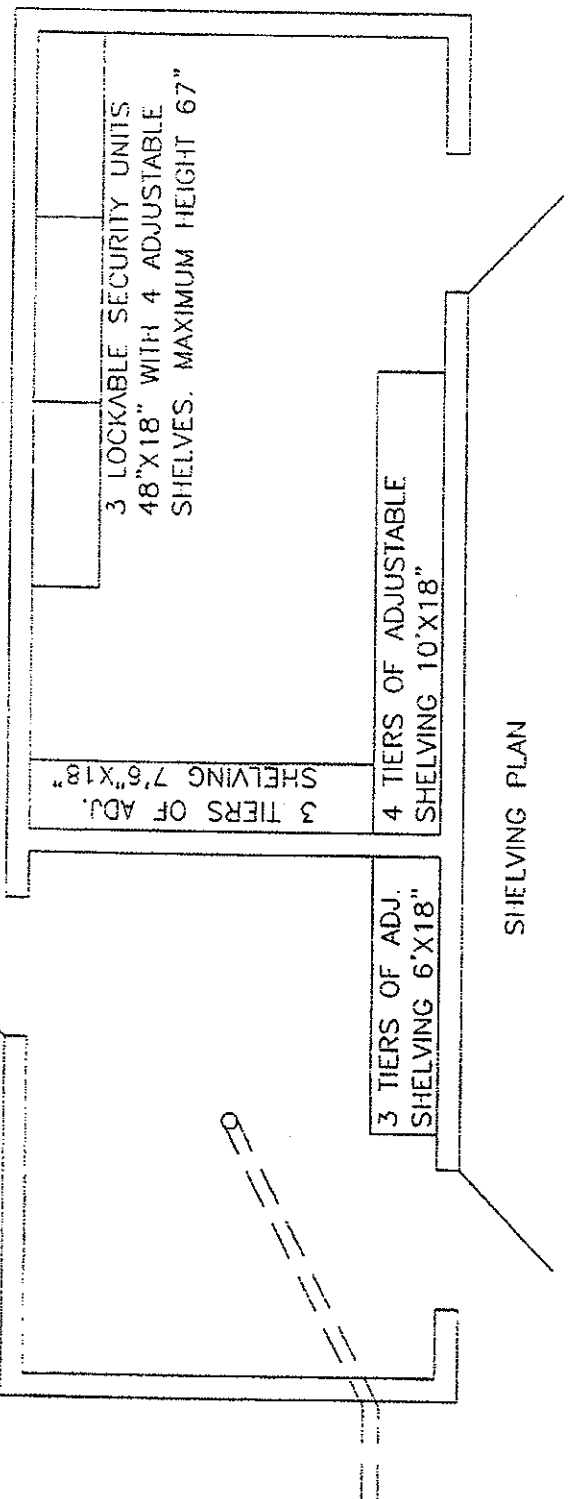

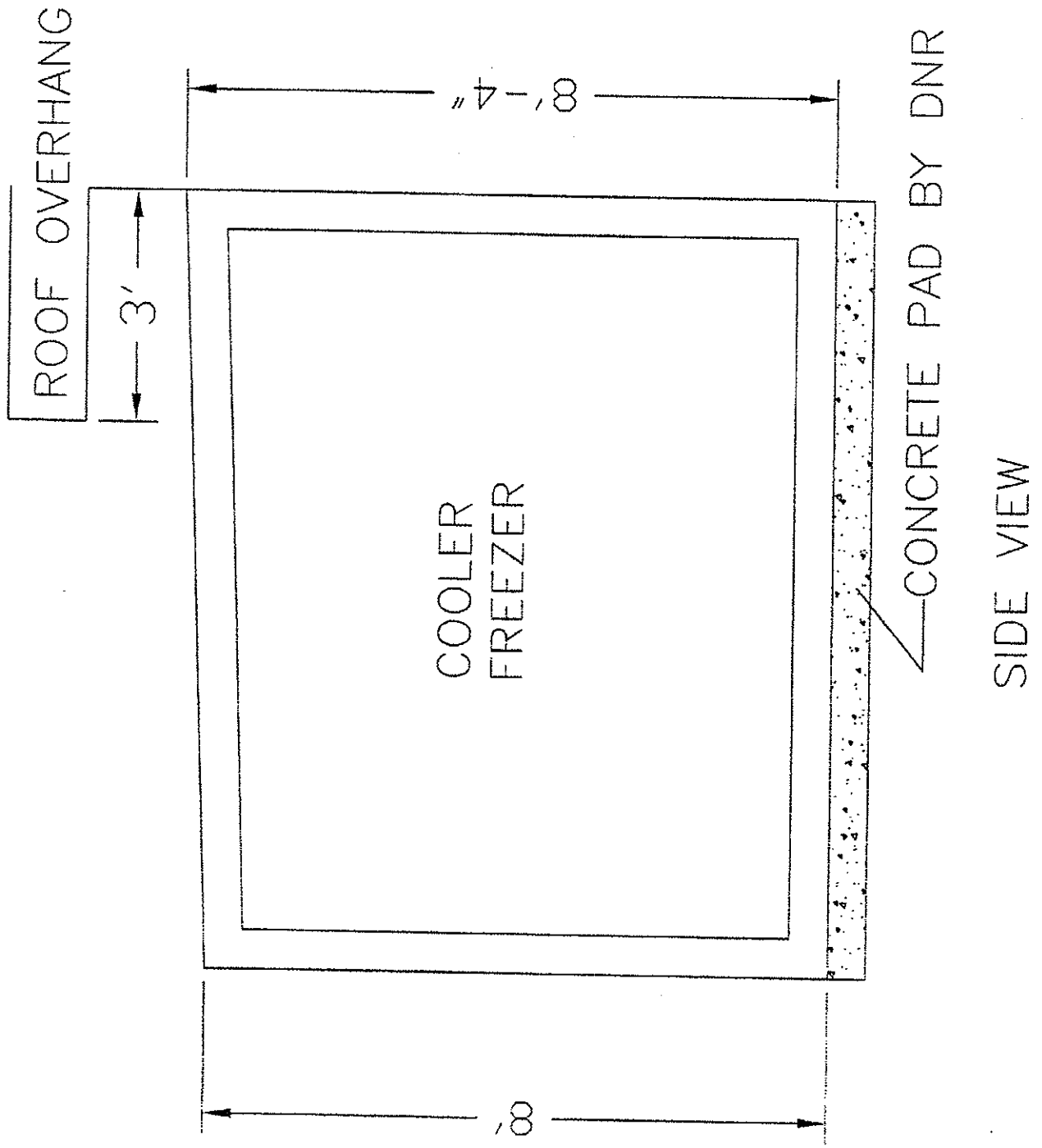

Single-Unit Cooler and Freezer Manufacturer's List

Please complete the below information concerning the brand(s) of equipment being bid in relation to this project. If bidding "or equal" brands, please attach manufacturer's literature documenting that it meets the mandatory requirements stated in the specifications. Vendors should note the areas of the provided manufacturer's literature that adheres to the mandatory requirements outlined in the Request for Quotation.

ITEM NO.	EQUIPMENT	MANUFACTURER	MODEL
1	Single-Unit Walk-in Cooler and Freezer	<i>Polar King</i>	<i>HM1030</i>

SINGLE-UNIT WALK-IN COOLER AND FREEZER
PRICING SHEET

ITEM NO.	QUANTITY	DESCRIPTION	UNIT PRICE	AMOUNT
1	1	Single-Unit Walk-in Cooler and Freezer		
			TOTAL COST	52,294. ¹⁶



February 7, 2011

Frank Whittaker
Department of Administration
Purchasing Division
Building 15
2019 Washington Street East
Charleston, WV 25305-0130

RE: RFQ # DNR211088 / Bid Opening Date: 2/15/2011

Dear Frank,

Our proposal is submitted in reply to your RFQ. However, please note please note the following deviations relative to the RFQ Specifications:

1. The floor drain will exit the walk-in parallel to the long wall. We will provide a 4' length of PVC pipe and a 90 degree elbow so that it can be routed to the discharge location specified in the specifications. (This is necessary because our frame rails do not allow us to run a drain line at an angle other than parallel or perpendicular to our frame rails).
2. The shelving along the left short wall of the freezer is only 7' long (not the 7'-6" specified). This is because a longer shelving will not fit (as shown in the DRN provided drawing).
3. This cooler/freezer includes a 5-year compressor warranty per our Conditions of Sale.

Thank you for your consideration and please call me with any questions.

Best Regards,

Brian Markham
Regional Sales Manager
Toll Free: 800-772-7178 xt 2551
Direct: 260-428-2551



PROPOSAL

Frank Whittaker
 West Virginia - DNR
 Ward Road
 Elkins, WV 26241

2/3/2011

Project Name: RFQ DNR211088
Model Number: HM1030 **Installation:** Through Wall **Proposal Number:** 13148.2

Standard Equipment:

seamless fiberglass interior and exterior
 hasp lock (ext. door)
 safety release handle
 lockable door latch
 self-closing hinges
 heated door jamb
 magnetic gasket
 door closer
 sweep seal
 208-230/1/60 refrigeration system
 low ambient controls
 defrost timer
 heated relief port (freezers)
 light switch/pilot light
 exterior color choice
 rain cap exterior doors
 remote thermometer
 interior lighting
 crowned roof
 heated freezer door

Included Optional Equipment:

1 Sloped Roof
 1 5 Inch Insulation
 1 Extra 36" Door
 1 Vinyl Strip Door
 2 Spring Loaded Hinges
 1 Exterior Door Ramp
 1 Metroseal 3 Shelving package per drawing
 1 6" Roof Insulation
 30 Linear Feet - Roof Flashing Kit (to be installed on site by others at purchasers expense)
 1 Side Wall Flashing Kit (to be installed on site by others at purchasers expense)
 50 Linear Feet - Exterior Base Skirting Kit (to be installed on site by others at purchasers expense)
 1 Floor Drain
 2 Three Way Light Switch in Cooler
 1 7 Ft Ceiling

Color Choices (choose one):

_____ safety white
 _____ light grey
 _____ beige
 _____ dunes tan

Or choose a palette number from one of the following manufacturers.

ICI/Glidden # _____
 Benjamin Moore # _____
 Sherwin Williams # _____

PRICING/DELIVERY

Freight To: Elkins, WV

Approximate Delivery: 4 to 6 Weeks
Payment Terms: 30% Down; NET 30

Unit Price : \$ 45,523.08
Shelving Cost (Installed) : \$ 4,294.08
Sales Tax : \$ 0.00
Shipping/Set-in-Place : \$ 2,477.00
Total Price : \$ 52,294.16

See Attached Polar King Conditions of Sale

This Proposal Valid for 60 Days

An Authorized Representative Shall Initial Page 1 of This Proposal and Sign Page 2 of This Proposal.

initial: _____



Polar King[®]

INTERNATIONAL INC.

Polar King Conditions of Sale

Proposal Number: 13148.2

GENERAL. Acceptance of this Proposal is expressly conditioned upon Buyer's assent to the Polar King International, Inc. (PKI) Conditions of Sale as set forth below and this Proposal may not be assigned. PKI agrees to furnish the equipment and services only upon these conditions. The Proposal and the following conditions shall constitute the entire agreement between PKI and Buyer, notwithstanding the terms and conditions of any purchase order of the Buyer. Any changes to this Proposal or to the Conditions of Sale shall be reduced to writing and agreed to by PKI.

DELIVERY. All equipment manufactured, assembled or warehoused in the continental United States is delivered F.O.B. shipping point. Where the scheduled delivery of equipment is delayed by Buyer or by Force Majeure, PKI may deliver the equipment by moving it to storage for the account of and at the risk of Buyer. Shipping dates are based upon prompt receipt of all necessary information and approvals from Buyer. All delivery dates are approximate. Claims for shortages or other errors in delivery must be made in writing to PKI within ten days of delivery. Customer will be responsible for providing clear access to delivery site for Polar King to unload and set-the-equipment in place.

PAYMENT - TITLE. Except as set forth in the proposal for this order or otherwise agreed to by PKI in writing, payment terms are net 30 days from date of shipment. If Buyer delays delivery, payment shall become due on the date PKI is prepared to ship. If payments are not made when due, Buyer shall pay a late charge equal to 1 1/2% per month (18% per annum) on all such overdue amounts. Buyer shall pay attorney fees and court costs incurred by PKI in collection of overdue payments. Title to the equipment sold shall remain with PKI until fully paid for in cash.

FORCE MAJEURE. PKI shall not be liable for loss, damage, or delay, nor be deemed to be in default from causes beyond its reasonable control or from fire, strikes, floods, tornados, earthquakes, hurricanes, war, sabotage, labor difficulties, act or omission of any governmental authority, compliance with import or export regulations, insurrection, riot, embargo, delays or shortages in transportation or inability to obtain necessary labor, materials or manufacturing facilities from usual sources, or from delays in the performance of its suppliers due to any of the foregoing causes. In the event of delay due to any such cause, the time for performance will be extended by a period of time equal to the time lost by reason of such delay and other affected contract provisions shall be equitably adjusted.

EQUIPMENT WARRANTY. PKI warrants that the equipment shall be free from defects in material and workmanship (for units installed and operated within the (48) contiguous states of the United States of America) as follows: The warranty period for the fiberglass structure and the door of the unit shall be for a period of ten years from the date of delivery. The warranty period for the refrigeration, electrical and mechanical systems shall be one year from date of delivery, if installed by PKI. The warranty period for door hardware, gaskets, heat tape and finishes shall be for a period of one year from the date of delivery. The warranty period for the compressor is five years from date of delivery. Should any failure to conform to the applicable warranty appear during the specified period, PKI will repair, replace or modify the defective part or parts. Repairs or replacements pursuant to the warranty shall not extend the original equipment warranty period. PKI shall not be responsible for providing working access to the defect. PKI warrants that the services of its personnel, if provided, will be performed in a workmanlike manner. Should a failure to conform arise during the applicable warranty period, Buyer agrees to promptly notify PKI to arrange for service of the defective part. This warranty shall not apply to any equipment or parts, which have been improperly installed, repaired or altered, have been subjected to misuse, negligence or accident; or have been used in a manner contrary to PKI operating and maintenance procedures. The above warranties and remedies are exclusive and in lieu of any and all representations, specifications, warranties and remedies either express or implied, herein or elsewhere, or which might arise under law or equity or custom of trade including without limitation warranties of merchantability and of fitness of a specified or intended purpose. The remedy specified represents the sole liability of PKI and the sole remedy of the Buyer with respect to or arising out of the equipment or services whether based on contract, tort (including negligence and strict liability), or otherwise.

LIMITATIONS OF LIABILITY. In no event shall PKI or its suppliers be liable, whether arising under performance of this contract, breach of this contract, or otherwise, for loss of anticipated profits, loss by reason of shutdown, non-operation, increased expense of operation, service interruptions, product loss, cost of money, loss of use of capital or revenue, or for any special, incidental or consequential loss or damage. PKI's liability on any claim of any kind, including negligence or strict liability, for any loss or damage arising out of, or resulting from this contract, or from its performance or breach, or from the manufacture, sale, delivery, resale, installation, startup or inspection, repair, operation, or use of any equipment covered by or furnished under this contract shall in no case exceed the purchase price allocable to the equipment, part, or service which gives rise to the claim. In no event, regardless of cause, shall PKI assume responsibility for or be liable for penalties or penalty clauses of any kind or for indemnification of customer or others for costs, damages, or expenses each arising out of or related to the goods or services of this order.

TAXES. The price does not include any federal, state or local property, sales, use, excise, gross receipts, franchise, or other like taxes which may now or hereafter be applicable to or imposed upon or with respect to the transaction, the property, its sale, its value or its use, or any services performed in connection herewith. Buyer agrees to pay or reimburse any such taxes which PKI or its suppliers are required to pay or collect.

PROPRIETARY INFORMATION - CONFIDENTIALITY. Any specifications, design, drawings, plans, notes, technical data or other information or materials of PKI submitted to the Buyer remain the exclusive property of PKI and may not, without its consent, be copied or communicated to a third party.

CANCELLATION. Any order or contract may be terminated by Buyer only upon written notice and payment of reasonable and proper termination charges, including but not limited to all costs identified to the order or contract incurred up to the later of the date of the notice or PKI's receipt of the notice of termination and all charges incurred by PKI in respect to the termination, plus 10% of the final net selling price.

PARTIAL INVALIDITY. If any provision herein or portion thereof shall for any reason be held invalid or unenforceable, such invalidity or unenforceability shall not affect any other provisions or portion thereof, but these Conditions of Sale shall be construed as if such invalid or unenforceable provision or portion thereof had never been contained herein.

CHOICE OF LAW. The laws of the State of Indiana shall govern this agreement.

INVENTIONS, PATENTS, TRADEMARKS, COPYRIGHTS. PKI warrants that the equipment purchased hereunder shall be delivered free of rightful claims for infringement of any United States patent or trademark, provided however that where equipment is manufactured from patterns, plans, drawings or specifications furnished by Buyer, Buyer shall indemnify PKI against and hold harmless PKI from all loss, damage, and expense arising out of any suit or claim against PKI for infringement of any patent, trademark, or copyright because of PKI's manufacture of such equipment or because of the use or sale of such equipment by any person. All right, title and interest in any inventions, developments, improvements or modifications of or for equipment or services furnished to the Buyer shall remain with PKI unless otherwise agreed to in writing between the parties.

Signature: *Brian Markham*
Brian Markham

Signature: _____
Frank Whittaker

Date: _____

ROOM TEMP.: 35°F
 INTERIOR AREA: 106 sq. ft.
 INTERIOR VOLUME: 742 cu. ft.
 HORSEPOWER: 1 1/4 hp.
 REFRIGERANT: R-404A
 ELEC. SUPPLY: 208-230/110
 PHASE: Single
 CYCLE: 60 Hz.
 AMPERAGE: 14.3 MCA

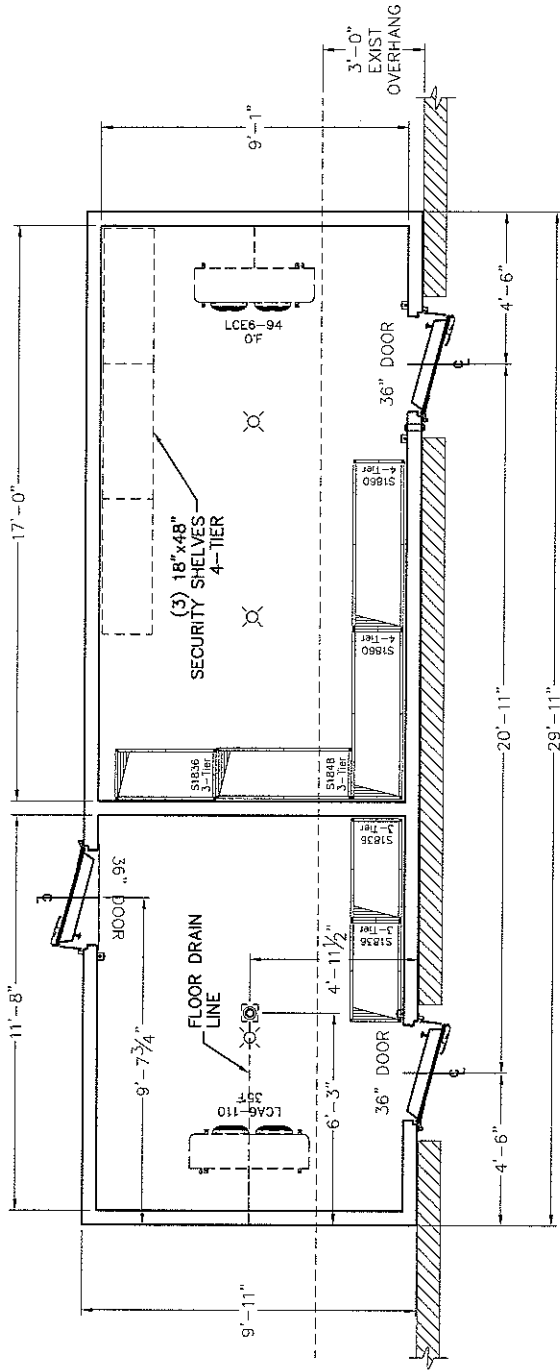

PLAN VIEW

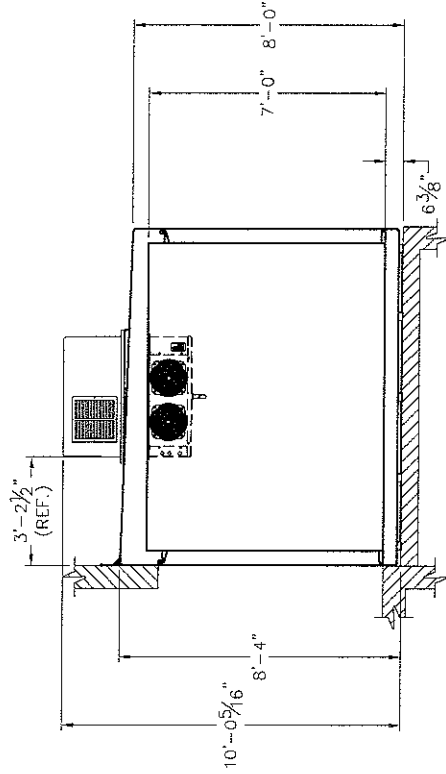

SECTION VIEW

FLOOR DRAIN (COOLER)
 5" WALL INSULATION
 10" TO 6" ROOF INSULATION
 VINYL STRIP CURTAIN (EXTERIOR DOOR)
 SPRING HINGES (INTERIOR DOORS)

DRAWING APPROVAL

PLEASE INDICATE YOUR APPROVAL OF THIS DESIGN, THE DIMENSIONS, DOOR LOCATION/SWING, ELECTRICAL REQUIREMENTS AND EQUIPMENT LOCATIONS BY SIGNING BELOW AND RETURNING TO POLAR KING.

DATE: _____ BY: _____

West Virginia DNR

Elkins, West Virginia

DRAWN BY: RDA MODEL NO.: HM1030 SCALE: 3/16" = 1'-0" DATE: 1-31-11

DRAWING NAME: West Virginia DNR HM1030 Elkins WV B



FORT WAYNE, INDIANA 1-800-752-7178

THE REFRIGERATION SYSTEM SHOWN IS DESIGNED TO MAINTAIN INDICATED TEMPERATURE IF PRODUCT ENTERS WITHIN 10°F OF FINAL HOLDING TEMPERATURE. PLEASE CONTACT YOUR SALES REP IF INCOMING PRODUCT WILL BE ENTERING AT HIGHER TEMPERATURES.

VENDOR PREFERENCE CERTIFICATE

Certification and application* is hereby made for Preference in accordance with **West Virginia Code**, §5A-3-37. (Does not apply to construction contracts). **West Virginia Code**, §5A-3-37, provides an opportunity for qualifying vendors to request (at the time of bid) preference for their residency status. Such preference is an evaluation method only and will be applied only to the cost bid in accordance with the **West Virginia Code**. This certificate for application is to be used to request such preference. The Purchasing Division will make the determination of the Resident Vendor Preference, if applicable.

1. Application is made for 2.5% resident vendor preference for the reason checked:

- Bidder is an individual resident vendor and has resided continuously in West Virginia for four (4) years immediately preceding the date of this certification; **or**,
- Bidder is a partnership, association or corporation resident vendor and has maintained its headquarters or principal place of business continuously in West Virginia for four (4) years immediately preceding the date of this certification; or 80% of the ownership interest of Bidder is held by another individual, partnership, association or corporation resident vendor who has maintained its headquarters or principal place of business continuously in West Virginia for four (4) years immediately preceding the date of this certification; **or**,
- Bidder is a nonresident vendor which has an affiliate or subsidiary which employs a minimum of one hundred state residents and which has maintained its headquarters or principal place of business within West Virginia continuously for the four (4) years immediately preceding the date of this certification; **or**,

2. Application is made for 2.5% resident vendor preference for the reason checked:

- Bidder is a resident vendor who certifies that, during the life of the contract, on average at least 75% of the employees working on the project being bid are residents of West Virginia who have resided in the state continuously for the two years immediately preceding submission of this bid; **or**,

3. Application is made for 2.5% resident vendor preference for the reason checked:

- Bidder is a nonresident vendor employing a minimum of one hundred state residents or is a nonresident vendor with an affiliate or subsidiary which maintains its headquarters or principal place of business within West Virginia employing a minimum of one hundred state residents who certifies that, during the life of the contract, on average at least 75% of the employees or Bidder's affiliate's or subsidiary's employees are residents of West Virginia who have resided in the state continuously for the two years immediately preceding submission of this bid; **or**,

4. Application is made for 5% resident vendor preference for the reason checked:

- Bidder meets either the requirement of both subdivisions (1) and (2) or subdivision (1) and (3) as stated above; **or**,

5. Application is made for 3.5% resident vendor preference who is a veteran for the reason checked:

- Bidder is an individual resident vendor who is a veteran of the United States armed forces, the reserves or the National Guard and has resided in West Virginia continuously for the four years immediately preceding the date on which the bid is submitted; **or**,

6. Application is made for 3.5% resident vendor preference who is a veteran for the reason checked:

- Bidder is a resident vendor who is a veteran of the United States armed forces, the reserves or the National Guard, if, for purposes of producing or distributing the commodities or completing the project which is the subject of the vendor's bid and continuously over the entire term of the project, on average at least seventy-five percent of the vendor's employees are residents of West Virginia who have resided in the state continuously for the two immediately preceding years.

Bidder understands if the Secretary of Revenue determines that a Bidder receiving preference has failed to continue to meet the requirements for such preference, the Secretary may order the Director of Purchasing to: (a) reject the bid; or (b) assess a penalty against such Bidder in an amount not to exceed 5% of the bid amount and that such penalty will be paid to the contracting agency or deducted from any unpaid balance on the contract or purchase order.

By submission of this certificate, Bidder agrees to disclose any reasonably requested information to the Purchasing Division and authorizes the Department of Revenue to disclose to the Director of Purchasing appropriate information verifying that Bidder has paid the required business taxes, provided that such information does not contain the amounts of taxes paid nor any other information deemed by the Tax Commissioner to be confidential.

Under penalty of law for false swearing (West Virginia Code, §61-5-3), Bidder hereby certifies that this certificate is true and accurate in all respects; and that if a contract is issued to Bidder and if anything contained within this certificate changes during the term of the contract, Bidder will notify the Purchasing Division in writing immediately.

Bidder: Polar King International Signed: J. Mauleham
 Date: 2-7-11 Title: Regional Sales Manager

*Check any combination of preference consideration(s) indicated above, which you are entitled to receive.

All are not applicable.

*All N/A.
BWA 2-7-11*

RFQ No. DNR 211088

STATE OF WEST VIRGINIA
Purchasing Division

PURCHASING AFFIDAVIT

West Virginia Code §5A-3-10a states: No contract or renewal of any contract may be awarded by the state or any of its political subdivisions to any vendor or prospective vendor when the vendor or prospective vendor or a related party to the vendor or prospective vendor is a debtor and the debt owed is an amount greater than one thousand dollars in the aggregate.

DEFINITIONS:

"Debt" means any assessment, premium, penalty, fine, tax or other amount of money owed to the state or any of its political subdivisions because of a judgment, fine, permit violation, license assessment, defaulted workers' compensation premium, penalty or other assessment presently delinquent or due and required to be paid to the state or any of its political subdivisions, including any interest or additional penalties accrued thereon.

"Debtor" means any individual, corporation, partnership, association, limited liability company or any other form or business association owing a debt to the state or any of its political subdivisions. "Political subdivision" means any county commission; municipality; county board of education; any instrumentality established by a county or municipality; any separate corporation or instrumentality established by one or more counties or municipalities, as permitted by law; or any public body charged by law with the performance of a government function or whose jurisdiction is coextensive with one or more counties or municipalities. "Related party" means a party, whether an individual, corporation, partnership, association, limited liability company or any other form or business association or other entity whatsoever, related to any vendor by blood, marriage, ownership or contract through which the party has a relationship of ownership or other interest with the vendor so that the party will actually or by effect receive or control a portion of the benefit, profit or other consideration from performance of a vendor contract with the party receiving an amount that meets or exceed five percent of the total contract amount.

EXCEPTION: The prohibition of this section does not apply where a vendor has contested any tax administered pursuant to chapter eleven of this code, workers' compensation premium, permit fee or environmental fee or assessment and the matter has not become final or where the vendor has entered into a payment plan or agreement and the vendor is not in default of any of the provisions of such plan or agreement.

Under penalty of law for false swearing (*West Virginia Code* §61-5-3), it is hereby certified that the vendor affirms and acknowledges the information in this affidavit and is in compliance with the requirements as stated.

WITNESS THE FOLLOWING SIGNATURE

Vendor's Name: Polar King International Inc.

Authorized Signature: [Signature] Date: 2-7-11

State of Indiana

County of Allen, to-wit:

Taken, subscribed, and sworn to before me this 7 day of February, 2011.

My Commission expires 1-16-16.

AFFIX SEAL HERE

NOTARY PUBLIC

[Signature]

RITA KNOTHE

Resident of Allen County, Indiana