



State of West Virginia
 Department of Administration
 Purchasing Division
 2019 Washington Street East
 Post Office Box 50130
 Charleston, WV 25305-0130

Request for Quotation

RFQ NUMBER
DNR210242

PAGE
1

ADDRESS CORRESPONDENCE TO ATTENTION OF:
FRANK WHITTAKER 304-558-2316

RFQ COPY

TYPE NAME/ADDRESS HERE

Thomas W. Raftery, Inc.
 1055 Broad Street
 Hartford CT 06106
 1-800-243-2887

SHIP TO

DIVISION OF NATURAL RESOURCES
 TWIN FALLS RESORT
 ATTN: PARK SUPERINTENDENT
 RT. 97, PO BOX 667
 MULLENS, WV
 25882 304-294-6000

DATE PRINTED	TERMS OF SALE	SHIP VIA	F.O.B.	FREIGHT TERMS
07/20/2010	Net 30	Best Carrier	Destination	Included in pricing

BID OPENING DATE: 08/25/2010 BID OPENING TIME 01:30PM

LINE	QUANTITY	UOP	CAT NO	ITEM NUMBER	UNIT PRICE	AMOUNT
0001	1	LS		870-90		\$33,664.87
<p>WINDOW BLINDS</p> <p>THE WEST VIRGINIA PURCHASING DIVISION, FOR THE AGENCY, THE WEST VIRGINIA DIVISION OF NATURAL RESOURCES, IS SOLICITING BIDS FROM RESPONSIBLE VENDORS TO PROVIDE AND INSTALL WINDOW BLINDS A TWIN FALLS RESORT STATE PARK PER THE ATTACHED SPECIFICATIONS.</p> <p>ALL TECHNICAL QUESTIONS MUST BE SUBMITTED IN WRITING TO FRANK WHITTAKER IN THE WV PURCHASING DIVISION VIA EMAIL AT FRANK.M.WHITTAKER@WV.GOV OR VIA FAX AT 304-558-4115. DEADLINE FOR ALL TECHNICAL QUESTIONS IS 08/04/2010. ALL TECHNICAL QUESTIONS WILL BE ADDRESSED BY ADDENDUM AFTER THE DEADLINE.</p> <p>BANKRUPTCY: IN THE EVENT THE VENDOR/CONTRACTOR FILES FOR BANKRUPTCY PROTECTION, THE STATE MAY DEEM THE CONTRACT NULL AND VOID, AND TERMINATE SUCH CONTRACT WITHOUT FURTHER ORDER.</p> <p style="text-align: center;">NOTICE</p> <p>A SIGNED BID MUST BE SUBMITTED TO:</p> <p style="text-align: center;">DEPARTMENT OF ADMINISTRATION PURCHASING DIVISION BUILDING 15 2019 WASHINGTON STREET, EAST CHARLESTON, WV 25305-0130</p>						

RECEIVED
 2010 JUL 29 PM 3:13
 WV PURCHASING DIVISION

Digitally signed by Allison Calca email=allison@twraftery.com, c=US Date: 2010.07.26 14:27:26 -0400		SEE REVERSE SIDE FOR TERMS AND CONDITIONS	
SIGNATURE	TELEPHONE	DATE	
<i>Allison Calca</i>	1-800-243-2887	7/27/10	
TITLE	FEIN	ADDRESS CHANGES TO BE NOTED ABOVE	
Sales & Marketing	060813877		

WHEN RESPONDING TO RFQ, INSERT NAME AND ADDRESS IN SPACE ABOVE LABELED 'VENDOR'

GENERAL TERMS & CONDITIONS REQUEST FOR QUOTATION (RFQ) AND REQUEST FOR PROPOSAL (RFP)

1. Awards will be made in the best interest of the State of West Virginia.
 2. The State may accept or reject in part, or in whole, any bid.
 3. Prior to any award, the apparent successful vendor must be properly registered with the Purchasing Division and have paid the required \$125 fee.
 4. All services performed or goods delivered under State Purchase Order/Contracts are to be continued for the term of the Purchase Order/Contracts, contingent upon funds being appropriated by the Legislature or otherwise being made available. In the event funds are not appropriated or otherwise available for these services or goods this Purchase Order/Contract becomes void and of no effect after June 30.
 5. Payment may only be made after the delivery and acceptance of goods or services.
 6. Interest may be paid for late payment in accordance with the *West Virginia Code*.
 7. Vendor preference will be granted upon written request in accordance with the *West Virginia Code*.
 8. The State of West Virginia is exempt from federal and state taxes and will not pay or reimburse such taxes.
 9. The Director of Purchasing may cancel any Purchase Order/Contract upon 30 days written notice to the seller.
 10. The laws of the State of West Virginia and the *Legislative Rules* of the Purchasing Division shall govern the purchasing process.
 11. Any reference to automatic renewal is hereby deleted. The Contract may be renewed only upon mutual written agreement of the parties.
 12. **BANKRUPTCY:** In the event the vendor/contractor files for bankruptcy protection, the State may deem this contract null and void, and terminate such contract without further order.
 13. **HIPAA BUSINESS ASSOCIATE ADDENDUM:** The West Virginia State Government HIPAA Business Associate Addendum (BAA), approved by the Attorney General, is available online at www.state.wv.us/admin/purchase/vro/hipaa.htm and is hereby made part of the agreement. Provided that the Agency meets the definition of a Cover Entity (45 CFR §160.103) and will be disclosing Protected Health Information (45 CFR §160.103) to the vendor.
 14. **CONFIDENTIALITY:** The vendor agrees that he or she will not disclose to anyone, directly or indirectly, any such personally identifiable information or other confidential information gained from the agency, unless the individual who is the subject of the information consents to the disclosure in writing or the disclosure is made pursuant to the agency's policies, procedures, and rules. Vendor further agrees to comply with the Confidentiality Policies and Information Security Accountability Requirements, set forth in <http://www.state.wv.us/admin/purchase/privacy/noticeConfidentiality.pdf>.
 15. **LICENSING:** Vendors must be licensed and in good standing in accordance with any and all state and local laws and requirements by any state or local agency of West Virginia, including, but not limited to, the West Virginia Secretary of State's Office, the West Virginia Tax Department, and the West Virginia Insurance Commission. The vendor must provide all necessary releases to obtain information to enable the director or spending unit to verify that the vendor is licensed and in good standing with the above entities.
 16. **ANTITRUST:** In submitting a bid to any agency for the State of West Virginia, the bidder offers and agrees that if the bid is accepted the bidder will convey, sell, assign or transfer to the State of West Virginia all rights, title and interest in and to all causes of action it may now or hereafter acquire under the antitrust laws of the United States and the State of West Virginia for price fixing and/or unreasonable restraints of trade relating to the particular commodities or services purchased or acquired by the State of West Virginia. Such assignment shall be made and become effective at the time the purchasing agency tenders the initial payment to the bidder.
- I certify that this bid is made without prior understanding, agreement, or connection with any corporation, firm, limited liability company, partnership, or person or entity submitting a bid for the same material, supplies, equipment or services and is in all respects fair and without collusion or fraud. I further certify that I am authorized to sign the certification on behalf of the bidder or this bid.

INSTRUCTIONS TO BIDDERS

1. Use the quotation forms provided by the Purchasing Division. Complete all sections of the quotation form.
2. Items offered must be in compliance with the specifications. Any deviation from the specifications must be clearly indicated by the bidder. Alternates offered by the bidder as EQUAL to the specifications must be clearly defined. A bidder offering an alternate should attach complete specifications and literature to the bid. The Purchasing Division may waive minor deviations to specifications.
3. Unit prices shall prevail in case of discrepancy. All quotations are considered F.O.B. destination unless alternate shipping terms are clearly identified in the quotation.
4. All quotations must be delivered by the bidder to the office listed below prior to the date and time of the bid opening. Failure of the bidder to deliver the quotations on time will result in bid disqualifications: Department of Administration, Purchasing Division, 2019 Washington Street East, P.O. Box 50130, Charleston, WV 25305-0130
5. Communication during the solicitation, bid, evaluation or award periods, except through the Purchasing Division, is strictly prohibited (W.Va. C.S.R. §148-1-6.6).



State of West Virginia
 Department of Administration
 Purchasing Division
 2019 Washington Street East
 Post Office Box 50130
 Charleston, WV 25305-0130

**Request for
 Quotation**

RFQ NUMBER
DNR210242

PAGE
2

ADDRESS CORRESPONDENCE TO ATTENTION OF:
**FRANK WHITTAKER
 304-558-2316**

RFQ COPY

TYPE NAME/ADDRESS HERE

SHIP TO

**DIVISION OF NATURAL RESOURCES
 TWIN FALLS RESORT
 ATTN: PARK SUPERINTENDENT
 RT. 97, PO BOX 667
 MULLENS, WV
 25882 304-294-6000**

DATE PRINTED 07/20/2010	TERMS OF SALE Net 30	SHIP VIA Best Carrier	FOB Destination	FREIGHT TERMS Included in pricing
-----------------------------------	-------------------------	--------------------------	--------------------	--------------------------------------

BID OPENING DATE: **08/25/2010** BID OPENING TIME **01:30PM**

LINE	QUANTITY	UQP	CAT NO.	ITEM NUMBER	UNIT PRICE	AMOUNT
<p>THE BID SHOULD CONTAIN THIS INFORMATION ON THE FACE OF THE ENVELOPE OR THE BID MAY NOT BE CONSIDERED:</p> <p>SEALED BID</p> <p>BUYER: 44</p> <p>RFQ. NO.: DNR210242</p> <p>BID OPENING DATE: 08/25/2010</p> <p>BID OPENING TIME: 1:30 PM</p> <p>PLEASE PROVIDE A FAX NUMBER IN CASE IT IS NECESSARY TO CONTACT YOU REGARDING YOUR BID:</p> <p>-----</p> <p>CONTACT PERSON (PLEASE PRINT CLEARLY):</p> <p>-----</p>						
<p>***** THIS IS THE END OF RFQ DNR210242 ***** TOTAL:</p>						<p><u>\$33,664.87</u></p>

SEE REVERSE SIDE FOR TERMS AND CONDITIONS

SIGNATURE: Allison Calca *Allison Calca* TELEPHONE: 1-800-243-2887 DATE: 7/27/10

TITLE: Sales & Marketing FEIN: 060813877 ADDRESS CHANGES TO BE NOTED ABOVE

WHEN RESPONDING TO RFQ, INSERT NAME AND ADDRESS IN SPACE ABOVE LABELED 'VENDOR'

Supply and Install Window Blinds at Twin Falls State Park**SPECIFICATIONS AND SCOPE OF WORK****Scope of Work:**

The West Virginia Division of Natural Resources; hereinafter Division is accepting Bids for the purchase and installation of window shades for its new twenty-seven guest room addition and the purchase and installation of window shades for the Azalea, Chinquapin, and Dogwood conference rooms as well as the lodge office and fitness center. All items are to be F.O.B. Destination. Freight or delivery charges must be included in the price of the line item cost. Vendor must provide all necessary labor, materials, supervision, tools, equipment and hardware to properly install the blinds as per the manufacturer's recommendations. Vendor must provide inventory recommendations for maintenance, cleaning and upkeep.

Pre-bid Meeting:

A pre-bid meeting is not necessary for this project; however, the Vendors should make arrangements with the Park Superintendent or Assistant Park Superintendent for a site visit to individually field measure each window and door to ensure proper fit and operation.

Basis of Award:

The Contract will be awarded to the lowest qualified Vendor submitting the lowest total Bid for all of the items on the Bid Schedule and in complete accordance with all specifications stipulated herein.

Coordination:

Vendor must coordinate timing of the installation with the Division's Authorized Representative per the contact information below to limit and minimize any inconveniences to lodge guests. All aspects of this contract must be coordinated with the Division's Authorized Representative(s). All work pursuant to this contract shall be completed within thirty days after coordination.

Division's Authorized Representative:

Scott Durham
Park Superintendent
Twin Falls State Park

Nathan Hanshaw
Assistant Park Superintendent
Twin Falls State Park

Supply and Install Window Blinds at Twin Falls State Park**Inspection:**

All items must be inspected by the Division subsequent to delivery to ensure that each item is not damaged or defective. Damaged or defective items must be rejected, removed, and replaced at no additional expense to the Division. Vendor must be responsible for damages that occur during assembly and set-up.

Project Closeout:

Vendor must provide inventory recommendations for maintenance, cleaning and upkeep.

Safety:

Successful Vendor will be working in public areas where guests and employees will be present. The successful Vendor is therefore required to maintain a safe, clean, and orderly Work area at all times.

Warranty Period:

Vendor must warranty that the equipment contained in this Bid is intended and manufactured for commercial use and must be free of defects in materials and Workmanship for a period of one year after date of acceptance. Vendor must repair or replace, at its discretion, free of charge, any product that proves to be defective during the Warranty Period. However, if manufacturer warranty periods are longer than the required minimum listed above, then those warranties must prevail.

General Window Shade Specifications

1. Shades must be a cordless lift and lower system for all guest room windows and doors, offices, and hallways
2. Shades must be a continuous cord loop and clutch system for Chinquapin, Azalea, and Dogwood Conference Room, and must include side channels.
3. Minimum 3/8" / Maximum 3/4" single cell shades for windows
4. Maximum 3/8" shades for doors in order to clear door hardware
5. Shades must be room darkening blackout (opaque) for all guest rooms
6. Shades must be room darkening blackout (opaque) for conference rooms
7. Shades must be semi-opaque for offices, hallways, and fitness center

Supply and Install Window Blinds at Twin Falls State Park

8. Shades must be fade resistant
9. Shades must be certified flame resistant for commercial use – NFPA 701
10. Available color options should be included with Bid

Manufacturer Disclosure:

Vendor should provide the manufacturer name and model number of the product that is being Bid.

Manufacturer: Hunter Douglas / Draper Shade

Model #: Hunter Douglas 3/4" Flame Retardant Duetto Pleated Shades in opaque fabric with LiteRise (Cordless) feature
Draper Shade
Draper LightBloc clutch shades w/ fascia, side & sill channels
in blackout SB9000 fabric

Supply and Install Window Blinds at Twin Falls State Park

Item No.	Quantity	Location	Unit	Total
1	1	Room 401- (window) 67 1/4" x 55 1/16" - opaque	\$ 452.00	\$ 452.00
2	1	Room 402 - (window) 67 1/4" x 55 1/16" - opaque	\$ 452.00	\$ 452.00
3	1	Room 403 - (window) 67 1/4" x 55 1/16" - opaque	\$ 452.00	\$ 452.00
4	1	Room 404 - (window) 67 1/4" x 55 3/16" - opaque	\$ 452.00	\$ 452.00
5	1	Room 405 - (window) 67 1/4" x 55 1/16" - opaque	\$ 452.00	\$ 452.00
6	1	Room 501- (window) 38 1/2" x 81 1/2" - opaque	\$ 363.00	\$ 363.00
7	1	Room 501- (window) 44 1/8" x 60 3/4" - opaque	\$ 341.00	\$ 341.00
8	1	Room 502 - (door) 30 7/8" x 75 7/8" - opaque	\$ 306.00	\$ 306.00
9	1	Room 502 (window) 44 1/8" x 60 3/4" - opaque	\$ 341.00	\$ 341.00
10	1	Room 503 - (window) 38 1/2" x 81 1/2" - opaque	\$ 363.00	\$ 363.00
11	1	Room 503 - (window) 44 1/8" x 60 7/8" - opaque	\$ 341.00	\$ 341.00
12	1	Room 504 - (door) 30 3/4" x 75 7/8" - opaque	\$ 306.00	\$ 306.00
13	1	Room 504 - (window) 44 3/16" x 60 3/4" - opaque	\$ 341.00	\$ 341.00
14	2	Room 505 - (window) 31 3/4" x 55 3/4" - opaque	\$ 258.00	\$ 516.00
15	2	Room 505 - (window) 31 3/4" x 22 15/16" - opaque	\$ 196.00	\$ 392.00
16	2	Room 506 - double doors -28 5/8" x 75 7/8" - opaque	\$ 265.00	\$ 530.00
17	1	Room 507 - (door) 30 3/4" x 75 7/8" - opaque	\$ 306.00	\$ 306.00
18	1	Room 507 - (window) 44 1/8" x 61" - opaque	\$ 341.00	\$ 341.00
19	1	Room 508 - (door) 30 3/4" x 75 7/8" - opaque	\$ 306.00	\$ 306.00
20	1	Room 508 - (window) 34 1/8" x 60 7/8" - opaque	\$ 274.00	\$ 274.00

Supply and Install Window Blinds at Twin Falls State Park

Item No.	Quantity	Location	Unit	Total
21	1	Room 509 - (door) 30 7/8" x 75 7/8" - opaque	\$ 306.00	\$306.00
22	1	Room 509 - (window) 44 1/8" x 60 3/4" - opaque	\$ 341.00	\$341.00
23	1	Room 510 - (door) 30 7/8" x 75 7/8" - opaque	\$ 306.00	\$306.00
24	1	Room 510 - (window) 44 1/8" x 60 3/4" - opaque	\$ 341.00	\$341.00
25	1	Room 511 - (door) 30 7/8" x 75 7/8" - opaque	\$306.00	\$ 306.00
26	1	Room 511 - (window) 44 1/8" x 60 3/4" - opaque	\$ 341.00	\$ 341.00
27	1	Room 601 - (door) 30 7/8" x 75 3/4" - opaque	\$ 306.00	\$ 306.00
28	1	Room 601 - (window) 44 1/8" x 60 7/8" - opaque	\$ 341.00	\$ 341.00
29	1	Room 602 - (door) 30 7/8" x 75 7/8" - opaque	\$ 306.00	\$306.00
30	1	Room 602 - (window) 44 1/8" x 60 7/8" - opaque	\$ 341.00	\$ 341.00
31	1	Room 603 - (door) 30 7/8" x 75 7/8" - opaque	\$ 306.00	\$306.00
32	1	Room 603 - (window) 44 1/8" x 60 7/8" - opaque	\$ 341.00	\$306.00
33	1	Room 604 - (door) 30 7/8" x 75 7/8" - opaque	\$ 306.00	\$ 306.00
34	1	Room 604 - (window) 44 1/8" x 60 7/8" - opaque	\$ 341.00	\$ 341.00
35	2	Room 605 - (double doors) 28 5/8" x 75 7/8" - opaque	\$ 265.00	\$ 530.00
36	2	Room 606 - (double doors) 28 5/8" x 75 7/8" - opaque	\$ 265.00	\$ 530.00
37	1	Room 607 - (door) 30 7/8" x 75 7/8" - opaque	\$ 306.00	\$ 306.00
38	1	Room 607 - (window) 44 1/8" x 60 7/8" - opaque	\$ 341.00	\$ 341.00
39	1	Room 608 - (door) 30 7/8" x 75 7/8" - opaque	\$ 306.00	\$ 306.00
40	1	Room 608 - (window) 44 1/8" x 60 7/8" - opaque	\$ 341.00	\$ 341.00

Supply and Install Window Blinds at Twin Falls State Park

Item No.	Quantity	Location	Unit	Total
41	1	Room 609 - (door) 30 7/8" x 75 7/8" - opaque	\$ 306.00	\$306.00
42	1	Room 609 - (window) 44 1/8" x 60 7/8" - opaque	\$ 341.00	\$ 341.00
43	1	Room 610 -(door) 30 7/8" x 75 7/8" - opaque	\$ 306.00	\$ 306.00
44	1	Room 610 - (window) 44 1/8" x 60 7/8" - opaque	\$ 341.00	\$ 341.00
45	1	Room 611 - (door) 30 7/8" x 75 7/8" - opaque	\$ 306.00	\$ 306.00
46	1	Room 611 - (window) 44 1/8" x 60 7/8" opaque	\$ 341.00	\$341.00
47	1	3rd Floor Hallway - (window) 43 1/2" x 43 1/8" - semi-opaque	\$ 325.00	\$325.00
48	1	Front Desk Office - (window) 67 3/16" x 55 1/16"- semi-opaque	\$ 452.00	\$ 452.00
49	1	Fitness Room - (window) 67 3/16" x 55 1/16" - semi-opaque	\$ 452.00	\$ 452.00
50	2	Azalea Conference Room - (single large window) 53 3/4" x 72 1/2" - opaque	\$ 930.30	\$ 930.30
51	2	Azalea Conference Room - (single large window) 53 3/4" X 37 3/4" - opaque	\$ 790.65	\$ 1,581.30
52	2	Dogwood Conference Room - (window) 67 1/4" x 55" - opaque	\$ 841.75	\$ 1,683.50
53	1	Chinaquapin Conference Room - (window) 41 7/8" x 80 7/8" - opaque	\$ 827.05	\$ 827.05
54	1	Chinaquapin Conference Room - (window) 52 3/16" x 82 1/8" - opaque	\$ 930.30	\$ 930.30
55	1	Chinaquapin Conference Room - (window) 49 7/8" x 82 3/8" - opaque	\$ 930.30	\$ 930.30
56	1	Chinaquapin Conference Room - (window) 50 3/16" x 82 3/8" - opaque	\$ 930.30	\$ 930.30
57	1	Chinaquapin Conference Room - (window) 50 3/16" x 82" - opaque	\$ 930.30	\$ 930.30
58	1	Chinaquapin Conference Room - (window) 49 7/8" x 82" - opaque	\$ 930.30	\$ 930.30
59	1	Chinaquapin Conference Room - (window) 50 3/16" x 81 3/4" - opaque	\$ 930.30	\$ 930.30
60	1	Chinaquapin Conference Room - (window) 50 1/8" x 81 1/8" - opaque	\$ 930.30	\$ 930.30

Supply and Install Window Blinds at Twin Falls State Park

Item No.	Quantity	Location	Unit	Total
61	1	Chinaquapin Conference Room - (window) 49 7/8" x 81 1/8" - opaque	\$ 930.30	\$ 930.30
62	1	Chinaquapin Conference Room - (window) 50 1/8" x 81 1/8" - opaque	\$ 930.30	\$ 930.30
63	1	Chinaquapin Conference Room - (window) 71 5/16" x 81 1/8" - opaque	\$ 935.90	\$ 935.90
64	1	Chinaquapin Conference Room - (window) 71 9/16" x 80 3/4" - opaque	\$ 935.90	\$ 935.90
65	1	Chinaquapin Conference Room - (entry door) - opaque 32 3/8" x 79"	\$ 753.55	\$ 753.22
GRAND TOTAL BID			\$	\$ 33,664.87

Duette® FR Honeycomb Shades

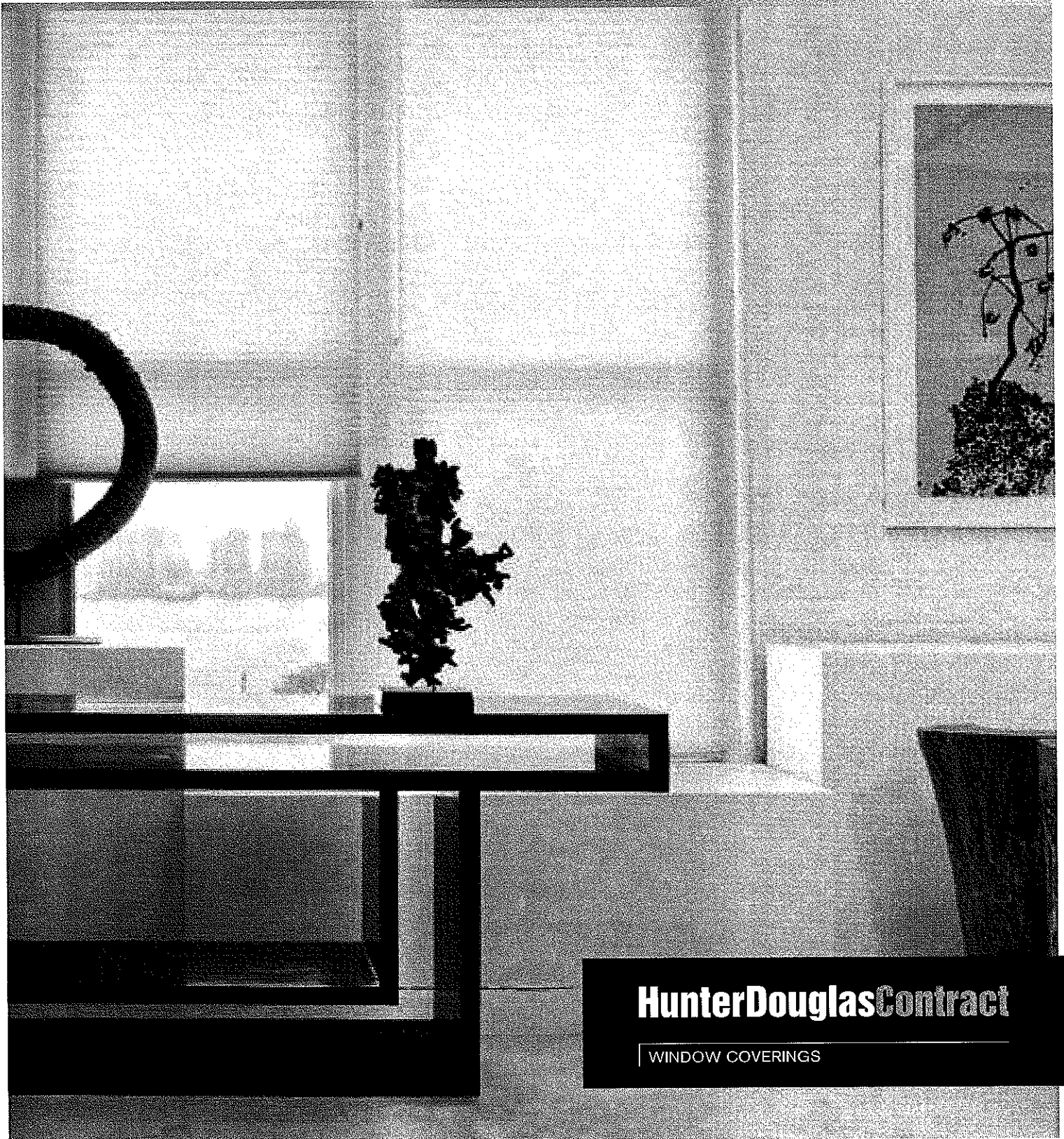

HunterDouglasContract

WINDOW COVERINGS

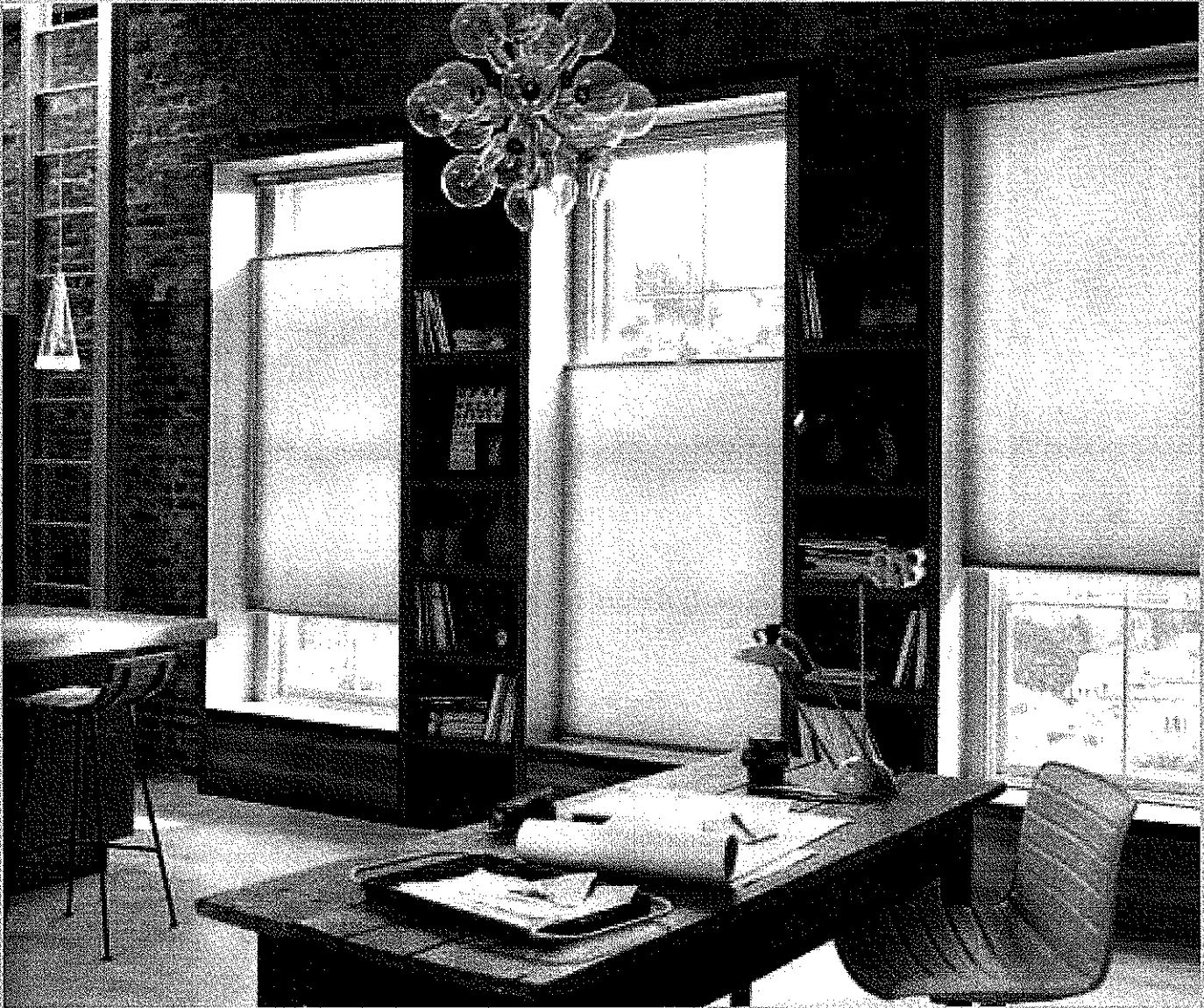

The durable, energy-efficient design of our Duette® FR Honeycomb Shades meets the new industry standard for superior functionality, ideal for healthcare and assisted living centers, government/military buildings and a wide variety of public spaces. Duette® FR Shades provide exceptional light control, structural frame sturdiness and significant insulating and acoustical properties.

SUSTAINABLE CONSTRUCTION

Certified to the standards of the GREENGUARD Environmental Institute, Duette® FR Shades meet the requirements of GREENGUARD Certified for Low VOC.

ENERGY EFFICIENT

The honeycomb structure provides R-value and shading capabilities and the reflective inner surface pockets reduce heat gain during the summer and reduce heat loss during the winter, helping you

INNOVATIVE DURABILITY

Durable headrail construction is designed to accommodate shade widths to 174" and shade heights to 72".

FABRIC COVERED HEADRAIL

Standard with LiteFlex® fabric pleated systems.

LIFETIME GUARANTEE

Operating Systems

Standard Cordlock
Standard cordlock operation

EasyRise™
This continuous cord loop and switch assembly makes operating large shades easy.

LiteRise®
A cordless system with a proprietary design allows you to raise and lower shades with the touch of a finger. No lift cords for a clean, uncluttered look and enhanced safety. Available in ¾" only.

Top-Down/Bottom-Up
A cordless system with a proprietary design allows you to raise and lower shades with the touch of a finger. No lift cords for a clean, uncluttered look and enhanced safety. Available in ¾" only.

Motorization
Available in all sizes and colors. Includes remote control and battery pack.

Specialty Shapes
Options include: arches, angles, trapezoids, circles, hexagons, octagons, and skylights.

Shade sizes vary based on fabric selection and hardware system. See Specifications section in the binder, or visit our website for a complete list of product specifications.

FR Fabrics

- Fabrics**
- Available in two soft, seamless, non-woven polyester fabrics
 - Fabrics meet or exceed all requirements of NFPA 701 small scale flammability testing for commercial applications
 - Block 99% of UV light rays to prevent fading
 - Fabrics are neutral to the exterior, ensuring a consistent appearance from the outside

- Opaque**
- ¾" pleat
 - Winter R-value = 5.74*
 - Solar shading coefficient = 0.25

- Semi-Opaque**
- ¾" and ¾" pleat sizes
 - ¾" Winter R-value = 5.16
 - ¾" Solar shading coefficient = 0.36
 - ¾" Winter R-value = 5.63
 - ¾" Solar shading coefficient = 0.31

* R-value includes the 3.5 R-value added by a standard low-e double glazed window.

Additional Options

Inside mount / outside mount or end mount, spacer blocks, extension brackets, swivel brackets (inside mount only), end mount brackets, hold-down brackets, cut-outs (surcharge), cord length.

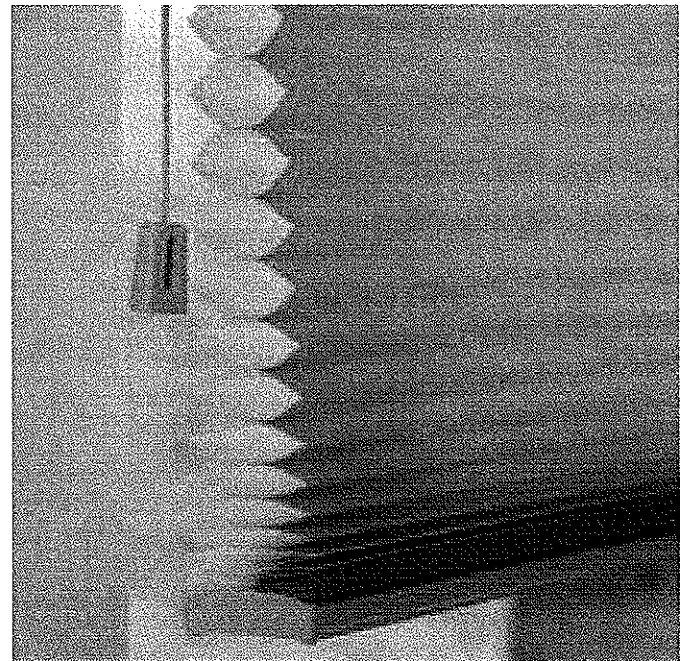

Duette® FR Honeycomb Shades

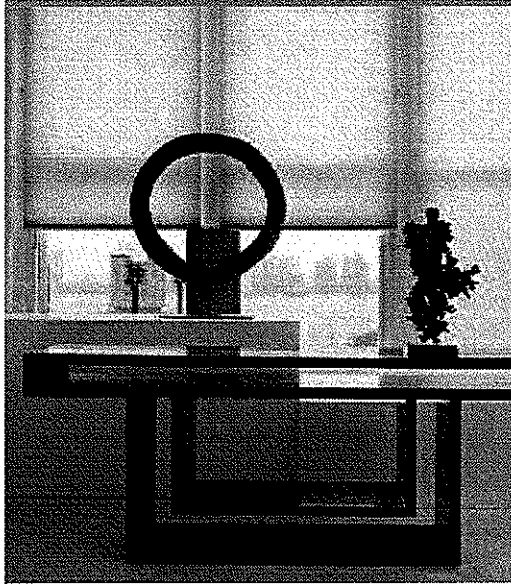

The durable, energy-efficient design of Duette® FR Honeycomb Shades makes them an ideal choice for healthcare and assisted living centers, government/military buildings, and a wide range of public spaces.

KEY FEATURES

- GREENGUARD Indoor Air Quality Certified® and GREENGUARD Children and Schools® certified for low-emitting products.
- Fabrics meet all requirements of NFPA 701 Small scale flammability testing for commercial applications.
- Energy-efficient honeycomb design.
- Fabric covered headrail standard with LiteRise™ and EasyRise™.
- Motorization available.
- Lifetime Guarantee.



Fabrics: 3/4" Semi-Opaque (D20), 3/4" Opaque (D16) and 3/8" Semi-Opaque (D21)



951 Daisy White

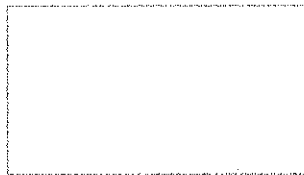

949 White Iris

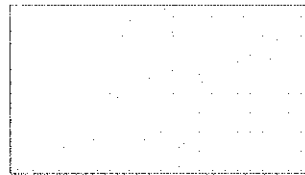

953 Linen

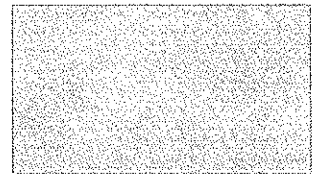

907 Beach Shells

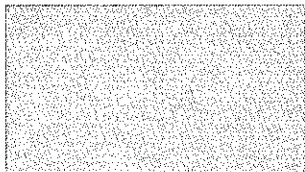

989 Bisque

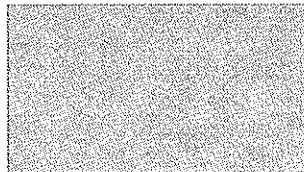

931 Flowering Cactus

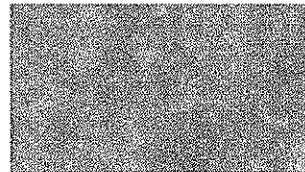

927 Moss Green

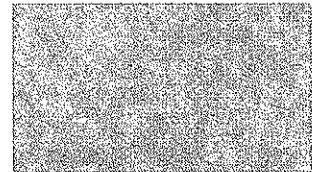

447 Colonial Blue



C O N S S 0 9 D U E T

HunterDouglasContract

WINDOW COVERINGS

© Copyright Hunter Douglas Contract 2009

® Hunter Douglas and its product names are registered trademarks.

® The GREENGUARD INDOOR AIR QUALITY CERTIFIED mark is a registered certification mark used under license through the GREENGUARD Environmental Institute.

LightBloc FlexShade

For total darkness, specify LIGHTBLOC FLEXSHADES. Ideal for audiovisual, conference and training rooms. Precision engineered and custom built for each opening. LIGHTBLOC FLEXSHADES may be motorized or manually operated with bead chain clutch, crank or spring roller.

Choose from any of our opaque fabrics (refer to pages 23-24 for colors). When SUNBLOC SB9000 or SB9100 fabric is specified, our exclusive, patented FABRIC RETENTION SYSTEM prevents disengagement of fabric from the channels.

Durable anodized and painted finishes ensure an aesthetically pleasing installation. All hardware is available with black, white, ivory, clear anodized or charcoal bronze finish.

System includes aluminum headbox, side and sill channels. No light gap at the headbox/side channel connection. Headboxes available to recess or surface mount (standard). Internal light seals and opacity plates eliminate all light leaks. Light proof hem bar recessed into light proof side channel. To ensure total blackout, caulking around perimeter is recommended. U.S. Patent No. 5,323,831.

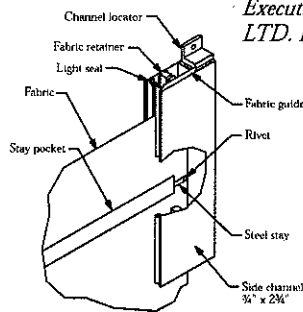

Inside mounting of LightBloc requires mounting angle, not shown.

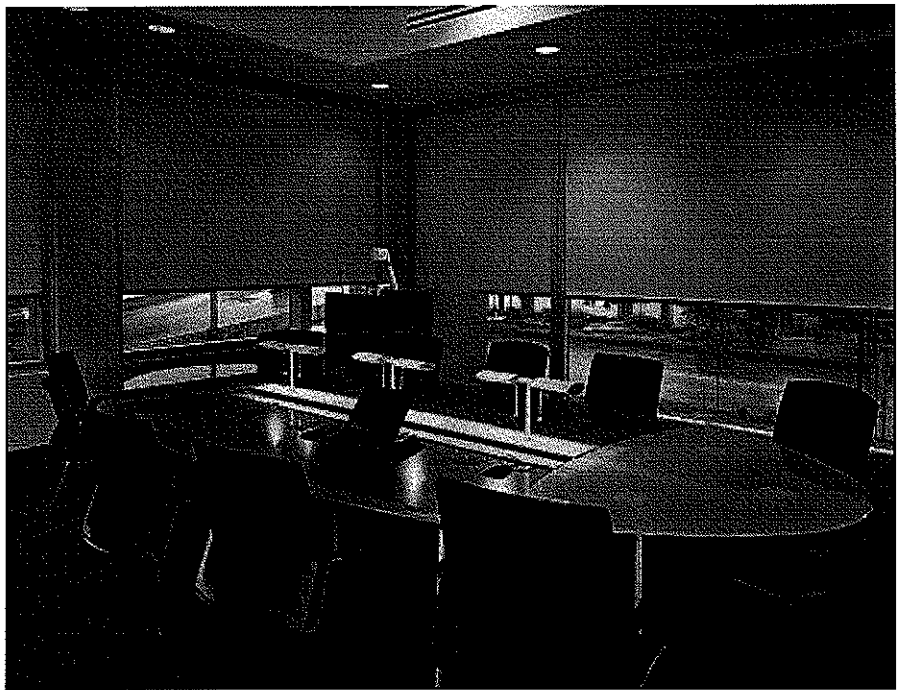

LightBloc FlexShades installed at Little Rock (AR) Regional Chamber of Commerce, Executive Video Teleconference Room. Specified by Polk Stanley Yeary Architects, LTD. Photography by Timothy Hursley, Little Rock, AR.

Fabrics

Fabric selection is illustrated on pp. 18-24.

- Flocké
- 1260 & 1309
- Nocturne II
- Roc-rol™
- SunBloc Series SB9000/9100

Operating Systems

Motorized Operation—for maximum reliability and convenience. Motor is located within the right or left end of the roller for smooth, reliable operation. A wide variety of control options are available; refer to page 12.

Crank Operator—offers complete reliability and precise light control, with virtually no effort. Even the largest shades operate smoothly. Compact bi-directional gear assembly can be mounted either right or left, as preferred. Crank hinges to form a thin, straight rod at edge of window when not in use. Crank operator can be permanently mounted or detached.

Bead Chain Clutch—Unlike competitive clutches, the DRAPER bi-directional clutch never needs adjusting and can be mounted either right or left. Shades stop when operating chain is released. Standard metal bead chain hangs at the side, leaving the view unobstructed. The optional chain hold-down is designed to keep children from getting tangled in the cord. Preset up and down stops prevent shades from being raised or lowered too far. DRAPER'S unique LIGHT SEAL KIT prevents light from coming through where the chain exits the headbox.

Spring Roller—Galvanized steel rollers and heavy-duty springs sized to operate safely and reliably. Roller is under constant tension, with a latching chain at sill (see detail at right).

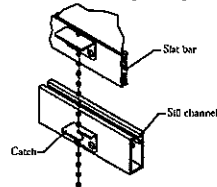

Dimensional Drawings—LightBloc System

Available in sizes through 8' wide x 10' high. Cannot be coupled. See page 14 for component details.

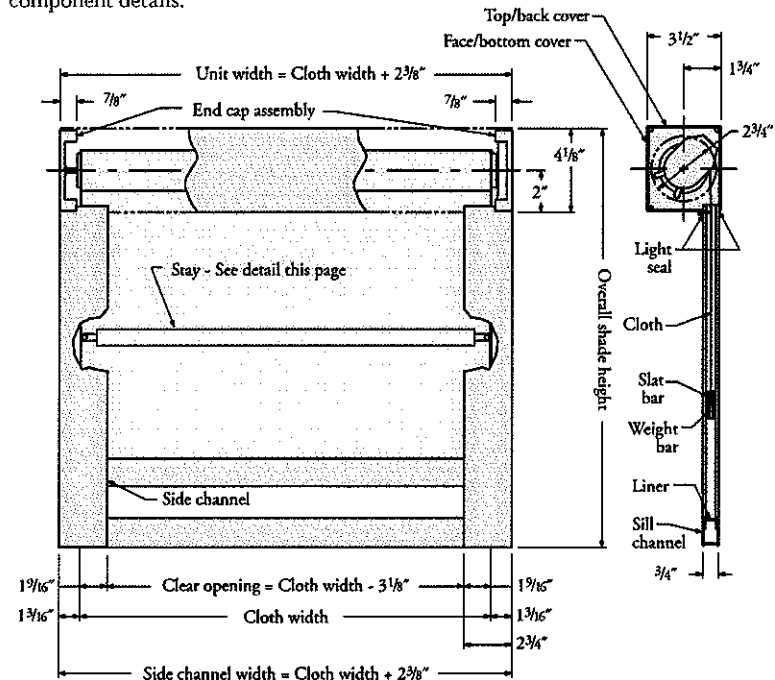

Note: For proper operation, LightBloc units must be installed square and plumb. Installers must be qualified craftsmen.



State of West Virginia
 Department of Administration
 Purchasing Division
 2019 Washington Street East
 Post Office Box 50130
 Charleston, WV 25305-0130

Request for Quotation

RFQ NUMBER
DNR210242

PAGE
1

ADDRESS CORRESPONDENCE TO ATTENTION OF
FRANK WHITTAKER 804-558-2316

VENDOR	RFQ COPY
	TYPE NAME/ADDRESS HERE

SHIP TO	DIVISION OF NATURAL RESOURCES
	TWIN FALLS RESORT
	ATTN: PARK SUPERINTENDENT
	RT. 97, PO BOX 667
	MULLENS, WV 25882 304-294-6000

DATE PRINTED	TERMS OF SALE	SHIP VIA	F.O.B.	FREIGHT TERMS
08/16/2010				

BID OPENING DATE: 08/25/2010 BID OPENING TIME 01:30PM

LINE	QUANTITY	UOP	CAT NO.	ITEM NUMBER	UNIT PRICE	AMOUNT
***** ADDENDUM NO. 1 *****						
THIS ADDENDUM IS ISSUED TO PROVIDE THE ATTACHED TECHNICAL QUESTIONS AND ANSWERS.						
BID OPENING DATE AND TIME HAVE NOT CHANGED.						
***** END ADDENDUM NO. 2 *****						
0001	1	LS		870-90	No Change needed to	original bid
						WINDOW BLINDS
***** THIS IS THE END OF RFQ DNR210242 ***** TOTAL:						No change

RECEIVED

2010 AUG 24 A 10:10

PURCHASING DIVISION
STATE OF WV

Allison Calca

Digitally signed by Allison Calca
 DN: cn=Allison Calca, o=Thomas W. Raftery, Inc. ou=Sales

SIGNATURE	Date: 2010.08.23 09:08:57 -0400'	TELEPHONE	DATE
TITLE	FEIN	1-800-243-2887 x 302	8/23/10
Sales & Marketing	060813877	ADDRESS CHANGES TO BE NOTED ABOVE	

WHEN RESPONDING TO RFQ, INSERT NAME AND ADDRESS IN SPACE ABOVE LABELED 'VENDOR'

DNR210242
Twin Falls Resort State Park
Window Blinds Purchase and Installation
ADDENDUM NUMBER ONE

Question/ Comment:

The only available FR cell shade on the market at this time is a Hunter Douglas commercial cell shade.

Answer:

FR application of commercial grade cell shades will be accepted provided, that certification falls under the California Small Scale, NFPA 701 standards, and that certification will be provided at the completion of FR application.

Question/ Comment:

It is not available in a $\frac{3}{8}$ " inch blackout & cordless model, only $\frac{3}{4}$ ".

Answer:

Per General Window Shade Specifications: #3, Minimum $\frac{3}{8}$ " / Maximum $\frac{3}{4}$ " single cell shades for windows. Per General Window Shade Specifications: Item #4 – a shade larger than $\frac{3}{8}$ " will be accepted, but it cannot exceed $\frac{3}{4}$ " so that it can clear the door hardware.

Question/ Comment:

Do you currently have cellular blinds in your facility? If you do, what brand do you have?

Answer:

Twin Falls does not currently have cellular blinds at any of its facilities.

DNR210242
Twin Falls Resort State Park
Window Blinds Purchase and Installation
ADDENDUM NUMBER ONE

Question/ Comment:

Can you provide me with a definition of side channels? In our business we refer to side channels when dealing with sky lights.

Answer:

These are light blocking side channels for the windows in the conference rooms.

Question/ Comment:

I would like to know the color scheme in all areas that will be furnished with blinds.

Answer:

Color scheme is to be determined based upon available fabric selections from successful furniture vendor.

Question/ Comment:

Are there other blind options that would be considered other than cellular?

Answer:

No, cellular blinds are the preferred window treatment that will work successfully and blend architecturally with the new construction.

VENDOR PREFERENCE CERTIFICATE

Certification and application* is hereby made for Preference in accordance with West Virginia Code, §5A-3-37. (Does not apply to construction contracts). West Virginia Code, §5A-3-37, provides an opportunity for qualifying vendors to request (at the time of bid) preference for their residency status. Such preference is an evaluation method only and will be applied only to the cost bid in accordance with the West Virginia Code. This certificate for application is to be used to request such preference. The Purchasing Division will make the determination of the Resident Vendor Preference, if applicable.

- 1. Application is made for 2.5% resident vendor preference for the reason checked: Bidder is an individual resident vendor and has resided continuously in West Virginia for four (4) years immediately preceding the date of this certification; or, Bidder is a partnership, association or corporation resident vendor and has maintained its headquarters or principal place of business continuously in West Virginia for four (4) years immediately preceding the date of this certification; or 80% of the ownership interest of Bidder is held by another individual, partnership, association or corporation resident vendor who has maintained its headquarters or principal place of business continuously in West Virginia for four (4) years immediately preceding the date of this certification; or, Bidder is a nonresident vendor which has an affiliate or subsidiary which employs a minimum of one hundred state residents and which has maintained its headquarters or principal place of business within West Virginia continuously for the four (4) years immediately preceding the date of this certification; or,
2. Application is made for 2.5% resident vendor preference for the reason checked: Bidder is a resident vendor who certifies that, during the life of the contract, on average at least 75% of the employees working on the project being bid are residents of West Virginia who have resided in the state continuously for the two years immediately preceding submission of this bid; or,
3. Application is made for 2.5% resident vendor preference for the reason checked: Bidder is a nonresident vendor employing a minimum of one hundred state residents or is a nonresident vendor with an affiliate or subsidiary which maintains its headquarters or principal place of business within West Virginia employing a minimum of one hundred state residents who certifies that, during the life of the contract, on average at least 75% of the employees or Bidder's affiliate's or subsidiary's employees are residents of West Virginia who have resided in the state continuously for the two years immediately preceding submission of this bid; or,
4. Application is made for 5% resident vendor preference for the reason checked: Bidder meets either the requirement of both subdivisions (1) and (2) or subdivision (1) and (3) as stated above; or,
5. Application is made for 3.5% resident vendor preference who is a veteran for the reason checked: Bidder is an individual resident vendor who is a veteran of the United States armed forces, the reserves or the National Guard and has resided in West Virginia continuously for the four years immediately preceding the date on which the bid is submitted; or,
6. Application is made for 3.5% resident vendor preference who is a veteran for the reason checked: Bidder is a resident vendor who is a veteran of the United States armed forces, the reserves or the National Guard, if, for purposes of producing or distributing the commodities or completing the project which is the subject of the vendor's bid and continuously over the entire term of the project, on average at least seventy-five percent of the vendor's employees are residents of West Virginia who have resided in the state continuously for the two immediately preceding years.

Bidder understands if the Secretary of Revenue determines that a Bidder receiving preference has failed to continue to meet the requirements for such preference, the Secretary may order the Director of Purchasing to: (a) reject the bid; or (b) assess a penalty against such Bidder in an amount not to exceed 5% of the bid amount and that such penalty will be paid to the contracting agency or deducted from any unpaid balance on the contract or purchase order.

By submission of this certificate, Bidder agrees to disclose any reasonably requested information to the Purchasing Division and authorizes the Department of Revenue to disclose to the Director of Purchasing appropriate information verifying that Bidder has paid the required business taxes, provided that such information does not contain the amounts of taxes paid nor any other information deemed by the Tax Commissioner to be confidential.

Under penalty of law for false swearing (West Virginia Code, §61-5-3), Bidder hereby certifies that this certificate is true and accurate in all respects; and that if a contract is issued to Bidder and if anything contained within this certificate changes during the term of the contract, Bidder will notify the Purchasing Division in writing immediately.

Bidder: Thomas W. Raftery, Inc.

Signed: [Signature]

Date: 7/27/10

Title: Sales & Marketing

*Check any combination of preference consideration(s) indicated above, which you are entitled to receive.

STATE OF WEST VIRGINIA
Purchasing Division

PURCHASING AFFIDAVIT

West Virginia Code §5A-3-10a states: No contract or renewal of any contract may be awarded by the state or any of its political subdivisions to any vendor or prospective vendor when the vendor or prospective vendor or a related party to the vendor or prospective vendor is a debtor and the debt owed is an amount greater than one thousand dollars in the aggregate.

DEFINITIONS:

"Debt" means any assessment, premium, penalty, fine, tax or other amount of money owed to the state or any of its political subdivisions because of a judgment, fine, permit violation, license assessment, defaulted workers' compensation premium, penalty or other assessment presently delinquent or due and required to be paid to the state or any of its political subdivisions, including any interest or additional penalties accrued thereon.

"Debtor" means any individual, corporation, partnership, association, limited liability company or any other form or business association owing a debt to the state or any of its political subdivisions. "Political subdivision" means any county commission; municipality; county board of education; any instrumentality established by a county or municipality; any separate corporation or instrumentality established by one or more counties or municipalities, as permitted by law; or any public body charged by law with the performance of a government function or whose jurisdiction is coextensive with one or more counties or municipalities. "Related party" means a party, whether an individual, corporation, partnership, association, limited liability company or any other form or business association or other entity whatsoever, related to any vendor by blood, marriage, ownership or contract through which the party has a relationship of ownership or other interest with the vendor so that the party will actually or by effect receive or control a portion of the benefit, profit or other consideration from performance of a vendor contract with the party receiving an amount that meets or exceeds five percent of the total contract amount.

EXCEPTION: The prohibition of this section does not apply where a vendor has contested any tax administered pursuant to chapter eleven of this code, workers' compensation premium, permit fee or environmental fee or assessment and the matter has not become final or where the vendor has entered into a payment plan or agreement and the vendor is not in default of any of the provisions of such plan or agreement.

Under penalty of law for false swearing (*West Virginia Code §61-5-3*), it is hereby certified that the vendor affirms and acknowledges the information in this affidavit and is in compliance with the requirements as stated.

WITNESS THE FOLLOWING SIGNATURE

Vendor's Name: Thomas W. Raftery, Inc.

Authorized Signature: *Thomas W. Raftery* Date: 7/27/10

State of Connecticut

County of Hartford, to-wit:

Taken, subscribed, and sworn to before me this 27th day of July, 2010

My Commission expires May 31, 2010

AFFIX SEAL HERE

NOTARY PUBLIC Irena Dos Santos

Irena Dos Santos
Notary Public
State of Connecticut
No. 109128
My Commission Expires:
May 31, 2015

