



State of West Virginia
 Department of Administration
 Purchasing Division
 2019 Washington Street East
 Post Office Box 50130
 Charleston, WV 25305-0130

Request for Quotation

RFQ NUMBER
DMV110150

PAGE
1

ADDRESS CORRESPONDENCE TO ATTENTION OF
FRANK WHITTAKER 304-558-2316

RFQ COPY
 TYPE NAME/ADDRESS HERE

Lee Hartman & Sons, Inc.
 3 Davis Court
 Hurricane WV 25526

DIVISION OF MOTOR VEHICLES

1317 HANSFORD STREET
 CHARLESTON, WV
 25311 558-0002

DATE PRINTED	TERMS OF SALE	SHIP VIA	F.O.B.	FREIGHT TERMS
03/29/2011	net 30	delivered	Dest	PPD

BID OPENING DATE: 05/10/2011 BID OPENING TIME 01:30PM

LINE	QUANTITY	UOP	CAT NO	ITEM NUMBER	UNIT PRICE	AMOUNT
0001	1	EA		840-99		87,629.75
<p>AUDIO, VIDEO, DATA PROJECTION EQUIPMENT & COMPONENTS</p> <p>THE WEST VIRGINIA PURCHASING DIVISION, FOR THE AGENCY, WEST VIRGINIA DIVISION OF MOTOR VEHICLES, IS SOLICITING BIDS FROM RESPONSIBLE VENDORS TO PROVIDE AND INSTALL AUDIO, VIDEO, DATA PROJECTION AND COMMUNICATIONS EQUIPMENT AT THE DMV SERVICE CENTER LOCATED AT 5707 MACCORKLE AVENUE S.E CHARLESTON, WV 25317, PER THE ATTACHED SPECIFICATIONS.</p> <p>MANDATORY PRE-BID</p> <p>A MANDATORY PRE-BID WILL BE HELD ON 4/19/11 @ 10:00 AM 5707 MCCORKLE AVE SE, CHARLESTON, WV 25317. ALL INTERESTED PARTIES ARE REQUIRED TO ATTEND THIS MEETING. FAILURE TO ATTEND THE MANDATORY PRE-BID SHALL RESULT IN DISQUALIFICATION OF THE BID. NO ONE PERSON MAY REPRESENT MORE THAN ONE BIDDER.</p> <p>AN ATTENDANCE SHEET WILL BE MADE AVAILABLE FOR ALL POTENTIAL BIDDERS TO COMPLETE. THIS WILL SERVE AS THE OFFICIAL DOCUMENT VERIFYING ATTENDANCE AT THE MANDATORY PRE-BID. FAILURE TO PROVIDE YOUR COMPANY AND REPRESENTATIVE NAME ON THE ATTENDANCE SHEET WILL RESULT IN DISQUALIFICATION OF THE BID. THE STATE WILL NOT ACCEPT ANY OTHER DOCUMENTATION TO VERIFY ATTENDANCE. THE BIDDER IS RESPONSIBLE FOR ENSURING THEY HAVE COMPLETED THE INFORMATION REQUIRED ON THE ATTENDANCE SHEET. THE PURCHASING DIVISION AND THE STATE AGENCY WILL NOT ASSUME ANY RESPONSIBILITY FOR A BIDDER-S</p>						

RECEIVED
 2011 MAY 18 AM 9:12
 WV PURCHASING
 DIVISION

SEE REVERSE SIDE FOR TERMS AND CONDITIONS			
SIGNATURE <i>Larry B. Cox</i>	TELEPHONE 304-397-4100	DATE 05-17-2011	
TITLE Area Manager	FEIN 540716361	ADDRESS CHANGES TO BE NOTED ABOVE	

WHEN RESPONDING TO RFQ, INSERT NAME AND ADDRESS IN SPACE ABOVE LABELED 'VENDOR'



State of West Virginia
 Department of Administration
 Purchasing Division
 2019 Washington Street East
 Post Office Box 50130
 Charleston, WV 25305-0130

Request for Quotation

RFQ NUMBER
DMV110150

PAGE
2

ADDRESS CORRESPONDENCE TO ATTENTION OF
FRANK WHITTAKER
304-558-2316

VENDOR

RFQ COPY
 TYPE NAME/ADDRESS HERE

Lee Hartman & Sons, Inc.
 3 Davis Court
 Hurricane WV 25526

SHIP TO

DIVISION OF MOTOR VEHICLES

1317 HANSFORD STREET
 CHARLESTON, WV
 25311 558-0002

DATE PRINTED	TERMS OF SALE	SHIP VIA	F.O.B.	FREIGHT TERMS
03/29/2011	net 30	delivered	Dest	PPD

BID OPENING DATE: 05/10/2011 BID OPENING TIME 01:30PM

LINE	QUANTITY	UOP	CAT NO.	ITEM NUMBER	UNIT PRICE	AMOUNT
<p>FAILURE TO COMPLETE THE PRE-BID ATTENDANCE SHEET. IN ADDITION, WE REQUEST THAT ALL POTENTIAL BIDDERS INCLUDE THEIR E-MAIL ADDRESS AND FAX NUMBER.</p> <p>ALL POTENTIAL BIDDERS ARE REQUESTED TO ARRIVE PRIOR TO THE STARTING TIME FOR THE PRE-BID. BIDDERS WHO ARRIVE LATE, BUT PRIOR TO THE DISMISSAL OF THE TECHNICAL PORTION OF THE PRE-BID WILL BE PERMITTED TO SIGN IN. BIDDERS WHO ARRIVE AFTER CONCLUSION OF THE TECHNICAL PORTION OF THE PRE-BID, BUT DURING ANY SUBSEQUENT PART OF THE PRE-BID WILL NOT BE PERMITTED TO SIGN THE ATTENDANCE SHEET.</p> <p>ALL TECHNICAL QUESTIONS MUST BE SUBMITTED IN WRITING TO FRANK WHITTAKER IN THE WV PURCHASING DIVISION VIA EMAIL @ FRANK.M.WHITTAKER@WV.GOV OR VIA FAX @ 304-558-4115. DEADLINE FOR ALL TECHNICAL QUESTIONS IS 4/22/11 @ 4:00 PM. ALL TECHNICAL QUESTIONS WILL BE ADDRESSED BY ADDENDUM AFTER THE DEADLINE.</p> <p>EXHIBIT 5</p> <p>WEST VIRGINIA CODE 21-1D-5 PROVIDES THAT: ANY SOLICITATION FOR A PUBLIC IMPROVEMENT CONSTRUCTION CONTRACT REQUIRES EACH VENDOR THAT SUBMITS A BID FOR THE WORK TO SUBMIT AT THE SAME TIME AN AFFIDAVIT OF COMPLIANCE WITH THE BID. THE ENCLOSED DRUG-FREE WORKPLACE AFFIDAVIT MUST BE SIGNED AND SUBMITTED WITH THE BID AS EVIDENCE OF THE VENDOR'S COMPLIANCE WITH THE PROVISIONS OF ARTICLE 1D, CHAPTER 21 OF THE WEST VIRGINIA CODE. FAILURE TO SUBMIT THE SIGNED DRUG-FREE WORKPLACE AFFIDAVIT WITH THE BID SHALL RESULT IN DISQUALIFICATION OF SUCH BID.</p> <p>NOTICE TO PROCEED: THIS CONTRACT IS TO BE PERFORMED WITHIN 60 CALENDAR DAYS AFTER THE NOTICE TO PROCEED</p>						

SEE REVERSE SIDE FOR TERMS AND CONDITIONS

SIGNATURE <i>Larry T. Cox</i>	TELEPHONE 304-397-4100	DATE 05-17-2011
TITLE Area Manager	FEIN 540716361	ADDRESS CHANGES TO BE NOTED ABOVE

WHEN RESPONDING TO RFQ, INSERT NAME AND ADDRESS IN SPACE ABOVE LABELED 'VENDOR'



State of West Virginia
 Department of Administration
 Purchasing Division
 2019 Washington Street East
 Post Office Box 50130
 Charleston, WV 25305-0130

Request for Quotation

RFQ NUMBER
DMV110150

PAGE
3

ADDRESS CORRESPONDENCE TO ATTENTION OF
FRANK WHITTAKER 304-558-2316

RFQ COPY
 TYPE NAME/ADDRESS HERE

Lee Hartman & Sons, Inc.
 3 Davis Court
 Hurricane WV 25526

DIVISION OF MOTOR VEHICLES

1317 HANSFORD STREET
 CHARLESTON, WV
 25311 558-0002

DATE PRINTED	TERMS OF SALE	SHIP VIA	F.O.B.	FREIGHT TERMS
03/29/2011	net 30	delivered	Dest	PPD

BID OPENING DATE: 05/10/2011 BID OPENING TIME 01:30PM

LINE	QUANTITY	UOP	CAT. NO.	ITEM NUMBER	UNIT PRICE	AMOUNT
<p>IS RECEIVED. UNLESS OTHERWISE SPECIFIED, THE FULLY EXECUTED PURCHASE ORDER WILL BE CONSIDERED NOTICE TO PROCEED.</p> <p>CANCELLATION: THE DIRECTOR OF PURCHASING RESERVES THE RIGHT TO CANCEL THIS CONTRACT IMMEDIATELY UPON WRITTEN NOTICE TO THE VENDOR IF THE MATERIALS OR WORKMANSHIP SUPPLIED ARE OF AN INFERIOR QUALITY OR DO NOT CONFORM WITH THE SPECIFICATIONS OF THE BID AND CONTRACT HERE IN.</p> <p>WAGE RATES: THE CONTRACTOR OR SUBCONTRACTOR SHALL PAY THE HIGHER OF THE U.S. DEPARTMENT OF LABOR MINIMUM WAGE RATES AS ESTABLISHED FOR KANAWHA COUNTY, PURSUANT TO WEST VIRGINIA CODE 21-5A, ET, SEQ. (PREVAILING WAGE RATES APPLY TO THIS PROJECT)</p> <p>ARBITRATION: ANY REFERENCES MADE TO ARBITRATION OR INTEREST FOR PAYMENTS DUE (EXCEPT FOR ANY INTEREST REQUIRED BY STATE LAW) CONTAINED IN THIS CONTRACT OR IN ANY AMERICAN INSTITUTE OF ARCHITECTS DOCUMENTS PERTAINING TO THIS CONTRACT ARE HEREBY DELETED.</p> <p>WORKERS' COMPENSATION: VENDOR IS REQUIRED TO PROVIDE A CERTIFICATE FROM WORKERS' COMPENSATION IF SUCCESSFUL.</p> <p>ALL OF THE ITEMS CHECKED BELOW WILL BE A REQUIREMENT OF THIS CONTRACT:</p> <p>(XX) INSURANCE: SUCCESSFUL VENDOR SHALL FURNISH PROOF OF COMMERCIAL GENERAL LIABILITY INSURANCE PRIOR TO ISSUANCE OF CONTRACT. UNLESS OTHERWISE SPECIFIED IN THE BID DOCUMENTS, THE MINIMUM AMOUNT OF INSURANCE COVERAGE REQUIRED IS \$250,000.</p> <p>() BUILDERS RISK INSURANCE: SUCCESSFUL VENDOR SHALL</p>						

SEE REVERSE SIDE FOR TERMS AND CONDITIONS

SIGNATURE: <i>Darryl N. Cox</i>	TELEPHONE: 304-397-4100	DATE: 05-17-2011
TITLE: Area Manager	FEIN: 540716361	ADDRESS CHANGES TO BE NOTED ABOVE

WHEN RESPONDING TO RFQ, INSERT NAME AND ADDRESS IN SPACE ABOVE LABELED 'VENDOR'



State of West Virginia
 Department of Administration
 Purchasing Division
 2019 Washington Street East
 Post Office Box 50130
 Charleston, WV 25305-0130

Request for Quotation

RFQ NUMBER
DMV110150

PAGE
4

ADDRESS CORRESPONDENCE TO ATTENTION OF
FRANK WHITTAKER
304-558-2316

RFQ COPY
TYPE NAME/ADDRESS HERE

Lee Hartman & Sons, Inc.
 3 Davis Court
 Hurricane WV 25526

DIVISION OF MOTOR VEHICLES

1317 HANSFORD STREET
CHARLESTON, WV
25311 558-0002

DATE PRINTED	TERMS OF SALE	SHIP VIA	F.O.B.	FREIGHT TERMS
03/29/2011	net 30	delivered	Dest	PPD

BID OPENING DATE: **05/10/2011** BID OPENING TIME **01:30PM**

LINE	QUANTITY	UOP	CAT NO.	ITEM NUMBER	UNIT PRICE	AMOUNT
<p>FURNISH PROOF OF BUILDERS RISK - ALL RISK INSURANCE IN AN AMOUNT EQUAL TO 100% OF THE AMOUNT OF THE CONTRACT.</p> <p>(XX) BONDS: FIVE PERCENT (5%) OF THE TOTAL AMOUNT OF THE BID PAYABLE TO THE STATE OF WEST VIRGINIA, SHALL BE SUBMITTED WITH EACH BID AS A BID BOND. THE SUCCESSFUL BIDDER SHALL ALSO FURNISH A PERFORMANCE BOND AND LABOR/MATERIAL BOND FOR 100% OF THE AMOUNT OF THE CONTRACT. BONDS MAY BE PROVIDED IN THE FORM OF A CERTIFIED CHECK, IRREVOCABLE LETTER OF CREDIT, OR BOND FURNISHED BY A SOLVENT SURETY COMPANY AUTHORIZED TO DO BUSINESS IN THE STATE OF WEST VIRGINIA. A LETTER OF CREDIT SUBMITTED IN LIEU OF A BOND WILL ONLY BE ALLOWED FOR PROJECTS UNDER \$100,000. PERSONAL OR BUSINESS CHECKS ARE NOT ACCEPTABLE IN LIEU OF THE 5% BID BOND, PERFORMANCE BOND, OR LABOR AND MATERIAL BOND.</p> <p>() MAINTENANCE BOND: A TWO (2) YEAR MAINTENANCE BON COVERING THE ROOFING SYSTEM WILL BE A REQUIREMENT OF THE SUCCESSFUL VENDOR.</p> <p>REV. 11/00</p> <p>EXHIBIT 7</p> <p>DOMESTIC ALUMINUM, GLASS & STEEL IN PUBLIC WORKS PROJECTS</p> <p>IN ACCORDANCE WITH WEST VIRGINIA CODE 5-19-1 ET., SEQ., EVERY CONTRACT FOR CONSTRUCTION, RECONSTRUCTION, ALTERATION, REPAIR, IMPROVEMENT OR MAINTENANCE OF PUBLIC WORKS, WHERE THE COST IS MORE THAN \$50,000 AND, IN THE CASE OF STEEL ONLY, WHERE THE COST OF STEEL IS MORE THAN \$50,000 OR WHERE MORE THAN 10,000 POUNDS OF STEEL ARE REQUIRED, THE STATE WILL ACCEPT ONLY ALUMINU</p>						

SEE REVERSE SIDE FOR TERMS AND CONDITIONS

SIGNATURE <i>Randy T. Cox</i>	TELEPHONE 304-397-5100	DATE 05-17-2011
TITLE Area Manager	FEIN 540716361	ADDRESS CHANGES TO BE NOTED ABOVE

WHEN RESPONDING TO RFQ, INSERT NAME AND ADDRESS IN SPACE ABOVE LABELED 'VENDOR'



State of West Virginia
 Department of Administration
 Purchasing Division
 2019 Washington Street East
 Post Office Box 50130
 Charleston, WV 25305-0130

Request for Quotation

RFQ NUMBER
DMV110150

PAGE
5

ADDRESS CORRESPONDENCE TO ATTENTION OF
FRANK WHITTAKER
304-558-2316

RFQ COPY
TYPE NAME/ADDRESS HERE

VENDOR

Lee Hartman & Sons, Inc.
 3 Davis Court
 Hurricane WV 25526

SHIP TO

DIVISION OF MOTOR VEHICLES

1317 HANSFORD STREET
CHARLESTON, WV
25311 558-0002

DATE PRINTED	TERMS OF SALE	SHIP VIA	F.O.B.	FREIGHT TERMS
03/29/2011	net 30	delivered	Dest	PPD

BID OPENING DATE: **05/10/2011** BID OPENING TIME **01:30PM**

LINE	QUANTITY	UOP	CAT. NO.	ITEM NUMBER	UNIT PRICE	AMOUNT
<p>GLASS, OR STEEL PRODUCTS PRODUCED IN THE UNITED STATES. IN ADDITION, ITEMS OF MACHINERY OR EQUIPMENT PURCHASED FOR USE AT THE SITE OF PUBLIC WORKS SHALL BE MADE OF DOMESTIC ALUMINUM, GLASS OR STEEL, UNLESS THE COST OF THE PRODUCT IS LESS THAN \$50,000 OR LESS THAN 10,000 POUNDS OF STEEL ARE USED IN PUBLIC WORKS PROJECTS.</p> <p>FOREIGN MADE ALUMINUM, GLASS OR STEEL PRODUCTS MAY BE ACCEPTED ONLY IF THE COST OF DOMESTIC PRODUCTS IS FOUND TO BE UNREASONABLE. SUCH COST IS UNREASONABLE IF IT IS 20% OR MORE HIGHER THAN THE BID PRICE FOR FOREIGN MADE PRODUCTS. IF THE DOMESTIC ALUMINUM, GLASS OR STEEL PRODUCTS TO BE SUPPLIED OR PRODUCED IN A "SUBSTANTIAL LABOR SURPLUS AREA", AS DEFINED BY THE UNITED STATES DEPARTMENT OF LABOR, FOREIGN PRODUCTS MAY BE SUPPLIED ONLY IF DOMESTIC PRODUCTS ARE 30% OR MORE HIGHER IN PRICE THAN THE FOREIGN MADE PRODUCTS.</p> <p>IF, PRIOR TO THE AWARD OF A CONTRACT UNDER THE ABOVE PROVISIONS, THE SPENDING OFFICER OF THE SPENDING UNIT DETERMINES THAT THERE EXISTS A BID FOR LIKE FOREIGN ALUMINUM, GLASS OR STEEL THAT IS REASONABLE AND LOWER THAN THE LOWEST BID DOMESTIC PRODUCTS, THE SPENDING OFFICE MAY REQUEST, IN WRITING, A REEVALUATION AND REDUCTION IN THE LOWEST BID FOR SUCH DOMESTIC PRODUCTS. ALL VENDORS MUST INDICATE IN THEIR BID IF THEY ARE SUPPLYING FOREIGN ALUMINUM, GLASS OR STEEL.</p> <p>REV. 3/88</p> <p>EXHIBIT 9</p> <p>NOTICE FOR ISSUANCE & ACKNOWLEDGEMENT OF CONSTRUCTION PROJECT ADDENDA</p>						

SEE REVERSE SIDE FOR TERMS AND CONDITIONS

SIGNATURE <i>Randy Cox</i>	TELEPHONE 304-397-4100	DATE 05-17-2011
TITLE Area Manager	FEIN 540716361	ADDRESS CHANGES TO BE NOTED ABOVE

WHEN RESPONDING TO RFQ, INSERT NAME AND ADDRESS IN SPACE ABOVE LABELED 'VENDOR'



State of West Virginia
 Department of Administration
 Purchasing Division
 2019 Washington Street East
 Post Office Box 50130
 Charleston, WV 25305-0130

Request for Quotation

RFQ NUMBER
DMV110150

PAGE
6

ADDRESS CORRESPONDENCE TO ATTENTION OF
FRANK WHITTAKER 304-558-2316

VENDOR

RFQ COPY
 TYPE NAME/ADDRESS HERE

Lee Hartman & Sons, Inc.
 3 Davis Court
 Hurricane WV 25526

SHIP TO

DIVISION OF MOTOR VEHICLES

1317 HANSFORD STREET
 CHARLESTON, WV
 25311 558-0002

DATE PRINTED	TERMS OF SALE	SHIP VIA	F.O.B.	FREIGHT TERMS
03/29/2011	net 30	delivered	Dest	PPD

BID OPENING DATE: 05/10/2011 BID OPENING TIME 01:30PM

LINE	QUANTITY	UOP	CAT NO.	ITEM NUMBER	UNIT PRICE	AMOUNT
<p>THE ARCHITECT/ENGINEER AND/OR AGENCY SHALL BE REQUIRED TO ABIDE BY THE FOLLOWING SCHEDULE IN ISSUING CONSTRUCTION PROJECT ADDENDA FOR STATE AGENCIES:</p> <p>(1) THE ARCHITECT/ENGINEER SHALL PREPARE THE ADDENDUM AND A LIST OF ALL PARTIES THAT HAVE PROCURED DRAWINGS AND SPECIFICATIONS FOR THE PROJECT. THE ADDENDUM AND LIST SHALL BE FORWARDED TO THE BUYER IN THE STATE PURCHASING DIVISION. THE ARCHITECT/ENGINEER SHALL ALSO SEND A COPY OF THE ADDENDUM TO THE STATE AGENCY FOR WHICH THE CONTRACT IS ISSUED.</p> <p>(2) THE BUYER SHALL SEND THE ADDENDUM TO ALL INTERESTED PARTIES AND, IF NECESSARY, EXTEND THE BID OPENING DATE. ANY ADDENDUM SHOULD BE RECEIVED BY THE BUYER WITHIN FOURTEEN (14) DAYS PRIOR TO THE BID OPENING DATE.</p> <p>(3) ALL ADDENDA SHOULD BE FORMALLY ACKNOWLEDGED BY ALL BIDDERS AND SUBMITTED TO THE STATE PURCHASING DIVISION. THE SAME RULES AND REGULATIONS THAT APPLY TO THE ORIGINAL BIDDING DOCUMENT SHALL ALSO APPLY TO AN ADDENDUM DOCUMENT. THE ONLY EXCEPTION MAY BE FOR AN ADDENDUM THAT IS ISSUED FOR THE SOLE PURPOSE OF CHANGING A BID OPENING TIME AND/OR DATE.</p> <p>REV. 11/96</p> <p>EXHIBIT 10</p> <p>ADDENDUM ACKNOWLEDGEMENT</p> <p>I HEREBY ACKNOWLEDGE RECEIPT OF THE FOLLOWING CHECKED ADDENDUM(S) AND HAVE MADE THE NECESSARY REVISIONS TO</p>						

SEE REVERSE SIDE FOR TERMS AND CONDITIONS

SIGNATURE <i>Darryl M. Cox</i>	TELEPHONE 304-397-4100	DATE 05-17-2011
TITLE Area Manager	FEIN 540716361	ADDRESS CHANGES TO BE NOTED ABOVE

WHEN RESPONDING TO RFQ, INSERT NAME AND ADDRESS IN SPACE ABOVE LABELED 'VENDOR'



State of West Virginia
 Department of Administration
 Purchasing Division
 2019 Washington Street East
 Post Office Box 50130
 Charleston, WV 25305-0130

Request for Quotation

RFQ NUMBER
DMV110150

PAGE
7

ADDRESS CORRESPONDENCE TO ATTENTION OF
**FRANK WHITTAKER
 304-558-2316**

RFQ COPY

TYPE NAME/ADDRESS HERE

Lee Hartman & Sons, Inc.
 3 Davis Court
 Hurricane WV 25526

SHIP TO

DIVISION OF MOTOR VEHICLES

1317 HANSFORD STREET
 CHARLESTON, WV
 25311 558-0002

DATE PRINTED	TERMS OF SALE	SHIP VIA	F.O.B.	FREIGHT TERMS
03/29/2011	net 30	delivered	Dest	PPD

BID OPENING DATE: **05/10/2011** BID OPENING TIME **01:30PM**

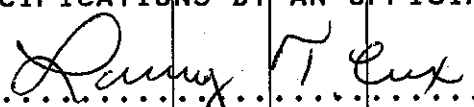
LINE	QUANTITY	UOP	CAT NO	ITEM NUMBER	UNIT PRICE	AMOUNT
MY PROPOSAL, PLANS AND/OR SPECIFICATION, ETC.						
ADDENDUM NOS.:						
NO. 1		✓	LC			
NO. 2		✓	LC			
NO. 3						
NO. 4						
NO. 5						
I UNDERSTAND THAT FAILURE TO CONFIRM THE RECEIPT OF THE ADDENDUM(S) MAY BE CAUSE FOR REJECTION OF THE BIDS.						
VENDOR MUST CLEARLY UNDERSTAND THAT ANY VERBAL REPRESENTATION MADE OR ASSUMED TO BE MADE DURING ANY ORAL DISCUSSION HELD BETWEEN VENDOR'S REPRESENTATIVES AND ANY STATE PERSONNEL IS NOT BINDING. ONLY THE INFORMATION ISSUED IN WRITING AND ADDED TO THE SPECIFICATIONS BY AN OFFICIAL ADDENDUM IS BINDING.						
SIGNATURE						
Lee Hartman & Sons, Inc.				COMPANY	
05-17-2011				DATE	
REV. 11/96						
CONTRACTORS LICENSE						

SEE REVERSE SIDE FOR TERMS AND CONDITIONS

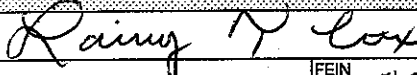
SIGNATURE 	TELEPHONE 304-397-4100	DATE 05-17-2011
TITLE Area Manager	FEIN 540716361	ADDRESS CHANGES TO BE NOTED ABOVE

WHEN RESPONDING TO RFQ, INSERT NAME AND ADDRESS IN SPACE ABOVE LABELED 'VENDOR'



State of West Virginia
 Department of Administration
 Purchasing Division
 2019 Washington Street East
 Post Office Box 50130
 Charleston, WV 25305-0130

Request for Quotation

RFQ NUMBER
DMV110150

PAGE
8

ADDRESS CORRESPONDENCE TO ATTENTION OF
FRANK WHITTAKER 304-558-2316

RFQ COPY
 TYPE NAME/ADDRESS HERE

Lee Hartman & Sons, Inc.
 3 Davis Court
 Hurricane WV 25526

DIVISION OF MOTOR VEHICLES

1317 HANSFORD STREET
 CHARLESTON, WV
 25311 558-0002

DATE PRINTED	TERMS OF SALE	SHIP VIA	F.O.B.	FREIGHT TERMS
03/29/2011	net 30	delivered	Dest	PPD

BID OPENING DATE: **05/10/2011** BID OPENING TIME: **01:30PM**

LINE	QUANTITY	UOP	CAT NO.	ITEM NUMBER	UNIT PRICE	AMOUNT
<p>WEST VIRGINIA STATE CODE 21-11-2 REQUIRES THAT ALL PERSONS DESIRING TO PERFORM CONTRACTING WORK IN THIS STATE MUST BE LICENSED. THE WEST VIRGINIA CONTRACTORS LICENSING BOARD IS EMPOWERED TO ISSUE THE CONTRACTORS LICENSE. APPLICATIONS FOR A CONTRACTORS LICENSE MAY BE MADE BY CONTACTING THE WEST VIRGINIA DIVISION OF LABOR CAPITOL COMPLEX, BUILDING 3, ROOM 319, CHARLESTON, WV 25305. TELEPHONE: (304) 558-7890.</p> <p>WEST VIRGINIA STATE CODE 21-11-11 REQUIRES ANY PROSPECTIVE BIDDER TO INCLUDE THE CONTRACTORS LICENSE NUMBER ON THEIR BID.</p> <p>BIDDER TO COMPLETE:</p> <p>CONTRACTORS NAME: Lee Hartman & Sons, Inc.</p> <p>CONTRACTORS LICENSE NO.: WV037465</p> <p>THE SUCCESSFUL BIDDER WILL BE REQUIRED TO FURNISH A COPY OF THEIR CONTRACTORS LICENSE PRIOR TO ISSUANCE OF A PURCHASE ORDER/CONTRACT</p> <p>APPLICABLE LAW</p> <p>THE WEST VIRGINIA STATE CODE, PURCHASING DIVISION RULES AND REGULATIONS, AND THE INFORMATION PROVIDED IN THE "REQUEST FOR QUOTATION" ISSUED BY THE PURCHASING DIVISION IS THE SOLE AUTHORITY GOVERNING THIS PROCUREMENT.</p> <p>ANY INFORMATION PROVIDED IN SPECIFICATION MANUALS, OR ANY OTHER SOURCE, VERBAL OR WRITTEN, WHICH CONTRADICTS OR ALTERS THE INFORMATION PROVIDED FROM THE SOURCES AS DESCRIBED IN THE ABOVE PARAGRAPH IS VOID AND OF NO EFFECT.</p>						

SEE REVERSE SIDE FOR TERMS AND CONDITIONS

SIGNATURE	<i>Randy Kelly</i>	TELEPHONE	304-397-4100	DATE	05-17-2011
TITLE	Area Manager	FEIN	540716361	ADDRESS CHANGES TO BE NOTED ABOVE	

WHEN RESPONDING TO RFQ, INSERT NAME AND ADDRESS IN SPACE ABOVE LABELED 'VENDOR'



State of West Virginia
 Department of Administration
 Purchasing Division
 2019 Washington Street East
 Post Office Box 50130
 Charleston, WV 25305-0130

Request for Quotation

RFQ NUMBER
DMV110150

PAGE
9

ADDRESS CORRESPONDENCE TO ATTENTION OF
FRANK WHITTAKER
304-558-2316

VENDOR

RFQ COPY
 TYPE NAME/ADDRESS HERE

Lee Hartman & Sons, Inc.
 3 Davis Court
 Hurricane WV 25526

SHIP TO

DIVISION OF MOTOR VEHICLES

1317 HANSFORD STREET
 CHARLESTON, WV
 25311 558-0002

DATE PRINTED	TERMS OF SALE	SHIP VIA	FOB	FREIGHT TERMS
03/29/2011	net 30	delivered	Dest	PPD

BID OPENING DATE: **05/10/2011** BID OPENING TIME **01:30PM**

LINE	QUANTITY	UOP	CAT NO	ITEM NUMBER	UNIT PRICE	AMOUNT
<p>BANKRUPTCY: IN THE EVENT THE VENDOR/CONTRACTOR FILES FOR BANKRUPTCY PROTECTION, THE STATE MAY DEEM THE CONTRACT NULL AND VOID, AND TERMINATE SUCH CONTRACT WITHOUT FURTHER ORDER.</p> <p>REV. 5/2009</p> <p style="text-align: center;">NOTICE</p> <p>A SIGNED BID MUST BE SUBMITTED TO:</p> <p style="text-align: center;">DEPARTMENT OF ADMINISTRATION PURCHASING DIVISION BUILDING 15 2019 WASHINGTON STREET, EAST CHARLESTON, WV 25305-0130</p> <p>THE BID SHOULD CONTAIN THIS INFORMATION ON THE FACE OF THE ENVELOPE OR THE BID MAY NOT BE CONSIDERED:</p> <p>SEALED BID</p> <p>BUYER: 44</p> <p>REQ. NO.: DMV110150</p> <p>BID OPENING DATE: 5/10/2011</p> <p>BID OPENING TIME: 1:30 PM</p> <p>PLEASE PROVIDE A FAX NUMBER IN CASE IT IS NECESSARY TO CONTACT YOU REGARDING YOUR BID:</p>						

SEE REVERSE SIDE FOR TERMS AND CONDITIONS

SIGNATURE	<i>Randy Lee</i>	TELEPHONE	304-397-4100	DATE	05-17-2011
TITLE	Area Manager	FEIN	540716361	ADDRESS CHANGES TO BE NOTED ABOVE	

WHEN RESPONDING TO RFQ, INSERT NAME AND ADDRESS IN SPACE ABOVE LABELED 'VENDOR'



State of West Virginia
 Department of Administration
 Purchasing Division
 2019 Washington Street East
 Post Office Box 50130
 Charleston, WV 25305-0130

Request for Quotation

RFQ NUMBER
DMV110150

PAGE
10

ADDRESS CORRESPONDENCE TO ATTENTION OF
**FRANK WHITTAKER
 304-558-2316**

VENDOR

**RFQ COPY
 TYPE NAME/ADDRESS HERE**

Lee Hartman & Sons, Inc.
 3 Davis Court
 Hurricane WV 25526

SHIP TO

DIVISION OF MOTOR VEHICLES

**1317 HANSFORD STREET
 CHARLESTON, WV
 25311 558-0002**

DATE PRINTED	TERMS OF SALE	SHIP VIA	F.O.B.	FREIGHT TERMS
03/29/2011	net 30	delivered	Dest	PPD

BID OPENING DATE: **05/10/2011** BID OPENING TIME **01:30PM**

LINE	QUANTITY	UOP	CAT NO	ITEM NUMBER	UNIT PRICE	AMOUNT
				304-397-4100		
PLEASE PRINT OR TYPE NAME OF PERSON TO CONTACT CONCERNING THIS QUOTE: LARRY COX						
***** THIS IS THE END OF RFQ DMV110150 ***** TOTAL:						

SEE REVERSE SIDE FOR TERMS AND CONDITIONS

SIGNATURE <i>Larry Cox</i>	TELEPHONE 304-397-4100	DATE 05-17-2011
TITLE Area Manager	FEIN 540716361	ADDRESS CHANGES TO BE NOTED ABOVE

WHEN RESPONDING TO RFQ, INSERT NAME AND ADDRESS IN SPACE ABOVE LABELED 'VENDOR'

DIVISION OF MOTOR VEHICLES
RFQ #

The West Virginia Division of Motor Vehicles (DMV) is requesting quotes for numerous audio, video, data projection and communications equipment components, to be installed at the Commissioner's Offices, located at 5705 MacCorkle Avenue, S.E., Charleston, West Virginia.

Attached is a list of AV equipment for two (2) conference/training rooms and one (1) ceiling-mounted projector for a common area. This equipment is being requested by the DMV's Commissioner, as part of the DMV's Modernization Project.

The DMV would like to have project initialization and completion done as quickly as possible, including procurement, installation and training.

GENERAL REQUIREMENTS

1. Vendors must attend a mandatory pre-bid walk-through of the facility on 04/19/2011 at 10:00 am at 5707 MacCorkle Avenue, Charleston, WV in the DMV Training Room.
2. Pricing shall include all labor and materials for proper installation of equipment.
3. Pricing shall include cost of Crestron (or equal) and related control code programming.
4. Pricing shall be all-inclusive of delivery, installation and system testing.
5. Bidder should provide with their bid a written schematic or plan for installation of the equipment.
6. Bidder shall provide a projected delivery, installation, system testing and training timeline to detail how the sixty (60) day installation requirement will be met.

7. Bidder shall maintain all manufacturers' certifications required for reseller installation, programming, warranty and maintenance support.
8. Access above ceiling and AC Power outlets to proscribed points shall be coordinated by the DMV.
9. This installation shall include all cable access and cable raceways and cable access to all equipment. The Vendor will be responsible for installing all vendor-provided hardware into the existing structure, and for providing the necessary electrical and cable connections. The vendor will provide a single point of contact to assist in readying the site for system installation. The vendor will then be responsible for mounting, installing and connecting all provided components, including complete testing of the equipment.
10. One day (eight hours) of training and documentation on operation and maintenance procedures shall be provided to four (4) designated staff personnel, upon completion of installation.

SPECIFICATIONS

The model/ brand/specifications named herein establish the acceptable level of quality only and are not intended to reflect a preference or favor any particular brand or vendor. The following specifications are to be considered minimum acceptable specifications unless otherwise noted in this document. It is preferred that the manufacturer specification sheets be provided with the bid, however specification sheets must be provided within 48 hours of request. Failure to provide the manufacturer specifications within 48 hours of request may result in bid disqualification.

Qty.	Item Description	Unit Cost	Extended Cos
3	<p><u>Sanvo PDG-DHT100L DPL Multimedia Projector</u> substitute Eiki EIP-HDT30 Resolution: HD 1920 x 1080 (UXGA dot resizing possible) Brightness: 6,500 ANSI lumens Pixels: (2,073,600) 1920 x 1080 (16:9) Scanning Frequency: Horizontal: 15-120KHz Vertical 48-120Hz Input Signal Compatibility: UXGA/SXGA+/SXGA/WXGA/XGA/SVGA/VGA/MAC 1080P-24/25/30/48/50/60, 1080psf-24/25/30 1080i-50/60, 720p-50/60/575p/480p/575i/480i Color System: PAL/SECAM/NTSC/NTSC4.43/PAL-M/N Image Size (diagonal): Minimum 50" -Maximum 600" Weight: 44 pounds max Dimensions: 16"(w) x10"(h) x21"(d) PC Input/Output: 2 Digital Video Input; DVI-D x 1 (1 HDCP compatible) Analog RGB input x 1; D-sub 15-pin x 1 BNC x 5 (RGBHV, VIDEO/Y-Pb/Cb-Pr/Cr) S-Video x 1 RJ45 LAN x1, Serial D-sub9IN x 1 One empty expansion slot Accessories: Color Reproduction Wheel Set High Brightness Color Wheel Set (Installed) Wireless Remote Removable Power Cord with Fixing Bracket D-Sub Computer Cable Instruction Manual and CD/DVD Three year warranty (parts and labor)</p>	11,300.00	33,900.00
3	<p><u>Sanvo LNS-T50 Long Zoom Lens</u></p> <ul style="list-style-type: none"> • 2.8 - 5.0:1 Throw Ratio • 59.3 - 106.7mm Focal Length • 1.8x Power Zoom <p style="text-align: right;">Eiki AH-43007T</p>	5,220.00	15,660.00

	• <i>f</i> 2.0 - 2.9		
3	<u>Sanyo 645 099 0199 Remote Control</u> (MUST BE COMPATIBLE WITH BOTH PROPOSED PROJECTOR AND LONG ZOOM LENS)	included	included
3	<u>Peerless CMJ455 Drop Ceiling Mount Adapter</u> (MUST MATCH THE CEILING MOUNT KIT DESCRIBED BELOW, IF PRESENTED AS "EQUAL TO.")	125.00	375.00
3	<u>Peerless PRGUNV Projector Ceiling Mount Kit</u> <ul style="list-style-type: none"> • Replaces a 2' x 2' (609 x 609 mm) ceiling tile; or mounts above existing 2' x 2' (609 x 609 mm) or 2' x 4' (609 x 1219 mm) ceiling tile to structural ceiling with tie wires • Two-piece design offering five different points for mount attachment • Includes tie wire supports, flush mount tube and offers two knockout panels for outlet boxes • Unit has 1-1/2"-11.5 NPT (38 mm) fitting for attachment of extension column • Load Capability: 50 lb (22 kg) 	58.25	174.75
2	<u>Dalite 88393L C (Cherry Veneer/Black End Caps)</u> Contour Electrol HDTV w/LVC Projection Screen Retractable, matte white screen Dimensions: 58" X 104" (119" diagonal) Aspect Ratio:16:9 Form Factor: Wall/Ceiling Mount White finish preferred Compatible remote controls (see next line item)	1,245.00	2,490.00
2	<u>Dalite 98662 Remote Control</u> (or equal, compatible with alternative projection screen bid.)	165.00	330.00
2	<u>Spectrum 55218 CHBHD Compact Lectern</u> Black and Cherry cabinet facing Rack Rail 28" front - 16 rack units (19" D) Locking Doors, front and back (if both are available) Locking Balloon Wheels 20" Retractable Power Cord 8-Outlet Power Strip Perforated Panels for Heat Dissipation	1,075.00	2,150.00
2	Spectrum 55219 CHB Flip Up Shelf (MATCH LECTERN)	225.00	450.00
2	Spectrum 55219 CHB Flip Up Shelf (MATCH LECTERN)	146.00	584.00
4	Spectrum CHB 97505 Shelf (MATCH LECTERN)	155.00	310.00
2	Spectrum 95002 CHB Riser Podium (MATCH LECTERN)	5.50	11.00
2	Spectrum 55142 (Extra Set of Keys) (MATCH LECTERN)		

1	<p align="center"><u>Spectrum 38245 BL Instructor's Stool</u></p> <ul style="list-style-type: none"> • Pneumatic height adjustment • Trouble-free chrome foot ring • Easy-to-use ratchet back • Tilting backrest • Sliding seat • Back angle adjustment • Oversized casters 	305.00	305.00
2	<p align="center"><u>Sony SCVD380P DVD/VCR Player</u> (include Coaxial and RCA Cables)</p> <ul style="list-style-type: none"> • Progressive Output (480p) for DVD Player • Multi Brand TV Remote Control substitute Toshiba SD-V296 • CD, MP3, and JPEG Playback • 4-Head High-Fidelity Stereo 	100.00	200.00
2	<p align="center"><u>Crestron TPS4000 10.4" Color Touch Panel</u></p> <p align="center">640 X 480 Resolution Aspect Ratio: 4:3 VGA Brightness: 450 nits Contrast: 600:1 Color: 18-bit 256k 32-bit Processor</p> <p align="center">Memory: DRAM: 8MB, Flash: 8MB</p> <p align="center">Accepts NTSC(480i)/(576i)PAL Composite for S-Video source</p> <p align="center">Volume Control; Audio Mixer Line-Level Stereo input</p> <p align="center">Built-In Amplified Stereo Speakers (2 watts/channel)</p> <p align="center">Microphone (Headphone) with automatic gain control and line-level output (3.5mm TRS mini phone jack)</p> <p align="center">Adjustable Screen Tilt (30 to 80 degrees) Dimensions: 10.3"h x 10.96"w x 9.32" d</p>	2,665.00	5,330.00
2	<p align="center"><u>Crestron MPS 300 Multimedia Presentation System</u></p> <p align="center">32-bit Micro-Processor Resolution: QXGA 2048 X1536 @ 60Hz</p> <p align="center">Memory: SDRAM 32MB; NVRAM 256KB; FLASH 16MB</p> <p align="center">Operating System: Supports SIMPL Windows, Real-Time, multi-tasking and multi-threading, FAT32 file system (long name support)</p> <p align="center">Network Connectivity and Support: Three (3) Quick Media and one (1) CAT5 Outputs 10/100BaseT, static IP or DHCP/DNS, SSL, full-duplex TCP/IP, UDP/IP, CIP, SMTP, SNMP</p> <p align="center">Video: Signal Input Types: 3 RGB and composite, S-Video, or component video</p> <p align="center">Video Input Types: NTSC or PAL, 2 HDTV up to 1080i/1080p Switcher: 8x7 cross point matrix with 3x3 QM signal routing, local QM delay</p>	3,555.00	7,110.00

	<p>skew compensation and RGB pass-thru mode</p> <p>Switcher/Preamp:</p> <p>8x4 stereo cross point matrix with, 3x3 QM signal routing, 2-channel gated microphone preamp with compressor and limiter; 8-channels microphone EQ; 10x5 microphone/program matrix mixer; 8x2 microphone matrix mixer per each 3 QM outputs; mono volume/tone control and EQ/delay on speech output; integrated power amplifier; QM auto-compensating with self-peaking 40-watt built-in amplifier</p> <p>Additional Features:</p> <p>Two (2) RS-232, four (4) IR, 4 digital in, 8x4 relay control ports Front panel setup and control; Keypad, touch panel and wireless control options; 2U rack-mountable</p>		
2	<p><u>Crestron OM-RX OM Receiver</u></p> <p>Signal Types: RGB and composite, S-Video, or component video</p> <p>Video/HDTV Formats: NTSC or PAL, HDTV up to 1080i/p</p> <p>Maximum Resolution: 1920x1200 @60Hz</p> <p>Front Panel Connectors:</p> <p>One (1) 8-wire RJ45 female input port; Two (2) 4-pin 3.5mm detachable terminal blocks</p> <p>Rear Panel Connectors:</p> <p>RGBHV, S-Video, Video (BNC), DB9 Bidirectional RS-232, IR/Serial Port</p>	725.00	1,450.00
2	<p><u>Crestron CNPWS-75 Power Supply</u></p> <ul style="list-style-type: none"> • 75 Watts (3.125 Amps) @ 24 Volts DC regulated • (2) 4-pin 5mm detachable terminal blocks; Power output ports, paralleled; Data 'Y' and 'Z' terminals pass-through only • IEC320 Socket; • Mates with removable power cord, included • Freestanding or 2U 19-inch rack-mountable • 2.55" H x 4.74"W x 8.07" D 	250.00	500.00
2	<p><u>TrippLite TRPS500RT1U Rack Mount UPS</u></p> <p>new model number smart 500RTTU 500VA 1U rack/tower UPS (wall-mount or under lectern mounting) Five (5) outlets: four (4) UPS/surge, one (1) surge only SNMP-Compatible DB9 Serial Port for Network Interface EMI/RFI Noise Filtering Diagnostic LEDs 6-foot cord Power Alert Software, 6-foot network cable and mounting hardware Minimum \$250,000 Lifetime Warranty</p>	169.00	338.00
4	<p><u>Panasonic UB-8325 Electronic Whiteboard</u></p> <p>External Dimensions: 54.6"H x 61"W x 10.4"D Panel Dimensions: 35.4"H x 55.1"W</p>	2,000.00	8,000.00

	Panel Surface: Two (2) Endless scroll type) Scanning Image Sensors Interface: USB 2.0 Windows compatible Printing: Fusion thermal transfer type Copy: Standard letter size 8.5"x11"; 16-24 lb. Copy Color/Density: Black, 203dpi Copy Speed: 15 seconds per sheet, up to nine (9) sheets continuous Two (2) Screen Compressed Copying Electronic Pen and Electronic Eraser: minimum expectancy 40 hour battery life Features: Drawing Tool; Screen Capture; Screen Print; Board Image Capturing; Handwriting Recognition (English) <u>Consumables:</u> Two (2) sets KX-B035 Marker and Eraser Kit (1 Black pen, 1 Red pen, 1 Blue pen, 1 Eraser) Eraser Cloths: KX-BP0481 (set of 10)		
		38.50	154.00
		38.00	152.00
4	<u>Panasonic KX-B063 Wall-Mounting Kit</u> (or applicable to alternative Whiteboard offered.)	39.00	156.00
1	<u>Training:</u> Four (4) employees, one full eight (8) hour day	1,000.00	1,000.00
1	<u>Installation</u> Complete Installation (turn-key solution)	6,500.00	6,500.00
	TOTAL BID		87,629.75

All equipment must be new, not used, or refurbished. Complete delivery and installation must be completed within sixty (60) days of contract award. The fully executed purchase order shall serve as the Notice to Proceed and the date of the purchase order will determine the start of the 60 day installation period.

All equipment must carry a minimum of a one (1) year warranty (with the exception of the Multimedia Projector, which will have a 3 year warranty on parts and labor) with on-site support as required. Bids must be all-inclusive of travel expenses.



State of West Virginia
 Department of Administration
 Purchasing Division
 2019 Washington Street East
 Post Office Box 50130
 Charleston, WV 25305-0130

Request for Quotation

RFQ NUMBER
 DMV110150

PAGE
 1

ADDRESS CORRESPONDENCE TO ATTENTION OF
 FRANK WHITTAKER
 304-558-2316

RFQ COPY

TYPE NAME/ADDRESS HERE

Lee Hartman & Sons, Inc.
 3 Davis Court
 Hurricane WV 25526

DIVISION OF MOTOR VEHICLES

1317 HANSFORD STREET
 CHARLESTON, WV
 25311 558-0002

DATE PRINTED	TERMS OF SALE	SHIP VIA	F.O.B.	FREIGHT TERMS
04/18/2011	net 30	delivered	Dest	PPD

BID OPENING DATE: 05/18/2011 BID OPENING TIME 01:30PM

LINE	QUANTITY	UOP	CAT. NO.	ITEM NUMBER	UNIT PRICE	AMOUNT
***** ADDENDUM NO. 1 *****						
THIS ADDENDUM IS ISSUED TO EXTEND THE BID OPENING DATE AND TIME.						
THE BID OPENING IS CHANGED TO 05/18/2011 AT 1:30 PM						
***** END ADDENDUM NO. 1 *****						
0001	1	EA		840-99		
AUDIO, VIDEO DATA PROJECTION EQUIPMENT & COMPONENTS						
***** THIS IS THE END OF RFQ DMV110150 ***** TOTAL:						

SEE REVERSE SIDE FOR TERMS AND CONDITIONS

SIGNATURE <i>Danny T. Cox</i>	TELEPHONE 304-397-4100	DATE 5-17-2011
TITLE Area Manager	FEIN 540710361	ADDRESS CHANGES TO BE NOTED ABOVE

WHEN RESPONDING TO RFQ, INSERT NAME AND ADDRESS IN SPACE ABOVE LABELED 'VENDOR'



State of West Virginia
 Department of Administration
 Purchasing Division
 2019 Washington Street East
 Post Office Box 50130
 Charleston, WV 25305-0130

Request for Quotation

RFQ NUMBER
 DMV110150

PAGE
 1

ADDRESS CORRESPONDENCE TO ATTENTION OF
 FRANK WHITTAKER
 304-558-2316

RFQ COPY

VENDOR

Lee Hartman & Sons
 3 Davis Court
 Hurricane, WV 25526

SHIP TO

DIVISION OF MOTOR VEHICLES
 1317 HANSFORD STREET
 CHARLESTON, WV
 25311 558-0002

DATE PRINTED	TERMS OF SALE	SHIP VIA	F.O.B.	FREIGHT TERMS
04/29/2011	net 30	delivered	Dest	PPD

BID OPENING DATE: 05/18/2011 BID OPENING TIME 01:30PM

LINE	QUANTITY	UOP	CAT NO	ITEM NUMBER	UNIT PRICE	AMOUNT
***** ADDENDUM NO. 2 *****						
THIS ADDENDUM IS ISSUED TO PROVEDE THE ATTACHED MANDATORY PRE-BID SIGN IN SHEET AND CHANGE THE SPECIFICATIONS AS FOLLOWS.						
THE SANYO PDG-DH100L DLP MULTIMEDIA PROJECTOR IS CHANGED TO PDG-DHT8000LDLP OR EQUAL. BRIGHTNESS IS CHANGED TO A MINIMUM OF 8000 ANSI LUMENS ALL OTHER SPECIFICATIONS REMAIN THE SAME.						
***** END ADDENDUM NO. 2 *****						
0001	1	EA		840-99		
AUDIO, VIDEO, DATA PROJECTION EQUIPMENT & COMPONENTS						
***** THIS IS THE END OF RFQ DMV110150 ***** TOTAL: _____						

SEE REVERSE SIDE FOR TERMS AND CONDITIONS

SIGNATURE <i>Randy T. Cox</i>	TELEPHONE 304-397-4100	DATE 5-17-2011
TITLE Area Manager	FEIN 540716361	ADDRESS CHANGES TO BE NOTED ABOVE

WHEN RESPONDING TO RFQ, INSERT NAME AND ADDRESS IN SPACE ABOVE LABELED 'VENDOR'

SIGN IN SHEET

PLEASE PRINT

Request for Proposal No.

* PLEASE BE SURE TO PRINT LEGIBLY - IF POSSIBLE, LEAVE A BUSINESS CARD

TELEPHONE & FAX NUMBERS

FIRM & REPRESENTATIVE NAME	MAILING ADDRESS	TELEPHONE & FAX NUMBERS
Company: Dmv - Purchasing	1317 Hansford St.	PHONE 304-558-2232
Rep: Karen Lane	Chas WU	TOLL FREE -
Email Address: Karen.J.Lane@wv.gov		FAX 304 558 4464
Company: heehartman's Sons	3 Davis Court	PHONE 304 881 8740
Rep: Rip McCher	Harrison wv 25526	TOLL FREE 397 4100
Email Address: emcchere@heehartman.com		FAX 304 397 4101
Company: Grandview Systems Inc.	4200 1st Ave.	PHONE 304-204-1392
Rep: Tom Sizemore	Suite 114	TOLL FREE
Email Address: tsizemore@gsivw.com	Nitro, WV 25743	FAX 304-204-1394
Company: Electronic Security Co.	1325 Dunbar Ave	PHONE 304.766.6277
Rep: Mark Wood	Dunbar, WV 25304	TOLL FREE 800.692.5590
Email Address: mark@electronicsecurity.com		FAX 304.766.6277
Company: Longs Security Camera Systems LLC		PHONE 304-925-0338
Rep: Alan E Long		TOLL FREE
Email Address: longscats@sidderint.net		FAX 304-925-0338

SIGN IN SHEET

Request for Proposal No.

PLEASE PRINT

*** PLEASE BE SURE TO PRINT LEGIBLY - IF POSSIBLE, LEAVE A BUSINESS CARD**

TELEPHONE & FAX NUMBERS

FIRM & REPRESENTATIVE NAME	MAILING ADDRESS	TELEPHONE & FAX NUMBERS
Company: <u>Newtech Systems</u>	<u>NewTech Systems Inc</u>	PHONE <u>304-766-0000</u>
Rep: <u>Scott Wood</u>	<u>420 16th St</u>	TOLL FREE
Email Address: <u>Swood@newtechwv.com</u>	<u>DUNBAR, WV 25064</u>	FAX <u>304-766-0003</u>
Company: <u>Verizon</u>	<u>4800 Mae Corle Ave</u>	PHONE <u>304-356-3541</u>
Rep: <u>Randy Jones</u>	<u>Charleston 25305</u>	TOLL FREE
Email Address: <u>randall.r.jones@verizonbusiness.com</u>		FAX
Company: <u>DMV-Commissioner's Office</u>		PHONE <u>304-926-3818</u>
Rep: <u>Mark Holmes</u>		TOLL FREE
Email Address: <u>Mark.a.holmes@wv.gov</u>		FAX
Company: <u>DMV Commissioner's Office</u>		PHONE <u>304-926-3945</u>
Rep: <u>Patricia M. Wehrle</u>		TOLL FREE
Email Address: <u>pat.m.wehrle@gov</u>		FAX
Company: <u>DMV Information Technology</u>		PHONE
Rep: <u>Wilbur L. Thaxton II</u>		TOLL FREE
Email Address: <u>Wilbur.L.Thaxton@wv.gov</u>		FAX

Get the film-like imaging of DLP® technology with new BrilliantColor™ color reproduction in a Large Venue High Definition projector.

EIP-HDT30

Key Features

- ◆ Full HD 1080p resolution. 8000 Lumens brightness. 7,500:1 contrast ratio.
- ◆ Single Chip DLP® imaging technology delivers a "seamless" image.
- ◆ Upscales 720p. Supports other widescreen and standard aspect ratios.
- ◆ Included 6-segment dual color wheel set can be installed, for Rich Color.
- ◆ 2 fixed inputs include a full suite of standard professional connections.
- ◆ 2 module bays permit customization. Built-in LAN Control Port.
- ◆ Optional modules include Dual (HD/SD) SDI and HD Wireless Receiver.
- ◆ Both horizontal & vertical power lens shift. Built-in Mechanical Shutter.
- ◆ Power Zoom and Focus. Optional Wideangle and Telephoto lenses.
- ◆ Centered lens and one-way airflow simplify installation. Quick lens installation
- ◆ Dual Lamp System provides redundancy and permits 4 brightness levels.
- ◆ Illuminated control panel & wireless/wired remote. RS-232 & Network control.
- ◆ Power Management, Keylock Security, and Custom Warmup Screen options.
- ◆ 3 Year* Projector Warranty!

Outstanding Features

1. 1080p at 8000 Lumens, 7500:1 Contrast, with DLP® imaging.
2. User-changeable color wheels to optimize brightness or color.
3. Lamp Interval Timer permits alternate 1-lamp-ON in 24/7 use.
4. Low Maintenance: up-to 35,000 hour cartridge air filter.
5. Extended Use: liquid-cooled DMD®, sealed optical engine.
6. Picture-in-Picture. Picture-by-Picture. Edge Blending.
7. Power zoom, focus, lens shift. Range of lenses and modules.

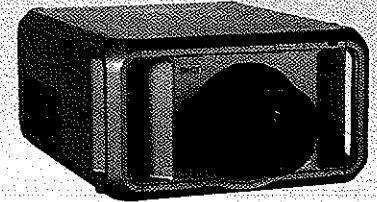

**8,000 Lumens
Full HD-1080p DLP® Theater Projector
with enhanced color reproduction**



Projectors... and more!

EIP-HDT30 Full HD-1080p DLP® Projector 8,000 ANSI Lumens

SPECIFICATIONS:

Brightness	up to 8,000 ANSI Lumens (**w/lens AH-430055) ("Dynamic" image mode & DynamicBlack™ Off)
Illumination Uniformity	90%
Color Reproduction	10 bit/1.07 Billion Colors
Contrast Ratio	up to 7,500:1 (w/DynamicBlack™ high)
Projection Lamp	330 Watt VIDI™ UHP x 2
Estimated Lamp Life	up to 3000 Hours of Use
Imaging System	0.95" DarkChip™ 1-chip DLP x 1
Native Resolution	1920x1080 (16:9 aspect ratio)
Color System	High Brightness 4-segment color wheels x 2 (installed)
Lens	Not Included (choose from a selection of optional lenses)
Image Diagonal	50-600 in
Image Width	3.64-43.6 ft (1.11-13.20 m)
Throw Distance	See specifications of selected lens
Front Elevation / Maximum Pitch	up to 5° up/360°
Vertical Anti Keystone	Power Lens Shift (Top:Bottom) 6.65:1 ~ 1:6.65
Horizontal Anti Keystone	Power Lens Shift (L:R:R:L) 10.7:1 ~ 1:10.7
Vertical Keystone Correction	Digital: up to 30° up or down
Horizontal Keystone Correction	Digital: up to 30° left or right
Scanning Frequency	Auto: H Sync. 15-120 kHz; V Sync. 48-120 Hz
Dot Clock	up to 230 MHz
Image Orientation	Normal, Reversed, Inverted
Local Control / Power Management	Full Function / Auto Shut-Off
Remote Projector Control	Wireless / Wired x 1
Wired Remote Port	MiniStereo x 1
Projector Service Port	USB-B x 1
RS-232 (Serial) Port / In & Out	Dsub 9-pin x 1
Wired LAN Control Port	RJ45 x 1
Computer: Compatibility	UXGA (analog only), WUXGA-WXGA, SXGA+ -VGA & MAC (analog or digital)
Computer: Formats	1920x1200 through 640x480
Computer: Image Sizing	Normal, or Smart Compressed or Expanded
Video: Color Systems	NTSC / PAL / SECAM / NTSC 4.43 / PAL-M&N
Video: Aspect Ratios Supported	16:9, 4:3 and other
Video: Image Resizing	Video Scaling Technology
Video: Resolutions Supported	
SDTV (Composite, S-Video, Component)	480i/p, 575i/p
HDTV	720p 1080i/p, 1080 p/30/25/24
Signal Inputs: fixed	
1. a. Computer: Analog RGB	Dsub15 x 1
b. Computer: Digital RGB	DVI-D x 1
or Video: Digital Video w/HDCP	
c. Video: Digital Video (w/HDCP)	HDMI x 1
2. a. Computer: Analog RGBHV	BNC x 5
or Video: Composite / Component: Video / Y-Pb/Cb-Pr/Cr	
b. Video: S-Video	S-Video x 1
Signal Inputs: modules	
3. Empty module bay (unpopulated)	
4. Empty module bay (unpopulated)	
Signal Outputs:	
Data / Video Monitor: Analog RGB / Composite / Component	Dsub15 x 1
Operating Noise	as low as 35 dBA
Cabinet Size (HxWxD)	9.6 x 15.7 x 20.6 in (242.5 x 400 x 524.2 mm)
Weight	43.2 lb (19.6 kg)
Packaged Size (HxWxD)	17.3 x 20.8 x 25.6 in (439 x 528 x 651 mm)
Packaged Weight	54.2 lb (24.6 kg)
Power Requirements	100-240V AC, 50/60Hz
Power Consumption	up to 963W Standard Mode
Heat	up to 3286 BTU/hr (772Kcal/hr)
Power Cord	Type 3, Detachable
Electrical Safety Compliance	UL / cUL
Electromagnetic Compatibility	FCC Part 15 Class A
Security	Kensington® Security Slot, Handles (use as Security Bar)
Operating Temperature	41-104°F (5-40°C)
User Maintenance	Replace Air Filter, Replace Lamps
Warranty: (to the original end-user customer)	
Projector:	3 Years (Parts & Labor to Correct Defects)
Lamp:	6 months ownership / 500 hours use (whichever occurs first)

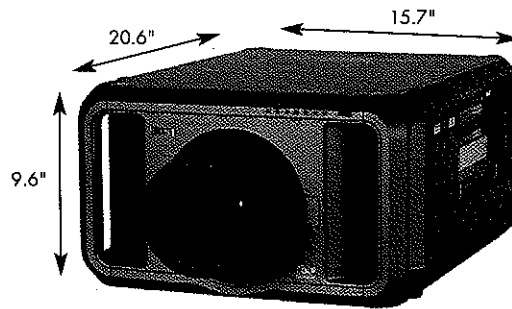

EIP-HDT30 – Full HD-1080p DLP® Theater Projector with enhanced color reproduction.

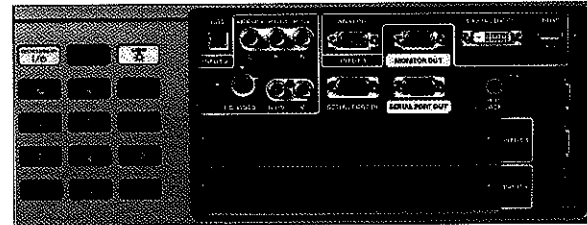

Complete local control, professional inputs, network module & expansion bay.



Top-accessed color wheels & lamps.

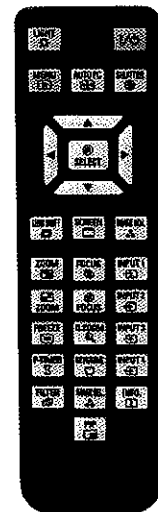
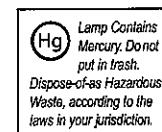

Full-function remote control.

INCLUDED ACCESSORIES:

Quick Setup Guide. Owner's Manual on CD-ROM. 6 ft (1.8 M) AC Power Cord. Lens Cover. VGA-type Computer Input Cable (Dsub15). Wireless/wired Remote & 2 x AA batteries. Wired Remote Cable. Real Color Manager Pro Software on CD-ROM x 1. Cable Cover x 1. Cable Cover Support x 1. Cable tie x 3. Rich Color 6-Segment Color Wheels x 2. Lens Aperture Cover.

OPTIONAL ACCESSORIES:

Wideangle, Standard and Telephoto Lenses. Replacement Lamps. Replacement Filter Cartridge. ATA-Style Shipping Case with Wheels and Telescoping Handle. Dual SDI Module (only HD-SDI can be used). DVI (only) Module. DVI-D & Dsub15 Module. 5BNC Module. 5BNC & S-Video Module. Dsub15 Module. Network Module. Ceiling Mount. Ceiling Post and Plate. HD Data Wireless Receiver Module. HD Wireless Transmitter.

EIKI® is a registered trademark of Eiki International, Inc.

Eiki International, Inc.

30251 Esperanza, Rancho Santa Margarita, CA 92688-2130

Tel: 800-242-3454; Fax: 800-457-3454, E-mail: usa@eiki.com

In Canada, 310 First St. Unit 2, P.O. Box 156, Midland, ON L4R 4K8

Phone: 800-563-3454, Fax: 800-567-4069 E-mail: canada@eiki.com

<http://www.eiki.com>

EIKI®

Projectors... and more!

Specifications subject to change without notice.

©2010 Eiki International, Inc. Printed in the USA. 09/1/10



Projectors... and more!

EIP-HDT30

Full HD 1080p DLP® Theater Projector

KEY FEATURES: Model EIP-HDT30

- Full HD 1080p resolution. 8,000 Lumens bright. 7,500:1 contrast ratio.
- Single Chip DLP® imaging technology delivers a "seamless" image.
- Upscales 720p. Supports other widescreen and standard aspect ratios.
- Included 6-segment dual color wheel set can be installed for rich color.
- 2 fixed inputs include a full suite of standard professional connections.
- 2 module bays permit customization. Built-in LAN Control Port.
- Optional modules include Dual (HD/SD) SDI and HD Wireless Receiver.
- Power Zoom and Focus. Optional Wideangle and Telephoto lenses.
- Both horizontal & vertical power lens shift. Built-in Mechanical shutter.
- Centered lens and one-way airflow simplify installation. Quick lens installation.
- Dual Lamp System provides redundancy and permits 4 brightness levels.
- Illuminated control panel & wireless/wired remote. RS-232 & Network control.
- Power Management, Keylock Security, and Custom Warmup Screen options.
- 3 Year Projector Warranty!

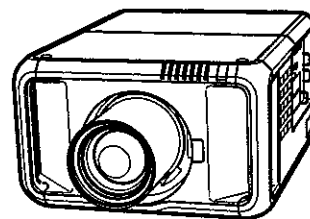

EIP-HDT30 (shown with optional lens)

Included Accessories: Quick Setup Guide, Owner's Manual on CD ROM. 6.0 ft. (1.8 M) AC Power Cord. Lens Cover. VGA-type Computer Input Cable (Dsub 15). Wireless/wired Remote & 2 x AA batteries. Wired Remote Cable. Real Color Manager Pro Software on CD-ROM. Lens Aperture Cover. Cable Cover x 1. Cable Cover Support x 1. Cable Cover Ties x 3. Rich Color 6-Segment Color Wheels x 2. Network Software on CD-ROM.

Optional Accessories: Wideangle, Standard and Telephoto Lenses. Replacement Lamps. Replacement Filter Cartridge. ATA-Style Shipping Case with Wheels and Telescoping Handle. Dual SDI Module (only HD-SDI can be used). DVI (only) Module. DVI-D & Dsub15 Module. 5BNC Module. 5BNC & S-Video Module. Dsub15 Module. Network Module. Ceiling Mount. Ceiling Post and Plate. HD Data Wireless Receiver Module. HD Wireless Transmitter.

Outstanding Features:

- | | |
|--|---|
| 1. 1080p at 8000 Lumens, 7500:1 Contrast, with DLP® imaging. | 4. Low Maintenance: up-to 35,000 hour cartridge air filter. |
| 2. User-changeable color wheels to optimize brightness or color. | 5. Extended Use: Peltier device cooled DMD®, sealed optical engine. |
| 3. Lamp Interval Timer permits alternate 1-lamp-ON in 24/7 use. | 6. Picture-in-Picture. Picture-by-Picture. Edge Blending. |
| | 7. Power zoom, focus, lens shift. Range of lenses and modules. |

SPECIFICATIONS: Model EIP-HDT30

Screen Brightness	up to 8,000 ANSI Lumens (**w/lens AH-43005S)	Video: Image Sizing	Video Scaling Technology
	("Dynamic" Image mode & DynamicBlack™ Off)	Video: Resolutions Supported	
Illumination Uniformity	90%	SDTV (Composite, S-Video, Component)	480i/p, 575i/p
Size of Color Palette	10 bit / 1.07 Billion Colors	HDTV	720p, 1080i/p, 1080 psp 30/25/24
Contrast Ratio	over 7,500:1 (w/DynamicBlack™ high)	Signal Inputs: fixed	
Horizontal Resolution	550 TV Lines (HDTV)	1 a. Computer: Analog RGB	Dsub 15 x 1
Projection Lamp	330 Watt VID™ UHP x 2	b. Computer: Digital RGB	DVI-D x 1
Estimated Lamp Life	up to 3000 Hours of Use	or Video: Digital Video w/HDCP	
Imaging System	0.95" DarkChip™ 1-chip DLP® x 1	c. Video: Digital Video w/HDCP	HDMI x 1
Native Resolution	1920x1080 (16:9 aspect ratio)	2 a. Computer: Analog RGBHV	BNC x 5
Color System	High Brightness 4-segment color wheels x 2 (installed)	or Video: Composite/Component: Video / Y-Pb/Cb-Pr	
Lens Type	Not Included (choose from a selection of optional lenses)	b. Video: S-Video:	S-Video x 1
Image Diagonal	50~600 in. (127~1524 cm)	Signal Inputs: Modules	
Image Width	3.64~43.6 ft. (1.11~13.20 m.)	3. Empty module bay (unpopulated)	
Throw Distance	See specifications of selected lenses	4. Empty module bay (unpopulated)	
Front Elevation / Maximum Pitch	up to 5° up / 360°	Signal Outputs:	
Vertical Anti Keystone	Power Lens Shift (Top:Bottom) 21:-1~1:21	Data/Video Monitor: Analog RGB / Composite/Component Dsub 15 x 1	
Horizontal Anti Keystone	Power Lens Shift (L:R~R:L) 3:1~1:3	Operating Noise	as low as 35 dBA
Vertical Keystone Correction	Digital: up to 30° up or down	Cabinet Size (HxWxD)	9.6 x 15.7 x 20.6 in. (242.5 x 400 x 524.2 mm.)
Horizontal Keystone Correction	Digital: up to 30° left or right	Weight	43.2 lb. (19.6 kg)
Scanning Frequency	Auto: H Sync. 15-120 kHz; V Sync. 48-120 Hz	Packaged Size	17.3 x 20.8 x 25.6 in. (439 x 528 x 651mm.)
Dot Clock	up to 230 MHz	Packaged Weight	54.2 lb (24.6 kg)
Image Orientation	Normal, Reversed, Inverted	Power Requirements	100-240V AC, 50/60Hz
Local Control / Power Management	Full Function / Auto Shut-Off	Power Consumption	up to 963W Standard Mode
Remote Projector Control	Wireless/wired x 1	Heat	up to 3286 BTU/hr.
Projector Service Port	USB-B x 1	Power Cord	Type 3, Detachable
Wired Remote Port	MiniStereo x 1	Electrical Safety Compliance	UL / cUL
RS-232 (Serial) Port / In & Out	Dsub 9-pin x 2	Electromagnetic Compatibility	FCC Part 15 Class A
Wired LAN Control Port	RJ45 x 1	Security	Kensington® Security Slot, Handles (use a Security Bar)
Computer: Compatibility	WUXGA (Analog only)	Operating Temperature	41~104°F (5~40°C)
	UXGA ~ WXGA, SXGA+ ~ VGA & MAC (analog & digital)	User Maintenance	Replace Air Filter, Replace Lamps
Computer: Formats	1920 x 1200 through 640 x 480	Warranty (to original end use customer)	
Computer: Image Sizing	Normal, or Smart Compressed or Expanded	Projector :	3 Years
Video: Color Systems	NTSC/PAL/SECAM/NTSC 4.43 / PAL-M&N	Lamp : .. 6 months ownership / 500 hours use (whichever occurs first)	
Video: Aspect Ratios Supported	4:3 & 16:9		

Lamp contains Mercury. Do not put in trash. Dispose of as Hazardous Waste, according to Local, State or Federal Laws.

Specifications subject to change without notice. ©2010 Eiki International, Inc. Issued September 1, 2010.

Eiki International, Inc., 30251 Esperanza, Rancho Santa Margarita, CA 92688-2132. Tel: 800-242-3454; Fax: 800-457-3454, E-mail: usa@eiki.com

In Canada: 310 First St., Unit 2, P.O. Box 156, Midland, ON L4R 4K8. Tel: 800-563-3454, Fax: 800-567-4069, E-mail: canada@eiki.com

Visit our World Wide Web site: <http://www.eiki.com>

TOSHIBA

Leading Innovation >>>

SD-V296
DVD/VCR Combo Player

Fitting more entertainment value into less shelf space just got easier. With a DVD/VCR combo player, you get the connectivity and features without the clutter.

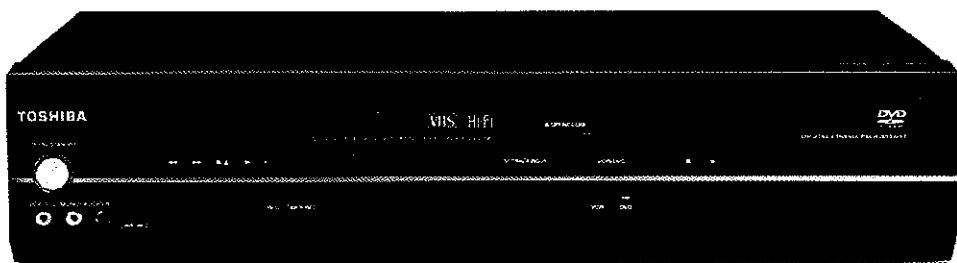

ADVANTAGE

Combines the picture and sound advantages of a **progressive scan DVD player** with the convenient recording^{1,2} and playback options of a **video cassette recorder** - all in one slim chassis.

One Touch Recording for the VCR provides a simple and convenient way to make a recording. Simply connect your DVD/VCR to your cable or satellite box and then to your monitor/TV and you are set to record a tape with the push of one button!

ColorStream Pro® Progressive Scan Component Video Outputs compatible with today's finest analog and digital televisions for delivery of stunningly colorful images.

Simultaneous DVD playback and VHS Record for watching a DVD while recording a TV program.

JPEG Viewer³ enables a user to display digital photographs on a television set in the JPEG digital format.

PRELIMINARY

LEADING THE WAY IN
HOME ENTERTAINMENT
INNOVATION

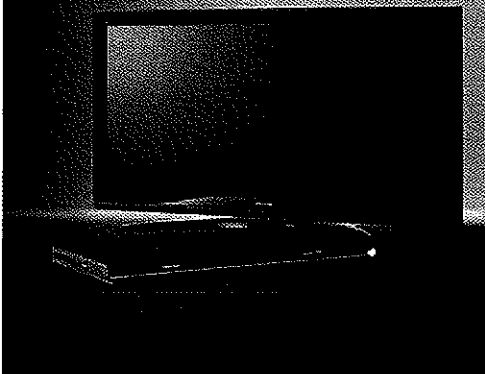

SD-V296

Specifications

PLAYABLE DISC TYPES

DVD-Video/DVD-R/DVD
RW/CD/CD-R/CD-RW/VCD

DVD VIDEO

Video D/A Converter	108MHz/14-Bit
Component Video Output	ColorStream Pro®
Progressive Scan	•
JPEG Viewer	•
Digital Picture Zoom	•
Fast Scan	•
Slow Motion	•
Multi-Camera Angle Select	•
Multi-Language Select	•
Multi-Subtitle Select	•

DVD AUDIO

Audio D/A Converter	192kHz/24-Bit
Dolby® Digital/DTS® Compatible	•
3D Surround Sound	•

DVD CONVENIENCE

Parental Lock	•
---------------	---

VCR VIDEO

Video Heads	4
Record Speeds	SP/SLP (EP)
SQPB	•

VCR AUDIO

Hi-Fi VHS Stereo	•
------------------	---

VCR CONVENIENCE

Commercial Skip	•
OSD Language	English/French/Spanish
Remote Control	DVD/VCR Remote
Hi-speed Rewind	•

TERMINALS

ColorStream Pro® Component	•
Video Outputs	1 rear - DVD only
S-Video Out	1 rear - DVD only
RCA-Video Out	1 rear - both
RCA-Video In	1 front & 1 rear
L-R Audio Out	1 rear
L-R Audio Inputs	1 front & 1 rear
Coaxial Digital Audio Output	1 (DVD only)

PRODUCT & PACKAGING

Unit Dimensions (WHD) in.	17.13 x 3.7 x 9.17
Carton Dimensions	21.22 x 7.17 x 13.46
Unit Weight	5.94 lbs
Carton Weight	7.7 lbs
UPC Code	022265001844

¹External tuner source required to record television programming.

²This product is not made or sold for unauthorized use of copyrighted works, and it is only intended for recording and playback of authorized content and any other lawful use.

³Some DVD-R/DVD-RW and CD-R/CD-RW discs may be incompatible due to laser pick up and disc design. CD-R/CD-RW discs must be recorded using CD-DA method for CD audio playback. The DVD player may not support some MP3/WMA/JPEG/DivX recordings due to differences in recording formats, disc structure, or condition of the disc (use of CD-RW for MP3 files is not recommended). See owner's manual for more information.

<http://www.tacp.toshiba.com> Customer Solutions: 800.631.3811

© Toshiba America Consumer Products, L.L.C.

82 Totowa Road, Wayne, NJ 07470 (2008). All Rights Reserved (7/08.1)

ColorStream Pro is a registered trademark of Toshiba America Consumer Products, L.L.C. Dolby and the double-D symbol are registered trademarks of Dolby Laboratories. DTS is a registered trademark & the DTS logos and Symbol are trademarks of DTS, Inc. DivX, DivX Certified, and associated logos are trademarks of DivX, Inc. and are used under license.

Product design and specifications subject to change or modification without notice.



Tripp Lite
1111 West 35th Street
Chicago, IL 60609 USA
Telephone: +(773) 869 1234
E-mail: saleshelp@tripplite.com

Model #: SMART500RT1U

SmartPro .5kVA Line Interactive UPS, SNMPWEBCARD option, 1U Rack/Tower, USB, Serial, EPO, 120V

Highlights

- 500VA line interactive 1U rack/tower UPS
- 6 outlets with 1 switchable load bank
- Simultaneous communications via SNMPWEBCARD slot, USB and DB9 serial ports
- Included PowerAlert UPS monitoring software manages an unlimited number of network UPS systems
- Built-in voltage regulation corrects brownouts to 90V
- \$250,000 Ultimate Lifetime Insurance (USA, Puerto Rico & Canada only)



Description

Tripp Lite's SMART500RT1U intelligent, line interactive rack/tower uninterruptible power supply prevents data loss, downtime and equipment damage due to power outages, voltage fluctuations and transient surges. Requires only one rack space (1U) in a 2 or 4 post rack, with included accessories for upright tower placement. Large internal batteries offer 8 minutes half load runtime and 3 minutes at full load. Maintains regulated 120V nominal output without using battery power during brownouts as low as 90V. 500VA/300 watt power handling capability is compatible with networking, telecom and other sensitive electronic applications. Includes 6 UPS supported outlets with a single outlet load bank that can be individually controlled via software interface to reboot select equipment on demand or shed less significant loads to extend battery runtime for more critical equipment. Includes 1 surge-only outlet for peripherals not requiring battery backup. Supports simultaneous remote monitoring of UPS and site power conditions via built-in USB and DB9 monitoring ports. Includes PowerAlert UPS monitoring and unattended shutdown software with complete cabling. Built-in accessory slot supports SNMP with optional SNMPWEBCARD adapter. Emergency Power Off (EPO) interface offers option for instantaneous power-off of UPS and connected equipment in the case of fire or emergency situation. Multi-function audible alarms and set of 5 front panel LEDs offer at-a-glance notification of UPS and line power status. Network-grade AC surge suppression protects equipment from damage and performance problems resulting from transient surges and line noise. Attractive all-black color scheme. Two year warranty with \$250,000 connected equipment insurance (USA & Canada only).

Package Includes

- SMART500RT1U UPS System
- Mounting hardware
- Cabling for USB & DB9 monitoring and EPO switching
- PowerAlert unattended shutdown and UPS/Power monitoring software
- Warranty information and instruction manual

Features

- SMART500RT1U line interactive UPS offers battery derived sine wave AC output during power outages, voltage regulation during brownouts, plus network-grade AC surge suppression
- 500VA/300 watt power handling capability compatible with networking, telecom and other sensitive electronic devices
- Supports 1U rackmount installation in 2 or 4 post rack enclosures, upright tower placement also supported - mounting accessories included
- Large internal batteries offer runtimes of 17 minutes at half load (250VA/150 watts) and 5 minutes at full load (500VA/300 watts)
- Maintains regulated 120V nominal output during brownouts as low as 90V

- Includes 6 UPS-supported outlets, with one pair of individually controllable outlets that can be powered off and back on again via software interface
- PowerAlert UPS monitoring and unattended shutdown software enables configurable network broadcast messaging, pager & email notification, event logging and running user-defined script commands
- Offers simultaneous monitoring by up to 3 directly-connected devices through included USB, DB9 and SNMP* interfaces (*requires optional SNMPWEBCARD), or the monitoring of any number of additional UPS systems over IP with included PowerAlert monitoring software. Free PowerAlert enterprise management software is also available for select opportunities
- Communications ports support messaging of UPS and line power status, including on-battery, low-battery, power restored, AC line voltage, DC battery voltage and remaining battery capacity
- Supports timed inverter shutoff after unattended shutdown, activate self-test and UPS output power control for scheduled or immediate reboot of connected devices
- Supports Tripp Lite's WatchDog software application to restore unresponsive programs by systematically restarting applications, operating systems and ultimately rebooting completely locked computers by momentarily switching UPS power off and back on again (requires optional WATCHDOGSW)
- Built-in accessory slot supports SNMP with optional SNMPWEBCARD adapter
- Emergency Power Off (EPO) interface with cable
- Multi-function audible alarms and set of 5 front panel LEDs
- Network-grade AC surge suppression
- Attractive all-black color scheme
- UPS battery set ships fully assembled and ready for installation, no time consuming connection of internal batteries by user is necessary
- Two year warranty with \$250,000 connected equipment insurance (USA & Canada only)

Specifications

OUTPUT	
Output Volt Amp Capacity (VA)	500
Output Watt Capacity (watts)	300
Output power factor	0.6
Nominal Output Voltage(s) Supported	120V
Frequency compatibility	60 Hz
Output voltage regulation (line mode)	-15%, +13%
Output voltage regulation (Battery mode)	+/- 5%
Built-in UPS output receptacles	7 5-15R outlet(s)
Surge suppression only outlets	6 UPS outlets, 1 surge-only outlets
Built-in controllable switched load banks	One switchable single-outlet 5-15R load bank
Basic PDU options	PDU1215 (1U / 13 5-15R outlets); PDUNV (1U / 2 C19, 12 C13 outlets); PDU1415 (0U / 14 5-15R outlets); PDUV15 (0U / 12 5-15R outlets)
Metered PDU options	PDUMH15 (1U / 13 5-15R outlets); PDUMH15AT (1U / 8 5-15R outlets)*; PDUMV15 (0U / 16 5-15R outlets)
Switched PDU options	PDUMH15ATNET (1U / 8 5-15R outlets)*; PDUMV15NET (0U / 16 5-15R outlets)
External PDU redundancy options	*Auto Transfer Switch features utilizing the secondary PDU input cord are compatible with Smart Online UPS models only
Output AC waveform (AC mode)	Sine wave

Output AC waveform (battery mode)	PWM sine wave
INPUT	
Rated input current (at maximum load)	5.6A
Nominal Input Voltage(s) Supported	120V AC
UPS input connection type	5-15P
Input circuit breaker	15A
UPS Input cord length (ft.)	10
UPS Input cord length (m)	4.5
Recommended Electrical Service	15A 120V
BATTERY	
Full load runtime (minutes)	3 min. (300w)
Half load runtime (minutes)	8 min. (150w)
DC system voltage (VDC)	12
Battery recharge rate (included batteries)	Less than 4 hours from 10% to 90%
Replacement battery cartridge (internal UPS battery replacement)	RBC62-1U
Battery Access	Battery access door
Battery replacement description	Hot-swappable, user replaceable batteries
VOLTAGE REGULATION	
Voltage regulation description	Automatic voltage regulation (AVR) maintains line power operation with input voltage as low as 90
Undervoltage correction	Input voltages between 90 and 108 are boosted by 14%
LEDS ALARMS & SWITCHES	
LED Indicators	5 LEDs indicate line power, battery power, overload, voltage regulation and battery low/replace status
Alarms	Audible alarm indicates power-failure, overload and low-battery conditions
Alarm cancel operation	Power-fail alarm can be silenced using alarm-cancel switch; once silenced, alarm will re-sound to indicate low-battery status
Switches	2 Switches control off/on power status and alarm-cancel/self-test operation
SURGE / NOISE SUPPRESSION	
UPS AC suppression joule rating	510 joules
EMI / RFI AC noise suppression	Yes
AC suppression joule rating	510

AC suppression response time	Instantaneous
PHYSICAL	
Installation form factors supported with included accessories	4 post 19 inch rackmount (mounting kit included); 2 post 19 inch rackmount (mounting kit included)
Primary form factor	Rackmount
UPS / Power Module dimensions in primary form factor (height x width x depth / inches)	1.7 x 17.5 x 11.8
UPS / Power Module dimensions in primary form factor (height x width x depth / cm)	4.4 x 44.4 x 29.8
Installed whole system total rack space height (rack spaces)	1U
UPS / Power Module weight (lbs)	17.6
UPS / Power Module weight (kg)	8
UPS Shipping dimensions (height x width x depth / inches)	5 x 22.5 x 16
UPS Shipping dimensions (height x width x depth / cm)	12.7 x 57.2 x 40.6
Shipping weight (lbs)	19.9
Shipping weight (kg)	9
UPS housing material	Steel
ENVIRONMENTAL	
Operating Temperature Range	+32 to +104 degrees Fahrenheit / 0 to +40 degrees Celsius
Storage Temperature Range	+5 to +122 degrees Fahrenheit / -15 to +50 degrees Celsius
Relative Humidity	0 to 95%, non-condensing
AC mode BTU / hr. (full load)	65.1
Battery mode BTU / hr. (full load)	287.7
COMMUNICATIONS	
Communications interface	USB; DB9 Serial; EPO (emergency power off); Slot for SNMP/Web interface
Network monitoring port description	Supports detailed monitoring of UPS and site power conditions
PowerAlert software	Included
Communications cable	USB and DB9 cabling included

WatchDog compatibility	Supports Watchdog application, OS and hard-reboot restart options for remote applications
LINE / BATTERY TRANSFER	
Transfer time	2-4 milliseconds
Low voltage transfer to battery power (setpoint)	90
High voltage transfer to battery power (setpoint)	136
SPECIAL FEATURES	
Grounding lug	Back panel grounding lug
Cold Start (startup in battery mode during a power failure)	Cold-start operation supported
High availability UPS features	Hot swappable batteries
Green & high efficiency features	Individually controllable load banks
CERTIFICATIONS	
UPS Certifications	Tested to UL1778 (USA); Tested to CSA (Canada); Tested to NOM (Mexico); Meets FCC Part 15 Category B (EMI)
WARRANTY	
Product Warranty Period (U.S., Canada & Puerto Rico)	2-year limited warranty
Connected Equipment Insurance (U.S., Canada & Puerto Rico)	\$250,000 Ultimate Lifetime Insurance

Related Items

Optional Products

Product Type	Related Model	Description	Qty.
Power Distribution	PDU1215	Basic PDU / Power Distribution Unit - Safe, reliable power distribution for critical networking equipment	-
Power Distribution	PS7224	Tripp Lite Power Strip - Multiple outlets wherever you need them	-
SNMP Accessories	SNMPWEBCARD	For remote monitoring and control via SNMP, Web, or Telnet.	-
SNMP Accessories	ENVIROSENSE	Monitors temperature, humidity and contact-closure inputs. (Requires SNMPWEBCARD or switched PDU.)	-
USB Hubs/Accessories	U022-010	10-ft. USB2.0 A/B Gold Device Cable (A Male to B Male)	-
Software	WATCHDOGSW	WatchDog Service Monitoring / Reboot Software	-
Audio Cables	CT120	Instant-Read- AC Outlet Circuit Tester	-
Surge Protectors	DNET1	Network Surge Suppressor - Essential protection for data and communication lines	-
Surge Protectors	DTEL2	Network Surge Suppressor - Essential protection for data and communication lines	-
Extended Warranties	WEXT3-500-1500	3-Year Extended Warranty - For Smart Line-Interactive and Online Tower or Rack models, 1500VA or less	-

Extended Warranties	WEXT5-500-1500	5-Year Extended Warranty - For Smart Line-Interactive and Online Tower or Rack models, 1500VA or less	-
UPS Accessories	MODBUSCARD	For remote monitoring and control via MODBUS protocol	-

More information, including related products, owner's manuals, and additional technical specifications, can be found online at www.tripplite.com/en/products/model.cfm?txtModelID=2853.

Copyright © 2011 Tripp Lite. All rights reserved. All trademarks are the sole property of their respective owners. Tripp Lite has a policy of continuous improvement. Specifications are subject to change without notice. Photos may differ slightly from final products.

ACORD CERTIFICATE OF LIABILITY INSURANCE

DATE (MM/DD/YYYY)

05/13/2011

PRODUCER (540) 343-4309
 Commercial Insurance Services, Inc.
 P. O. Box 21829
 5007 Carriage Drive
 Roanoke, VA 24018-

THIS CERTIFICATE IS ISSUED AS A MATTER OF INFORMATION ONLY AND CONFERS NO RIGHTS UPON THE CERTIFICATE HOLDER. THIS CERTIFICATE DOES NOT AMEND, EXTEND OR ALTER THE COVERAGE AFFORDED BY THE POLICIES BELOW.

INSURED
 LEE HARTMAN & SONS, INC.
 P. O. BOX 13365
 3236 COVE ROAD
 ROANOKE VA 24017-

INSURERS AFFORDING COVERAGE	NAIC #
INSURER A: STATE AUTO INSURANCE CO.	
INSURER B:	
INSURER C:	
INSURER D:	
INSURER E:	

COVERAGES

THE POLICIES OF INSURANCE LISTED BELOW HAVE BEEN ISSUED TO THE INSURED NAMED ABOVE FOR THE POLICY PERIOD INDICATED. NOTWITHSTANDING ANY REQUIREMENT, TERM OR CONDITION OF ANY CONTRACT OR OTHER DOCUMENT WITH RESPECT TO WHICH THIS CERTIFICATE MAY BE ISSUED OR MAY PERTAIN, THE INSURANCE AFFORDED BY THE POLICIES DESCRIBED HEREIN IS SUBJECT TO ALL THE TERMS, EXCLUSIONS AND CONDITIONS OF SUCH POLICIES. AGGREGATE LIMITS SHOWN MAY HAVE BEEN REDUCED BY PAID CLAIMS.

INSR LTR	ADD'L INSRD	TYPE OF INSURANCE	POLICY NUMBER	POLICY EFFECTIVE DATE (MM/DD/YY)	POLICY EXPIRATION DATE (MM/DD/YY)	LIMITS	
A		GENERAL LIABILITY <input checked="" type="checkbox"/> COMMERCIAL GENERAL LIABILITY CLAIMS MADE <input checked="" type="checkbox"/> OCCUR GEN'L AGGREGATE LIMIT APPLIES PER: <input type="checkbox"/> POLICY <input type="checkbox"/> PRO-JECT <input type="checkbox"/> LOC	PBP2575593	10/01/2010	10/01/2011	EACH OCCURRENCE	\$ 1,000,000
						DAMAGE TO RENTED PREMISES (Ea occurrence)	\$ 500,000
						MED EXP (Any one person)	\$ 10,000
						PERSONAL & ADV INJURY	\$ 1,000,000
						GENERAL AGGREGATE	\$ 2,000,000
						PRODUCTS - COMP/OP AGG	\$ 2,000,000
A		AUTOMOBILE LIABILITY <input checked="" type="checkbox"/> ANY AUTO ALL OWNED AUTOS SCHEDULED AUTOS <input checked="" type="checkbox"/> HIRED AUTOS <input checked="" type="checkbox"/> NON-OWNED AUTOS <input checked="" type="checkbox"/> PHYSICAL DAMAGE <input checked="" type="checkbox"/> HIRED CAR INCLUDED	BAP2305974	10/01/2010	10/01/2011	COMBINED SINGLE LIMIT (Ea accident)	\$ 1,000,000
						BODILY INJURY (Per person)	\$
						BODILY INJURY (Per accident)	\$
A		<input checked="" type="checkbox"/> PHYSICAL DAMAGE <input checked="" type="checkbox"/> HIRED CAR INCLUDED	BAP2305974	10/01/2010	10/01/2011	PROPERTY DAMAGE (Per accident)	\$
		GARAGE LIABILITY <input type="checkbox"/> ANY AUTO				AUTO ONLY - EA ACCIDENT	\$
						OTHER THAN EA ACC	\$
						AUTO ONLY: AGG	\$
A		EXCESS/UMBRELLA LIABILITY <input checked="" type="checkbox"/> OCCUR <input type="checkbox"/> CLAIMS MADE DEDUCTIBLE RETENTION \$ 0	PBP2575593	10/01/2010	10/01/2011	EACH OCCURRENCE	\$ 3,000,000
						AGGREGATE	\$ 3,000,000
							\$
							\$
A		WORKERS COMPENSATION AND EMPLOYERS' LIABILITY ANY PROPRIETOR/PARTNER/EXECUTIVE OFFICER/MEMBER EXCLUDED? If yes, describe under SPECIAL PROVISIONS below	WCP2171200 (VIRGINIA)	10/01/2010	10/01/2011	<input checked="" type="checkbox"/> WC STATUTORY LIMITS	OTHER
A			WCP2171206 (WEST VA)	10/01/2010	10/01/2011	E.L EACH ACCIDENT	\$ 500,000
						E.L DISEASE - EA EMPLOYEE	\$ 500,000
						E.L DISEASE - POLICY LIMIT	\$ 500,000
A		OTHER RENTAL EQUIPMENT	PBP2575593	10/01/2010	10/01/2011	LIMIT, \$500 DED	25,000
A		INSTALLATION FLOATER	PBP2575593	10/01/2010	10/01/2011	LIMIT, \$1000 DED	250,000

DESCRIPTION OF OPERATIONS/LOCATIONS/VEHICLES/EXCLUSIONS ADDED BY ENDORSEMENT/SPECIAL PROVISIONS

REQ. DMV110150, BID DUE DATE: 5/18/2011

JOB DESCRIPTION: WC DMV REQUESTING AV EQUIPMENT FOR TWO CONFERENCE ROOMS FOR COMMISSIONER OFFICES AT 5705 MACCORKLE AVENUE SE, CHARLESTON, WV.

CERTIFICATE HOLDER

() - () -
 STATE OF WEST VIRGINIA
 DEPT ADMIN. PURCHASING DIVISION
 P.O. BOX 50130, 2019 WASHINGTON
 CHARLESTON WV 25305-0130

CANCELLATION

SHOULD ANY OF THE ABOVE DESCRIBED POLICIES BE CANCELLED BEFORE THE EXPIRATION DATE THEREOF, THE ISSUING INSURER WILL ENDEAVOR TO MAIL 30 DAYS WRITTEN NOTICE TO THE CERTIFICATE HOLDER NAMED TO THE LEFT, BUT FAILURE TO DO SO SHALL IMPOSE NO OBLIGATION OR LIABILITY OF ANY KIND UPON THE INSURER, ITS AGENTS OR REPRESENTATIVES.

AUTHORIZED REPRESENTATIVE

Janet B. Trussell

BID BOND

KNOW ALL MEN BY THESE PRESENTS, That we, the undersigned, _____
_____ of _____, _____, as Principal, and _____
_____ of _____, _____, a corporation organized and existing under the laws of the State of _____
_____ with its principal office in the City of _____, as Surety, are held and firmly bound unto the State
of West Virginia, as Obligee, in the penal sum of _____ (\$ _____) for the payment of which,
well and truly to be made, we jointly and severally bind ourselves, our heirs, administrators, executors, successors and assigns.

The Condition of the above obligation is such that whereas the Principal has submitted to the Purchasing Section of the
Department of Administration a certain bid or proposal, attached hereto and made a part hereof, to enter into a contract in writing for

NOW THEREFORE,

- (a) If said bid shall be rejected, or
- (b) If said bid shall be accepted and the Principal shall enter into a contract in accordance with the bid or proposal attached
hereto and shall furnish any other bonds and insurance required by the bid or proposal, and shall in all other respects perform the
agreement created by the acceptance of said bid, then this obligation shall be null and void, otherwise this obligation shall remain in full
force and effect. It is expressly understood and agreed that the liability of the Surety for any and all claims hereunder shall, in no event,
exceed the penal amount of this obligation as herein stated.

The Surety, for the value received, hereby stipulates and agrees that the obligations of said Surety and its bond shall be in no
way impaired or affected by any extension of the time within which the Obligee may accept such bid, and said Surety does hereby
waive notice of any such extension.

IN WITNESS WHEREOF, Principal and Surety have hereunto set their hands and seals, and such of them as are corporations
have caused their corporate seals to be affixed hereunto and these presents to be signed by their proper officers, this
_____ day of _____, 20____.

Principal Corporate Seal

(Name of Principal)

By _____

(Must be President or
Vice President)

(Title)

Surety Corporate Seal

(Name of Surety)

Attorney-in-Fact

**IMPORTANT – Surety executing bonds must be licensed in West Virginia to transact surety insurance. Raised corporate seals
must be affixed, a power of attorney must be attached.**

BID BOND PREPARATION INSTRUCTIONS

AGENCY (A)
RFQ/RFP# (B)

Bid Bond

- (A) WV State Agency (Stated on Page 1 "Spending Unit") Request for Quotation Number (upper right corner of page #1)
(C) Your Company Name
(D) City, Location of your Company
(E) State, Location of your Company
(F) Surety Corporate Name
(G) City, Location of Surety
(H) State, Location of Surety
(I) State of Surety Incorporation
(J) City of Surety Incorporation
(K) Minimum amount of acceptable bid bond is 5% of total bid. You may state "5% of bid" or a specific amount on this line in words.
(L) Amount of bond in figures
(M) Brief Description of scope of work
(N) Day of the month
(O) Month
(P) Year
(Q) Name of Corporation
(R) Raised Corporate Seal of Principal
(S) Signature of President or Vice President
(T) Title of person signing
(U) Raised Corporate Seal of Surety
(V) Corporate Name of Surety
(W) Signature of Attorney in Fact of the Surety

NOTE: Dated, Power of Attorney with Raised Surety Seal must accompany this bid bond.

KNOW ALL MEN BY THESE PRESENTS, That we, the undersigned, (C) of (D), (E) as Principal, and (F) of (G), (H), a corporation organized and existing under the laws of the State of (I) with its principal office in the City of (J), as Surety, are held and firmly bound unto The State of West Virginia, as Obligee, in the penal sum of (K) (\$ (L)) for the payment of which, well and truly to be made, we jointly and severally bind ourselves, our heirs, administrators, executors, successors and assigns.

The Condition of the above obligation is such that whereas the Principal has submitted to the Purchasing Section of the Department of Administration a certain bid or proposal, attached hereto and made a part hereof to enter into a contract in writing for (M)

NOW THEREFORE.

- (a) If said bid shall be rejected, or
(b) If said bid shall be accepted and the Principal shall enter into a contract in accordance with the bid or proposal attached hereto and shall furnish any other bonds and insurance required by the bid or proposal, and shall in all other respects perform the agreement created by the acceptance of said bid then this obligation shall be null and void, otherwise this obligation shall remain in full force and effect. It is expressly understood and agreed that the liability of the Surety for any and all claims hereunder shall, in no event, exceed the penal amount of this obligation as herein stated

The Surety for value received, hereby stipulates and agrees that the obligations of said Surety and its bond shall be in no way impaired or affected by any extension of time within which the Obligee may accept such bid: and said Surety does hereby waive notice of any such extension.

IN WITNESS WHEREOF, Principal and Surety have hereunto set their hands and seals, and such of them as are corporations have caused their corporate seals to be affixed hereto and these presents to be signed by their proper officers, this (N) day of (O), 20 (P).

Principal Corporate Seal

(R)

(U)
Surety Corporate Seal

(Q)
(Name of Principal)
By (S)
(Must be President or Vice President)
(T)
Title
(V)
(Name of Surety)
(W)
Attorney-in-Fact

IMPORTANT - Surety executing bonds must be licensed in West Virginia to transact surety insurance. Raised Corporate Seals must be affixed and a Power of Attorney must be attached.

BID BOND

KNOW ALL MEN BY THESE PRESENTS, That we, the undersigned, Lee Hartman & Sons, Inc.
of Roanoke Virginia, as Principal, and The Ohio Casualty Insurance
Company of Hamilton Ohio, a corporation organized and existing under the laws of the State of
Ohio with its principal office in the City of Hamilton, as Surety, are held and firmly bound unto the State
of West Virginia, as Obligee, in the penal sum of Five Percent of Bid Price for the payment of which,
well and truly to be made, we jointly and severally bind ourselves, our heirs, administrators, executors, successors and assigns.

The Condition of the above obligation is such that whereas the Principal has submitted to the Purchasing Section of the
Department of Administration a certain bid or proposal, attached hereto and made a part hereof, to enter into a contract in writing for
West Virginia DMV request for AV equipment for two conference rooms for Commissioner
Offices, 5705 MacCorkle Avenue, S.E., Charleston, West Virginia

NOW THEREFORE,

- (a) If said bid shall be rejected, or
- (b) If said bid shall be accepted and the Principal shall enter into a contract in accordance with the bid or proposal attached
hereto and shall furnish any other bonds and insurance required by the bid or proposal, and shall in all other respects perform the
agreement created by the acceptance of said bid, then this obligation shall be null and void, otherwise this obligation shall remain in full
force and effect. It is expressly understood and agreed that the liability of the Surety for any and all claims hereunder shall, in no event,
exceed the penal amount of this obligation as herein stated.

The Surety, for the value received, hereby stipulates and agrees that the obligations of said Surety and its bond shall be in no
way impaired or affected by any extension of the time within which the Obligee may accept such bid, and said Surety does hereby
waive notice of any such extension.

IN WITNESS WHEREOF, Principal and Surety have hereunto set their hands and seals, and such of them as are corporations
have caused their corporate seals to be affixed hereunto and these presents to be signed by their proper officers, this
13th day of May, 20 11.

Principal Corporate Seal

Lee Hartman & Sons, Inc.
(Name of Principal)
By Stephen M. Hartman
(Must be President or
Vice President)
President
(Title)

Surety Corporate Seal

The Ohio Casualty Insurance Company
(Name of Surety)
Carson B. Hamilton
Attorney-in-Fact
Carson B. Hamilton
WV License #550024

**IMPORTANT - Surety executing bonds must be licensed in West Virginia to transact surety insurance. Raised corporate seals
must be affixed, a power of attorney must be attached.**

THIS POWER OF ATTORNEY IS NOT VALID UNLESS IT IS PRINTED ON RED BACKGROUND.

CERTIFIED COPY OF POWER OF ATTORNEY
**THE OHIO CASUALTY INSURANCE COMPANY
WEST AMERICAN INSURANCE COMPANY**

No. 43-928

Know All Men by These Presents: That THE OHIO CASUALTY INSURANCE COMPANY, an Ohio Corporation, and WEST AMERICAN INSURANCE COMPANY, an Indiana Corporation, pursuant to the authority granted by Article III, Section 9 of the Code of Regulations and By-Laws of The Ohio Casualty Insurance Company and West American Insurance Company, do hereby nominate, constitute and appoint: **Carson B. Hamilton, Robert D. Lowery, Elizabeth S. Mabrey, Sandra P. Hamilton or Stephen T. Hamilton of Roanoke, Virginia** its true and lawful agent (s) and attorney (s)-in-fact, to make, execute, seal and deliver for and on its behalf as surety, and as its act and deed any and all BONDS, UNDERTAKINGS, and RECOGNIZANCES, not exceeding in any single instance **TEN MILLION (\$10,000,000.00) DOLLARS**, excluding, however, any bond(s) or undertaking(s) guaranteeing the payment of notes and interest thereon.

And the execution of such bonds or undertakings in pursuance of these presents, shall be as binding upon said Companies, as fully and amply, to all intents and purposes, as if they had been duly executed and acknowledged by the regularly elected officers of the Companies at their administrative offices in Fairfield, Ohio, in their own proper persons.

The authority granted hereunder supersedes any previous authority heretofore granted the above named attorney(s)-in-fact.

In WITNESS WHEREOF, the undersigned officer of the said The Ohio Casualty Insurance Company and West American Insurance Company has hereunto subscribed his name and affixed the Corporate Seal of each Company this 9th day of December, 2010.



J. Timothy D'Errico, Assistant Secretary

STATE OF OHIO,
COUNTY OF BUTLER

On this 9th day of December, 2010 before the subscriber, a Notary Public of the State of Ohio, in and for the County of Butler, duly commissioned and qualified, came **J. Timothy D'Errico, Assistant Secretary** of THE OHIO CASUALTY INSURANCE COMPANY and WEST AMERICAN INSURANCE COMPANY, to me personally known to be the individual and officer described in, and who executed the preceding instrument, and he acknowledged the execution of the same, and being by me duly sworn deposes and says that he is the officer of the Companies aforesaid, and that the seals affixed to the preceding instrument are the Corporate Seals of said Companies, and the said Corporate Seals and his signature as officer were duly affixed and subscribed to the said instrument by the authority and direction of the said Corporations.

IN TESTIMONY WHEREOF, I have hereunto set my hand and affixed my Official Seal at the City of Hamilton, State of Ohio, the day and year first above written.



Notary Public in and for County of Butler, State of Ohio
My Commission expires August 17, 2013.

This power of attorney is granted under and by authority of Article III, Section 9 of the Code of Regulations and By-Laws of The Ohio Casualty Insurance Company and West American Insurance Company, extracts from which read:

Article III, Section 9. Appointment of Attorneys-in-Fact. The Chairman of the Board, the President, any Vice-President, the Secretary or any Assistant Secretary of the corporation shall be and is hereby vested with full power and authority to appoint attorneys-in-fact for the purpose of signing the name of the corporation as surety to, and to execute, attach the seal of the corporation to, acknowledge and deliver any and all bonds, recognizances, stipulations, undertakings or other instruments of suretyship and policies of insurance to be given in favor of any individual, firm, corporation, partnership, limited liability company or other entity, or the official representative thereof, or to any county or state, or any official board or boards of any county or state, or the United States of America or any agency thereof, or to any other political subdivision thereof.

This instrument is signed and sealed as authorized by the following resolution adopted by the Boards of Directors of the Companies on October 21, 2004:

RESOLVED, That the signature of any officer of the Company authorized under Article III, Section 9 of its Code of Regulations and By-laws and the Company seal may be affixed by facsimile to any power of attorney or copy thereof issued on behalf of the Company to make, execute, seal and deliver for and on its behalf as surety any and all bonds, undertakings or other written obligations in the nature thereof, to prescribe their respective duties and the respective limits of their authority; and to revoke any such appointment. Such signatures and seal are hereby adopted by the Company as original signatures and seal and shall, with respect to any bond, undertaking or other written obligations in the nature thereof to which it is attached, be valid and binding upon the Company with the same force and effect as though manually affixed.

CERTIFICATE

I, the undersigned Assistant Secretary of The Ohio Casualty Insurance Company and West American Insurance Company, do hereby certify that the foregoing power of attorney, the referenced By-Laws of the Companies and the above resolution of their Boards of Directors are true and correct copies and are in full force and effect on this date.

In WITNESS WHEREOF, I have hereunto set my hand and the seals of the Companies this 13th day of May, 2011.



Assistant Secretary

Not valid for mortgage, note, loan, letter of credit, bank deposit, currency rate, interest rate or residual value guarantees.

To confirm the validity of this Power of Attorney call 1-513-867-3671 between 9:00 am and 4:30 pm EST on any business day.



State of West Virginia
DRUG FREE WORKPLACE CONFORMANCE AFFIDAVIT
West Virginia Code §21-1D-5

STATE OF West Virginia

COUNTY OF Kanawha, TO-WIT:

I, Larry T. Cox, after being first duly sworn, depose and state as follows:

- 1. I am an employee of Lee Hartman & Sons, Inc.; and,
(Company Name)
- 2. I do hereby attest that Lee Hartman & Sons, Inc.
(Company Name)

maintains a valid written drug free workplace policy and that such policy is in compliance with **West Virginia Code §21-1D-5**.

The above statements are sworn to under the penalty of perjury.

Lee Hartman & Sons, Inc.
(Company Name)

By: Larry T. Cox
Title: Area Manager
Date: 5-17-2011

Taken, subscribed and sworn to before me this 17 day of May, 2011

By Commission expires July 11, 2013

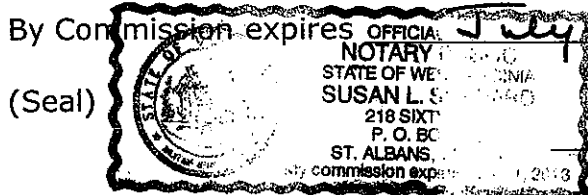

Susan L. Shepard
(Notary Public)

THIS AFFIDAVIT MUST BE SUBMITTED WITH THE BID IN ORDER TO COMPLY WITH WV CODE PROVISIONS. FAILURE TO INCLUDE THE AFFIDAVIT WITH THE BID SHALL RESULT IN DISQUALIFICATION OF THE BID.

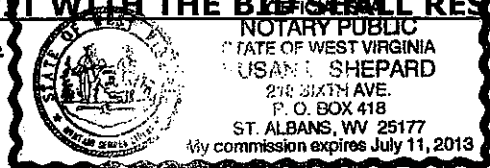

STATE OF WEST VIRGINIA
Purchasing Division

PURCHASING AFFIDAVIT

West Virginia Code §5A-3-10a states: No contract or renewal of any contract may be awarded by the state or any of its political subdivisions to any vendor or prospective vendor when the vendor or prospective vendor or a related party to the vendor or prospective vendor is a debtor and the debt owed is an amount greater than one thousand dollars in the aggregate.

DEFINITIONS:

"Debt" means any assessment, premium, penalty, fine, tax or other amount of money owed to the state or any of its political subdivisions because of a judgment, fine, permit violation, license assessment, defaulted workers' compensation premium, penalty or other assessment presently delinquent or due and required to be paid to the state or any of its political subdivisions, including any interest or additional penalties accrued thereon.

"Debtor" means any individual, corporation, partnership, association, limited liability company or any other form or business association owing a debt to the state or any of its political subdivisions. "Political subdivision" means any county commission; municipality; county board of education; any instrumentality established by a county or municipality; any separate corporation or instrumentality established by one or more counties or municipalities, as permitted by law; or any public body charged by law with the performance of a government function or whose jurisdiction is coextensive with one or more counties or municipalities. "Related party" means a party, whether an individual, corporation, partnership, association, limited liability company or any other form or business association or other entity whatsoever, related to any vendor by blood, marriage, ownership or contract through which the party has a relationship of ownership or other interest with the vendor so that the party will actually or by effect receive or control a portion of the benefit, profit or other consideration from performance of a vendor contract with the party receiving an amount that meets or exceed five percent of the total contract amount.

EXCEPTION: The prohibition of this section does not apply where a vendor has contested any tax administered pursuant to chapter eleven of this code, workers' compensation premium, permit fee or environmental fee or assessment and the matter has not become final or where the vendor has entered into a payment plan or agreement and the vendor is not in default of any of the provisions of such plan or agreement.

Under penalty of law for false swearing (*West Virginia Code §61-5-3*), it is hereby certified that the vendor affirms and acknowledges the information in this affidavit and is in compliance with the requirements as stated.

WITNESS THE FOLLOWING SIGNATURE

Vendor's Name: Lee Hartman & Sons, Inc.

Authorized Signature: *Larry T. Cox* Date: 5-17-2011

State of WV

County of Kanawha, to-wit:

Taken, subscribed, and sworn to before me this 17 day of May, 2011.

My Commission expires July 11, 2013.

AFFIX SEAL HERE

NOTARY PUBLIC *Susan L. Shepard*

