



State of West Virginia
 Department of Administration
 Purchasing Division
 2019 Washington Street East
 Post Office Box 50130
 Charleston, WV 25305-0130

Request for Quotation

RFQ NUMBER
 COR61459

PAGE
 1

ADDRESS CORRESPONDENCE TO ATTENTION OF
 TARA LYLE
 304-558-2544

PROPERTY

RFQ COPY
 TYPE NAME/ADDRESS HERE

Harris Brothers Roofing & Sheet Metal Co.
 1533 Hansford Street
 Charleston, WV 25311

SHIP TO

HUTTONSVILLE CORRECTIONAL
 CENTER
 ATTENTION: KEN HOLBROOK
 ROUTE 250 SOUTH
 HUTTONSVILLE, WV
 26273 335-2291

DATE PRINTED	TERMS OF SALE	SHIP VIA	F.O.B.	FREIGHT TERMS
10/13/2010				

BID OPENING DATE: 10/28/2010 BID OPENING TIME: 01:30PM

LINE	QUANTITY	UOP	CAT NO	ITEM NUMBER	UNIT PRICE	AMOUNT
0001	1	JB		936-75	SEE BID FORM	
<p>THERE WILL BE A PRE-BID MEETING ON 10/19/2010 AT 10:00 AM AT THE HUTTONSVILLE CORRECTIONAL CENTER. IF YOU PLAN TO ATTEND, PLEASE CONTACT LANCE YARDLEY OR BOB ARMENTROUT AT 304-335-2291 TO REGISTER PRIOR TO THE MEETING.</p> <p>*****</p> <p>PLEASE NOTE THE DRUG FREE WORKPLACE AFFIDAVIT AND BID BOND ARE REQUIRED WITH BID SUBMISSION.</p> <p>*****</p> <p>WRITTEN INQUIRIES SHALL BE ACCEPTED THROUGH CLOSE OF BUSINESS ON OCTOBER 21, 2010. QUESTIONS MAY BE SENT VIA USPS, FAX, COURIER OR EMAIL. IN ORDER TO ASSURE NO VENDOR RECEIVES AN UNFAIR ADVANTAGE, NO SUBSTANTIVE QUESTIONS WILL BE ANSWERED ORALLY. IF POSSIBLE, E-MAIL QUESTIONS ARE PREFERRED. ADDRESS INQUIRIES TO:</p> <p>TARA LYLE DEPARTMENT OF ADMINISTRATION PURCHASING DIVISION 2019 WASHINGTON STREET, EAST CHARLESTON, WV 25311</p> <p>FAX: 304-558-4115 E-MAIL: TARA.L.LYLE@WV.GOV</p>						

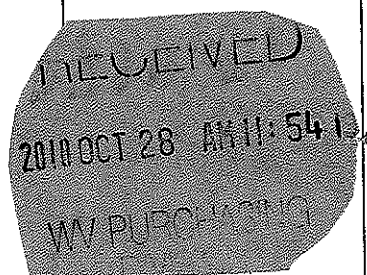

SEE REVERSE SIDE FOR TERMS AND CONDITIONS		
SIGNATURE <i>Grey Herwin</i>	TELEPHONE 304-343-5566	DATE 10/28/2010
TITLE Vice President	FEIN 550365966	ADDRESS CHANGES TO BE NOTED ABOVE

WHEN RESPONDING TO RFQ, INSERT NAME AND ADDRESS IN SPACE ABOVE LABELED 'VENDOR'

GENERAL TERMS & CONDITIONS REQUEST FOR QUOTATION (RFQ) AND REQUEST FOR PROPOSAL (RFP)

1. Awards will be made in the best interest of the State of West Virginia.
2. The State may accept or reject in part, or in whole, any bid.
3. Prior to any award, the apparent successful vendor must be properly registered with the Purchasing Division and have paid the required \$125 fee.
4. All services performed or goods delivered under State Purchase Order/Contracts are to be continued for the term of the Purchase Order/Contracts, contingent upon funds being appropriated by the Legislature or otherwise being made available. In the event funds are not appropriated or otherwise available for these services or goods this Purchase Order/Contract becomes void and of no effect after June 30.
5. Payment may only be made after the delivery and acceptance of goods or services.
6. Interest may be paid for late payment in accordance with the *West Virginia Code*.
7. Vendor preference will be granted upon written request in accordance with the *West Virginia Code*.
8. The State of West Virginia is exempt from federal and state taxes and will not pay or reimburse such taxes.
9. The Director of Purchasing may cancel any Purchase Order/Contract upon 30 days written notice to the seller.
10. The laws of the State of West Virginia and the *Legislative Rules* of the Purchasing Division shall govern the purchasing process.
11. Any reference to automatic renewal is hereby deleted. The Contract may be renewed only upon mutual written agreement of the parties.
12. **BANKRUPTCY:** In the event the vendor/contractor files for bankruptcy protection, the State may deem this contract null and void, and terminate such contract without further order.
13. **HIPAA BUSINESS ASSOCIATE ADDENDUM:** The West Virginia State Government HIPAA Business Associate Addendum (BAA), approved by the Attorney General, is available online at www.state.wv.us/admin/purchase/vrc/hipaa.htm and is hereby made part of the agreement. Provided that the Agency meets the definition of a Cover Entity (45 CFR §160.103) and will be disclosing Protected Health Information (45 CFR §160.103) to the vendor.
14. **CONFIDENTIALITY:** The vendor agrees that he or she will not disclose to anyone, directly or indirectly, any such personally identifiable information or other confidential information gained from the agency, unless the individual who is the subject of the information consents to the disclosure in writing or the disclosure is made pursuant to the agency's policies, procedures, and rules. Vendor further agrees to comply with the Confidentiality Policies and Information Security Accountability Requirements, set forth in <http://www.state.wv.us/admin/purchase/privacy/noticeConfidentiality.pdf>.
15. **LICENSING:** Vendors must be licensed and in good standing in accordance with any and all state and local laws and requirements by any state or local agency of West Virginia, including, but not limited to, the West Virginia Secretary of State's Office, the West Virginia Tax Department, and the West Virginia Insurance Commission. The vendor must provide all necessary releases to obtain information to enable the director or spending unit to verify that the vendor is licensed and in good standing with the above entities.
16. **ANTITRUST:** In submitting a bid to any agency for the State of West Virginia, the bidder offers and agrees that if the bid is accepted the bidder will convey, sell, assign or transfer to the State of West Virginia all rights, title and interest in and to all causes of action it may now or hereafter acquire under the antitrust laws of the United States and the State of West Virginia for price fixing and/or unreasonable restraints of trade relating to the particular commodities or services purchased or acquired by the State of West Virginia. Such assignment shall be made and become effective at the time the purchasing agency tenders the initial payment to the bidder.

I certify that this bid is made without prior understanding, agreement, or connection with any corporation, firm, limited liability company, partnership, or person or entity submitting a bid for the same material, supplies, equipment or services and is in all respects fair and without collusion or fraud. I further certify that I am authorized to sign the certification on behalf of the bidder or this bid.

INSTRUCTIONS TO BIDDERS

1. Use the quotation forms provided by the Purchasing Division. Complete all sections of the quotation form.
2. Items offered must be in compliance with the specifications. Any deviation from the specifications must be clearly indicated by the bidder. Alternates offered by the bidder as **EQUAL** to the specifications must be clearly defined. A bidder offering an alternate should attach complete specifications and literature to the bid. The Purchasing Division may waive minor deviations to specifications.
3. Unit prices shall prevail in case of discrepancy. All quotations are considered F.O.B. destination unless alternate shipping terms are clearly identified in the quotation.
4. All quotations must be delivered by the bidder to the office listed below prior to the date and time of the bid opening. Failure of the bidder to deliver the quotations on time will result in bid disqualifications: Department of Administration, Purchasing Division, 2019 Washington Street East, P.O. Box 50130, Charleston, WV 25305-0130
5. Communication during the solicitation, bid, evaluation or award periods, except through the Purchasing Division, is strictly prohibited (W.Va. C.S.R. §148-1-6.6).



State of West Virginia
 Department of Administration
 Purchasing Division
 2019 Washington Street East
 Post Office Box 50130
 Charleston, WV 25305-0130

Request for Quotation

RFO NUMBER
 COR61459

PAGE
 2

ADDRESS CORRESPONDENCE TO ATTENTION OF
 TARA LYLE
 304-558-2544

HUTTONSVILLE CORRECTIONAL
 CENTER
 ATTENTION: KEN HOLBROOK
 ROUTE 250 SOUTH
 HUTTONSVILLE, WV
 26273 335-2291

VENDOR

RFQ COPY

TYPE NAME/ADDRESS HERE

Harris Brothers Roofing & Sheet Metal Co.
 1533 Hansford Street
 Charleston, WV 25311

SHIP TO

DATE PRINTED	TERMS OF SALE	SHIP VIA	FOB	FREIGHT TERMS
10/13/2010				

BID OPENING DATE: 10/28/2010

LINE	QUANTITY	UOP	CAT NO	ITEM NUMBER	BID OPENING TIME	UNIT PRICE	AMOUNT
					01:30PM		

THE MODEL/BRAND/SPECIFICATIONS NAMED HEREIN ESTABLISH THE ACCEPTABLE LEVEL OF QUALITY ONLY AND ARE NOT INTENDED TO REFLECT A PREFERENCE OR FAVOR ANY PARTICULAR BRAND OR VENDOR. VENDORS WHO ARE BIDDING ALTERNATES SHOULD SO STATE AND INCLUDE PERTINENT LITERATURE AND SPECIFICATIONS. FAILURE TO PROVIDE INFORMATION FOR ANY ALTERNATES MAY BE GROUNDS FOR REJECTION OF THE BID. THE STATE RESERVES THE RIGHT TO WAIVE MINOR IRREGULARITIES IN BIDS OR SPECIFICATIONS IN ACCORDANCE WITH SECTION 148-1-4(F) OF THE WEST VIRGINIA LEGISLATIVE RULES AND REGULATIONS.

EXHIBIT 5

WEST VIRGINIA CODE 21-1D-5 PROVIDES THAT: ANY SOLICITATION FOR A PUBLIC IMPROVEMENT CONSTRUCTION CONTRACT REQUIRES EACH VENDOR THAT SUBMITS A BID FOR THE WORK TO SUBMIT AT THE SAME TIME AN AFFIDAVIT OF COMPLIANCE WITH THE BID. THE ENCLOSED DRUG-FREE WORKPLACE AFFIDAVIT MUST BE SIGNED AND SUBMITTED WITH THE BID AS EVIDENCE OF THE VENDOR'S COMPLIANCE WITH THE PROVISIONS OF ARTICLE 1D, CHAPTER 21 OF THE WEST VIRGINIA CODE. FAILURE TO SUBMIT THE SIGNED DRUG-FREE WORKPLACE AFFIDAVIT WITH THE BID SHALL RESULT IN DISQUALIFICATION OF SUCH BID.

NOTICE TO PROCEED: THIS CONTRACT IS TO BE PERFORMED WITHIN 30 CALENDAR DAYS AFTER THE NOTICE TO PROCEED IS RECEIVED. UNLESS OTHERWISE SPECIFIED, THE FULLY EXECUTED PURCHASE ORDER WILL BE CONSIDERED NOTICE TO PROCEED.

CANCELLATION: THE DIRECTOR OF PURCHASING RESERVES THE RIGHT TO CANCEL THIS CONTRACT IMMEDIATELY UPON WRITTEN NOTICE TO THE VENDOR IF THE MATERIALS OR WORKMANSHIP SUPPLIED ARE OF AN INFERIOR QUALITY OR DO NOT CONFORM

SEE REVERSE SIDE FOR TERMS AND CONDITIONS

SIGNATURE <i>Amy Harris</i>	TELEPHONE 304-343-5566	DATE 10/28/2010
TITLE Vice President	FEIN 550365966	ADDRESS CHANGES TO BE NOTED ABOVE

WHEN RESPONDING TO RFQ, INSERT NAME AND ADDRESS IN SPACE ABOVE LABELED 'VENDOR'



State of West Virginia
 Department of Administration
 Purchasing Division
 2019 Washington Street East
 Post Office Box 50130
 Charleston, WV 25305-0130

**Request for
 Quotation**

RFQ NUMBER
 COR61459

PAGE
 3

ADDRESS CORRESPONDENCE TO ATTENTION OF
 TARA LYLE
 304-558-2544

RFQ COPY

TYPE NAME/ADDRESS HERE

VENDOR

Harris Brothers Roofing & Sheet Metal Co.
 1533 Hansford Street
 Charleston, WV 25311

SHIP TO

HUTTONSVILLE CORRECTIONAL
 CENTER
 ATTENTION: KEN HOLBROOK
 ROUTE 250 SOUTH
 HUTTONSVILLE, WV
 26273 335-2291

DATE PRINTED	TERMS OF SALE	SHIP VIA	FOB	FREIGHT TERMS
10/13/2010				

BID OPENING DATE: 10/28/2010 BID OPENING TIME: 01:30PM

LINE	QUANTITY	UOP	CAT NO	ITEM NUMBER	UNIT PRICE	AMOUNT
<p>WITH THE SPECIFICATIONS OF THE BID AND CONTRACT HERE IN.</p> <p>WAGE RATES: THE CONTRACTOR OR SUBCONTRACTOR SHALL PAY THE HIGHER OF THE U.S. DEPARTMENT OF LABOR MINIMUM WAGE RATES AS ESTABLISHED FOR RANDOLPH COUNTY, PURSUANT TO WEST VIRGINIA CODE 21-5A, ET, SEQ. (PREVAILING WAGE RATES APPLY TO THIS PROJECT)</p> <p>ARBITRATION: ANY REFERENCES MADE TO ARBITRATION OR INTEREST FOR PAYMENTS DUE (EXCEPT FOR ANY INTEREST REQUIRED BY STATE LAW) CONTAINED IN THIS CONTRACT OR IN ANY AMERICAN INSTITUTE OF ARCHITECTS DOCUMENTS PERTAINING TO THIS CONTRACT ARE HEREBY DELETED.</p> <p>WORKERS' COMPENSATION: VENDOR IS REQUIRED TO PROVIDE A CERTIFICATE FROM WORKERS' COMPENSATION IF SUCCESSFUL.</p> <p>ALL OF THE ITEMS CHECKED BELOW WILL BE A REQUIREMENT OF THIS CONTRACT:</p> <p>(XX) INSURANCE: SUCCESSFUL VENDOR SHALL FURNISH PROOF OF COMMERCIAL GENERAL LIABILITY INSURANCE PRIOR TO ISSUANCE OF CONTRACT. UNLESS OTHERWISE SPECIFIED IN THE BID DOCUMENTS, THE MINIMUM AMOUNT OF INSURANCE COVERAGE REQUIRED IS \$250,000.</p> <p>() BUILDERS RISK INSURANCE: SUCCESSFUL VENDOR SHALL FURNISH PROOF OF BUILDERS RISK - ALL RISK INSURANCE IN AN AMOUNT EQUAL TO 100% OF THE AMOUNT OF THE CONTRACT.</p> <p>(XX) BONDS: FIVE PERCENT (5%) OF THE TOTAL AMOUNT OF THE BID PAYABLE TO THE STATE OF WEST VIRGINIA, SHALL BE SUBMITTED WITH EACH BID AS A BID BOND. THE SUCCESSFUL BIDDER SHALL ALSO FURNISH A PERFORMANCE BOND AND LABOR/MATERIAL BOND FOR 100% OF THE AMOUNT OF THE CONTRACT</p>						

SEE REVERSE SIDE FOR TERMS AND CONDITIONS

SIGNATURE: *Grey Harris* TELEPHONE: 304-343-5566 DATE: 10/28/2010

TITLE: Vice President FEIN: 550365966 ADDRESS CHANGES TO BE NOTED ABOVE

WHEN RESPONDING TO RFQ, INSERT NAME AND ADDRESS IN SPACE ABOVE LABELED 'VENDOR'



State of West Virginia
 Department of Administration
 Purchasing Division
 2019 Washington Street East
 Post Office Box 50130
 Charleston, WV 25305-0130

Request for Quotation

RFQ NUMBER
COR61459

PAGE
4

ADDRESS CORRESPONDENCE TO ATTENTION OF
TARA LYLE 304-558-2544

RFQ COPY
 TYPE NAME/ADDRESS HERE

VENDOR
 Harris Brothers Roofing & Sheet Metal Co.
 1533 Hansford Street
 Charleston, WV 25311

SHIP TO
 HUTTONSVILLE CORRECTIONAL
 CENTER
 ATTENTION: KEN HOLBROOK
 ROUTE 250 SOUTH
 HUTTONSVILLE, WV
 26273 335-2291

DATE PRINTED	TERMS OF SALE	SHIP VIA	FOB	FREIGHT TERMS
10/13/2010				

BID OPENING DATE: 10/28/2010 BID OPENING TIME 01:30PM

LINE	QUANTITY	UOP	CAT NO	ITEM NUMBER	UNIT PRICE	AMOUNT
<p>BONDS MAY BE PROVIDED IN THE FORM OF A CERTIFIED CHECK, IRREVOCABLE LETTER OF CREDIT, OR BOND FURNISHED BY A SOLVENT SURETY COMPANY AUTHORIZED TO DO BUSINESS IN THE STATE OF WEST VIRGINIA. A LETTER OF CREDIT SUBMITTED IN LIEU OF A BOND WILL ONLY BE ALLOWED FOR PROJECTS UNDER \$100,000. PERSONAL OR BUSINESS CHECKS ARE NOT ACCEPCTABLE IN LIEU OF THE 5% BID BOND, PERFORMANCE BOND, OR LABOR AND MATERIAL BOND.</p> <p>() MAINTENANCE BOND: A TWO (2) YEAR MAINTENANCE BOND COVERING THE ROOFING SYSTEM WILL BE A REQUIREMENT OF THE SUCCESSFUL VENDOR.</p> <p>REV. 11/00</p> <p>EXHIBIT 7</p> <p>DOMESTIC ALUMINUM, GLASS & STEEL IN PUBLIC WORKS PROJECTS</p> <p>IN ACCORDANCE WITH WEST VIRGINIA CODE 5-19-1 ET., SEQ., EVERY CONTRACT FOR CONSTRUCTION, RECONSTRUCTION, ALTERATION, REPAIR, IMPROVEMENT OR MAINTENANCE OF PUBLIC WORKS, WHERE THE COST IS MORE THAN \$50,000 AND, IN THE CASE OF STEEL ONLY, WHERE THE COST OF STEEL IS MORE THAN \$50,000 OR WHERE MORE THAN 10,000 POUNDS OF STEEL ARE REQUIRED, THE STATE WILL ACCEPT ONLY ALUMINUM GLASS, OR STEEL PRODUCTS PRODUCED IN THE UNITED STATES. IN ADDITION, ITEMS OF MACHINERY OR EQUIPMENT PURCHASED FOR USE AT THE SITE OF PUBLIC WORKS SHALL BE MADE OF DOMESTIC ALUMINUM, GLASS OR STEEL, UNLESS THE COST OF THE PRODUCT IS LESS THAN \$50,000 OR LESS THAN 10,000 POUNDS OF STEEL ARE USED IN PUBLIC WORKS PROJECTS.</p> <p>FOREIGN MADE ALUMINUM, GLASS OR STEEL PRODUCTS MAY BE</p>						

SEE REVERSE SIDE FOR TERMS AND CONDITIONS

SIGNATURE	TELEPHONE	DATE
<i>Grey Harris</i>	304-343-5566	10/28/2010
TITLE	FEIN	ADDRESS CHANGES TO BE NOTED ABOVE
Vice President	550365966	

WHEN RESPONDING TO RFQ, INSERT NAME AND ADDRESS IN SPACE ABOVE LABELED 'VENDOR'



State of West Virginia
 Department of Administration
 Purchasing Division
 2019 Washington Street East
 Post Office Box 50130
 Charleston, WV 25305-0130

Request for Quotation

RFQ NUMBER
COR61459

PAGE
5

ADDRESS CORRESPONDENCE TO ATTENTION OF
TARA LYLE 304-558-2544

RFQ COPY

TYPE NAME/ADDRESS HERE

VENDOR

Harris Brothers Roofing & Sheet Metal Co.
 1533 Hansford Street
 Charleston, WV 25311

SHIP TO

HUTTONSVILLE CORRECTIONAL CENTER
 ATTENTION: KEN HOLBROOK
 ROUTE 250 SOUTH
 HUTTONSVILLE, WV 26273 335-2291

DATE PRINTED	TERMS OF SALE	SHIP VIA	FOB	FREIGHT TERMS
10/13/2010				

BID OPENING DATE: 10/28/2010 BID OPENING TIME 01:30PM

LINE	QUANTITY	UOP	CAT NO	ITEM NUMBER	UNIT PRICE	AMOUNT
<p>ACCEPTED ONLY IF THE COST OF DOMESTIC PRODUCTS IS FOUND TO BE UNREASONABLE. SUCH COST IS UNREASONABLE IF IT IS 20% OR MORE HIGHER THAN THE BID PRICE FOR FOREIGN MADE PRODUCTS. IF THE DOMESTIC ALUMINUM, GLASS OR STEEL PRODUCTS TO BE SUPPLIED OR PRODUCED IN A "SUBSTANTIAL LABOR SURPLUS AREA", AS DEFINED BY THE UNITED STATES DEPARTMENT OF LABOR, FOREIGN PRODUCTS MAY BE SUPPLIED ONLY IF DOMESTIC PRODUCTS ARE 30% OR MORE HIGHER IN PRICE THAN THE FOREIGN MADE PRODUCTS.</p> <p>IF, PRIOR TO THE AWARD OF A CONTRACT UNDER THE ABOVE PROVISIONS, THE SPENDING OFFICER OF THE SPENDING UNIT DETERMINES THAT THERE EXISTS A BID FOR LIKE FOREIGN ALUMINUM, GLASS OR STEEL THAT IS REASONABLE AND LOWER THAN THE LOWEST BID DOMESTIC PRODUCTS, THE SPENDING OFFICE MAY REQUEST, IN WRITING, A REEVALUATION AND REDUCTION IN THE LOWEST BID FOR SUCH DOMESTIC PRODUCTS. ALL VENDORS MUST INDICATE IN THEIR BID IF THEY ARE SUPPLYING FOREIGN ALUMINUM, GLASS OR STEEL.</p> <p>REV. 3/88</p> <p>EXHIBIT 9</p> <p>NOTICE FOR ISSUANCE & ACKNOWLEDGEMENT OF CONSTRUCTION PROJECT ADDENDA</p> <p>THE ARCHITECT/ENGINEER AND/OR AGENCY SHALL BE REQUIRED TO ABIDE BY THE FOLLOWING SCHEDULE IN ISSUING CONSTRUCTION PROJECT ADDENDA FOR STATE AGENCIES:</p> <p>(1) THE ARCHITECT/ENGINEER SHALL PREPARE THE ADDENDUM AND A LIST OF ALL PARTIES THAT HAVE PROCURED DRAWINGS AND SPECIFICATIONS FOR THE PROJECT. THE ADDENDUM AND LIST SHALL BE FORWARDED TO THE BUYER IN THE STATE</p>						

SIGNATURE		TELEPHONE		DATE
<i>Gay Harris</i>		304-343-5566		10/28/2010
TITLE	FEIN	ADDRESS CHANGES TO BE NOTED ABOVE		
Vice President	550365966			

WHEN RESPONDING TO RFQ, INSERT NAME AND ADDRESS IN SPACE ABOVE LABELED 'VENDOR'



State of West Virginia
 Department of Administration
 Purchasing Division
 2019 Washington Street East
 Post Office Box 50130
 Charleston, WV 25305-0130

Request for Quotation

RFQ NUMBER:
 COR61459

PAGE
 6

ADDRESS CORRESPONDENCE TO ATTENTION OF
 TARA LYLE
 304-558-2544

VENDOR

RFQ COPY

TYPE NAME/ADDRESS HERE

Harris Brothers Roofing & Sheet Metal Co.
 1533 Hansford Street
 Charleston, WV 25311

SHIP TO

HUTTONSVILLE CORRECTIONAL
 CENTER
 ATTENTION: KEN HOLBROOK
 ROUTE 250 SOUTH
 HUTTONSVILLE, WV
 26273 335-2291

DATE PRINTED	TERMS OF SALE	SHIP VIA	FOB	FREIGHT TERMS
10/13/2010				

BID OPENING DATE: 10/28/2010 BID OPENING TIME 01:30PM

LINE	QUANTITY	UOP	CAT NO	ITEM NUMBER	UNIT PRICE	AMOUNT
<p>PURCHASING DIVISION. THE ARCHITECT/ENGINEER SHALL ALSO SEND A COPY OF THE ADDENDUM TO THE STATE AGENCY FOR WHICH THE CONTRACT IS ISSUED.</p> <p>(2) THE BUYER SHALL SEND THE ADDENDUM TO ALL INTERESTED PARTIES AND, IF NECESSARY, EXTEND THE BID OPENING DATE. ANY ADDENDUM SHOULD BE RECEIVED BY THE BUYER WITHIN FOURTEEN (14) DAYS PRIOR TO THE BID OPENING DATE.</p> <p>(3) ALL ADDENDA SHOULD BE FORMALLY ACKNOWLEDGED BY ALL BIDDERS AND SUBMITTED TO THE STATE PURCHASING DIVISION. THE SAME RULES AND REGULATIONS THAT APPLY TO THE ORIGINAL BIDDING DOCUMENT SHALL ALSO APPLY TO AN ADDENDUM DOCUMENT. THE ONLY EXCEPTION MAY BE FOR AN ADDENDUM THAT IS ISSUED FOR THE SOLE PURPOSE OF CHANGING A BID OPENING TIME AND/OR DATE.</p> <p>REV. 11/96</p> <p>EXHIBIT 10</p> <p>ADDENDUM ACKNOWLEDGEMENT</p> <p>I HEREBY ACKNOWLEDGE RECEIPT OF THE FOLLOWING CHECKED ADDENDUM(S) AND HAVE MADE THE NECESSARY REVISIONS TO MY PROPOSAL, PLANS AND/OR SPECIFICATION, ETC.</p> <p>ADDENDUM NOS.:</p> <p>NO. 1 X received KH</p> <p>NO. 2</p>						

SEE REVERSE SIDE FOR TERMS AND CONDITIONS

SIGNATURE <i>Grey Harris</i>	TELEPHONE 304-343-5566	DATE 10/28/2010
TITLE Vice President	FEIN 550365966	ADDRESS CHANGES TO BE NOTED ABOVE

WHEN RESPONDING TO RFQ, INSERT NAME AND ADDRESS IN SPACE ABOVE LABELED 'VENDOR'



State of West Virginia
 Department of Administration
 Purchasing Division
 2019 Washington Street East
 Post Office Box 50130
 Charleston, WV 25305-0130

Request for Quotation

RFQ NUMBER
 COR61459

PAGE
 7

ADDRESS CORRESPONDENCE TO ATTENTION OF
 TARA LYLE
 304 558 2544

S U B J E C T

RFQ COPY
 TYPE NAME/ADDRESS HERE

Harris Brothers Roofing & Sheet Metal Co.
 1533 Hansford Street
 Charleston, WV 25311

S H I P T O

HUTTONSVILLE CORRECTIONAL
 CENTER
 ATTENTION: KEN HOLBROOK
 ROUTE 250 SOUTH
 HUTTONSVILLE, WV
 26273 335-2291

DATE PRINTED	TERMS OF SALE	SHIP VIA	F.O.B.	FREIGHT TERMS
10/13/2010				

BID OPENING DATE: 10/28/2010 BID OPENING TIME: 01:30PM

LINE	QUANTITY	UOP	CAT NO	ITEM NUMBER	UNIT PRICE	AMOUNT
NO. 3						
NO. 4						
NO. 5						
<p>I UNDERSTAND THAT FAILURE TO CONFIRM THE RECEIPT OF THE ADDENDUM(S) MAY BE CAUSE FOR REJECTION OF THE BIDS.</p> <p>VENDOR MUST CLEARLY UNDERSTAND THAT ANY VERBAL REPRESENTATION MADE OR ASSUMED TO BE MADE DURING ANY ORAL DISCUSSION HELD BETWEEN VENDOR'S REPRESENTATIVES AND ANY STATE PERSONNEL IS NOT BINDING. ONLY THE INFORMATION ISSUED IN WRITING AND ADDED TO THE SPECIFICATIONS BY AN OFFICIAL ADDENDUM IS BINDING.</p> <p>..... <i>Grey Harris</i> SIGNATURE</p> <p>Harris Brothers Roofing & Sheet Metal Co. COMPANY</p> <p>10/28/2010 DATE</p> <p>REV. 11/96</p> <p>CONTRACTORS LICENSE</p> <p>WEST VIRGINIA STATE CODE 21-11-2 REQUIRES THAT ALL PERSONS DESIRING TO PERFORM CONTRACTING WORK IN THIS STATE MUST BE LICENSED. THE WEST VIRGINIA CONTRACTORS LICENSING BOARD IS EMPOWERED TO ISSUE THE CONTRACTORS LICENSE. APPLICATIONS FOR A CONTRACTORS LICENSE MAY BE MADE BY CONTACTING THE WEST VIRGINIA DIVISION OF LABOR CAPITOL COMPLEX, BUILDING 3, ROOM 319, CHARLESTON, WV 25305. TELEPHONE: (304) 558-7890.</p>						

SEE REVERSE SIDE FOR TERMS AND CONDITIONS		
SIGNATURE <i>Grey Harris</i>	TELEPHONE 304-343-5566	DATE 10/28/2010
TITLE Vice President	FEIN 550365966	ADDRESS CHANGES TO BE NOTED ABOVE

WHEN RESPONDING TO RFQ, INSERT NAME AND ADDRESS IN SPACE ABOVE LABELED 'VENDOR'



State of West Virginia
 Department of Administration
 Purchasing Division
 2019 Washington Street East
 Post Office Box 50130
 Charleston, WV 25305-0130

Request for Quotation

RFQ NUMBER
 COR61459

PAGE
 8

ADDRESS CORRESPONDENCE TO ATTENTION OF
 TARA LYLE
 304-558-2544

RFQ COPY

TYPE NAME/ADDRESS HERE

Harris Brothers Roofing & Sheet Metal Co.
 1533 Hansford Street
 Charleston, WV 25311

HUTTONSVILLE CORRECTIONAL
 CENTER
 ATTENTION: KEN HOLBROOK
 ROUTE 250 SOUTH
 HUTTONSVILLE, WV
 26273 335-2291

ROBZOK

SHIP TO

DATE PRINTED	TERMS OF SALE	SHIP VIA	F.O.B.	FREIGHT TERMS
10/13/2010				

BID OPENING DATE: 10/28/2010 BID OPENING TIME: 01:30PM

LINE	QUANTITY	UOP	CAT NO	ITEM NUMBER	UNIT PRICE	AMOUNT
<p>WEST VIRGINIA STATE CODE 21-11-11 REQUIRES ANY PROSPECTIVE BIDDER TO INCLUDE THE CONTRACTORS LICENSE NUMBER ON THEIR BID.</p> <p>BIDDER TO COMPLETE:</p> <p>CONTRACTORS NAME: Harris Brothers Roofing & Sheet Metal Company, Inc.</p> <p>CONTRACTORS LICENSE NO.: WV000232</p> <p>THE SUCCESSFUL BIDDER WILL BE REQUIRED TO FURNISH A COPY OF THEIR CONTRACTORS LICENSE PRIOR TO ISSUANCE OF A PURCHASE ORDER/CONTRACT</p> <p>APPLICABLE LAW</p> <p>THE WEST VIRGINIA STATE CODE, PURCHASING DIVISION RULE AND REGULATIONS, AND THE INFORMATION PROVIDED IN THE "REQUEST FOR QUOTATION" ISSUED BY THE PURCHASING DIVISION IS THE SOLE AUTHORITY GOVERNING THIS PROCUREMENT.</p> <p>ANY INFORMATION PROVIDED IN SPECIFICATION MANUALS, OR ANY OTHER SOURCE, VERBAL OR WRITTEN, WHICH CONTRADICTS OR ALTERS THE INFORMATION PROVIDED FROM THE SOURCES AS DESCRIBED IN THE ABOVE PARAGRAPH IS VOID AND OF NO EFFECT.</p> <p>BANKRUPTCY: IN THE EVENT THE VENDOR/CONTRACTOR FILES FOR BANKRUPTCY PROTECTION, THE STATE MAY DEEM THE CONTRACT NULL AND VOID, AND TERMINATE SUCH CONTRACT WITHOUT FURTHER ORDER.</p> <p>REV. 5/2009</p>						

SEE REVERSE SIDE FOR TERMS AND CONDITIONS

SIGNATURE <i>Grey Harris</i>	TELEPHONE 304-343-5566	DATE 10/28/2010
TITLE Vice President	FEIN 550365966	ADDRESS CHANGES TO BE NOTED ABOVE

WHEN RESPONDING TO RFQ, INSERT NAME AND ADDRESS IN SPACE ABOVE LABELED 'VENDOR'



State of West Virginia
 Department of Administration
 Purchasing Division
 2019 Washington Street East
 Post Office Box 50130
 Charleston, WV 25305-0130

Request for Quotation

RFQ NUMBER
COR61459

PAGE
9

ADDRESS CORRESPONDENCE TO ATTENTION OF
TARA LYLE 304-558-2544

VENDOR

RFQ COPY
 TYPE NAME/ADDRESS HERE

Harris Brothers Roofing & Sheet Metal Co.
 1533 Hansford Street
 Charleston, WV 25311

SHIP TO

HUTTONSVILLE CORRECTIONAL
 CENTER
 ATTENTION: KEN HOLBROOK
 ROUTE 250 SOUTH
 HUTTONSVILLE, WV
 26273 335-2291

DATE PRINTED	TERMS OF SALE	SHIP VIA	F.O.B.	FREIGHT TERMS
10/13/2010				

BID OPENING DATE: 10/28/2010 BID OPENING TIME: 01:30PM

LINE	QUANTITY	UOP	CAT NO	ITEM NUMBER	UNIT PRICE	AMOUNT
<p>NOTICE</p> <p>A SIGNED BID MUST BE SUBMITTED TO:</p> <p>DEPARTMENT OF ADMINISTRATION PURCHASING DIVISION BUILDING 15 2019 WASHINGTON STREET, EAST CHARLESTON, WV 25305-0130</p> <p>THE BID SHOULD CONTAIN THIS INFORMATION ON THE FACE OF THE ENVELOPE OR THE BID MAY NOT BE CONSIDERED:</p> <p>SEALED BID</p> <p>BUYER:-----TL/32-----</p> <p>REQ. NO.:-----COR61459-----</p> <p>BID OPENING DATE:-----10/28/2010-----</p> <p>BID OPENING TIME:-----1:30 PM-----</p> <p>PLEASE PROVIDE A FAX NUMBER IN CASE IT IS NECESSARY TO CONTACT YOU REGARDING YOUR BID:</p> <p>304-343-5568 FAX</p> <p>PLEASE PRINT OR TYPE NAME OF PERSON TO CONTACT CONCERNING THIS QUOTE:</p> <p>Grey Harris</p>						

SEE REVERSE SIDE FOR TERMS AND CONDITIONS			
SIGNATURE	TELEPHONE	DATE	
<i>Grey Harris</i>	304-343-5566	10/28/2010	
TITLE	FEIN	ADDRESS CHANGES TO BE NOTED ABOVE	
Vice President	550365966		

WHEN RESPONDING TO RFQ, INSERT NAME AND ADDRESS IN SPACE ABOVE LABELED 'VENDOR'



State of West Virginia
 Department of Administration
 Purchasing Division
 2019 Washington Street East
 Post Office Box 50130
 Charleston, WV 25305-0130

Request for Quotation

RFQ NUMBER
COR61459

PAGE
10

ADDRESS CORRESPONDENCE TO ATTENTION OF
TARA LYLE 304-558-2544

VENDOR

RFQ COPY
 TYPE NAME/ADDRESS HERE

Harris Brothers Roofing & Sheet Metal Co.
 1533 Hansford Street
 Charleston, WV 25311

SHIP TO

HUTTONSVILLE CORRECTIONAL
 CENTER
 ATTENTION: KEN HOLBROOK
 ROUTE 250 SOUTH
 HUTTONSVILLE, WV
 26273 335-2291

DATE PRINTED	TERMS OF SALE	SHIP VIA	FOB	FREIGHT TERMS
10/13/2010				

BID OPENING DATE: 10/28/2010 BID OPENING TIME: 01:30PM

LINE	QUANTITY	UOP	CAT NO	ITEM NUMBER	UNIT PRICE	AMOUNT
***** THIS IS THE END OF RFQ COR61459 ***** TOTAL: SEE BID FORM						

SEE REVERSE SIDE FOR TERMS AND CONDITIONS		
SIGNATURE <i>Grey Horn</i>	TELEPHONE 304-343-5566	DATE 10/28/2010
TITLE Vice President	FEIN 550365966	ADDRESS CHANGES TO BE NOTED ABOVE

WHEN RESPONDING TO RFQ, INSERT NAME AND ADDRESS IN SPACE ABOVE LABELED 'VENDOR'

RFQ # COR61459

**ALL LABOR MATERIALS, EQUIPMENT AND SUPPLIES NECESSARY TO
INSTALL BOILER AND CONTROLS
MAINTENANCE BUILDING
HUTTONSVILLE CORRECTIONAL CENTER
RANDOLPH COUNTY**

BID FORM

Bidder's Company Name: Harris Brothers Roofing & Sheet Metal Company, Inc.

Bidder's Address: 1533 Hansford Street
Charleston, WV 25311

Remittance Address: same as above
(if different)

Phone Number: 304-343-5566

Fax Number: 304-343-5568

Email Address: grey.harris@frontier.com

WV Contractor's License Number: WV000232

We, the undersigned, hereby propose to furnish all materials, equipment, and labor to complete all work in a workmanlike manner, as described in the Bidding Documents.

BASE BID	\$ 47,770.00
ALTERNATE- 1	\$ 700.00
ALTERNATE- 2	\$ 1,400.00
ALTERNATE - 3	\$ 500.00

TOTAL CONTRACT BID INCLUDING ALTERNATES

Fifty Thousand, Three Hundred Seventy Dollars and No Cents

(\$ 50,370.00)
(Total to be written in words and numbers.)

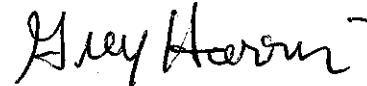

The Bidder understands that to the extent allowed by the West Virginia Code, the OWNER reserves the right to waive any informality or irregularity in any Bid, or Bids, and to reject any or all Bids in whole or in part; to reject a bid not accompanied by the required bid security or by other data required by the Bidding Documents; to reject any conditions of the bid by the Bidder that is in any way inconsistent with the requirements, terms, and conditions of the Bidding Documents; or to reject a bid that is in any way incomplete or irregular.

Smith

CAST IRON BOILERS™

A LEGEND IN HEATING
[HOME](#) [CONTACT](#) [NEWS](#) [EVENTS](#)
[PRODUCTS](#)
[SALES INFO](#)
[LITERATURE LIBRARY](#)
[ABOUT](#)
[LINKS](#)
[TECHNICALS](#)
[CASE STUDIES](#)
[SHARE](#)
[Products > Commercial Products > Series 28A](#)

28A Series Power-burner Boilers, fired with Oil, Gas or Both

Smith 28A cast iron boilers are ideal in commercial applications for steam heating systems. The market leader in large commercial cast iron boilers, 28A series boilers are available in fifteen sizes from 900 to 4,270 MBH with high efficiencies.

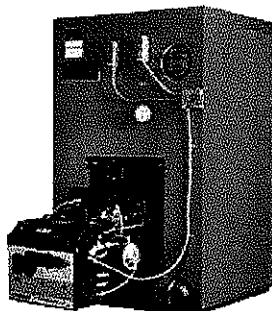

Series 28A Boiler Features

- Rugged cast iron heat exchanger sections with integral flue collector
- High temperature flexible graphite port connectors provide the installation ease of a gasket and long life of a push nipple
- Graphite port connectors and ceramic fiber flue gas rope seals reduce assembly time and require no special assembly tools
- Short, individual draw rods simplify assembly and reduce stress
- Front and rear observation ports to visually inspect the flame and combustion chamber
- Easy-to-remove, front access covers and side mounted cover plates for quick and easy boiler cleaning
- Side mounted tankless coil domestic water heaters (when provided) for easy inspection and/or replacement
- Cast iron smoke hood with integral fail-safe breeching damper that is easily adjusted and locked into position
- Obround shaped upper port for improved internal circulation and dry steam
- Factory packaged or knocked down for field assembly
- Choice of Beckett, Carlin, Powerflame and Webster power burners with a wide array of controls (when provided)

PRODUCT LITERATURE

[28a](#)
[28A Series](#)
[Series 28A](#)

STANDARD EQUIPMENT

- Cast iron wet-base sections rated for 15 psi (steam)
- ASME safety relief valve
- Hi limit, manual reset control
- Operating temperature or pressure control
- Burner mounting plate with insulation block
- Insulated metal jacket, steel floor rails and flue brush
- Steam pressure gauge
- Gauge glass and fittings

OPTIONAL EQUIPMENT

- Tankless coil domestic water heaters
- CSD-1 or FM approved fuel trains
- Inspection tappings, return yoke and barometric damper
- Low water cut-off

[Terms & Conditions](#) · [Terms of Use](#)

A Mestek Company. Copyright © 2004 Mestek Technology. All Rights Reserved

Subj: **Huttonsville Boiler Quote**
Date: 10/21/2010 6:45:43 P.M. Eastern Daylight Time
From:
To:

Guys,

Here's the quote for the Huttonsville Boiler. Good luck!

Danny Morrison
Industrial Products Group, LLC
Owner
(740) 894-8132
(304) 633-9454
jdg@adominternet.net
75 Twp. Rd. 1079
Chesapeake, Oh 45619
www.industrialproducts-group.com

Job Name: **HUTTONSVILLE CORRECTIONAL CENTER**
HUTTONSVILLE, WV.

Smith Boiler

One (1) G28A-S-6 Pressurized Wet Base Boiler/Burner Unit, knocked down for field assembly. The Boiler has an I=B=R Gross Output of 1433 MBH when fired with 1827 MBH of propane gas. The unit includes:

Powerflame Model J50A-15

Note: This Burner will operate with either PROPANE or Nat. GAS when supplied with between 6.5"– 14" WC of either fuel.

The only modification required when changing over is to change the regulator spring. The unit will ship with a Spring suitable for use on Propane in the regulator.

A Spring for Nat Gas will be shipped loose..

Motor Voltage: 1/115/60

Flame safeguard: Honeywell RM7897A/UV

ASME CSD-1 Approval – low/high/low firing.

Gas train sized for 6.5" W.C. gas pressure available at the inlet to the gas train.

A.S.M.E. Safety Valve set at 15 PSI.

Steam gauge.

McDonnell Miller No. 63M LWCO, manual reset.

McDonnell Miller No. 150S Pump control / LWCO.

One (1) intermediate section tapped 1" on crown sheet for LWCO.

Honeywell L4079B manual reset high limit.

Honeywell PA404A operating control.

Honeywell PA404A firing rate control.

NET PRICE: (one unit) \$11,861.00 Plus Freight

PRODUCT DATA

PD28A-2

 **Smith Steam Boilers [28A Series]**

Pressurized Wet Base
Boiler/Burner Unit

Smith
CAST IRON BOILERS

Designed to provide the highest efficiencies possible with forced draft firing. This new product line of Smith cast iron boilers is available in fifteen basic sizes, with gross output ratings from 931 to 4,622 MBH. Series 28HE boilers may be used in steam systems, and may be fired with light oil, gas or gas/light oil.

STANDARD FEATURES

- Cast iron wet base sections tested for 80 psi working pressure, 15 psi steam working pressure
- Insulated metal jacket
- Burner mounting plate with insulation block
- Front and rear flame observation ports
- Steel angle floor rails
- Ceramic fiber rope seal between sections
- Graphite port connectors
- Flue brush
- Manual reset hi-limit
- Operating control

ADDITIONAL FEATURES FOR STEAM BOILERS

- A.S.M.E. side outlet safety valve, 15 psi
- Gauge glass with cocks and guards

I B R Ratings, Burner Capacities

Designed and tested to the A.S.M.E. boiler and pressure vessel code, section IV for maximum allowable working pressure, steam 15 PSIG, water 80 PSIG.

Boiler Number (Note 1)	Boiler Horse-power	I=B=R Gross Output (MBH)	Net I=B=R Ratings (Note 2)				Heating Surface (Sq. Ft.)	Furnace Volume (Cu. Ft.)	Water Contents (Gals.)	Working Weight (Lbs.)
			Steam		I=B=R Burner Capacity					
			Sq. Ft.	MBH	Oil GPH (Note 3)	Gas MBH (Note 4)			Steam	
†28A-S-4	27	900	2813	675	8.0	1154	81.2	12.04	103.8	4,215
†28A-S-5	35	1166	3646	875	10.4	1491	105.3	16.14	125.8	5,038
†28A-S-6	43	1433	4538	1089	12.6	1827	129.4	20.24	147.8	5,861
†28A-S-7	51	1699	5458	1310	15.0	2163	153.5	24.34	169.8	6,684
†28A-S-8	59	1965	6358	1526	17.4	2499	177.6	28.44	191.8	7,507
†28A-S-9	67	2232	7221	1733	19.6	2836	201.7	32.54	213.8	8,331
†28A-S-10	75	2498	8079	1939	22.0	3172	225.8	36.64	235.8	9,169
†28A-S-11	83	2764	8942	2146	24.5	3508	249.9	40.74	257.8	9,992
†28A-S-12	91	3031	9804	2353	26.5	3844	274.0	44.84	279.8	10,815
†28A-S-13	98	3297	10667	2560	29.0	4180	289.1	48.94	301.8	11,649
†28A-S-14	106	3563	11525	2766	31.5	4517	322.2	53.04	323.8	12,467
†28A-S-15	114	3830	12392	2974	33.5	4853	346.3	57.14	345.8	13,511
†28A-S-16	122	4096	13250	3180	36.0	5189	370.4	61.24	367.8	14,375
†28A-S-17	130	4362	14113	3387	38.5	5525	394.5	65.34	389.8	15,239
†28A-S-18	138	4629	14975	3594	40.5	5862	418.6	69.44	411.8	16,103

(Note 1) Important Ordering information

(†) Add Prefix for type of fuel to be burned. "LO" for light oil, "G" for Gas or "GO" for gas/oil. Example: LO-28A-S-6 is the model no. for a six section steam boiler firing light oil.

(Note 2) Net I=B=R Ratings for steam boilers are based on piping and pick-up factor as follows:
4 and 5 section = 1.333
6 section = 1.305
8 section and larger = 1.288

(Note 3) Light oil having a heat content of 140,000 BTU/Gal.

(Note 4) Gas having a heat content of 1,000 BTU/Cu. Ft., 0.60 specific gravity



28A Series

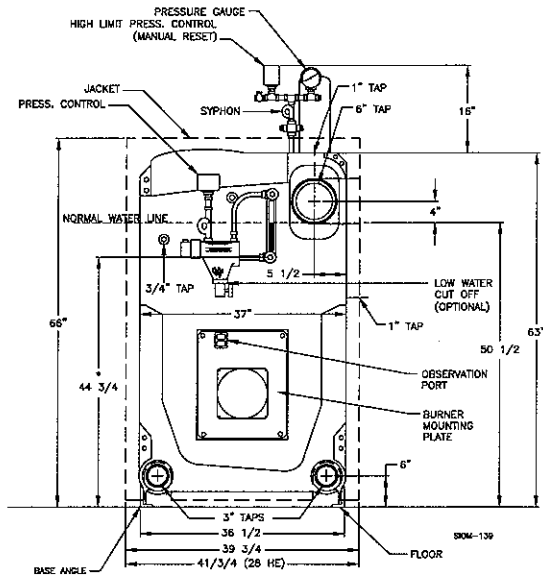

FRONT VIEW (Steam Boiler)

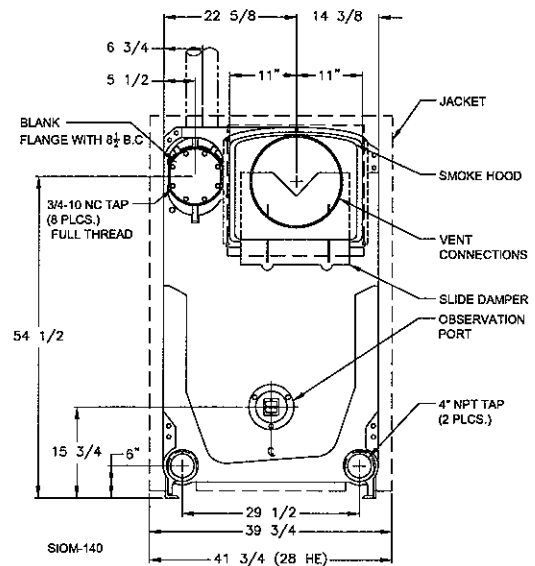

REAR VIEW

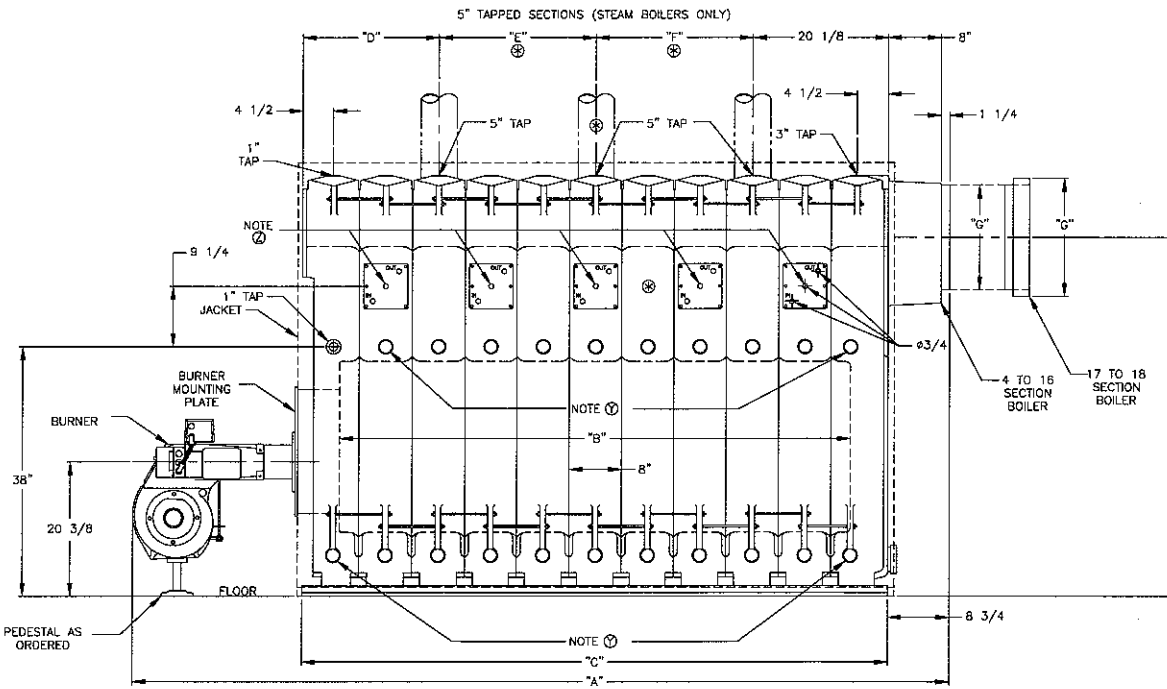

SIDE VIEW

(Note Y) 1-1/2" inspection tappings when ordered.

(Note Z) Tankless heater sections when ordered. Allow 36" clear space for heater withdrawal.

Dimensions (inches)

Boiler Number (Note 1)	Overall Length — "A"				Opt. Packaged Base Dimensions				Furnace Length "B"	Boiler Length "C"	Steam Uptake Locations (Note 9)			Draft Loss Ins. W.C.	Firebox Press Ins. W.C.††	Dia. Vent Conn. "G"	(Note 7) Height Vent Conn. "H"
	(Note 8)				Carlin & Beckett		Power Flame and Webster				"D"	"E"	"F"				
	Carlin	Beckett	Power Flame	Webster	"J"	"K"	"J"	"K"									
†28A-S-4	62½	64	71%	66%	54¼	83¼	54¼	91¼	23½	33	12½	—	—	.24	.34	10	57%
†28A-S-5	70¼	72	83%	74%	62¼	91¼	62¼	104¼	31½	41	20½	—	—	.25	.35	10	57%
†28A-S-6	80%	80¼	91%	82%	70%	99%	70%	112%	39%	49	12½	16	—	.26	.36	10	56%
†28A-S-7	88%	88%	99%	90%	78%	107%	78%	120%	47%	57	12½	24	—	.27	.37	12	56%
†28A-S-8	96%	96%	107%	98%	86½	115%	86½	128%	55%	65	12½	32	—	.28	.38	12	55%
†28A-S-9	108%	104%	115%	110%	96%	123%	94%	136%	63%	73	12½	40	—	.29	.39	14	55%
†28A-S-10	116%	116%	128	118%	102%	135%	102%	144%	71%	81	20½	40	—	.30	.40	14	55%
†28A-S-11	125%	124%	137%	126%	110%	143%	110%	157%	79%	89	20½	24	24	.31	.41	14	55%
†28A-S-12	133%	132½	145%	134%	118%	151%	118%	165%	87%	97	20½	24	32	.33	.43	14	54%
†28A-S-13	141%	—	153%	142%	126%	159%	126%	173%	95%	105	20½	32	32	.34	.44	14	54%
†28A-S-14	149%	—	161%	150%	134%	167%	134%	181%	103%	113	20½	32	40	.35	.45	16	54%
†28A-S-15	—	—	169%	158%	—	—	142%	189%	111%	121	20½	40	40	.36	.46	16	54%
†28A-S-16	—	—	177%	166%	—	—	150%	198	119%	129	20½	48	40	.37	.47	16	54%
†28A-S-17	—	—	191%	183%	—	—	159	206	127%	137	20½	48	48	.38	.48	18	54%
†28A-S-18	—	—	199%	191%	—	—	167%	214%	135%	145	20½	56	48	.39	.49	18	54%

(Note 7) When unit is assembled or packaged, add 6" to heights for 4-14 sect., 8" to heights for 15-18 sect.

(Note 8) Add 2-3/4" to sect. 14 thru 18 for smoke hood adaptor.

†† Based on 0.10 ins. W.C. pressure at boiler outlet. If vent sizing results in a back pressure greater than 0.10 ins. W.C., consult Smith

(Note 9) These measurements are approximate. The Smith representative should be consulted before selecting boilers for installation having unusual piping and pick-up requirements, such as intermittent system operation, extensive piping systems, etc. The boiler ratings have been determined under previous governing forced draft units.

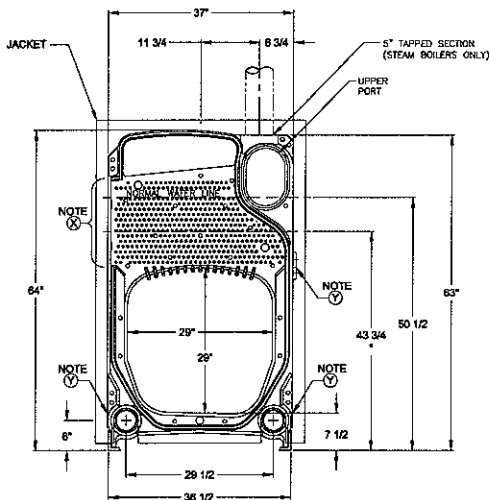

INTERMEDIATE VIEW

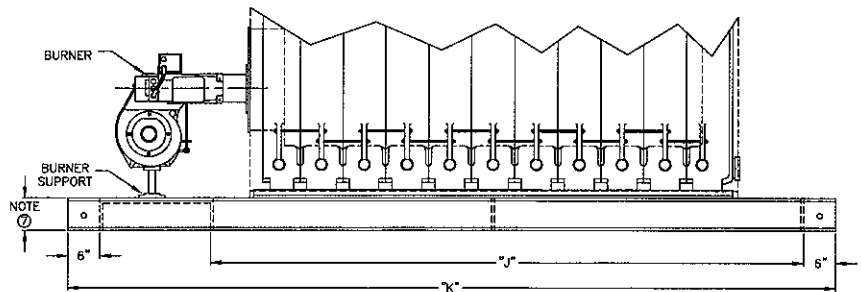

TYPICAL ASSEMBLY – SIDE VIEW

(NOTE X) Flue cleanout opening. Allow 36" clear work space for using flue brush, and for the removal of the heat transfer rods.

Recommended Steam Piping Diagram

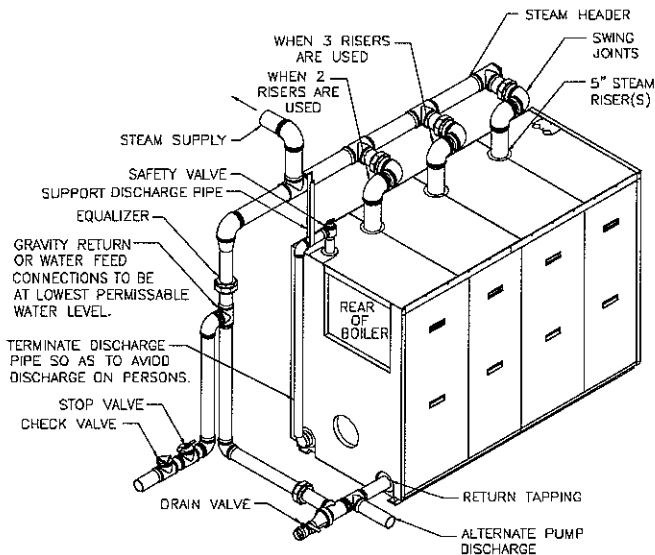

Boiler Section	No. of		
	5" Risers	Header	Equalizer
28A-S-4 & 5	1	5"	2-1/2"
28A-S-6 & 7	2	5"	2-1/2"
28A-S-8 thru 10	2	6"	4"
28A-S-11 thru 18	3	8"	4"

Burner Specifications

Boiler Number	Burners - Light Oil						Burners - Gas		Burners - Gas/Oil	
	Carlin (Note 5)		Beckett (Note 5)		Power Flame (Note 6)		Power Flame (Note 7)		Power Flame (Note 8)	
	Model No.	H.P.	Model No.	H.P.	Model No.	H.P.	Model No.	H.P.	Model No.	H.P.
†28A-S-4	702CRD	1/2	CF1400	1/2	C1-0	1/2	J30A-12	1/2	C1-G0-12	1/2
†28A-S-5	702CRD	1/2	CF1400	3/4	C1-0	1/2	J50A-15	1/2	C1-G0-12	1/2
†28A-S-6	801CRD	3/4	CF1400	3/4	C2-0A	3/4	J50A-15	1/2	C2-G0-15	3/4
†28A-S-7	801CRD	3/4	CF1400	3/4	C2-0A	3/4	J50A-15	1/2	C2-G0-15	3/4
†28A-S-8	801CRD	3/4	CF1400	2	C2-0B	3/4	C2-G-20A	3/4	C2-G0-20A	1
†28A-S-9	1050FFD	1	CF2300	2	C2-0B-1	1 1/2	C2-G-20B-1	1	C2-G0-20B-1	1 1/2
†28A-S-10	1050FFD	1	CF2500	2	C2-0B-1	1 1/2	C2-G-20B-1	1	C2-G0-20B-1	1 1/2
†28A-S-11	1150FFD	1 1/2	CF2500	2	C3-0	2	C3-G-20	1 1/2	C3-G0-20	2
†28A-S-12	1150FFD	1 1/2	CF3500A	2	C3-0	2	C3-G-25	1 1/2	C3-G0-25	2
†28A-S-13	1150FFD	1 1/2	CF3500A	2	C3-0	2	C3-G-25	1 1/2	C3-G0-25	2
†28A-S-14	1150FFD	1 1/2	---	---	C3-0	2	C3-G-25	1 1/2	C3-G0-25	2
†28A-S-15	---	---	---	---	C3-0B	3	C3-G-25B	3	C3-G0-25B	3
†28A-S-16	---	---	---	---	C3-0B	3	C3-G-25B	3	C3-G0-25B	3
†28A-S-17	---	---	---	---	C4-0A	5	C4-G-25	3	C4-G0-25	5
†28A-S-18	---	---	---	---	C4-0A	5	C4-G-25	3	C4-G0-25	5

(Note 5) Burner operation: Low-High-Low (4-13 sect.).

(Note 6) Burner operation: Low-High-Low, (4-9 sect.); Modulation (10-18 sect.).

Smith
CAST IRON BOILERS

WESTCAST, INC.
260 NORTH ELM STREET WESTFIELD, MA 01085
TEL. (413) 562-9631 FAX (413) 562-3799
www.smithboiler.com

BID BOND

KNOW ALL MEN BY THESE PRESENTS, That we, the undersigned, Harris Brothers Roofing & Sheet Metal Company, Inc.
of Charleston, WV, as Principal, and Travelers Casualty and Surety Company of America
of Hartford, CT, a corporation organized and existing under the laws of the State of
CT with its principal office in the City of Hartford, as Surety, are held and firmly bound unto the State
of West Virginia, as Obligee, in the penal sum of Five Percent of Amount Bid (\$ 5%) for the payment of which,
well and truly to be made, we jointly and severally bind ourselves, our heirs, administrators, executors, successors and assigns.

The Condition of the above obligation is such that whereas the Principal has submitted to the Purchasing Section of the
Department of Administration a certain bid or proposal, attached hereto and made a part hereof, to enter into a contract in writing for
COR61459 Huttonsville Correctional Center Steam Boiler Maintenance and Repair - According to Plans and
Specifications

NOW THEREFORE,

- (a) If said bid shall be rejected, or
- (b) If said bid shall be accepted and the Principal shall enter into a contract in accordance with the bid or proposal attached
hereto and shall furnish any other bonds and insurance required by the bid or proposal, and shall in all other respects perform the
agreement created by the acceptance of said bid, then this obligation shall be null and void, otherwise this obligation shall remain in full
force and effect. It is expressly understood and agreed that the liability of the Surety for any and all claims hereunder shall, in no event,
exceed the penal amount of this obligation as herein stated.

The Surety, for the value received, hereby stipulates and agrees that the obligations of said Surety and its bond shall be in no
way impaired or affected by any extension of the time within which the Obligee may accept such bid, and said Surety does hereby
waive notice of any such extension.

IN WITNESS WHEREOF, Principal and Surety have hereunto set their hands and seals, and such of them as are corporations
have caused their corporate seals to be affixed hereunto and these presents to be signed by their proper officers, this
28th day of October, 2010.

Principal Corporate Seal

Harris Brothers Roofing & Sheet Metal Company, Inc.
(Name of Principal)
By Grey Harris
(Must be President or
Vice President)
VP.
(Title)

Surety Corporate Seal

Travelers Casualty and Surety Company of America
(Name of Surety)
By Kimberly J. Wilkinson
Kimberly J. Wilkinson, WV Resident Agent Attorney-in-Fact

IMPORTANT – Surety executing bonds must be licensed in West Virginia to transact surety insurance. Corporate seals must be affixed,
and a power of attorney must be attached.



POWER OF ATTORNEY

Farmington Casualty Company
Fidelity and Guaranty Insurance Company
Fidelity and Guaranty Insurance Underwriters, Inc.
St. Paul Fire and Marine Insurance Company
St. Paul Guardian Insurance Company

St. Paul Mercury Insurance Company
Travelers Casualty and Surety Company
Travelers Casualty and Surety Company of America
United States Fidelity and Guaranty Company

Attorney-In Fact No. 220367

Certificate No. 003659097

KNOW ALL MEN BY THESE PRESENTS: That St. Paul Fire and Marine Insurance Company, St. Paul Guardian Insurance Company and St. Paul Mercury Insurance Company are corporations duly organized under the laws of the State of Minnesota, that Farmington Casualty Company, Travelers Casualty and Surety Company, and Travelers Casualty and Surety Company of America are corporations duly organized under the laws of the State of Connecticut, that United States Fidelity and Guaranty Company is a corporation duly organized under the laws of the State of Maryland, that Fidelity and Guaranty Insurance Company is a corporation duly organized under the laws of the State of Iowa, and that Fidelity and Guaranty Insurance Underwriters, Inc., is a corporation duly organized under the laws of the State of Wisconsin (herein collectively called the "Companies"), and that the Companies do hereby make, constitute and appoint

Gregory T. Gordon, Patricia A. Moyer, Larry D. Kerr, Allan L. McVey, and Kimberly J. Wilkinson

of the City of Charleston, State of West Virginia, their true and lawful Attorney(s)-in-Fact, each in their separate capacity if more than one is named above, to sign, execute, seal and acknowledge any and all bonds, recognizances, conditional undertakings and other writings obligatory in the nature thereof on behalf of the Companies in their business of guaranteeing the fidelity of persons, guaranteeing the performance of contracts and executing or guaranteeing bonds and undertakings required or permitted in any actions or proceedings allowed by law.

IN WITNESS WHEREOF, the Companies have caused this instrument to be signed and their corporate seals to be hereto affixed, this 11th day of May, 2010.

Farmington Casualty Company
Fidelity and Guaranty Insurance Company
Fidelity and Guaranty Insurance Underwriters, Inc.
St. Paul Fire and Marine Insurance Company
St. Paul Guardian Insurance Company

St. Paul Mercury Insurance Company
Travelers Casualty and Surety Company
Travelers Casualty and Surety Company of America
United States Fidelity and Guaranty Company



State of Connecticut
City of Hartford ss.

By: [Signature]
George W. Thompson, Senior Vice President

On this the 11th day of May, 2010, before me personally appeared George W. Thompson, who acknowledged himself to be the Senior Vice President of Farmington Casualty Company, Fidelity and Guaranty Insurance Company, Fidelity and Guaranty Insurance Underwriters, Inc., St. Paul Fire and Marine Insurance Company, St. Paul Guardian Insurance Company, St. Paul Mercury Insurance Company, Travelers Casualty and Surety Company, Travelers Casualty and Surety Company of America, and United States Fidelity and Guaranty Company, and that he, as such, being authorized so to do, executed the foregoing instrument for the purposes therein contained by signing on behalf of the corporations by himself as a duly authorized officer.

In Witness Whereof, I hereunto set my hand and official seal.
My Commission expires the 30th day of June, 2011.



[Signature]
Marie C. Tetreault, Notary Public

This Power of Attorney is granted under and by the authority of the following resolutions adopted by the Boards of Directors of Farmington Casualty Company, Fidelity and Guaranty Insurance Company, Fidelity and Guaranty Insurance Underwriters, Inc., St. Paul Fire and Marine Insurance Company, St. Paul Guardian Insurance Company, St. Paul Mercury Insurance Company, Travelers Casualty and Surety Company, Travelers Casualty and Surety Company of America, and United States Fidelity and Guaranty Company, which resolutions are now in full force and effect, reading as follows:

RESOLVED, that the Chairman, the President, any Vice Chairman, any Executive Vice President, any Senior Vice President, any Vice President, any Second Vice President, the Treasurer, any Assistant Treasurer, the Corporate Secretary or any Assistant Secretary may appoint Attorneys-in-Fact and Agents to act for and on behalf of the Company and may give such appointee such authority as his or her certificate of authority may prescribe to sign with the Company's name and seal with the Company's seal bonds, recognizances, contracts of indemnity, and other writings obligatory in the nature of a bond, recognizance, or conditional undertaking, and any of said officers or the Board of Directors at any time may remove any such appointee and revoke the power given him or her; and it is

FURTHER RESOLVED, that the Chairman, the President, any Vice Chairman, any Executive Vice President, any Senior Vice President or any Vice President may delegate all or any part of the foregoing authority to one or more officers or employees of this Company, provided that each such delegation is in writing and a copy thereof is filed in the office of the Secretary; and it is

FURTHER RESOLVED, that any bond, recognizance, contract of indemnity, or writing obligatory in the nature of a bond, recognizance, or conditional undertaking shall be valid and binding upon the Company when (a) signed by the President, any Vice Chairman, any Executive Vice President, any Senior Vice President or any Vice President, any Second Vice President, the Treasurer, any Assistant Treasurer, the Corporate Secretary or any Assistant Secretary and duly attested and sealed with the Company's seal by a Secretary or Assistant Secretary; or (b) duly executed (under seal, if required) by one or more Attorneys-in-Fact and Agents pursuant to the power prescribed in his or her certificate or their certificates of authority or by one or more Company officers pursuant to a written delegation of authority; and it is

FURTHER RESOLVED, that the signature of each of the following officers: President, any Executive Vice President, any Senior Vice President, any Vice President, any Assistant Vice President, any Secretary, any Assistant Secretary, and the seal of the Company may be affixed by facsimile to any Power of Attorney or to any certificate relating thereto appointing Resident Vice Presidents, Resident Assistant Secretaries or Attorneys-in-Fact for purposes only of executing and attesting bonds and undertakings and other writings obligatory in the nature thereof, and any such Power of Attorney or certificate bearing such facsimile signature or facsimile seal shall be valid and binding upon the Company and any such power so executed and certified by such facsimile signature and facsimile seal shall be valid and binding on the Company in the future with respect to any bond or understanding to which it is attached.

I, Kori M. Johanson, the undersigned, Assistant Secretary, of Farmington Casualty Company, Fidelity and Guaranty Insurance Company, Fidelity and Guaranty Insurance Underwriters, Inc., St. Paul Fire and Marine Insurance Company, St. Paul Guardian Insurance Company, St. Paul Mercury Insurance Company, Travelers Casualty and Surety Company, Travelers Casualty and Surety Company of America, and United States Fidelity and Guaranty Company do hereby certify that the above and foregoing is a true and correct copy of the Power of Attorney executed by said Companies, which is in full force and effect and has not been revoked.

IN TESTIMONY WHEREOF, I have hereunto set my hand and affixed the seals of said Companies this 28th day of October, 20 10.

WARNING: THIS POWER OF ATTORNEY IS INVALID WITHOUT THE RED BORDER

Kori M. Johanson, Assistant Secretary



To verify the authenticity of this Power of Attorney, call 1-800-421-3880 or contact us at www.travelersbond.com. Please refer to the Attorney-In-Fact number, the above-named individuals and the details of the bond to which the power is attached.



State of West Virginia
DRUG FREE WORKPLACE CONFORMANCE AFFIDAVIT
West Virginia Code §21-1D-5

STATE OF WEST VIRGINIA

COUNTY OF KANAWHA, TO-WIT:

I, Grey Harris, after being first duly sworn, depose and state as follows:

- 1. I am an employee of Harris Brothers Roofing & Sheet Metal; and,
(Company Name)
- 2. I do hereby attest that Harris Brothers Roofing & Sheet Metal Co.
(Company Name)

maintains a valid written drug free workplace policy and that such policy is in compliance with **West Virginia Code** §21-1D-5.

The above statements are sworn to under the penalty of perjury.

Harris Brothers Roofing & Sheet Metal Co., Inc.
(Company Name)

By: Grey Harris

Title: Vice President

Date: 10/28/2010

Taken, subscribed and sworn to before me this 28th day of Oct., 2010.

By Commission expires August 3, 2014

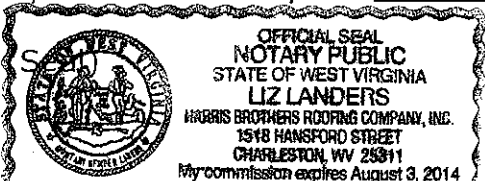

Liz Landers
(Notary Public)

THIS AFFIDAVIT MUST BE SUBMITTED WITH THE BID IN ORDER TO COMPLY WITH WV CODE PROVISIONS. FAILURE TO INCLUDE THE AFFIDAVIT WITH THE BID SHALL RESULT IN DISQUALIFICATION OF THE BID.

RFQ No. COR61459

STATE OF WEST VIRGINIA
Purchasing Division

PURCHASING AFFIDAVIT

West Virginia Code §5A-3-10a states: No contract or renewal of any contract may be awarded by the state or any of its political subdivisions to any vendor or prospective vendor when the vendor or prospective vendor or a related party to the vendor or prospective vendor is a debtor and the debt owed is an amount greater than one thousand dollars in the aggregate.

DEFINITIONS:

"Debt" means any assessment, premium, penalty, fine, tax or other amount of money owed to the state or any of its political subdivisions because of a judgment, fine, permit violation, license assessment, defaulted workers' compensation premium, penalty or other assessment presently delinquent or due and required to be paid to the state or any of its political subdivisions, including any interest or additional penalties accrued thereon.

"Debtor" means any individual, corporation, partnership, association, limited liability company or any other form or business association owing a debt to the state or any of its political subdivisions. "Political subdivision" means any county commission; municipality; county board of education; any instrumentality established by a county or municipality; any separate corporation or instrumentality established by one or more counties or municipalities, as permitted by law; or any public body charged by law with the performance of a government function or whose jurisdiction is coextensive with one or more counties or municipalities. "Related party" means a party, whether an individual, corporation, partnership, association, limited liability company or any other form or business association or other entity whatsoever, related to any vendor by blood, marriage, ownership or contract through which the party has a relationship of ownership or other interest with the vendor so that the party will actually or by effect receive or control a portion of the benefit, profit or other consideration from performance of a vendor contract with the party receiving an amount that meets or exceed five percent of the total contract amount.

EXCEPTION: The prohibition of this section does not apply where a vendor has contested any tax administered pursuant to chapter eleven of this code, workers' compensation premium, permit fee or environmental fee or assessment and the matter has not become final or where the vendor has entered into a payment plan or agreement and the vendor is not in default of any of the provisions of such plan or agreement.

Under penalty of law for false swearing (*West Virginia Code* §61-5-3), it is hereby certified that the vendor affirms and acknowledges the information in this affidavit and is in compliance with the requirements as stated.

WITNESS THE FOLLOWING SIGNATURE

Vendor's Name: Harris Brothers Roofing & Sheet Metal Company, Inc.

Authorized Signature: *Guy Harvi* Date: 10/28/2010

State of West Virginia

County of Kanawha, to-wit:

Taken, subscribed, and sworn to before me this 28 day of October, 2010.

My Commission expires August 3, 2014.

NOTARY PUBLIC

Liz Landers

