



State of West Virginia  
 Department of Administration  
 Purchasing Division  
 2019 Washington Street East  
 Post Office Box 50130  
 Charleston, WV 25305-0130

# Request for Quotation

RFQ NUMBER  
**8511C2008**

PAGE  
**1**

ADDRESS CORRESPONDENCE TO ATTENTION OF  
**BUYER 33**  
**304-558-2402**

**\*216111625 304-453-5636**  
**HIGHWAY SAFETY INC**  
**PO BOX 908**  
**CEREDO WV 25507-0908**

**DIVISION OF HIGHWAYS**  
**VARIOUS LOCALES AS INDICATED**  
**BY ORDER**

DATE PRINTED	TERMS OF SALE	SHIP VIA	F.O.B.	FREIGHT TERMS
08/12/2010				

BID OPENING DATE: **09/08/2010** BID OPENING TIME **01:30PM**

LINE	QUANTITY	UOP	CAT NO	ITEM NUMBER	UNIT PRICE	AMOUNT
0001	1	EA		550-85		260,457.55
PORTABLE SIGN STANDS AND REFL. ROLL-UP SIGNS  OPEN END CONTRACT  TO PROVIDE COMPACT PORTABLE SIGN STANDS AND HIGHLY REFLECTIVE ROLL-UP SIGNS FOR THE WEST VIRGINIA DIVISION OF HIGHWAYS PER THE ATTACHED SPECIFICATIONS AND DRAWINGS.  THE FOLLOWING ESTIMATED QUANTITIES ARE FOR BID PURPOSES ONLY AND THE ACTUAL QUANTITIES MY BE INCREASED OR DECREASED AS NEEDED.  PURCHASING CARD ACCEPTANCE: THE STATE OF WEST VIRGINIA CURRENTLY UTILIZES A VISA PURCHASING CARD PROGRAM WHICH IS ISSUED THROUGH A BANK. THE SUCCESSFUL VENDOR MUST ACCEPT THE STATE OF WEST VIRGINIA VISA PURCHASING CARD FOR PAYMENT OF ALL ORDERS PLACED BY ANY STATE AGENCY AS A CONDITION OF AWARD.  EXHIBIT 3  LIFE OF CONTRACT: THIS CONTRACT BECOMES EFFECTIVE ON ..... AND EXTENDS FOR A PERIOD OF ONE (1) YEAR OR UNTIL SUCH "REASONABLE TIME" THEREAFTER AS IS NECESSARY TO OBTAIN A NEW CONTRACT OR RENEW THE ORIGINAL CONTRACT. THE "REASONABLE TIME" PERIOD SHALL						

**RECEIVED**  
**2010 SEP -7 PM 3:08**  
**WV PURCHASING DIVISION**

SEE REVERSE SIDE FOR TERMS AND CONDITIONS

SIGNATURE <i>Don P Booth</i>	TELEPHONE <b>304-453-5636</b>	DATE <b>9-7-10</b>
TITLE <b>President</b>	FEIN <b>55-0719851</b>	ADDRESS CHANGES TO BE NOTED ABOVE

WHEN RESPONDING TO RFQ, INSERT NAME AND ADDRESS IN SPACE ABOVE LABELED 'VENDOR'

**GENERAL TERMS & CONDITIONS  
REQUEST FOR QUOTATION (RFQ) AND REQUEST FOR PROPOSAL (RFP)**

1. Awards will be made in the best interest of the State of West Virginia.
2. The State may accept or reject in part, or in whole, any bid.
3. Prior to any award, the apparent successful vendor must be properly registered with the Purchasing Division and have paid the required \$125 fee.
4. All services performed or goods delivered under State Purchase Order/Contracts are to be continued for the term of the Purchase Order/Contracts, contingent upon funds being appropriated by the Legislature or otherwise being made available. In the event funds are not appropriated or otherwise available for these services or goods this Purchase Order/Contract becomes void and of no effect after June 30.
5. Payment may only be made after the delivery and acceptance of goods or services.
6. Interest may be paid for late payment in accordance with the *West Virginia Code*.
7. Vendor preference will be granted upon written request in accordance with the *West Virginia Code*.
8. The State of West Virginia is exempt from federal and state taxes and will not pay or reimburse such taxes.
9. The Director of Purchasing may cancel any Purchase Order/Contract upon 30 days written notice to the seller.
10. The laws of the State of West Virginia and the *Legislative Rules* of the Purchasing Division shall govern the purchasing process.
11. Any reference to automatic renewal is hereby deleted. The Contract may be renewed only upon mutual written agreement of the parties.
12. **BANKRUPTCY:** In the event the vendor/contractor files for bankruptcy protection, the State may deem this contract null and void, and terminate such contract without further order.
13. **HIPAA BUSINESS ASSOCIATE ADDENDUM:** The West Virginia State Government HIPAA Business Associate Addendum (BAA), approved by the Attorney General, is available online at [www.state.wv.us/admin/purchase/vrc/hipaa.htm](http://www.state.wv.us/admin/purchase/vrc/hipaa.htm) and is hereby made part of the agreement. Provided that the Agency meets the definition of a Cover Entity (45 CFR §160.103) and will be disclosing Protected Health Information (45 CFR §160.103) to the vendor.
14. **CONFIDENTIALITY:** The vendor agrees that he or she will not disclose to anyone, directly or indirectly, any such personally identifiable information or other confidential information gained from the agency, unless the individual who is the subject of the information consents to the disclosure in writing or the disclosure is made pursuant to the agency's policies, procedures, and rules. Vendor further agrees to comply with the Confidentiality Policies and Information Security Accountability Requirements, set forth in <http://www.state.wv.us/admin/purchase/privacy/noticeConfidentiality.pdf>.
15. **LICENSING:** Vendors must be licensed and in good standing in accordance with any and all state and local laws and requirements by any state or local agency of West Virginia, including, but not limited to, the West Virginia Secretary of State's Office, the West Virginia Tax Department, and the West Virginia Insurance Commission. The vendor must provide all necessary releases to obtain information to enable the director or spending unit to verify that the vendor is licensed and in good standing with the above entities.
16. **ANTITRUST:** In submitting a bid to any agency for the State of West Virginia, the bidder offers and agrees that if the bid is accepted the bidder will convey, sell, assign or transfer to the State of West Virginia all rights, title and interest in and to all causes of action it may now or hereafter acquire under the antitrust laws of the United States and the State of West Virginia for price fixing and/or unreasonable restraints of trade relating to the particular commodities or services purchased or acquired by the State of West Virginia. Such assignment shall be made and become effective at the time the purchasing agency tenders the initial payment to the bidder.

I certify that this bid is made without prior understanding, agreement, or connection with any corporation, firm, limited liability company, partnership, or person or entity submitting a bid for the same material, supplies, equipment or services and is in all respects fair and without collusion or Fraud. I further certify that I am authorized to sign the certification on behalf of the bidder or this bid.

**INSTRUCTIONS TO BIDDERS**

1. Use the quotation forms provided by the Purchasing Division. Complete all sections of the quotation form.
2. Items offered must be in compliance with the specifications. Any deviation from the specifications must be clearly indicated by the bidder. Alternates offered by the bidder as **EQUAL** to the specifications must be clearly defined. A bidder offering an alternate should attach complete specifications and literature to the bid. The Purchasing Division may waive minor deviations to specifications.
3. Unit prices shall prevail in case of discrepancy. All quotations are considered F.O.B. destination unless alternate shipping terms are clearly identified in the quotation.
4. All quotations must be delivered by the bidder to the office listed below prior to the date and time of the bid opening. Failure of the bidder to deliver the quotations on time will result in bid disqualifications: Department of Administration, Purchasing Division, 2019 Washington Street East, P.O. Box 50130, Charleston, WV 25305-0130
5. Communication during the solicitation, bid, evaluation or award periods, except through the Purchasing Division, is strictly prohibited (W.Va. C.S.R. §148-1-6.6).



State of West Virginia  
 Department of Administration  
 Purchasing Division  
 2019 Washington Street East  
 Post Office Box 50130  
 Charleston, WV 25305-0130

# Request for Quotation

RFQ NUMBER  
**8511C2008**

PAGE  
**2**

ADDRESS CORRESPONDENCE TO ATTENTION OF  
**BUYER 33**  
**304-558-2402**

VENDOR

\*216111625      304-453-5636  
 HIGHWAY SAFETY INC  
 PO BOX 908  
  
 CEREDO WV 25507-0908

SHIP TO

DIVISION OF HIGHWAYS  
 VARIOUS LOCALES AS INDICATED  
 BY ORDER

DATE PRINTED	TERMS OF SALE	SHIP VIA	F.O.B.	FREIGHT TERMS
08/12/2010				

BID OPENING DATE: **09/08/2010**      BID OPENING TIME **01:30PM**

LINE	QUANTITY	UOP	CAT NO	ITEM NUMBER	UNIT PRICE	AMOUNT
<p>NOT EXCEED TWELVE (12) MONTHS. DURING THIS "REASONABLE TIME" THE VENDOR MAY TERMINATE THIS CONTRACT FOR ANY REASON UPON GIVING THE DIRECTOR OF PURCHASING 30 DAYS WRITTEN NOTICE.</p> <p>UNLESS SPECIFIC PROVISIONS ARE STIPULATED ELSEWHERE IN THIS CONTRACT DOCUMENT, THE TERMS, CONDITIONS AND PRICING SET HEREIN ARE FIRM FOR THE LIFE OF THE CONTRACT.</p> <p>RENEWAL: THIS CONTRACT MAY BE RENEWED UPON THE MUTUAL WRITTEN CONSENT OF THE SPENDING UNIT AND VENDOR, SUBMITTED TO THE DIRECTOR OF PURCHASING THIRTY (30) DAYS PRIOR TO THE EXPIRATION DATE. SUCH RENEWAL SHALL BE IN ACCORDANCE WITH THE TERMS AND CONDITIONS OF THE ORIGINAL CONTRACT AND SHALL BE LIMITED TO TWO (2) ONE (1) YEAR PERIODS.</p> <p>CANCELLATION: THE DIRECTOR OF PURCHASING RESERVES THE RIGHT TO CANCEL THIS CONTRACT IMMEDIATELY UPON WRITTEN NOTICE TO THE VENDOR IF THE COMMODITIES AND/OR SERVICES SUPPLIED ARE OF AN INFERIOR QUALITY OR DO NOT CONFORM TO THE SPECIFICATIONS OF THE BID AND CONTRACT HEREIN.</p> <p>OPEN MARKET CLAUSE: THE DIRECTOR OF PURCHASING MAY AUTHORIZE A SPENDING UNIT TO PURCHASE ON THE OPEN MARKET, WITHOUT THE FILING OF A REQUISITION OR COST ESTIMATE, ITEMS SPECIFIED ON THIS CONTRACT FOR IMMEDIATE DELIVERY IN EMERGENCIES DUE TO UNFORESEEN CAUSES (INCLUDING BUT NOT LIMITED TO DELAYS IN TRANSPORTATION OR AN UNANTICIPATED INCREASE IN THE VOLUME OF WORK.)</p> <p>QUANTITIES: QUANTITIES LISTED IN THE REQUISITION ARE APPROXIMATIONS ONLY, BASED ON ESTIMATES SUPPLIED BY THE STATE SPENDING UNIT. IT IS UNDERSTOOD AND AGREED</p>						

SEE REVERSE SIDE FOR TERMS AND CONDITIONS

SIGNATURE <i>Don P. Booth</i>	TELEPHONE 304 453-5636	DATE 9-7-10
TITLE President	FEIN 55-0719851	ADDRESS CHANGES TO BE NOTED ABOVE

WHEN RESPONDING TO RFQ, INSERT NAME AND ADDRESS IN SPACE ABOVE LABELED 'VENDOR'



State of West Virginia  
 Department of Administration  
 Purchasing Division  
 2019 Washington Street East  
 Post Office Box 50130  
 Charleston, WV 25305-0130

# Request for Quotation

RFO NUMBER  
**8511C2008**

PAGE  
**3**

ADDRESS CORRESPONDENCE TO ATTENTION OF  
**BUYER 33  
 304-558-2402**

**VENDOR**  
 \*216111625      304-453-5636  
 HIGHWAY SAFETY INC  
 PO BOX 908  
 CEREDO WV 25507-0908

**SHIP TO**  
 DIVISION OF HIGHWAYS  
 VARIOUS LOCALES AS INDICATED  
 BY ORDER

DATE PRINTED	TERMS OF SALE	SHIP VIA	F.O.B.	FREIGHT TERMS
08/12/2010				

BID OPENING DATE: **09/08/2010**      BID OPENING TIME **01:30PM**

LINE	QUANTITY	UOP	CAT NO	ITEM NUMBER	UNIT PRICE	AMOUNT
<p>THAT THE CONTRACT SHALL COVER THE QUANTITIES ACTUALLY ORDERED FOR DELIVERY DURING THE TERM OF THE CONTRACT, WHETHER MORE OR LESS THAN THE QUANTITIES SHOWN.</p> <p>ORDERING PROCEDURE: SPENDING UNIT(S) SHALL ISSUE A WRITTEN STATE CONTRACT ORDER (FORM NUMBER WV-39) TO THE VENDOR FOR COMMODITIES COVERED BY THIS CONTRACT. THE ORIGINAL COPY OF THE WV-39 SHALL BE MAILED TO THE VENDOR AS AUTHORIZATION FOR SHIPMENT, A SECOND COPY MAILED TO THE PURCHASING DIVISION, AND A THIRD COPY RETAINED BY THE SPENDING UNIT.</p> <p>BANKRUPTCY: IN THE EVENT THE VENDOR/CONTRACTOR FILES FOR BANKRUPTCY PROTECTION, THE STATE MAY DEEM THE CONTRACT NULL AND VOID, AND TERMINATE SUCH CONTRACT WITHOUT FURTHER ORDER.</p> <p>THE TERMS AND CONDITIONS CONTAINED IN THIS CONTRACT SHALL SUPERSEDE ANY AND ALL SUBSEQUENT TERMS AND CONDITIONS WHICH MAY APPEAR ON ANY ATTACHED PRINTED DOCUMENTS SUCH AS PRICE LISTS, ORDER FORMS, SALES AGREEMENTS OR MAINTENANCE AGREEMENTS, INCLUDING ANY ELECTRONIC MEDIUM SUCH AS CD-ROM.</p> <p>REV. 05/26/2009</p> <p>EXHIBIT 10</p> <p style="text-align: right;">REQUISITION NO.: <b>8511C2008</b></p> <p>ADDENDUM ACKNOWLEDGEMENT</p> <p>I HEREBY ACKNOWLEDGE RECEIPT OF THE FOLLOWING CHECKED ADDENDUM(S) AND HAVE MADE THE NECESSARY REVISIONS TO MY PROPOSAL, PLANS AND/OR SPECIFICATION, ETC.</p>						

SEE REVERSE SIDE FOR TERMS AND CONDITIONS

SIGNATURE <i>Don P Boatr</i>	TELEPHONE <b>304-453-5636</b>	DATE <b>9-7-10</b>
TITLE <b>President</b>	FEIN <b>55-0719851</b>	ADDRESS CHANGES TO BE NOTED ABOVE

WHEN RESPONDING TO RFO, INSERT NAME AND ADDRESS IN SPACE ABOVE LABELED 'VENDOR'



State of West Virginia  
 Department of Administration  
 Purchasing Division  
 2019 Washington Street East  
 Post Office Box 50130  
 Charleston, WV 25305-0130

# Request for Quotation

RFQ NUMBER  
**8511C2008**

PAGE  
**4**

ADDRESS CORRESPONDENCE TO ATTENTION OF  
**BUYER 33  
 304-558-2402**

\*216111625      304-453-5636  
 HIGHWAY SAFETY INC  
 PO BOX 908  
  
 CEREDO WV 25507-0908

DIVISION OF HIGHWAYS  
 VARIOUS LOCALES AS INDICATED  
 BY ORDER

DATE PRINTED	TERMS OF SALE	SHIP VIA	F.O.B.	FREIGHT TERMS
08/12/2010				

BID OPENING DATE: **09/08/2010**      BID OPENING TIME **01:30PM**

LINE	QUANTITY	UOP	CAT. NO.	ITEM NUMBER	UNIT PRICE	AMOUNT
ADDENDUM NO.'S: NO. 1 ..... NO. 2 ..... NO. 3 ..... NO. 4 ..... NO. 5 .....  I UNDERSTAND THAT FAILURE TO CONFIRM THE RECEIPT OF THE ADDENDUM(S) MAY BE CAUSE FOR REJECTION OF BIDS.  VENDOR MUST CLEARLY UNDERSTAND THAT ANY VERBAL REPRESENTATION MADE OR ASSUMED TO BE MADE DURING ANY ORAL DISCUSSION HELD BETWEEN VENDOR'S REPRESENTATIVES AND ANY STATE PERSONNEL IS NOT BINDING. ONLY THE INFORMATION ISSUED IN WRITING AND ADDED TO THE SPECIFICATIONS BY AN OFFICIAL ADDENDUM IS BINDING.  <div style="text-align: right;"> <i>Gar P Booth</i>            .....            SIGNATURE  <i>Highway Safety Inc.</i>            .....            COMPANY  <i>9-7-10</i>            .....            DATE         </div> NOTE: THIS ADDENDUM ACKNOWLEDGEMENT SHOULD BE SUBMITTED WITH THE BID.						

SEE REVERSE SIDE FOR TERMS AND CONDITIONS			
SIGNATURE <i>Gar P Booth</i>	TELEPHONE <i>304-453-5636</i>	DATE <i>9-7-10</i>	
TITLE <i>President</i>	FEIN <i>55-0719851</i>	ADDRESS CHANGES TO BE NOTED ABOVE	

WHEN RESPONDING TO RFQ, INSERT NAME AND ADDRESS IN SPACE ABOVE LABELED 'VENDOR'





State of West Virginia  
 Department of Administration  
 Purchasing Division  
 2019 Washington Street East  
 Post Office Box 50130  
 Charleston, WV 25305-0130

# Request for Quotation

RFQ NUMBER  
**8511C2008**

PAGE  
**6**

ADDRESS CORRESPONDENCE TO ATTENTION OF  
**BUYER 33**  
**304-558-2402**

BUYER

\*216111625      304-453-5636  
 HIGHWAY SAFETY INC  
 PO BOX 908  
 CEREDO WV 25507-0908

SHIP TO

DIVISION OF HIGHWAYS  
 VARIOUS LOCALES AS INDICATED  
 BY ORDER

DATE PRINTED	TERMS OF SALE	SHIP VIA	F.O.B.	FREIGHT TERMS
08/12/2010				

BID OPENING DATE: **09/08/2010**      BID OPENING TIME **01:30PM**

LINE	QUANTITY	UOP	CAT NO	ITEM NUMBER	UNIT PRICE	AMOUNT
***** THIS IS THE END OF RFQ 8511C2008 ***** TOTAL:						<u>260,457.55</u>

SEE REVERSE SIDE FOR TERMS AND CONDITIONS

SIGNATURE: *Alan P Booth*      TELEPHONE: **3044535636**      DATE: **9-7-10**

TITLE: **President**      FEIN: **55-0719851**      ADDRESS CHANGES TO BE NOTED ABOVE

WHEN RESPONDING TO REQ INSERT NAME AND ADDRESS IN SPACE ABOVE LABELLED 'VENDOR'

## **SCOPE OF CONTRACT**

The purpose of this Contract shall be to supply compact, portable sign stands and highly reflective roll-up signs, as required, to various West Virginia Division of Highways (WVDOH) personnel.

## **COMPACT PORTABLE SIGN STANDS**

All stands supplied shall be approved in accordance with the requirements of the National Cooperative Highway Research Program (NCHRP) Report 350 or the American Association of State Highway and Transportation Officials (AASHTO) Manual for Assessing Safety Hardware (MASH) (latest version) when utilized as described herein.

Compact, portable sign stands shall be capable of holding 36" and 48" diamond roll-up signs a minimum of 12" off the ground.

Manufacturers are responsible for submitting products to potentially be supplied as part of DOH Contracts for testing and evaluation as these products become available and in advance of the advertisement of these Contracts. All potential stands to be bid as part of this Contract shall have been submitted prior to Contract advertisement for reviews to be performed by Traffic Engineering central office staff and select maintenance personnel. Stands that are reviewed and determined to meet the construction, performance, and usability requirements of the WVDOH shall be listed herein, and will be the only stands considered for award as part of bids submitted for this Contract.

**By bidding this Contract, the Vendor agrees to extend to the WVDOH a four (4) year warranty against defects in workmanship, parts, and materials on all stands supplied as part of this Contract.**

## **COMPACT PORTABLE SIGN STANDS – APPROVED PRODUCTS**

The following manufacturer / model stands have been approved for bidding on this Contract. Bids on this portion of this Contract must specify one of the following models as the stand to be supplied to be considered for award:

- Dicke Tool Uniflex 2000 Sign Stand – **Model UF2000** with aluminum legs, single steel spring, and screw-in type universal sign attachment mechanism.
- MDI Economy WindMaster Sign Stand – **Model 4814SSCKHDK** with aluminum legs, single steel spring, and CamLock cam-type universal sign attachment mechanism.
- Eastern Metal-USA Sign - **Model C-902-DDQA** with aluminum legs
- Korman Signs – **Model SS548UCA** with alum legs, universal latching mechanism with large grip handle, and foot release kick plates.



**ALUMINUM SUBSTRATE SIGN AND LARGE ROLL-UP SIGN PORTABLE SIGN STANDS – SPECIFICATIONS**

All stands supplied shall be approved in accordance with the requirements of the National Cooperative Highway Research Program (NCHRP) Report 350 or the American Association of State Highway and Transportation Officials (AASHTO) Manual for Assessing Safety Hardware (MASH) (latest version) when utilized as described herein.

Aluminum substrate sign and large roll-up sign portable sign stands shall be capable of holding 0.080 aluminum 48" diamond signs, 48" octagon signs, 48" triangle signs, 36x60 vertical rectangle signs, 60x30 horizontal rectangle signs, and smaller signs, as well as roll-up signs as large as 60x60 square. The stand shall be designed such that the sign mounting height will be 12 in to 24 in off of the ground.

The stand provided shall include all components necessary for installing each of the signs referenced above. The stand shall feature an adjustable mast, adjustable brackets for rigid signs, and an adjustable roll-up sign bracket. The roll-up sign bracket shall accommodate all of the horizontal rib sizes detailed as part of this Contract.

Manufacturers are responsible for submitting products to potentially be supplied as part of DOH Contracts for testing and evaluation as these products become available and in advance of the advertisement of these Contracts. All potential stands to be bid as part of this Contract shall have been submitted prior to Contract advertisement for reviews to be performed by Traffic Engineering central office staff and select maintenance personnel. Stands that are reviewed and determined to meet the construction, performance, and usability requirements of the WVDOH shall be listed herein, and will be the only stands considered for award as part of bids submitted for this Contract.

**By bidding this Contract, the Vendor agrees to extend to the WVDOH a four (4) year warranty against defects in workmanship, parts, and materials on all stands supplied as part of this Contract.**

**ALUMINUM SUBSTRATE SIGN AND LARGE ROLL-UP SIGN PORTABLE SIGN STANDS – APPROVED PRODUCTS**

The following manufacturer / model stands have been approved for bidding on this Contract. Bids on this portion of this Contract must specify one of the following models as the stand to be supplied to be considered for award:

- Eastern Metal-USA Sign - Model X553DD
- Korman Signs – Model SS548E

**SIGN FABRICATION STANDARDS**

Note, in regards to all references below to the "WVDOH Sign Fabrication Details", these references shall be interpreted as referring to the manual "West Virginia Division of Highways, Sign Fabrication Details, Traffic Engineering Division, September 2005", and all subsequent supplements. This manual may be accessed online at the following address:  
<http://www.transportation.wv.gov/highways/engineering/Manuals/Traffic/SIGNFAB/INDEX.PDF>

**ROLL-UP SIGN SHEETING**

All signs and plaques supplied as part of this Contract shall be manufactured using either 3M Diamond Grade Roll Up Sign Sheeting (Series RS20/RS24) or Reflexite High Performance Series Sheeting, with manufacturer approved Matched Components (inks).

## **ROLL-UP SHEETING SPLICES**

In cases where the splicing of roll-up sign material fabric is required as noted herein, the splice shall be accomplished by the following method:

- The seam shall be continuously "bridged" on the back side of the sign by a 4" (min) wide strip of 18oz Cooley fabric coated with 200mp adhesive.
- The seam shall be stitched on both the front and back faces of the sign.
- The seam shall be bar tacked on both the front and back faces of the sign on each end of the seam.

## **SIGN FABRICATION SPECIFICATIONS**

All signs supplied shall have one or more vertical fiberglass ribs, with at least one along the vertical centerline of the sign, unless specified otherwise.

All vertical, horizontal, or diagonal ribs shall be designed to pivot about a metallic pivot point. The metallic pivot point shall be a low profile 3/8" diameter, zinc plated steel tubular rivet. Ribs shall be separated by zinc plated flat washers to allow collapsing and roll up of the sign. The rivet shall be equal to Allied Tubular Rivet Inc.'s Part No. 6503. The flat washers shall also eliminate any slack in the assembly while still allowing rotation of the cross braces.

All signs shall be furnished with fabric corner pockets that are accurately placed so that when the sign is assembled with the cross bracing the fit maintains a taut professional look that does not bow or sag. The pockets shall be made from a 15 oz./sq.yd. woven fabric with yarn .018 in diameter that consists of approximately 80% P.V.C. and 20% polyester thread, yielding a minimum of 52 total threads per square inch. The material is finished with heat and pressure in such a way to stabilize the fabric against excess stretch and provide adequate seam strength. The ASTM D3787 ball burst strength should be at least 320 lbs.

Pockets must be triangular in shape [or rectangular as required for ribs that require pockets but are not installed in a sign corner forming a 90 degree angle] and consist of 2 independent square pieces that are folded to form an isosceles triangle and sewn together making it 4 ply. The piece that is in contact with the back of the sign shall be either 9x9 or 7x7 (see table below) and the top piece that creates the pocket cavity shall be an 8x8 or 6x6 respectively. The two pieces are sewn together with an exterior grade T-80H cotton warp thread around the perimeter except for an area for the pocket cavity that is 2x4-1/4 and 2x2-3/4 in the center of the triangle. All thread shall be orange in color for orange background signs and white in color for all other signs. Two vertical 5/8" long bar tacks are to be sewn at the rib entry and one at the pressure point at the end of the pocket using T-40 polyester/cotton corespun thread. The pocket is sewn to the sign following a path around its perimeter with the T-80H thread providing distribution of the rib tension over a significant area instead of along the corner-to-corner centerline. The edges of the pocket cavity must be parallel to the corner-to-corner axis of the cross braces and the end of the pocket that makes contact with the brace tip must be perpendicular to that axis. Detail drawings are provided below for the 9x9 pocket (Type B) and the 7x7 pocket (Type A).

Rectangular pockets, when required, shall be 2-1/2" wide mesh (see table below), and of sufficient length when folded to form 4 layers of mesh at least 3/4" back from the end of the cross brace and 3 layers on the remaining part of the pocket. The bar tacks shall be 1/2" long minimum up to 5/8" long. Pockets shall be orange in color for orange background signs and white in color for all other signs.

Pockets shall be installed as close as possible to the edges of the sign. The sewing operation, including but not limited to thread size, equipment, etc. shall be determined and accomplished to not damage the reflective sheeting while providing a product conforming to these specifications.

SIGN SHAPE	POCKET SIZE
48" Diamond	9x9 (Pocket B)
36" Diamond	7x7 (Pocket A)
60x60 Square	9x9 (Pocket B)
48x48 Square	9x9 (Pocket B)
36x48 vert rectangle	9x9 (Pocket B)
36x60 vert rectangle	9x9 (Pocket B)
24x30 vert rectangle	7x7 (Pocket A)
60x30 horiz rectangle	9x9 (Pocket B)
48x36 horiz rectangle	7x7 (Pocket A)
48x30 horiz rectangle	7x7 (Pocket A)
48x24 horiz rectangle	7x7 (Pocket A)
30x24 horiz rectangle	7x7 (Pocket A)
30x18 horiz rectangle	7x7 (Pocket A)
36" octagon	2-1/2W x 2-1/4L rectangular (horizontal rib) 2-1/2W x 3-1/4L rectangular (vertical ribs)
48" octagon	2-1/2W x 2-1/4L rectangular (horizontal rib) 2-1/2W x 3-1/4L rectangular (vertical ribs)
36" triangle	2-1/2W x 2-1/4L rectangular
48" triangle	2-1/2W x 3-1/4L rectangular

With the exception of octagonal (Stop) and triangular (Yield) signs, two pieces of Hook & Loop (H&L) shall be sewn on all non-diamond signs for attachment of the sign to the vertical rib. The H&L shall have sufficient length to encircle the vertical rib and hold the sign taut to the rib. The locations of the two pieces of H&L shall be 2" from the bottom and 2" from the top of the sign to the beginning edge of the H&L and on the sign's horizontal center. Half of the length shall be hook type and other half shall be loop type with the two types reversed and sewn together and then to the back of the sign.



For the vertical rib of triangular (Yield) signs, only the bottom piece of H&L described above shall be required. In addition, a 3" long piece of H&L shall be attached via adhesive to the side of the rib not touching the back of the sign to allow the rib to be held in position via attachment to the H&L attached to the back sign face.

All vertical ribs of octagonal (stop) signs shall be installed in rectangular pockets. The rectangular pockets for the horizontal rib shall be installed directly under the outside vertical ribs of the sign.

## CLOTH CORNER POCKET DESIGNS

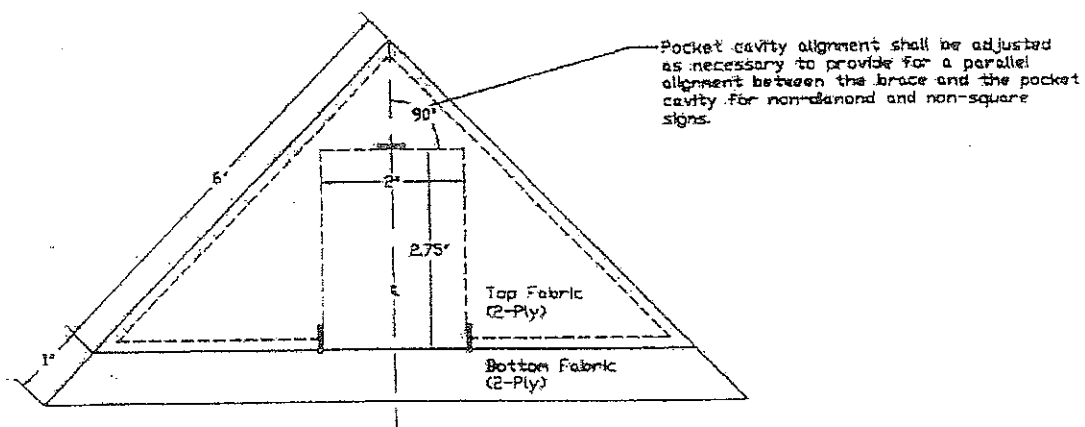
### TYPE A POCKET DESIGN



 5/8" Bartacks  
 Stitching

### TYPE B POCKET DESIGN

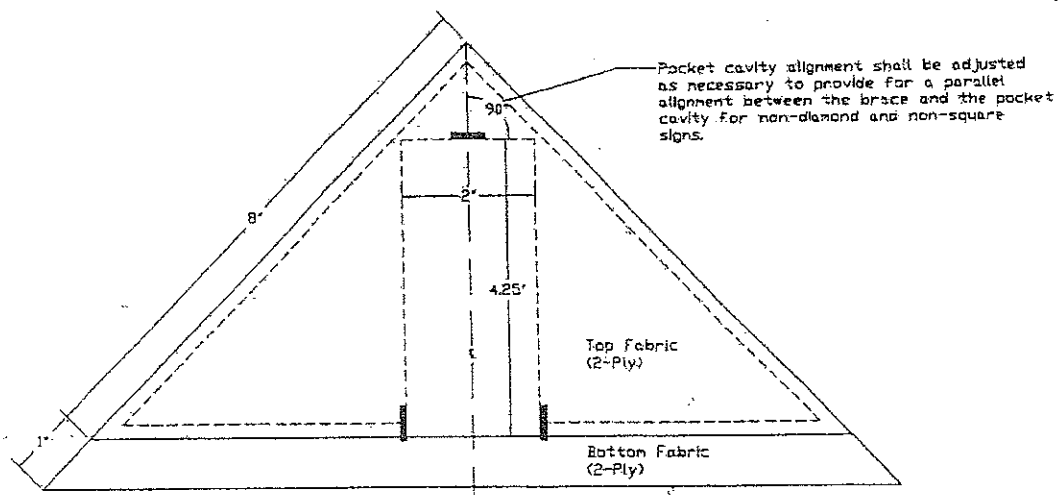

When specified (see bid item listing), two 18" x 18" non-reflective fluorescent orange vinyl flags shall be permanently attached to the top of the vertical rib that is along the vertical centerline of the sign. The system for deploying the flags shall be a good quality, long lasting, reliable system. All metal parts of the system shall be stainless steel, electro-deposit zinc coated steel, hot-dip galvanized steel, or powder coated steel. Flag staffs should be fiberglass, similar to the sign ribs, and have a minimum section modulus equal to that of a 1/8" thick x 1" wide rib (0.002604 in ^ 3). The staffs shall be sufficiently long enough to hold the flags completely above the sign face. No hand tightening of any components shall be required to hold the flags in the deployed position. When deployed, the two flags shall extend symmetrically (about the vertical centerline) up and out from their mounting point along the vertical rib, with the flags held in position completely above the sign face, and with each staff at an angle of 30 to 60 degrees from the vertical centerline of the sign. Staff mounting and deployment systems shall be subject to review and approval.

For particular signs (see bid item listing) and all overlay plaques requiring H&L strips for temporary overlay attachment, the hook ("coarse") side of the H&L shall be attached to the sign faces. The loop ("fuzzy") side of the H&L shall be attached to the back face of the overlays.

All signs must present a finished, professional look to the motorist with no sagging of the sign material. Signs shall include anti-kite H&L loops attached to the back faces of the signs and to be connected around the ribs of the signs. The sign manufacturer shall determine appropriate locations for anti-kite H&L strips. An additional length of H&L material shall be fastened near the vertical center of one of the horizontal end points on each sign, and shall be oriented such that when the sign is rolled up on the vertical rib the H&L material will encircle the sign and hold it in the rolled up storing position.

All roll-up signs shall have a permanent sticker affixed to the non-reflective face with the wording "PROPERTY OF WVDOH" in 1/2" minimum legend size.

Identification shall be printed in the margin for convenient indication of the sign message when the sign is rolled up for storage.

**By bidding this Contract, the Vendor agrees to extend to the WVDOH a one (1) year warranty against defects in workmanship, parts, and materials on all signs supplied as part of this Contract. Sheeting performance failure shall be covered by the approved sheeting manufacturer's warranty provided to the WVDOH, as applicable.**

**ADDITIONAL SPECIFICATIONS FOR BID ITEM 3**

Signs supplied as part of Bid Item 3 shall be per the WVDOH Sign Fabrication Details, fabrication number R1-1, 36", and shall be octagonal in shape. Rib sizes, rib locations, rib lengths, corner pocket locations, and rotation point location shall be in substantial conformance as shown in the attached drawing "36" OCTAGON – CORNER POCKET AND RIB CONFIGURATION".

**ADDITIONAL SPECIFICATIONS FOR BID ITEM 4**

Signs supplied as part of Bid Item 4 shall be per the WVDOH Sign Fabrication Details, fabrication number R1-1, 48", and shall be octagonal in shape. Rib sizes, rib locations, rib lengths, corner pocket locations, and rotation point location shall be in substantial conformance as shown in the attached drawing "48" OCTAGON – CORNER POCKET AND RIB CONFIGURATION".

**ADDITIONAL SPECIFICATIONS FOR BID ITEM 5**

Signs supplied as part of Bid Item 5 shall be per the WVDOH Sign Fabrication Details, fabrication number W3-1M, 36". An orange background shall be used. The symbol may be glued or sewn onto the sign face separately. Rib sizes, rib locations, rib lengths, corner pocket locations, and rotation point location shall be in substantial conformance as shown in the attached drawing "36" DIAMOND – CORNER POCKET AND RIB CONFIGURATION".

### **ADDITIONAL SPECIFICATIONS FOR BID ITEM 6**

Signs supplied as part of Bid Item 6 shall be per the WVDOH Sign Fabrication Details, fabrication number W3-1M, 48". An orange background shall be used. The symbol may be glued or sewn onto the sign face separately. Rib sizes, rib locations, rib lengths, corner pocket locations, and rotation point location shall be in substantial conformance as shown in the attached drawing "48" **DIAMOND – CORNER POCKET AND RIB CONFIGURATION**".

### **ADDITIONAL SPECIFICATIONS FOR BID ITEM 7**

Signs supplied as part of Bid Item 7 shall be per the WVDOH Sign Fabrication Details, fabrication number R1-2, 36", and shall be triangular in shape. Rib sizes, rib locations, rib lengths, corner pocket locations, and rotation point location shall be in substantial conformance as shown in the attached drawing "36" **TRIANGLE – CORNER POCKET AND RIB CONFIGURATION**".

### **ADDITIONAL SPECIFICATIONS FOR BID ITEM 8**

Signs supplied as part of Bid Item 8 shall be per the WVDOH Sign Fabrication Details, fabrication number R1-2, 48", and shall be triangular in shape. Rib sizes, rib locations, rib lengths, corner pocket locations, and rotation point location shall be in substantial conformance as shown in the attached drawing "48" **TRIANGLE – CORNER POCKET AND RIB CONFIGURATION**".

### **ADDITIONAL SPECIFICATIONS FOR BID ITEM 9**

Signs supplied as part of Bid Item 9 shall be per the WVDOH Sign Fabrication Details, fabrication number W3-2M, 36". An orange background shall be used. The symbol may be glued or sewn onto the sign face separately. Rib sizes, rib locations, rib lengths, corner pocket locations, and rotation point location shall be in substantial conformance as shown in the attached drawing "36" **DIAMOND – CORNER POCKET AND RIB CONFIGURATION**".

### **ADDITIONAL SPECIFICATIONS FOR BID ITEM 10**

Signs supplied as part of Bid Item 10 shall be per the WVDOH Sign Fabrication Details, fabrication number W3-2M, 48". An orange background shall be used. The symbol may be glued or sewn onto the sign face separately. Rib sizes, rib locations, rib lengths, corner pocket locations, and rotation point location shall be in substantial conformance as shown in the attached drawing "48" **DIAMOND – CORNER POCKET AND RIB CONFIGURATION**".

### **ADDITIONAL SPECIFICATIONS FOR BID ITEM 11**

Signs supplied as part of Bid Item 11 shall be per the attached drawing "**BID ITEM 11 MODIFIED STANDARD DETAIL**". Overall size shall be 36"x60". All text shall be black. The background above the horizontal border shall be orange. The background below the horizontal border shall be white. The seam between the upper (orange background) and bottom (white background) portions of the sign shall be sewn along the black border in the manner specified above in the **ROLL-UP SHEETING SPLICES** section. No numerals shall be screened onto the sign face. 2 ea. 28" long x 1" (min) wide pieces of H&L shall be glued or sewn onto the sign face, as shown on the attached modified standard detail, to facilitate the attachment of the interchangeable numerals to be supplied as part of Bid Item 12. Rib sizes, rib locations, rib lengths, corner pocket locations, and rotation point location shall be in substantial conformance as shown in the attached drawing "**36X60 VERTICAL RECTANGLE – CORNER POCKET AND RIB CONFIGURATION**".

### **ADDITIONAL SPECIFICATIONS FOR BID ITEM 12**

Items supplied as part of Bid Item 12 shall be individual numeral plaques intended to be attached to the face of signs supplied under Bid Item 11. The numeral portions of the plaques shall be black, and the background portions shall be white. The overall size of each individual plaque shall be 17" tall x 14" wide. Numerals shall be 15" Series E, and shall be centered vertically and horizontally in each plaque. 2 ea. 14" long x 1" (min) wide pieces of H&L shall be glued or sewn onto the back face of each plaque, with 1 ea. of the pieces along the top and bottom edges of the plaque, and with the outside edge of each piece along the outside edge of the plaque. Orders will specify the quantity of each individual numeral to be supplied.

### **ADDITIONAL SPECIFICATIONS FOR BID ITEM 13**

Signs supplied as part of Bid Item 13 shall be per the attached drawing "**BID ITEM 13 MODIFIED STANDARD DETAIL**". The text, arrow shaft, and border portions of the sign shall be black, and the background portion shall be white. 4 ea. 8" long x 1" (min) wide pieces of white H&L shall be glued or sewn onto the sign face, as shown on the attached detail, to facilitate the attachment of the included detachable arrow head as described below. Rib sizes, rib locations, rib lengths, corner pocket locations, and rotation point location shall be in substantial conformance as shown in the attached drawing "**48X24 HORIZONTAL RECTANGLE – CORNER POCKET AND RIB CONFIGURATION**".

With each of the signs supplied as part of this bid item, 1 ea. separate arrow head plaque, intended to be attached to the face of the sign, shall be supplied as detailed on the above referenced modified standard detail. 2 ea. 8" long x 1" (min) wide pieces of H&L shall be glued or sewn onto the back face of each plaque, with 1 ea. of the pieces along the top and bottom edges of the plaque, and with the outside edge of each piece along the outside edge of the plaque. The arrow head and shaft portions of the plaque shall be black, and the background portion shall be white.

### **ADDITIONAL SPECIFICATIONS FOR BID ITEM 14**

Signs supplied as part of Bid Item 14 shall be per the WVDOH Sign Fabrication Details, fabrication number R4-7B, 24"X30". Rib sizes, rib locations, rib lengths, corner pocket locations, and rotation point location shall be in substantial conformance as shown in the attached drawing "**24X30 VERTICAL RECTANGLE – CORNER POCKET AND RIB CONFIGURATION**".

### **ADDITIONAL SPECIFICATIONS FOR BID ITEM 15**

Signs supplied as part of Bid Item 15 shall be per the WVDOH Sign Fabrication Details, fabrication number R4-7B, 36"X48". Rib sizes, rib locations, rib lengths, corner pocket locations, and rotation point location shall be in substantial conformance as shown in the attached drawing "**36X48 VERTICAL RECTANGLE – CORNER POCKET AND RIB CONFIGURATION**".

### **ADDITIONAL SPECIFICATIONS FOR BID ITEM 16**

Signs supplied as part of Bid Item 16 shall be per the WVDOH Sign Fabrication Details, fabrication number R9-9. Rib sizes, rib locations, rib lengths, corner pocket locations, and rotation point location shall be in substantial conformance as shown in the attached drawing "**30X18 HORIZONTAL RECTANGLE – CORNER POCKET AND RIB CONFIGURATION**".

### **ADDITIONAL SPECIFICATIONS FOR BID ITEM 17**

Signs supplied as part of Bid Item 17 shall be per the attached drawing "**BID ITEM 17 MODIFIED STANDARD DETAIL**". The text and border portions of the sign shall be black, and the background portion shall be white. 2 ea. 39" long x 1" wide pieces of white H&L shall be glued or sewn onto the sign face, as shown on the attached modified standard detail, to facilitate the attachment of the interchangeable "BRIDGE" and "RAMP" plaques to be supplied as part of Bid Item 18. Rib sizes, rib locations, rib lengths, corner pocket locations, and rotation point location shall be in substantial conformance as shown in the attached drawing "**48x30 HORIZONTAL RECTANGLE – CORNER POCKET AND RIB CONFIGURATION**".

### **ADDITIONAL SPECIFICATIONS FOR BID ITEM 18**

Items supplied as part of Bid Item 18 shall be individual message "BRIDGE" and "RAMP" plaques intended to be attached to the face of signs supplied under Bid Item 17. The text portions of the plaques shall be black, and the background portions shall be white. The overall size of each individual plaque shall be 10" tall x 39" wide. Text shall be 8" Series D, and shall be centered vertically and horizontally in each plaque. 2 ea. 39" long x 1" wide pieces of H&L shall be glued or sewn onto the back face of each plaque, with 1 ea. of the pieces along the top and bottom edges of the plaque, and with the outside edge of each piece along the outside edge of the plaque. Orders will specify the quantity of each individual message ("BRIDGE" and "RAMP") to be supplied.

### **ADDITIONAL SPECIFICATIONS FOR BID ITEM 19**

Signs supplied as part of Bid Item 19 shall be per the attached drawing "**BID ITEM 19 MODIFIED STANDARD DETAIL**". The text and border portions of the sign shall be black, and the background portion shall be white. No numerals shall be screened onto the sign face. 2 ea. 10" long x 1" (min) wide pieces of white H&L shall be glued or sewn onto the sign face, as shown on the attached modified standard detail, to facilitate the attachment of the interchangeable numeral plaques to be supplied as part of Bid Item 20. Rib sizes, rib locations, rib lengths, corner pocket locations, and rotation point location shall be in substantial conformance as shown in the attached drawing "**60x30 HORIZONTAL RECTANGLE – CORNER POCKET AND RIB CONFIGURATION**".

### **ADDITIONAL SPECIFICATIONS FOR BID ITEM 20**

Items supplied as part of Bid Item 20 shall be individual numeral plaques intended to be attached to the face of signs supplied under Bid Item 19. The numeral portions of the plaques shall be black, and the background portions shall be white. The overall size of each individual plaque shall be 7" tall x 5" wide. Numerals shall be 5" Series C, and shall be centered vertically and horizontally in each plaque. 2 ea. 5" long x 1" (min) wide pieces of H&L shall be glued or sewn onto the back face of each plaque, with 1 ea. of the pieces along the top and bottom edges of the plaque, and with the outside edge of each piece along the outside edge of the plaque. Orders will specify the quantity of each individual numeral to be supplied.

### **ADDITIONAL SPECIFICATIONS FOR BID ITEM 21**

Signs supplied as part of Bid Item 21 shall be per the WVDOH Sign Fabrication Details, fabrication number R11-4. Rib sizes, rib locations, rib lengths, corner pocket locations, and rotation point location shall be in substantial conformance as shown in the attached drawing "**60x30 HORIZONTAL RECTANGLE – CORNER POCKET AND RIB CONFIGURATION**".

### **ADDITIONAL SPECIFICATIONS FOR BID ITEM 22**

Signs supplied as part of Bid Item 22 shall be per the attached drawing "**BID ITEM 22 MODIFIED STANDARD DETAIL**". The text and border portions of the sign shall be black, and the background portion shall be orange. 2 ea. 40" long x 1" (min) wide pieces of H&L shall be glued or sewn onto the sign face, as shown on the attached modified standard detail, to facilitate the attachment of the interchangeable message plaques to be supplied as part of Bid Item 23. Rib sizes, rib locations, rib lengths, corner pocket locations, and rotation point location shall be in substantial conformance as shown in the attached drawing "**48x36 HORIZONTAL RECTANGLE – CORNER POCKET AND RIB CONFIGURATION**".



### **ADDITIONAL SPECIFICATIONS FOR BID ITEM 23**

Items supplied as part of Bid Item 23 shall be individual message plaques intended to be attached to the face of signs supplied under Bid Item 22. The text portions of the plaques shall be black, and the background portions shall be orange. The overall size of each individual plaque shall be 16" tall x 40" wide. Text shall be 8" Series D, and shall be centered vertically and horizontally in each plaque. 2 ea. 40" long x 1" (min) wide pieces of H&L shall be glued or sewn onto the back face of each plaque, with 1 ea. of the pieces along the top and bottom edges of the plaque, and with the outside edge of each piece along the outside edge of the plaque. Orders will specify the quantity of each individual message ("OPEN" and "CLOSED") to be supplied.

### **ADDITIONAL SPECIFICATIONS FOR BID ITEM 24**

Signs supplied as part of Bid Item 24 shall be per the WVDOH Sign Fabrication Details, fabrication number W22-11. The text and border portions of the sign shall be black, and the background portion of the sign shall be orange. One vertical seam located 12" from the left (front face) edge of the sign will be allowed. The seam shall be manufactured in the manner specified above in the **ROLL-UP SHEETING SPLICES** section. Rib sizes, rib locations, rib lengths, corner pocket locations, and rotation point location shall be in substantial conformance as shown in the attached drawing "**60X60 SQUARE – CORNER POCKET AND RIB CONFIGURATION**".

### **ADDITIONAL SPECIFICATIONS FOR BID ITEM 25**

Signs supplied as part of Bid Item 25 shall be per the attached drawing "**BID ITEM 25 MODIFIED STANDARD DETAIL**". The text and border portions of the sign shall be black, and the background portion shall be orange. 4 ea. 5" long x ½" wide pieces of H&L shall be glued or sewn onto the sign face, as shown on the attached modified standard detail, to facilitate the attachment of the arrow overlay plaque as described below. Rib sizes, rib locations, rib lengths, corner pocket locations, and rotation point location shall be in substantial conformance as shown in the attached drawing "**30X24 HORIZONTAL RECTANGLE – CORNER POCKET AND RIB CONFIGURATION**".

With each of the signs supplied as part of this bid item, 1 ea. separate arrow head plaque, intended to be attached to the face of the sign as detailed on the above referenced modified standard detail, shall be supplied. 8 ea. 5" long x ½" wide pieces of H&L shall be glued or sewn onto the back face of each plaque as shown on the modified standard detail. The arrow head and shaft portions of the plaque shall be black, and the background portion shall be orange.

### **ADDITIONAL SPECIFICATIONS FOR BID ITEM 26**

Signs supplied as part of Bid Item 26 shall be per the attached drawing "**BID ITEM 26 MODIFIED STANDARD DETAIL**". The text and border portions of the sign shall be black, and the background portion shall be orange. "DETOUR" text size shall be 7" Series D. Border shall be 1.25". Margin shall be 0.75". Corner Radius shall be 3". 2 ea. 41-1/2" long x 1" (min) wide pieces of orange H&L shall be glued or sewn onto the sign face, as shown on the attached modified standard detail, to facilitate the attachment of the interchangeable overlay plaques to be supplied as part of Bid Items 27 and 28. 4 ea. 6" long x ½" wide pieces of H&L shall be glued or sewn onto the sign face, as shown on the attached modified standard detail, to facilitate the attachment of the arrow overlay plaque as described below. Rib sizes, rib locations, rib lengths, corner pocket locations, and rotation point location shall be in substantial conformance as shown in the attached drawing "**48x48 SQUARE – CORNER POCKET AND RIB CONFIGURATION**".

With each of the signs supplied as part of this bid item, 1 ea. separate arrow head plaque, as detailed on the above referenced modified standard detail, intended to be attached to the face of the sign shall be supplied. 8 ea. 6" long x ½" wide pieces of H&L shall be glued or sewn onto the back face of each plaque as shown on the modified standard detail. The arrow head and shaft portions of the plaque shall be black, and the background portion shall be orange.

### **ADDITIONAL SPECIFICATIONS FOR BID ITEM 27**

Items supplied as part of Bid Item 27 shall be individual route plaques intended to be attached to the face of signs supplied under Bid Item 26. The text portions of the plaques shall be black, and the background portions shall be orange. The overall size of each individual plaque shall be 9" tall x 28" wide. Text shall be 8" Series D, or, if necessary, 8" Series C as required for 3 digit routes. Text shall be centered vertically and horizontally in each plaque. Format of text shall be "Route Classification"-Hyphen-"Route Number" (i.e. "US-119", "WV-2", "I-79", etc.). 2 ea. 28" long x 1" (min) wide pieces of H&L shall be glued or sewn onto the back face of each plaque, with 1 ea. of the pieces along the top and bottom edges of the plaque, and with the outside edge of each piece along the outside edge of the plaque. Orders will specify the quantity of each individual route plaque to be supplied.

### **ADDITIONAL SPECIFICATIONS FOR BID ITEM 28**

Items supplied as part of Bid Item 28 shall be individual cardinal direction plaques intended to be attached to the face of signs supplied under Bid Item 26. The text portions of the plaques shall be black, and the background portions shall be orange. The overall size of each individual plaque shall be 9" tall x 7" wide. Text shall be 8" Series D. Text shall be centered vertically and horizontally in each plaque. 2 ea. 7" long x 1" (min) wide pieces of H&L shall be glued or sewn onto the back face of each plaque, with 1 ea. of the pieces along the top and bottom edges of the plaque, and with the outside edge of each piece along the outside edge of the plaque. Orders will specify the quantity of each individual plaque ("N", "S", "E", and "W") to be supplied.

### **ADDITIONAL SPECIFICATIONS FOR BID ITEM 29**

Items supplied as part of Bid Item 29 shall be standard message (as shown in the WVDOH Sign Fabrication Details) orange and black 48"x48" diamond shaped construction zone warning signs. The text portions of the signs shall be black, and the background portions shall be orange. Rib sizes, rib locations, rib lengths, corner pocket locations, and rotation point location shall be in substantial conformance as shown in the attached drawing **"48" DIAMOND – CORNER POCKET AND RIB CONFIGURATION"**. Orders will specify the quantity of each fabrication number to be supplied.

### **ADDITIONAL SPECIFICATIONS FOR BID ITEM 30**

Items supplied as part of Bid Item 30 shall be standard message (as shown in the WVDOH Sign Fabrication Details) orange and black 48"x48" diamond shaped construction zone warning signs, with the addition of 2 ea. 18" x 18" non-reflective fluorescent orange vinyl flags, as specified above. The text portions of the signs shall be black, and the background portions shall be orange. Rib sizes, rib locations, rib lengths, corner pocket locations, and rotation point location shall be in substantial conformance as shown in the attached drawing **"48" DIAMOND – CORNER POCKET AND RIB CONFIGURATION"**. Orders will specify the quantity of each fabrication number to be supplied.

### **ADDITIONAL SPECIFICATIONS FOR BID ITEM 31**

Items supplied as part of Bid Item 31 shall be standard message (as shown in the WVDOH Sign Fabrication Details) orange and black 36"x36" diamond shaped construction zone warning signs. The text portions of the signs shall be black, and the background portions shall be orange. Rib sizes, rib locations, rib lengths, corner pocket locations, and rotation point location shall be in substantial conformance as shown in the attached drawing **"36" DIAMOND – CORNER POCKET AND RIB CONFIGURATION"**. Orders will specify the quantity of each fabrication number to be supplied.

### **ADDITIONAL SPECIFICATIONS FOR BID ITEM 32**

Items supplied as part of Bid Item 32 shall be standard message (as shown in the WVDOH Sign Fabrication Details) orange and black 36"x36" diamond shaped construction zone warning signs, with the addition of 2 ea. 18" x 18" non-reflective fluorescent orange vinyl flags, as specified above. The text portions of the signs shall be black, and the background portions shall be orange. Rib sizes, rib locations, rib lengths, corner pocket locations, and rotation point location shall be in substantial conformance as shown in the attached drawing "**36" DIAMOND – CORNER POCKET AND RIB CONFIGURATION**". Orders will specify the quantity of each fabrication number to be supplied.

### **ADDITIONAL SPECIFICATIONS FOR BID ITEM 33**

Items supplied as part of Bid Item 33 shall be standard message (as shown in the WVDOH Sign Fabrication Details) orange and black 48"x48" diamond shaped construction zone warning signs with the addition of 2 ea. 28" long x 1/2" wide and/or 2 ea. 23" long x 1/2" wide orange H&L strips to be glued or sewn onto the sign face. The H&L strips shall be installed horizontally and parallel to one another, with the measured distance between the outside edges of the strips to be 8". The mid-point along (14" and/or 11-1/2") and between (4") the strips shall be centered vertically and horizontally about the portion of text in the sign specified. The text portions of the signs shall be black, and the background portions shall be orange. Rib sizes, rib locations, rib lengths, corner pocket locations, and rotation point location shall be in substantial conformance as shown in the attached drawing "**48" DIAMOND – CORNER POCKET AND RIB CONFIGURATION**".

For further guidance, included as part of this Contract is a listing of individual signs with which supplemental overlay plaques are frequently used. For each sign with multiple possible messages through the use of overlay plaques, this listing specifies a "base" sign message. Each sign ordered with H&L in order to incorporate overlay plaques shall be manufactured with the "base" sign message as the permanent message on the sign. All 48" signs ordered which may potentially be altered with overlay plaques shall be ordered with H&L strips under this Item number or Item number 34.

Orders will specify the quantity of each fabrication number to be supplied.

### **ADDITIONAL SPECIFICATIONS FOR BID ITEM 34**

Items supplied as part of Bid Item 34 shall be standard message (as shown in the WVDOH Sign Fabrication Details) orange and black 48"x48" diamond shaped construction zone warning signs, with the addition of 2 ea. 28" long x 1/2" wide and/or 2 ea. 23" long x 1/2" wide orange H&L strips to be glued or sewn onto the sign face, and 2 ea. 18" x 18" non-reflective fluorescent orange vinyl flags, as specified above. The H&L strips shall be installed horizontally and parallel to one another, with the measured distance between the outside edges of the strips to be 8". The mid-point along (14" and/or 11-1/2") and between (4") the strips shall be centered vertically and horizontally about the portion of text in the sign specified. The text portions of the signs shall be black, and the background portions shall be orange. Rib sizes, rib locations, rib lengths, corner pocket locations, and rotation point location shall be in substantial conformance as shown in the attached drawing "**48" DIAMOND – CORNER POCKET AND RIB CONFIGURATION**".

For further guidance, included as part of this Contract is a listing of individual signs with which supplemental overlay plaques are frequently used. For each sign with multiple possible messages through the use of overlay plaques, this listing specifies a "base" sign message. Each sign ordered with H&L in order to incorporate overlay plaques shall be manufactured with the "base" sign message as the permanent message on the sign. All 48" signs ordered which may potentially be altered with overlay plaques shall be ordered with H&L strips under this Item number or Item number 33.

Orders will specify the quantity of each fabrication number to be supplied.

### **ADDITIONAL SPECIFICATIONS FOR BID ITEM 35**

Items supplied as part of Bid Item 35 shall be standard message (as shown in the WVDOH Sign Fabrication Details) orange and black 36"x36" diamond shaped construction zone warning signs with the addition of 2 to 4 ea. 21" long x 1/2" wide orange H&L strips to be glued or sewn onto the sign face. The H&L strips shall be installed horizontally and parallel to one another, with the measured distance between the outside edges of the strips to be 6". The mid-point along (10-1/2") and between (3") the strips shall be centered vertically and horizontally about the portion of text in the sign specified. The text portions of the signs shall be black, and the background portions shall be orange. Rib sizes, rib locations, rib lengths, corner pocket locations, and rotation point location shall be in substantial conformance as shown in the attached drawing "**36" DIAMOND – CORNER POCKET AND RIB CONFIGURATION**".

For further guidance, included as part of this Contract is a listing of individual signs with which supplemental overlay plaques are frequently used. For each sign with multiple possible messages through the use of overlay plaques, this listing specifies a "base" sign message. Each sign ordered with H&L in order to incorporate overlay plaques shall be manufactured with the "base" sign message as the permanent message on the sign. All 36" signs ordered which may potentially be altered with overlay plaques shall be ordered with H&L strips under this Item number or Item number 36.

Orders will specify the quantity of each fabrication number to be supplied.

### **ADDITIONAL SPECIFICATIONS FOR BID ITEM 36**

Items supplied as part of Bid Item 36 shall be standard message (as shown in the WVDOH Sign Fabrication Details) orange and black 36"x36" diamond shaped construction zone warning signs with the addition of 2 to 4 ea. 21" long x 1/2" wide orange H&L strips to be glued or sewn onto the sign face, and 2 ea. 18" x 18" non-reflective fluorescent orange vinyl flags, as specified above. The H&L strips shall be installed horizontally and parallel to one another, with the measured distance between the outside edges of the strips to be 6". The mid-point along (10-1/2") and between (3") the strips shall be centered vertically and horizontally about the portion of text in the sign specified. The text portions of the signs shall be black, and the background portions shall be orange. Rib sizes, rib locations, rib lengths, corner pocket locations, and rotation point location shall be in substantial conformance as shown in the attached drawing "**36" DIAMOND – CORNER POCKET AND RIB CONFIGURATION**".

For further guidance, included as part of this Contract is a listing of individual signs with which supplemental overlay plaques are frequently used. For each sign with multiple possible messages through the use of overlay plaques, this listing specifies a "base" sign message. Each sign ordered with H&L in order to incorporate overlay plaques shall be manufactured with the "base" sign message as the permanent message on the sign. All 36" signs ordered which may potentially be altered with overlay plaques shall be ordered with H&L strips under this Item number or Item number 36.

Orders will specify the quantity of each fabrication number to be supplied.

### **ADDITIONAL SPECIFICATIONS FOR BID ITEM 37**

Items supplied as part of Bid Item 37 shall be individual message plaques intended to be attached to the face of signs supplied under Bid Items 33 and 34. The text portions of the plaques shall be black, and the background portions shall be orange. The overall size of each individual plaque, with the exception of "LEFT" and "CENTER" plaques, shall be 8" tall x 28" wide. "LEFT" and "CENTER" plaques shall be 8" tall x 23" wide. Text shall be 7" Series C. Text shall be centered vertically and horizontally in each plaque. 2 ea. 28" (23" where a "LEFT" or "CENTER" plaque may be attached) long x 1/2" wide pieces of H&L shall be glued or sewn onto the back face of each plaque, with 1 ea. of the pieces along the top and bottom edges of the plaque, and with the outside edge of each piece along the outside edge of the plaque. Orders will specify the quantity of each individual plaque to be supplied.

Note, "AHEAD" plaques shall not be manufactured or supplied under this Item number.

### **ADDITIONAL SPECIFICATIONS FOR BID ITEM 38**

Items supplied as part of Bid Item 38 shall be individual message plaques intended to be attached to the face of signs supplied under Bid Items 35 and 36. The text portions of the plaques shall be black, and the background portions shall be orange. The overall size of each individual plaque shall be 6" tall x 21" wide. Text shall be 5" Series C. Text shall be centered vertically and horizontally in each plaque. 2 ea. 21" long x ½" wide pieces of H&L shall be glued or sewn onto the back face of each plaque, with 1 ea. of the pieces along the top and bottom edges of the plaque, and with the outside edge of each piece along the outside edge of the plaque. Orders will specify the quantity of each individual plaque to be supplied.

### **ADDITIONAL SPECS FOR BID ITEM 39**

Signs supplied as part of Bid Item 39 shall be per the WVDOH Sign Fabrication Details, fabrication number G20-2, 18"x36". Rib sizes, rib locations, rib lengths, corner pocket locations, and rotation point location shall be in substantial conformance as shown in the attached drawing "18x36 HORIZONTAL RECTANGLE – CORNER POCKET AND RIB CONFIGURATION".

### **PRODUCT COMPLIANCE CHECKLIST FORM**

The Vendor shall complete the Product Compliance Checklist Forms included as part of this Contract in their entirety. Bids with these forms uncompleted will be rejected. This requirement does not apply to portions of the Contract that the Vendor chooses to not bid, and as allowed for as noted on the Product Compliance Checklist Forms (Item #1, Item #2, and/or Items 3 through 39).

### **SHEETING MANUFACTURER CERTIFICATION**

In order to insure that the warranty required by the WVDOH to be provided by the sheeting manufacturer is in effect and is not in question, the Vendor shall be required to submit to the WVDOH a letter certifying that the sign manufacturer is certified by the sheeting manufacturer for manufacturing traffic signs using the sheeting manufacturer's material. This letter shall be addressed from the sheeting manufacturer to the sign manufacturer. This letter should be submitted with the Vendor's bid package. If this letter is not submitted with a Vendor's bid package that is being considered for award as part of this Contract, the WVDOH will contact the Vendor to request that this letter be submitted. The Vendor will have five (5) business days from this point to submit this letter to the WVDOH; otherwise, the Vendor's bid will be disqualified.

## **BID SCHEDULE FOR AWARD**

- Item #1 will be evaluated, and if need be, awarded independently.
- Item #2 will be evaluated, and if need be, awarded independently.
- The entire Sign portion (Item Numbers 3 through 39) will be evaluated as a whole, and will be awarded as such. If need be, these Items will be awarded independently of Bid Items 1 and 2. All Vendors wishing to be considered for award of the Sign portion of the Contract must provide a bid price for all Items within this Section.

The WVDOH's preference is to minimize the number of Vendor's to which this Contract is split and awarded to. Therefore, if not required by necessity and based on estimated cost alone, this Contract will only be split between two Vendors if the estimated overall savings to the WVDOH is 10% or more of the estimated overall cost associated with awarding to only one Vendor. Furthermore, this Contract will only be split between three Vendors if the estimated overall savings to the WVDOH is 10% or more of the estimated overall cost associated with awarding to only two Vendors.

Vendors are to submit pricing for each Item they are bidding, regardless of the presence of a value in the Estimated Quantity column.

For Items without a value in the Estimated Quantity column, the Vendor is to submit their price for one (1) unit Item. The Total Cost column should be left blank in this case.

In determining the Vendor's total bid for the Sign portion of the Contract for bid evaluation purposes, the figures in the Total Cost column associated with Items with an estimated quantity indicated will be totaled. Pricing for Items without a value in the Estimated Quantity column will not be used in determining the award of the Contract.

The estimated quantities shown on the Bid Schedule are estimated quantities only. Actual quantities ordered may be more or less than those shown.

## **LOW BIDDER SAMPLE SIGN SUBMITTAL**

As part of the review of bids for this Contract, the Division may, at its' discretion, require bidders being considered for award as part of the sign portion of the Contract to submit sample signs for review. If required, the bidder(s) will be required to submit one or more of the following signs:

- 1 ea. Item # 3
- 1 ea. Item # 11
- 2 ea. Item #12 (1 ea. "4", 1 ea. "5")
- 1 ea. Item # 34, Fab # W20-5A, H&L positioned to allow "RIGHT" and "1500 FT" to be covered.
- 2 ea. Item # 37 (1 ea. "LEFT", 1 ea. "500 FT")

The bidder(s) will be required to submit the signs requested within ten (10) working days of notification. Failure to supply the requested signs within this time frame may result in the disqualification of the vendor's bid. Samples are to be delivered to the following address:

WVDOH-Traffic Engineering Division  
Traffic Services Complex  
180 Dry Branch Dr.  
Charleston, WV 25306  
ATTN: Ted Whitmore

**DELIVERY**

All materials shall be delivered within forty-five (45) days ARO. Late delivery charges against the vendor may be assessed at a rate of \$120.00 per calendar day after forty-five (45) days ARO.

**MINIMUM ORDERS**

There shall be no minimum order requirement for this contract.

BID ITEM 11 - MODIFIED STANDARD DETAIL

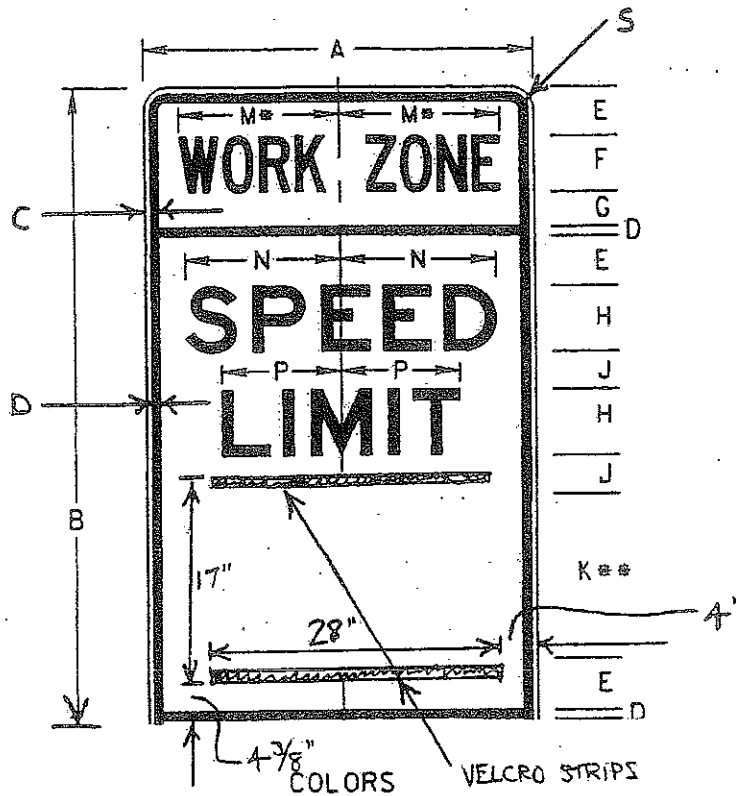

LEGEND - BLACK (NON-REF)  
 TOP BACKGROUND - ORANGE (REF)  
 MIDDLE BACKGROUND - WHITE (REF)

DIMENSIONS (INCHES)

A	B	C	D	E	F	G	H	J	K	M	N	P	S
36	60	5/8	3/8	4 1/2	5C	3 1/8	6E	3 1/2	15E	14 7/8	14 5/16	10 5/16	1 5/8

\* - REDUCE SPACING 50%



BID ITEM 13 - MODIFIED STANDARD DETAIL

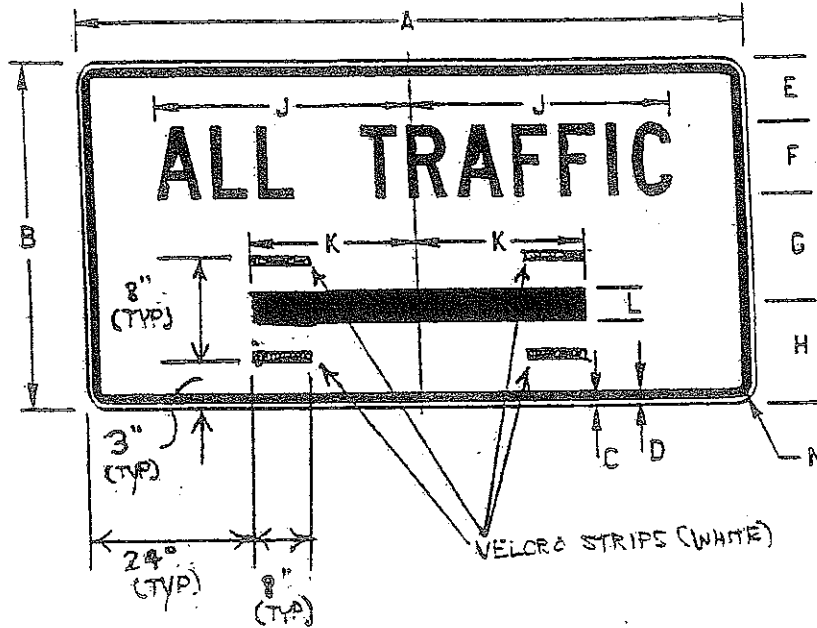

COLOR  
 LEGEND - BLACK (NON-REF)  
 BACKGROUND - WHITE (REF)

DIMENSIONS (INCHES)

A	B	C	D	E	F	G	H	J	K	L	M	N
48	24	3/8	5/8	4 1/2	5C	7 1/2	7	18 7/16	12	2 1/4		1 1/8

ARROW DETAIL

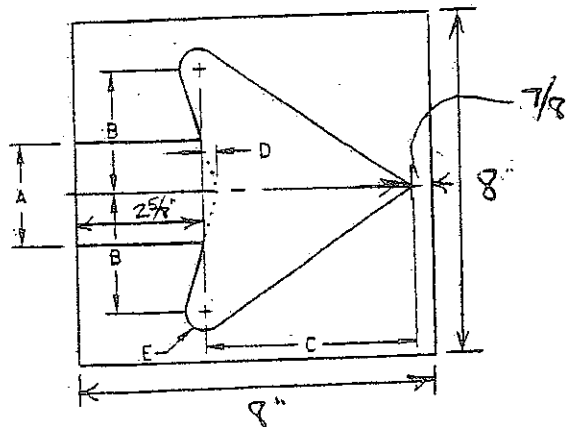

A	B	C	D	E
2 1/4	2 5/8	4 1/2	3/8	1/16

BID ITEM 17 - MODIFIED STANDARD DETAIL



COLORS  
 LEGEND - BLACK (NON-REF)  
 BACKGROUND - WHITE (REF)

DIMENSIONS (INCHES)

A	B	C	D	E	F	G	H	J	K	L
48	30	1/2	3/4	5	8D	4	13 1/4	13 1/2	19	1 3/8

BID ITEM 19 - MODIFIED STANDARD DETAIL

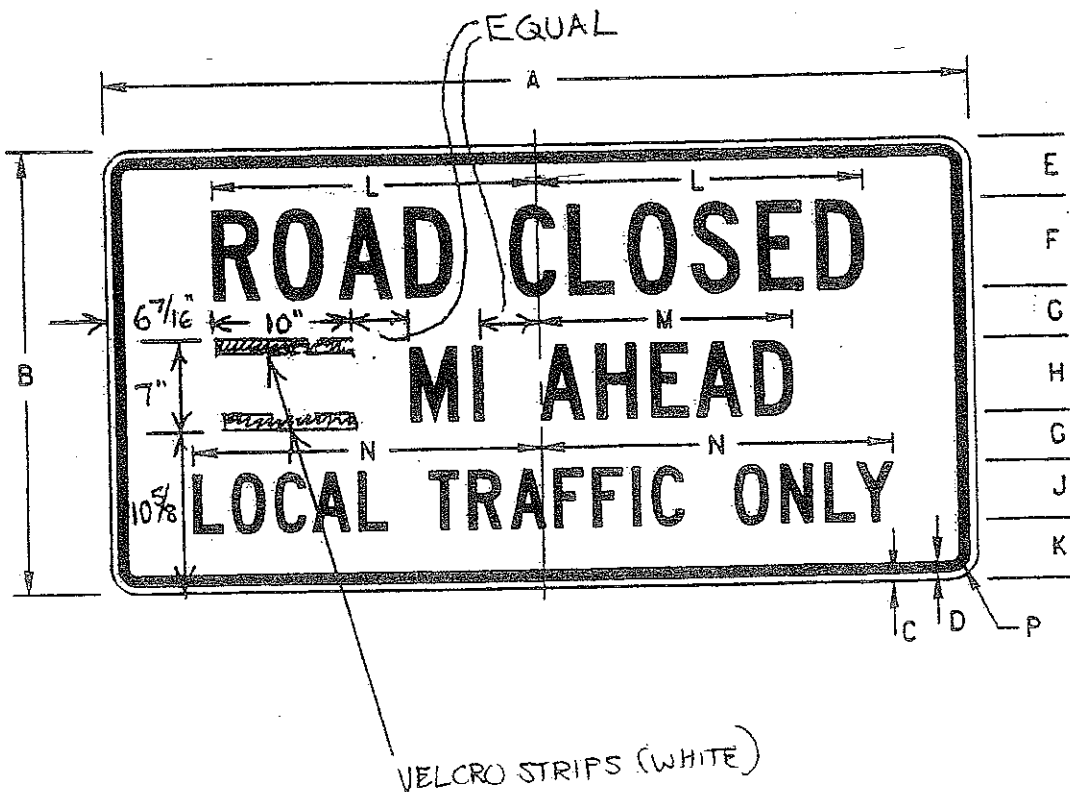

COLORS  
 LEGEND - BLACK (NON-REF)  
 BACKGROUND - WHITE (REF)

DIMENSIONS (INCHES)

A	B	C	D	E	F	G	H	J	K	L	M	N	P
60	30	1/2	3/4	4	6C	3 3/8	5C	4C	4 1/4	22 3/16	17 9/16	24 5/16	1 3/8

BID ITEM 22 - MODIFIED STANDARD DETAIL

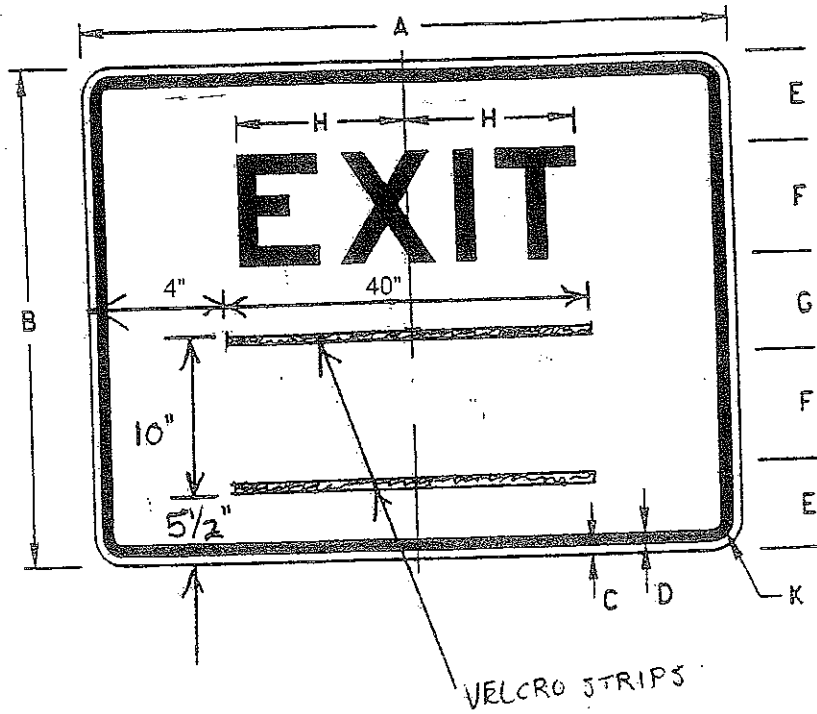

COLORS  
 LEGEND - BLACK (NON-REF)  
 BACKGROUND - ORANGE (REF)

DIMENSIONS (INCHES)

A	B	C	D	E	F	G	H		K
48	36	5/8	7/8	6 1/2	BE	7	12 3/16		1 5/8

BID ITEM 25 - MODIFIED STANDARD DETAIL

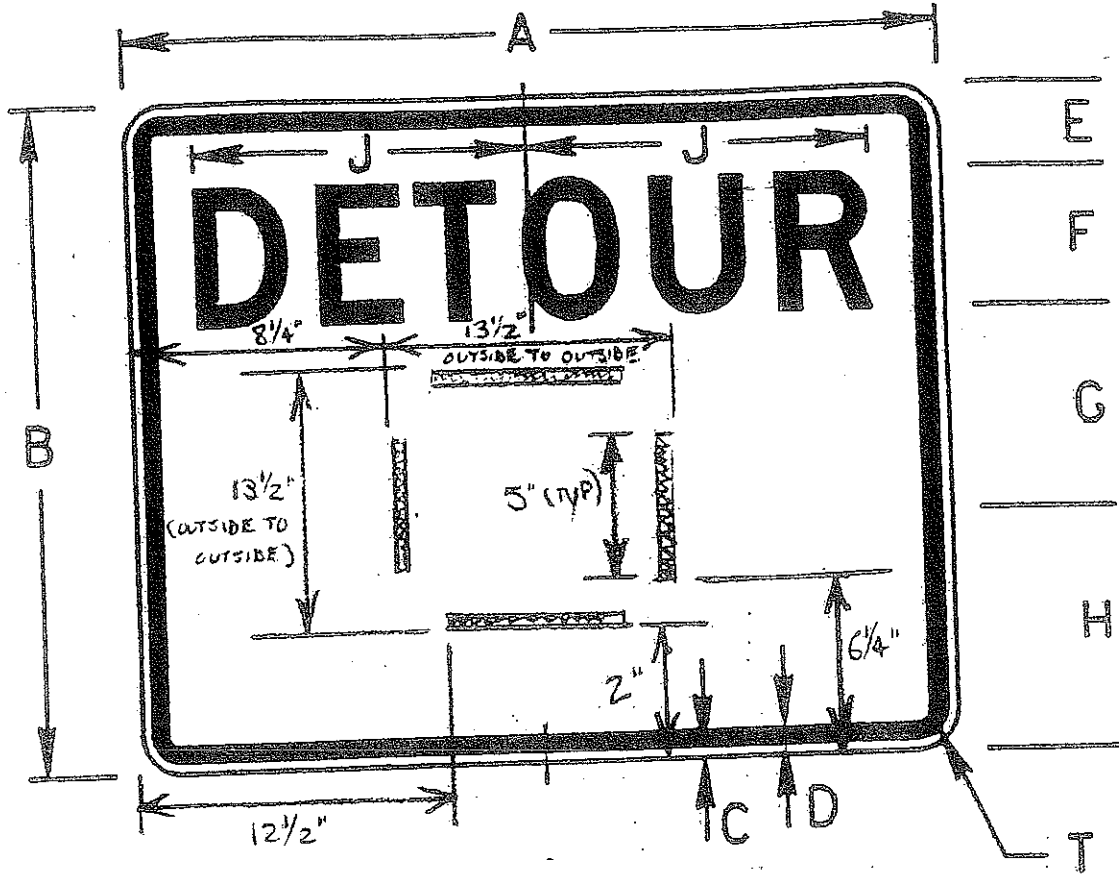

COLORS  
 LEGEND - BLACK (NON-REF)  
 BACKGROUND - ORANGE (REF)  
 DIMENSIONS (INCHES)

A	B	C	D	E	F	G	H	J	M	N	P	Q	R	S	T
30	24	3/8	5/8	3	5D	7 1/4	8 3/4	12 7/16	5	1	12 1/2	2 1/2	3	10	1 1/8

**BID ITEM 25 - MODIFIED STANDARD DETAIL (CONTINUED)**

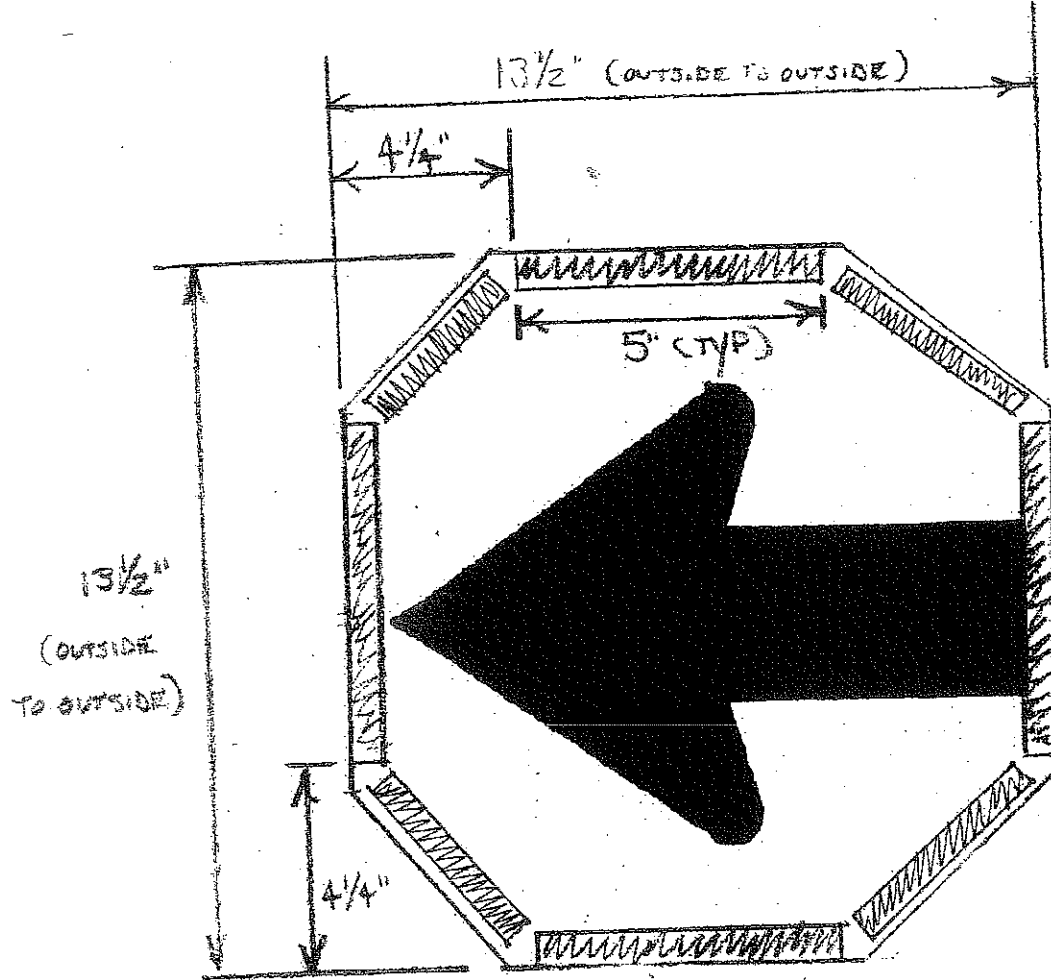

**ARROW DETAIL**

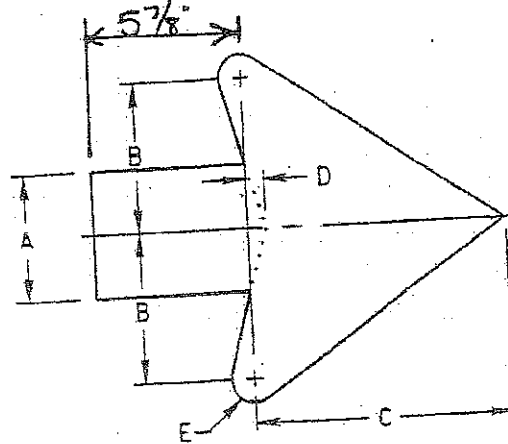

A	B	C	D	E
3 1/4	3 3/4	6 5/8	1/2	5/8

BID ITEM 26 - MODIFIED STANDARD DETAIL

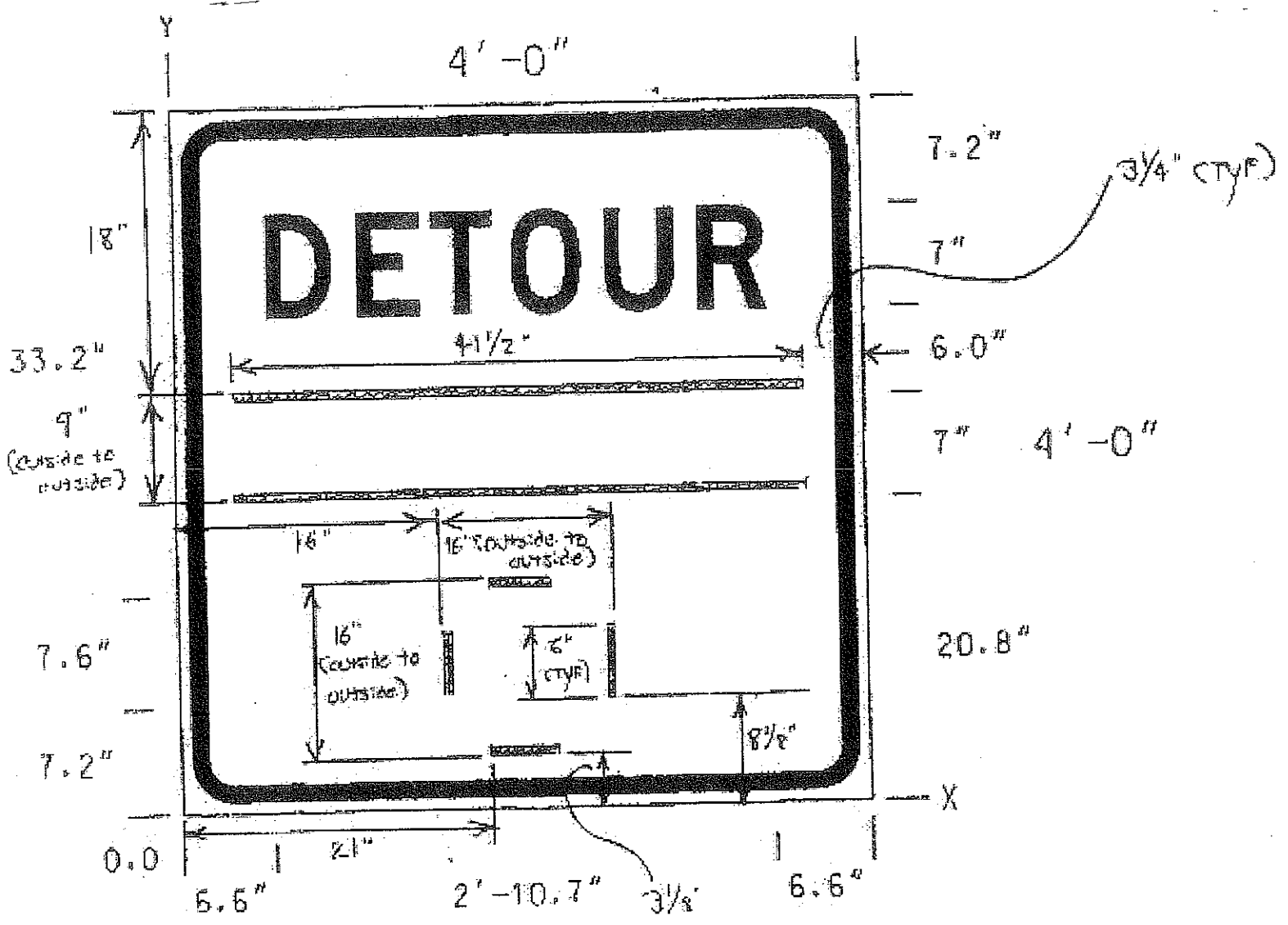

BID ITEM 26 - MODIFIED STANDARD DETAIL (CONTINUED)

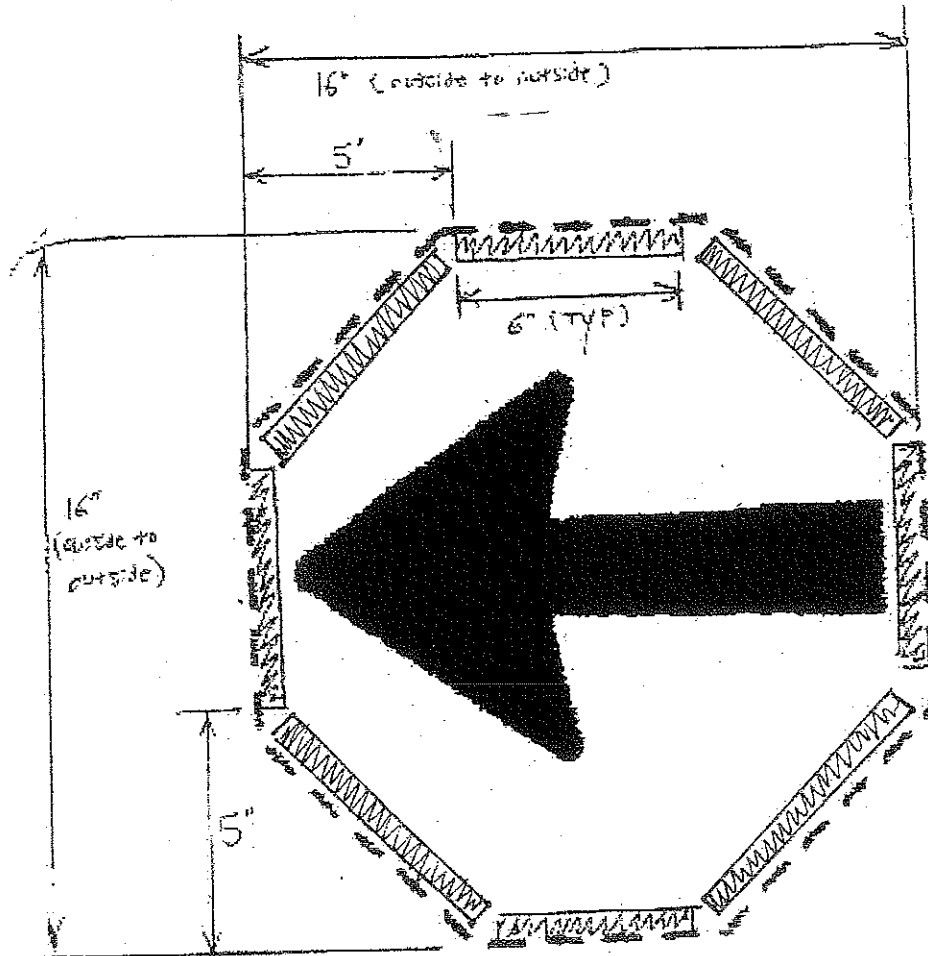

ARROW DETAIL

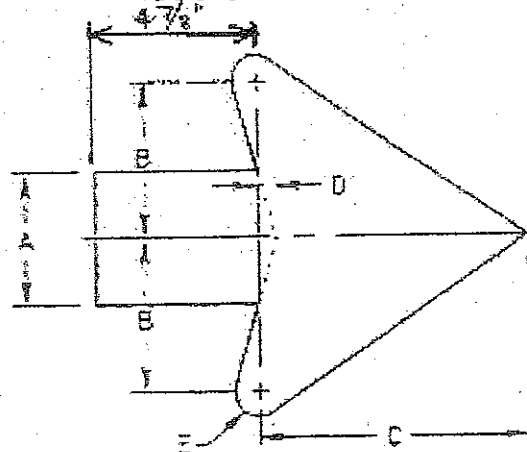

A	B	C	D	E
3 1/2	4	7 7/8	3/16	1/8



24 X 30 VERTICAL RECTANGLE -  
CORNER POCKET AND RIB CONFIGURATION

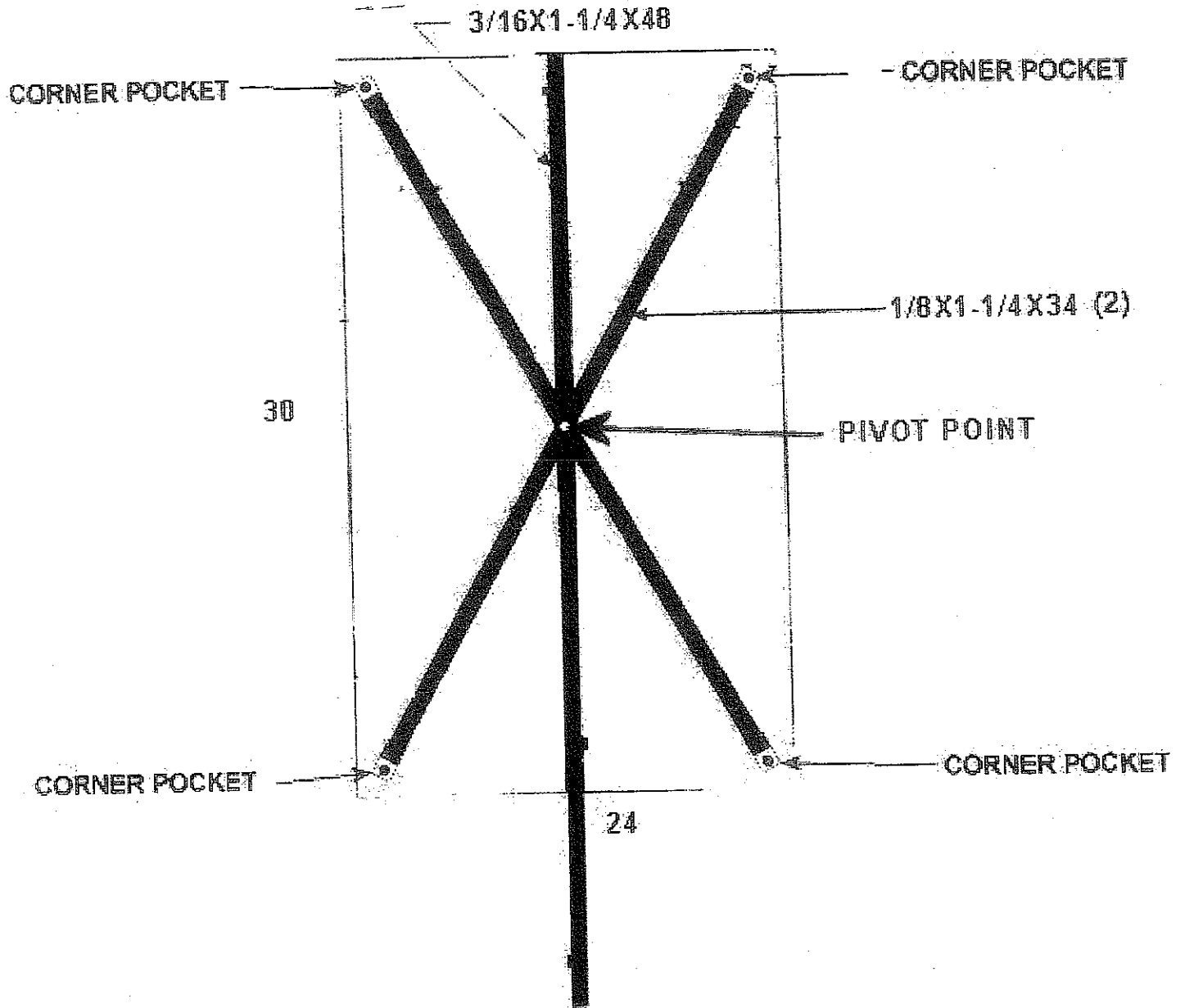

# 30X18 HORIZONTAL RECTANGLE - CORNER POCKET AND RIB CONFIGURATION

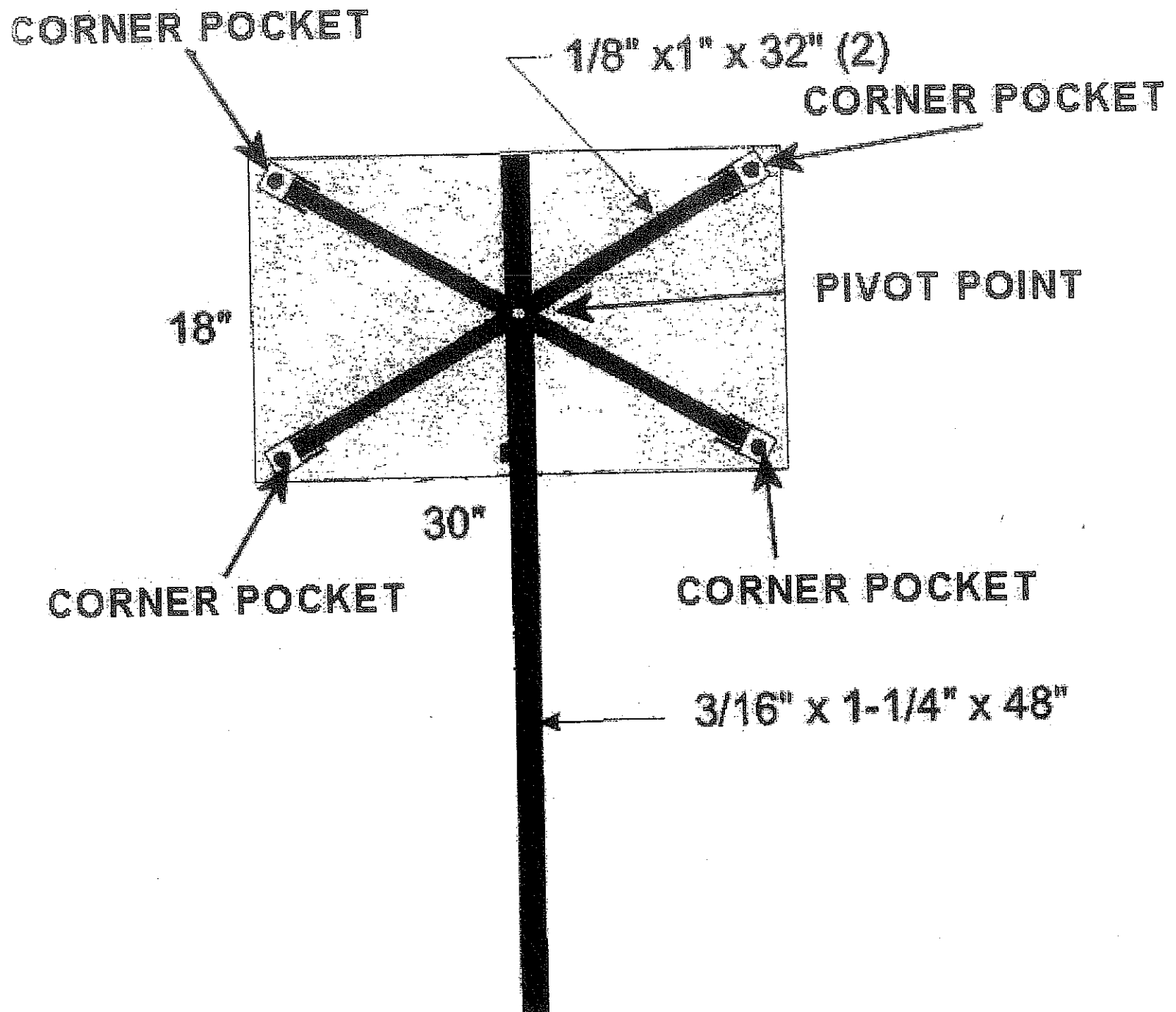

# 30X24 HORIZONTAL RECTANGLE - CORNER POCKET AND RIB CONFIGURATION

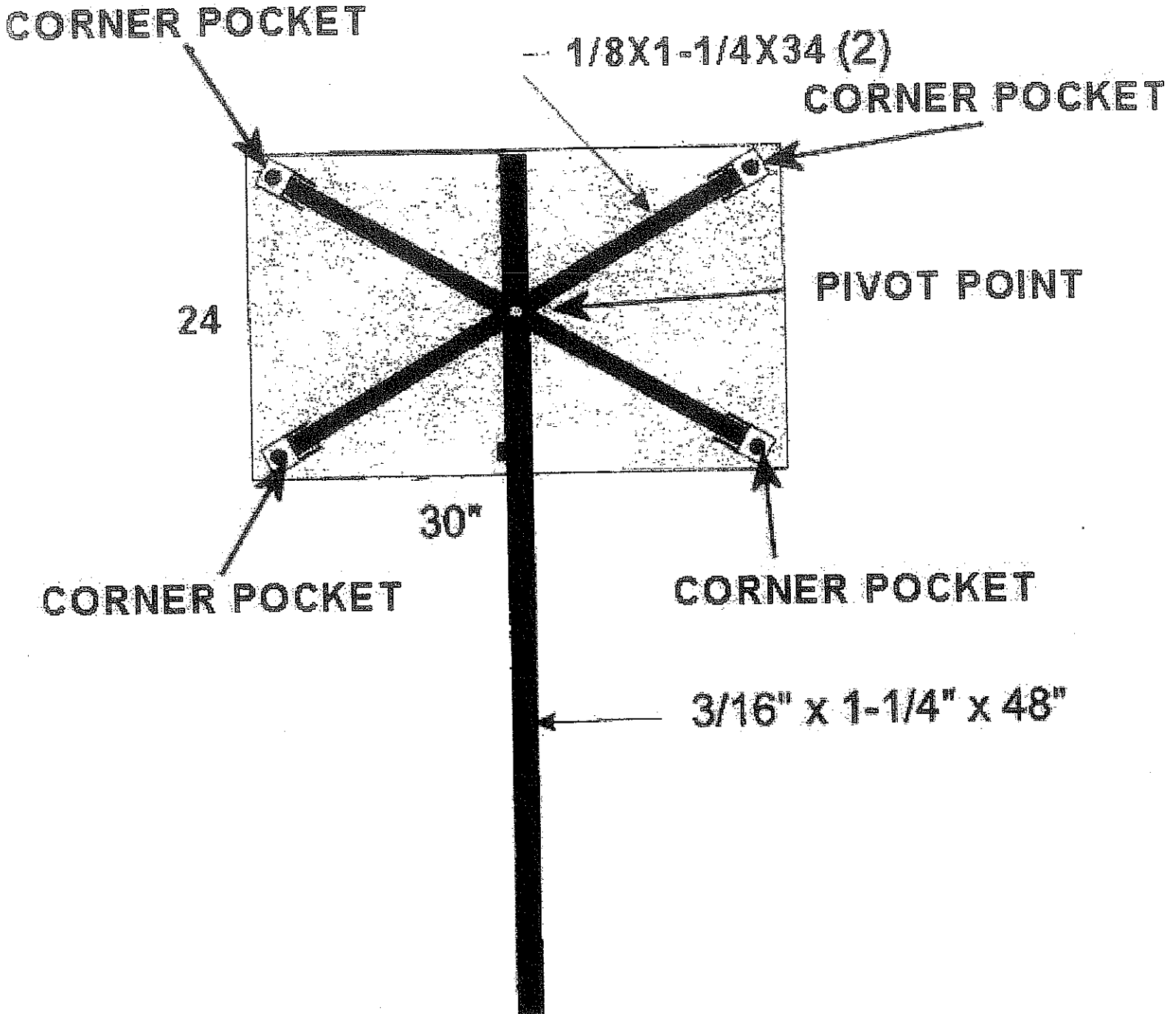

# 36" DIAMOND - CORNER POCKET AND RIB CONFIGURATION

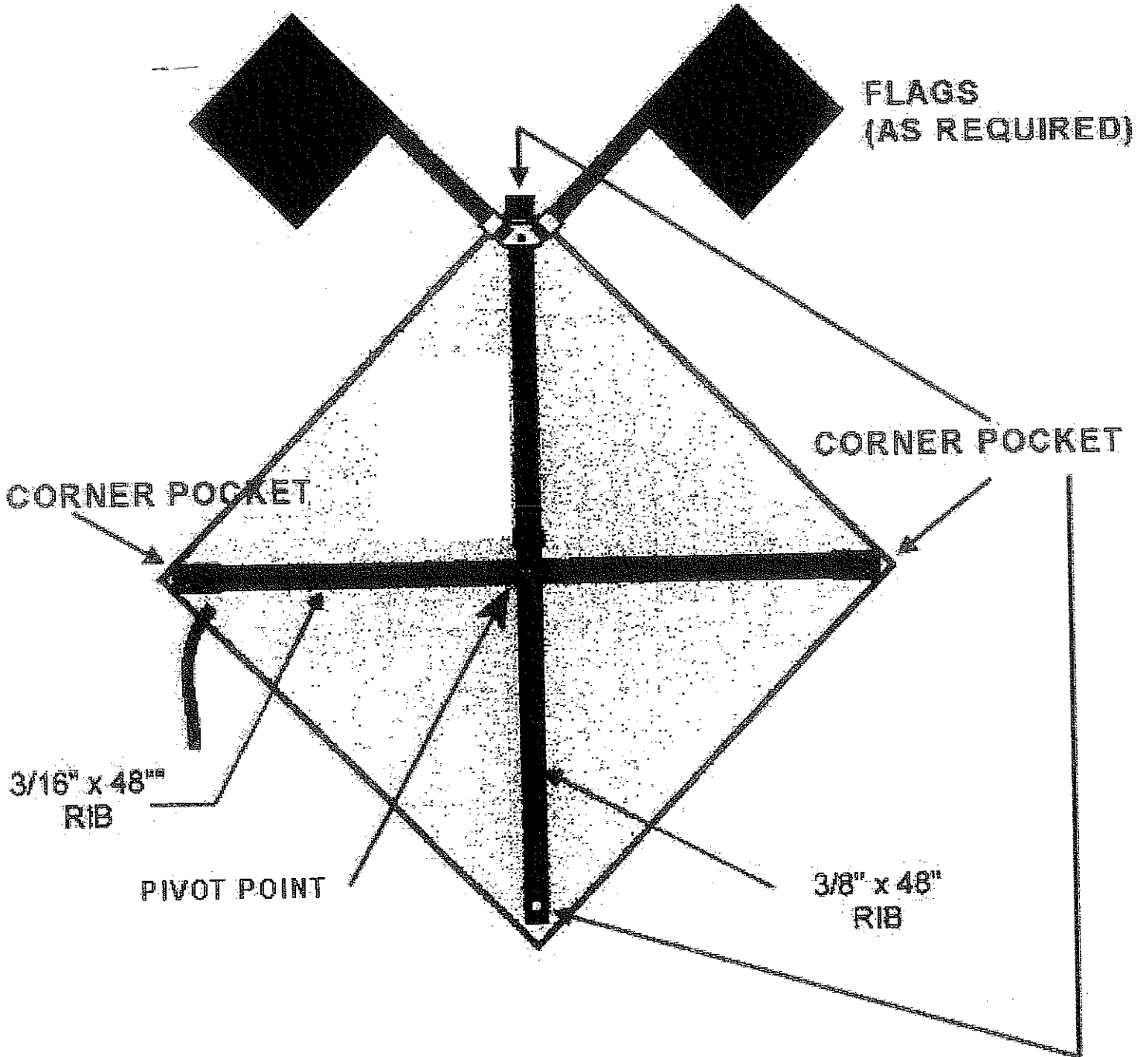

# 36" OCTAGON - CORNER POCKET AND RIB CONFIGURATION

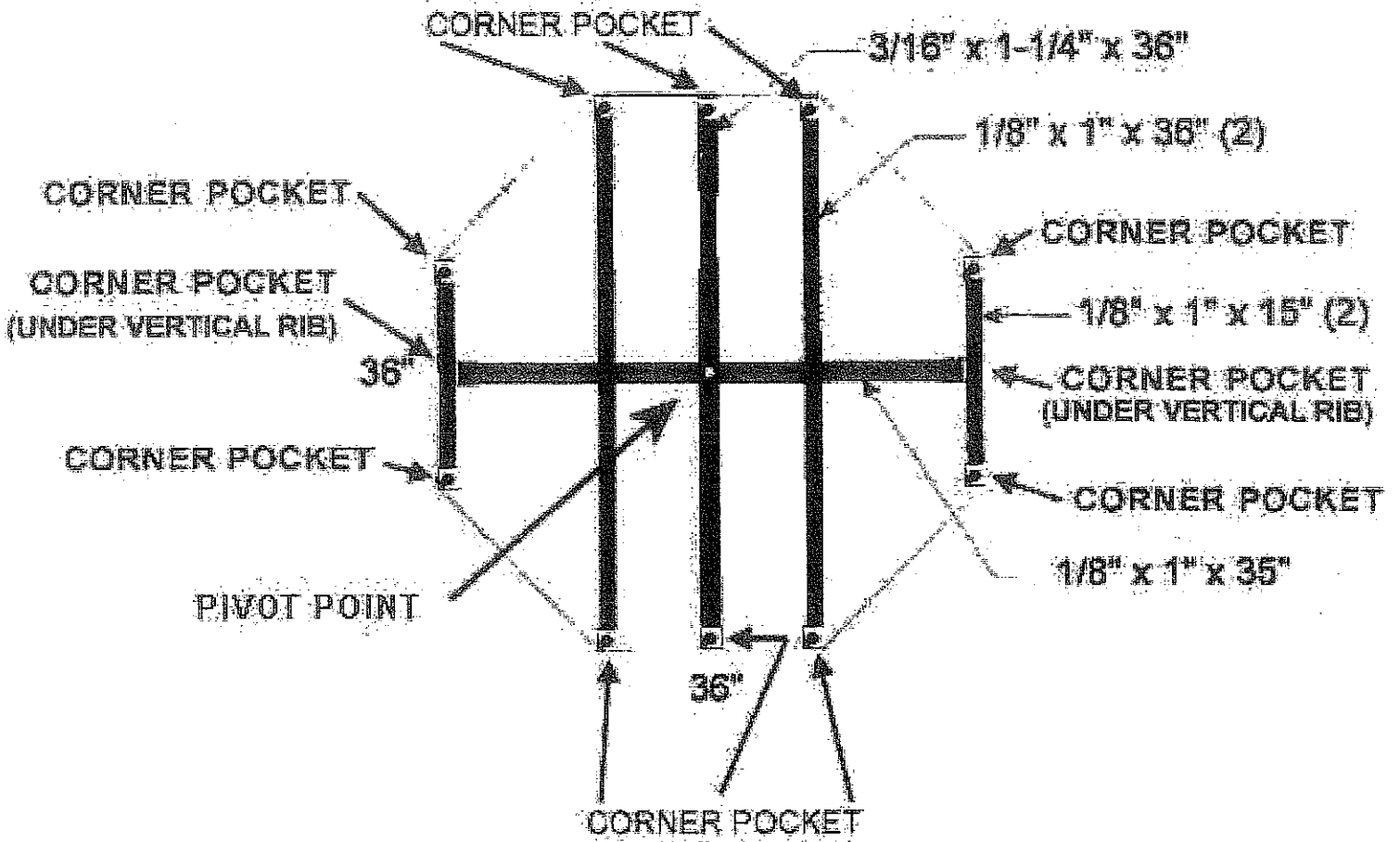

36" TRIANGLE - CORNER POCKET AND RIB CONFIGURATION

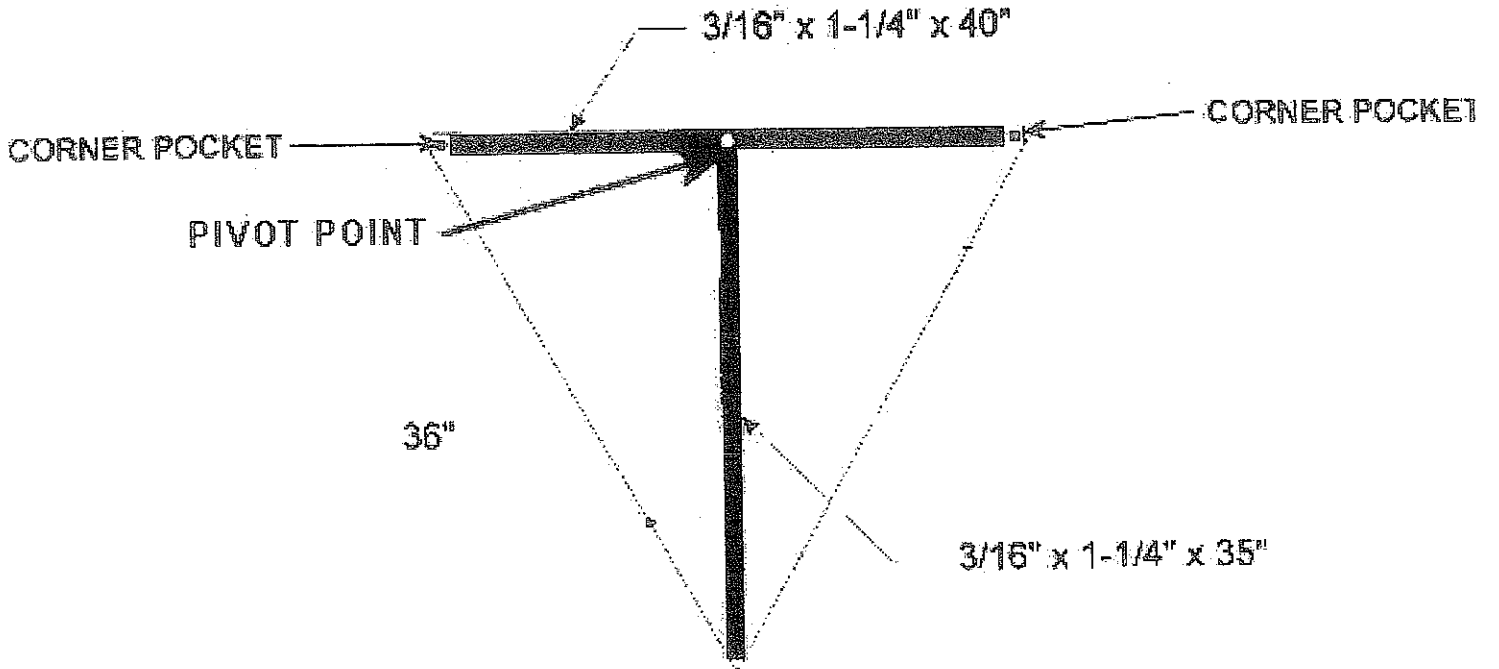

36X48 VERTICAL RECTANGLE -  
CORNER POCKET AND RIB CONFIGURATION

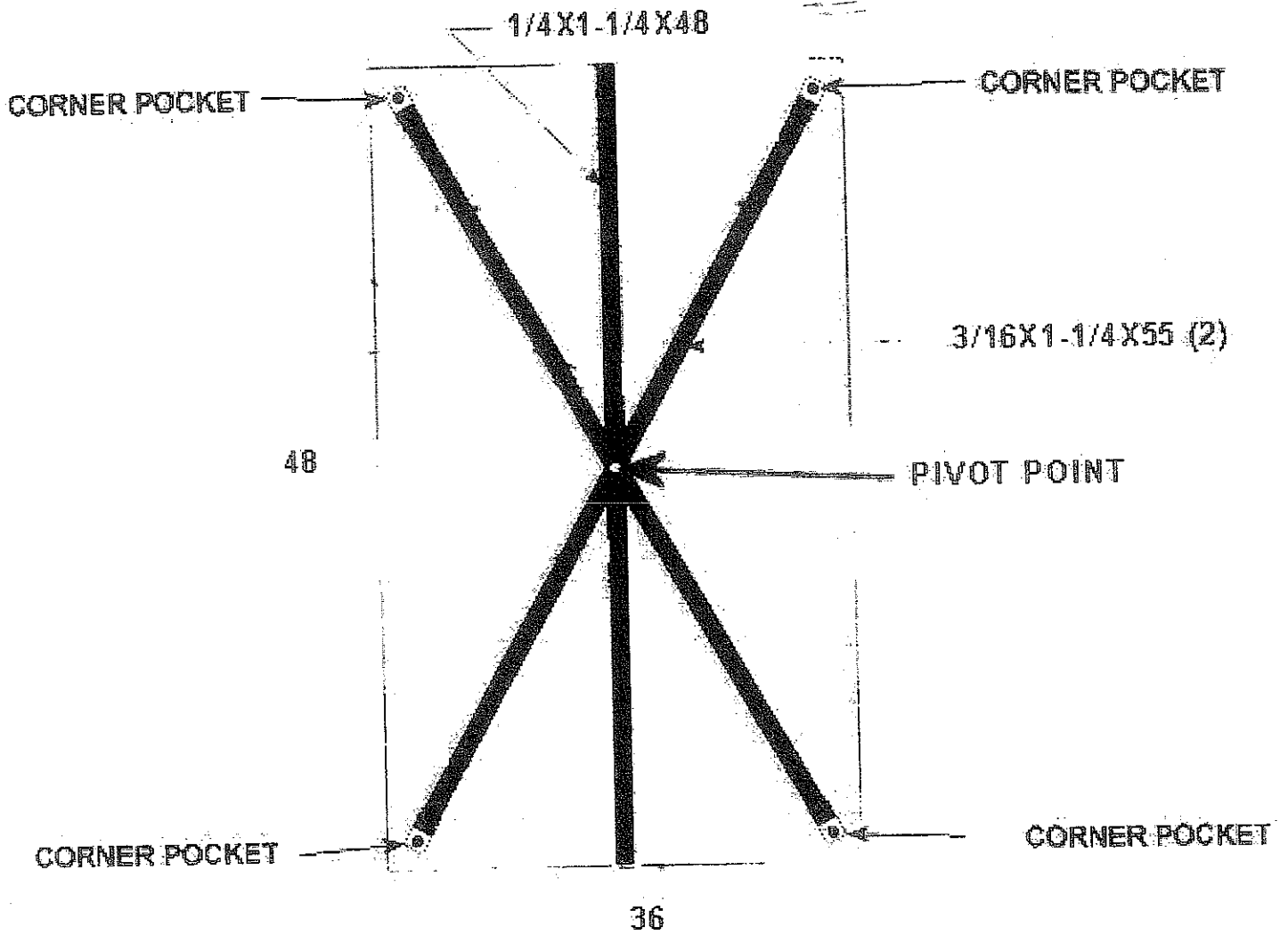

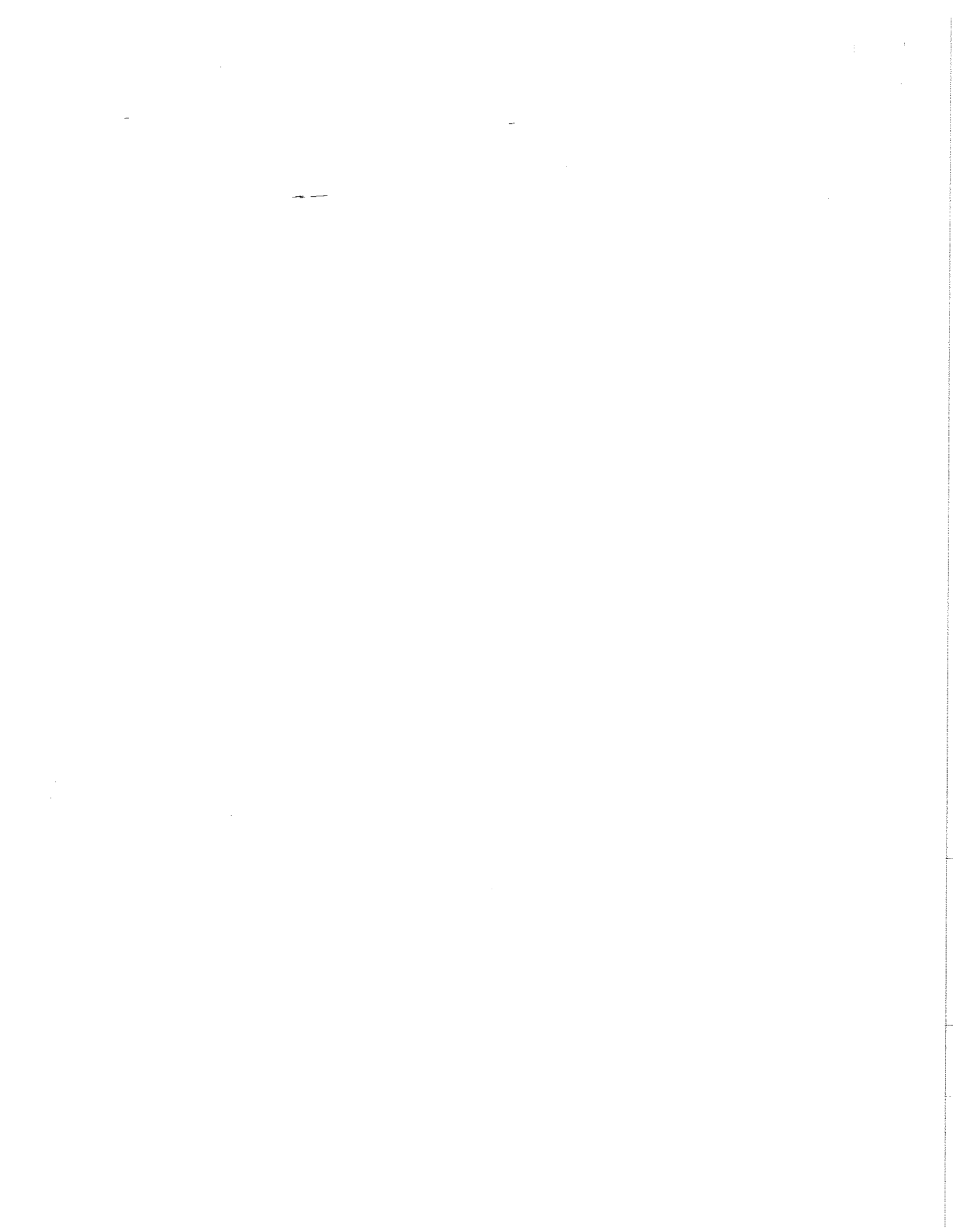



36x60 VERTICAL RECTANGLE -  
CORNER POCKET AND RIB CONFIGURATION

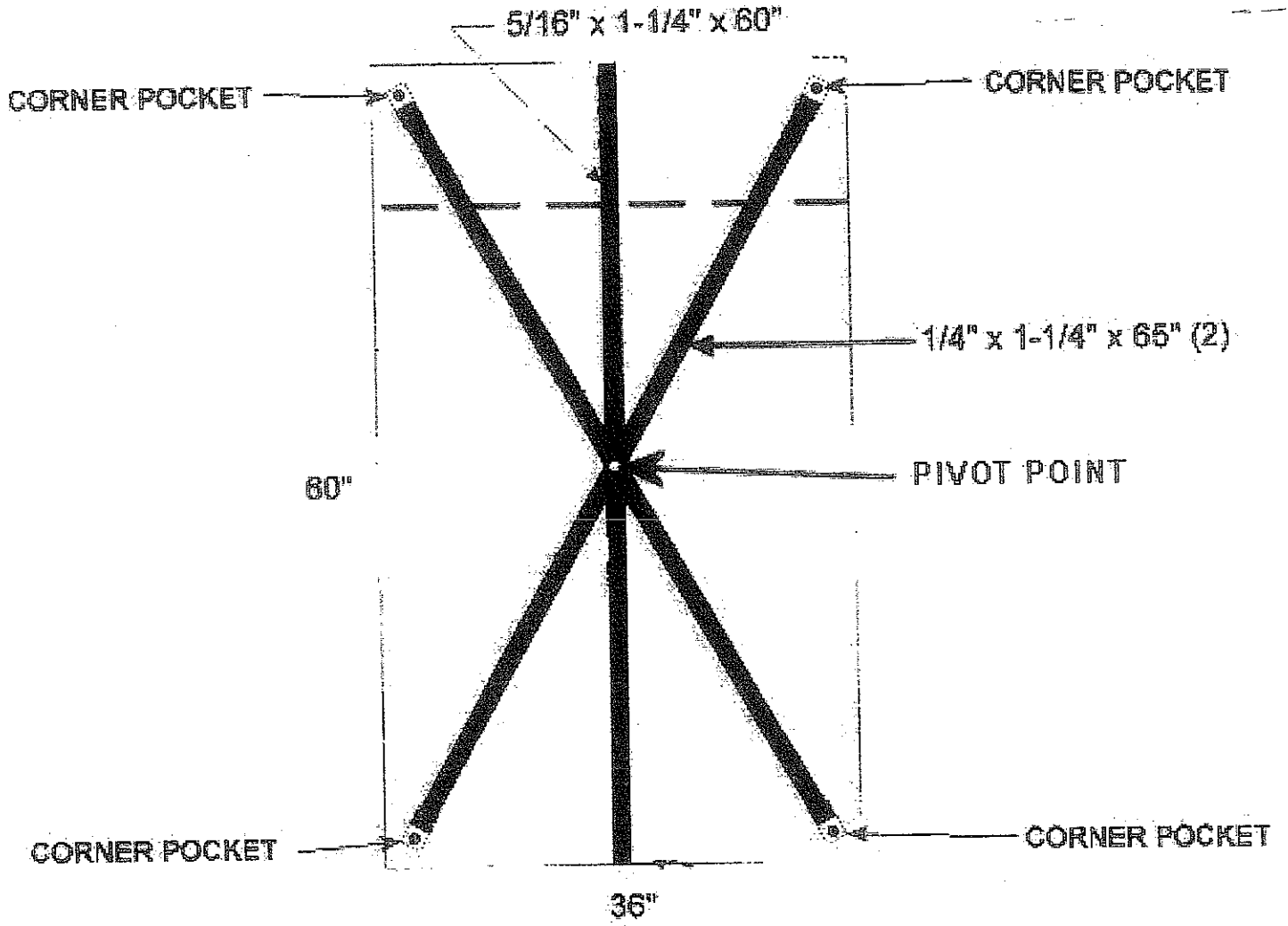

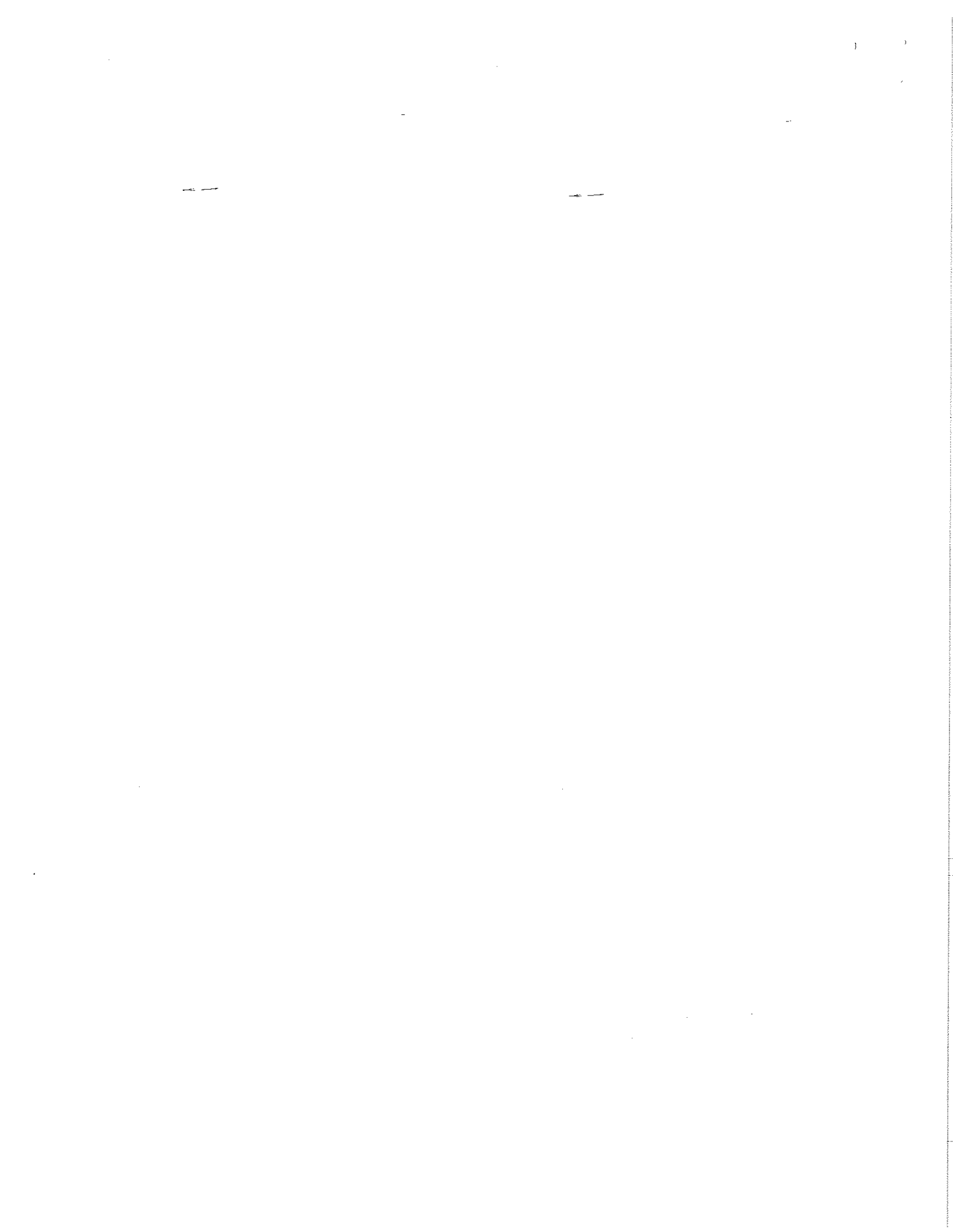

# 48x48 DIAMOND - CORNER POCKET AND RIB CONFIGURATION

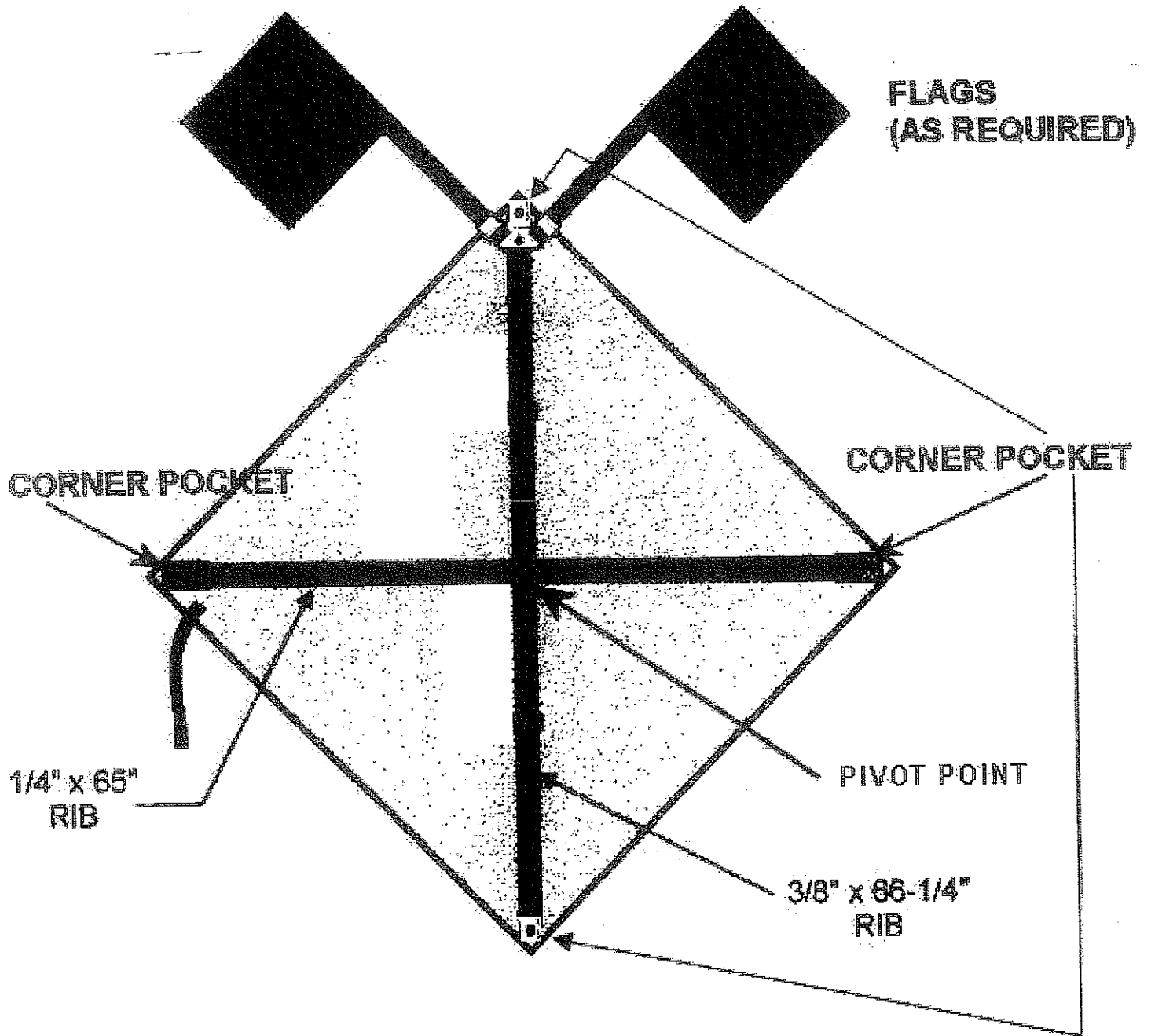

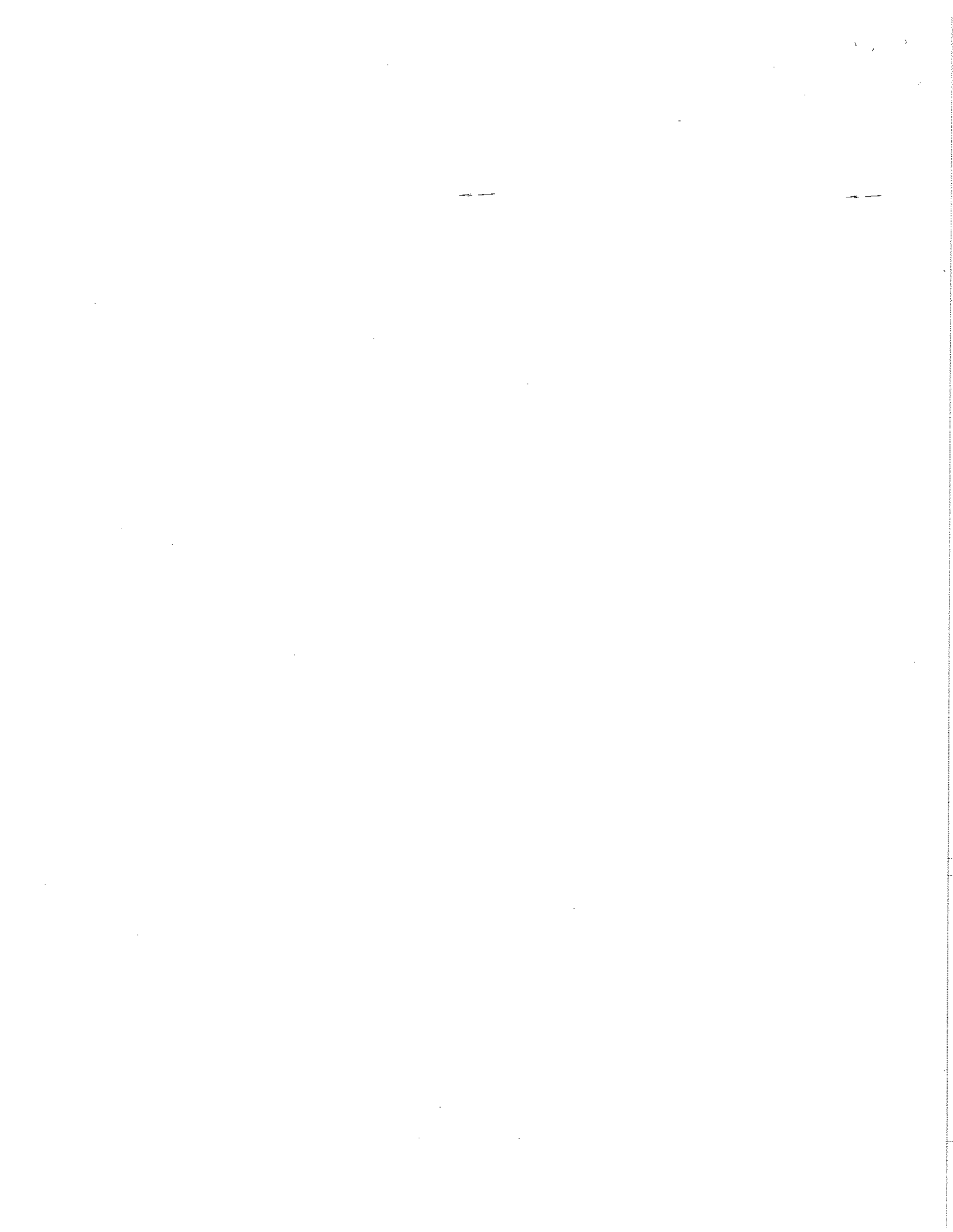

### 48" OCTAGON - CORNER POCKET AND RIB CONFIGURATION

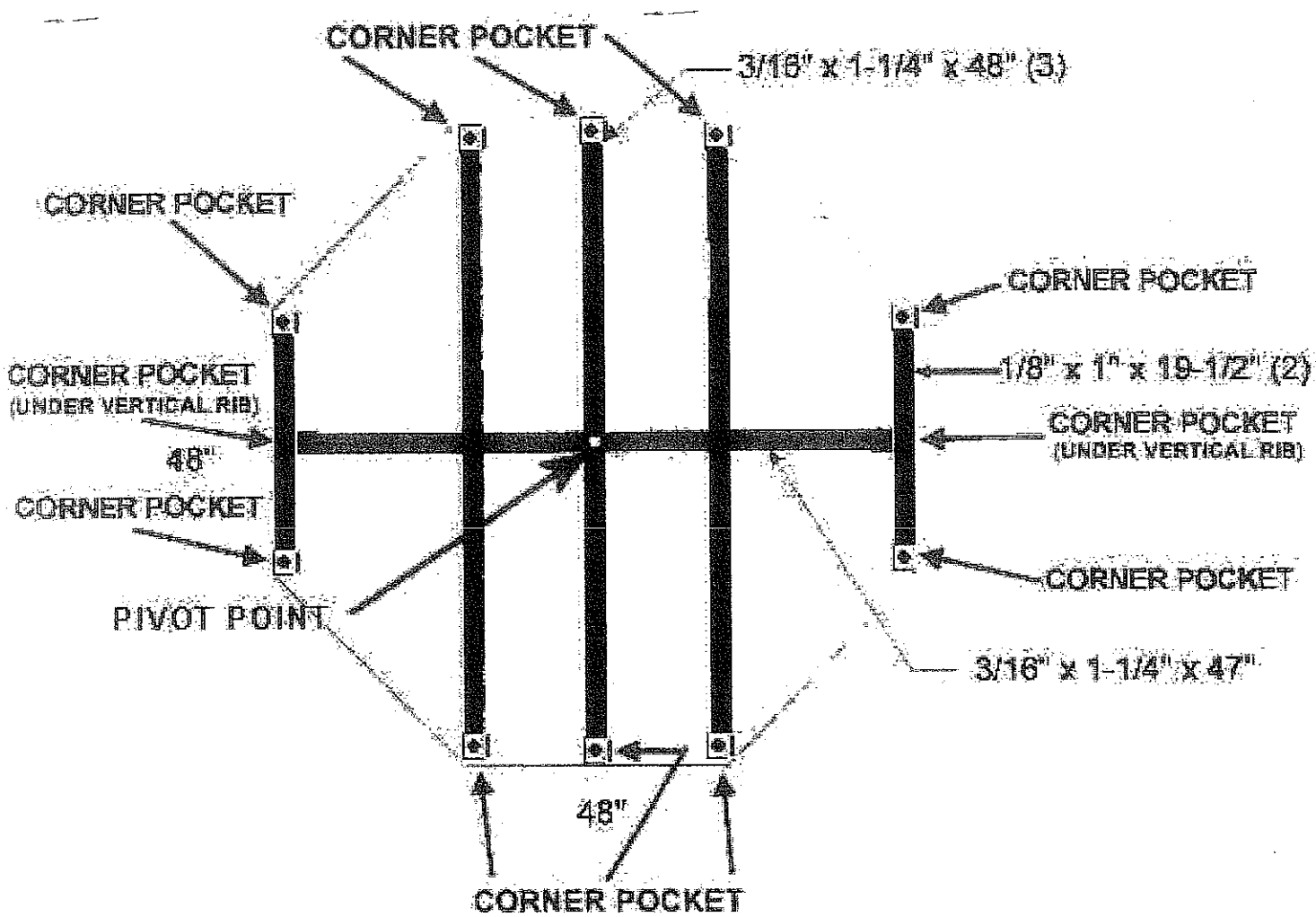

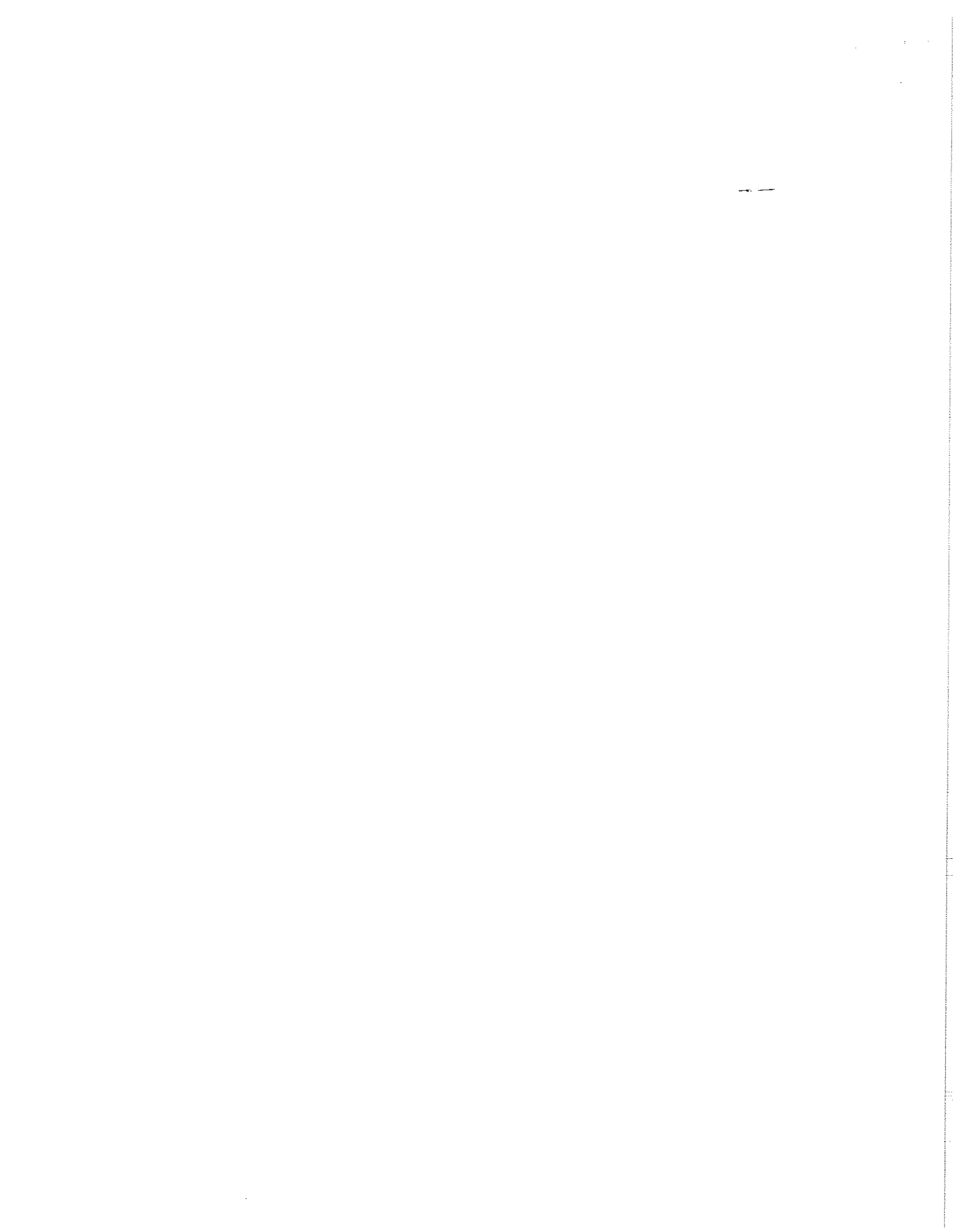

# 48x48 SQUARE - CORNER POCKET AND RIB CONFIGURATION

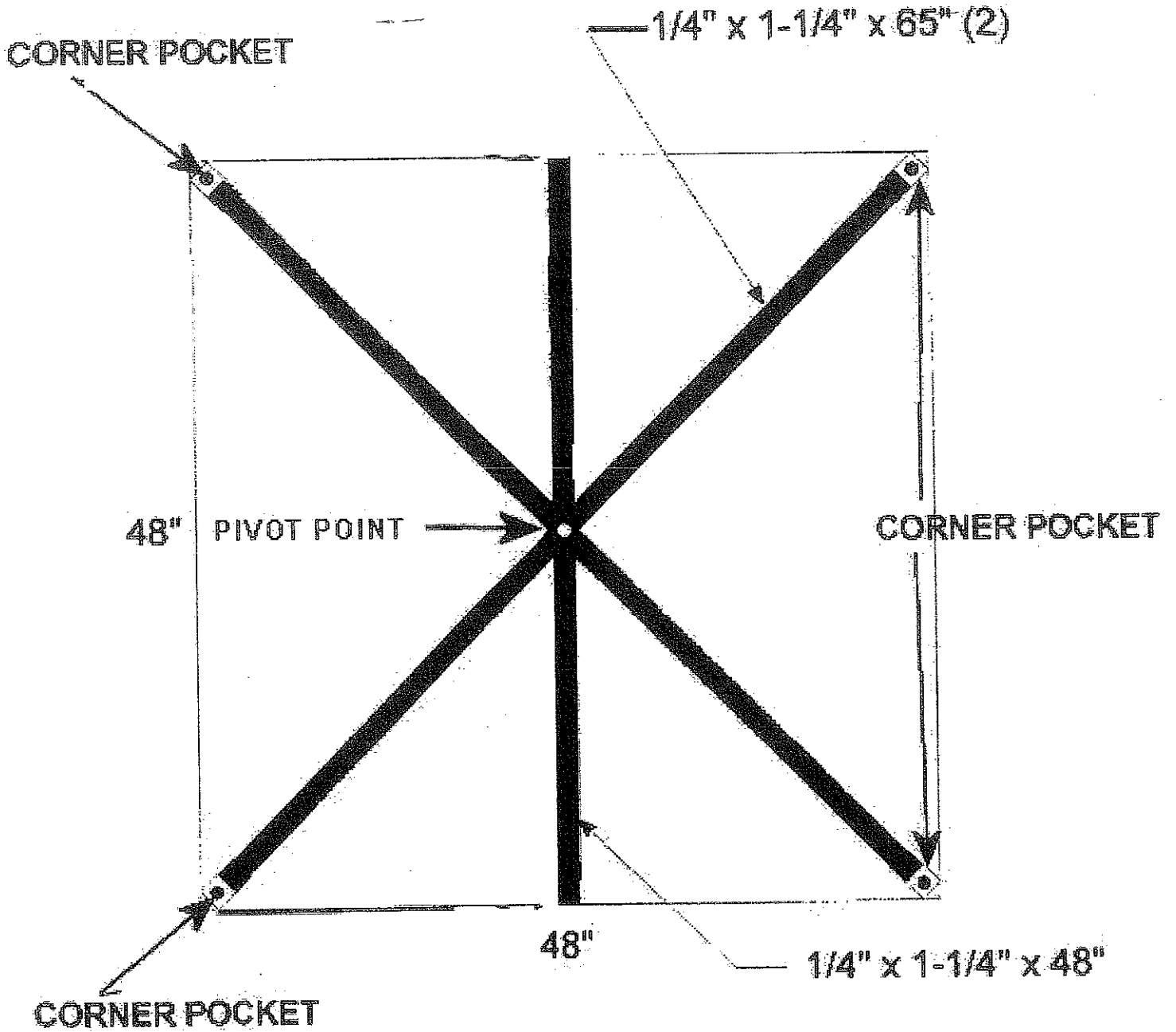

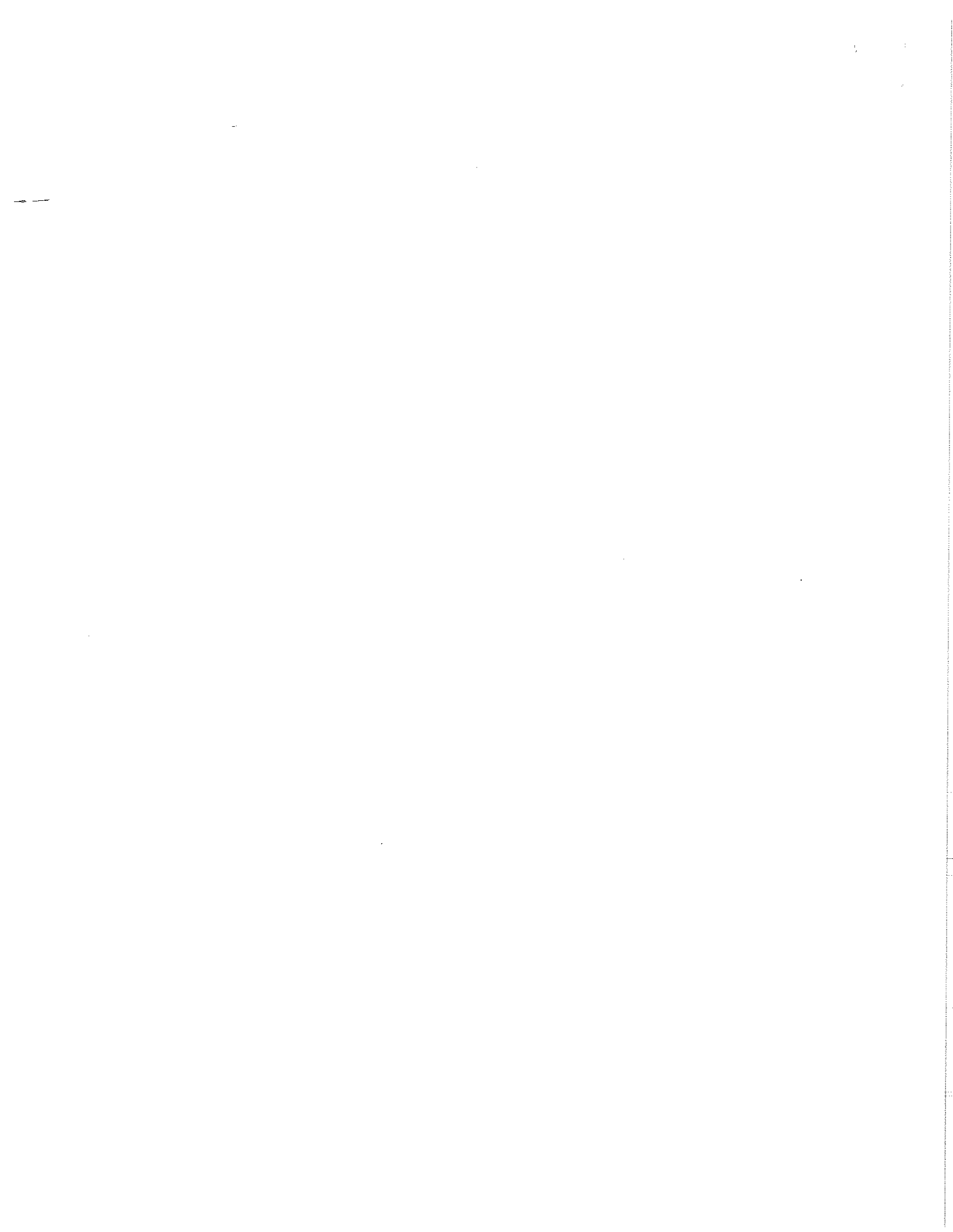



# 48" TRIANGLE - CORNER POCKET AND RIB CONFIGURATION

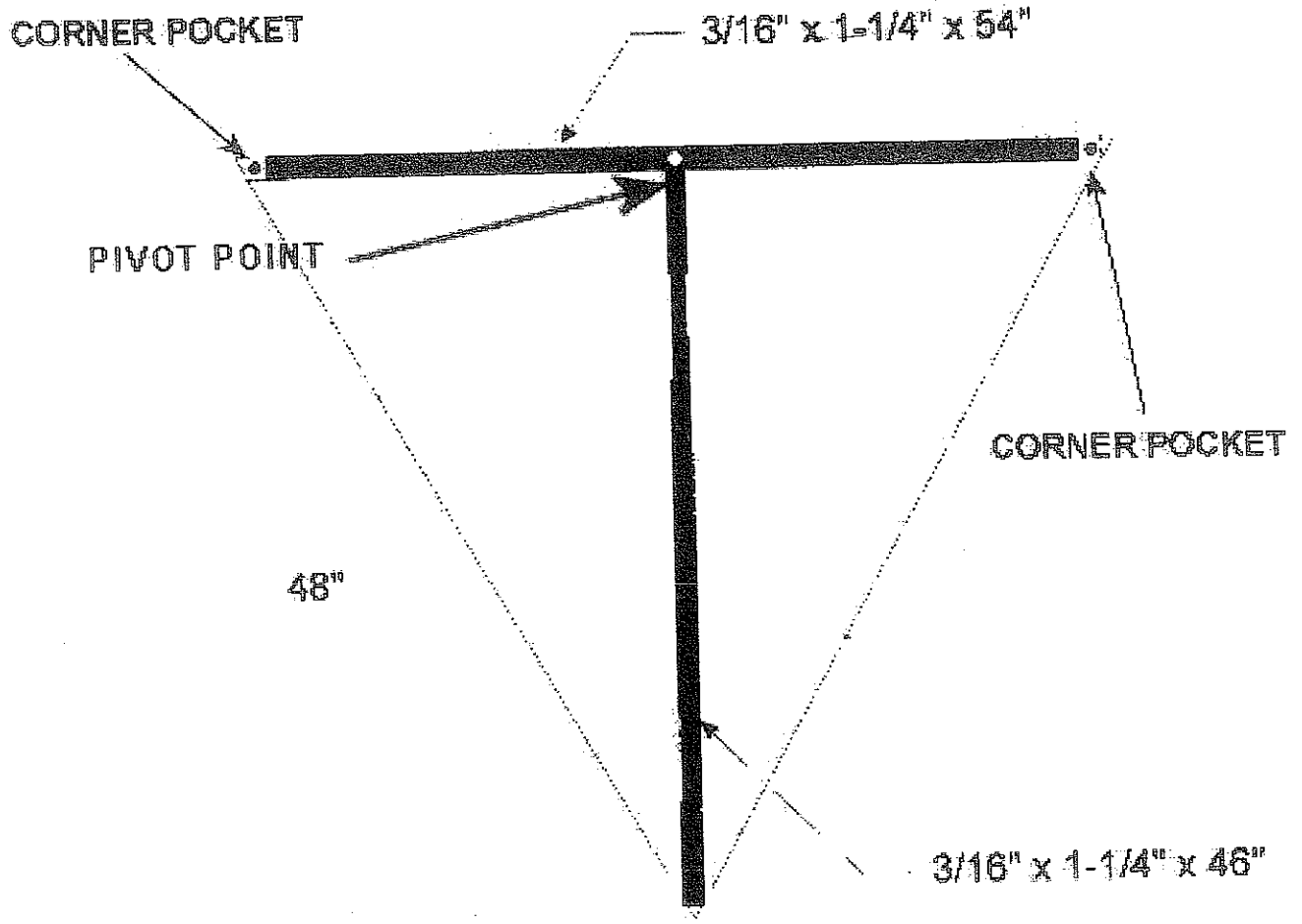

# 48X24 HORIZONTAL RECTANGLE - CORNER POCKET AND RIB CONFIGURATION

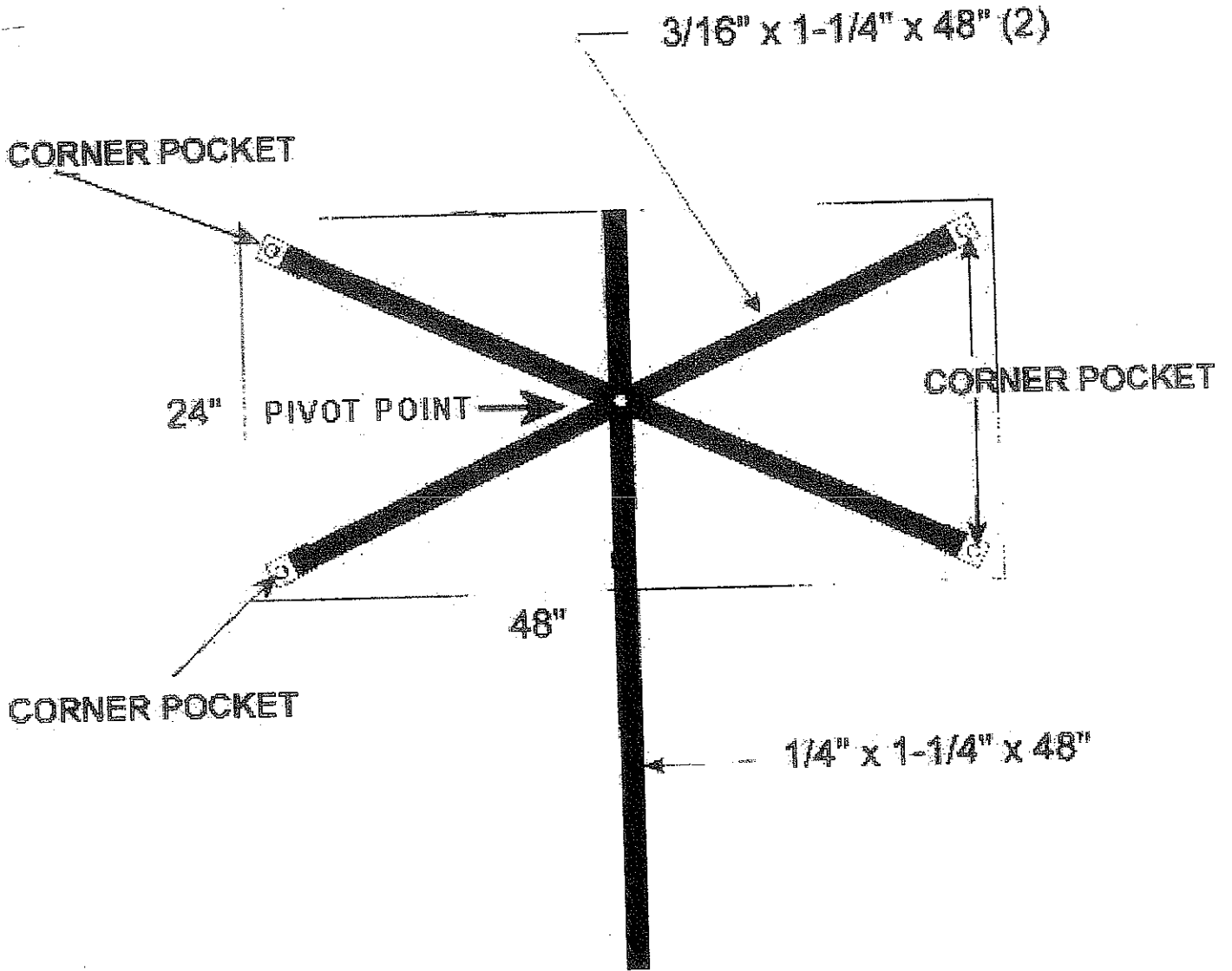

**48x30 HORIZONTAL RECTANGLE -  
CORNER POCKET AND RIB CONFIGURATION**

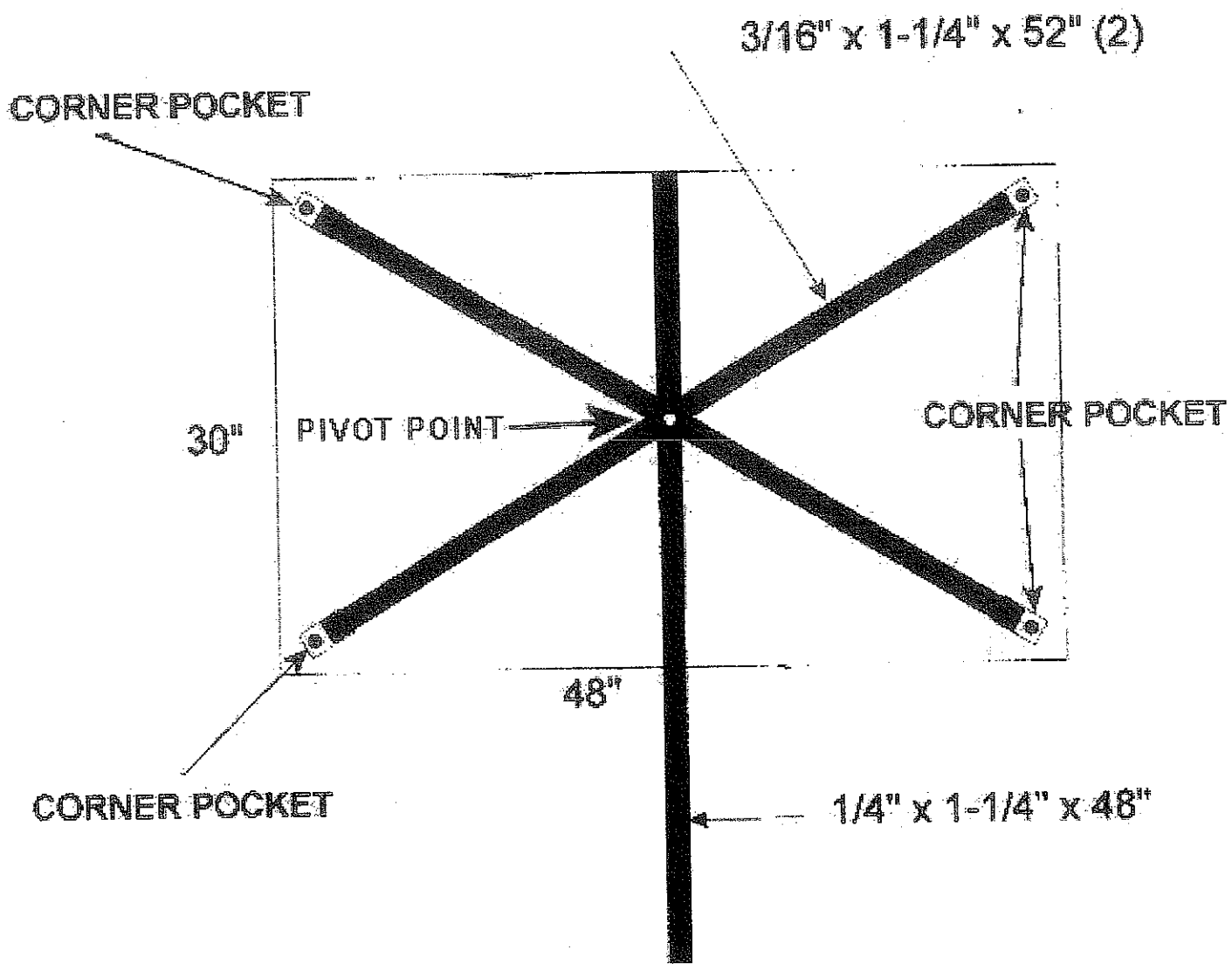

# 48x36 HORIZONTAL RECTANGLE - CORNER POCKET AND RIB CONFIGURATION

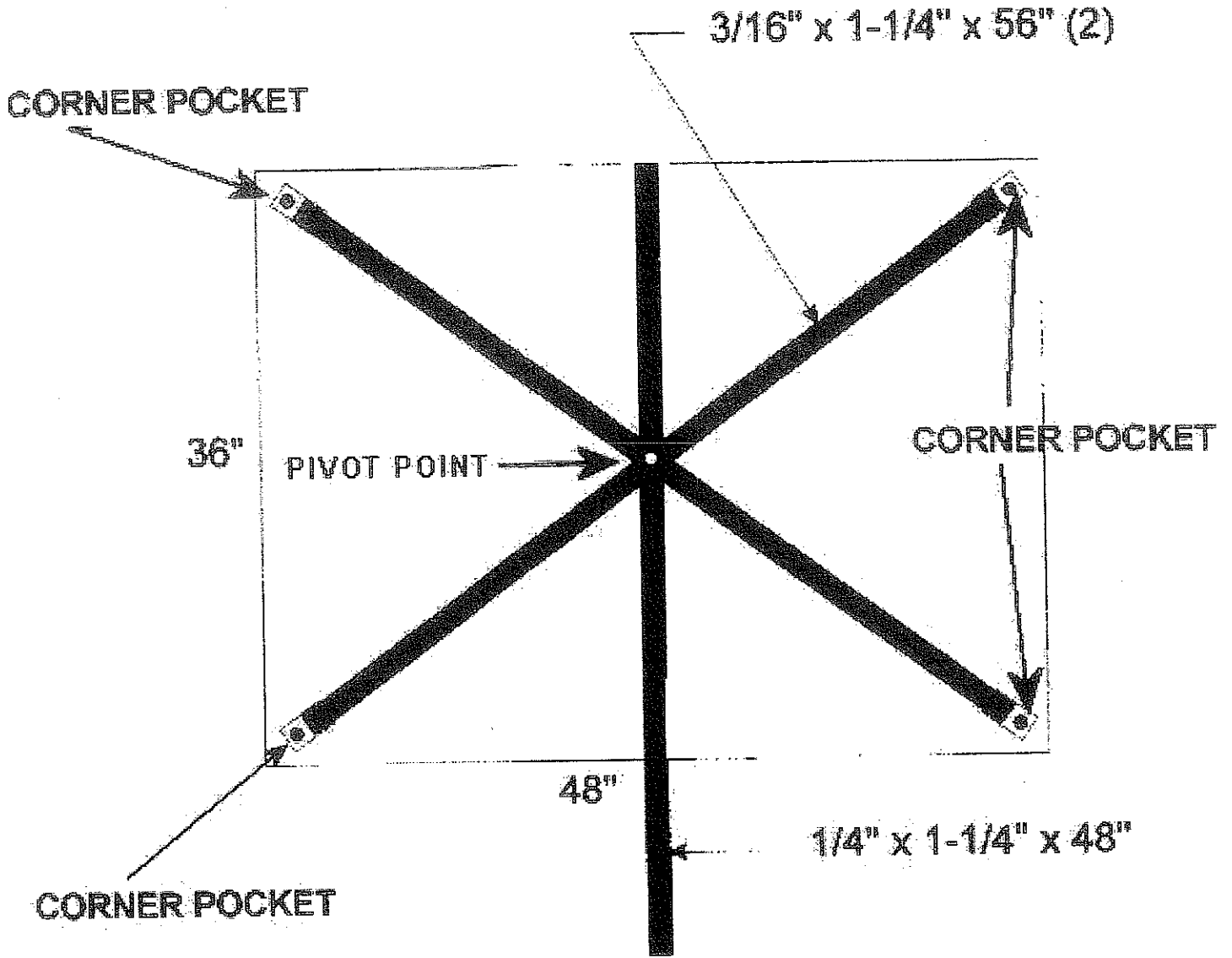

### 60X60 SQUARE - CORNER POCKET AND RIB CONFIGURATION

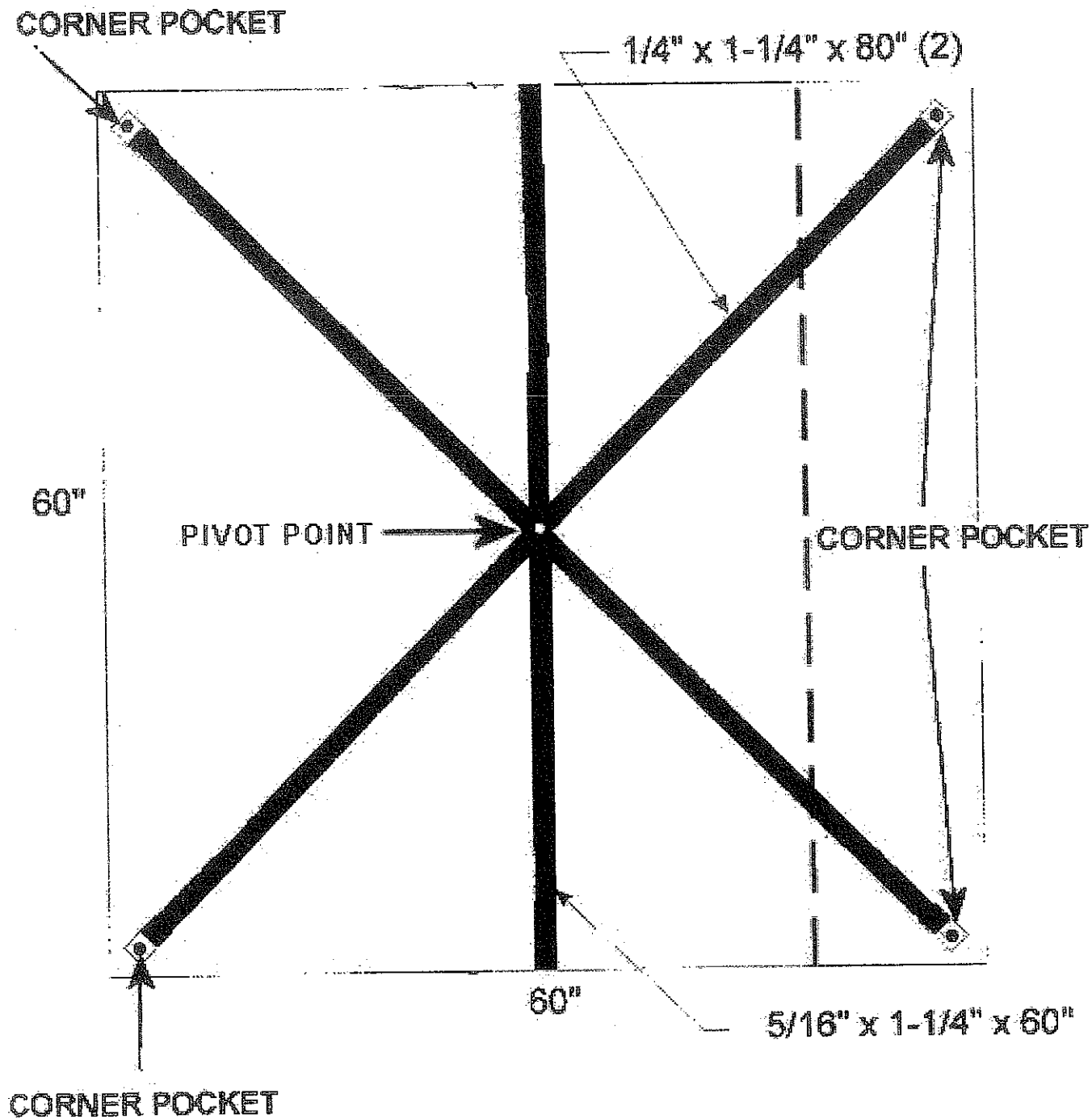

60X30 HORIZONTAL RECTANGLE -  
CORNER POCKET AND RIB CONFIGURATION

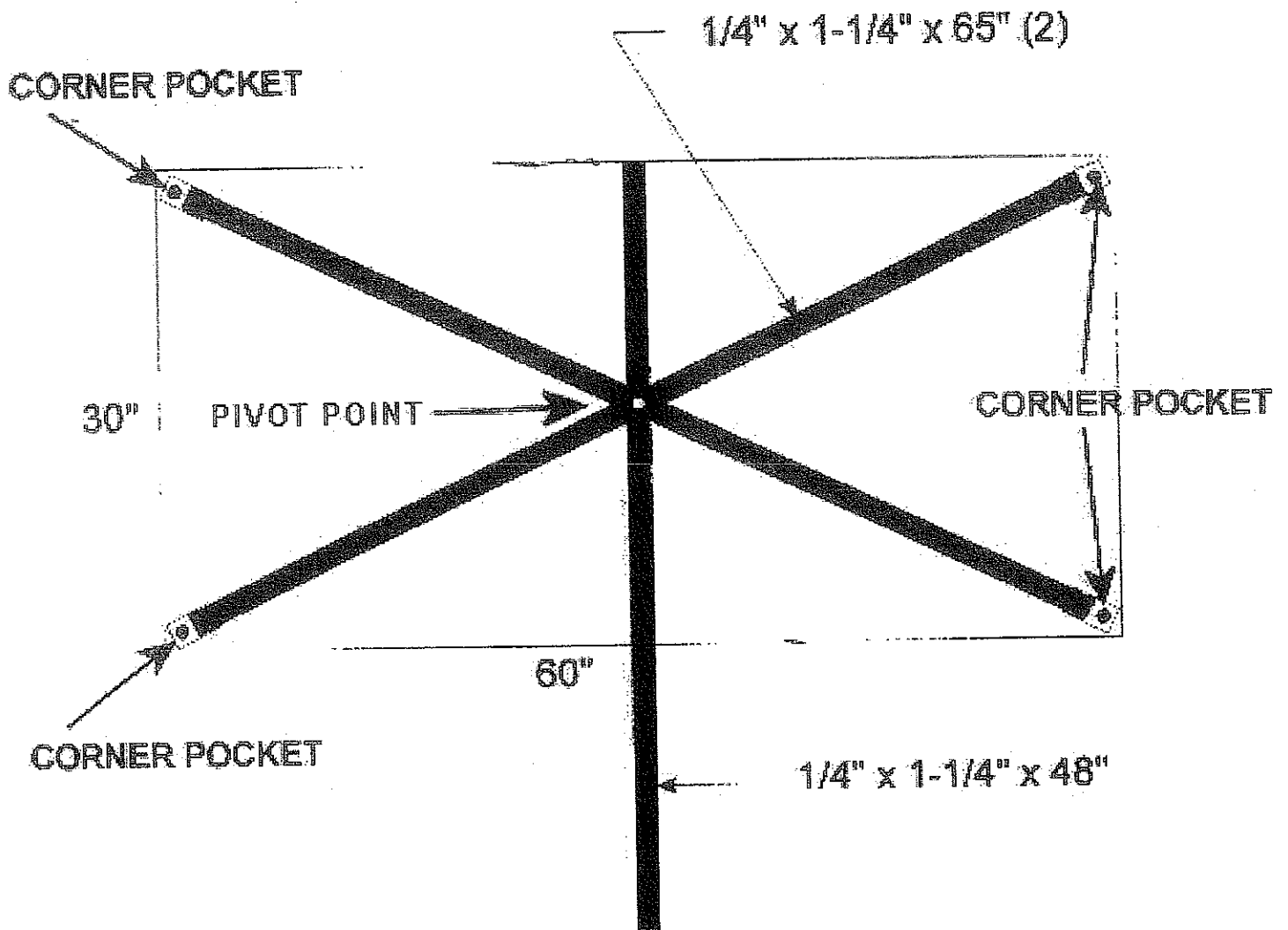

**SCHEDULE**  
 following estimated quantities are for bid purposes only. Actual quantities will be determined by needs of the West Virginia Division of Highways and may be increased or decreased:

ITEM NUMBER	ESTIMATED QUANTITY	DESCRIPTION	INVENTORY SUBCODE (DOH USE)	UNIT PRICE	TOTAL AMOUNT
<b>STAND PORTION</b>					
1	600	EA., COMPACT PORTABLE SIGN STAND	080508	74.55	44730.00
2	50	EA., LARGE, ALUMINUM SUBSTRATE SIGN AND OVERSIZED ROLL-UP SIGN PORTABLE SIGN STAND	080509	100.34	5017.00
<b>SIGN PORTION</b>					
3		EA, 36" R1-1F "STOP" sign	010107	78.19	
4	5	EA, 48" R1-1F "STOP" sign	010108	106.63	533.15
5		EA, 36" W3-1MF SYMBOLIC "STOP AHEAD" sign		82.02	
6	5	EA, 48" W3-1MF SYMBOLIC "STOP AHEAD" sign	020309	116.10	580.50
7		EA, 36" R1-2F "YIELD" sign		56.15	
8	30	EA, 48" R1-2F "YIELD" sign	010114	85.37	2561.10
9		EA, 36" W3-2MF SYMBOLIC "YIELD AHEAD" sign		95.51	
10	5	EA, 48" W3-2MF SYMBOLIC "YIELD AHEAD" sign		136.90	684.50
11	10	EA., 36" x 60" R2-1MF "WORK ZONE SPEED LIMIT _____" W/ HOOK & LOOP FOR NUMERAL OVERLAY PLAQUES (ORDER NUMERALS UNDER ITEM #12)	010289	111.00	1110.00

**ORDERING NOTES FOR DOH PERSONNEL:**  
 1. ROAD SIGNS WITH TEXT TO BEGINNING "ROAD WORK" ARE TO BE ORDERED UNDER ITEM NUMBERS 30, 32, 34, OR 36 ONLY. W20-7A AND W21-1A SIGNS ARE TO BE ORDERED UNDER ITEM NUMBERS 30 OR 32 ONLY.  
 2. #24 IS TO BE INSTALLED ONLY ON THE STAND PROVIDED UNDER ITEM #2.  
 3. ATTACHED COMMISSIONER'S ORDERS REGARDING THE PROPER USE OF ITEM # 11. BASED ON THESE COMMISSIONER'S ORDERS, THIS ITEM MAY BE USED ONLY ON CONTROLLED ACCESS FREEWAYS OR EXPRESSWAYS IN THE DURATION OF THE OF THE WORK ACTIVITY IS NOT TO EXCEED ONE DAYLIGHT PERIOD.  
 4. STAND SUPPLIED AS PART OF BID ITEM #2 IS NOT TO BE USED WITH ALUM SUBSTRATE SIGNS LARGER THAN 48X48 (DIAMOND), 60X30 (HORIZONTAL RECTANGLE), 36X60 (VERTICAL RECTANGLE), 48" (OCTAGON), (SQUARE), OR 48" (TRIANGLE). CONTACT DT FOR SPECIAL NEEDS.  
 5. DIAMOND SHAPED SIGNS WHICH MAY POTENTIALLY BE ALTERED WITH OVERLAY PLAQUES ARE TO BE ORDERED WITH HOOK AND LOOP STRIPS UNDER ITEM NUMBERS 33, 34, 35, AND 36. SEE ATTACHED SUPPLEMENTAL ROLL-UP SIGN ORDERING INFORMATION SHEET FOR FURTHER GUIDANCE.

ITEM NUMBER	ESTIMATED QUANTITY	DESCRIPTION	INVENTORY SUBCODE (DOH USE)	UNIT PRICE	TOTAL AMOUNT
12		EA., 14" X 17" NUMERAL OVERLAY PLAQUES FOR ITEM NUMBER 11 (SPECIFY QTY OF EACH INDIVIDUAL NUMERAL TO BE SUPPLIED)		15.09	
13	10	EA., 48" X 24" R4-14(L/R)F "ALL TRAFFIC (W/ INTERCHANGEABLE ARROW HEAD)"	010458	64.41	644.10
14		EA, 24"x30" R4-7BF "KEEP RIGHT" SIGN		49.56	
15		EA, 36"x48" R4-7BF "KEEP RIGHT" SIGN		81.35	
16		EA., 30"x18" R9-9F "SIDEWALK CLOSED"		44.66	
17	50	EA., 48"x30" R11-2F "ROAD CLOSED" W/ HOOK & LOOP FOR OVERLAY PLAQUES (ORDER "BRIDGE" AND "RAMP" OVERLAYS UNDER ITEM #18)	011110	72.26	3613.00
18	50	EA., 10" X 39" "BRIDGE" AND "RAMP" OVERLAY PLAQUES FOR ITEM 17 (SPECIFY QTY OF EACH INDIVIDUAL PLAQUE TO BE SUPPLIED)	011112 (BRIDGE) 011113 (RAMP)	19.22	961.00
19	10	EA., 60" X 30" R11-3AF "ROAD CLOSED _____ MI AHEAD LOCAL TRAFFIC ONLY" W/ HOOK & LOOP FOR NUMERAL OVERLAY PLAQUES (ORDER NUMERALS UNDER ITEM #20)	011128	85.14	851.40
20	40	EA., 5" X 7" NUMERAL OVERLAY PLAQUES FOR ITEM NUMBER 19 (SPECIFY QTY OF EACH INDIVIDUAL NUMERAL TO BE SUPPLIED)		5.25	210.00
21	10	EA., 60"x30" R11-4F "ROAD CLOSED TO THRU TRAFFIC"	011135	84.42	844.20
22		EA., 48"x36" W22-10F "EXIT _____" W/ HOOK & LOOP FOR OVERLAYS (ORDER "OPEN" AND "CLOSED" PLAQUES UNDER ITEM #23)	022260	86.08	
23		EA., 10" X 40" "OPEN" AND "CLOSED" OVERLAY PLAQUES FOR ITEM 22 (SPECIFY QTY OF EACH INDIVIDUAL PLAQUE TO BE SUPPLIED)	022261 (OPEN) 022262 (CLOSED)	14.19	
24		EA., 60"x60" W22-11F EXIT GORE SIGN	022269	199.45	
25		EA., 30"x24" M4-9F STANDARD DETOUR SIGN W/ HOOK & LOOP AND ARROW OVERLAY PLAQUE		61.83	

**ERING NOTES FOR DOH PERSONNEL:**

OND SIGNS WITH TEXT TO BEGINNING "ROAD WORK" ARE TO BE ORDERED UNDER ITEM NUMBERS 30, 32, 34, OR 36 ONLY. W20-7A AND W21-1A SIGNS ARE TO BE ORDERED UNDER ITEM NUMBERS 30 OR 32 ONLY

#24 IS TO BE INSTALLED ONLY ON THE STAND PROVIDED UNDER ITEM #2.

ATTACHED COMMISSIONERS ORDERS REGARDING THE PROPER USE OF ITEM # 11. BASED ON THESE COMMISSIONER'S ORDERS, THIS ITEM MAY BE USED ONLY ON CONTROLLED ACCESS FREEWAYS OR EXPRESSWAYS IN THE DURATION OF THE OF THE WORK ACTIVITY IS NOT TO EXCEED ONE DAYLIGHT PERIOD.

STAND SUPPLIED AS PART OF BID ITEM #2 IS NOT TO BE USED WITH ALUM SUBSTRATE SIGNS LARGER THAN 48X48 (DIAMOND), 60X30 (HORIZONTAL RECTANGLE), 36X60 (VERTICAL RECTANGLE), 48" (OCTAGON), 36X36 (SQUARE), OR 48" (TRIANGLE). CONTACT DT FOR SPECIAL NEEDS.

DIAMOND SHAPED SIGNS WHICH MAY POTENTIALLY BE ALTERED WITH OVERLAY PLAQUES ARE TO BE ORDERED WITH HOOK AND LOOP STRIPS UNDER ITEM NUMBERS 33, 34, 35, AND 36. SEE ATTACHED "PLEMENTAL ROLL-UP SIGN ORDERING INFORMATION" SHEET FOR FURTHER GUIDANCE.



ITEM NUMBER	ESTIMATED QUANTITY	DESCRIPTION	INVENTORY SUBCODE (DOH USE)	UNIT PRICE	TOTAL AMOUNT
26	10	Ea., 48"x48" EMERGENCY RESPONSE TRAILER DETOUR SIGN W/ HOOK & LOOP FOR OVERLAY PLAQUES AND ARROW OVERLAY PLAQUE (ORDER ROUTE AND CARDINAL DIRECTION PLAQUES UNDER ITEM NUMBERS 27 & 28)	114848	102.29	1022.90
27	30	Ea., 9" X 28" EMERGENCY RESPONSE TRAILER ROUTE OVERLAY PLAQUE FOR ITEM 26 (SPECIFY EACH INDIVIDUAL ROUTE PLAQUE TO BE SUPPLIED AND QTY OF EACH)	110928	14.41	432.30
28		Ea., 9" X 7" EMERGENCY RESPONSE TRAILER CARDINAL DIRECTION OVERLAY PLAQUE FOR ITEM 26 (SPECIFY QTY OF EACH "N", "S", "E", AND "W" PLAQUES TO BE SUPPLIED)	110709	10.83	
29	35	Ea., 48" x 48" DIAMOND, FLUORESCENT ORANGE, STANDARD MESSAGE ROLL-UP SIGN (SPECIFY QUANTITY OF EACH FABRICATION NUMBER TO BE SUPPLIED)		89.52	3133.20
30	570	Ea., 48" x 48" DIAMOND, FLUORESCENT ORANGE, STANDARD MESSAGE ROLL-UP SIGN, WITH PERMANENT ADDITION OF TWO (2) 18" X 18" VINYL FOLDING FLAGS. (SPECIFY QUANTITY OF EACH FABRICATION NUMBER TO BE SUPPLIED)		101.40	57798.00
31	640	Ea., 36" x 36" DIAMOND, FLUORESCENT ORANGE, STANDARD MESSAGE ROLL-UP SIGN (SPECIFY QUANTITY OF EACH FABRICATION NUMBER TO BE SUPPLIED)		65.63	42003.20
32	750	Ea., 36" x 36" DIAMOND, FLUORESCENT ORANGE, STANDARD MESSAGE ROLL-UP SIGN, WITH PERMANENT ADDITION OF TWO (2) 18"X18" VINYL FOLDING FLAGS. (SPECIFY QUANTITY OF EACH FABRICATION NUMBER TO BE SUPPLIED)		77.50	58125.00
33	85	Ea., 48" x 48" DIAMOND, FLUORESCENT ORANGE, STANDARD MESSAGE ROLL-UP SIGN WITH HOOK & LOOP STRIPS FOR OVERLAY ATTACHMENTS (SPECIFY QTY OF EACH FABRICATION NUMBER TO BE SUPPLIED AND PORTION OF TEXT INTENDED TO BE COVERED WITH OVERLAY PLAQUES - ORDER OVERLAY PLAQUES UNDER BID ITEM 37)		92.41	7854.85
34	175	Ea., 48" x 48" DIAMOND, FLUORESCENT ORANGE, STANDARD MESSAGE ROLL-UP SIGN WITH PERMANENT ADDITION OF TWO (2) 18"X18" VINYL FOLDING FLAGS, AND HOOK & LOOP STRIPS FOR OVERLAY ATTACHMENTS (SPECIFY QTY OF EACH FABRICATION NUMBER TO BE SUPPLIED AND PORTION OF TEXT INTENDED TO BE COVERED WITH OVERLAY PLAQUES - ORDER OVERLAY PLAQUES UNDER BID ITEM 37)		104.29	18250.75
35		Ea., 36" x 36" DIAMOND, FLUORESCENT ORANGE, STANDARD MESSAGE ROLL-UP SIGN WITH HOOK & LOOP STRIPS FOR OVERLAY ATTACHMENTS (SPECIFY QTY OF EACH FABRICATION NUMBER TO BE SUPPLIED AND PORTION OF TEXT INTENDED TO BE COVERED WITH OVERLAY PLAQUES - ORDER OVERLAY PLAQUES UNDER BID ITEM 38)		68.51	

**ERING NOTES FOR DOH PERSONNEL:**

DIAMOND SIGNS WITH TEXT TO BEGINNING "ROAD WORK" ARE TO BE ORDERED UNDER ITEM NUMBERS 30, 32, 34, OR 36 ONLY. W20-7A AND W21-1A SIGNS ARE TO BE ORDERED UNDER ITEM NUMBERS 30 OR 32 ONLY.

#24 IS TO BE INSTALLED ONLY ON THE STAND PROVIDED UNDER ITEM #2.

ATTACHED COMMISSIONER'S ORDERS REGARDING THE PROPER USE OF ITEM # 11. BASED ON THESE COMMISSIONER'S ORDERS, THIS ITEM MAY BE USED ONLY ON CONTROLLED ACCESS FREEWAYS OR EXPRESSWAYS IN THE DURATION OF THE OF THE WORK ACTIVITY IS NOT TO EXCEED ONE DAYLIGHT PERIOD.

STAND SUPPLIED AS PART OF BID ITEM #2 IS NOT TO BE USED WITH ALUM SUBSTRATE SIGNS LARGER THAN 48X48 (DIAMOND), 60X30 (HORIZONTAL RECTANGLE), 36X60 (VERTICAL RECTANGLE), 48" (OCTAGON), SQUARE), OR 48" (TRIANGLE). CONTACT DT FOR SPECIAL NEEDS.

DIAMOND SHAPED SIGNS WHICH MAY POTENTIALLY BE ALTERED WITH OVERLAY PLAQUES ARE TO BE ORDERED WITH HOOK AND LOOP STRIPS UNDER ITEM NUMBERS 33, 34, 35, AND 36. SEE ATTACHED "PLEMENTAL ROLL-UP SIGN ORDERING INFORMATION" SHEET FOR FURTHER GUIDANCE.

ITEM NUMBER	ESTIMATED QUANTITY	DESCRIPTION	INVENTORY SUBCODE (DOH USE)	UNIT PRICE	TOTAL AMOUNT
36	60	Ea., 36" x 36" DIAMOND, FLUORESCENT ORANGE, STANDARD MESSAGE ROLL-UP SIGN WITH PERMANENT ADDITION OF TWO (2) 18"x18" VINYL FOLDING FLAGS, AND HOOK & LOOP STRIPS FOR OVERLAY ATTACHMENTS (SPECIFY QTY OF EACH FABRICATION NUMBER TO BE SUPPLIED AND PORTION OF TEXT INTENDED TO BE COVERED WITH OVERLAY PLAQUES - ORDER OVERLAY PLAQUES UNDER BID ITEM 38)		80.39	4823.40
37	310	Ea., 8" X 21" ("LEFT" AND "CENTER" TEXT ONLY) OR 8" X 28" FLUORESCENT ORANGE OVERLAYS WITH H&L STRIPS FOR USE WITH ITEM NUMBERS 33 AND 34. EXAMPLES: LEFT, 500 FT., 1000 FT., 1500 FT., 1/2 MILE, AND 1 MILE (SPECIFY QUANTITY OF EACH PLAQUE TO BE SUPPLIED)		14.69	4553.90
38	10	Ea., 6" x 21" FLUORESCENT ORANGE OVERLAYS WITH H&L STRIPS FOR USE WITH ITEM NUMBERS 35 AND 36. EXAMPLES: LEFT, 500 FT., 1000 FT., 1500 FT., 1/2 MILE, and AHEAD (SPECIFY QUANTITY OF EACH PLAQUE TO BE SUPPLIED)		12.01	120.10
39		EA, 18"x36" G20-2 "END ROAD WORK" SIGN		46.61	

**ERING NOTES FOR DOH PERSONNEL:**

OND SIGNS WITH TEXT TO BEGINNING "ROAD WORK" ARE TO BE ORDERED UNDER ITEM NUMBERS 30, 32, 34, OR 36 ONLY. W20-7A AND W21-1A SIGNS ARE TO BE ORDERED UNDER ITEM NUMBERS 30 OR 32 ONLY #24 IS TO BE INSTALLED ONLY ON THE STAND PROVIDED UNDER ITEM #2.

ATTACHED COMMISSIONERS ORDERS REGARDING THE PROPER USE OF ITEM # 11. BASED ON THESE COMMISSIONER'S ORDERS, THIS ITEM MAY BE USED ONLY ON CONTROLLED ACCESS FREEWAYS OR EXPRESSWAYS IN THE DURATION OF THE OF THE WORK ACTIVITY IS NOT TO EXCEED ONE DAYLIGHT PERIOD.

STAND SUPPLIED AS PART OF BID ITEM #2 IS NOT TO BE USED WITH ALUM SUBSTRATE SIGNS LARGER THAN 48X48 (DIAMOND), 60X30 (HORIZONTAL RECTANGLE), 36X60 (VERTICAL RECTANGLE), 48" (OCTAGON), SQUARE), OR 48" (TRIANGLE). CONTACT DT FOR SPECIAL NEEDS.

DIAMOND SHAPED SIGNS WHICH MAY POTENTIALLY BE ALTERED WITH OVERLAY PLAQUES ARE TO BE ORDERED WITH HOOK AND LOOP STRIPS UNDER ITEM NUMBERS 33, 34, 35, AND 36. SEE ATTACHED "PLEMENTAL ROLL-UP SIGN ORDERING INFORMATION" SHEET FOR FURTHER GUIDANCE.

**SUPPLEMENTAL ROLL-UP SIGN ORDERING INFORMATION**

The following is a listing of diamond shaped signs for which alternate messages may be displayed using supplemental overlay plaques. All such signs are to be ordered with hook & loop strips under Item numbers 33, 34, 35, or 36. In addition, all such signs are to be ordered with the indicated "base" sign message being the permanent sign message. All alternate messages to the "base" sign message are to be accomplished by using the supplemental overlay plaques supplied under item numbers 37 and 38. ---

Fabrication Number	Fab Book Description	Applicable Sizes	"Base" Sign Message	Additional Notes
W4-7	THRU TRAFFIC MERGE LEFT (RIGHT)	36" and 48"	THRU TRAFFIC MERGE RIGHT	
W5-1	ROAD (LANE) (RAMP) NARROWS	36" and 48"	ROAD NARROWS	
W5-1C	NARROW ROAD (LANE) (LANES)	36" only	NARROW ROAD	
W8-9	LOW (NO) SHOULDER	36" and 48"	LOW SHOULDER	
W9-1	LEFT (RIGHT) LANE ENDS	36" and 48"	RIGHT LANE ENDS	
W20-1	ROAD WORK AHEAD (VARIOUS ALTERNATE MESSAGES)	36" only	ROAD WORK AHEAD	Use Item #36
W20-1	ROAD WORK AHEAD (VARIOUS ALTERNATE MESSAGES)	48"	ROAD WORK 1 MILE	Use Item #34 No 8x28 "AHEAD" plaques are to be ordered for use with this sign
W20-2	DETOUR 1000 FT (VARIOUS ALTERNATE MESSAGES)	36" and 48"	DETOUR 1000 FT	No 8x28 "AHEAD" plaques are to be ordered for use with this sign in the 48" size
W20-3	ROAD CLOSED 1000 FT (VARIOUS ALTERNATE MESSAGES)	36" and 48"	ROAD CLOSED 1000 FT	No 8x28 "AHEAD" plaques are to be ordered for use with this sign in the 48" size
W20-4	ONE LANE ROAD 1000 FT (VARIOUS ALTERNATE MESSAGES)	36" and 48"	ONE LANE ROAD 1000 FT	No 8x28 "AHEAD" plaques are to be ordered for use with this sign in the 48" size
W20-5	RIGHT (LEFT) (CENTER) LANE CLOSED 1500 FT (VARIOUS ALTERNATE MESSAGES)	36" and 48"	RIGHT LANE CLOSED 1500 FT	No 8x28 "AHEAD" plaques are to be ordered for use with this sign in the 48" size
W20-5A	RIGHT (LEFT) TWO LANES CLOSED 1500 FT (VARIOUS ALTERNATE MESSAGES)	36" and 48"	RIGHT TWO LANES CLOSED 1500 FT	No 8x28 "AHEAD" plaques are to be ordered for use with this sign in the 48" size
W20-10	SHOULDER CLOSED 1000 FT (VARIOUS ALTERNATE MESSAGES)	36" and 48"	SHOULDER CLOSED 1000 FT	No 8x28 "AHEAD" plaques are to be ordered for use with this sign in the 48" size
W20-11	LANE SHIFT 1000 FT (VARIOUS ALTERNATE MESSAGES)	36" and 48"	LANE SHIFT 1000 FT	No 8x28 "AHEAD" plaques are to be ordered for use with this sign in the 48" size
W21-5A	RIGHT (LEFT) SHOULDER CLOSED	36" and 48"	RIGHT SHOULDER CLOSED	
W21-5B	RIGHT (LEFT) SHOULDER CLOSED 1000 FT (VARIOUS ALTERNATE MESSAGES)	36" and 48"	RIGHT SHOULDER CLOSED 1000 FT	No 8x28 "AHEAD" plaques are to be ordered for use with this sign in the 48" size
W21-5C	SHOULDER WORK AHEAD (VARIOUS ALTERNATE MESSAGES)	36" only	SHOULDER WORK AHEAD	
W21-5C	SHOULDER WORK AHEAD (VARIOUS ALTERNATE MESSAGES)	48"	SHOULDER WORK 500 FT.	No 8x28 "AHEAD" plaques are to be ordered for use with this sign
W21-7	UTILITY WORK AHEAD (VARIOUS ALTERNATE MESSAGES)	36" only	UTILITY WORK AHEAD	
W21-7	UTILITY WORK AHEAD (VARIOUS ALTERNATE MESSAGES)	48"	UTILITY WORK 1 MILE	No 8x28 "AHEAD" plaques are to be ordered for use with this sign
W22-1	BLASTING ZONE AHEAD (VARIOUS ALTERNATE MESSAGES)	36" only	BLASTING ZONE AHEAD	
W22-1	BLASTING ZONE AHEAD (VARIOUS ALTERNATE MESSAGES)	48"	BLASTING ZONE 1500 FT.	No 8x28 "AHEAD" plaques are to be ordered for use with this sign

**PRODUCT COMPLIANCE CHECKLIST FORM**

This form shall be completed in its' entirety by the vendor, and submitted as part of the vendor's bid package.

**SECTION I - ITEM #1 - COMPACT PORTABLE SIGN STAND**

1) This section not applicable (this item is not being bid)?

Yes
-----

2) Stand manufacturer: Eastern Metal

3) Stand trade name and model number: C-902-DD

4) Stand is FHWA approved as meeting all applicable NCHRP-350 or MASH crash testing requirements when used with all signs described under bid items 3 through 39 (except Item #24), and on all roadways (Speed Limit 25 MPH to 70 MPH)?

Yes	No
<input checked="" type="checkbox"/>	<input type="checkbox"/>

5) List all applicable individual FHWA acceptance letter reference numbers below for which statement #4 is based on.

W2-07 W2-56  
W2-13

6) Stand capable of holding 36" and 48" diamond roll-up signs a minimum of 12" off the ground?

Yes	No
<input checked="" type="checkbox"/>	<input type="checkbox"/>

7) By bidding this Contract, Vendor agrees to extend to the WVDOH a four (4) year warranty against defects in workmanship, parts, and materials?

Yes	No
<input checked="" type="checkbox"/>	<input type="checkbox"/>

PRINT NAME: Lisa P. Booth

SIGN NAME: Lisa P Booth

NAME OF VENDOR: Highway Safety Inc

DATE: 9-7-10

**PRODUCT COMPLIANCE CHECKLIST FORM**

This form shall be completed in its' entirety by the vendor, and submitted as part of the vendor's bid package.

**SECTION II - ITEM #2 - LARGE, ALUMINUM SUBSTRATE SIGN AND OVERSIZED ROLL-UP SIGN PORTABLE SIGN STAND**

1) This section not applicable (this item is not being bid)?

Yes
-----

2) Stand manufacturer: Eastern Metal

3) Stand trade name and model number: X-553-DD

4) Stand is FHWA approved as meeting all applicable NCHRP-350 or MASH crash testing requirements when used with all signs described under bid items 3 through 39, and 80 ga aluminum substrate signs not larger than 48X48 (DIAMOND), 60X30 (HORIZONTAL RECTANGLE), 36X60 (VERTICAL RECTANGLE), 48" (OCTAGON), 48" (SQUARE), OR 48" (TRIANGLE), and on all roadways (Speed Limit 25 MPH to 70 MPH)?

Yes	No
<input checked="" type="checkbox"/>	<input type="checkbox"/>

5) List all applicable individual FHWA acceptance letter reference numbers below for which statement #4 is based on.

W2-07                      W2-56  
W2-13

6) Stand, as supplied, capable of holding 0.080 aluminum 48" diamond signs, 48" octagon signs, 48" triangle signs, 36x60 vertical rectangle signs, 60x30 horizontal rectangle signs, and smaller signs, as well as roll-up signs as large as 60x60 square?

Yes	No
<input checked="" type="checkbox"/>	<input type="checkbox"/>

7) Stand designed such that the sign mounting height will be 12 in to 24 in off of the ground?

Yes	No
<input checked="" type="checkbox"/>	<input type="checkbox"/>

8) Stand to be supplied with a adjustable mast, adjustable brackets for rigid signs, and an adjustable roll-up sign bracket?

Yes	No
<input checked="" type="checkbox"/>	<input type="checkbox"/>

9) Supplied roll-up sign bracket accommodates all of the horizontal rib sizes detailed as part of this Contract?

Yes	No
<input checked="" type="checkbox"/>	<input type="checkbox"/>

10) By bidding this Contract, Vendor agrees to extend to the WVDOH a four (4) year warranty against defects in workmanship, parts, and materials?

Yes	No
<input checked="" type="checkbox"/>	<input type="checkbox"/>

PRINT NAME: Lisa P. Booth

SIGN NAME: Lisa P Booth

NAME OF VENDOR: Highway Safety Inc.

DATE: 9-7-10

# PRODUCT COMPLIANCE CHECKLIST FORM

This form shall be completed in its' entirety by the vendor, and submitted as part of the vendor's bid package.

**SECTION III - ITEMS 3 THROUGH 39 - ROLL-UP SIGNS**

1) This section not applicable (these items not being bid)?

Yes

2) Sign manufacturer: Eastern Metal

3) Sheeting manufacturer and product code for sheeting being used: 3M RS24

4) Sign manufacturer is certified by the sheeting manufacturer for manufacturing traffic signs using the sheeting manufacturer's material?

Yes	No
<input checked="" type="checkbox"/>	

5) In cases where the splicing of roll-up sign material fabric is required as noted within the Contract specifications, the splice is to be accomplished by the method described within the Contract specifications?

Yes	No
<input checked="" type="checkbox"/>	

6) All vertical, horizontal, or diagonal ribs designed to pivot about a metallic (rivet) pivot point meeting the specifications herein?

Yes	No
<input checked="" type="checkbox"/>	

7) With the exception of the vertical rib of non-diamond signs (excluding stop signs), the ends of the ribs on all signs to slide into a cloth pocket meeting the material, manufacturing, and dimensional requirements contained herein?

Yes	No
<input checked="" type="checkbox"/>	

8) Vertical ribs of all non-diamond signs (excluding stop signs) to be attached and secured to signs using Hook & Loop material as described herein?

Yes	No
<input checked="" type="checkbox"/>	

9) All metal parts of the vinyl flag deployment system, when required, to be stainless steel, electro-deposit zinc coated steel, hot-dip galvanized steel, or powder coated steel?

Yes	No
<input checked="" type="checkbox"/>	

10) Flag staffs made using fiberglass or other material similar to the sign ribs, and have a minimum section modulus equal to that of a 1/8" thick x 1" wide rib (0.002604 in ^ 3)?

Yes	No
<input checked="" type="checkbox"/>	

11) Flag staffs sufficiently long enough to hold the flags completely above the sign face?

Yes	No
<input checked="" type="checkbox"/>	

12) No hand tightening of any components required to hold the flags in the deployed position?

Yes	No
<input checked="" type="checkbox"/>	

13) When deployed, the two flags extend symmetrically (about the vertical centerline) up and out from their mounting point along the vertical rib, with the flags held in position completely above the sign face, and with each staff at an angle of 30 to 60 degrees from the vertical centerline of the sign?

Yes	No
<input checked="" type="checkbox"/>	

14) For particular signs and overlay plaques requiring hook and loop (H&L) strips for temporary overlay attachment, the hook ("coarse") side of the H&L is attached to the sign faces, and the loop ("fuzzy") side of the H&L is attached to the back face of the overlays?

Yes	No
<input checked="" type="checkbox"/>	

15) All signs to present a finished, professional look to the motorist with no sagging of the sign material?

Yes	No
<input checked="" type="checkbox"/>	

16) Signs to include anti-kite H&L loops attached to the back faces of the signs for connection around the ribs of the signs (manufacturer shall determine appropriate locations for anti-kite H&L strips)?

Yes	No
<input checked="" type="checkbox"/>	

17) H&L material to be fastened near the vertical center of one of the horizontal end points on each sign, and to be oriented such that when the sign is rolled up on the vertical rib the H&L material will encircle the sign and hold it in the rolled up storing position?

Yes	No
<input checked="" type="checkbox"/>	

18) All signs to have a permanent sticker affixed to the non-reflective face with the wording "PROPERTY OF WVDOH" in 1/2" minimum legend size?

Yes	No
<input checked="" type="checkbox"/>	

19) Rib sizes, rib locations, rib lengths, corner pocket locations, and rotation point locations to be in substantial conformance as shown in the supplemental drawings included within the Contract?

Yes	No
<input checked="" type="checkbox"/>	

20) Identification to be printed in the margin for convenient indication of the sign message when the sign is rolled up for storage?

Yes	No
<input checked="" type="checkbox"/>	

PRINT NAME: Lisa P. Booth

SIGN NAME: Gron P Booth

NAME OF VENDOR: Highway Safety Inc.

DATE: 9-2-10

# State of West Virginia VENDOR PREFERENCE CERTIFICATE

Certification and application\* is hereby made for Preference in accordance with *West Virginia Code*, §5A-3-37. (Does not apply to construction contracts). *West Virginia Code*, §5A-3-37, provides an opportunity for qualifying vendors to request (at the time of bid) preference for their residency status. Such preference is an evaluation method only and will be applied only to the cost bid in accordance with the *West Virginia Code*. This certificate for application is to be used to request such preference. The Purchasing Division will make the determination of the Resident Vendor Preference, if applicable.

- 1. Application is made for 2.5% resident vendor preference for the reason checked:  
 Bidder is an individual resident vendor and has resided continuously in West Virginia for four (4) years immediately preceding the date of this certification; or,  
 Bidder is a partnership, association or corporation resident vendor and has maintained its headquarters or principal place of business continuously in West Virginia for four (4) years immediately preceding the date of this certification; or 80% of the ownership interest of Bidder is held by another individual, partnership, association or corporation resident vendor who has maintained its headquarters or principal place of business continuously in West Virginia for four (4) years immediately preceding the date of this certification; or,  
 Bidder is a nonresident vendor which has an affiliate or subsidiary which employs a minimum of one hundred state residents and which has maintained its headquarters or principal place of business within West Virginia continuously for the four (4) years immediately preceding the date of this certification; or,
- 2. Application is made for 2.5% resident vendor preference for the reason checked:  
 Bidder is a resident vendor who certifies that, during the life of the contract, on average at least 75% of the employees working on the project being bid are residents of West Virginia who have resided in the state continuously for the two years immediately preceding submission of this bid; or,
- 3. Application is made for 2.5% resident vendor preference for the reason checked:  
 Bidder is a nonresident vendor employing a minimum of one hundred state residents or is a nonresident vendor with an affiliate or subsidiary which maintains its headquarters or principal place of business within West Virginia employing a minimum of one hundred state residents who certifies that, during the life of the contract, on average at least 75% of the employees or Bidder's affiliate's or subsidiary's employees are residents of West Virginia who have resided in the state continuously for the two years immediately preceding submission of this bid; or,
- 4. Application is made for 5% resident vendor preference for the reason checked:  
 Bidder meets either the requirement of both subdivisions (1) and (2) or subdivision (1) and (3) as stated above; or,
- 5. Application is made for 3.5% resident vendor preference who is a veteran for the reason checked:  
 Bidder is an individual resident vendor who is a veteran of the United States armed forces, the reserves or the National Guard and has resided in West Virginia continuously for the four years immediately preceding the date on which the bid is submitted; or,
- 6. Application is made for 3.5% resident vendor preference who is a veteran for the reason checked:  
 Bidder is a resident vendor who is a veteran of the United States armed forces, the reserves or the National Guard, if, for purposes of producing or distributing the commodities or completing the project which is the subject of the vendor's bid and continuously over the entire term of the project, on average at least seventy-five percent of the vendor's employees are residents of West Virginia who have resided in the state continuously for the two immediately preceding years.

Bidder understands if the Secretary of Revenue determines that a Bidder receiving preference has failed to continue to meet the requirements for such preference, the Secretary may order the Director of Purchasing to: (a) reject the bid; or (b) assess a penalty against such Bidder in an amount not to exceed 5% of the bid amount and that such penalty will be paid to the contracting agency or deducted from any unpaid balance on the contract or purchase order.

By submission of this certificate, Bidder agrees to disclose any reasonably requested information to the Purchasing Division and authorizes the Department of Revenue to disclose to the Director of Purchasing appropriate information verifying that Bidder has paid the required business taxes, provided that such information does not contain the amounts of taxes paid nor any other information deemed by the Tax Commissioner to be confidential.

Under penalty of law for false swearing (*West Virginia Code*, §61-5-3), Bidder hereby certifies that this certificate is true and accurate in all respects; and that if a contract is issued to Bidder and if anything contained within this certificate changes during the term of the contract, Bidder will notify the Purchasing Division in writing immediately.

Bidder: Highway Safety Inc  
Date: 9-7-10

Signed: Leon P Booth  
Title: President

\*Check any combination of preference consideration(s) indicated above, which you are entitled to receive.

STATE OF WEST VIRGINIA  
Purchasing Division

**PURCHASING AFFIDAVIT**

West Virginia Code §5A-3-10a states: No contract or renewal of any contract may be awarded by the state or any of its political subdivisions to any vendor or prospective vendor when the vendor or prospective vendor or a related party to the vendor or prospective vendor is a debtor and the debt owed is an amount greater than one thousand dollars in the aggregate.

**DEFINITIONS:**

"Debt" means any assessment, premium, penalty, fine, tax or other amount of money owed to the state or any of its political subdivisions because of a judgment, fine, permit violation, license assessment, defaulted workers' compensation premium, penalty or other assessment presently delinquent or due and required to be paid to the state or any of its political subdivisions, including any interest or additional penalties accrued thereon.

"Debtor" means any individual, corporation, partnership, association, limited liability company or any other form or business association owing a debt to the state or any of its political subdivisions. "Political subdivision" means any county commission; municipality; county board of education; any instrumentality established by a county or municipality; any separate corporation or instrumentality established by one or more counties or municipalities, as permitted by law; or any public body charged by law with the performance of a government function or whose jurisdiction is coextensive with one or more counties or municipalities. "Related party" means a party, whether an individual, corporation, partnership, association, limited liability company or any other form or business association or other entity whatsoever, related to any vendor by blood, marriage, ownership or contract through which the party has a relationship of ownership or other interest with the vendor so that the party will actually or by effect receive or control a portion of the benefit, profit or other consideration from performance of a vendor contract with the party receiving an amount that meets or exceeds five percent of the total contract amount.

**EXCEPTION:** The prohibition of this section does not apply where a vendor has contested any tax administered pursuant to chapter eleven of this code, workers' compensation premium, permit fee or environmental fee or assessment and the matter has not become final or where the vendor has entered into a payment plan or agreement and the vendor is not in default of any of the provisions of such plan or agreement.

Under penalty of law for false swearing (*West Virginia Code §61-5-3*), it is hereby certified that the vendor affirms and acknowledges the information in this affidavit and is in compliance with the requirements as stated.

**WITNESS THE FOLLOWING SIGNATURE**

Vendor's Name: Highway Safety Inc

Authorized Signature: [Signature] Date: 9-7-10

State of WV

County of Wayne, to-wit:

Taken, subscribed, and sworn to before me this 7th day of September, 2010.

My Commission expires October 4, 2010.

AFFIX SEAL HERE

NOTARY PUBLIC [Signature]

