



State of West Virginia  
 Department of Administration  
 Purchasing Division  
 2019 Washington Street East  
 Post Office Box 50130  
 Charleston, WV 25305-0130

# Request for Quotation

RFQ NUMBER
7011EC21

PAGE
1

ADDRESS CORRESPONDENCE TO ATTENTION OF
BUYER 33 304-558-2402

VENDOR

\*709015804      724-437-1578  
 UNIONTOWN INDUSTRIAL EQUIP CO  
 2266 UNIVERSITY DR  
 LEMONT FURNACE PA 15478

SHIP TO

DIVISION OF HIGHWAYS  
 EQUIPMENT DIVISION  
 ROUTE 33  
 BRUSHY FORK ROAD  
 BUCKHANNON, WV  
 26201      304-472-1750

DATE PRINTED	TERMS OF SALE	SHIP VIA	F.O.B.	FREIGHT TERMS
04/04/2011				

BID OPENING DATE: 06/01/2011      BID OPENING TIME 01:30PM

LINE	QUANTITY	UOP	CAT NO	ITEM NUMBER	UNIT PRICE	AMOUNT
0001	1	EA		975-66	\$71,500.00	\$71,500.00
<p>ALL WHEEL DRIVE LOADER WITH BACKHOE</p> <p>REQUEST FOR QUOTATION (RFQ) OPEN END CONTRACT</p> <p>THE WEST VIRGINIA STATE PURCHASING DIVISION FOR THE AGENCY, THE WEST VIRGINIA DIVISION OF HIGHWAYS, IS SOLICITING BIDS FOR AN OPEN END CONTRACT TO PROVIDE ALL WHEEL DRIVE LOADER WITH BACKHOE WHEEL TYPE PER THE ATTACHED SPECIFICATIONS.</p> <p>TECHNICAL QUESTIONS CONCERNING THIS SOLICITATION WILL BE RECEIVED THROUGH THE CLOSE OF THE MANDATORY PRE-BID MEETING. TECHNICAL QUESTIONS MUST BE SUBMITTED IN WRITING TO SHERI SLONE WEST VIRGINIA STATE PURCHASING DIVISION. VENDORS MAY SUBMIT QUESTIONS PRIOR TO THE MANDATORY PRE-BID VIA MAIL AT THE ADDRESS LISTED IN THE BODY OF THIS RFQ, VIA FAX AT 305-558-4115; OR VIA EMAIL AT SHERI.D.SLONE@WV.GOV. WRITTEN QUESTIONS WILL ALSO BE ACCEPTED DURING THE MANDATORY PRE-BID. DEADLINE FOR ALL TECHNICAL QUESTIONS IS THE CLOSE OF THE PRE-BID MEETING. NO ADDITIONAL QUESTIONS WILL BE ACCEPTED AFTER THE PRE-BID MEETING. ANY TECHNICAL QUESTIONS RECEIVED WILL BE ANSWERED BY FORMAL ADDENDUM TO BE ISSUED BY THE PURCHASING DIVISION AFTER THE MANDATORY PRE-BID MEETING. FOR YOUR CONVENIENCE A WORD DOCUMENT HAS BEEN ATTACHED FOR SUBMITTING TECHNICAL QUESTIONS.</p>						

RECEIVED  
 JUN 14 A 10:07

SIGNATURE		TELEPHONE		DATE
<i>Michael W. [Signature]</i>		(724) 437-1578		6/11/2011
TITLE	FEIN	ADDRESS CHANGES TO BE NOTED ABOVE		
V. President	25-1389795			

WHEN RESPONDING TO RFQ, INSERT NAME AND ADDRESS IN SPACE ABOVE LABELED 'VENDOR'

**GENERAL TERMS & CONDITIONS**  
**REQUEST FOR QUOTATION (RFQ) AND REQUEST FOR PROPOSAL (RFP)**

1. Awards will be made in the best interest of the State of West Virginia.
2. The State may accept or reject in part, or in whole, any bid.
3. Prior to any award, the apparent successful vendor must be properly registered with the Purchasing Division and have paid the required \$125 fee.
4. All services performed or goods delivered under State Purchase Order/Contracts are to be continued for the term of the Purchase Order/Contracts, contingent upon funds being appropriated by the Legislature or otherwise being made available. In the event funds are not appropriated or otherwise available for these services or goods this Purchase Order/Contract becomes void and of no effect after June 30.
5. Payment may only be made after the delivery and acceptance of goods or services.
6. Interest may be paid for late payment in accordance with the *West Virginia Code*.
7. Vendor preference will be granted upon written request in accordance with the *West Virginia Code*.
8. The State of West Virginia is exempt from federal and state taxes and will not pay or reimburse such taxes.
9. The Director of Purchasing may cancel any Purchase Order/Contract upon 30 days written notice to the seller.
10. The laws of the State of West Virginia and the *Legislative Rules* of the Purchasing Division shall govern the purchasing process.
11. Any reference to automatic renewal is hereby deleted. The Contract may be renewed only upon mutual written agreement of the parties.
12. **BANKRUPTCY:** In the event the vendor/contractor files for bankruptcy protection, the State may deem this contract null and void, and terminate such contract without further order.
13. **HIPAA BUSINESS ASSOCIATE ADDENDUM:** The West Virginia State Government HIPAA Business Associate Addendum (BAA), approved by the Attorney General, is available online at [www.state.wv.us/admin/purchase/vrc/hipaa.htm](http://www.state.wv.us/admin/purchase/vrc/hipaa.htm) and is hereby made part of the agreement. Provided that the Agency meets the definition of a Cover Entity (45 CFR §160.103) and will be disclosing Protected Health Information (45 CFR §160.103) to the vendor.
14. **CONFIDENTIALITY:** The vendor agrees that he or she will not disclose to anyone, directly or indirectly, any such personally identifiable information or other confidential information gained from the agency, unless the individual who is the subject of the information consents to the disclosure in writing or the disclosure is made pursuant to the agency's policies, procedures, and rules. Vendor further agrees to comply with the Confidentiality Policies and Information Security Accountability Requirements, set forth in <http://www.state.wv.us/admin/purchase/privacy/noticeConfidentiality.pdf>.
15. **LICENSING:** Vendors must be licensed and in good standing in accordance with any and all state and local laws and requirements by any state or local agency of West Virginia, including, but not limited to, the West Virginia Secretary of State's Office, the West Virginia Tax Department, and the West Virginia Insurance Commission. The vendor must provide all necessary releases to obtain information to enable the director or spending unit to verify that the vendor is licensed and in good standing with the above entities.
16. **ANTITRUST:** In submitting a bid to any agency for the State of West Virginia, the bidder offers and agrees that if the bid is accepted the bidder will convey, sell, assign or transfer to the State of West Virginia all rights, title and interest in and to all causes of action it may now or hereafter acquire under the antitrust laws of the United States and the State of West Virginia for price fixing and/or unreasonable restraints of trade relating to the particular commodities or services purchased or acquired by the State of West Virginia. Such assignment shall be made and become effective at the time the purchasing agency tenders the initial payment to the bidder.

I certify that this bid is made without prior understanding, agreement, or connection with any corporation, firm, limited liability company, partnership, or person or entity submitting a bid for the same material, supplies, equipment or services and is in all respects fair and without collusion or fraud. I further certify that I am authorized to sign the certification on behalf of the bidder or this bid.

**INSTRUCTIONS TO BIDDERS**

1. Use the quotation forms provided by the Purchasing Division. Complete all sections of the quotation form.
2. Items offered must be in compliance with the specifications. Any deviation from the specifications must be clearly indicated by the bidder. Alternates offered by the bidder as **EQUAL** to the specifications must be clearly defined. A bidder offering an alternate should attach complete specifications and literature to the bid. The Purchasing Division may waive minor deviations to specifications.
3. Unit prices shall prevail in case of discrepancy. All quotations are considered F.O.B. destination unless alternate shipping terms are clearly identified in the quotation.
4. All quotations must be delivered by the bidder to the office listed below prior to the date and time of the bid opening. Failure of the bidder to deliver the quotations on time will result in bid disqualifications: Department of Administration, Purchasing Division, 2019 Washington Street East, P.O. Box 50130, Charleston, WV 25305-0130
5. Communication during the solicitation, bid, evaluation or award periods, except through the Purchasing Division, is strictly prohibited (W.Va. C.S.R. §148-1-6.6).



State of West Virginia  
 Department of Administration  
 Purchasing Division  
 2019 Washington Street East  
 Post Office Box 50130  
 Charleston, WV 25305-0130

# Request for Quotation

RFQ NUMBER
7011EC21

PAGE
2

ADDRESS CORRESPONDENCE TO ATTENTION OF
BUYER 33 304-558-2402

DIVISION OF HIGHWAYS  
 EQUIPMENT DIVISION  
 ROUTE 33  
 BRUSHY FORK ROAD  
 BUCKHANNON, WV  
 26201 304-472-1750

\*709015804 724-437-1578  
 UNIONTOWN INDUSTRIAL EQUIP CO  
 2266 UNIVERSITY DR

LEMONT FURNACE PA 15478

VENDOR

SHIP TO

DATE PRINTED	TERMS OF SALE	SHIP VIA	F.O.B.	FREIGHT TERMS
04/04/2011				

BID OPENING DATE: 06/01/2011 BID OPENING TIME 01:30PM

LINE	QUANTITY	UOP	CAT NO	ITEM NUMBER	UNIT PRICE	AMOUNT
MANDATORY PRE-BID						
<p>A MANDATORY PRE-BID WILL BE HELD ON TUESDAY 05/17/2011 AT 10 AM, BRUSHY FORK RD IN BUCKHANNON, WV 26201. ALL INTERESTED PARTIES ARE REQUIRED TO ATTEND THIS MEETING. FAILURE TO ATTEND THE MANDATORY PRE-BID SHALL RESULT IN DISQUALIFICATION OF THE BID. NO ONE PERSON MAY REPRESENT MORE THAN ONE BIDDER.</p> <p>AN ATTENDANCE SHEET WILL BE MADE AVAILABLE FOR ALL POTENTIAL BIDDERS TO COMPLETE. THIS WILL SERVE AS THE OFFICIAL DOCUMENT VERIFYING ATTENDANCE AT THE MANDATORY PRE-BID. FAILURE TO PROVIDE YOUR COMPANY AND REPRESENTATIVE NAME ON THE ATTENDANCE SHEET WILL RESULT IN DISQUALIFICATION OF THE BID. THE STATE WILL NOT ACCEPT ANY OTHER DOCUMENTATION TO VERIFY ATTENDANCE. THE BIDDER IS RESPONSIBLE FOR ENSURING THEY HAVE COMPLETED THE INFORMATION REQUIRED ON THE ATTENDANCE SHEET. THE PURCHASING DIVISION AND THE STATE AGENCY WILL NOT ASSUME ANY RESPONSIBILITY FOR A BIDDER-S FAILURE TO COMPLETE THE PRE-BID ATTENDANCE SHEET. IN ADDITION, WE REQUEST THAT ALL POTENTIAL BIDDERS INCLUDE THEIR E-MAIL ADDRESS AND FAX NUMBER.</p> <p>ALL POTENTIAL BIDDERS ARE REQUESTED TO ARRIVE PRIOR TO THE STARTING TIME FOR THE PRE-BID. BIDDERS WHO ARRIVE LATE, BUT PRIOR TO THE DISMISSAL OF THE TECHNICAL PORTION OF THE PRE-BID WILL BE PERMITTED TO SIGN IN. BIDDERS WHO ARRIVE AFTER CONCLUSION OF THE TECHNICAL PORTION OF THE PRE-BID, BUT DURING ANY SUBSEQUENT PART OF THE PRE-BID WILL NOT BE PERMITTED TO SIGN THE ATTENDANCE SHEET.</p> <p>EXHIBIT 10</p>						

SEE REVERSE SIDE FOR TERMS AND CONDITIONS			
SIGNATURE	TELEPHONE	DATE	
<i>Michael W. [Signature]</i>	(724) 437-1578	6/11/2011	
TITLE	FEIN	ADDRESS CHANGES TO BE NOTED ABOVE	
V. President	25-1389795		

WHEN RESPONDING TO RFQ, INSERT NAME AND ADDRESS IN SPACE ABOVE LABELED 'VENDOR'



State of West Virginia  
 Department of Administration  
 Purchasing Division  
 2019 Washington Street East  
 Post Office Box 50130  
 Charleston, WV 25305-0130

# Request for Quotation

RFQ NUMBER
7011EC21

PAGE
3

ADDRESS CORRESPONDENCE TO ATTENTION OF
BUYER 33 304-558-2402

VENDOR

\*709015804      724-437-1578  
 UNIONTOWN INDUSTRIAL EQUIP CO  
 2266 UNIVERSITY DR  
  
 LEMONT FURNACE PA 15478

SHIP TO

DIVISION OF HIGHWAYS  
 EQUIPMENT DIVISION  
 ROUTE 33  
 BRUSHY FORK ROAD  
 BUCKHANNON, WV  
 26201      304-472-1750

DATE PRINTED	TERMS OF SALE	SHIP VIA	F.O.B.	FREIGHT TERMS
04/04/2011				

BID OPENING DATE: **06/01/2011**      BID OPENING TIME **01:30PM**

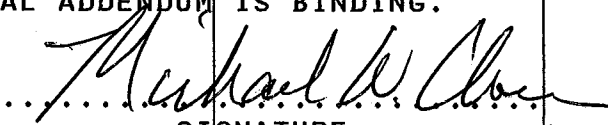
LINE	QUANTITY	UOP	CAT NO.	ITEM NUMBER	UNIT PRICE	AMOUNT
REQUISITION NO.: ...7011EC21...						
ADDENDUM ACKNOWLEDGEMENT						
I HEREBY ACKNOWLEDGE RECEIPT OF THE FOLLOWING CHECKED ADDENDUM(S) AND HAVE MADE THE NECESSARY REVISIONS TO MY PROPOSAL, PLANS AND/OR SPECIFICATION, ETC.						
ADDENDUM NO.'S:						
NO. 1 ... <input checked="" type="checkbox"/> ...						
NO. 2 .....						
NO. 3 .....						
NO. 4 .....						
NO. 5 .....						
I UNDERSTAND THAT FAILURE TO CONFIRM THE RECEIPT OF THE ADDENDUM(S) MAY BE CAUSE FOR REJECTION OF BIDS.						
VENDOR MUST CLEARLY UNDERSTAND THAT ANY VERBAL REPRESENTATION MADE OR ASSUMED TO BE MADE DURING ANY ORAL DISCUSSION HELD BETWEEN VENDOR'S REPRESENTATIVES AND ANY STATE PERSONNEL IS NOT BINDING. ONLY THE INFORMATION ISSUED IN WRITING AND ADDED TO THE SPECIFICATIONS BY AN OFFICIAL ADDENDUM IS BINDING.						
 SIGNATURE						
Uniontown Industrial Equip Co Inc.						

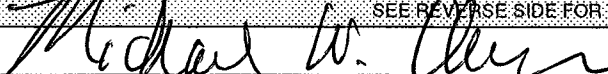
SEE REVERSE SIDE FOR TERMS AND CONDITIONS		
SIGNATURE	TELEPHONE	DATE
	(724) 437-1578	6/10/11
TITLE	FEIN	ADDRESS CHANGES TO BE NOTED ABOVE
V. President	25-1389795	

WHEN RESPONDING TO RFQ, INSERT NAME AND ADDRESS IN SPACE ABOVE LABELED 'VENDOR'



State of West Virginia  
 Department of Administration  
 Purchasing Division  
 2019 Washington Street East  
 Post Office Box 50130  
 Charleston, WV 25305-0130

# Request for Quotation

RFQ NUMBER  
**7011EC21**

PAGE  
**4**

ADDRESS CORRESPONDENCE TO ATTENTION OF  
**BUYER 33**  
**304-558-2402**

VENDOR

\*709015804      724-437-1578  
 UNIONTOWN INDUSTRIAL EQUIP CO  
 2266 UNIVERSITY DR  
 LEMONT FURNACE PA 15478

SHIP TO

DIVISION OF HIGHWAYS  
 EQUIPMENT DIVISION  
 ROUTE 33  
 BRUSHY FORK ROAD  
 BUCKHANNON, WV  
 26201      304-472-1750

DATE PRINTED	TERMS OF SALE	SHIP VIA	F.O.B	FREIGHT TERMS
04/04/2011				

BID OPENING DATE: **06/01/2011**      BID OPENING TIME **01:30PM**

LINE	QUANTITY	UOP	CAT. NO.	ITEM NUMBER	UNIT PRICE	AMOUNT
<p>COMPANY</p> <p>... June 10, 2011 .....</p> <p>DATE</p>						
<p>NOTE: THIS ADDENDUM ACKNOWLEDGEMENT SHOULD BE SUBMITTED WITH THE BID.</p> <p>REV. 09/21/2009</p> <p>EXHIBIT 2</p> <p>LIFE OF CONTRACT: THIS CONTRACT BECOMES EFFECTIVE UPON AWARD AND EXTENDS FOR A PERIOD OF ONE (1) YEAR OR UNTIL SUCH "REASONABLE TIME" THEREAFTER AS IS NECESSARY TO OBTAIN A NEW CONTRACT OR RENEW THE ORIGINAL CONTRACT. THE "REASONABLE TIME" PERIOD SHALL NOT EXCEED TWELVE (12) MONTHS. DURING THIS "REASONABLE TIME" THE VENDOR MAY TERMINATE THIS CONTRACT FOR ANY REASON UPON GIVING THE DIRECTOR OF PURCHASING THIRTY (30) DAYS WRITTEN NOTICE.</p> <p>UNLESS SPECIFIC PROVISIONS ARE STIPULATED IN THIS CONTRACT DOCUMENT, THE TERMS, CONDITIONS, AND PRICING SET HEREIN ARE FIRM FOR THE LIFE OF THE CONTRACT.</p> <p>RENEWAL: THIS CONTRACT MAY BE RENEWED UPON THE MUTUAL WRITTEN CONSENT OF THE SPENDING UNIT AND VENDOR, SUBMITTED TO THE DIRECTOR OF PURCHASING THIRTY (30) DAYS PRIOR TO THE EXPIRATION DATE. SUCH RENEWAL SHALL BE IN ACCORDANCE WITH THE TERMS AND CONDITIONS OF THE ORIGINAL CONTRACT AND SHALL BE LIMITED TO TWO (2) ONE (1) YEAR PERIODS.</p>						

SEE REVERSE SIDE FOR TERMS AND CONDITIONS

SIGNATURE <i>Michael W. [Signature]</i>	TELEPHONE (724) 437-1578	DATE 6/10/11
TITLE V. President	FEIN 25-1389795	ADDRESS CHANGES TO BE NOTED ABOVE

WHEN RESPONDING TO RFQ, INSERT NAME AND ADDRESS IN SPACE ABOVE LABELED 'VENDOR'



State of West Virginia  
 Department of Administration  
 Purchasing Division  
 2019 Washington Street East  
 Post Office Box 50130  
 Charleston, WV 25305-0130

# Request for Quotation

RFO NUMBER
7011EC21

PAGE
5

ADDRESS CORRESPONDENCE TO ATTENTION OF
BUYER 33 304-558-2402

**VENDOR**  
 \*709015804      724-437-1578  
 UNIONTOWN INDUSTRIAL EQUIP CO  
 2266 UNIVERSITY DR  
 LEMONT FURNACE PA 15478

**SHIP TO**  
 DIVISION OF HIGHWAYS  
 EQUIPMENT DIVISION  
 ROUTE 33  
 BRUSHY FORK ROAD  
 BUCKHANNON, WV  
 26201      304-472-1750

DATE PRINTED	TERMS OF SALE	SHIP VIA	F.O.B	FREIGHT TERMS
04/04/2011				

BID OPENING DATE: **06/01/2011**      BID OPENING TIME **01:30PM**

LINE	QUANTITY	UOP	CAT NO	ITEM NUMBER	UNIT PRICE	AMOUNT
<p><b>CANCELLATION:</b> THE DIRECTOR OF PURCHASING RESERVES THE RIGHT TO CANCEL THIS CONTRACT IMMEDIATELY UPON WRITTEN NOTICE TO THE VENDOR IF THE COMMODITIES AND/OR SERVICES SUPPLIED ARE OF AN INFERIOR QUALITY OR DO NOT CONFORM WITH THE SPECIFICATIONS OF THE BID AND CONTRACT HEREIN.</p> <p><b>OPEN MARKET CLAUSE:</b> THE DIRECTOR OF PURCHASING MAY AUTHORIZE A SPENDING UNIT TO PURCHASE ON THE OPEN MARKET, WITHOUT THE FILING OF A REQUISITION OR COST ESTIMATE, ITEMS SPECIFIED ON THIS CONTRACT FOR IMMEDIATE DELIVERY IN EMERGENCIES DUE TO UNFORESEEN CAUSES (INCLUDING BUT NOT LIMITED TO DELAYS IN TRANSPORTATION OR AN UNANTICIPATED INCREASE IN THE VOLUME OF WORK).</p> <p><b>QUANTITIES:</b> QUANTITIES LISTED IN THE REQUISITION ARE APPROXIMATIONS ONLY, BASED ON ESTIMATES SUPPLIES BY THE STATE SPENDING UNIT. IT IS UNDERSTOOD AND AGREED THAT THE CONTRACT SHALL COVER THE QUANTITIES ACTUALLY ORDERED FOR DELIVERY DURING THE TERM OF CONTRACT, WHETHER MORE OR LESS THAN THE QUANTITIES SHOWN.</p> <p><b>ORDERING PROCEDURE:</b> SPENDING UNIT(S) SHALL ISSUE A WRITTEN EQUIPMENT CONTRACT ORDER (FORM NUMBER WV-35) FOR COMMODITIES COVERED BY THIS CONTRACT. THE ORIGINAL WV-35 MUST BE SENT TO THE PURCHASING DIVISION OF THE DEPARTMENT OF ADMINISTRATION. AFTER APPROVAL AND ENCUMBRANCE, ONE COPY OF THE PURCHASE ORDER WILL BE RETURNED TO THE SPENDING UNIT AND ONE COPY FORWARDED TO THE VENDOR AS AUTHORIZATION FOR SHIPMENT. NO ORDER IS VALID UNLESS APPROVED AND ENCUMBERED BY THE PURCHASING DIVISION.</p> <p><b>BANKRUPTCY:</b> IN THE EVENT THE VENDOR/CONTRACTOR FILES FOR BANKRUPTCY PROTECTION, THE STATE MAY DEEM THE CONTRACT NULL AND VOID, AND TERMINATE SUCH CONTRACT WITHOUT FUTHER ORDER.</p>						

SIGNATURE			SEE REVERSE SIDE FOR TERMS AND CONDITIONS		TELEPHONE		DATE	
<i>Michael W. ...</i>					(724) 437-1578		6/10/11	
TITLE			FEIN		ADDRESS CHANGES TO BE NOTED ABOVE			
V. President			25-1389795					

WHEN RESPONDING TO RFO, INSERT NAME AND ADDRESS IN SPACE ABOVE LABELED 'VENDOR'





State of West Virginia  
 Department of Administration  
 Purchasing Division  
 2019 Washington Street East  
 Post Office Box 50130  
 Charleston, WV 25305-0130

# Request for Quotation

RFQ NUMBER  
**7011EC21**

PAGE  
**7**

ADDRESS CORRESPONDENCE TO ATTENTION OF  
**BUYER 33**  
**304-558-2402**

RECEIVED

**\*709015804 724-437-1578**  
**UNIONTOWN INDUSTRIAL EQUIP CO**  
**2266 UNIVERSITY DR**  
**LEMONT FURNACE PA 15478**

SHIP TO

**DIVISION OF HIGHWAYS**  
**EQUIPMENT DIVISION**  
**ROUTE 33**  
**BRUSHY FORK ROAD**  
**BUCKHANNON, WV**  
**26201 304-472-1750**

DATE PRINTED	TERMS OF SALE	SHIP VIA	F.O.B.	FREIGHT TERMS
04/04/2011				

BID OPENING DATE: **06/01/2011** BID OPENING TIME **01:30PM**

LINE	QUANTITY	UOP	CAT NO	ITEM NUMBER	UNIT PRICE	AMOUNT
SEALED BID						
BUYER:		SHERI SLONE - FILE 33				
RFQ. NO.:		7011EC21				
BID OPENING DATE:		06/01/2011				
BID OPENING TIME:		1:30 PM				
PLEASE PROVIDE A FAX NUMBER IN CASE IT IS NECESSARY TO CONTACT YOU REGARDING YOUR BID: (724) 437-2098						
-----						
CONTACT PERSON (PLEASE PRINT CLEARLY):		MICHAEL W. CLOWER				
-----						
***** THIS IS THE END OF RFQ 7011EC21 ***** TOTAL:						<u>\$71,500.00</u>

SIGNATURE <i>Michael W. Clower</i>			TELEPHONE (724) 437-1578	DATE 6/10/11
TITLE V. President	FEIN 25-1389795	ADDRESS CHANGES TO BE NOTED ABOVE		

WHEN RESPONDING TO RFQ, INSERT NAME AND ADDRESS IN SPACE ABOVE LABELED 'VENDOR'



WEST VIRGINIA DEPARTMENT OF TRANSPORTATION  
DIVISION OF HIGHWAYS  
EQUIPMENT DIVISION

PROCUREMENT SPECIFICATIONS  
NO. 352-1-D

OPEN END CONTRACT  
ALL WHEEL DRIVE LOADER WITH BACKHOE, WHEEL TYPE

1.0 PURPOSE

It is the purpose of these specifications to describe an All Wheel Drive Loader with Backhoe, Wheel Type (hereinafter referred to as a "unit") to be purchased for use by the West Virginia Division of Highways (DOH) on an Open End Contract basis.

2.0 BIDDING PROCEDURES

**The current purchasing procedures regarding bidding as established by the Department of Administration, Purchasing Division, shall apply.** Failure to submit the "Request for Quotation" forms, complete in its entirety and according to directions indicated, may subject the bidder to disqualification. **Each bid submitted shall also be accompanied by a Bidder's Evaluation Report completed in detail.** Addendums in order, along with exception sheets, should be with Bidder's Evaluation Report. **FAILURE TO SUBMIT THE BIDDER'S EVALUATION REPORT, COMPLETE IN ITS ENTIRETY, WILL RESULT IN AUTOMATIC DISQUALIFICATION.**

3.0 SPECIFICATIONS

The specifications named herein, mandatory and non-mandatory, establish the acceptable level of quality only and are not intended to reflect a preference or favor any particular brand or vendor.

3.1 EXCEPTIONS TO NON-MANDATORY SPECIFICATIONS

Exception to a non-mandatory unit specification may be made by the bidder, providing the exception is not available from the manufacturer. **Any such exception must be noted on the bidder's evaluation report and should be accompanied by supporting documentation/literature from the manufacturer. Any exception must be indicated on a separate attachment to the bidder's evaluation report and labeled as "Exception to Specifications".** The state reserves the right to waive minor irregularities in bids or specifications in accordance with §148-1-4(f) of the WV Legislative Rules and Regulations.

### 3.2 MANDATORY SPECIFICATIONS

All specifications preceded by "shall, will, and/or must" or are stated as a "minimum and/or maximum" are mandatory as stated in Purchasing Divisions Policies and Procedures. Any bid failing to meet any mandatory item shall be immediately disqualified. Failure to respond in the appropriate evaluation section will also be grounds for immediate disqualification at the discretion of the State.

The State shall review and consider any such variation or exception, and may at its sole discretion, issue an addendum to change mandatory specifications deemed to be in the State's best interest. Bids from any vendor failing to attend the mandatory pre-bid shall be disqualified. Bids containing any variation or exception to a mandatory specification that was not addressed during the previous pre-bid conference and accepted by the issuance of an Addendum shall be disqualified.

### 4.0 REPRESENTATIVE UNIT FOR TEST

The successful vendor must (if specified) provide DOH one (1) completed representative unit to be observed and evaluated on each order to insure compliance with specification. If requested, the time period for testing and evaluation shall be seven (7) working days following receipt of the unit. DOH will incur no obligation for deterioration of surfaces, finishes, seals, and mechanical or electrical parts on the unit resulting from operation and testing within the limits of these specifications; nor will DOH incur obligation for damage to the unit resulting from failure to meet specifications when due care and attention is given by DOH and testing is done within the limits of these specifications. Failure of the pilot unit to satisfactorily meet specifications as bid may be cause for cancellation of the purchase order, and return of the delivered unit along with all associated equipment to the vendor at the vendor's expense.

### 4.1 CONDITION OF UNIT(S) UPON DELIVERY

All units must arrive at the prescribed delivery point having been completely preserviced with oil, lubricants, and coolant. All prescribed precautions pertaining to first operations and break-in of the unit are to be posted conspicuously on the unit for ready observance by the operator.

### 4.2 DELIVERY

Delivery point of the completely assembled representative unit will be the DOH, Equipment Division, Route 33 at Brushy Fork Road, Buckhannon, West Virginia (26201).

The vendor is responsible for guaranteeing delivery of the completed units within the time specified and agreed to by the State. Delivery is preferred within 120 calendar days after receipt of purchase agreement. The vendor is responsible for establishing and coordinating delivery terms with allied manufacturers or suppliers. Delivery terms

should be stated in the bid and the State reserves the right to accept or reject such terms. Failure to reach an agreement may result in rejection of the bid. **The successful bidder shall provide their manufacturer's confirmation of the order to the WVDOH contact person within seven (7) working days after receiving the approved purchase order.**

**A completed pilot model for inspection must be provided within 90 calendar days after receipt of the purchase agreement by the successful vendor.**

Delivery is an integral part of this specification and failure to comply will be cause to initiate a D.O.T. Administrative Form WV-82, Vendor Performance Form. The WV-82 Form will provide a means of officially notifying the Purchasing Division and the vendor of unsatisfactory performance; such as late deliveries, poor service, inadequate parts supplies, etc.

The decision to initiate subject Form will be at the sole discretion of the D.O.H. Commissioner's established Equipment Review Board.

Issuance of the WV-82 Vendor Complaint Form on unsatisfactory delivery against any vendor will be cause to refuse to consider similar items from those vendors on future Request For Quotations.

(NOTE: Delivery time could be altered due to labor strikes, severe inclement weather conditions, etc.)

## 5.0 AWARD CRITERIA

- 5.1 DOH will recommend the award in accordance with the RFQ evaluation criteria described in the requisition. **The award shall be made to the lowest unit cost vendor that meets or exceeds the specifications.** DOH reserves the right to place multiple orders in any quantity.

## 6.0 SPECIFICATIONS AND GUIDELINES - GENERAL

### 6.1 IDENTIFICATION OF THE UNIT BEING PROPOSED

**The bidder must identify the unit by manufacturer, model, series, and year of manufacture, to enable identification by DOH in the manufacturer's specifications of the proposed unit.** The bidder will submit complete descriptive literature of the proposed unit, to establish that the bid is the manufacturer's most current model, including latest engineering improvements, which have been, or will imminently be, regularly advertised and sold on the open market. The unit specified herein and offered

to be manufactured after January 1, 2011 and be clearly identified and marked with date of manufacture.

6.2 OPERATING AND SERVICE MANUALS AND PARTS LISTS

An operator's manual must be included with each unit upon delivery. A "line sheet" (if applicable) and Equipment Preventative Maintenance Questionnaire (as shown in X6.2 of the Bidder's Evaluation Report) must be with pilot unit upon delivery. In addition, there must be 12 service, shop, or maintenance manuals; ten (10) to be distributed to the Districts and two (2) for the Equipment Division. Also, there must be 14 parts manuals; ten (10) to be distributed to the Districts and four (4) for Equipment Division use. CD ROM is preferred in lieu of parts or service manuals.

\* NOTE: MANUALS SHALL BE DELIVERED UPON COMPLETION OF DELIVERY OF TOTAL UNITS. FAILURE TO DO SO WILL DELAY PAYMENT.

6.3 TRAINING:

Manufacturers and/or dealers will be required to stage a thorough seminar on the subjects of Preventative Maintenance, Operator and Mechanic Training. **In order to keep the operators and mechanics updated, the successful vendor shall conduct training with each purchase order against this open end contract.** Training is preferred within 2 working days after delivery of the pilot unit on the individual purchase order.

**Manufacturers and/or dealers shall be required to furnish the Training Academy with one (1) Operator's Manual to be shipped direct to WVDOH Training Academy, Post Office Box 610, Buckhannon, West Virginia 26201 prior to delivery of the pilot.**

The seminar to be held at the W. Va. Division of Highways, Equipment Division, Buckhannon, West Virginia.

6.4 PREVENTIVE MAINTENANCE AND OPERATOR PROCEDURES:

**Manufacturers and/or dealers will be required to submit to the Equipment Division, in addition to the operating and service manuals, booklets and pamphlets explaining the Preventive Maintenance and Operator Procedures to be used by the operators of this equipment, and must include such things as daily prestart inspection procedure, service schedule, and routine maintenance required, safety precautions, etc.**

**The successful vendor shall furnish all training aids; i.e., videos, projectors, etc. required in conducting the training.**

## 6.5 WARRANTY AND SERVICE POLICY

The Manufacturers warranty or service policy is to apply to the unit. Such warranty or service policy is to be recognized at any authorized unit dealer, representing manufacturer of proposed unit throughout the State of West Virginia. The applicable warranty or service policy will not be contingent upon obtaining routine service, lubrication, and servicing of the unit from factory authorized agencies. It will be the responsibility of the bidder to have available labor to repair or replace any defective replacement parts, components and materials, and to have available those replacement parts, components, and/or materials found to be defective during the terms of the warranty period. The bidder should state the labor rates, locations where parts will be stocked, availability of parts, and discounts offered for parts, when terms of the warranty offer a pro-rated cost for parts and labor. In addition, the successful bidder should offer field work to repair or replace defective parts, components, and materials found to be defective during the terms of the warranty and should provide mechanic's travel rates, mileage charges, field mechanic rates, and any surcharge for miscellaneous items, if applicable, for field work during the warranty period. Submit to Division of Highways any technical or engineering improvements during the term of the warranty. **The unit must be accompanied upon delivery by the unit's manufacturer's executed warranty or service policy.**

**A mandatory minimum two (2) year bumper to bumper basic parts and labor warranty excluding abuse and normal wear items is required for this unit.**

**THE "WARRANTY AND SERVICE POLICY QUESTIONNAIRE" ATTACHED IN THE BIDDER'S EVALUATION REPORT MUST BE COMPLETED IN ITS ENTIRETY BY THE SUCCESSFUL BIDDER OR MANUFACTURER PRIOR TO DELIVERY OF THE PILOT MODEL. (SEE SECTION X6.5 OF BIDDER'S EVALUATION REPORT).**

## 6.6 EVALUATION COMMITTEE REQUIREMENTS

Detailed component specifications, product literature, component models, required for specification compliance determination by the Evaluation Committee should be provided with each bid. Any information supplied that is contrary to/or conflicting with the specifications and/or attached Bidders Evaluation Report may be sufficient cause for rejection of bid.

## 6.7 UNSPECIFIED ACCESSORIES & FEATURES

**All parts, equipment, accessories, material, design and performance characteristics not specified herein, but which are necessary to provide a complete unit, must be furnished with each unit and required to conform to strength, quality of material, and quality of workmanship to those which are advertised and provided to the market in general by the unit industry.**

**All parts and accessories advertised and regularly supplied as standard shall be included, except those which would represent duplication of these specified, and except those which, by specification, are not to be furnished. All standard safety features, required by Federal and State Law, shall be included.**

SPECIFICATIONS OF THE QUOTED UNIT ARE AS FOLLOWS:

- 7.0 Unit to be of Manufacturers AWD design and **shall provide engage and disengage selection accessible from operators station.**
- 7.1 Engine:
  - 7.1.1 Diesel fueled, water cooled.
  - 7.1.2 **Number of cylinders: minimum four (4).**
  - 7.1.3 **SAE Net Horsepower: 75 minimum.**
- 7.2 Transmission:
  - 7.2.1 **Transmission speeds to be four (4) forward fully synchronized; four (4) reverse minimum.**
  - 7.2.2 **Minimum top travel speed to 20 MPH.**
  - 7.2.3 Foot operated automatic release, rear axle differential lock engageable under full engine RPM required.
- 7.3 Steering:
  - 7.3.1 Full power steering with emergency dead engine steering capability.

#### 7.4 Brakes:

- 7.4.1 **Service brakes to be 2-wheel minimum**, wet disk type, sealed and fully enclosed to allow operating in water, mud, snow, and other adverse conditions without encountering brake loss or fade.
- 7.4.2 Service brakes to be pressure lubricated and cooled.
- 7.4.3. Service brakes to be self adjusting type.
- 7.4.4 Service brakes to be self equalizing.
- 7.4.5 The parking/secondary brake system to be independent of service brakes and of sufficient design to hold weight of machine on incline.
- 7.4.6 The parking brake system to be equipped with a warning light and/or audible alarm.
- 7.4.7 **All brakes shall conform to or exceed Federal and State standards.**

#### 7.5 Hydraulic System:

- 7.5.1 The hydraulic system to be the manufacturers standard. The system should incorporate a suction strainer and a replaceable return line filter.
- 7.5.2 **The system should provide a minimum flow of 34 GPM at approximately 2200 RPM to the backhoe and adequate cooling for hydraulic tools and attachments.**
- 7.5.3 Backhoe stabilizer hydraulic lock-outs should be provided in both the working and transport positions.
- 7.5.4 Auxiliary valve, with foot pedal control for efficient operation of motor driven attachments and machine mounted rock breakers.

#### 7.6 Electrical System:

- 7.6.1 Manufacturers standard 12 volt electrical system.
- 7.6.2 Alternator approximately 78 AMPS.
- 7.6.3 Batteries to be maintenance free type and provide a cold crank amps of 1150 each at zero degrees.

7.7 Cooling System:

7.7.1 **The cooling system shall be capable of maintaining engine temperature within the manufacturers recommended range during continuous operation.**

7.7.2 The coolant system to incorporate a thermostat and by-pass for warm up.

7.7.3 The system to be filled with permanent extended life anti-freeze **solution rated to a minus 30 degrees F minimum.**

7.8 Operators Station:

7.8.1 Cab to be fully enclosed SAE ROPS/FOPS certified.

7.8.2 Cab to be isolation mounted.

7.8.3 Instrumentation vandal protection to be included on complete unit.

7.8.4 Air ride seat should be deluxe cushioned, swing around type operators seat. Fully adjustable, damped and to include manufacturer's seat belt with retractor feature.

7.8.5 **Tinted safety glass shall be provided at all locations.**

7.8.6 **Cab doors shall be lockable and keyed alike.**

7.8.7 Unit should provide front and rear windshield wipers with washers.

7.8.8 Manufacturers heaviest duty heater/defroster to be provided.

7.8.9 Unit to be equipped with manufacturer air conditioning.

7.9 Instruments: Unit to have lighted gauges and/or monitoring system to include:

7.9.1 Transmission temperature.

7.9.2 Engine coolant temperature.

7.9.3 Engine oil pressure.

7.9.4 Hydraulic filter restriction.

7.9.5 Air cleaner restriction.

7.9.6 Fuel gauge.



- 7.9.7 Volt/Amp gauge.
- 7.9.8 Hour meter (to be engine controlled, not key switch).
- 7.9.9 Engine coolant temperature and engine oil pressure and parking brake system to include audible or visual warning systems.
- 7.10 Accessories:
  - 7.10.1 Locking type toolbox to be large enough to store standard size hand operated grease gun and any special tools required by manufacturer.
  - 7.10.2 OSHA approved back up alarm.
  - 7.10.3 Horn.
  - 7.10.4 Hand and foot controlled throttle.
  - 7.10.5 Muffler with rain proof exhaust.
  - 7.10.6 Lockable engine service door and keyed same as cab door/s.
  - 7.10.7 SMV emblem.
  - 7.10.8 Non slip type mounting steps and safety handholds.
  - 7.10.9 Backhoe boom transport locks.
  - 7.10.10 One (1) complete set of filter elements for unit to be provided.
  - 7.10.11 Unit to have Class 1 LED low profile beacon
  - 7.10.12 Unit to have left and right side and inside rear view mirrors.
- 7.11 Lighting:
  - 7.11.1 **Unit to have a minimum of two (2) front halogen work/driving lights switched and identified at operator's station.**
  - 7.11.2 Two combination stop/tail lights.
  - 7.11.3 Two (2) rear halogen work lights to be switched and identified at operator station.
  - 7.11.4 Two (2) front and two (2) rear turn and flashing lights.

7.11.5 Cab dome light.

7.12 Tires:

7.12.1 Tires to be manufacturers standard for model bid.

7.13 Vehicle Frame:

7.13.1 Unit to feature a single piece weldment, full length unitized main frame.

7.14 Loader:

7.14.1 Loader to be self-leveling.

7.14.2 Unit to be equipped with automatic return-to-dig feature.

7.14.3 Unit to provide a G.P. bucket rated at approximately 1.3. C.Y. SAE heaped capacity and a width of approximately 92 inches with bolt on cutting.

7.14.4 Breakout force of approximately 9,500 pounds.

7.14.5 Loader lift rating of approximately 6,500 pounds to full height required.

7.14.6 Dumping clearance at full height and 40 degrees, 103 inches approximately.

7.14.7 Bucket rollback at ground approximately 40 degrees.

7.15 Backhoe:

7.15.1 Unit should have an approximate digging depth of a least 15 feet 4 inches.

7.15.2 Backhoe lifting capacity of approximately 3,500 pounds to 12 foot lift height through the full 180 degrees swing arc.

7.15.3 Backhoe bucket cylinder digging force of 11,500 pound approximately.

7.15.4 Bucket to be manufacturers standard 24 inches with hardened/replaceable teeth.

7.15.5 Bucket rotation 180 degrees.

7.15.6 Provisions to be made for quick-coupling hydraulic tools, (i.e. road breakers, jack hammers, etc.) to the unit hydraulic system.

- 7.15.7 Unit to be capable of operating backhoe and hydraulic tools simultaneously.
- 7.15.8 **Unit shall be equipped with extend-a-hoe feature with approximate dig depth of 19 feet.**
- 7.16 Operating Weight:
- 7.16.1 SAE operating weight of 16,000 pounds (approximately) exclusive of tire ballast and/or counterweights.
- 7.17 Paint:
- 7.17.1 The loader is to be painted manufacturers standard.
- 7.18 **All units shall be delivered to WVDOH with all manufacturers recommended safety related decals and safety features intact.**
- 7.19 **Vendor must certify that unit offered will meet or exceed the "Occupational Safety and Health Act of 1970" or subsequent changes that are in effect at time of manufacture of the unit.**
- 7.20 **Advertising: Only one (1) manufacturer name plate, which must include model number, may appear on exterior of unit.** Logos created through the stamping or casting process of manufacturer are also acceptable. No logo will interfere with the Department's striping and logo.

WEST VIRGINIA DEPARTMENT OF TRANSPORTATION  
 DIVISION OF HIGHWAYS  
 EQUIPMENT DIVISION

BIDDER'S EVALUATION REPORT

PROCUREMENT SPECIFICATIONS FOR OPEN END CONTRACT  
 NO. 352-1-D

ALL WHEEL DRIVE LOADER WITH BACKHOE, WHEEL TYPE

NOTE TO BIDDER: Procurement Specification No. 352-1-D, Paragraph 2.0 recommends the completion and submittal of this Report with your bid. Purpose of this Report is to enable the West Virginia Division of Highways Evaluation Committee to make full and fair evaluation of the bid. Addendums in order, along with a summary of exception as a separate attachment, should be with Bidder's Evaluation Report. FAILURE TO SUBMIT THIS REPORT, COMPLETE IN ITS ENTIRETY, MAY SUBJECT THE BIDDER TO DISQUALIFICATION.

Reference Requisition No.: 7011EC21

Bidder's Name: Uniontown Industrial Equipment Co. Inc.

Address: 2266 University Drive, Lemont Furnace PA 15456

Telephone Number: (724) 437-1578

Years Bidder has been registered to do business with the State of West Virginia: 13 YRS.

Years Company has been an authorized dealer for proposed unit: 9 YRS.

X3.2 Have you complied with all mandatory specifications?  YES  NO

X4.2 DELIVERY:

X4.2.1 Delivery date of completed representative unit: 90 Calendar Days After  
 Receipt of Purchase Agreement

X4.2.2 Delivery date of balance of completed units: 120 Calendar Days After Receipt of  
 Purchase Agreement

NOTE: Vendor should type Bidder's Evaluation Report

The "Bidder's Evaluation Report" is available for download on Purchasing's Web site at  
[www.state.wv.us/admin/purchase](http://www.state.wv.us/admin/purchase)

**X5.0 - AWARD CRITERIA;****X5.1 Price per unit:**\$71,500.00 per unit**X6.0 SPECIFICATIONS - GENERAL****X6.1 Manufacturer, model, series, and date of manufacture of proposed unit:**

TEREX TLB840 2011 or current year

Is descriptive literature, fully describing proposed unit attached to your bid?  YES  NO

If not, why? \_\_\_\_\_

**X6.2 Will the required number of service manuals, and complete parts list be delivered to the Equipment Division at Buckhannon upon completion of delivery of total units?** YES  NO**Will the required Equipment Preventive Maintenance Form (Section X6.2 of Bidders Evaluation Report) be provided upon inspection of the pilot unit?** YES  NO

X6.2  
2-10-00

EQUIPMENT PREVENTATIVE MAINTENANCE QUESTIONNAIRE

THIS FORM MUST BE COMPLETED IN ITS ENTIRETY BY SUCCESSFUL BIDDER OR MANUFACTURER'S TECHNICAL REPRESENTATIVE PRIOR TO DELIVERY OF PILOT MODEL TO THE WVDOT.

DESCRIPTION: \_\_\_\_\_ MAKE: \_\_\_\_\_

MODEL: \_\_\_\_\_ YEAR: \_\_\_\_\_ PURCHASE AMOUNT: \_\_\_\_\_

ENGINE: MAKE: \_\_\_\_\_ MODEL: \_\_\_\_\_ FUEL TYPE: \_\_\_\_\_

HORSEPOWER: \_\_\_\_\_ CYLINDER: \_\_\_\_\_ ENGINE SERIAL: \_\_\_\_\_

COOLING SYSTEM CAPACITY: \_\_\_\_\_

BELTS: DESCRIPTION: \_\_\_\_\_ PART NUMBERS: \_\_\_\_\_

\_\_\_\_\_

\_\_\_\_\_

GVW: \_\_\_\_\_ AXLE CAPACITY:FRONT: \_\_\_\_\_ REAR: \_\_\_\_\_

TIRES: FRONT MAKE & SIZE: \_\_\_\_\_

REAR MAKE & SIZE: \_\_\_\_\_

DIMENSIONS OF UNIT: LENGTH: \_\_\_\_\_ WIDTH: \_\_\_\_\_ LENGTH: \_\_\_\_\_

VENDOR CONTACT PERSON: \_\_\_\_\_ PHONE: \_\_\_\_\_

PARTS:

BATTERY MAKE: \_\_\_\_\_ MODEL: \_\_\_\_\_ CCA: \_\_\_\_\_

TOP OR SIDE POST: \_\_\_\_\_ DIMENSIONS: LENGTH \_\_\_\_\_ WIDTH \_\_\_\_\_ HEIGHT \_\_\_\_\_

SPARK PLUGS OR FUEL INJECTORS MAKE: \_\_\_\_\_ PART # \_\_\_\_\_

FUEL PUMP OR INJECTION PUMP MAKE: \_\_\_\_\_ MODEL: \_\_\_\_\_

ALTERNATOR MAKE: \_\_\_\_\_ PART #: \_\_\_\_\_

STARTER MAKE: \_\_\_\_\_ PART #: \_\_\_\_\_

TURBO CHARGER MAKE: \_\_\_\_\_ PART #: \_\_\_\_\_

TRANS. MAKE: \_\_\_\_\_ MODEL: \_\_\_\_\_ AUTO/MANUAL: \_\_\_\_\_

HYDRAULIC PUMP MAKE: \_\_\_\_\_ MODEL: \_\_\_\_\_

FILTERS MAKE PART NO. LUBRICANT MANUFACTURER TYPE

OIL _____	ENGINE _____
AIR INNER _____	TRANSMISSION _____
AIR OUTER _____	POWER STEERING _____
FUEL PRIMARY _____	HYDRAULIC _____
FUEL SECONDARY _____	DIFFERENTIALS _____
COOLANT _____	BRAKE FLUID _____
HYDRAULIC _____	COOLANT _____
OTHER _____	OTHER _____

## X6.3 TRAINING:

Will training seminar be conducted on Preventive Maintenance, Operator and Mechanic Training  
 YES  NO

Will you conduct training with each purchase order against this open end contract?  
 YES  NO

Will training be conducted within 2 working days from the delivery of the pilot unit on the individual purchase order?  
 YES  NO

If NO, explain time frame 2 weeks

Will an Operator's Manual be furnished directly to Training Academy prior to the delivery of the pilot?  
 YES  NO

X6.4 If you are the successful vendor, will you furnish all training aids, i.e., videos, projectors, required in conducting the training?  
 YES  NO

X6.4.1 Will all manuals, booklets, etc. explaining preventive maintenance, operator procedures, and service schedule be delivered with each unit?  
 YES  NO  
 If NO, explain \_\_\_\_\_

## X6.5 WARRANTY AND SERVICE POLICY

Will the warranty and service you provide comply with all areas as stated in Section 6.5 of specifications  
 YES  NO

Is warranty literature attached?  
 YES  NO

Is a minimum two (2) year bumper to bumper basic parts and labor warranty excluding abuse and normal wear items included?  
 YES  NO

Describe:  
 \_\_\_\_\_  
 \_\_\_\_\_

## X6.5 WARRANTY AND SERVICE POLICY QUESTIONNAIRE

**THIS FORM MUST BE COMPLETED IN ITS ENTIRETY AND SUBMITTED WITH YOUR BID.**  
(If additional lines are needed, make copies of form.)

1. Define the terms of the standard warranty. If not offered, so state. (Attach copy)

2 year or 2,000 hrs. bumper to bumper, whichever occurs first

2. Define warranty service to be performed at DOH facilities and warranty service to be performed at manufacturer's representative facility. List name and location of manufacturer's representative.

When warranty service is preformed at DHO facilities DOH is responsible for travel & mileage to and from their facility. When warranty service is performed at UIEC DOH is responsible for round trip transportation.

3. List locations for parts inventories that are within the State of West Virginia. Also, list availability levels, if known.

Terex has parts locations in WV, PA, OH & VA. Terex machines are supported by Southaven, MISS parts facility.

4. During the term of warranty, list the guarantee discount to manufacturer's published list price for parts that bidder will sell the parts to owner.

A.	Terms: Net 30	Manufacturer's published list price less: <u>0</u> % discount
B.	Terms: Net 60	Manufacturer's published list price less: <u>0</u> % discount
C.	Terms: Net 90	Manufacturer's published list price less: <u>0</u> % discount

5. During the term of warranty, will all manufacturers or engineering improvements be submitted to Division of Highways? X YES      NO

6. During the term of warranty, list the guaranteed rates charged for repair to the unit.

A. Shop Rate \$ 75.00 per mechanic hour

B. Travel Time Charge \$ 75.00 per mechanic hour  
(Specify if one-way) N/A; port to port N/A

C. Mileage Charge \$ 2.00 per vehicle mile  
(Specify if one-way) N/A; port to port N/A

D. Field Mechanic Rate \$ 75.00 per mechanic hour

E. Specify period of time that prices are in effect: 1 year

F. Surcharge for miscellaneous items: 0 %



## X6.6 EVALUATION COMMITTEE REQUIREMENTS

Is all component specifications, product literature, component models provided for Evaluation Committee bid determination?  YES  NO

**X6.7 Will all parts, equipment, accessories, material, design and performance characteristics not specified herein, but which are necessary to provide a complete unit, be furnished with the unit and conform in strength, quality of material, and quality of workmanship to those which are advertised and provided to the market in general by the unit industry?**

YES  NO

**X6.7.1 Are all parts and accessories adequate and regularly supplied as standard to be included except those which may be duplications of specifications herein, and except these by specification are not to be furnished?**

YES  NO

**X6.7.2 Are all standard safety features that are required by Federal and State statutes of law included?**

YES  NO

## SPECIFICATIONS OF THE QUOTED UNIT:

The bidder should complete the following schedule in order for the Division to compare the actual bid unit to the specifications. Should the bidder except a requirement, then such exception may be only on the basis that such feature is not offered by the manufacturer. **The Division will have the sole discretion as to whether the bidder's substitution meets the requirements of the specification.**

Manufacturer: Terex Model: TLB840

**X7.0 Manufacturers AWD design with engage/disengage selection accessible operators station?**

YES  NO

**X7.1 Engine:**

**X7.1.1 Diesel fueled, water cooled?**

YES  NO

**X7.1.2 Number of Cylinders:** 4

**X7.1.3 SAE Net Horsepower:** 88.1

**X7.2 Transmission:**

**X7.2.1 Are there 4 forward fully synchronized speeds/ 4 reverse?**

YES  NO

**X7.2.2 Minimum top travel speed:** 25.1 MPH

**X7.2.3 Foot operated automatic release, rear axle differential lock engageable under full engine RPM?**

YES  NO

- X7.3 Steering:
- X7.3.1 Does unit provide full power steering w/emergency dead engine steering capability?  YES  NO
- X7.4 Brakes:
- X7.4.1 Are the service brakes 2 wheel minimum, wet disk type, sealed/fully enclosed to allow operation in water, mud, snow,/other adverse conditions without encountering brake loss or fade?  YES  NO
- X7.4.2 Are the service brakes pressure lubricated and cooled?  YES  NO
- X7.4.3 Are the service brakes self adjusting type?  YES  NO
- X7.4.4 Are the service brakes self equalizing?  YES  NO
- X7.4.5 Is the parking/secondary brake system independent of the service brakes/of sufficient design to hold weight of machine on incline?  YES  NO
- X7.4.6 Is the parking brake system equipped w/warning light/or audible alarm?  YES  NO
- X7.4.7 Do the brakes conform to or exceed Federal/State standards?  YES  NO
- X7.5 Hydraulic System:
- X7.5.1 Is the system provided the manufacturers standard for the model bid/ incorporate a suction strainer/replaceable return line filter?  YES  NO
- X7.5.2 Does the backhoe offered provide adequate cooling for hydraulic tools/attachments?  YES  NO  
Specify GPM 37.50 at 2200 R.P.M.
- X7.5.3 Are backhoe stabilizer hydraulic lock-outs provided in both the working/transport positions?  YES  NO
- X7.5.4 Is foot pedal control provided for efficient operation of motor driven attachments/boom mounted rock breaker?  YES  NO
- X7.6 Electrical System:
- X7.6.1 Manufacturer's 12 volt electrical system provided?  YES  NO
- X7.6.2 Specify alternator capacity? 100 amp
- X7.6.3 Are batteries maintenance free type?  YES  NO  
CCA: 830 CCA

## X7.7 Cooling System:

X7.7.1 **Capable of maintaining engine temperature within the manufacturers recommended range during continuous operation?**  YES  NO

X7.7.2 Coolant system incorporate a thermostat/by-pass for warm up?  YES  NO

X7.7.3 Is the system filled w/permanent anti-freeze solution rated to a minus 30°F or lower?  YES  NO

## X7.8 Operators Station:

X7.8.1 Is the cab fully enclosed SAE ROPS/FOPS certified?  YES  NO

X7.8.2 Is the cab isolation mounted?  YES  NO

X7.8.3 Is instrumentation vandalism protection included on complete unit?  YES  NO

X7.8.4 Is the air ride seat deluxe cushioned, swing around type operators seat, fully adjustable, damped, And include manufacturers seat belt w/retractor feature?  YES  NO

X7.8.5 **Is tinted safety glass provided in all locations?**  YES  NO

X7.8.6 **Are the cab doors lockable/keyed alike?**  YES  NO

X7.8.7 Are front/rear windshield wipers w/washers provided?  YES  NO

X7.8.8 Is the heater/defroster manufacturers heaviest duty?  YES  NO

X7.8.9 Is unit equipped with manufacturers air conditioning?  YES  NO

## X7.9 Instruments: Unit to have lighted gauges/or monitoring system to include:

X7.9.1 Transmission temperature?  YES  NO

X7.9.2 Engine coolant temperature?  YES  NO

X7.9.3 Engine oil pressure?  YES  NO

X7.9.4 Hydraulic filter restriction?  YES  NO

X7.9.5 Air cleaner restriction?  YES  NO

X7.9.6 Fuel gauge?  YES  NO

X7.9.7 Volt/Amp gauge?  YES  NO

- X7.9.8 Hour meter (engine controlled, not key switch)?  YES  NO
- X7.9.9 Engine coolant temperature, engine oil pressure, parking brake system with audible or visual warning systems?  YES  NO
- X7.10 Accessories:
- X7.10.1 Locking type tool box large enough to store standard size hand operated grease gun/any special tools required by manufacturer?  YES  NO
- X7.10.2 OSHA approved back up alarm?  YES  NO
- X7.10.3 Horn?  YES  NO
- X7.10.4 Hand/foot controlled throttle?  YES  NO
- X7.10.5 Muffler with rain proof exhaust?  YES  NO
- X7.10.6 Lockable engine service door/keyed same as cab door/s?  YES  NO
- X7.10.7 SMV emblem  YES  NO
- X7.10.8 Non slip type mounting steps/safety hand holds?  YES  NO
- X7.10.9 Backhoe boom transport locks?  YES  NO
- X7.10.10 Is one (1) complete set of filter elements for unit?  YES  NO
- X7.10.11 Does unit have Class 1 LED low profile beacon?  YES  NO
- X7.10.11.1 Is provided strobe light in accordance w/radio interference specifications not generating more than 1.0 UV of interference on a radio receiver w/12db of quieting?  YES  NO
- X7.10.12 Are left/right side and inside rear view mirrors provided?  YES  NO
- X7.11 Lighting:
- X7.11.1 Number of front halogen work/driving lights: 4
- X7.11.1.1 Switched/identified at operator's station?  YES  NO
- X7.11.2 Number of combination stop/tail lights: 2
- X7.11.3 Number of rear halogen work lights switched/identified at operator stations: 2
- X7.11.4 Number of front/rear turn/flashing lights: 2
- X7.11.5 Does the cab have a dome light?  YES  NO

- X7.12 Tires:  
 X7.12.1 Front tires: 12.5/80 X 18  
 Rear tires: 19.5 L X 24
- X7.13 Vehicle Frame:  
 X7.13.1 Does the unit have a single piece weldment, full length unitized main frame?  YES  NO
- X7.14 Loader:  
 X7.14.1 Is the loader self leveling?  YES  NO  
 X7.14.2 Is the unit equipped with automatic return-to-dig feature?  YES  NO  
 X7.14.3 General purpose bucket size 1.32 C.Y. heaped capacity with bolt on cutting edge  
 YES  NO
- X7.14.3.1 Bucket width: 96 inches  
 X7.14.4 Breakout force: 10,485 lbs.  
 X7.14.5 Loader lift rating 7291 lbs to full height.  
 X7.14.6 Dumping clearance at full height and 40° 45  
 X7.14.7 Bucket rollback at ground 50 degrees
- X7.15 Backhoe:  
 X7.15.1 Unit digging depth: 14.9  
 X7.15.2 Backhoe lifting capacity 1706 lbs to 11.17 lift height through the full 180° (RETRACTED) swing arc.  
 X7.15.3 Backhoe bucket cylinder digging force 13,500 lbs. (RETRACTED)  
 X7.15.4 Bucket size: 24" w/hardened/replaceable teeth?  YES  NO  
 X7.15.5 Bucket rotation 196 degrees. (EXTENDED)  
 X7.15.6 Are provisions made for quick-coupling hyd tools to the unit hyd system?  YES  NO  
 X7.15.7 Is the unit capable of operating backhoe/hyd tools simultaneously?  YES  NO  
 X7.15.8 Is the unit equipped with extend-a-hoe feature/approx. 19' dig depth?  YES  NO

X7.16 Operating Weight:

X7.16.1 SAE operating weight 15,895 lbs exclusive of tire ballast/or counterweights.

X7.16.2 List all other features considered as standard equipment but not specifically addressed:

---

---

X7.17 Paint:

Will loader be painted manufacturers standard color?  YES  NO

X7.18 Will all units be delivered to WVDOH with all manufacturers recommended safety related decals/safety features intact?  YES  NO

X7.19 Does the proposed unit meet or exceed the "OSHA of 1970" and/or subsequent changes?  YES  NO

X7.20 Does the unit conform to the advertising guidelines?  YES  NO



State of West Virginia  
 Department of Administration  
 Purchasing Division  
 2019 Washington Street East  
 Post Office Box 50130  
 Charleston, WV 25305-0130

# Request for Quotation

RFQ NUMBER
7011EC21

PAGE
1

ADDRESS CORRESPONDENCE TO ATTENTION OF
BUYER 33 304-558-2402

VENDOR

\*709015804      724-437-1578  
 UNIONTOWN INDUSTRIAL EQUIP CO  
 2266 UNIVERSITY DR  
  
 LEMONT FURNACE PA 15478

SHIP TO

DIVISION OF HIGHWAYS  
 EQUIPMENT DIVISION  
 ROUTE 33  
 BRUSHY FORK ROAD  
 BUCKHANNON, WV  
 26201      304-472-1750

DATE PRINTED	TERMS OF SALE	SHIP VIA	F.O.B.	FREIGHT TERMS
06/01/2011				

BID OPENING DATE: 06/15/2011      BID OPENING TIME 01:30PM

LINE	QUANTITY	UOP	CAT. NO.	ITEM NUMBER	UNIT PRICE	AMOUNT
ADDENDUM NO. 1						
BID OPENING DATE AND TIME CHANGED						
FROM: 06/01/11 @1:30 P.M						
TO: 06/15/11 @1:30 P.M.						
NO OTHER CHANGES						
0001	1	EA		975-66	\$71,500.00	\$71,500.00
ALL WHEEL DRIVE LOADER WITH BACKHOE						
***** THIS IS THE END OF RFQ 7011EC21 ***** TOTAL:						\$71,500.00

SEE REVERSE SIDE FOR TERMS AND CONDITIONS		
SIGNATURE <i>Michael W. ...</i>	TELEPHONE (724) 437-1578	DATE 6/10/11
TITLE V. President	FEIN 25-13897956	ADDRESS CHANGES TO BE NOTED ABOVE

WHEN RESPONDING TO RFQ, INSERT NAME AND ADDRESS IN SPACE ABOVE LABELED 'VENDOR'

PRE-BID CONFERENCE  
SIGN IN SHEET

Request for Quotation Number:

7011EC21

Date:

5/17/2011 10:00

Project Description:

All Wheel Drive Loader with Backhoe, Wheel Type

PLEASE PRINT LEGIBLY. THIS INFORMATION IS ESSENTIAL TO CONTACT THE ATTENDEES IN A TIMELY MANNER. FAILURE TO DO SO MAY RESULT IN DELAYS IN YOUR COMPANY GETTING IMPORTANT BID INFORMATION.

Firm Name:	<u>MH <del>SO</del> EQUIPMENT ICB</u>
Firm Address:	<u>126 LAKEVIEW DRIVE</u> <u>CHARLESTON WV 25313</u>
Representative Attending:	<u>DES JARVIS</u>
Phone Number:	<u>304-741-8575</u>
Fax Number:	
Email Address:	<u>des.jarvis@icb.com</u>

Firm Name:	<u>C.I. WALKER MACHINERY</u>
Firm Address:	<u>P.O. Box 2427</u> <u>CHARLESTON, WV 25329</u>
Representative Attending:	<u>MATT CONNER</u>
Phone Number:	<u>(304) 543-5406</u>
Fax Number:	<u>(304) 759-6404</u>
Email Address:	<u>mconner@walker-cat.com</u>

Firm Name:	<u>UNIONTOWNS INC. (A) (C) INC.</u>
Firm Address:	<u>2266 UNIVERSITY DRIVE</u> <u>LEMONT FURNACE PA 15456</u>
Representative Attending:	<u>MIKE CLOWER</u>
Phone Number:	<u>724-437-1578</u>
Fax Number:	<u>724-437-2098</u>
Email Address:	<u>mcloster@unec.com</u>

Firm Name:	<u>Angie Moorman</u>
Firm Address:	<u>DOH</u>
Representative Attending:	
Phone Number:	
Fax Number:	
Email Address:	

Firm Name:	<u>WEST VIRGINIA TRACTOR</u>
Firm Address:	<u>P.O. Box 473</u> <u>CHARLESTON, WV 25322</u>
Representative Attending:	<u>GARY W. GRADY</u>
Phone Number:	<u>304-346-5301</u>
Fax Number:	<u>304-346-5305</u>
Email Address:	<u>wvtractor@msa.com</u>

Firm Name:	<u>WVDOIT</u>
Firm Address:	
Representative Attending:	<u>Karen Cochran</u>
Phone Number:	
Fax Number:	
Email Address:	



PRE-BID CONFERENCE  
SIGN IN SHEET

Request for Quotation Number:

7011EC21

Date:

5/17/2011 10:00

Project Description:

All Wheel Drive Loader with Backhoe, Wheel Type

PLEASE PRINT LEGIBLY. THIS INFORMATION IS ESSENTIAL TO CONTACT THE ATTENDEES IN A TIMELY MANNER. FAILURE TO DO SO MAY RESULT IN DELAYS IN YOUR COMPANY GETTING IMPORTANT BID INFORMATION.

Firm Name:	WV DOT - 0070
Firm Address:	
Representative Attending:	Debra Ferrell
Phone Number:	
Fax Number:	
Email Address:	

Firm Name:	STATE EQUIPMENT INC
Firm Address:	PO Box 3939 CHARLESTON WVA
Representative Attending:	RANDY BELCASTRO
Phone Number:	304 592 0491
Fax Number:	304 592 0499
Email Address:	RANDY B @ STATE EQUIPMENT.COM

Firm Name:	WV DOT - 0070
Firm Address:	
Representative Attending:	Tammy Clewinger
Phone Number:	
Fax Number:	
Email Address:	

Firm Name:	RISH EQUIPMENT COMPANY
Firm Address:	P.O. Box 906 BRIDGEPORT, WV 26330
Representative Attending:	ANTONIO B. SELARAO
Phone Number:	304 - 842 - 3511
Fax Number:	304 - 842 - 6626
Email Address:	aselario@rish.com

Firm Name:	Leslie Equipment Company
Firm Address:	P.O. Box 299 Norbn, WV 26285
Representative Attending:	David Gaasend
Phone Number:	(C) 304-672-9826 (W) 304-636-6121
Fax Number:	304-636-3516
Email Address:	Gaasenddavid@LEL1.Com

Firm Name:	WVDA
Firm Address:	
Representative Attending:	Kerrin Riley
Phone Number:	
Fax Number:	
Email Address:	



State of West Virginia  
 Department of Administration  
 Purchasing Division  
 2019 Washington Street East  
 Post Office Box 50130  
 Charleston, WV 25305-0130

# Request for Quotation

RFQ NUMBER
7011EC21

PAGE
1

ADDRESS CORRESPONDENCE TO ATTENTION OF:
BUYER 33 304-558-2402

VENDOR

\*709015804      724-437-1578  
 UNIONTOWN INDUSTRIAL EQUIP CO  
 2266 UNIVERSITY DR  
 LEMONT FURNACE PA 15478

SHIP TO

DIVISION OF HIGHWAYS  
 EQUIPMENT DIVISION  
 ROUTE 33  
 BRUSHY FORK ROAD  
 BUCKHANNON, WV  
 26201      304-472-1750

DATE PRINTED	TERMS OF SALE	SHIP VIA	F.O.B	FREIGHT TERMS
06/13/2011				

BID OPENING DATE: 06/29/2011      BID OPENING TIME 01:30PM

LINE	QUANTITY	UOP	CAT NO	ITEM NUMBER	UNIT PRICE	AMOUNT
ADDENDUM NO. 2						
BID OPENING DATE AND TIME CHANGED						
FROM: 06/15/2011 @1:30 P.M.						
TO: 06/29/2011 @1:30 P.M.						
NO OTHER CHANGES						
0001	1	EA		975-66	\$71,500.00	\$71,500.00
ALL WHEEL DRIVE LOADER WITH BACKHOE						
***** THIS IS THE END OF RFQ 7011EC21 ***** TOTAL:						\$71,500.00

RECEIVED  
 2011 JUN 28 AM 10:04  
 WV DEPARTMENT OF ADMINISTRATION  
 PURCHASING DIVISION

SEE REVERSE SIDE FOR TERMS AND CONDITIONS		
SIGNATURE <i>Michael W. [Signature]</i>	TELEPHONE (724) 437-1578	DATE 6/27/11
TITLE V. PRESIDENT	FEIN 25-1389795	ADDRESS CHANGES TO BE NOTED ABOVE

WHEN RESPONDING TO RFQ, INSERT NAME AND ADDRESS IN SPACE ABOVE LABELED 'VENDOR'



State of West Virginia  
 Department of Administration  
 Purchasing Division  
 2019 Washington Street East  
 Post Office Box 50130  
 Charleston, WV 25305-0130

# Request for Quotation

RFQ NUMBER
7011EC21

PAGE
1

ADDRESS CORRESPONDENCE TO ATTENTION OF
BUYER 33 304-558-2402

VENDOR

\*709015804 724-437-1578  
 UNIONTOWN INDUSTRIAL EQUIP CO  
 2266 UNIVERSITY DR  
 LEMONT FURNACE PA 15478

SHIP TO

DIVISION OF HIGHWAYS  
 EQUIPMENT DIVISION  
 ROUTE 33  
 BRUSHY FORK ROAD  
 BUCKHANNON, WV  
 26201 304-472-1750

DATE PRINTED	TERMS OF SALE	SHIP VIA	F.O.B.	FREIGHT TERMS
06/17/2011				

BID OPENING DATE: 06/29/2011 BID OPENING TIME 01:30PM

LINE	QUANTITY	UOP	CAT NO	ITEM NUMBER	UNIT PRICE	AMOUNT
ADDENDUM NO. 3						
CHANGES TO THE SPECIFICATIONS PER THE ATTACHED.						
BID OPENING DATE AND TIME REMAINS 06/29/11 @1:30 P.M.						
NO OTHER CHANGES						
0001	1	EA		975-66	\$71,500.00	\$71,500.00
ALL WHEEL DRIVE LOADER WITH BACKHOE						
***** THIS IS THE END OF RFQ 7011EC21 ***** TOTAL:						\$71,500.00

SEE REVERSE SIDE FOR TERMS AND CONDITIONS		
SIGNATURE <i>Michael W. ...</i>	TELEPHONE (724) 437-1578	DATE 6/27/11
TITLE V. PRESIDENT	FEIN 25-1389795	ADDRESS CHANGES TO BE NOTED ABOVE

WHEN RESPONDING TO RFQ, INSERT NAME AND ADDRESS IN SPACE ABOVE LABELED 'VENDOR'

ADDENDUM #3  
(ADDENDUM FROM PREBID MEETING)  
7011EC21

ALL WHEEL DRIVE LOADER WITH BACKHOE

CHANGES TO SPECIFICATIONS:

FROM:

4.2 DELIVERY – 2<sup>nd</sup> Paragraph 2<sup>nd</sup> Sentence  
Delivery is preferred within 120 calendar days after receipt of purchase agreement.

TO:

4.2 DELIVERY – 2<sup>nd</sup> Paragraph 2<sup>nd</sup> Sentence  
Delivery is preferred within 150 calendar days after receipt of purchase agreement.

FROM:

4.2 DELIVERY - 3<sup>rd</sup> Paragraph  
**A completed pilot model for inspection must be provided within 90 calendar days after receipt of the purchase agreement by the successful vendor.**

TO:

4.2 DELIVERY - 3<sup>rd</sup> Paragraph  
**A completed pilot model for inspection must be provided within 120 calendar days after receipt of the purchase agreement by the successful vendor.**

FROM:

**7.15.8 Unit shall be equipped with extend-a-hoe feature with approximate dig depth of 19 feet.**

TO:

**7.15.8 Unit shall be equipped with extend-a-hoe feature with 17 feet dig depth minimum.**

ADDENDUM #3  
(ADDENDUM FROM PREBID MEETING)  
7011EC21

ALL WHEEL DRIVE LOADER WITH BACKHOE

CHANGES TO BIDDER'S EVALUATION REPORT:

NO CHANGE REQUIRED ON BID OPENING DATE:

NO CHANGE REQUIRED

X4.2 DELIVERY

X4.2.1 Delivery date of completed representative unit: \_\_\_\_\_ Calendar Days After  
Receipt of Purchase Agreement

X4.2 Delivery date of balance of completed units: 90 Calendar Days After Receipt of  
Purchase Agreement

FROM:

X7.15.8 Is the unit equipped with extend-a-hoe feature/approx. 19' dig depth? \_YES\_NO

TO:

X7.15.8 Is unit equipped with extend-a-hoe feature  X  YES   NO

Extend-a-hoe digging depth:  18'  feet

**COMMERCIAL EQUIPMENT SERVICE CONTRACT  
TERMS AND CONDITIONS**

**This document sets out the terms and conditions that exclusively govern the Commercial Equipment Service Contract. You are encouraged to familiarize yourself with its contents.**

**1. Definitions:**

(a) As used herein, "Plan" means the Commercial Equipment Service Contract, in respect of the Goods, sold by the Provider to the Customer in return for a payment that is non-refundable to the extent permitted by applicable law.

(b) As used herein, "Provider" means EPG Insurance, Inc.

(c) As used herein, "Customer" means the purchaser of the Plan or an assignee thereof as expressly permitted hereunder.

(d) As used herein, "New Goods" means eligible equipment that is within the manufacturer's base warranty period or that is up to 4 months beyond the manufacturer's base warranty period subject to prior approval by the Provider and pre-existing condition limitations, or as otherwise defined by the Provider.

(e) As used herein, "Used Goods" means eligible equipment that is beyond the manufacturer's base warranty period.

**2. The Plan is a contract between the Provider and the Customer under which the Provider agrees to protect certain specified whole goods purchased by the Customer (the "Goods") according to the terms and conditions set out herein. THE SCOPE AND EFFECTIVENESS OF THE PLAN IS HEREBY LIMITED EXCLUSIVELY TO THE TERMS AND CONDITIONS EXPRESSED HEREIN, AND THE CUSTOMER IS BOUND BY THESE TERMS AND CONDITIONS.**

**3. Protection under the Plan applies, exclusively, to specified New Goods or Used Goods sold and registered by authorized dealerships in the United States and operated exclusively in the United States, Puerto Rico and Canada.**

**4. Protection under the Plan is limited to reimbursement of the cost of parts, and labor for repairs, approved by the Provider, and made by a service center authorized by the Provider, if a defect in material or workmanship is found in the Goods; provided, however, that such reimbursement, as to Goods classified as "New Goods" at the time they are purchased by the Customer, shall not exceed in aggregate, for all claims made under the Plan, the provided purchase price of the Goods or \$500,000, whichever is less; such reimbursement, as to Goods classified as "Used Goods" at the time they are purchased by the Customer, shall not exceed, in the aggregate for all claims made under the Plan, fifty percent (50%) of the value of the Goods at the time they were purchased by the Customer. The Master Parts Schedule attached hereto, and incorporated herein by this reference, lists the only parts protected under the Plan. Labor hours for repairs will be approved as deemed reasonable by the Provider.**

**5. Defect in material or workmanship means the sudden and unforeseen failure of a covered part arising from any permanent mechanical, electrical or electronic defect, causing a sudden stoppage of its function, necessitating immediate repair or replacement before its normal operation may be resumed.**

**6. Protection under the Plan is limited to repairs to the Goods in accordance with the terms and conditions set out herein in consequence of a request for reimbursement authorized by the Provider for failure, due to defects in parts listed on the Master Parts Schedule, that occurs (a) during the term of the Plan, (b) after the expiration of the term of any applicable manufacturer's base warranty period, or any applicable manufacturer's extended warranty, in respect of such Goods, and (c) in respect of defects in the Goods arising after such expiration.**

**7. If parts are needed to effect an authorized repair, the Provider requires the use of genuine OEM parts and, when offered, the use of genuine OEM remanufactured parts, unless prior written authorization of the Provider is given; such parts shall be protected exclusively under any Replacement Parts Warranty while it remains in effect, and only thereafter under the Plan.**

**8. The Customer shall be solely responsible for payment for travel by personnel of the authorized service center to the Goods to repair them, including, without limitation, payment for the time of such personnel, unless the Plan specifies otherwise.**

**9. Protection under the Plan applies to the exploratory dismantling of the Goods only (a) in the event of a defect within the scope of such protection, and (b) with the prior authorization of the Customer; provided, however, that the Customer shall be responsible for all charges for exploratory dismantling if, as a result of such dismantling, the Provider determines that there has not been a failure that falls within the scope of protection under the Plan.**

**10. The Provider neither offers nor provides to the Customer any warranty, expressed or implied, for any component, or other item, that is separately warranted by such part's manufacturer.**

**11. For New Goods, protection under the Plan begins upon the expiration of any applicable manufacturer's base warranty period including any applicable manufacturer's extended warranty unless otherwise noted on Plan cover page and ends on the earlier of (a) the expiration date of the Plan, or (b) the date on which the Goods have been operated for the maximum number of total machine hours specified under the Plan..**

**12. For Used Goods, protection under the Plan starts on the effective date of the Plan and ends on the earlier of (a) the expiration date of the Plan, or (b) the date on which the Goods have been operated for the maximum number of hours specified under the Plan.**

**13. Any transportation, travel, or other expenses will not be credited toward any applicable deductible, unless the Plan specifies otherwise. For all new equipment, and all used equipment, one deductible will apply to each reported failure.**

**14. To be eligible to receive any payment under the Plan, the Customer must have:**

(a) performed all required maintenance on the Goods, at the recommended intervals specified in the Good's manufacturer's operator's manual, and

- (b) operated the Goods exclusively within their rated capacity as specified in the Good's manufacturer's operator's manual, and
  - (c) Claims must be filed within 30 days of date of repair,
  - (d) All required information shall be provided on the claim reimbursement request form at time of submission,
  - (e) All faulty parts from the failure must be retained for inspection by the Provider until final settlement of the claim has been made,
- and
- (f) Faulty parts from the failure, oil sampling reports, maintenance records and invoices associated with the repair, and photographic evidence documenting the failure and consequential damages shall be provided to the Provider within 30 days of request.

15. THE PROVIDER IS NOT RESPONSIBLE FOR INCIDENTAL OR CONSEQUENTIAL DAMAGES. INCIDENTAL OR CONSEQUENTIAL DAMAGES INCLUDE, BUT ARE NOT LIMITED TO, LOST CROPS, LOST CONTRACTS, LOST INCOME, FINES, THEFT, FIRE, VANDALISM OR COLLISIONS. THE PROVIDER SPECIFICALLY HEREBY EXCLUDE THE IMPLIED WARRANTIES OF MERCHANTABILITY AND FITNESS FOR A PARTICULAR PURPOSE.

16. Protection under the Plan, in respect of Goods classified as "New Goods" at the time the Customer purchased them, may be transferred to a new purchaser (a "New Purchaser") by a Customer at any time during the effective term of the Plan, upon the Provider accepting, from the New Purchaser, a Plan Registration Transfer Form satisfactory to the Provider. To transfer such protection under the Plan from the Customer to the New Purchaser, the Provider must first have received any required application fee as well as such Plan Registration Transfer Form. Such form must include, without limitation, the correct serial number(s) of the relevant Goods. Protection under the Plan in respect of Goods classified as "Used Goods" at the time they were purchased by the Customer may not be transferred.

17. If New Goods, protected under the Plan, are stolen or destroyed within their applicable base warranty period, due to no act, omission, or negligence on the part of the Customer, the Customer may, within six (6) months after such event of theft or destruction, transfer protection under the Plan to goods that are purchased from an authorized dealership at a price acceptable to the Provider in its sole discretion.

18. No person, dealer or agent may in any way alter or extend the terms and conditions expressed herein without the prior written authorization of the Provider. Any accommodation made to the Customer by any party shall not constitute a waiver, modification or extension of the terms and conditions of the Plan as expressed herein.

19. A Customer may upgrade the scope of the Plan applicable to such Customer's Goods, by selecting a different Plan option at any time during the manufacturer's base warranty period applicable to such Goods, upon written request to the Provider and payment to the Provider of any additional cost of such different Plan option.

20. The Plan, and all protection thereunder, shall be void if:

- (a) the Goods protected thereby are modified or altered, except with the prior written consent of the Provider or at the direction of the manufacturer of the Goods,
- (b) the Goods' hour meter is changed or altered, other than by an authorized OEM dealership at the direction of the manufacturer of the Goods,
- (c) the Goods' fuel or hydraulic system is changed or altered, without the prior written consent of the Provider,
- (d) the Goods are used in any application for which they were not designed to be used,
- (e) the Goods are scrapped, salvaged, stolen, junked, or totaled, or
- (f) misrepresentation has occurred on the Commercial Equipment Service Contract Registration as to the application(s) for which the Goods will be used.

21. Any dispute between the Customer and the Provider in respect of a payment due the Customer or the Provider under the Plan shall be referred to a panel of three (3) unrelated authorized repair facilities for review. The ruling shall be determined by the judgement decided by the majority of the chosen repair facilities. If resolve is not achieved by this process, the dispute shall be referred to an arbitrator, in the state of Tennessee, in accordance with the commercial rules of the American Arbitration Association..

22. The Plan gives the Customer specific legal rights and the Customer may also have other rights, which may vary, from state to state.

23. The following limitations and exclusions may not be allowed by some states and shall not apply to the extent not allowed by applicable state law:

- (a) The Plan shall not protect Goods with respect to failure due to operating conditions, accidents, abuse, misuse, neglect, damage, weathering, or failure to follow the recommended adjustments or maintenance as described in the applicable manufacturer's operator's manual. Failure resulting from these factors is not eligible for reimbursement under the Plan.

- (b) The Provider is not responsible for failure resulting from improper repair, or use of parts that are not authorized by the Provider or genuine authorized remanufactured parts.

- (c) Reimbursement under the Plan shall not extend to the replacement of wear items normally replaced during the term of the Plan period, including, but not limited to, lights, flasher switches, ignition points, fuses and belts, brake or clutch linings, knives, bucket cutting edges and teeth, steel or rubber tracks and track components, crawler track pads and track components, crop processing and cutting components, external drive sprockets and chains, soil engaging tools, universal joints, resistors, disk bands, roller bearings and seals on undercarriage, quick couplers and grease fittings, lug nuts and studs, lubricated joints, pins and bushings, shovels and sweeps, and accessories or items replaced solely at the Customer's preference.



(d) Reimbursement under the Plan shall not extend to:

(i) normal maintenance parts and service, including, but not limited to, replenishment of oils, lubricants, spark plugs, coolants, thermostats, filters, and fuel injectors; provided, however, that lubricants, filters, and coolants may qualify for Plan reimbursement if they require replacement as a direct result of a defect in material or workmanship;

(ii) costs for coolant, fuel, or lube oil analysis, or supplies and lab recommendations relating thereto;

(iii) customer comfort items including, but not limited to: air and water leaks caused by aged weather stripping, carpets and floor mats, faded paint or rust, decals, mirrors, glass, hinges, interior cab moldings and panels, knobs for switches and handles, exterior/interior door latches, radios and tape players, noise, rattles, seat cushions, and squeaks.

(iv) repairs related exclusively to noise, such as rattles and squeaks;

(v) Goods covered by warranties or extended warranties, including, but not limited to, tires, batteries, fuel injection, transmissions, engines and advanced farming systems;

(vi) travel costs associated with transporting Goods to and from the location of repair without the prior written authorization of the Provider, unless the Plan specifies otherwise;

(vii) failure arising from the use of attachments not authorized in advance in writing by the Provider;

(viii) failure arising from the storage or deterioration of, or failure to properly maintain, the Goods, or negligence, improper use of the Goods, collision, accident, vandalism, fire, or other peril or casualty, or operation of the Goods beyond their rated capacity or specifications;

(ix) charges for labor performed other than by a service center authorized in advance in writing by the Provider;

(x) failure arising from abuse or neglect, including, but not limited to, operation without adequate coolant or lubricants, adjustments to the fuel system outside the Goods' manufacturer's specifications, illegal or improper speeding, or from improper storage, starting, warm-up, or shutdown practices, or use of incorrect or contaminated fuel, oil or other fluids; or failure arising from non-compliance with instructions provided by the manufacturer to prevent such failure;

(xi) failure of the Goods, their implements or attachments caused by improper field application, or overloading, beyond the manufacturer's specifications;

(xii) costs charged for overtime labor costs or out-of-shop expenses;

(xiii) economic loss, including, but not limited to, lost profits, crop loss, or cost of equipment rental;

(xiv) the cost of cleaning of Goods, in preparation for servicing;

(xv) loss or damage of the Goods during shipment;

(xvi) claims involving Goods damaged in transit or handling and subsequently sold as "salvage" Goods;

(xvii) the cost of initial setup or installation of any optional equipment or attachments to the Goods;

(xviii) items used for repairs, including, but not limited to, solvents, cleaners, anti-seize lubricants, oil-dry, special tools, shop towels, or other shop supplies;

(xix) the cost of normal maintenance services, including, but not limited to, checks, adjustments, and shimming, engine tune-ups, replacement of fuses, and engine fuel system cleaning, such as replacing fuel filters, cleaning, setting, or replacement of components due to fuel contamination, normal wear and/or low pressure, and repair of corrosion, decay and deterioration to items such as radiators and coolers;

(xx) repairs subsequent to, or in connection with, unauthorized modification of, or "field fixes" to, the Goods;

(xxi) claims in respect of a complete assembly, if the combined cost of parts and labor to repair the assembly are 75% or less than the replacement cost of the entire assembly, other than with the prior written authorization of the Provider;

(xxii) claims in respect of the inspection or reconditioning of the Goods;

(xxiii) any duplicate, repeat, or comeback repair resulting from improper diagnosis, testing, or poor service work within sixty (60) days after a protected failure;

(xxiv) the cost of removing optional equipment or attachments that were installed without the prior written permission of the Provider, including, but not limited to, loaders, duals, and tanks;

(xxv) Goods sold "as is", other than with the written authorization of the Provider at the time of sale;

(xxvi) lost or stolen equipment;

(xxvii) costs related to the failure of a part replaced pursuant to an OEM parts warranty;

(xxviii) original equipment repair of Goods covered by a warranty issued to the retail purchaser; or repair covered by the manufacturer under a field campaign or recall policy;

(xxix) diagnosis, except according to published OEM labor time schedules in respect of hydraulic pump testing;

(xxx) parts or repairs covered by a warranty supplied by the parts manufacturer;

(xxxi) repairs to remanufactured fuel injection pumps (as such pumps must be replaced);

(xxxii) ensuing loss arising from a failure, including, without limitation, such loss caused by fire;

(xxxiii) severe usage, unless the Plan provides otherwise;

(xxxiv) severe duty applications, including, without limitation, the use of Goods in demolition, foundry, scrap, waste recycling, landfill, mining, tree mowing, or forestry work or in the warehousing of chemicals, unless the Plan specifies otherwise.

(e) Reimbursement under the Plan shall not extend to failure due to tampering with, adjustments or additions of components to, or replacements for Goods, when such actions could contribute to increasing the published horsepower rating of any engine-powered Goods.

(f) Any part installed on the Goods, if such part is under a manufacturer's whole goods warranty or service parts warranty, shall be deemed to be under whichever of such warranties that terminates last.

24. THE REMEDIES OF HAVING A DEFECT IN MATERIAL OR WORKMANSHIP REPAIRED, OR HAVING DEFECTIVE MATERIALS REPLACED, AT A SERVICE CENTER AUTHORIZED BY THE PROVIDER UNDER THE TERMS AND CONDITIONS OF THE PLAN ARE THE CUSTOMER'S EXCLUSIVE REMEDIES UNDER THE PLAN AND ARE IN LIEU OF ANY OTHER REMEDY OR REMEDIES OTHERWISE AVAILABLE.

25. Only the Provider has any liability in respect of claims made under the Plan.

26. The Plan does not provide protection in respect of any agricultural tractor used in a scraper, earthmoving or non-agricultural application for which the Customer receives compensation unless such tractor is designated by its manufacturer as suitable for such application. A Customer using a scraper on his or her own farm to level land for agricultural crop preparation may use an agricultural tractor in such application for not more than (50%) of such tractor's total annual hours of operation; exceeding this limit in any period of twelve (12) consecutive months will make such tractor ineligible for further protection under the Plan. Use of an agricultural tractor in any of the following commercial applications will make such tractor ineligible for further protection under the Plan: site preparation, excavation, pond-building and forestry applications.

27. The terms and conditions set out herein supercede and replace any and all agreements, representations, understandings, and terms and conditions whatsoever made by any party whatsoever prior to the issuance hereof to the Customer and contain the entire understanding of the Customer, and all other parties named herein, with respect to the subject matter hereof. The unenforceability of any term or condition set out herein shall not be construed to limit the enforceability of any other term or condition set out herein. The waiver or non-enforcement by a party named herein, other than the Customer, of a right, requirement, term or condition set out herein shall not operate in law or in equity to prevent such party from later enforcing such or similar rights, requirements, terms or conditions. No changes may be made to the Plan unless approved by the Provider in writing.

28. The Plan shall be interpreted for all purposes in accordance with the laws of the state of Tennessee.

29. The Plan does not guarantee days or time of service. The Provider is not liable for any damages whatsoever arising out of delays, either before or after a day or time of service is agreed upon.

30. If the Provider pays for repairs under this Plan and the Customer is also repaid for the same repairs by someone else, the Customer's payment will become the Provider's property up to the amount that the Provider paid for the repairs.



# TEREX

## TEREX CONSTRUCTION AMERICA'S EXTENDED SERVICE PROTECTION PLAN

Provided by: EPG Insurance, Inc in the United States & Terex Corporation in Canada

This extended service protection plan is not a component life guarantee; it is intended to provide coverage for covered parts – as listed herein – that are defective in material or workmanship. Reference your certificate of coverage declaration page for applicable coverage type.

### POWERTRAIN

Covers the following components listed under the Engine, Drive Line, Differential/Final Drive and Transmission

#### ENGINE

Accessory Gears  
 Camshaft  
 Camshaft Bearings  
 Camshaft Drive Gear  
 Connecting Rods & Bearings  
 Crankshaft  
 Crankshaft Bearings & Gear  
 Cylinder Heads  
 Cylinder Liners  
 Damper  
 Drive Train Electronic Control Module  
 Engine Block  
 Engine Mounts  
 Engine Exhaust Brakes  
 Engine oil cooler and after cooler  
 Engine speed controls & linkages (including fuel shut down solenoids)  
 Fuel Transfer Pump(s)  
 Flywheel, Ring Gear  
 Front & Rear Crankshaft Seals  
 Front and Rear Engine Covers  
 Injection Pump  
 Injectors  
 Intake and Exhaust Manifolds and Gaskets  
 Oil Hoses (Except due to Freezing)  
 Oil Pan  
 Oil Pump  
 Pistons & Rings  
 Rocker Arm Assembly  
 Thermostats  
 Timing Gears  
 Turbocharger  
 Valve Cover  
 Water Pump  
 Water Hoses/Tubes (Except due to Freezing)  
 .....and all parts within the above systems

#### DRIVE LINE

Axle Shaft  
 Drive Shaft  
 Drive Shaft Support Bearing  
 Universal Joints

#### DIFFERENTIAL / FINAL DRIVE

Differential Housing  
 Differential Pinion Gear / Ring Gear  
 Drive Axle Hub  
 Final Drive Planetary Gears  
 Final Drive Pinion  
 Planetary Gear Carrier

#### DIFFERENTIAL / FINAL DRIVE (HYDROSTATIC UNITS)

Control Valve (Travel and Swing and Swing Functions only)  
 Hydraulic Drive / Travel Motor  
 Hydraulic Drive Pump  
 Swing Motor and Swing Gear Box  
 Travel & Swing sections of valve, Excludes Dig Functions

#### TRANSMISSIONS

Clutch Discs (wet only)  
 Clutch Plates (wet only)  
 Counter Shaft Clutch  
 Hydraulic Transmission-Control Valve  
 Hydrostatic Motor  
 Hydrostatic Transmission Charge Pump  
 Hydrostatic Transmission Pump  
 Internal Transmission Control Linkage  
 Internal Wet Service Brakes  
 Main Control Valve Block (including internal harnesses and solenoids)  
 PTO Drive  
 Splitter Drive  
 Torque Converter  
 Torque Converter Pump  
 Transfer Drive / Drop Box  
 Transmission Electronic Control Module  
 Transmission Case  
 Transmission Gears, Bearings, & Shafts  
 Transmission Mounts  
 Transmission Pump  
 Wet Steering Clutches  
 .....and all parts within the above systems

#### ADDITIONAL POWERTRAIN COVERED COMPONENTS FOR SELECT EQUIPMENT TYPES ARE AS FOLLOWS:

#### COMPACTION/PAVING

#### EQUIPMENT COMPONENTS

Eccentric Mechanism & Bearings  
 Propulsion System Hydraulic  
 Pump Drive  
 Reduction Unit  
 Splitter box  
 Torque Hubs  
 Vibration System Hydraulic

#### LIGHT TOWERS

Generator housing (plus all internal Parts)

#### POWERTRAIN EXCLUSIONS (ALL EQUIPMENT TYPES)

Air conditioning compressor/clutch, antifreeze, batteries, belts, breathers, brake disc and plates, burnt and/or pitted valves, electrical components, elements, external seals, gages, hoses and fittings (except where listed as covered), lubricants, oil and filters, pulleys, radiator, wiring harnesses, and adjustments

Terms Conditions: 1.1.2010

MPS: Terex Construction Americas ESPP Effective Date: 10.27.2010

TEREX\_TCMP5\_NEW\_US\_EN\_10.27.2010



# TEREX

## TEREX CONSTRUCTION AMERICA'S EXTENDED SERVICE PROTECTION PLAN

Provided by: EPG Insurance, Inc in the United States & Terex Corporation in Canada

This extended service protection plan is not a component life guarantee; it is intended to provide coverage for covered parts – as listed herein – that are defective in material or workmanship. Reference your certificate of coverage declaration page for applicable coverage type.

### POWERTRAIN PLUS

Covers the Components Listed under Powertrain *Plus* the Components listed under Hydraulics and/or Electronics  
(Refer to your certificate of coverage)

#### HYDRAULICS

(everything in Powertrain plus)

Hydraulic cylinders.  
Hydraulic oil coolers  
Hydraulic Pumps  
Hydraulic Valves  
Hydraulic Motors  
Hydraulic reservoir  
Pilot controls.

#### POWERTRAIN PLUS HYDRAULIC

#### EXCLUSIONS

External seals, external o-rings and external bonded washers, hoses, quick couplers, filters, pipes, breathers, oil

#### ELECTRONICS

(everything in Powertrain plus)

Electric Joysticks  
Frame Level Control  
Gauges  
Indicators  
Instruments  
Motors  
Sensors  
Solenoid Valves  
Starter and Starter Solenoid  
Switches  
Traction Control System  
Voltage Regulator  
Wiring Harnesses (Excludes loose or corroded connections)

### FULL MACHINE

(Covers components listed under Powertrain, Powertrain + Hydraulics, Powertrain + Electronics, *plus* the following listed components)

#### ENGINE

Air to air aftercooler  
Engine fan and fan hub  
Filter mount  
Fuel lines  
Fuel tank  
Fuel transfer pump & gasket  
Oil filler tube  
Pulleys  
Radiator & mounts

#### BRAKES

Brake accumulator  
Brake coolers  
Brake pump, Brake valve  
Pressure reducing valve  
Unloading valve

#### FACTORY INSTALLED AIR

Accumulator  
Clutch  
Compressor  
Condenser  
Dryer  
Evaporator  
Expansion valve  
Pulley  
Seals & gaskets  
Temperature control programmers

#### TRANSMISSION / AXLES /

#### HYDROSTATICS

Control Rods  
External oil lines  
Filler tubes (transmission)  
Oil Cooler

#### SUSPENSION

Front Ride Struts  
Rear Ride Struts

#### STRUCTURE

A-frame  
Articulation joint (incl pins & bushings)  
Backhoe Booms  
Bin frame  
Car body  
C-Frame  
Circle frame  
Dippers  
Draft frame  
Engine frame  
Equipment frame  
Forklift Masts  
Grapple arch and grapple boom  
Loadall Booms  
Loader Arms  
Main Frames  
Moldboard lift arm  
Rollover protection structure (ROPS)  
Side frame  
Swing frame  
Track frame  
X-frame  
Z-bar

#### FULL MACHINE EXCLUSIONS

Brake drums, brake calipers, brake linings, brake hoses, carriages, external seals and gaskets, forks, oil leaks, pins and bushings (unless listed as covered), kingpost, loader/backhoe links, "extra-dig" extending dipper wear strips, deterioration due to use of non factory approved attachments, front shovels/buckets, backhoe buckets, including teeth/side-cutters,

# TRACTOR LOADER BACKHOE

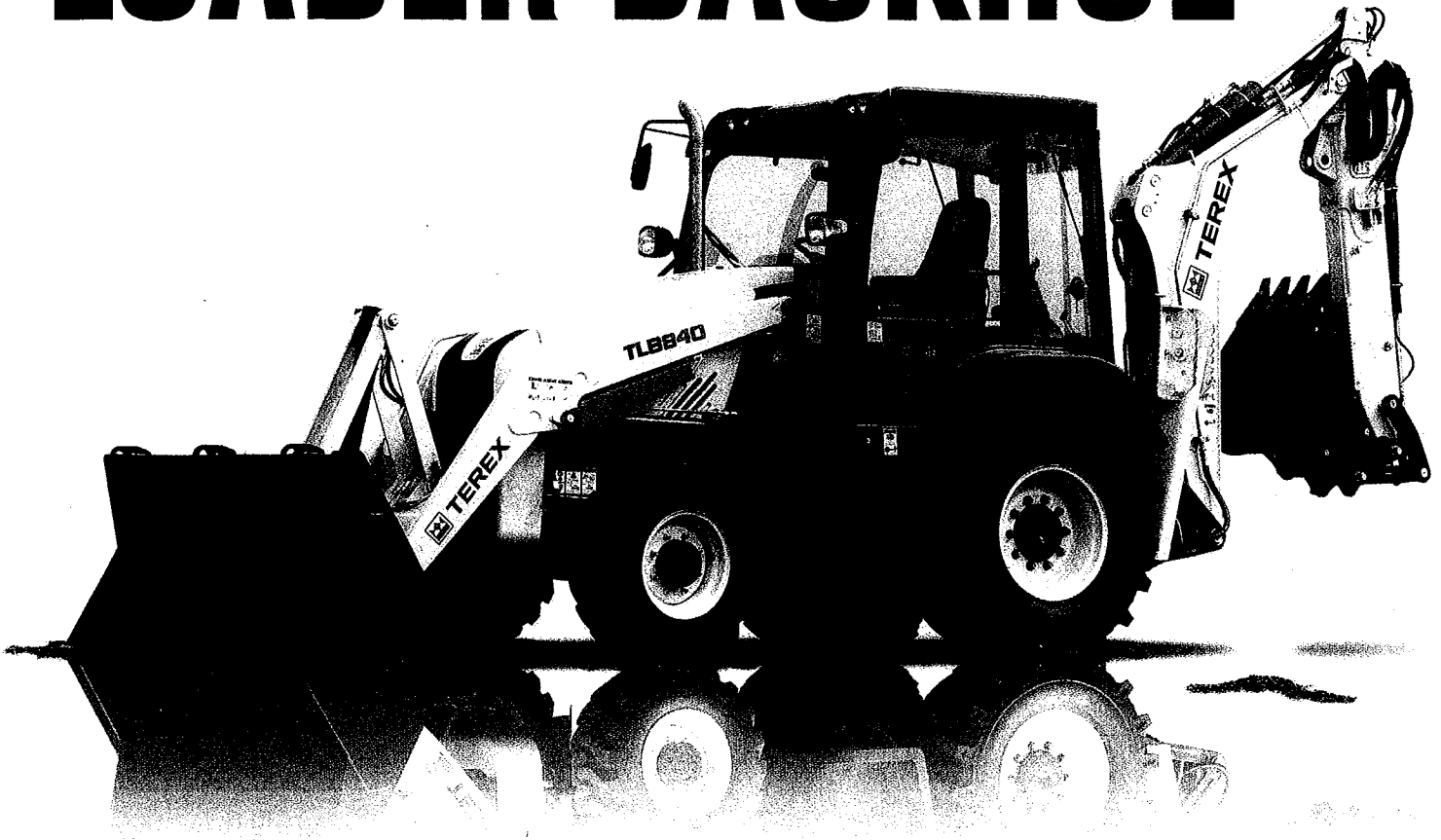

## Specifications

Max Gross Vehicle Weight	15,895 lbs (7210 kg)
Net Engine Power	88 hp (65.7 kw)
Dig Depth (Standard)	14.9 ft (4490 mm)
Dig Depth (Extended)	18 ft (5510 mm)

## Features

- ▶ New slew system provides high torque for easier backfilling and slewing uphill
- ▶ High dipper and bucket digging forces for high productivity trenching
- ▶ Superb visibility for improved driver comfort and productivity
- ▶ Mechanical suspension seat with lumbar support with flip up arm rests for maximum comfort
- ▶ Loading height of 11.3 ft (3.5 m) for easy loading of high sided trucks
- ▶ Hydro mechanical self leveling avoids spillage and allows load retention at full height

**WORKS FOR YOU.™**

# SPECIFICATIONS

## ENGINE

Perkins 1104D-44TA (Tier 3) with Wastegate turbocharger and charge air cooling. Torque rise 31%. Mechanical fuel injection. Stainless steel muffler and exhaust stack. 500 hour service period.	
Cylinders	4
Capacity	269 in <sup>3</sup> (4.4 L)
Rated Speed	2200 rpm
Gross Power @ 2200 rpm SAE J 1995	93.8 hp (70 kW)
Derived Net Rating @ 2200 rpm SAE J 1349	88.1 hp* (65.7 kW*)
Max Torque @ 1400 rpm UN/ECE R120 80/1269/EEC	291 bfft* (395 Nm*) 274 bfft* (372 Nm*)

\* Nominal Non-certified Values

## ELECTRONICS

Wiring And Connectors Meet IP69 Standard	140 A/hr dual batteries with 1260 CCA - EN Standard
12-volt Negative Ground	100 A/hr single battery with 830 CCA - EN Standard
Jump Start Posts	100 amp alternator
Blade Type Fuses	Maintenance free battery
Battery Isolator	

## CAPACITIES

Fuel Tank	31.1 gal (140 L)
Engine Coolant	3.5 gal (16.0 L)
Engine Oil (including filter)	1.9 gal (8.5 L)
Synchro Shuttle Transmission	3.3 gal (15.0 L)
Power Servo Synchro Transmission	3.3 gal (15.0 L)
Rear Axle (including final drives)	3.4 gal (15.5 L)
Front Axle (including final drives)	2.1 gal (9.5 L)
Hydraulic Tank	20.4 gal (92.0 L)

## AXLES AND BRAKES

Outboard planetary final drives for easier servicing. Foot operated differential lock with 100% lockup. 16° front axle oscillation to maintain maximum ground contact and traction. High capacity outboard mounted wet disc brakes. Self equalizing and self adjusting. Selectable 2 or 4 wheel braking.

Axle Ratings	Max Static Loading	Max Dynamic Loading
Front	50602 lb (225 kN)	20259 lb (90 kN)
Rear	42169 lb (187.5 kN)	16867 lb (75 kN)

## TOTAL MACHINE WEIGHT

Total Machine Weight	15895 lbs (7210 kg)
1.32 yd <sup>3</sup> (1 m <sup>3</sup> ) Multi-Purpose Bucket	728 lbs (330 kg)
1.32 yd <sup>3</sup> (1 m <sup>3</sup> ) Multi-Purpose Fork Kit	330 lbs (150 kg)
Deep Dig Dipper	584 lbs (265 kg)
ROPS	-330 lbs (-150 kg)

## TRANSMISSION

4 speed synchro shuttle gearbox. Modulated forward and reverse clutch packs enable smooth direction changes. De-clutch button on shift lever. Direction control with neutral safety interlock. Single stage torque converter with 3.01:1 stall ratio.

Tires	Front	12.5 x 18	12.5/80 x 18	12.5/80 x 18
Rear	18.4 x 26	16.9 x 28	16.9 x 30	
Travel Speeds Forward/Reverse				
1st	3.6 mph (5.7 Km/h)	3.5 mph (5.7 Km/h)	3.7 (5.9 Km/h)	
2nd	5.7 mph (9.2 Km/h)	5.7 mph (9.1 Km/h)	5.9 (9.6 Km/h)	
3rd	12.6 mph (20.3 Km/h)	12.4 mph (20.0 Km/h)	13.0 (21.0 Km/h)	
4th	25.1 mph (40.5 Km/h)	24.8 mph (40.0 Km/h)	25.6 (41.0 Km/h)	

4 speed Servo Power Synchro. Automatic and manual shifting in all 4 gears. Push button kickdown and kick up in 1st and 2nd gear. Auto drop down from 4th to 3rd and back. Single stage torque converter with 3.01:1 stall ratio.

Tires	Front	12.5 x 18	12.5/80 x 18	12.5/80 x 18
Rear	18.4 x 26	16.9 x 28	16.9 x 30	
Travel Speeds Forward/Reverse				
1st	3.6 mph (5.7 Km/h)	3.5 mph (5.7 Km/h)	3.7 (5.9 Km/h)	
2nd	5.7 mph (9.2 Km/h)	5.7 mph (9.1 Km/h)	5.9 (9.6 Km/h)	
3rd	12.6 mph (20.3 Km/h)	12.4 mph (20.0 Km/h)	13.0 (21.0 Km/h)	
4th	25.1 mph (40.5 Km/h)	24.8 mph (40.0 Km/h)	25.6 (41.0 Km/h)	
Travel Speeds Reverse				
1st	3.6 mph (5.7 Km/h)	3.5 mph (5.7 Km/h)	3.7 (5.9 Km/h)	
2nd	5.7 mph (9.2 Km/h)	5.7 mph (9.1 Km/h)	5.9 (9.6 Km/h)	
3rd	12.6 mph (20.3 Km/h)	12.4 mph (20.0 Km/h)	13.0 (21.0 Km/h)	

## TURNING CIRCLES

	Over Tires	Over Bucket
Without Brakes	25.9 ft (7.9 m)	34.7 ft (10.6 m)
With Brakes	23.0 ft (7.0 m)	31.10 ft (9.7 m)

## TIRES

Front	Tractor Industrial 12.5/80 x 18 12 Ply Tubeless
Rear	Tractor Industrial 16.9 x 28 12 Ply Tubeless
Front	Super Traction Loader 12.5 x 18 10 Ply Tubeless
Rear	Tractor Industrial 16.9 x 30 14 Ply Tubeless
Front	Multipurpose 12.5 x 18 10 Ply Agricultural Tubeless
Rear	Agricultural 18.4 x 26 12 Ply Tubeless
Front	Industrial 16/70 x 20 14 Ply Tubeless
Rear	Industrial 16.9 x 30 14 Ply Tubeless

## HYDRAULIC SYSTEM

Tandem Gear Pumps with unloader valve. Open centre control valves. Automatic or manually activated pump flows. Power Boost to match digging power and speed to application. External oil level gauge. Tilting oil cooler. 125 micron suction strainer. 10 micron return line filter.	
Main Pump Flow @ 2200 rpm	21 gpm (80 L/min)
Secondary Pump Flow @ 2200 rpm	16.5 gpm (62 L/min)
System Main Relief Setting	3625 psi (250 bar)
Unloader Settings	3000 psi (207 bar)

# STANDARD EQUIPMENT

TLB840

## CAB AND CANOPY

ROPS/FOPS Conform to ISO 3471/3449	Self-Cleaning Footsteps & Large Grab Handles
Access from Both Sides	Anti Slip Floor Mat (Canopy)
Internal Rear View Mirror	Folding External Rear View Mirrors
2 Cup Holders	Coat Hook
Tilt and Telescopic Steering Wheel	Front and Rear Horn
Seat Storage For Operators Manual	2 in (51 mm) Retractable Seat Belt
Vinyl Seat with Mechanical Suspension ROPS	Standard Fabric Seat with Mechanical Suspension
2 External 12-volt Outlets	Cab with 2 Door Access
Partial Door Locking	Full Depth Up and Over Rear Window
Opening Rear Quarter Windows with Internal Operation	Front and Rear Screen Washers and Wipers
Laminated Windscreen	Tinted Toughened Safety Glass
Heater 22432 btu/hr (657 kW)	Insulated and Chilled Storage Box
Digital Clock	Cell Phone Holder with Power Plug
Pre-Installation of Wiring For Radio	Cab Noise Level 78 dB(a)
12 Audible and Visual Warning Lamps	Digital Clock
Engine Hour Meter	Elapsed Time Counter
3 Gauges For Engine Oil Temp, Fuel and Rpm	4 Rear Work Lights

## LOADER

Hydro-Mechanical Self Levelling	Single Bucket Cylinder
Control Lever with Transmission and Pump Unload Buttons	Standard Bucket 132 yd <sup>3</sup> (1 m <sup>3</sup> ) with Lifting Eye
Reversible Cutting Edge	Bucket Control Lever with Dual Function
Bucket Cylinder Cushioning	Float Position with Positive Hold
Return to Dig	Integral Loader Arm Safety Bar
Bucket Level Indicator	3 <sup>rd</sup> Hydraulic Line with Standard Bucket

## BACKHOE

Curved-Style Boom	Replaceable Serrated Clamping Plates
Standard Dipperstick	Electro/Hydraulic Dual Transport Lock
Option: Outer Slide Deep Dig Dipperstick	Externally Adjustable Lubrication Free Wear Pads (11)
Thumb Cylinder Mounting Bracket Incorporated	Externally Adjustable Stabilizer Wear Pads
SAE/ISO/Diagonal 2 Lever Controls	

## DRIVETRAIN

Synchro Shuttle Transmission 4F/4R Speeds	Servo Power Synchro Transmission 4F/3R Speeds
Direction Control with Neutral Safety Interlock	Transmission De-Clutch on Gear and Loader Controls
Column Mounted Rotational Control Lever	Automatic Up and Down Shifting
Auto Change Down 4/3 and Back	Kick Down 2/1 and Kick Up 1/2
Torque Converter Stall Ratio 3.01:1	Tilting Transmission Oil Cooler
Vertical Element Oil Filter	Outboard Planetary Final Drive Axles
Foot Operated Electro/Hyd Differential Lock	Brakes Self Adjusting and Self Equalizing
Dual Brake Pedals with Combined or Independent Use	Selectable 2 and 4 Wheel Braking In All Gears
Large Capacity Outboard Oil Immersed Disc Brakes <ul style="list-style-type: none"> <li>• 2 Kevlar Friction Discs 11 in (289 mm) Diameter Per Side</li> <li>• Total Friction Area Per Side 24.2 in (156 cm<sup>2</sup>)</li> </ul>	Internal Wet Disc Parking Brake <ul style="list-style-type: none"> <li>-Max Parking Slope (unladen) 1:2</li> <li>-Max Parking Slope (laden) 1:2.5</li> </ul>
4WD standard	Selectable 2WD and 4WD

## ENGINE

Perkins 1104D-44TA (Tier 3)	Anti-freeze Rated to -37° C
Wastegate Turbo and Charge Air Cooled	Vertical Element Secondary Fuel Filter
Electric Fuel Pump	Coolant Expansion Bottle
Mechanical Fuel Injection	Alternator and Fan Drive By Dual V Belt
4 Glow Plug Starting Aid	Gear Driven Water Pump
Horizontal Spin on Oil Filter	Puller Type 9 Bladed Cooling Fan
Primary Fuel Filter with Water Separator	Dual Element Powercore Air Cleaner
Engine Gradeability Fore/Aft and Side/Side 35°	Stainless Steel Muffler and Exhaust Stack
500 Hour Service Period	Fan Guard
Oil to Water Internal Plate Oil Cooler	

## GENERAL

Heavy Duty Chassis Construction	Lockable Side Mounted Toolbox
Fully Tilting Engine Hood	Front Hard Nose Counterweight
Lifting Eyes and Tie Downs (2 Front and Rear)	2 Extra Front Counterweights 92 lbs (42 kg) Each
Reverse Warning Alarm	

# DIMENSIONS

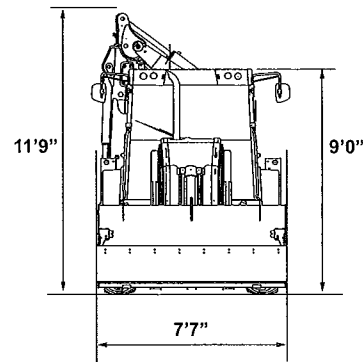
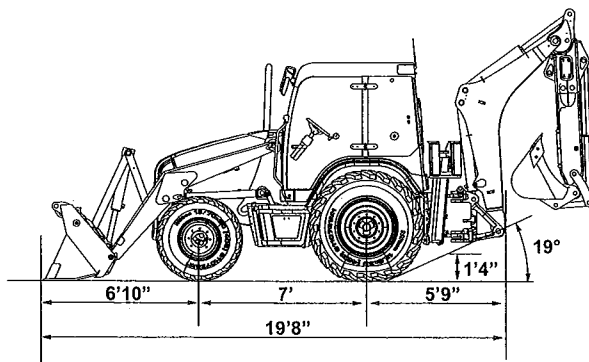
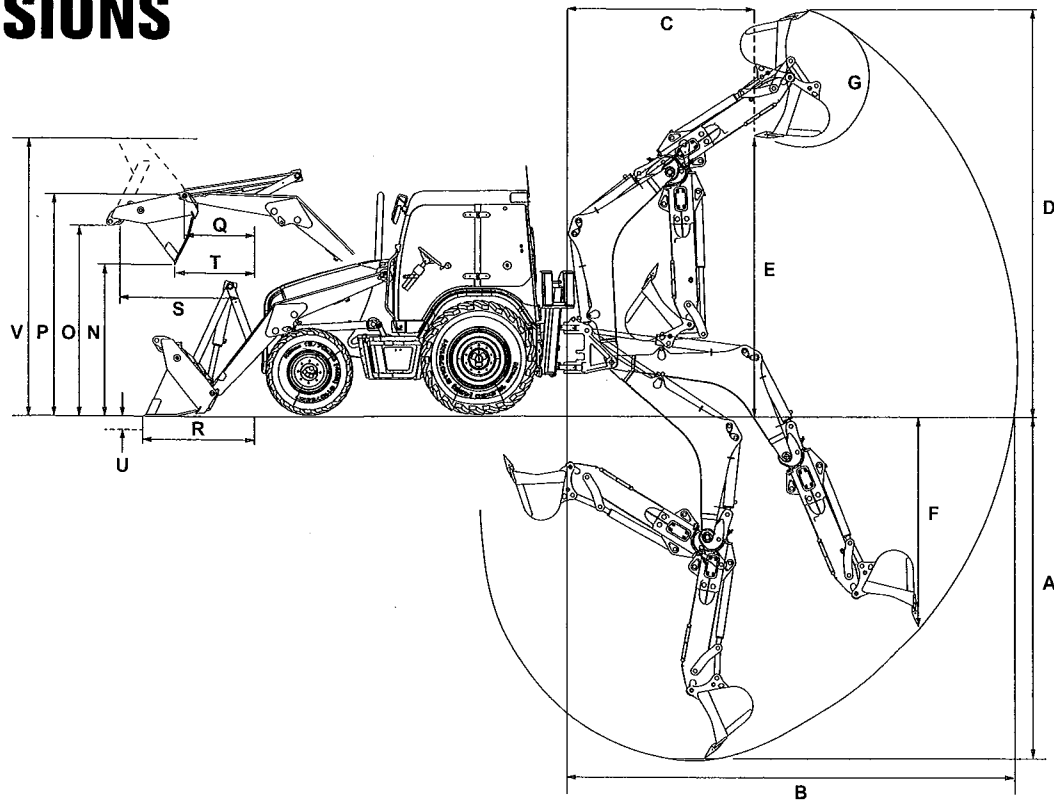

## BACKHOE DIMENSIONS

	Standard Dipper	Deep Dig Dipper	
		Retracted	Extended
A. Maximum Dig-Depth SAE	14.9 ft (4490 mm)	14.9 ft (4490 mm)	18.1 ft (5510 mm)
2 ft Flat Bottom SAE	14.7 ft (4444 mm)	14.7 ft (4444 mm)	17.11 ft (5462 mm)
B. Reach - Ground Level to Slew	18.9 ft (5718 mm)	18.9 ft (5,718 mm)	21.11 ft (6679 mm)
C. Loading Reach	7.6 ft (2280 mm)	7.5 ft (2,250 mm)	10.2 ft (3106 mm)
D. Operating Height	16.9 ft (5093 mm)	16.9 ft (5093 mm)	18.7 ft (5674 mm)
E. Loading-Height SAE	11.17 ft (3518 mm)	11.7 ft (3538 mm)	13.6 ft (4119 mm)
Max Dumping Height	11.0 ft (3340 mm)	11.0 ft (3340 mm)	12.11 ft (3927 mm)
F.	9.2 ft (2802 mm)	9.2 ft (2802 mm)	11.12 ft (3645 mm)
G. Bucket Rotation Degrees			
Speed	194°	196°	196°
Power	164°	166°	166°
Stabilizer Spread	9.9 ft (2980 mm)		
Max. Levelling Angle Degrees	12°		

## LOADER DIMENSIONS

	7-in-1 Bucket
N. Dump Clearance at 45°	9.2 ft (2797 mm)
O. Load-over Height	10.11 ft (3315 mm)
P. Hinge Pin Height	11.10 ft (3562 mm)
Q. Pin Forward Reach	1.0 ft (317 mm)
R. Reach at Ground	4.11 ft (1488 mm)
S. Maximum Reach at Full Height	3.11 ft (1188 mm)
T. Reach at Full Height at 45°	2.5 ft (733 mm)
U. Dig Depth	6 ft (156 mm)
Rollback at Ground	50°
Maximum Dump Angle Fully Raised	47°
V. Overall Operating Height	14.11 ft (4544 mm)



## BACKHOE PERFORMANCE

	Standard Dipper		Deep Dig Dipper	
			Retracted	Extended
Max Slew Torque	18610 lb ft (25.32 kNm)		18610 lb ft (25.32 kNm)	18610 lb ft (25.32 kNm)
Dipper Tearout (SAE J49 Standard)	7958 lbf (35.4 kN)		7958 lbf (35.4 kN)	5890 lbf (26.2 kN)
Bucket Tearout Speed	11892 lbf (52.9 kN)		11802 lbf (52.5 kN)	11802 lbf (52.5 kN)
Power (SAE J49 Standard)	13646 Kn (60.7 kgf)		13511 Kn (60.1 kgf)	13511 Kn (60.1 kgf)

## LOADER PERFORMANCE

	Standard Bucket	7-in-1 Bucket
Bucket Breakout	10485 lbf (46.5 kN)	10097 lbf (44.8 kN)
Arms Breakout	10329 lbf (46.0 kN)	9597 lbf (42.3 kN)
Lift Capacity To Full Height	7291 lbs (3307 kg)	6563 lbs (2977 kg)

## PALLET FORKS

Fork Length	3.6 ft (1067 mm)
Section Width	3 ft (80 mm)
Assembly Weight	336 lbs (153 kg)
Maximum Operating Height	10.2 ft (3097 mm)
Reach at Ground Level	8.10 ft (2660 mm)
Reach at Full Height	7.5 ft (2251 mm)
S.W.L. at 20 in (500 mm) Load Center	2204 lbs (1000 kg)

## CENTER MOUNT BACKHOE

Load Chart for Extending Dipperstick using boom cylinder for object handling (with optional object handling kit)

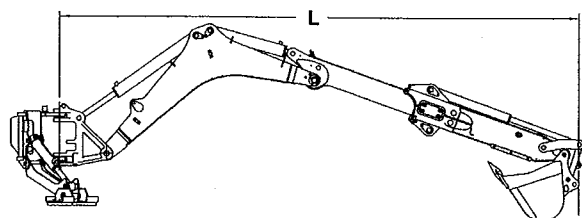

Must have 1.32 yd<sup>3</sup> multipurpose bucket installed to achieve maximum lift capacity

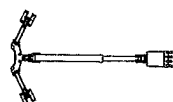

9.3 ft (2.8 m)	12.2 ft (3.7 m)	14.1 ft (4.3 m)	18.0 ft (4.8 m)	17.0 ft (5.2 m)	18.6 ft (5.8 m)
2555 lb (1159 kg)	2136 lb (969 kg)	2087 lb (947 kg)	2076 lb (942 kg)	2037 lb (924 kg)	1968 lb (893 kg)



9.3 ft (2.8 m)	12.2 ft (3.7 m)	14.1 ft (4.3 m)	18.0 ft (4.8 m)	17.0 ft (5.2 m)	18.6 ft (5.8 m)
2555 lb (1159 kg)	2136 lb (969 kg)	1675 lb (760 kg)	1298 lb (589 kg)	1100 lb (499 kg)	917 lb (416 kg)

Load Chart for Standard Dipperstick using boom cylinder for object handling (with optional object handling kit)

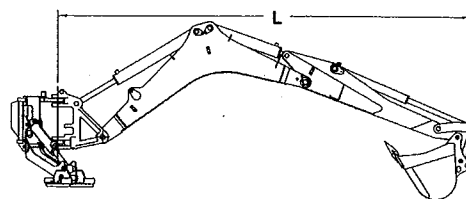

Must have 1.32 yd<sup>3</sup> multipurpose bucket installed to achieve maximum lift capacity

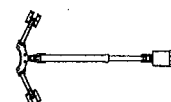

9.3 ft (2.8 m)	12.0 ft (3.6 m)	13.6 ft (4.1 m)	14.6 ft (4.4 m)	16.0 ft (4.8 m)
3018 lb (1369 kg)	2943 lb (1335 kg)	2965 lb (1345 kg)	3024 lb (1372 kg)	3201 lb (1452 kg)



9.3 ft (2.8 m)	12.0 ft (3.6 m)	13.6 ft (4.1 m)	14.6 ft (4.4 m)	16.0 ft (4.8 m)
3018 lb (1369 kg)	2943 lb (1335 kg)	2253 lb (1022 kg)	1931 lb (876 kg)	1706 lb (774 kg)



# State of West Virginia VENDOR PREFERENCE CERTIFICATE

Certification and application\* is hereby made for Preference in accordance with *West Virginia Code*, §5A-3-37. (Does not apply to construction contracts). *West Virginia Code*, §5A-3-37, provides an opportunity for qualifying vendors to request (at the time of bid) preference for their residency status. Such preference is an evaluation method only and will be applied only to the cost bid in accordance with the *West Virginia Code*. This certificate for application is to be used to request such preference. The Purchasing Division will make the determination of the Resident Vendor Preference, if applicable.

- 1. **Application is made for 2.5% resident vendor preference for the reason checked:**  
 Bidder is an individual resident vendor and has resided continuously in West Virginia for four (4) years immediately preceding the date of this certification; **or**,  
 Bidder is a partnership, association or corporation resident vendor and has maintained its headquarters or principal place of business continuously in West Virginia for four (4) years immediately preceding the date of this certification; **or** 80% of the ownership interest of Bidder is held by another individual, partnership, association or corporation resident vendor who has maintained its headquarters or principal place of business continuously in West Virginia for four (4) years immediately preceding the date of this certification; **or**,  
 Bidder is a nonresident vendor which has an affiliate or subsidiary which employs a minimum of one hundred state residents and which has maintained its headquarters or principal place of business within West Virginia continuously for the four (4) years immediately preceding the date of this certification; **or**,
- 2. **Application is made for 2.5% resident vendor preference for the reason checked:**  
 Bidder is a resident vendor who certifies that, during the life of the contract, on average at least 75% of the employees working on the project being bid are residents of West Virginia who have resided in the state continuously for the two years immediately preceding submission of this bid; **or**,
- 3. **Application is made for 2.5% resident vendor preference for the reason checked:**  
 Bidder is a nonresident vendor employing a minimum of one hundred state residents or is a nonresident vendor with an affiliate or subsidiary which maintains its headquarters or principal place of business within West Virginia employing a minimum of one hundred state residents who certifies that, during the life of the contract, on average at least 75% of the employees or Bidder's affiliate's or subsidiary's employees are residents of West Virginia who have resided in the state continuously for the two years immediately preceding submission of this bid; **or**,
- 4. **Application is made for 5% resident vendor preference for the reason checked:**  
 Bidder meets either the requirement of both subdivisions (1) and (2) or subdivision (1) and (3) as stated above; **or**,
- 5.  **Application is made for 3.5% resident vendor preference who is a veteran for the reason checked:**  
 Bidder is an individual resident vendor who is a veteran of the United States armed forces, the reserves or the National Guard and has resided in West Virginia continuously for the four years immediately preceding the date on which the bid is submitted; **or**,
- 6.  **Application is made for 3.5% resident vendor preference who is a veteran for the reason checked:**  
 Bidder is a resident vendor who is a veteran of the United States armed forces, the reserves or the National Guard, if, for purposes of producing or distributing the commodities or completing the project which is the subject of the vendor's bid and continuously over the entire term of the project, on average at least seventy-five percent of the vendor's employees are residents of West Virginia who have resided in the state continuously for the two immediately preceding years.

Bidder understands if the Secretary of Revenue determines that a Bidder receiving preference has failed to continue to meet the requirements for such preference, the Secretary may order the Director of Purchasing to: (a) reject the bid; or (b) assess a penalty against such Bidder in an amount not to exceed 5% of the bid amount and that such penalty will be paid to the contracting agency or deducted from any unpaid balance on the contract or purchase order.

By submission of this certificate, Bidder agrees to disclose any reasonably requested information to the Purchasing Division and authorizes the Department of Revenue to disclose to the Director of Purchasing appropriate information verifying that Bidder has paid the required business taxes, provided that such information does not contain the amounts of taxes paid nor any other information deemed by the Tax Commissioner to be confidential.

**Under penalty of law for false swearing (West Virginia Code, §61-5-3), Bidder hereby certifies that this certificate is true and accurate in all respects; and that if a contract is issued to Bidder and if anything contained within this certificate changes during the term of the contract, Bidder will notify the Purchasing Division in writing immediately.**

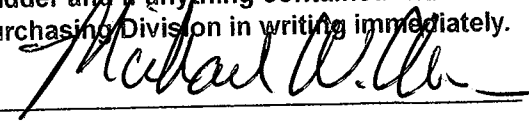
Bidder: Uniontown Industrial Equip.      Signed: 

Date: 6/10/11      Title: V. President

\*Check any combination of preference consideration(s) indicated above, which you are entitled to receive.

RFQ No. 7011EC21

STATE OF WEST VIRGINIA  
Purchasing Division

**PURCHASING AFFIDAVIT**

**West Virginia Code §5A-3-10a states:** No contract or renewal of any contract may be awarded by the state or any of its political subdivisions to any vendor or prospective vendor when the vendor or prospective vendor or a related party to the vendor or prospective vendor is a debtor and the debt owed is an amount greater than one thousand dollars in the aggregate.

**DEFINITIONS:**

"Debt" means any assessment, premium, penalty, fine, tax or other amount of money owed to the state or any of its political subdivisions because of a judgment, fine, permit violation, license assessment, defaulted workers' compensation premium, penalty or other assessment presently delinquent or due and required to be paid to the state or any of its political subdivisions, including any interest or additional penalties accrued thereon.

"Debtor" means any individual, corporation, partnership, association, limited liability company or any other form or business association owing a debt to the state or any of its political subdivisions. "Political subdivision" means any county commission; municipality; county board of education; any instrumentality established by a county or municipality; any separate corporation or instrumentality established by one or more counties or municipalities, as permitted by law; or any public body charged by law with the performance of a government function or whose jurisdiction is coextensive with one or more counties or municipalities. "Related party" means a party, whether an individual, corporation, partnership, association, limited liability company or any other form or business association or other entity whatsoever, related to any vendor by blood, marriage, ownership or contract through which the party has a relationship of ownership or other interest with the vendor so that the party will actually or by effect receive or control a portion of the benefit, profit or other consideration from performance of a vendor contract with the party receiving an amount that meets or exceed five percent of the total contract amount.

**EXCEPTION:** The prohibition of this section does not apply where a vendor has contested any tax administered pursuant to chapter eleven of this code, workers' compensation premium, permit fee or environmental fee or assessment and the matter has not become final or where the vendor has entered into a payment plan or agreement and the vendor is not in default of any of the provisions of such plan or agreement.

Under penalty of law for false swearing (*West Virginia Code §61-5-3*), it is hereby certified that the vendor affirms and acknowledges the information in this affidavit and is in compliance with the requirements as stated.

**WITNESS THE FOLLOWING SIGNATURE**

Vendor's Name: Uniontown Industrial Equipment Co Inc

Authorized Signature: *Michael W. Ober* Date: 6/10/11

State of Pennsylvania

County of Fayette, to-wit:

Taken, subscribed, and sworn to before me this 10<sup>th</sup> day of June, 2011.

My Commission expires June 29, 2011.

AFFIX SEAL HERE

NOTARY PUBLIC

*Tammy L. Bulskin*

COMMONWEALTH OF PENNSYLVANIA

Notary Seal  
Tammy L. Bulskin, Notary Public  
Bulskin, Fayette County  
My Commission Expires June 29, 2011  
Member, Pennsylvania Association of Notaries