



State of West Virginia
 Department of Administration
 Purchasing Division
 2019 Washington Street East
 Post Office Box 50130
 Charleston, WV 25305-0130

Request for Quotation

RFQ NUMBER
 7011EC15

PAGE
 1

ADDRESS CORRESPONDENCE TO ATTENTION OF
 BUYER 33
 304-558-2402

RFQ COPY
 TYPE NAME/ADDRESS HERE

VENDOR

ROPE, INC.
 PO Box 99
 FALLING ROCK, WV 25079

S U P P L I E R

DIVISION OF HIGHWAYS
 EQUIPMENT DIVISION
 ROUTE 33
 BRUSHY FORK ROAD
 BUCKHANNON, WV
 26201 304-472-1750

DATE PRINTED	TERMS OF SALE	SHIP VIA	F.O.B.	FREIGHT TERMS
12/29/2010				

BID OPENING DATE: 02/24/2011 BID OPENING TIME 01:30PM

LINE	QUANTITY	UOP	CAT NO	ITEM NUMBER	UNIT PRICE	AMOUNT
0001	1	EA		570-64	\$13,683.00	
	9 CUBIC YARD	ABRASIVE		AND CHEMICAL SPREADER	EACH	
<p>REQUEST FOR QUOTATION (RFQ) OPEN END CONTRACT</p> <p>THE WEST VIRGINIA STATE PURCHASING DIVISION FOR THE AGENCY, THE WEST VIRGINIA DIVISION OF HIGHWAYS, IS SOLICITING BIDS FOR AN OPEN END CONTRACT TO PROVIDE A 9 CUBIC YARD STAINLESS STEEL DEMOUNTABLE ABRASIVE AND CHEMICAL SPREADER HYDRAULIC PER THE ATTACHED SPECIFICATIONS.</p> <p>TECHNICAL QUESTIONS CONCERNING THIS SOLICITATION MUST BE SUBMITTED IN WRITING TO SHERI SLONE IN THE WEST VIRGINIA STATE PURCHASING DIVISION VIA MAIL AT THE ADDRESS SHOWN IN THE BODY OF THIS RFQ, VIA FAX AT 304-558-2596, OR VIA EMAIL AT SHERI.D.SLONE@WV.GOV. DEADLINE FOR ALL TECHNICAL QUESTIONS IS 01/19/2011 AT THE CLOSE OF BUSINESS. ANY TECHNICAL QUESTIONS RECEIVED WILL BE ANSWERED BY FORMAL ADDENDUM TO BE ISSUED BY THE PURCHASING DIVISION AFTER THE DEADLINE HAS LAPSED.</p> <p>MANDATORY PRE-BID A MANDATORY PRE-BID WILL BE HELD ON TUESDAY, 02/01/2011 AT 11 AM IN BRUSHY FORK RD IN BUCKHANNON, WV 26201. ALL INTERESTED PARTIES ARE REQUIRED TO ATTEND THIS MEETING</p>						

RECEIVED
 2011 MAR 23 PM 1:06
 WV PURCHASING DIVISION

SEE REVERSE SIDE FOR TERMS AND CONDITIONS

SIGNATURE: *[Signature]* TELEPHONE: 304-548-6701 DATE: 2-23-11

TITLE: Sales Coordinator FEIN: 55-0704007 ADDRESS CHANGES TO BE NOTED ABOVE

WHEN RESPONDING TO RFQ, INSERT NAME AND ADDRESS IN SPACE ABOVE LABELED 'VENDOR'

GENERAL TERMS & CONDITIONS REQUEST FOR QUOTATION (RFQ) AND REQUEST FOR PROPOSAL (RFP)

1. Awards will be made in the best interest of the State of West Virginia.
2. The State may accept or reject in part, or in whole, any bid.
3. Prior to any award, the apparent successful vendor must be properly registered with the Purchasing Division and have paid the required \$125 fee.
4. All services performed or goods delivered under State Purchase Order/Contracts are to be continued for the term of the Purchase Order/Contracts, contingent upon funds being appropriated by the Legislature or otherwise being made available. In the event funds are not appropriated or otherwise available for these services or goods this Purchase Order/Contract becomes void and of no effect after June 30.
5. Payment may only be made after the delivery and acceptance of goods or services.
6. Interest may be paid for late payment in accordance with the *West Virginia Code*.
7. Vendor preference will be granted upon written request in accordance with the *West Virginia Code*.
8. The State of West Virginia is exempt from federal and state taxes and will not pay or reimburse such taxes.
9. The Director of Purchasing may cancel any Purchase Order/Contract upon 30 days written notice to the seller.
10. The laws of the State of West Virginia and the *Legislative Rules* of the Purchasing Division shall govern the purchasing process.
11. Any reference to automatic renewal is hereby deleted. The Contract may be renewed only upon mutual written agreement of the parties.
12. **BANKRUPTCY:** In the event the vendor/contractor files for bankruptcy protection, the State may deem this contract null and void, and terminate such contract without further order.
13. **HIPAA BUSINESS ASSOCIATE ADDENDUM:** The West Virginia State Government HIPAA Business Associate Addendum (BAA), approved by the Attorney General, is available online at www.state.wv.us/admin/purchase/vrc/hipaa.htm and is hereby made part of the agreement. Provided that the Agency meets the definition of a Cover Entity (45 CFR §160.103) and will be disclosing Protected Health Information (45 CFR §160.103) to the vendor.
14. **CONFIDENTIALITY:** The vendor agrees that he or she will not disclose to anyone, directly or indirectly, any such personally identifiable information or other confidential information gained from the agency, unless the individual who is the subject of the information consents to the disclosure in writing or the disclosure is made pursuant to the agency's policies, procedures, and rules. Vendor further agrees to comply with the Confidentiality Policies and Information Security Accountability Requirements, set forth in <http://www.state.wv.us/admin/purchase/privacy/noticeConfidentiality.pdf>.
15. **LICENSING:** Vendors must be licensed and in good standing in accordance with any and all state and local laws and requirements by any state or local agency of West Virginia, including, but not limited to, the West Virginia Secretary of State's Office, the West Virginia Tax Department, and the West Virginia Insurance Commission. The vendor must provide all necessary releases to obtain information to enable the director or spending unit to verify that the vendor is licensed and in good standing with the above entities.
16. **ANTITRUST:** In submitting a bid to any agency for the State of West Virginia, the bidder offers and agrees that if the bid is accepted the bidder will convey, sell, assign or transfer to the State of West Virginia all rights, title and interest in and to all causes of action it may now or hereafter acquire under the antitrust laws of the United States and the State of West Virginia for price fixing and/or unreasonable restraints of trade relating to the particular commodities or services purchased or acquired by the State of West Virginia. Such assignment shall be made and become effective at the time the purchasing agency tenders the initial payment to the bidder.

I certify that this bid is made without prior understanding, agreement, or connection with any corporation, firm, limited liability company, partnership, or person or entity submitting a bid for the same material, supplies, equipment or services and is in all respects fair and without collusion or fraud. I further certify that I am authorized to sign the certification on behalf of the bidder or this bid.

INSTRUCTIONS TO BIDDERS

1. Use the quotation forms provided by the Purchasing Division. Complete all sections of the quotation form.
2. Items offered must be in compliance with the specifications. Any deviation from the specifications must be clearly indicated by the bidder. Alternates offered by the bidder as **EQUAL** to the specifications must be clearly defined. A bidder offering an alternate should attach complete specifications and literature to the bid. The Purchasing Division may waive minor deviations to specifications.
3. Unit prices shall prevail in case of discrepancy. All quotations are considered F.O.B. destination unless alternate shipping terms are clearly identified in the quotation.
4. All quotations must be delivered by the bidder to the office listed below prior to the date and time of the bid opening. Failure of the bidder to deliver the quotations on time will result in bid disqualifications: Department of Administration, Purchasing Division, 2019 Washington Street East, P.O. Box 50130, Charleston, WV 25305-0130
5. Communication during the solicitation, bid, evaluation or award periods, except through the Purchasing Division, is strictly prohibited (W.Va. C.S.R. §148-1-6.6).

Rope Inc.



State of West Virginia
 Department of Administration
 Purchasing Division
 2019 Washington Street East
 Post Office Box 50130
 Charleston, WV 25305-0130

Request for Quotation

RFQ NUMBER
7011EC15

PAGE
2

ADDRESS CORRESPONDENCE TO ATTENTION OF
**BUYER 33
 304-558-2402**

VENDOR

RFQ COPY
 TYPE NAME/ADDRESS HERE

ROPE, INC.

SHIP TO

DIVISION OF HIGHWAYS
 EQUIPMENT DIVISION
 ROUTE 33
 BRUSHY FORK ROAD
 BUCKHANNON, WV
 26201 304-472-1750

DATE PRINTED 12/29/2010	TERMS OF SALE	SHIP VIA	FOB	FREIGHT TERMS
-----------------------------------	---------------	----------	-----	---------------

BID OPENING DATE: **02/24/2011** BID OPENING TIME **01:30PM**

LINE	QUANTITY	UGP	CAT NO	ITEM NUMBER	UNIT PRICE	AMOUNT
<p>FAILURE TO ATTEND THE MANDATORY PRE-BID SHALL RESULT IN DISQUALIFICATION OF THE BID. NO ONE PERSON MAY REPRESENT MORE THAN ONE BIDDER.</p> <p>AN ATTENDANCE SHEET WILL BE MADE AVAILABLE FOR ALL POTENTIAL BIDDERS TO COMPLETE. THIS WILL SERVE AS THE OFFICIAL DOCUMENT VERIFYING ATTENDANCE AT THE MANDATORY PRE-BID. FAILURE TO PROVIDE YOUR COMPANY AND REPRESENTATIVE NAME ON THE ATTENDANCE SHEET WILL RESULT IN DISQUALIFICATION OF THE BID. THE STATE WILL NOT ACCEPT ANY OTHER DOCUMENTATION TO VERIFY ATTENDANCE. THE BIDDER IS RESPONSIBLE FOR ENSURING THEY HAVE COMPLETED THE INFORMATION REQUIRED ON THE ATTENDANCE SHEET. THE PURCHASING DIVISION AND THE STATE AGENCY WILL NOT ASSUME ANY RESPONSIBILITY FOR A BIDDER-S FAILURE TO COMPLETE THE PRE-BID ATTENDANCE SHEET. IN ADDITION, WE REQUEST THAT ALL POTENTIAL BIDDERS INCLUDE THEIR E-MAIL ADDRESS AND FAX NUMBER.</p> <p>ALL POTENTIAL BIDDERS ARE REQUESTED TO ARRIVE PRIOR TO THE STARTING TIME FOR THE PRE-BID. BIDDERS WHO ARRIVE LATE, BUT PRIOR TO THE DISMISSAL OF THE TECHNICAL PORTION OF THE PRE-BID WILL BE PERMITTED TO SIGN IN. BIDDERS WHO ARRIVE AFTER CONCLUSION OF THE TECHNICAL PORTION OF THE PRE-BID, BUT DURING ANY SUBSEQUENT PART OF THE PRE-BID WILL NOT BE PERMITTED TO SIGN THE ATTENDANCE SHEET.</p> <p>EXHIBIT 10</p> <p>REQUISITION NO.:</p> <p>ADDENDUM ACKNOWLEDGEMENT</p> <p>I HEREBY ACKNOWLEDGE RECEIPT OF THE FOLLOWING CHECKED</p>						

SEE REVERSE SIDE FOR TERMS AND CONDITIONS

SIGNATURE	TELEPHONE	DATE
TITLE	FEIN	ADDRESS CHANGES TO BE NOTED ABOVE

WHEN RESPONDING TO RFQ, INSERT NAME AND ADDRESS IN SPACE ABOVE LABELED 'VENDOR'



State of West Virginia
 Department of Administration
 Purchasing Division
 2019 Washington Street East
 Post Office Box 50130
 Charleston, WV 25305-0130

Request for Quotation

RFQ NUMBER
7011EC15

PAGE
3

ADDRESS CORRESPONDENCE TO ATTENTION OF
**BUYER 33
 304-558-2402**

RFQ COPY
 TYPE NAME/ADDRESS HERE

ROPE, INC.

**DIVISION OF HIGHWAYS
 EQUIPMENT DIVISION
 ROUTE 33
 BRUSHY FORK ROAD
 BUCKHANNON, WV
 26201 304-472-1750**

DATE PRINTED	TERMS OF SALE	SHIP VIA	FOB	FREIGHT TERMS
12/29/2010				

BID OPENING DATE: **02/24/2011** BID OPENING TIME **01:30PM**

LINE	QUANTITY	UOP	CAT NO	ITEM NUMBER	UNIT PRICE	AMOUNT
<p>ADDENDUM(S) AND HAVE MADE THE NECESSARY REVISIONS TO MY PROPOSAL, PLANS AND/OR SPECIFICATION, ETC.</p> <p>ADDENDUM NO.'S:</p> <p>NO. 1 .. X ..</p> <p>NO. 2 .. X ..</p> <p>NO. 3 .. X ..</p> <p>NO. 4 ..</p> <p>NO. 5 ..</p> <p>I UNDERSTAND THAT FAILURE TO CONFIRM THE RECEIPT OF THE ADDENDUM(S) MAY BE CAUSE FOR REJECTION OF BIDS.</p> <p>VENDOR MUST CLEARLY UNDERSTAND THAT ANY VERBAL REPRESENTATION MADE OR ASSUMED TO BE MADE DURING ANY ORAL DISCUSSION HELD BETWEEN VENDOR'S REPRESENTATIVES AND ANY STATE PERSONNEL IS NOT BINDING. ONLY THE INFORMATION ISSUED IN WRITING AND ADDED TO THE SPECIFICATIONS BY AN OFFICIAL ADDENDUM IS BINDING.</p> <p>..... <i>B. [Signature]</i></p> <p>SIGNATURE</p> <p>..... ROPE, INC.</p> <p>COMPANY</p> <p>..... 2-23-11 3-23-11</p> <p>DATE</p>						

SEE REVERSE SIDE FOR TERMS AND CONDITIONS

SIGNATURE	TELEPHONE	DATE
-----------	-----------	------

TITLE	FEIN	ADDRESS CHANGES TO BE NOTED ABOVE
-------	------	-----------------------------------

WHEN RESPONDING TO RFQ, INSERT NAME AND ADDRESS IN SPACE ABOVE LABELED 'VENDOR'



State of West Virginia
 Department of Administration
 Purchasing Division
 2019 Washington Street East
 Post Office Box 50130
 Charleston, WV 25305-0130

Request for Quotation

RFQ NUMBER
7011EC15

PAGE
4

ADDRESS CORRESPONDENCE TO ATTENTION OF
BUYER 33 304-558-2402

RFQ COPY
 TYPE NAME/ADDRESS HERE

VENDOR

ROPE, INC.

SHIP TO

DIVISION OF HIGHWAYS
 EQUIPMENT DIVISION
 ROUTE 33
 BRUSHY FORK ROAD
 BUCKHANNON, WV
 26201 304-472-1750

DATE PRINTED	TERMS OF SALE	SHIP VIA	FOB	FREIGHT TERMS
12/29/2010				
BID OPENING DATE: 02/24/2011		BID OPENING TIME 01:30PM		

LINE	QUANTITY	UOP	CAT NO	ITEM NUMBER	UNIT PRICE	AMOUNT
<p>NOTE: THIS ADDENDUM ACKNOWLEDGEMENT SHOULD BE SUBMITTED WITH THE BID.</p> <p>REV. 09/21/2009</p> <p>EXHIBIT 2</p> <p>LIFE OF CONTRACT: THIS CONTRACT BECOMES EFFECTIVE ON AND EXTENDS FOR A PERIOD OF ONE (1) YEAR OR UNTIL SUCH "REASONABLE TIME" THEREAFTER AS IS NECESSARY TO OBTAIN A NEW CONTRACT OR RENEW THE ORIGINAL CONTRACT. THE "REASONABLE TIME" PERIOD SHALL NOT EXCEED TWELVE (12) MONTHS. DURING THIS "REASONABLE TIME" THE VENDOR MAY TERMINATE THIS CONTRACT FOR ANY REASON UPON GIVING THE DIRECTOR OF PURCHASING THIRTY (30) DAYS WRITTEN NOTICE.</p> <p>UNLESS SPECIFIC PROVISIONS ARE STIPULATED IN THIS CONTRACT DOCUMENT, THE TERMS, CONDITIONS, AND PRICING SET HEREIN ARE FIRM FOR THE LIFE OF THE CONTRACT.</p> <p>RENEWAL: THIS CONTRACT MAY BE RENEWED UPON THE MUTUAL WRITTEN CONSENT OF THE SPENDING UNIT AND VENDOR, SUBMITTED TO THE DIRECTOR OF PURCHASING THIRTY (30) DAYS PRIOR TO THE EXPIRATION DATE. SUCH RENEWAL SHALL BE IN ACCORDANCE WITH THE TERMS AND CONDITIONS OF THE ORIGINAL CONTRACT AND SHALL BE LIMITED TO TWO (2) ONE (1) YEAR PERIODS.</p> <p>CANCELLATION: THE DIRECTOR OF PURCHASING RESERVES THE RIGHT TO CANCEL THIS CONTRACT IMMEDIATELY UPON WRITTEN NOTICE TO THE VENDOR IF THE COMMODITIES AND/OR SERVICES SUPPLIED ARE OF AN INFERIOR QUALITY OR DO NOT CONFORM WITH THE SPECIFICATIONS OF THE BID AND CONTRACT HEREIN.</p>						

SEE REVERSE SIDE FOR TERMS AND CONDITIONS

SIGNATURE	TELEPHONE	DATE
TITLE	FEIN	ADDRESS CHANGES TO BE NOTED ABOVE

WHEN RESPONDING TO RFQ, INSERT NAME AND ADDRESS IN SPACE ABOVE LABELED 'VENDOR'



State of West Virginia
 Department of Administration
 Purchasing Division
 2019 Washington Street East
 Post Office Box 50130
 Charleston, WV 25305-0130

Request for Quotation

RFQ NUMBER
7011EC15

PAGE
5

ADDRESS CORRESPONDENCE TO ATTENTION OF
BUYER 33 304-558-2402

RFQ COPY
 TYPE NAME/ADDRESS HERE

ROPE, INC.

DIVISION OF HIGHWAYS
 EQUIPMENT DIVISION
 ROUTE 33
 BRUSHY FORK ROAD
 BUCKHANNON, WV
 26201 304-472-1750

DATE PRINTED	TERMS OF SALE	SHIP VIA	F.O.B	FREIGHT TERMS
12/29/2010				

BID OPENING DATE: 02/24/2011 BID OPENING TIME 01:30PM

LINE	QUANTITY	UOP	CAT. NO.	ITEM NUMBER	UNIT PRICE	AMOUNT
<p>OPEN MARKET CLAUSE: THE DIRECTOR OF PURCHASING MAY AUTHORIZE A SPENDING UNIT TO PURCHASE ON THE OPEN MARKET, WITHOUT THE FILING OF A REQUISITION OR COST ESTIMATE, ITEMS SPECIFIED ON THIS CONTRACT FOR IMMEDIATE DELIVERY IN EMERGENCIES DUE TO UNFORESEEN CAUSES (INCLUDING BUT NOT LIMITED TO DELAYS IN TRANSPORTATION OR AN UNANTICIPATED INCREASE IN THE VOLUME OF WORK).</p> <p>QUANTITIES: QUANTITIES LISTED IN THE REQUISITION ARE APPROXIMATIONS ONLY, BASED ON ESTIMATES SUPPLIES BY THE STATE SPENDING UNIT. IT IS UNDERSTOOD AND AGREED THAT THE CONTRACT SHALL COVER THE QUANTITIES ACTUALLY ORDERED FOR DELIVERY DURING THE TERM OF CONTRACT, WHETHER MORE OR LESS THAN THE QUANTITIES SHOWN.</p> <p>ORDERING PROCEDURE: SPENDING UNIT(S) SHALL ISSUE A WRITTEN EQUIPMENT CONTRACT ORDER (FORM NUMBER WV-35) FOR COMMODITIES COVERED BY THIS CONTRACT. THE ORIGINAL WV-35 MUST BE SENT TO THE PURCHASING DIVISION OF THE DEPARTMENT OF ADMINISTRATION. AFTER APPROVAL AND ENCUMBRANCE, ONE COPY OF THE PURCHASE ORDER WILL BE RETURNED TO THE SPENDING UNIT AND ONE COPY FORWARDED TO THE VENDOR AS AUTHORIZATION FOR SHIPMENT. NO ORDER IS VALID UNLESS APPROVED AND ENCUMBERED BY THE PURCHASING DIVISION.</p> <p>BANKRUPTCY: IN THE EVENT THE VENDOR/CONTRACTOR FILES FOR BANKRUPTCY PROTECTION, THE STATE MAY DEEM THE CONTRACT NULL AND VOID, AND TERMINATE SUCH CONTRACT WITHOUT FUTURE ORDER.</p> <p>REV. 5/2009</p> <p>EXHIBIT 4</p>						

SEE REVERSE SIDE FOR TERMS AND CONDITIONS

SIGNATURE	TELEPHONE	DATE
-----------	-----------	------

TITLE	FEIN	ADDRESS CHANGES TO BE NOTED ABOVE
-------	------	-----------------------------------

WHEN RESPONDING TO RFQ, INSERT NAME AND ADDRESS IN SPACE ABOVE LABELED 'VENDOR'



State of West Virginia
 Department of Administration
 Purchasing Division
 2019 Washington Street East
 Post Office Box 50130
 Charleston, WV 25305-0130

Request for Quotation

RFQ NUMBER
7011EC15

PAGE
6

ADDRESS CORRESPONDENCE TO ATTENTION OF:
BUYER 33 304-558-2402

RFQ COPY
 TYPE NAME/ADDRESS HERE

VENDOR

ROPE, INC.

SHIP TO

DIVISION OF HIGHWAYS
 EQUIPMENT DIVISION
 ROUTE 33
 BRUSHY FORK ROAD
 BUCKHANNON, WV
 26201 304-472-1750

DATE PRINTED	TERMS OF SALE	SHIP VIA	F.O.B.	FREIGHT TERMS
12/29/2010				

BID OPENING DATE: 02/24/2011 BID OPENING TIME 01:30PM

LINE	QUANTITY	UOP	CAT NO	ITEM NUMBER	UNIT PRICE	AMOUNT
<p>LOCAL GOVERNMENT BODIES: UNLESS THE VENDOR INDICATES IN THE BID HIS REFUSAL TO EXTEND THE PRICES, TERMS, AND CONDITIONS OF THE BID TO COUNTY, SCHOOL, MUNICIPAL AND OTHER LOCAL GOVERNMENT BODIES, THE BID SHALL EXTEND TO POLITICAL SUBDIVISIONS OF THE STATE OF WEST VIRGINIA. IF THE VENDOR DOES NOT WISH TO EXTEND THE PRICES, TERMS, AND CONDITIONS OF THE BID TO ALL POLITICAL SUBDIVISIONS OF THE STATE, THE VENDOR MUST CLEARLY INDICATE SUCH REFUSAL IN HIS BID. SUCH REFUSAL SHALL NOT PREJUDICE THE AWARD OF THIS CONTRACT IN ANY MANNER.</p> <p>REV. 3/88</p> <p style="text-align: center;">NOTICE</p> <p>A SIGNED BID MUST BE SUBMITTED TO:</p> <p style="text-align: center;">DEPARTMENT OF ADMINISTRATION PURCHASING DIVISION BUILDING 15 2019 WASHINGTON STREET, EAST CHARLESTON, WV 25305-0130</p> <p>THE BID SHOULD CONTAIN THIS INFORMATION ON THE FACE OF THE ENVELOPE OR THE BID MAY NOT BE CONSIDERED:</p> <p>SEALED BID</p> <p>BUYER: SHERI SLONE - FILE 33</p>						

SEE REVERSE SIDE FOR TERMS AND CONDITIONS			
SIGNATURE	TELEPHONE	DATE	
TITLE	FEIN	ADDRESS CHANGES TO BE NOTED ABOVE	

WHEN RESPONDING TO RFQ, INSERT NAME AND ADDRESS IN SPACE ABOVE LABELED 'VENDOR'



State of West Virginia
 Department of Administration
 Purchasing Division
 2019 Washington Street East
 Post Office Box 50130
 Charleston, WV 25305-0130

Request for Quotation

RFQ NUMBER
7011EC15

PAGE
7

ADDRESS CORRESPONDENCE TO ATTENTION OF
BUYER 33 304-558-2402

RFQ COPY
 TYPE NAME/ADDRESS HERE

ROPE, INC.

DIVISION OF HIGHWAYS
 EQUIPMENT DIVISION
 ROUTE 33
 BRUSHY FORK ROAD
 BUCKHANNON, WV
 26201 304-472-1750

DATE PRINTED	TERMS OF SALE	SHIP VIA	F.O.B.	FREIGHT TERMS
12/29/2010				

BID OPENING DATE: **02/24/2011** BID OPENING TIME **01:30PM**

LINE	QUANTITY	UOP	CAT NO	ITEM NUMBER	UNIT PRICE	AMOUNT
RFQ. NO.:				7011EC15		
BID OPENING DATE:				02/24/2011		
BID OPENING TIME:				1:30 PM		
PLEASE PROVIDE A FAX NUMBER IN CASE IT IS NECESSARY TO CONTACT YOU REGARDING YOUR BID:						
				<i>304-548-7186</i>		

CONTACT PERSON (PLEASE PRINT CLEARLY):						
				<i>JOE HOOVER</i>		

***** THIS IS THE END OF RFQ 7011EC15 ***** TOTAL: _____						

SEE REVERSE SIDE FOR TERMS AND CONDITIONS						
SIGNATURE				TELEPHONE		DATE
TITLE			FEIN		ADDRESS CHANGES TO BE NOTED ABOVE	

WHEN RESPONDING TO RFQ, INSERT NAME AND ADDRESS IN SPACE ABOVE LABELED 'VENDOR'

WEST VIRGINIA DEPARTMENT OF TRANSPORTATION
DIVISION OF HIGHWAYS
EQUIPMENT DIVISION

BIDDER'S EVALUATION REPORT

PROCUREMENT SPECIFICATIONS FOR OPEN END CONTRACT
NO. 013-2-C

NINE CUBIC YARD 304 STAINLESS STEEL
DEMOUNTABLE ABRASIVE AND CHEMICAL SPREADER (HYDRAULIC)

NOTE TO BIDDER: Procurement Specification No. 013-2-C, Paragraph 2.0 recommends the completion and submittal of this Report with your bid. Purpose of this Report is to enable the West Virginia Division of Highways Evaluation Committee to make full and fair evaluation of the bid. Addendums in order, along with a summary of exception as a separate attachment, should be with Bidder's Evaluation Report. FAILURE TO SUBMIT THIS REPORT, COMPLETE IN ITS ENTIRETY, MAY SUBJECT THE BIDDER TO DISQUALIFICATION.

Reference Requisition No.: 7011EC15

Bidder's Name: ROPE, INC.

Address: PO Box 99 FALLING ROCK, WV 25079

Telephone Number: 304-548-6701

Years Bidder has been registered to do business with the State of West Virginia: 10+ YRS.

Years Company has been an authorized dealer for proposed unit: LESS THAN 1 YRS.

X3.2 Have you complied with all mandatory specifications? YES NO

X4.2 DELIVERY:

X4.2.1 Delivery date of completed representative unit: 45 Calendar Days After Receipt of Purchase Agreement

X4.2.2 Delivery date of balance of completed units: 135 ~~Calendar Days~~ Calendar Days After Receipt of Purchase Agreement
By Hand

ROPE, INC.

X5.0 AWARD CRITERIA;

X5.1 Price per unit:

\$13,683.⁰⁰ per unit

X6.0 SPECIFICATIONS - GENERAL

X6.1 Manufacturer, model, series, and date of manufacture of proposed unit:

FLINK LMLSH 2011

Is descriptive literature, fully describing proposed unit attached to your bid? YES NO

THE UNIT BID IS BASED ON THE STANDARD FLINK MODEL LML5 SERIES, WHICH
 If not, why? DOES NOT MEET THE SPECIFICATIONS REQUESTED BY THE WVDOT IN
 ITS ENTIRETY. THE UNIT BEING OFFERED WILL HAVE ALL CHANGES NECESSARY TO
 MEET ALL OF THE MANDATORY AND GENERAL SPECIFICATIONS REQUIRED FOR
 A COMPLETE UNIT.

X6.2 Will the required number of service manuals, and complete parts list be delivered to the Equipment Division at Buckhannon upon completion of delivery of total units?

X YES ___ NO

Will the required Equipment Preventive Maintenance Form (Section X6.2 of Bidders Evaluation Report) be provided upon inspection of the pilot unit?

X YES ___ NO

ROPE, INC.

X6.3 TRAINING:

Will training seminar be conducted on Preventive Maintenance, Operator and Mechanic Training YES ___ NO

Will you conduct training with each purchase order against this open end contract? YES ___ NO

Will training be conducted within 2 working days from the delivery of the pilot unit on the individual purchase order? YES ___ NO

If NO, explain time frame _____

Will an Operator's Manual be furnished directly to Training Academy prior to the delivery of the pilot? YES ___ NO

X6.4 If you are the successful vendor, will you furnish all training aids, i.e., videos, projectors, required in conducting the training? YES ___ NO

X6.4.1 Will all manuals, booklets, etc. explaining preventive maintenance, operator procedures, and service schedule be delivered with each unit? YES ___ NO
If NO, explain _____

X6.5 WARRANTY AND SERVICE POLICY

Will the warranty and service you provide comply with all areas as stated in Section 6.5 of specifications YES ___ NO

Is warranty literature attached? YES ___ NO

Is a minimum two (2) year bumper to bumper basic parts and labor warranty excluding abuse and normal wear items included? YES ___ NO

Describe:

SEE WARRANTY STATEMENT

ROPE, INC.

X6.5 WARRANTY AND SERVICE POLICY QUESTIONNAIRE

THIS FORM MUST BE COMPLETED IN ITS ENTIRETY AND SUBMITTED WITH YOUR BID. (If additional lines are needed, make copies of form.)

1. Define the terms of the standard warranty. If not offered, so state. (Attach copy)

ATTACHED

2. Define warranty service to be performed at DOH facilities and warranty service to be performed at manufacturer's representative facility. List name and location of manufacturer's representative.

ALL MAJOR CHANGES TO BE DONE AT DOH FACILITIES
ALL MAJOR CHANGES TO BE DONE AT ROPE, INC. 5522 ELK RIVER ROAD
ELKVIEW, WV

3. List locations for parts inventories that are within the State of West Virginia. Also, list availability levels, if known.

ROPE, INC. 5522 ELK RIVER ROAD, ELKVIEW, WV 25071
NO LEVELS AT THIS TIME.

4. During the term of warranty, list the guarantee discount to manufacturer's published list price for parts that bidder will sell the parts to owner.

- A. Terms: Net 30 Manufacturer's published list price less: 0 % discount
- B. Terms: Net 60 Manufacturer's published list price less: 0 % discount
- C. Terms: Net 90 Manufacturer's published list price less: 0 % discount

5. During the term of warranty, will all manufacturers or engineering improvements be submitted to Division of Highways? X YES NO

6. During the term of warranty, list the guaranteed rates charged for repair to the unit.

A. Shop Rate \$ 7500 per mechanic hour

B. Travel Time Charge \$ 75.00 per mechanic hour
(Specify if one-way) _____; port to port X

C. Mileage Charge \$ 1.40 per vehicle mile
(Specify if one-way) _____; port to port X

D. Field Mechanic Rate \$ 90.00 per mechanic hour

E. Specify period of time that prices are in effect: LIFE OF CONSTRUCT

F. Surcharge for miscellaneous items: 1 %

ROPE, INC.

X6.6 EVALUATION COMMITTEE REQUIREMENTS

Is all component specifications, product literature, component models provided for Evaluation Committee bid determination? YES NO

X6.7 Will all parts, equipment, accessories, material, design and performance characteristics not specified herein, but which are necessary to provide a complete unit, be furnished with the unit and conform in strength, quality of material, and quality of workmanship to those which are advertised and provided to the market in general by the unit industry? YES NO

X6.7.1 Are all parts and accessories adequate and regularly supplied as standard to be included except those which may be duplications of specifications herein, and except these by specification are not to be furnished? YES NO

X6.7.2 Are all standard safety features that are required by Federal and State statutes of law included? YES NO

X7.0 SPECIFICATIONS OF THE QUOTED UNIT

The bidder should complete the following schedule in order for the Division to compare the actual bid unit to the specifications. Should the bidder except a requirement, then such exception may be only on the basis that such feature is not offered by the manufacturer. The Division will have the sole discretion as to whether the bidder's substitution meets the requirements of the specifications.

Manufacturer: FLINK Model: LMCSH

X7.1 Is spreaders offered the commercial heavy duty, self contained, hopper type? YES NO

X7.2 Does spreader consist of a 12 gauge 304 stainless steel body, feeder conveyor, spinner disc, power drive, and all components necessary to make a complete operating unit? YES NO

X7.3 Is the unit capable of uniformly spreading sand, cinders, salt, calcium chloride, or other mixtures up to a width of forty (40) feet? YES NO

X7.4 Body:

X7.4.1 Is the body of 304 stainless steel construction 100% welded inside and outside of the body? YES NO

X7.4.2 Capacity struck: 90 cubic yards

X7.4.3 Inside length: 13 feet as measured from front of spreader hopper to the rear hopper gate and conveyor chain exit point

Rope, Inc.

- X7.4.4 Overall height: 54 inches
- X7.4.5 Inside width: 82 inches
- X7.4.6 Are the body sides sloped approximately 45 degree pitch to insure free flow of materials to the conveyor YES NO
- X7.4.7 Gauge of 304 stainless steel in sides and endgates is 12 Gauge.
- X7.4.8 Is a formed double crimped section on top of body for additional support? YES NO
- X7.4.9 Sills constructed of 10 gauge 304 stainless steel.
Supported on rectangular formed cross sills YES NO
- X7.4.10 Number of 10 gauge full slope body side supports tying the cross sills with body sides? 12 TOTAL
- X7.4.11 Are there four (4) 304 stainless steel 5/8 inch round lifting eyes YES NO
Is the inside eye opening designed to allow the passage of an alloy eye type Grade 80' 3/8 inch grab hook with a width dimension of 2 11/16 inch (with the top screen down in the rest position on top of the spreader) YES NO
Two (2) on each side of spreader mounted and secured in a manner that the entire unit may be safely lifted for storage/installation purposes YES NO
- X7.4.12 Is all necessary hardware stainless steel YES NO
- X7.4.13 Will a 12 gauge 304 stainless steel cabshield be mounted on the front of body to protect cab from falling material when loading with slope design to fall in hopper as spreader unloads? YES NO
Does cab shield extend 13 inches in front of the hopper at 45 degrees YES NO
- X7.4.13.1 Is a 300 series stainless steel grab handle mounted to the drivers side spill shield side plate at a convenient location to assist operator when climbing atop spreader to remove "chunks or debris" YES NO
- X7.4.14 Is a fold up stainless steel ladder be mounted on the rear of spreader body at right side for easier access to top YES NO
Is the ladder equipped with hand holds, non slip strut steps, and manufacturers locking mechanism to lock ladder in up position when not in use YES NO
- X7.4.14.1 Is a 300 series stainless steel grip strut step plate mounted on rear of spreader "spinner" housing frame, above rear baffle, full width of spinner housing YES NO
- X7.4.15 Is a work light mounted on cab shield for night shift visibility of spreader grating with weatherproof wiring YES NO

ROPE, INC.

X7.5 Conveyor:

- X7.5.1 Is the conveyor located in bottom of hopper and capable of engaging material along its full length and moving material to rear adjustable metering gate? YES NO
- X7.5.2 Is conveyor continuous ladder type consisting of two parallel chains with cross bars on 4 2" centers made of 1/4" x 1-1/2" steel? YES NO
- X7.5.3 Is each cross bar formed and welded both top and bottom to chain links YES NO
- X7.5.4 Tensile strength of each chain strand: 21,000 pounds
- X7.5.5 Overall width of chain conveyor: 23 inches
- X7.5.6 Are replaceable rubber wear strips provided to prevent contact of material being spread with the chain? YES NO
- X7.5.7 Is a 10 gauge 304 stainless steel heavy-duty replaceable conveyor plate fitted YES NO
- X7.5.8 Is the chain drive through 1-1/2" sprockets and shafting front and rear? YES NO
- X7.5.9 Does conveyor have adjustment provisions at rear of spreader for at least 3" lateral takeup? YES NO
- X7.5.10 Is additional 7 gauge 304 stainless steel reinforcing plate welded to longitudinal webs covering the area of the drive shaft, bearing, and idler bearing provided (if required)? YES NO
- X7.5.11 Is material composition of adjustment mechanism stainless steel YES NO
- X7.5.12 Is conveyor drive motor mounted on reduction gear box and has a ratio of approximately 50-1 YES NO
- X7.5.13 Does conveyor gear box motor have an integral speed sensor? YES NO
- X7.5.13.1 Is the shaft end machined to accommodate the application rate sensor shaft for the Dickey-John Automatic Control System, Model ICS-2000? YES NO
- X7.5.13.2 Is the necessary oil seal included? YES NO
- X7.5.14 Is a 7 gauge stainless steel adjustable greasable screw jack type discharge gate located at the body rear to adjust the flow of material to the spinner? YES NO
- X7.5.15 Feedgate opening: 12 inches high x 18 inches wide
- X7.5.16 Is any and all exposed moving or rotating mass adequately shielded in order to protect personnel while performing required operational adjustments including gear box extended input shaft when rate sensor is installed? YES NO

ROPE, INC.

X7.5.17 Is the pintle conveyor chain heat treated form links with locked, non-turning pins YES NO

X7.6 Distributor Spinner Assembly:

X7.6.1 Diameter of urethane distributor disc 20 inches

X7.6.1.1 Number of fins: 6

X7.6.1.2 Are fins designed to obtain a controlled spread of materials from four feet (4') to forty feet (40')? YES NO

X7.6.2 Is material guided from conveyor end to distributor disc by means of an externally adjustable material flow baffles, enclosed within the chute? YES NO

X7.6.3 Spinner is vertically adjustable 18 inches and provides a 20-38 inch spinner position below the mounting surface

X7.6.4 Is a deflector baffle or diverter chute provided in an enclosed distributor spinner hopper assembly so it can be positioned in such a manner that material can be unloaded from spreader without striking spinner? YES NO

X7.7 Baffles: YES NO

X7.7.1 Are baffles provided to control direction and width of spread?

X7.7.1.2 Are there four (4) sections over right, left, rear and front of spinners? YES NO

Is front spinner baffle shield (truck side) stationary YES NO

X7.7.2 Are sections easily adjusted from the full down to the horizontal position without use of tools? YES NO

X7.8 Power Drive: YES NO

X7.8.1 Is the power drive hydraulic type?

X7.8.1.2 Are two (2) hydraulic motors provided - one (1) powering the spinner assembly and one (1) powering the conveyor? YES NO

X7.8.2 Spinner hydraulic motor mounted below the spinner hopper assembly? YES NO

X7.8.3 The conveyor hydraulic motor of the orbital, low speed, hi-torque integrally mounted to conveyor gear box? YES NO

X7.9 Screen Over Hopper:

X7.9.1 Are four (4) sectional screens hinged to 10 gauge 304 stainless steel 4 inch x 6 inch formed box beam running longitudinally the full length of spreader hopper? YES NO

If not specify: _____

ROPE, INC.

X7.9.2 Do screen sections have 3/8" diameter carbon steel rods welded forming 2-1/2" x 2-1/2" square openings with reinforcing bars at the center of each section? YES NO

If not specify: _____

X7.9.3 Do screens increase overall height of spreader more than 7 inches down the center? YES NO

X7.9.4 Are screens powder coated black YES NO

X7.10 Is lighting in accordance with the attached sketch and wiring schematic? YES NO

X7.10.1 Is the combination and marker lights LED type YES NO

X7.10.2 Are stop, tail, turn combination lights and marker lights shielded YES NO

X7.10.3 Is strobe light "quad flash" YES NO

X7.11 Hydraulic Components:

X7.11.1 Are all necessary fittings for complete hookup of spreader hydraulics to DOH dump trucks central hydraulic system provided? YES NO

X7.11.2 Are all fittings of the steel type and designed for hydraulic use? YES NO

X7.11.3 Will the hoses mate with the quick disconnects on the central hydraulic system of the truck? YES NO

Will you furnish the male quick disconnects, metal caps, and plugs for connection to truck manifold YES NO

X7.12 Is an anodized 6061T6 aluminum YES NO

(OR)
304 stainless steel YES NO grease manifold block mounted at the rear of the body which incorporates the front bearing grease extension tubes, rear bearing grease fittings and feedgate screw jack lubrication tube to allow for lubrication of the front bearings and feedgate screw jack from a single convenient location? YES NO

Other fittings are placed at convenient location for normal maintenance YES NO

X7.12.1 The anodized 6061T6 aluminum YES NO

(OR)
304 stainless steel grease manifold block YES NO
Has 6 ports tapped to accept three (3) 1/8 inch straight grease zerks and three (3) 1/8 inch grease Parflex hoses to provide adequate one location greasing of the front and rear bearings and feed gate screw jack YES NO

Are any unused ports properly plugged YES NO

ROPE, INC.

X7.12.2 Are hoses used in the grease manifold system Parflex hose by Parker Hannifin or equal, with 1/8 inch I.D., 0.34 inch maximum O.D., a maximum working pressure of 2500 PSI and a minimum burst pressure of 10,000 PSI? YES NO

Are hose assemblies held in place by a sufficient number of rubber cushioned hose clamps? YES NO

X7.13 Is one (1) piece of angle iron 3/8" x 4" X 90" and two (2) pieces of 1" round shafting ten inches (10") long provided but not installed for each unit? YES NO

X7.14 Other standard features:

List other standard features offered but not specifically addressed above:

LOWER SIDE GUSSETS ON HOPPER - 10GA 304SS IN LIEU
OF 12 GA. 304SS (10GA IS THICKER); IDLER ADJUSTMENT
TO BE SPRING CUSHIONED.

X7.15 Paint:

Describe method of painting parts and accessories that are not required to be stainless or rustproof:

SCREEN PANELS ARE POWDER COATED. ALL OTHER CARBON
MATERIAL PARTS ARE CHEMICALLY CLEANED AND PRIMER/FINISH
COAT PAINTED

X7.16 Does unit offered meet or exceed "Occupational Safety and Health Act of 1970"? YES NO

X7.17 Does unit conform to the advertising guidelines? YES NO

ROPE, INC.



State of West Virginia
 Department of Administration
 Purchasing Division
 2019 Washington Street East
 Post Office Box 50130
 Charleston, WV 25305-0130

Request for Quotation

RFQ NUMBER
7011EC15

PAGE
1

ADDRESS CORRESPONDENCE TO ATTENTION OF:
BUYER 33
304-558-2402

VENDOR

*130144526 304-548-7183
ROPE INCORPORATED
PO BOX 99
5522 ELK RIVER RD N
FALLING ROCK WV 25079

SHIP TO

DIVISION OF HIGHWAYS
EQUIPMENT DIVISION
ROUTE 33
BRUSHY FORK ROAD
BUCKHANNON, WV
26201 **304-472-1750**

DATE PRINTED 02/17/2011	TERMS OF SALE	SHIP VIA	F.O.B.	FREIGHT TERMS
-----------------------------------	---------------	----------	--------	---------------

BID OPENING DATE: **02/23/2011** BID OPENING TIME **01:30PM**

LINE	QUANTITY	UOP	CAT. NO.	ITEM NUMBER	UNIT PRICE	AMOUNT
				ADDENDUM NO. 1		
				THIS ADDENDUM IS ISSUED TO:		
				1.) TO PROVIDE CHANGES TO SPECIFICATIONS PER THE ATTACHED		
				2.) CHANGE BID OPENING DATE FROM 02/24/2011 AT 1:30 PM TO 02/23/2011 AT 1:30 PM		
				3.) TO PROVIDE A COPY OF THE MANDATORY PRE-BID ATTENDEE SHEET.		
				*****END ADDENDUM NO. 1*****		
0001	1	EA		570-64		
	9	CUBIC YARD		ABRASIVE AND CHEMICAL SPREADER		
				***** THIS IS THE END OF RFQ 7011EC15 ***** TOTAL:		

SEE REVERSE SIDE FOR TERMS AND CONDITIONS

SIGNATURE <i>B. ...</i>	TELEPHONE 304-548-6701	DATE 2-23-11
TITLE <i>Sales ...</i>	FEIN 55-0704007	ADDRESS CHANGES TO BE NOTED ABOVE

WHEN RESPONDING TO RFQ, INSERT NAME AND ADDRESS IN SPACE ABOVE LABELED 'VENDOR'

PREBID ADDENDUM #1
7011EC15

9 CUBIC YARD STAINLESS STEEL
DEMOUNTABLE ABRASIVE AND CHEMICAL SPREADER (HYDRAULIC)

CHANGES TO BIDDER'S EVALUATION REPORT:

FROM:

X7.2 Does spreader consist of a 12 gauge 304 stainless steel body, feeder conveyor, spinner disc, power drive, and all components necessary to make a complete operating unit? YES NO

TO:

X7.2 Spreader consists of a 12 gauge 304 stainless steel body, feeder conveyor, spinner disc, power drive, and all components necessary to make a complete operating unit? X YES NO

FROM:

X7.4.2 Capacity struck: cubic yards

TO:

X7.4.2 Struck capacity: 9.0 cubic yards

FROM:

X7.5.12 Is conveyor drive motor mounted on reduction gear box and has a ratio of approximately ~~50:1~~ YES NO

TO:

X7.5.12 Is conveyor drive motor mounted on rear of the reduction gear box X YES NO
And ratio of 50:1

NO CHANGE REQUIRED:

X7.6.4 Is a deflector baffle or diverter chute provided in an enclosed distributor spinner hopper assembly so it can be positioned in such a manner that material can be unloaded from spreader without striking spinner? X YES NO

ROPE, INC.

FROM:

X7.10.3 Is strobe light "quad flash" YES NO

TO:

X7.10.3 Is warning light Class 1 LED amber? YES NO

FROM:

X7.13 Is one (1) piece of angle iron 3/8" x 4" x 90" and two (2) pieces of 1" round shafting ten inches (10") long provided but not installed for each? YES NO

TO:

X7.13 Is one (1) piece of angle iron 3/8" x 4" x 4" x 90" and two (2) pieces of 1" round shafting ten inches (10") long provided but not installed for each? YES NO

ROPE, INC.



State of West Virginia
 Department of Administration
 Purchasing Division
 2019 Washington Street East
 Post Office Box 50130
 Charleston, WV 25305-0130

request for
Quotation

RFQ NUMBER
 7011EC15

PAGE
 1

ADDRESS CORRESPONDENCE TO ATTENTION OF
 BUYER 33
 304-558-2402

*130144526 304-548-7183
 ROPE INCORPORATED
 PO BOX 99
 5522 ELK RIVER RD N
 FALLING ROCK WV 25079

DIVISION OF HIGHWAYS
 EQUIPMENT DIVISION
 ROUTE 33
 BRUSHY FORK ROAD
 BUCKHANNON, WV
 26201 304-472-1750

DATE PRINTED	TERMS OF SALE	SHIP VIA	FOB	FREIGHT TERMS
02/23/2011				

BID OPENING DATE: 03/15/2011 BID OPENING TIME 01:30PM

LINE	QUANTITY	UOP	CAT NO	ITEM NUMBER	UNIT PRICE	AMOUNT
ADDENDUM NO. 2						
THIS ADDENDUM IS ISSUED TO EXTEND THE BID OPENING DATE FROM 02/23/2011 AT 1:30 PM TO 03/15/2011 AT 1:30 PM						
*****END ADDENDUM NO. 2*****						
0001	1	EA		570-64		
9 CUBIC YARD ABRASIVE AND CHEMICAL SPREADER						
***** THIS IS THE END OF RFQ 7011EC15 ***** TOTAL:						

SEE REVERSE SIDE FOR TERMS AND CONDITIONS

SIGNATURE <i>B. [Signature]</i>	TELEPHONE 304-548-6701	DATE 2-23-11
TITLE SALES COORDINATOR	FEIN 55-0704007	ADDRESS CHANGES TO BE NOTED ABOVE

WHEN RESPONDING TO RFQ, INSERT NAME AND ADDRESS IN SPACE ABOVE LABELED 'VENDOR'



State of West Virginia
 Department of Administration
 Purchasing Division
 2019 Washington Street East
 Post Office Box 50130
 Charleston, WV 25305-0130

Request for Quotation

RFQ NUMBER
7011EC15

PAGE
1

ADDRESS CORRESPONDENCE TO ATTENTION OF:
**BUYER 33
 304-558-2402**

VENDOR
 *130144526 304-548-7183
ROPE INCORPORATED
PO BOX 99
5522 ELK RIVER RD N
FALLING ROCK WV 25079

SHIP TO
DIVISION OF HIGHWAYS
EQUIPMENT DIVISION
ROUTE 33
BRUSHY FORK ROAD
BUCKHANNON, WV
26201 304-472-1750

DATE PRINTED	TERMS OF SALE	SHIP VIA	F.O.B.	FREIGHT TERMS
03/10/2011				

BID OPENING DATE: **03/23/2011** BID OPENING TIME **01:30PM**

LINE	QUANTITY	UOP	CAT NO.	ITEM NUMBER	UNIT PRICE	AMOUNT
				ADDENDUM NO. 3		
				THIS ADDENDUM IS ISSUED TO EXTEND THE BID OPENING DATE FROM:		
				03/15/2011 AT 1:30 PM		
				TO		
				03/23/2011 AT 1:30 PM		
				*****END ADDEUNDUM NO. 3*****		
0001	1	EA		570-64		
	9 CUBIC YARD			ABRASIVE AND CHEMICAL SPREADER		
				***** THIS IS THE END OF RFQ 7011EC15 ***** TOTAL:		

SEE REVERSE SIDE FOR TERMS AND CONDITIONS

SIGNATURE: *[Signature]* TELEPHONE: _____ DATE: **3-23-11**

TITLE: *[Signature]* FEIN: _____ ADDRESS CHANGES TO BE NOTED ABOVE

WHEN RESPONDING TO RFQ, INSERT NAME AND ADDRESS IN SPACE ABOVE LABELED 'VENDOR'

Snow and Ice Control
Since 1934



502 N. Vermillion Street • Streator, Illinois 61364
(815) 673-4321 • Fax (815) 672-2678
info@flinkco.com • website: www.flinkco.com

WARRANTY

The Flink Company warrants that it will replace without charge within two years of date of sale, any part proven to the satisfaction of Flink Company to have been defective at the time it was sold or became defective through normal use. This warranty applies only to parts which have not been altered, changed, repaired or abused in any manner.

Component parts used in this equipment but furnished by other manufacturers are warranted only to the extent of the warranty supplied by such manufacturers.

The Flink Company is not responsible to any purchaser of our products for any warranty of guarantee made by dealers selling our products beyond that stated above.

FLINK COMPANY
Streator, Illinois

ROPE, INC.

LMC5 Hopper Spreader

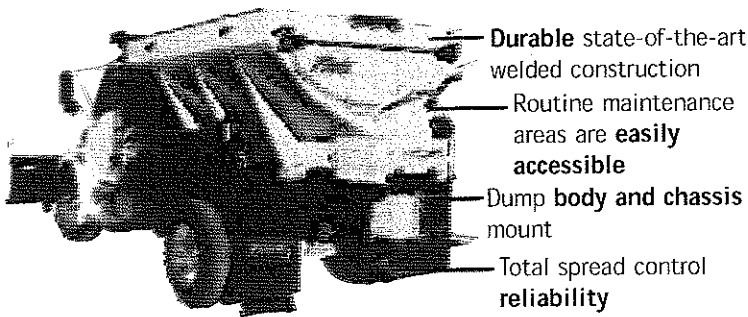

- Durable state-of-the-art welded construction
- Routine maintenance areas are easily accessible
- Dump body and chassis mount
- Total spread control reliability

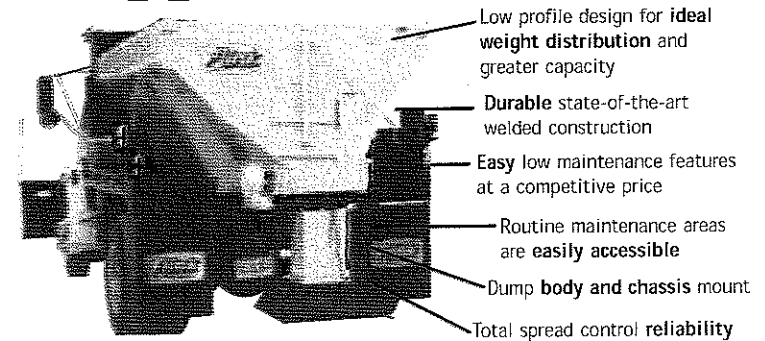

- Low profile design for ideal weight distribution and greater capacity
- Durable state-of-the-art welded construction
- Easy low maintenance features at a competitive price
- Routine maintenance areas are easily accessible
- Dump body and chassis mount
- Total spread control reliability

HOPPER CONSTRUCTION

- 45° Hopper side slope
- #10 gauge steel sides and ends – channel formed at top and continuous welded inside seam
- #10 gauge steel flanged body supports – three minimum per side
- #7 gauge top gusset inside the hopper opposite each side support, extending from top edge down minimum 8" below 45° tapered side
- Material feed gate is adjustable with self-locking screw jack and opening is 10" high x 19" wide
- Lift loops are provided at each corner for easy handling of empty spreader

CONVEYOR

- #7 gauge steel conveyor side rails and floor plate
- Overall width 24" and overall height 10-1/4"
- Sides bolted to conveyor flange
- Chain wiper provided at rear
- 2-1/4" pitch pintle chain (42,000# ultimate) with 3/8" x 1-1/2" half-oval cross bars spaced 4-1/2 on center (every other link)
- Chain shields for drag chain are bolt-on style
- Chain tensioned by spring loaded idler – minimum 3" of adjustment
- Idler roller supported on ball bearings

CONVEYOR DRIVE

- (2)-Char-Lynn drive motors, one each end of conveyor drive, 50:1 high efficiency chain and sprocket reduction, provides higher torques and conveyor speeds
- 8T drive sprockets, stress proof steel shaft carried on ball bearings

SPINNER AND CHUTE

- 3/16" steel 20" diameter spinner disc mounted directly on Char-Lynn hydraulic motor shaft
- Six-steel angle iron vanes bolted to disc
- Three-piece chute constructed of #10 gauge minimum material, bolted for easy replacement
- Two-spring loaded baffles to change spread pattern
- Three-steel adjustable external deflectors
- External deflectors overlap at corners
- Baffles and deflectors adjust, and spinner removal are done without use of tools

OPTIONS

- Sectional hinged screen group • Hinged inverted vee • Light group
- Gravity chain oiler • Urethane spinner disc • Dump body mount group
- Chassis mount group • Tailgate latch • Grease tubes to top or rear
- Adjustable height bumper group • Full-length catwalks • Slope fronts
- Access ladder • Bolt-in floor plate • 409 stainless steel • 304 stainless steel • Wetting systems – hydraulic or electric • Special sizes • 18HP Kohler engine drive group • Special color

HOPPER CONSTRUCTION

- 45° Hopper side slope
- #10 gauge steel sides and ends – channel formed at top and continuous welded inside seam
- #10 gauge steel flanged body supports – three minimum per side
- #7 gauge top gusset inside the hopper opposite each side support, extending from top edge down minimum 8" below 45° tapered side
- Material feed gate is adjustable with self-locking screw jack and opening is 10" high x 19" wide
- Lift loops are provided at each corner for easy handling of empty spreader

CONVEYOR

- #7 gauge steel conveyor side rails and floor plate
- Overall width 24" and overall height 9-1/2"
- Sides bolted to conveyor flange
- Chain wiper provided at rear
- 2-1/4" pitch pintle chain (42,000# ultimate) with 3/8" x 1-1/2" cross bars spaced 4-1/2 on center (every other link)
- Chain shields for drag chain are bolt-on style
- Chain tensioned by spring loaded idler – minimum 3" of adjustment
- Idler roller supported on ball bearings

CONVEYOR DRIVE

- Char-Lynn hydraulic motor coupled to input shaft drives gearbox
- 50:1 worm gearbox speed reducer
- Worm gear is aluminum/bronze alloy with 90,000# tensile strength
- Worm is ground, hardened steel
- Drive assembly coupled to 1-1/2" stub output shaft: shaft is stress proof steel carried by tapered roller bearings
- 3" O.D. drive tube with (2)-six tooth drive sprockets

SPINNER AND CHUTE

- 3/16" steel 20" diameter spinner disc mounted directly on Char-Lynn hydraulic motor shaft
- Six-steel angle iron vanes bolted to disc
- Three-piece chute constructed of #10 gauge minimum material, bolted for easy replacement
- Two-spring loaded baffles to change spread pattern
- Three-steel adjustable external deflectors
- External deflectors overlap at corners
- Baffles and deflectors adjust, and spinner removal are done without use of tools

OPTIONS

- Sectional hinged screen group • Hinged inverted vee • Light group • Gravity chain oiler • Urethane spinner disc • Dump body mount group • Chassis mount group
- Tailgate latch • Grease tubes to top or rear • Adjustable height bumper group
- Full-length catwalks • Slope fronts • Access ladder • Bolt-in floor plate • 409 stainless steel • 304 stainless steel • Wetting systems – hydraulic or electric • Special sizes • 18HP Kohler engine drive group • Special color

Dimensional Chart

Length	Width	Height	Overall Length	Capacity	Approx. Weight
8'	84"	51"	118"	5.1 Cu. Yd.	1850
9'	84"	51"	130"	5.8 Cu. Yd.	1925
10'	84"	51"	142"	6.4 Cu. Yd.	2000
11'	84"	51"	154"	7.0 Cu. Yd.	2100
12'	84"	51"	166"	7.7 Cu. Yd.	2190
13'	84"	51"	178"	8.3 Cu. Yd.	2280
14'	84"	51"	190"	8.9 Cu. Yd.	2330

Dimensional Chart

Length	Width	Height	Overall Length	Capacity	Approx. Weight
8'	84"	49 1/2"	118"	5.1 Cu. Yd.	1800
9'	84"	49 1/2"	130"	5.8 Cu. Yd.	1875
10'	84"	49 1/2"	142"	6.4 Cu. Yd.	1950
11'	84"	49 1/2"	154"	7.0 Cu. Yd.	2050
12'	84"	49 1/2"	166"	7.7 Cu. Yd.	2140
13'	84"	49 1/2"	178"	8.3 Cu. Yd.	2230
14'	84"	49 1/2"	190"	8.9 Cu. Yd.	2300

LMC5

LMC5H

Rev. 1.0

State of West Virginia

VENDOR PREFERENCE CERTIFICATE

Certification and application* is hereby made for Preference in accordance with West Virginia Code, §5A-3-37. (Does not apply to construction contracts). West Virginia Code, §5A-3-37, provides an opportunity for qualifying vendors to request (at the time of bid) preference for their residency status. Such preference is an evaluation method only and will be applied only to the cost bid in accordance with the West Virginia Code. This certificate for application is to be used to request such preference. The Purchasing Division will make the determination of the Resident Vendor Preference, if applicable.

- 1. Application is made for 2.5% resident vendor preference for the reason checked: Bidder is an individual resident vendor and has resided continuously in West Virginia for four (4) years immediately preceding the date of this certification; or, Bidder is a partnership, association or corporation resident vendor and has maintained its headquarters or principal place of business continuously in West Virginia for four (4) years immediately preceding the date of this certification; or 80% of the ownership interest of Bidder is held by another individual, partnership, association or corporation resident vendor who has maintained its headquarters or principal place of business continuously in West Virginia for four (4) years immediately preceding the date of this certification; or, Bidder is a nonresident vendor which has an affiliate or subsidiary which employs a minimum of one hundred state residents and which has maintained its headquarters or principal place of business within West Virginia continuously for the four (4) years immediately preceding the date of this certification; or,
2. Application is made for 2.5% resident vendor preference for the reason checked: Bidder is a resident vendor who certifies that, during the life of the contract, on average at least 75% of the employees working on the project being bid are residents of West Virginia who have resided in the state continuously for the two years immediately preceding submission of this bid; or,
3. Application is made for 2.5% resident vendor preference for the reason checked: Bidder is a nonresident vendor employing a minimum of one hundred state residents or is a nonresident vendor with an affiliate or subsidiary which maintains its headquarters or principal place of business within West Virginia employing a minimum of one hundred state residents who certifies that, during the life of the contract, on average at least 75% of the employees or Bidder's affiliate's or subsidiary's employees are residents of West Virginia who have resided in the state continuously for the two years immediately preceding submission of this bid; or,
4. Application is made for 5% resident vendor preference for the reason checked: Bidder meets either the requirement of both subdivisions (1) and (2) or subdivision (1) and (3) as stated above; or,
5. Application is made for 3.5% resident vendor preference who is a veteran for the reason checked: Bidder is an individual resident vendor who is a veteran of the United States armed forces, the reserves or the National Guard and has resided in West Virginia continuously for the four years immediately preceding the date on which the bid is submitted; or,
6. Application is made for 3.5% resident vendor preference who is a veteran for the reason checked: Bidder is a resident vendor who is a veteran of the United States armed forces, the reserves or the National Guard, if, for purposes of producing or distributing the commodities or completing the project which is the subject of the vendor's bid and continuously over the entire term of the project, on average at least seventy-five percent of the vendor's employees are residents of West Virginia who have resided in the state continuously for the two immediately preceding years.

Bidder understands if the Secretary of Revenue determines that a Bidder receiving preference has failed to continue to meet the requirements for such preference, the Secretary may order the Director of Purchasing to: (a) reject the bid; or (b) assess a penalty against such Bidder in an amount not to exceed 5% of the bid amount and that such penalty will be paid to the contracting agency or deducted from any unpaid balance on the contract or purchase order.

By submission of this certificate, Bidder agrees to disclose any reasonably requested information to the Purchasing Division and authorizes the Department of Revenue to disclose to the Director of Purchasing appropriate information verifying that Bidder has paid the required business taxes, provided that such information does not contain the amounts of taxes paid nor any other information deemed by the Tax Commissioner to be confidential.

Under penalty of law for false swearing (West Virginia Code, §61-5-3), Bidder hereby certifies that this certificate is true and accurate in all respects; and that if a contract is issued to Bidder and if anything contained within this certificate changes during the term of the contract, Bidder will notify the Purchasing Division in writing immediately.

Bidder: ROPE, INC. Signed: Benjamin Hoover
Date: 2-23-11 Title: SACES COORDINATOR

*Check any combination of preference consideration(s) indicated above, which you are entitled to receive.

RFQ No. 7011EC15

STATE OF WEST VIRGINIA
Purchasing Division

PURCHASING AFFIDAVIT

West Virginia Code §5A-3-10a states: No contract or renewal of any contract may be awarded by the state or any of its political subdivisions to any vendor or prospective vendor when the vendor or prospective vendor or a related party to the vendor or prospective vendor is a debtor and the debt owed is an amount greater than one thousand dollars in the aggregate.

DEFINITIONS:

"Debt" means any assessment, premium, penalty, fine, tax or other amount of money owed to the state or any of its political subdivisions because of a judgment, fine, permit violation, license assessment, defaulted workers' compensation premium, penalty or other assessment presently delinquent or due and required to be paid to the state or any of its political subdivisions, including any interest or additional penalties accrued thereon.

"Debtor" means any individual, corporation, partnership, association, limited liability company or any other form or business association owing a debt to the state or any of its political subdivisions. "Political subdivision" means any county commission; municipality; county board of education; any instrumentality established by a county or municipality; any separate corporation or instrumentality established by one or more counties or municipalities, as permitted by law; or any public body charged by law with the performance of a government function or whose jurisdiction is coextensive with one or more counties or municipalities. "Related party" means a party, whether an individual, corporation, partnership, association, limited liability company or any other form or business association or other entity whatsoever, related to any vendor by blood, marriage, ownership or contract through which the party has a relationship of ownership or other interest with the vendor so that the party will actually or by effect receive or control a portion of the benefit, profit or other consideration from performance of a vendor contract with the party receiving an amount that meets or exceeds five percent of the total contract amount.

EXCEPTION: The prohibition of this section does not apply where a vendor has contested any tax administered pursuant to chapter eleven of this code, workers' compensation premium, permit fee or environmental fee or assessment and the matter has not become final or where the vendor has entered into a payment plan or agreement and the vendor is not in default of any of the provisions of such plan or agreement.

Under penalty of law for false swearing (**West Virginia Code §61-5-3**), it is hereby certified that the vendor affirms and acknowledges the information in this affidavit and is in compliance with the requirements as stated.

WITNESS THE FOLLOWING SIGNATURE

Vendor's Name: ROPE, INC.

Authorized Signature: *Benjamin Horse* Date: 2-23-11

State of West Virginia

County of Kaneva, to-wit:

Taken, subscribed, and sworn to before me this 23 day of February, 2011.

My Commission expires 4-20, 2020.

AFFIX SEAL HERE

NOTARY PUBLIC

James Wallace Rollins

