



State of West Virginia
 Department of Administration
 Purchasing Division
 2019 Washington Street East
 Post Office Box 50130
 Charleston, WV 25305-0130

Request for Quotation

RFQ NUMBER
7011EC14

PAGE
1

ADDRESS CORRESPONDENCE TO ATTENTION OF:
BUYER 33 304-558-2402

VENDOR

*709043751 304-366-4690
 MIDDLETOWN TRACTOR SALES
 2345 WHITEHALL BLVD
 FAIRMONT WV 26554

SHIP TO

DIVISION OF HIGHWAYS
 EQUIPMENT DIVISION
 ROUTE 33
 BRUSHY FORK ROAD
 BUCKHANNON, WV
 26201 304-472-1750

DATE PRINTED	TERMS OF SALE	SHIP VIA	F.O.B.	FREIGHT TERMS
12/29/2010	NET30	Truck	Destination	Prepaid

BID OPENING DATE: **02/23/2011** BID OPENING TIME: **01:30PM**

LINE	QUANTITY	UOP	CAT NO	ITEM NUMBER	UNIT PRICE	AMOUNT
0001	1	LB		570-64	\$ 9984.00	\$9984.00
<p>TO PROVIDE 5 CUBIC YARD STAINLESS STEEL,</p> <p>MONroe MSV-108-84-50-WV, 08,304,12/10, 50:1, 1.5DR</p> <p>REQUEST FOR QUOTATION (RFQ) OPEN END CONTRACT</p> <p>THE WEST VIRGINIA STATE PURCHASING DIVISION FOR THE AGENCY, THE WEST VIRGINIA DIVISION OF HIGHWAYS, IS SOLICITING BIDS FOR AN OPEN END CONTRACT TO PROVIDE A 5 CUBIC YARD STAINLESS STEEL DEMOUNTABLE ABRASIVE AND CHEMICAL SPREADER HYDRAULIC PER THE ATTACHED SPECIFICATIONS.</p> <p>TECHNICAL QUESTIONS CONCERNING THIS SOLICITATION MUST BE SUBMITTED IN WRITING TO SHERI SLONE IN THE WEST VIRGINIA STATE PURCHASING DIVISION VIA MAIL AT THE ADDRESS SHOWN IN THE BODY OF THIS RFQ, VIA FAX AT 304-558-2596, OR VIA EMAIL AT SHERI.D.SLONE@WV.GOV. DEADLINE FOR ALL TECHNICAL QUESTIONS IS 01/19/2011 AT THE CLOSE OF BUSINESS. ANY TECHNICAL QUESTIONS RECEIVED WILL BE ANSWERED BY FORMAL ADDENDUM TO BE ISSUED BY THE PURCHASING DIVISION AFTER THE DEADLINE HAS LAPSED.</p> <p>MANDATORY PRE-BID</p> <p>A MANDATORY PRE-BID WILL BE HELD ON TUESDAY, 02/01/2011 AT 10 AM IN BRUSHY FORK RD IN BUCKHANNON, WV 26201. ALL INTERESTED PARTIES ARE REQUIRED TO ATTEND THIS MEETING</p>						

RECEIVED
 2011 FEB 23 A 10:28
 PURCHASING DIVISION
 STATE OF WV

SEE REVERSE SIDE FOR TERMS AND CONDITIONS			
SIGNATURE	TELEPHONE	DATE	
<i>[Signature]</i>	304 366 3690	02-22-11	
TITLE	FEIN	ADDRESS CHANGES TO BE NOTED ABOVE	
Aftermarket Manager	550547175		

WHEN RESPONDING TO RFQ, INSERT NAME AND ADDRESS IN SPACE ABOVE LABELED 'VENDOR'



State of West Virginia
 Department of Administration
 Purchasing Division
 2019 Washington Street East
 Post Office Box 50130
 Charleston, WV 25305-0130

Request for Quotation

RFQ NUMBER
7011EC14

PAGE
2

ADDRESS CORRESPONDENCE TO ATTENTION OF:
BUYER 33 304-558-2402

PRIORITY

*709043751 304-366-4690
 MIDDLETOWN TRACTOR SALES
 2345 WHITEHALL BLVD
 FAIRMONT WV 26554

SHIP TO

DIVISION OF HIGHWAYS
 EQUIPMENT DIVISION
 ROUTE 33
 BRUSHY FORK ROAD
 BUCKHANNON, WV
 26201 304-472-1750

DATE PRINTED	TERMS OF SALE	SHIP VIA	F.O.B.	FREIGHT TERMS
12/29/2010	NET30	Truck	Destination	Prepaid
BID OPENING DATE: 02/23/2011		BID OPENING TIME 01:30PM		

LINE	QUANTITY	UOP	CAT NO	ITEM NUMBER	UNIT PRICE	AMOUNT
<p>FAILURE TO ATTEND THE MANDATORY PRE-BID SHALL RESULT IN DISQUALIFICATION OF THE BID. NO ONE PERSON MAY REPRESENT MORE THAN ONE BIDDER.</p> <p>AN ATTENDANCE SHEET WILL BE MADE AVAILABLE FOR ALL POTENTIAL BIDDERS TO COMPLETE. THIS WILL SERVE AS THE OFFICIAL DOCUMENT VERIFYING ATTENDANCE AT THE MANDATORY PRE-BID. FAILURE TO PROVIDE YOUR COMPANY AND REPRESENTATIVE NAME ON THE ATTENDANCE SHEET WILL RESULT IN DISQUALIFICATION OF THE BID. THE STATE WILL NOT ACCEPT ANY OTHER DOCUMENTATION TO VERIFY ATTENDANCE. THE BIDDER IS RESPONSIBLE FOR ENSURING THEY HAVE COMPLETED THE INFORMATION REQUIRED ON THE ATTENDANCE SHEET. THE PURCHASING DIVISION AND THE STATE AGENCY WILL NOT ASSUME ANY RESPONSIBILITY FOR A BIDDER-S FAILURE TO COMPLETE THE PRE-BID ATTENDANCE SHEET. IN ADDITION, WE REQUEST THAT ALL POTENTIAL BIDDERS INCLUDE THEIR E-MAIL ADDRESS AND FAX NUMBER.</p> <p>ALL POTENTIAL BIDDERS ARE REQUESTED TO ARRIVE PRIOR TO THE STARTING TIME FOR THE PRE-BID. BIDDERS WHO ARRIVE LATE, BUT PRIOR TO THE DISMISSAL OF THE TECHNICAL PORTION OF THE PRE-BID WILL BE PERMITTED TO SIGN IN. BIDDERS WHO ARRIVE AFTER CONCLUSION OF THE TECHNICAL PORTION OF THE PRE-BID, BUT DURING ANY SUBSEQUENT PART OF THE PRE-BID WILL NOT BE PERMITTED TO SIGN THE ATTENDANCE SHEET.</p> <p>EXHIBIT 10</p> <p style="text-align: right;">REQUISITION NO.: 7011EC14.....</p> <p>ADDENDUM ACKNOWLEDGEMENT</p> <p>I HEREBY ACKNOWLEDGE RECEIPT OF THE FOLLOWING CHECKED</p>						

SEE REVERSE SIDE FOR TERMS AND CONDITIONS			
SIGNATURE	TELEPHONE	DATE	
<i>3 Mark</i>	304 366 4690	02-22-11	
TITLE	FEIN	ADDRESS CHANGES TO BE NOTED ABOVE	
Aftermarket Manager	550547175		

WHEN RESPONDING TO RFQ, INSERT NAME AND ADDRESS IN SPACE ABOVE LABELED 'VENDOR'



State of West Virginia
 Department of Administration
 Purchasing Division
 2019 Washington Street East
 Post Office Box 50130
 Charleston, WV 25305-0130

Request for Quotation

RFQ NUMBER
7011EC14

PAGE
3

ADDRESS CORRESPONDENCE TO ATTENTION OF:
BUYER 33
304-558-2402

VENDOR

*709043751 304-366-4690
MIDDLETOWN TRACTOR SALES
2345 WHITEHALL BLVD

FAIRMONT WV 26554

SHIP TO

DIVISION OF HIGHWAYS
EQUIPMENT DIVISION
ROUTE 33
BRUSHY FORK ROAD
BUCKHANNON, WV
26201 **304-472-1750**

DATE PRINTED 12/29/2010	TERMS OF SALE NET30	SHIP VIA Truck	F.O.B. Destination	FREIGHT TERMS Prepaid
-----------------------------------	-------------------------------	--------------------------	------------------------------	---------------------------------

BID OPENING DATE: **02/23/2011** BID OPENING TIME **01:30PM**

LINE	QUANTITY	UOP	CAT NO	ITEM NUMBER	UNIT PRICE	AMOUNT
<p>ADDENDUM(S) AND HAVE MADE THE NECESSARY REVISIONS TO MY PROPOSAL, PLANS AND/OR SPECIFICATION, ETC.</p> <p>ADDENDUM NO.'S:</p> <p>NO. 1 <input checked="" type="checkbox"/></p> <p>NO. 2</p> <p>NO. 3</p> <p>NO. 4</p> <p>NO. 5</p> <p>I UNDERSTAND THAT FAILURE TO CONFIRM THE RECEIPT OF THE ADDENDUM(S) MAY BE CAUSE FOR REJECTION OF BIDS.</p> <p>VENDOR MUST CLEARLY UNDERSTAND THAT ANY VERBAL REPRESENTATION MADE OR ASSUMED TO BE MADE DURING ANY ORAL DISCUSSION HELD BETWEEN VENDOR'S REPRESENTATIVES AND ANY STATE PERSONNEL IS NOT BINDING. ONLY THE INFORMATION ISSUED IN WRITING AND ADDED TO THE SPECIFICATIONS BY AN OFFICIAL ADDENDUM IS BINDING.</p> <p>..... SIGNATURE Middletown Tractor Sales COMPANY 02-22-11 DATE</p>						

SEE REVERSE SIDE FOR TERMS AND CONDITIONS

SIGNATURE <i>3 Mark</i>	TELEPHONE 304 366-4690	DATE 02-22-11
TITLE Aftermarket Mgr.	FEIN 550547175	ADDRESS CHANGES TO BE NOTED ABOVE

WHEN RESPONDING TO RFQ, INSERT NAME AND ADDRESS IN SPACE ABOVE LABELED 'VENDOR'



State of West Virginia
 Department of Administration
 Purchasing Division
 2019 Washington Street East
 Post Office Box 50130
 Charleston, WV 25305-0130

Request for Quotation

RFQ NUMBER
7011EC14

PAGE
4

ADDRESS CORRESPONDENCE TO ATTENTION OF:
**BUYER 33
 304-558-2402**

VENDOR

*709043751 304-366-4690
**MIDDLETOWN TRACTOR SALES
 2345 WHITEHALL BLVD
 FAIRMONT WV 26554**

SHIP TO

**DIVISION OF HIGHWAYS
 EQUIPMENT DIVISION
 ROUTE 33
 BRUSHY FORK ROAD
 BUCKHANNON, WV
 26201 304-472-1750**

DATE PRINTED 12/29/2010	TERMS OF SALE NET30	SHIP VIA Truck	F.O.B. Destination	FREIGHT TERMS Prepaid
BID OPENING DATE: 02/23/2011		BID OPENING TIME 01:30PM		

LINE	QUANTITY	UOP	CAT NO	ITEM NUMBER	UNIT PRICE	AMOUNT
<p>NOTE: THIS ADDENDUM ACKNOWLEDGEMENT SHOULD BE SUBMITTED WITH THE BID.</p> <p>REV. 09/21/2009</p> <p>EXHIBIT 2</p> <p>LIFE OF CONTRACT: THIS CONTRACT BECOMES EFFECTIVE ON AND EXTENDS FOR A PERIOD OF ONE (1) YEAR OR UNTIL SUCH "REASONABLE TIME" THEREAFTER AS IS NECESSARY TO OBTAIN A NEW CONTRACT OR RENEW THE ORIGINAL CONTRACT. THE "REASONABLE TIME" PERIOD SHALL NOT EXCEED TWELVE (12) MONTHS. DURING THIS "REASONABLE TIME" THE VENDOR MAY TERMINATE THIS CONTRACT FOR ANY REASON UPON GIVING THE DIRECTOR OF PURCHASING THIRTY (30) DAYS WRITTEN NOTICE.</p> <p>UNLESS SPECIFIC PROVISIONS ARE STIPULATED IN THIS CONTRACT DOCUMENT, THE TERMS, CONDITIONS, AND PRICING SET HEREIN ARE FIRM FOR THE LIFE OF THE CONTRACT.</p> <p>RENEWAL: THIS CONTRACT MAY BE RENEWED UPON THE MUTUAL WRITTEN CONSENT OF THE SPENDING UNIT AND VENDOR, SUBMITTED TO THE DIRECTOR OF PURCHASING THIRTY (30) DAYS PRIOR TO THE EXPIRATION DATE. SUCH RENEWAL SHALL BE IN ACCORDANCE WITH THE TERMS AND CONDITIONS OF THE ORIGINAL CONTRACT AND SHALL BE LIMITED TO TWO (2) ONE (1) YEAR PERIODS.</p> <p>CANCELLATION: THE DIRECTOR OF PURCHASING RESERVES THE RIGHT TO CANCEL THIS CONTRACT IMMEDIATELY UPON WRITTEN NOTICE TO THE VENDOR IF THE COMMODITIES AND/OR SERVICES SUPPLIED ARE OF AN INFERIOR QUALITY OR DO NOT CONFORM WITH THE SPECIFICATIONS OF THE BID AND CONTRACT HEREIN.</p>						

SEE REVERSE SIDE FOR TERMS AND CONDITIONS

SIGNATURE <i>[Signature]</i>	TELEPHONE 304-366-4690	DATE 02-22-2011
TITLE Aftermarket Ngr.	FEIN 550547175	ADDRESS CHANGES TO BE NOTED ABOVE

WHEN RESPONDING TO RFQ, INSERT NAME AND ADDRESS IN SPACE ABOVE LABELED 'VENDOR'



State of West Virginia
 Department of Administration
 Purchasing Division
 2019 Washington Street East
 Post Office Box 50130
 Charleston, WV 25305-0130

Request for Quotation

RFQ NUMBER
7011EC14

PAGE
5

ADDRESS CORRESPONDENCE TO ATTENTION OF:
BUYER 33 304-558-2402

*709043751 304-366-4690
 MIDDLETOWN TRACTOR SALES
 2345 WHITEHALL BLVD
 FAIRMONT WV 26554

VENDOR

DIVISION OF HIGHWAYS
 EQUIPMENT DIVISION
 ROUTE 33
 BRUSHY FORK ROAD
 BUCKHANNON, WV
 26201 304-472-1750

SHIP TO

DATE PRINTED	TERMS OF SALE	SHIP VIA	F.O.B.	FREIGHT TERMS
12/29/2010	NET30	Truck	Destination	Prepaid
BID OPENING DATE: 02/23/2011		BID OPENING TIME 01:30PM		

LINE	QUANTITY	UOP	CAT NO	ITEM NUMBER	UNIT PRICE	AMOUNT
<p>OPEN MARKET CLAUSE: THE DIRECTOR OF PURCHASING MAY AUTHORIZE A SPENDING UNIT TO PURCHASE ON THE OPEN MARKET, WITHOUT THE FILING OF A REQUISITION OR COST ESTIMATE, ITEMS SPECIFIED ON THIS CONTRACT FOR IMMEDIATE DELIVERY IN EMERGENCIES DUE TO UNFORESEEN CAUSES (INCLUDING BUT NOT LIMITED TO DELAYS IN TRANSPORTATION OR AN UNANTICIPATED INCREASE IN THE VOLUME OF WORK).</p> <p>QUANTITIES: QUANTITIES LISTED IN THE REQUISITION ARE APPROXIMATIONS ONLY, BASED ON ESTIMATES SUPPLIES BY THE STATE SPENDING UNIT. IT IS UNDERSTOOD AND AGREED THAT THE CONTRACT SHALL COVER THE QUANTITIES ACTUALLY ORDERED FOR DELIVERY DURING THE TERM OF CONTRACT, WHETHER MORE OR LESS THAN THE QUANTITIES SHOWN.</p> <p>ORDERING PROCEDURE: SPENDING UNIT(S) SHALL ISSUE A WRITTEN EQUIPMENT CONTRACT ORDER (FORM NUMBER WV-35) FOR COMMODITIES COVERED BY THIS CONTRACT. THE ORIGINAL WV-35 MUST BE SENT TO THE PURCHASING DIVISION OF THE DEPARTMENT OF ADMINISTRATION. AFTER APPROVAL AND ENCUMBRANCE, ONE COPY OF THE PURCHASE ORDER WILL BE RETURNED TO THE SPENDING UNIT AND ONE COPY FORWARDED TO THE VENDOR AS AUTHORIZATION FOR SHIPMENT. NO ORDER IS VALID UNLESS APPROVED AND ENCUMBERED BY THE PURCHASING DIVISION.</p> <p>BANKRUPTCY: IN THE EVENT THE VENDOR/CONTRACTOR FILES FOR BANKRUPTCY PROTECTION, THE STATE MAY DEEM THE CONTRACT NULL AND VOID, AND TERMINATE SUCH CONTRACT WITHOUT FUTHER ORDER.</p> <p>REV. 5/2009</p> <p>EXHIBIT 4</p>						

SEE REVERSE SIDE FOR TERMS AND CONDITIONS

SIGNATURE	TELEPHONE	DATE
<i>3 M...</i>	304-366-4690	02-22-2011
TITLE	FEIN	ADDRESS CHANGES TO BE NOTED ABOVE
Aftermarket Mgr.	550547175	

WHEN RESPONDING TO RFQ, INSERT NAME AND ADDRESS IN SPACE ABOVE LABELED 'VENDOR'



State of West Virginia
 Department of Administration
 Purchasing Division
 2019 Washington Street East
 Post Office Box 50130
 Charleston, WV 25305-0130

Request for Quotation

RFQ NUMBER
7011EC14

PAGE
7

ADDRESS CORRESPONDENCE TO ATTENTION OF
BUYER 33 304-558-2402

VENDOR	*709043751 304-366-4690
	MIDDLETOWN TRACTOR SALES 2345 WHITEHALL BLVD
	FAIRMONT WV 26554

SHIP TO	DIVISION OF HIGHWAYS EQUIPMENT DIVISION ROUTE 33 BRUSHY FORK ROAD BUCKHANNON, WV 26201 304-472-1750
---------	---

DATE PRINTED	TERMS OF SALE	SHIP VIA	F.O.B.	FREIGHT TERMS
12/29/2010	NET30	Truck	Destination	Prepaid
BID OPENING DATE: 02/23/2011		BID OPENING TIME 01:30PM		

LINE	QUANTITY	UOP	CAT NO.	ITEM NUMBER	UNIT PRICE	AMOUNT
				RFQ. NO.: 7011EC14		
				BID OPENING DATE: 02/23/2011		
				BID OPENING TIME: 1:30 PM		
				PLEASE PROVIDE A FAX NUMBER IN CASE IT IS NECESSARY TO CONTACT YOU REGARDING YOUR BID: 304-366-4698		
				CONTACT PERSON (PLEASE PRINT CLEARLY): Zach Marsh		
				***** THIS IS THE END OF RFQ 7011EC14 ***** TOTAL:		\$9984.00

SEE REVERSE SIDE FOR TERMS AND CONDITIONS

SIGNATURE	TELEPHONE	DATE
	304-366-4690	02-22-2011
TITLE	FEIN	ADDRESS CHANGES TO BE NOTED ABOVE
Aftermarket Mgr.	550547175	

WHEN RESPONDING TO RFQ, INSERT NAME AND ADDRESS IN SPACE ABOVE LABELED 'VENDOR'

WEST VIRGINIA DEPARTMENT OF TRANSPORTATION
DIVISION OF HIGHWAYS
EQUIPMENT DIVISION

BIDDER'S EVALUATION REPORT

PROCUREMENT SPECIFICATIONS FOR OPEN END CONTRACT
NO. 012-2-A

OPEN END CONTRACT
FIVE CUBIC YARD STAINLESS STEEL DEMOUNTABLE ABRASIVE
AND CHEMICAL SPREADER (HYDRAULIC)

NOTE TO BIDDER: Procurement Specification No. 012-2-A, Paragraph 2.0 recommends the completion and submittal of this Report with your bid. Purpose of this Report is to enable the West Virginia Division of Highways Evaluation Committee to make full and fair evaluation of the bid. Addendums in order, along with a summary of exception as a separate attachment, should be with Bidder's Evaluation Report. FAILURE TO SUBMIT THIS REPORT, COMPLETE IN ITS ENTIRETY, MAY SUBJECT THE BIDDER TO DISQUALIFICATION.

Reference Requisition No.: 7011EC14

Bidder's Name: Middletown Tractor Sales

Address: 2345 Whitehall Blvd. Fairmont, WV 26554

Telephone Number: 304-366-4690

Years Bidder has been registered to do business with the State of West Virginia: 25 YRS.

Years Company has been an authorized dealer for proposed unit: 4 YRS.

X3.2 Have you complied with all mandatory specifications? YES NO

X4.2 DELIVERY:

X4.2.1 Delivery date of completed representative unit: 45 Calendar Days After
Receipt of Purchase Agreement

X4.2.2 Delivery date of balance of completed units: 135 Calendar Days After Receipt of
Purchase Agreement

X5.0 AWARD CRITERIA;

X5.1 Price per unit:

\$9984.00 per unit

X6.0 SPECIFICATIONS - GENERAL

X6.1 Manufacturer, model, series, and date of manufacture of proposed unit:

Monroe Model: MSV-108-84-50-WV, 08, 304, 12/10, 50:1, 1.5DR Manufacture February 2011 or later

Is descriptive literature, fully describing proposed unit attached to your bid? YES NO

If not, why? _____

X6.2 Will the required number of service manuals, and complete parts list be delivered to the Equipment Division at Buckhannon upon completion of delivery of total units?

YES NO

Will the required Equipment Preventive Maintenance Form (Section X6.2 of Bidders Evaluation Report) be provided upon inspection of the pilot unit?

YES NO

X6.3 TRAINING:

Will training seminar be conducted on Preventive Maintenance, Operator and Mechanic Training
 YES NO

Will you conduct training with each purchase order against this open end contract?
 YES NO

Will training be conducted within 2 working days from the delivery of the pilot unit on the individual purchase order?
 YES NO

If NO, explain time frame _____

Will an Operator's Manual be furnished directly to Training Academy prior to the delivery of the pilot?
 YES NO

X6.4 If you are the successful vendor, will you furnish all training aids, i.e., videos, projectors, required in conducting the training?
 YES NO

X6.4.1 Will all manuals, booklets, etc. explaining preventive maintenance, operator procedures, and service schedule be delivered with each unit?
 YES NO
 If NO, explain _____

X6.5 WARRANTY AND SERVICE POLICY

Will the warranty and service you provide comply with all areas as stated in Section 6.5 of specifications
 YES NO

Is warranty literature attached?
 YES NO

Is a minimum two (2) year bumper to bumper basic parts and labor warranty excluding abuse and normal wear items included?
 YES NO

Describe:

_____ A 2 year warranty covering defects in parts or workmanship applies

to this product as described in the attached warranty statement

_____ provided by the manufacturer. See the attached warranty statement.

X6.5 WARRANTY AND SERVICE POLICY QUESTIONNAIRE

THIS FORM MUST BE COMPLETED IN ITS ENTIRETY AND SUBMITTED WITH YOUR BID.

(If additional lines are needed, make copies of form.)

1. Define the terms of the standard warranty. If not offered, so state. (Attach copy)

This machinery is covered by a two year warranty against defects in the parts or workmanship of the product. See the attached warranty statement from the manufacturer.

2. Define warranty service to be performed at DOH facilities and warranty service to be performed at manufacturer's representative facility. List name and location of manufacturer's representative.

Warranty repairs are to be handled by Middletown Tractor Sales of Fairmont West Virginia.

3. List locations for parts inventories that are within the State of West Virginia. Also, list availability levels, if known.

Parts inventories are located at Middletown Tractor Sales Fairmont West Virginia.

Approximately 30 line items in varying quantities are stocked based on seasonality.

4. During the term of warranty, list the guarantee discount to manufacturer's published list price for parts that bidder will sell the parts to owner.

- A. Terms: Net 30 Manufacturer's published list price less: 5.0 % discount
- B. Terms: Net 60 Manufacturer's published list price less: 5.0 % discount
- C. Terms: Net 90 Manufacturer's published list price less: 5.0 % discount

5. During the term of warranty, will all manufacturers or engineering improvements be submitted to Division of Highways? X YES NO

6. During the term of warranty, list the guaranteed rates charged for repair to the unit.

A. Shop Rate \$ 65.00 per mechanic hour

B. Travel Time Charge \$ 70.00 per mechanic hour
(Specify if one-way) _____ ; port to port \$70.00

C. Mileage Charge \$ n/a per vehicle mile
(Specify if one-way) n/a ; port to port n/a

D. Field Mechanic Rate \$ 70.00 per mechanic hour

E. Specify period of time that prices are in effect: For the life of this contract we will honor this service pricing.

F. Surcharge for miscellaneous items: 6.0 % fuel surcharge added to hourly travel charge.

X6.6 EVALUATION COMMITTEE REQUIREMENTS

Is all component specifications, product literature, component models provided for Evaluation Committee bid determination? YES NO

X6.7 Will all parts, equipment, accessories, material, design and performance characteristics not specified herein, but which are necessary to provide a complete unit, be furnished with the unit and conform in strength, quality of material, and quality of workmanship to those which are advertised and provided to the market in general by the unit industry?

YES NO

X6.7.1 Are all parts and accessories adequate and regularly supplied as standard to be included except those which may be duplications of specifications herein, and except these by specification are not to be furnished?

YES NO

X6.7.2 Are all standard safety features that are required by Federal and State statutes of law included?

YES NO

X7.0 SPECIFICATIONS OF THE QUOTED UNIT

The bidder should complete the following schedule in order for the Division of Highways to compare the actual bid unit to the specifications. Should the bidder except a requirement, then such exception may be only on the basis that such feature is not offered by the manufacturer. The Division will have the sole discretion as to whether the bidder's substitution meets the requirements of the specifications.

Manufacturer: Monroe

Model: MSV-108-84-50-WV, 08, 304, 12/10, 50:1

1.5DR

X7.1 Is spreaders offered the commercial heavy duty, self contained, hopper type? YES NO

X7.2 Does spreader consist of a 12 gauge 304 stainless steel body, feeder conveyor, spinner disc, power drive, and all components necessary to make a complete operating unit? YES NO

X7.3 Is the unit capable of uniformly spreading sand, cinders, salt, calcium chloride, or other mixtures up to a width of forty (40) feet? YES NO

See Addendum No. 1

X7.4 Body:

X7.4.1 Is the body of 304 stainless steel construction 100% welded inside and outside of the body? YES NO

X7.4.2 Capacity struck: 5 CUBIC YARDS See Addendum No. 1

X7.4.3 Inside length: 9 FEET as measured from front of spreader hopper to the rear hopper gate and conveyor chain exit point

- X7.4.4 Overall height: 48 INCHES
- X7.4.5 Inside width: 84 INCHES
- X7.4.6 Are the body sides sloped approximately 45° pitch to insure free flow of materials to the conveyor X YES NO
- X7.4.7 Gauge of 304 stainless steel in sides and endgates is 12 Gauge.
- X7.4.8 Is a formed double crimped section on top of body for additional support? X YES NO
- X7.4.9 Sills constructed of 10 gauge 304 stainless steel.
Supported on rectangular formed cross sills X YES NO
- X7.4.10 Number of 12 gauge full slope body side supports tying the cross sills with body sides? 4 each side
- X7.4.11 Are four (4) 304 stainless steel 5/8 inch round lifting eyes fitted to spreader; inside eye opening designed to allow the passage of an alloy eye grade 80 3/8 inch grab hook with a width dimension of 2 11/16 inch (with top screen down in the rest position on top of spreader X YES NO
two (2) on each side of spreader mounted and secured in such a manner that the entire unit may be safely lifted for storage/installing purposes X YES NO
- X7.4.12 Is all necessary hardware stainless steel X YES NO
- X7.4.13 Is a 12 gauge 304 stainless steel front mounted spill shield provided? X YES NO
Is the spill shield 76 inches wide x 20 inches long and sloped front to rear, in order that loaded material, salt, cinders, etc. will fall into hopper as spreader unloads? X YES NO
- X7.4.13.1 Is a 300 series stainless steel grab handle mounted to the drivers side spill shield side plate at a convenient location to assist operator when climbing atop spreader to remove "chunks or debris"? X YES NO
- X7.4.14 Will a fold up stainless steel ladder be mounted on the rear of spreader body at right for easier access to top? X YES NO
Does the ladder have hand holds, non-slip strut steps, and manufacturers locking mechanism to lock ladder in up position when not in use? X YES NO
- X7.4.14.1 Is a 300 series stainless steel grip strut step plate mounted on rear of spreader "spinner" housing frame, above rear baffle, full width of spinner housing? X YES NO
- X7.4.15 Is a work light mounted on cab shield for night shift visibility of spreader grating with weatherproof wiring? X YES NO

X7.5 Conveyor:

- X7.5.1 Is the conveyor located in bottom of hopper and capable of engaging material along its full length and moving material to rear adjustable metering gate? YES NO
- X7.5.2 Is conveyor continuous ladder type consisting of two parallel chains with cross bars on 4 2" centers made of 1/4" x 1-1/2" steel? YES NO
- X7.5.3 Is each cross bar formed and welded both top and bottom to chain links YES NO
- X7.5.4 Tensile strength of each chain: 21,000 pounds
- X7.5.5 Overall width of chain conveyor: 20 inches
- X7.5.6 Are replaceable rubber wear strips provided to prevent contact of material being spread with the chain? YES NO
- X7.5.7 Is a 10 gauge 304 stainless steel heavy-duty replaceable conveyor plate fitted? YES NO
- X7.5.8 Is the chain drive through 1-1/2" sprockets and shafting front and rear? YES NO
See Addendum No. 1
- X7.5.9 Does conveyor have adjustment provisions at rear of spreader for at least 3" lateral takeup? YES NO
- X7.5.10 Is additional 7 gauge 304 stainless steel reinforcing plate welded to longitudinal webs covering the area of the drive shaft, bearing, and idler bearing provided if required? YES NO
- X7.5.11 Is material composition of adjustment mechanism rust proof? YES NO
- X7.5.12 Is conveyor drive motor mounted on hopper side of reduction gear box? YES NO
See Addendum No. 1
- X7.5.12.1 Does the reduction gear box provide a 50:1 ratio? YES NO
- X7.5.13 Does conveyor gear box motor have an integral speed sensor? YES NO
- X7.5.13.1 Is adequate shielding provided that will cover exposed shaft, coupling, and application rate sensor? YES NO
- X7.5.14 Is a 7 gauge stainless steel adjustable greasable screw jack type discharge gate located at the body rear to adjust the flow of material to the spinner? YES NO
- X7.5.15 Feedgate opening: 12 inches high x 18 inches wide
- X7.5.16 Is any and all exposed moving or rotating mass adequately shielded in order to protect personnel while performing required operational adjustments? YES NO

X7.6 Distributor Spinner Assembly:

X7.6.1 Diameter of urethane distributor disc 20 inches

X7.6.1.1 Number of fins: 6

X7.6.1.2 Are fins designed to obtain a controlled spread of materials from four feet (4') to forty feet (40')? YES NO

X7.6.2 Is material guided from conveyor end to distributor disc by means of an externally adjustable material flow baffles, enclosed within the chute? YES NO

X7.6.3 The spinner is vertically adjustable 18 inches?
and provides a 20-38 inch spinner position below mounting surface?

X7.6.4 Is a deflector baffle or diverter chute provided in an enclosed distributor spinner hopper assembly so it can be positioned in such a manner that material can be unloaded from spreader without striking spinner? YES NO
See Addendum No. 1

X7.7 Baffles:

X7.7.1 Are baffles provided to control direction and width of spread? YES NO

X7.7.1.2 Are there four (4) sections over right, left, rear and front of spinners? YES NO

Is front spinner baffle shield (truck side) stationary? YES NO

X7.7.2 Are sections easily adjusted from the full down to the horizontal position without use of tools? YES NO

X7.8. Power Drive:

X7.8.1 Is the power drive hydraulic type? YES NO

X7.8.1.2 Are two (2) hydraulic motors provided - one (1) powering the spinner assembly and one (1) powering the conveyor? YES NO

X7.8.2 Spinner hydraulic motor mounted below the spinner hopper assembly? YES NO

X7.8.3 The conveyor hydraulic motor of the orbital, low speed, hi-torque integrally mounted to conveyor gear box? YES NO

X7.9 Pintle Conveyor Chain:

X7.9.1 Is the pintle conveyor chain constructed of heat treated formed links with locked, non-turning pins? YES NO

X7.9.2 Specify tensile strength of each conveyor chain strand 21,000 pounds

X7.10 Screen Over Hopper:

X7.10.1 Are four (4) sectional screens hinged to 10 gauge 304 stainless steel 4 inch x 6 inch formed box beam running longitudinally the full length of spreader hopper? YES NO

If not specify: _____

X7.10.2 Do screen sections have 3/8" diameter rods welded to 3/16" - 2:" angle frame forming 2-1/2" x 2-1/2" square openings? YES NO

If not specify: _____

X7.10.3 Do screens increase overall height of spreader more than 7 inches down the center? YES NO

X7.11 Is lighting in accordance with the attached sketch and wiring schematic? YES NO

X7.11.1 Is the combination and marker lights LED type YES NO

X7.11.2 Stop, tail, turn combination lights and marker lights are shielded YES NO

X7.11.3 Strobe light is "quad flash" YES NO

See Addendum No.1 Warning light is Class 1 LED Amber.

X7.12 Hydraulic Components:

X7.12.1 Are all necessary fittings for complete hookup of spreader hydraulics to DOH dump trucks central hydraulic system provided? YES NO

X7.12.2 Are all fittings of the steel type and designed for hydraulic use? YES NO

X7.12.3 Will the hoses mate with the quick disconnects on the central hydraulic system of the truck? YES NO

Will you furnish the male quick disconnects, metal caps, and plugs for connection to truck manifold? YES NO

X7.13 Is an anodized 6061T6 aluminum YES NO

(OR)

304 stainless steel YES NO grease manifold block mounted at the rear of the body which incorporates the front bearing grease extension tubes, rear bearing grease fittings and feedgate screw jack lubrication tube? YES NO

7.13.1 The anodized 6061T6 aluminum YES NO

(OR)

304 stainless steel grease manifold block YES NO has 6 ports tapped to accept three (3) 1/8 inch straight grease zerks and three (3) 1/8 inch grease Parflex hoses to provide for adequate one location greasing of the front and rear bearings and feed gate screw jack? YES NO

Are any unused ports properly plugged YES NO

X7.13.2 Are hoses used in the grease manifold system Parflex hose by Parker Hannifin or equal, with 1/8 inch I.D., 0.34 inch maximum O.D., a maximum working pressure of 2500 psi and a minimum burst pressure of 10,000 psi? YES NO

Are hose assemblies held in place by a sufficient number of rubber cushioned hose clamps? YES NO

X7.14 Is one (1) piece of angle iron 3/8" x 4" X 90" and two (2) pieces of 1" round shafting ten inches (10") long provided but not installed for each unit? YES NO

See Addendum No.1

X7.15 Other standard features:

List other standard features offered but not specifically addressed above:

N/A

X7.16 Paint:

Describe method of painting parts and accessories that are not required to be stainless or rustproof:

Powder Coat. The exceptions to this are the gearboxes and motors which come from the supplier primed and painted with a standard black eurathane paint.

top grates are powder coated.

X7.17 Does unit offered meet or exceed "Occupational Safety and Health Act of 1970"?

YES NO

X7.18 Does unit conform to the advertising guidelines?

YES NO



State of West Virginia
 Department of Administration
 Purchasing Division
 2019 Washington Street East
 Post Office Box 50130
 Charleston, WV 25305-0130

Request for Quotation

RFQ NUMBER
7011EC14

PAGE
1

ADDRESS CORRESPONDENCE TO ATTENTION OF
BUYER 33
304-558-2402

RFQ COPY
 TYPE NAME/ADDRESS HERE

VENDOR

Middletown Tractor Sales
 2345 Whitehall Blvd.
 Fairmont, WV 26554

SHIP TO

DIVISION OF HIGHWAYS
 EQUIPMENT DIVISION
 ROUTE 33
 BRUSHY FORK ROAD
 BUCKHANNON, WV
 26201 **304-472-1750**

DATE PRINTED	TERMS OF SALE	SHIP VIA	FOB	FREIGHT TERMS
02/17/2011	Net30	Truck	Destination	Prepaid

BID OPENING DATE: **02/23/2011** BID OPENING TIME **01:30PM**

LINE	QUANTITY	UOP	CAT NO	ITEM NUMBER	UNIT PRICE	AMOUNT
				ADDENDUM NO. 1		
				THIS ADDENDUM IS ISSUED TO:		
				1.) ADDRESS SPECIFICATION CHANGES PER THE ATTACHED.		
				2.) PROVIDE A COPY OF THE MANDATORY PRE-BID ATTENDEE LIST.		
				*****END ADDENDUM NO. 1*****		
0001		LB		Monroe MSV-108-84-50-WV,08,304,12/10,50:1,1.5DR		
	1			570-64		\$9984.00
				TO PROVIDE 5 CUBIC YARD STAINLESS STEEL,		
				***** THIS IS THE END OF RFQ 7011EC14 ***** TOTAL:		\$9984.00

SEE REVERSE SIDE FOR TERMS AND CONDITIONS

SIGNATURE <i>3 M...</i>	TELEPHONE 304 366 4690	DATE 2-22-11
TITLE Aftermarket Mgr	FEIN 550547175	ADDRESS CHANGES TO BE NOTED ABOVE

WHEN RESPONDING TO RFQ, INSERT NAME AND ADDRESS IN SPACE ABOVE LABELED 'VENDOR'



1051 W. 7th Street • Monroe, WI 53566
800-880-0109 • 608-329-8105 • FAX 608-328-8390
E-mail: snowandicecontrol@monroetruck.com • Website: www.monroetruck.com

MONROE TRUCK EQUIPMENT, INC. WARRANTY SNOW & ICE CONTROL PRODUCTS

STATE OF WEST VIRGINIA

V-BOXES

Monroe Truck Equipment, Inc. warrants to the State of West Virginia, that if any part of the product proves to be defective in workmanship or material with **TWO YEARS** of the original installation, and is returned to us with 30 days of the discovered defect, we will (at our option) repair or replace the defective part. This warranty does not apply to damage resulting from misuse, neglect, accident, improper installation, normal wear items or lack of maintenance. This warranty is exclusive and supersedes all other warranties, whether expressed or implied. **Monroe Truck Equipment, Inc.** neither assumes, nor authorizes anyone to assume for it, any other obligation or liability in connection with this warranty and will not be liable for consequential damages.

All engines, pumps, motors, cylinders and valves are warranted by their manufacturer and not by **Monroe Truck Equipment, Inc.** The manufacturer's warranty will apply to these parts. Electrical and hydraulic components are not to be disassembled without the express written permission of **Monroe Truck Equipment, Inc.** Use of replacement parts other than original equipment voids this warranty.

All defective parts returned must be accompanied by the model number, serial number, date installed, date of defect, description of defect, and the name of the distributor from whom it was purchased. All warranty claims must have prior written approval from **Monroe Truck Equipment, Inc.**

Please return the warranty registration card that accompanies this manual to confirm receipt of this parts catalog and acknowledge the information contained within. Failure to return the attached card may result in a voided warranty.



Reversible & One-way Snowplows • Airport Snowplow • Heavy Duty Patrol Wing
Heavy Duty Benching Wing • Monroe Underbody Scraper • Heavy Duty V-box Spreader
Under Tailgate Spreader • Pickup V-box Spreader • Replacement Tailgate Spreader
Anti-Icing/De-icing & Vegetation Sprayer • Construction Attachments





Monroe Brute

Heavy Duty Model MSV V-Box

Standard Specifications:

- ➡ 10 Gauge Hopper Shell with 45° Sloped Sides
- ➡ 7 Gauge Longitudinals
- ➡ 100% Continuously Welded
- ➡ 4-Bolt Flange Relubeable Bearings
- ➡ Front and Rear Wipers
- ➡ Replaceable Chain Shields
- ➡ 3/8" Bar Flights
- ➡ 3/16" Replaceable Floor
- ➡ 50:1 Worm Drive Gear Box
- ➡ 3/8" Rod, Heavy Duty Top Screens
- ➡ 2" Drive Shaft with 2" Spring Loaded Idler Shaft
- ➡ Screw Adjustable Gate Jack
- ➡ 5/8" Rod Lift Loops
- ➡ Slide Gussets on 24" Centers
- ➡ Tip-Up Adjustable Spinner
- ➡ Lower spinner assembly can be rotated 180° to achieve desired spread pattern.
- ➡ Powder Coated Orange

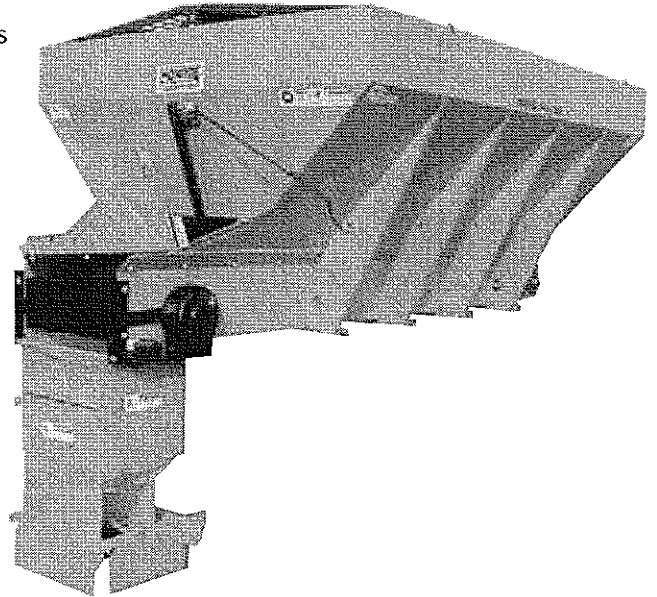

VISIT US ONLINE AT
www.monroetruck.com

Monroe Snow & Ice Control Spreaders Are Designed and Built to Last.

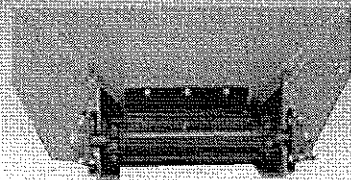

**7 Gauge, Replaceable Chain Shields
10 Gauge Hopper**

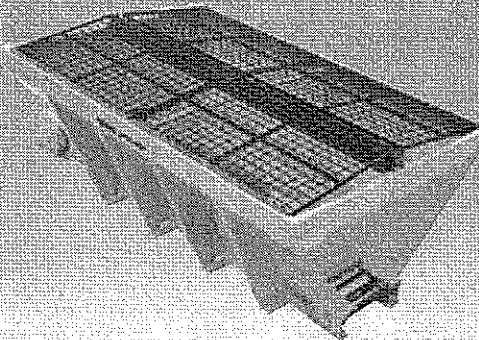

Top Screens

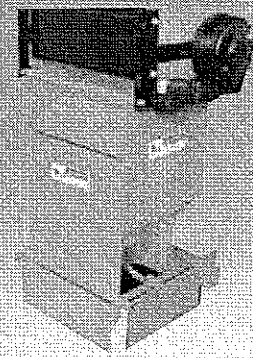

**Standard 10 Gauge Tip-Up
Adjustable Spinner Assembly/Top
Mounted Motor**

PREBID ADDENDUM #1

7011EC14

5 CUBIC YARD STAINLESS STEEL
DEMOUNTABLE ABRASIVE AND CHEMICAL SPREADER (HYDRAULIC)

CHANGES TO SPECIFICATIONS:

FROM:

7.2 Spreaders shall consist of a 12 gauge 304 stainless steel body, feeder conveyor, spinner disc, power drive, and all components necessary to make a complete operating unit.

TO:

7.2 Spreaders shall consist of a 12 gauge minimum 304 stainless steel body, feeder conveyor, spinner disc, power drive, and all components necessary to make a complete operating unit.

FROM:

7.4.2 The struck capacity shall be 5 cubic yards

TO:

7.4.2 The struck capacity shall be within the range of 4.8 – 5.2 cubic yard minimum

FROM:

7.5.8 The chain drive shall be through 1 ½ inch sprockets and shafting front and rear.

TO:

7.5.8 The chain drive shall be through 1 ½ inch minimum sprockets and shafting front and rear.

FROM:

7.5.12 The conveyor drive motor shall be mounted on hopper side of the reduction gear box and have a ratio of approximately 50-1.

TO:

7.5.12 The conveyor drive motor shall be mounted on rear of the reduction gear box and have a ratio of approximately 50-1.

7011EC14

FROM:

7.5.13 Conveyor gear box motor shall have an integral speed.

TO:

7.5.13 Conveyor gear box motor shall have an integral speed sensor

FROM:

7.6.4 A deflector baffle or diverter chute shall be provided in the enclosed distributor spinner hopper assembly so it can be positioned in such a manner that material can be unloaded from spreader without striking spinner.

TO:

7.6.4 A deflector baffle or diverter chute shall be provided in the enclosed distributor spinner hopper assembly so it can be positioned in such a manner that material can be unloaded from spreader without striking spinner. NOTE: Flip up chute is not acceptable)

FROM:

7.11.3 Strobe light shall be "quad flash"

TO:

7.11.3 Warning light shall be Class 1 LED amber

FROM:

7.14 One (1) piece of angle iron 3/8" x 4" x 90" and two (2) pieces of 1" round shafting ten inches (10") long shall be included to construct a safety keeper bar. State forces will add this item when the hopper is mounted, vendor shall supply material.

TO:

7.14 One (1) piece of angle iron 3/8" x 4" x 4" x 90" and two (2) pieces of 1" round shafting ten inches (10") long shall be included to construct a safety keeper bar. State forces will add this item when the hopper is mounted, vendor shall supply material.

PREBID ADDENDUM #1

7011EC14

5 CUBIC YARD STAINLESS STEEL
DEMOUNTABLE ABRASIVE AND CHEMICAL SPREADER (HYDRAULIC)

CHANGES TO BIDDER'S EVALUATION REPORT:

FROM:

X7.2 Does spreader consist of a 12 gauge 304 stainless steel body, feeder conveyor, spinner disc, power drive, and all components necessary to make a complete operating unit? N/A YES NO

TO:

X7.2 The spreader consists of a 12 gauge 304 stainless steel body, feeder conveyor, spinner disc, power drive, and all components necessary to make a complete operating unit? YES NO

FROM:

X7.4.2 Capacity struck: N/A Cubic Yards

TO:

X7.4.2 Struck capacity: 5 Cubic Yards

FROM:

X7.5.8 Is the chain drive through 1 1/2 " sprockets and shafting front and rear? YES NO

N/A

TO:

X7.5.8 The chain drive is through 1 1/2 inch sprockets and shafting front and rear? YES NO

FROM:

X7.5.12 Is conveyor drive motor mounted on hopper side of reduction gear box? YES NO

X7.5.12.1 Does the reduction gear box provide a 50:1 ratio? YES NO N/A

TO:

X7.5.12 Is conveyor drive motor mounted on rear of the reduction gear box YES NO

X7.5.12.1 The reduction gear box provides a ratio of 50:1

NO CHANGE REQUIRED:**X7.5.13 Does conveyor bear box motor have an integral speed sensor?** YES NO**NO CHANGE REQUIRED:****X7.6.4 Is a deflector baffle or diverter chute provided in an enclosed distributor spinner hopper assembly so it can be positioned in such a manner** YES NO**FROM:****X7.11.3 Strobe light is "quad flash" YES NO** N/A**TO:****X7.11.3 Is warning light Class 1 LED amber YES NO****FROM:****X7.14 Is one (1) piece of angle iron 3/8" x 4" x 90" and two (2) pieces of 1" round shafting ten inches (10") long provided but not installed for each unit YES NO** N/A**TO:****X7.14 Is one (1) piece of angle iron 3/8" x 4" x 4" x 90" and two (2) pieces of 1" round shafting ten inches (10") long provided but not installed for each unit YES NO**

Middletown Tractor Sales

2345 Whitehall blvd., Fairmont, WV 26554
Phone (304) 366-4690 Fax (304) 366-4698



JOHN DEERE

03-22-11

Department of Administration
Purchasing Division
Building 15
Attn: Sheri Slone
2019 Washington Street, East
Charleston, WV 25305-0130

Ms. Slone,

Please attach the enclosed addendums to the previously received bid 7011EC14 for Middletown Tractor Sales. Our initial bid and Addendum No.1 were sent in on 2-22-11 Via UPS. Reference tracking number 1z291x990150372837.

Thank you,

Zach Marsh
Aftermarket Manager

RECEIVED

2011 MAR 23 AM 10:29

WV PURCHASING
DIVISION



State of West Virginia
 Department of Administration
 Purchasing Division
 2019 Washington Street East
 Post Office Box 50130
 Charleston, WV 25305-0130

Request for Quotation

RFQ NUMBER
7011EC14

PAGE
3

ADDRESS CORRESPONDENCE TO ATTENTION OF
**BUYER 33
 304-558-2402**

**RFQ COPY
 TYPE NAME/ADDRESS HERE**

VENDOR

Middletown Tractor Sales
 2345 Whitehall Blvd.
 Fairmont, WV 26554

SHIP TO

**DIVISION OF HIGHWAYS
 EQUIPMENT DIVISION
 ROUTE 33
 BRUSHY FORK ROAD
 BUCKHANNON, WV
 26201 304-472-1750**

DATE PRINTED 12/29/2010	TERMS OF SALE NET30	SHIP VIA Truck	FOB Destination	FREIGHT TERMS Prepaid
BID OPENING DATE: 02/23/2011		BID OPENING TIME 01:30PM		

LINE	QUANTITY	UOP	CAT NO	ITEM NUMBER	UNIT PRICE	AMOUNT
<p>ADDENDUM(S) AND HAVE MADE THE NECESSARY REVISIONS TO MY PROPOSAL, PLANS AND/OR SPECIFICATION, ETC.</p> <p>ADDENDUM NO.'S:</p> <p>NO. 1 X</p> <p>NO. 2 X</p> <p>NO. 3 X</p> <p>NO. 4 X</p> <p>NO. 5</p> <p>I UNDERSTAND THAT FAILURE TO CONFIRM THE RECEIPT OF THE ADDENDUM(S) MAY BE CAUSE FOR REJECTION OF BIDS.</p> <p>VENDOR MUST CLEARLY UNDERSTAND THAT ANY VERBAL REPRESENTATION MADE OR ASSUMED TO BE MADE DURING ANY ORAL DISCUSSION HELD BETWEEN VENDOR'S REPRESENTATIVES AND ANY STATE PERSONNEL IS NOT BINDING. ONLY THE INFORMATION ISSUED IN WRITING AND ADDED TO THE SPECIFICATIONS BY AN OFFICIAL ADDENDUM IS BINDING.</p> <p>..... SIGNATURE Middletown Tractor Sales COMPANY 03-22-11 DATE</p>						

SEE REVERSE SIDE FOR TERMS AND CONDITIONS		
SIGNATURE <i>[Signature]</i>	TELEPHONE 304-366-4690	DATE 3-22-11
TITLE Aftermarket Mgr.	FEIN 550547175	ADDRESS CHANGES TO BE NOTED ABOVE

WHEN RESPONDING TO RFQ, INSERT NAME AND ADDRESS IN SPACE ABOVE LABELED 'VENDOR'



State of West Virginia
 Department of Administration
 Purchasing Division
 2019 Washington Street East
 Post Office Box 50130
 Charleston, WV 25305-0130

Request for Quotation

RFQ NUMBER
7011EC14

PAGE
1

ADDRESS CORRESPONDENCE TO ATTENTION OF
BUYER 33 304-558-2402

*709043751	304-366-4690
MIDDLETOWN TRACTOR SALES	
2345 WHITEHALL BLVD	
FAIRMONT WV 26554	

DIVISION OF HIGHWAYS	
EQUIPMENT DIVISION	
ROUTE 33	
BRUSHY FORK ROAD	
BUCKHANNON, WV	
26201	304-472-1750

DATE PRINTED	TERMS OF SALE	SHIP VIA	F.O.B.	FREIGHT TERMS		
02/23/2011	NET30	Truck	Destination	Prepaid		
BID OPENING DATE: 03/15/2011		BID OPENING TIME 01:30PM				
LINE	QUANTITY	UOP	CAT. NO.	ITEM NUMBER	UNIT PRICE	AMOUNT
ADDENDUM NO 2						
THIS ADDENDUM IS ISSUED TO EXTEND THE BID OPENING DATE FROM 02/23/2011 AT 1:30 PM TO 03/15/2011 AT 1:30 PM.						
*****END ADDENDUM NO. 2*****						
0001	1	LB		Monroe MSV-108-84-50-WV,08,304,12/10, 50:1, 1.5DR 570-64		\$9984.00
TO PROVIDE 5 CUBIC YARD STAINLESS STEEL,						
***** THIS IS THE END OF RFQ 7011EC14 ***** TOTAL:						\$9984.00

SEE REVERSE SIDE FOR TERMS AND CONDITIONS			
SIGNATURE	TELEPHONE	DATE	
<i>[Signature]</i>	304-366-4690	03-22-11	
TITLE	FEIN	ADDRESS CHANGES TO BE NOTED ABOVE	
Aftermarket Mgr.	550547175		

WHEN RESPONDING TO RFQ, INSERT NAME AND ADDRESS IN SPACE ABOVE LABELED 'VENDOR'



State of West Virginia
 Department of Administration
 Purchasing Division
 2019 Washington Street East
 Post Office Box 50130
 Charleston, WV 25305-0130

Request for Quotation

RFQ NUMBER
7011EC14

PAGE
1

ADDRESS CORRESPONDENCE TO ATTENTION OF
BUYER 33 304-558-2402

VENDOR	*709043751 304-366-4690
	MIDDLETOWN TRACTOR SALES 2345 WHITEHALL BLVD
	FAIRMONT WV 26554

SHIP TO	DIVISION OF HIGHWAYS EQUIPMENT DIVISION ROUTE 33 BRUSHY FORK ROAD BUCKHANNON, WV 26201 304-472-1750
---------	---

DATE PRINTED	TERMS OF SALE	SHIP VIA	F.O.B.	FREIGHT TERMS
03/10/2011	NET30	Truck	Destination	Prepaid
BID OPENING DATE: 03/23/2011		BID OPENING TIME 01:30PM		

LINE	QUANTITY	UOP	CAT NO.	ITEM NUMBER	UNIT PRICE	AMOUNT
ADDENDUM NO. 3 THIS ADDENDUM IS ISSUED TO EXTEND THE BID OPENING DATE FROM: 03/15/2011 AT 1:30 PM TO 03/23/2011 AT 1:30 PM *****END ADDENDUM NO. 3*****						
0001	1	LB		570-64	1.5DR	\$9984.00
TO PROVIDE 5 CUBIC YARD STAINLESS STEEL, ***** THIS IS THE END OF RFQ 7011EC14 ***** TOTAL:						\$9984.00

SEE REVERSE SIDE FOR TERMS AND CONDITIONS			
SIGNATURE	TELEPHONE	DATE	
<i>[Signature]</i>	304-366-4690	03-22-11	
TITLE	FEIN	ADDRESS CHANGES TO BE NOTED ABOVE	
Aftermarket Mgr.	550547175		

WHEN RESPONDING TO RFQ, INSERT NAME AND ADDRESS IN SPACE ABOVE LABELED 'VENDOR'



State of West Virginia
 Department of Administration
 Purchasing Division
 2019 Washington Street East
 Post Office Box 50130
 Charleston, WV 25305-0130

**Request for
 Quotation**

RFQ NUMBER
7011EC14

PAGE
1

ADDRESS CORRESPONDENCE TO ATTENTION OF:
BUYER 33 304-558-2402

VENDOR	*709043751 304-366-4690
	MIDDLETOWN TRACTOR SALES
	2345 WHITEHALL BLVD
	FAIRMONT WV 26554

SHIP TO	DIVISION OF HIGHWAYS
	EQUIPMENT DIVISION
	ROUTE 33
	BRUSHY FORK ROAD
	BUCKHANNON, WV 26201 304-472-1750

DATE PRINTED 03/14/2011	TERMS OF SALE NET30	SHIP VIA Truck	F.O.B. Destination	FREIGHT TERMS Prepaid
BID OPENING DATE: 03/23/2011		BID OPENING TIME 01:30PM		

LINE	QUANTITY	UOP	CAT NO.	ITEM NUMBER	UNIT PRICE	AMOUNT
ADDENDUM NO. 4						
THIS ADDENDUM IS ISSUED TO ADDRESS TECHNICAL QUESTIONS PER THE ATTACHED.						
THE BID OPENING DATE REMAIN 03/23/2011 AT 1:30 PM						
*****END ADDENDUM NO. 4*****						
0001	1	LB		570-64		\$9984.00
Monroe MSV-108-84-50-WV, 08, 304, 12/10, 50:1, 1.5DR						
TO PROVIDE 5 CUBIC YARD STAINLESS STEEL,						
***** THIS IS THE END OF RFQ 7011EC14 ***** TOTAL:						\$9984.00

SEE REVERSE SIDE FOR TERMS AND CONDITIONS			
SIGNATURE 	TELEPHONE 304-366-4690	DATE 03-22-11	
TITLE Aftermarket Mgr.	FEIN 550547175	ADDRESS CHANGES TO BE NOTED ABOVE	

WHEN RESPONDING TO RFQ, INSERT NAME AND ADDRESS IN SPACE ABOVE LABELED 'VENDOR'

ADDENDUM #4
7011EC14

5 CUBIC YARD STAINLESS STEEL
DEMOUNTABLE ABRASIVE AND CHEMICAL SPREADER (HYDRAULIC)

RESPONSE TO QUESTIONS

Pg 15 7.5.12 The conveyor drive motor shall be mounted on the hopper side of the reduction gear box and have a ratio of approximately 50:1. On the last contract, the motors were changed, installed to the rear, so the hoppers could be slid into the dump bodies further.

**RESPONSE: Addressed in the prebid addendum. CHANGED TO READ:
The conveyor drive motor shall be mounted on rear of the reduction gear box and have a ratio of approximately 50-1.**

Pg 28 X7.5.12 Is the conveyor drive motor mounted on hopper side if reduction gear box? On the last contract, we had to change the motor to the rear.

RESPONSE: Addressed on the prebid addendum. CHANGED TO READ:

X7.5.12 Is conveyor drive motor mounted on rear of the reduction gear box

X YES NO X7.5.12.1 The reduction gear box provides a ratio of 50:1

7.2 Would you accept 201 stainless steel in lieu of 304 stainless steel?

RESPONSE: No

7.4.1 Would you accept 201 stainless steel in lieu of 304 stainless steel?

RESPONSE: No

7.4.7 Would you accept 201 stainless steel in lieu of 304 stainless steel?

RESPONSE: No

7.4.9 Would you accept 201 stainless steel in lieu of 304 stainless steel?

RESPONSE: No

7.4.10 Would you accept 201 stainless steel in lieu of 304 stainless steel?

RESPONSE: No

7.4.11 Would you accept 201 stainless steel in lieu of 304 stainless steel?

RESPONSE: No

7.4.13 Would you accept 201 stainless steel in lieu of 304 stainless steel?

RESPONSE: No

7.5.6 Are the rubber wear strips length wide or are they on the end of the hopper over the chain?

RESPONSE: Over chain

7.5.7 Would you accept 201 stainless steel in lieu of 304 stainless steel?

RESPONSE: No

7.5.10 Would you accept 201 stainless steel in lieu of 304 stainless steel?

RESPONSE: No

7.5.13 Do you want the speed sensor built in the motor or on the gear box stub shaft?

RESPONSE: In motor

7.10.1 Would you accept 201 stainless steel in lieu of 304 stainless steel?

RESPONSE: No

7.14 Is the angle 4" x 4" x 3/8" x 90" long? **RESPONSE: Yes**

7.4.9 Does "angle formed cross sills" meet this spec? **RESPONSE: No**

7.5.13 I believe that this sentence should end, "integral speed sensor"
RESPONSE: Corrected in addendum #1

7.4.11 I haven't seen any mention of the spreader tie-down/mounting system, such as (4) chains and eye bolts or (4) ratchet straps.
RESPONSE: Tie down not included in specifications

7.4.13 Does the front spill shield have to be delivered mounted or can it be shipped loose inside the spreader?
RESPONSE: May be shipped loose

7.4.15 Does the work light have to be mounted or can it be shipped inside the spreader?
RESPONSE: May be shipped loose

7.5.6 Is a formed stainless steel chain shield acceptable in lieu of the removable rubber chain shield?
RESPONSE: No

7.10 Do the screens and beam have to be mounted or can they be shipped loose inside the spreader?
RESPONSE: May be shipped loose

7.10.1 Is a 6" x 9.0 lb I-beam acceptable in lieu of a box beam?
RESPONSE: No

1. Can you provide an estimate of quantity of units to be purchased in the 12 month period following the date of award?

RESPONSE: Undetermined

2. Will other stainless steel alloys other than 304 be acceptable?

RESPONSE: No

3. What are the desired dimensions for the fold-up ladder?

RESPONSE: Manufacturers standard

4. What are the desired dimensions for the stainless steel grip strut step plate to be mounted on the rear of the spinner housing frame?

RESPONSE: Manufacturers standard

5. Section 7.5.8 while pertaining to the same item on both units is different for the two spreaders. While one is mandatory (14), the other is not (15). Is a 1 ¼" idler shaft acceptable? And, is a 2" drive shaft acceptable? As written, these would be acceptable in the RFQ15 while not in the RFQ14.

RESPONSE: See Addendum #1

6. To comply with the 7.6.4 requirement for bulk unloading is a flip up spinner chute acceptable?

RESPONSE: No it is not – See Addendum #1

7. For top screen mounting, is a 6" channel cross beam acceptable?

RESPONSE: No it is not

8. On RFQ 14 is a 57" spreader height acceptable?

RESPONSE: Must list as exception

9. Is a 6.3 cubic yard capacity acceptable for RFQ14?

RESPONSE: No

11. The lighting drawing shows lights combined in housings but previous spreaders have been supplied with individual weatherproof housing as per the picture below. Are the individual weatherproof housings still allowed?

RESPONSE: As long as you still are in compliance with the spec.

FSH

Sand and Salt Spreader

Henderson

History repeats itself...times three. Meet the FSH-I, II and III precision spreaders.

The legendary Henderson FSH sand and salt spreader is now available in *three* versions. The FSH-I, II and III have subtle differences (see specification chart on back) to better meet varying specification requirements and specific customer needs.

The important features of the FSH are retained "across the board" on all three models. The rugged dependability, precision delivery of materials to the road surface and low

maintenance so ingrained in the FSH have all been retained. It's available in a variety of sizes to exactly conform to your specifications.

So now you don't have to settle for less than a Henderson FSH Spreader... regardless of your budget.

The Henderson FSH-I, II and III...

they're what you'd expect from...

The Dependable Ones



- Inside seams are continuously welded for extreme duty. Sides and ends are 10 ga. and floor is 7 ga. steel.
- Top edge of hopper is a formed "J" channel for added rigidity and strength.
- Conveyor is 24" wide, all steel pintle-type chain. The FSH-I and II have 1/4" x 1-1/2" crossbars while the FSH-III has 3/8" x 1-1/2" crossbars. Crossbars are spaced on 4-1/2" centers. Sprockets are cast iron and are keyed to the drive and idler shafts to prevent slippage and maintain chain alignment.
- OPTIONAL single or dual augers for reduced maintenance and smoothness of material flow.
- Conveyor chain is protected by a formed 10 ga. shield in the FSH-I and II. A replaceable bolt-in shield is standard on the FSH-III and optional on the FSH-II.
- Two 5/8" stainless steel chain adjusters with 4" of adjustment provide optimum chain tension.
- OPTIONAL Conveyor gearbox has thru-shaft for electronic control system speed sensor hook-up.
- The hydraulic motor is mounted directly to the gearcase to eliminate sprockets, chains and couplers for reduced maintenance.
- The telescopic chute assembly is 10 ga. steel and is totally enclosed with two internal adjustable baffles. Three external adjustable deflectors and one front fixed deflector with overlapping corners also contribute to precise control of material spread pattern. A quick latching bypass chute diverts material behind the spinner chute for fast unloading.
- The 20" spinner disk is 10 ga. steel with stainless steel fins. Polyurethane optional.
- All surfaces are high-pressure cleaned and degreased with a phosphate solution before being primed and finish painted with Highway Orange paint.

FEATURES & SPECIFICATIONS

LENGTH	CUBIC YARD CAPACITY (Struck/Rounded)			WEIGHTS (Approx.)			RECOMMENDED CAB TO AXLE (Inches)
	Side Height			Side Height			
	48" or 50"	54" or 56"	60" or 62"	50"	56"	62"	
8'	4.5/5.6	5.5/5.6	6.5/7.6	1760	1845	1930	60
9'	5.1/6.3	6.2/7.3	7.4/8.5	1905	1995	2085	72
10'	5.6/6.9	6.9/8.2	8.3/9.6	2070	2166	2262	84
11'	6.2/7.6	7.6/9.0	9.0/10.4	2225	2327	2429	96
12'	6.8/8.3	8.4/9.9	9.9/11.4	2380	2488	2596	108
13'	7.3/9.0	9.0/10.7	10.7/12.4	2535	2649	2763	96 C.T.
14'	7.9/9.8	9.7/11.4	11.6/13.3	2690	2810	2930	108 C.T.
15'	8.4/10.3	10.3/12.2	12.2/14.1	2845	2971	3097	120 C.T.
16'	8.9/10.9	11.0/13.0	13.0/15.0	3001	3132	3264	132 C.T.

FEATURE	FSH-I	FSH-II	FSH-III
Lengths	8' - 16'	8' - 16'	8' - 16'
Outside Width	84"	84"	84"
Overall Height	48", 54", 60" or 66"	50", 56", 62" or 68"	50", 56", 62" or 68"
Conveyor Style	<ul style="list-style-type: none"> •6-tooth sprockets •1-1/2" dia. drive shaft with roller bearings •Pintle type conveyor chain with 1/4" x 1-1/2" crossbars on 4-1/2" centers 	<ul style="list-style-type: none"> •8-tooth sprockets •1-1/2" dia. drive shaft with roller bearings •Pintle type conveyor chain with 1/4" x 1-1/2" crossbars on 4-1/2" centers 	<ul style="list-style-type: none"> •8-tooth sprockets •2" drive shaft with roller bearings •Pintle type conveyor chain with 3/8" x 1-1/2" crossbars 4-1/2" centers
Idler Type	<ul style="list-style-type: none"> •1-1/4" dia. shaft with roller bearings •4" idler adjustment spring loaded optional 	<ul style="list-style-type: none"> •1-1/2" dia. shaft with roller bearings •4" spring loaded idler adjustment 	<ul style="list-style-type: none"> •2" dia. shaft with roller bearings •4" spring loaded idler adjustment
Conveyor Gearbox Drive	50:1 worm gear standard 25:1 optional	50:1 worm gear standard 25:1 optional	6:1 spur gearbox 50:1 or 25:1 worm gearbox optional
Chain Shields	standard: formed	standard: formed bolt-in optional	standard: bolt-in replaceable

SPECIFICATIONS

BODY

Sides, ends and side supports are of 10 ga. steel and are continuous-seam welded from the inside. Side slope is 45° with front slope at 18° and rear slope 9°. Floor is replaceable 7 ga. steel. Longills are 7 ga. steel continuous-seam welded to the sides on mild steel units. Top edge of hopper is formed "J" channel, 1-5/8" x 3/4". Feed-gate is 10 ga. 10" x 18", screwjack adjustable from curb side. Download pressure is reduced by an adjustable inverted vee (optional) to reduce material compaction.

CONVEYOR

Rear discharge pintle chain conveyor is 24" wide. Chain tension adjusting rod is 5/8" stainless steel. Idler adjustment is 4".

CONVEYOR GEARBOX

The FSH-I and FSH-II have a 50:1 or 25:1 worm gearbox. In addition, the FSH-III has a 6:1 spur gearbox available.

SPINNER CHUTE ASSEMBLY

Completely enclosed telescopic design is of 10 ga. steel. Top-mounted hydraulic spinner motor is enclosed in the chute to maximize material

flow to the spinner disk, improving spread pattern. It is mounted directly to the spinner for elimination of shaft and bearings. Two (2) internal baffles direct material flow onto the spinner disk for directional spread control. Three external adjustable deflectors and one front fixed deflector with overlapping corners contribute to precise control of material spread pattern. The adjustable spinner deflectors are easily replaceable without tools for easy servicing. A quick latching spreader bypass chute diverts material behind spinner chute for fast unloading. Spinner disk is 20" diameter, 10 ga. steel with replaceable hub. Six (6) 10 ga. stainless steel vanes are bolt-on and replaceable.

PAINT

All metal surfaces are high pressure cleaned with a phosphate solution to remove slag, spatter, oxide and oil residue. The entire body is primed with a high quality catalyzed primer and then finished with Highway Orange grade enamel. The 304 Stainless Steel units are unpainted.

CONTROL VALVE - OPTIONAL

Speed of conveyor and spinner motors is controlled by a dual pressure compensated control valve with a relief pre-set at 1500PSI. Valve has twelve (12) detent settings for each circuit and an independent on/off valve to allow start/stop without changing application rate.

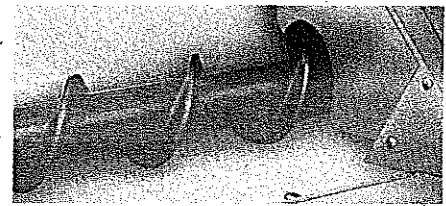

SINGLE AUGER CONVEYOR - OPTIONAL

Seven-inch (7") auger conveyor provides a more even flow than a standard chain conveyor with less maintenance. A patented safety interlock feature helps prevent personal injury from the auger.

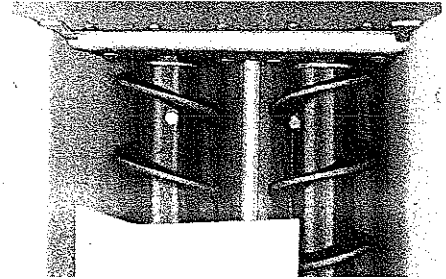

DUAL AUGER CONVEYOR - OPTIONAL

Two counter-rotating augers create a smooth spread, breaking up clumps and prevents bridging of materials.

Auger shafts utilize a polyurethane bushing at both ends of each auger to eliminate seizing and ensure ease of maintenance.

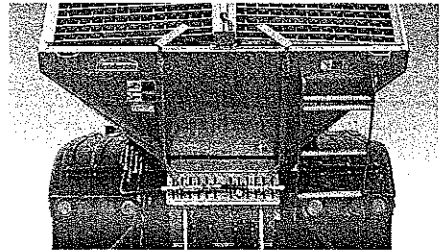

SAFETY INTERLOCK

Required with optional single or dual augers. For safety, auger motors must be disabled before operator can open top grate screens.

TOP GRATE SCREENS - OPTIONAL

Hinged, 3/8" welded rod heavy duty mesh screens keep unwanted larger materials out of the spreader.

FRONT IDLER AND GREASE TUBE EXTENSIONS - OPTIONAL

Grease and adjust tension easily from the rear of unit.

OPTIONS

- 304 Stainless Steel
- Top Grate Screens
- Inverted Vee
- Extended Front Idler Adjusters
- Extended Front Idler Grease Tubes
- Hold Down Kit
- 18 HP Engine Group
- Rubber Side Spill Shields
- Roller Chain
- Cab Shield
- Spacer Bars
- Ladders
- Bumpers
- Centerline Diverter Chute
- Catwalks and Frame Mount Kit
- Side Tubes and Rear Hoses
- Short Hose Kit with Quick Couplers
- Automatic Control Systems

P.O. Box 40 • Manchester, Iowa 52057
800-359-4970 • www.henderson-mfg.com

BAKER TRUCK EQUIPMENT
P O BOX 482
HURRICANE WV 25526

State of West Virginia

VENDOR PREFERENCE CERTIFICATE

Certification and application* is hereby made for Preference in accordance with West Virginia Code, §5A-3-37. (Does not apply to construction contracts). West Virginia Code, §5A-3-37, provides an opportunity for qualifying vendors to request (at the time of bid) preference for their residency status. Such preference is an evaluation method only and will be applied only to the cost bid in accordance with the West Virginia Code. This certificate for application is to be used to request such preference. The Purchasing Division will make the determination of the Resident Vendor Preference, if applicable.

- 1. Application is made for 2.5% resident vendor preference for the reason checked: Bidder is an individual resident vendor and has resided continuously in West Virginia for four (4) years immediately preceding the date of this certification; or, Bidder is a partnership, association or corporation resident vendor and has maintained its headquarters or principal place of business continuously in West Virginia for four (4) years immediately preceding the date of this certification; or 80% of the ownership interest of Bidder is held by another individual, partnership, association or corporation resident vendor who has maintained its headquarters or principal place of business continuously in West Virginia for four (4) years immediately preceding the date of this certification; or, Bidder is a nonresident vendor which has an affiliate or subsidiary which employs a minimum of one hundred state residents and which has maintained its headquarters or principal place of business within West Virginia continuously for the four (4) years immediately preceding the date of this certification; or,
2. Application is made for 2.5% resident vendor preference for the reason checked: Bidder is a resident vendor who certifies that, during the life of the contract, on average at least 75% of the employees working on the project being bid are residents of West Virginia who have resided in the state continuously for the two years immediately preceding submission of this bid; or,
3. Application is made for 2.5% resident vendor preference for the reason checked: Bidder is a nonresident vendor employing a minimum of one hundred state residents or is a nonresident vendor with an affiliate or subsidiary which maintains its headquarters or principal place of business within West Virginia employing a minimum of one hundred state residents who certifies that, during the life of the contract, on average at least 75% of the employees or Bidder's affiliate's or subsidiary's employees are residents of West Virginia who have resided in the state continuously for the two years immediately preceding submission of this bid; or,
4. Application is made for 5% resident vendor preference for the reason checked: Bidder meets either the requirement of both subdivisions (1) and (2) or subdivision (1) and (3) as stated above; or,
5. Application is made for 3.5% resident vendor preference who is a veteran for the reason checked: Bidder is an individual resident vendor who is a veteran of the United States armed forces, the reserves or the National Guard and has resided in West Virginia continuously for the four years immediately preceding the date on which the bid is submitted; or,
6. Application is made for 3.5% resident vendor preference who is a veteran for the reason checked: Bidder is a resident vendor who is a veteran of the United States armed forces, the reserves or the National Guard, if, for purposes of producing or distributing the commodities or completing the project which is the subject of the vendor's bid and continuously over the entire term of the project, on average at least seventy-five percent of the vendor's employees are residents of West Virginia who have resided in the state continuously for the two immediately preceding years.

Bidder understands if the Secretary of Revenue determines that a Bidder receiving preference has failed to continue to meet the requirements for such preference, the Secretary may order the Director of Purchasing to: (a) reject the bid; or (b) assess a penalty against such Bidder in an amount not to exceed 5% of the bid amount and that such penalty will be paid to the contracting agency or deducted from any unpaid balance on the contract or purchase order.

By submission of this certificate, Bidder agrees to disclose any reasonably requested information to the Purchasing Division and authorizes the Department of Revenue to disclose to the Director of Purchasing appropriate information verifying that Bidder has paid the required business taxes, provided that such information does not contain the amounts of taxes paid nor any other information deemed by the Tax Commissioner to be confidential.

Under penalty of law for false swearing (West Virginia Code, §61-5-3), Bidder hereby certifies that this certificate is true and accurate in all respects; and that if a contract is issued to Bidder and if anything contained within this certificate changes during the term of the contract, Bidder will notify the Purchasing Division in writing immediately.

Bidder: Middletown Tractor Sales

Signed: [Signature]

Date: 2-22-11

Title: Aftermarket Manager

*Check any combination of preference consideration(s) indicated above, which you are entitled to receive.

RFQ No. 7011EC14

STATE OF WEST VIRGINIA
Purchasing Division

PURCHASING AFFIDAVIT

West Virginia Code §5A-3-10a states: No contract or renewal of any contract may be awarded by the state or any of its political subdivisions to any vendor or prospective vendor when the vendor or prospective vendor or a related party to the vendor or prospective vendor is a debtor and the debt owed is an amount greater than one thousand dollars in the aggregate.

DEFINITIONS:

"Debt" means any assessment, premium, penalty, fine, tax or other amount of money owed to the state or any of its political subdivisions because of a judgment, fine, permit violation, license assessment, defaulted workers' compensation premium, penalty or other assessment presently delinquent or due and required to be paid to the state or any of its political subdivisions, including any interest or additional penalties accrued thereon.

"Debtor" means any individual, corporation, partnership, association, limited liability company or any other form or business association owing a debt to the state or any of its political subdivisions. "Political subdivision" means any county commission; municipality; county board of education; any instrumentality established by a county or municipality; any separate corporation or instrumentality established by one or more counties or municipalities, as permitted by law; or any public body charged by law with the performance of a government function or whose jurisdiction is coextensive with one or more counties or municipalities. "Related party" means a party, whether an individual, corporation, partnership, association, limited liability company or any other form or business association or other entity whatsoever, related to any vendor by blood, marriage, ownership or contract through which the party has a relationship of ownership or other interest with the vendor so that the party will actually or by effect receive or control a portion of the benefit, profit or other consideration from performance of a vendor contract with the party receiving an amount that meets or exceeds five percent of the total contract amount.

EXCEPTION: The prohibition of this section does not apply where a vendor has contested any tax administered pursuant to chapter eleven of this code, workers' compensation premium, permit fee or environmental fee or assessment and the matter has not become final or where the vendor has entered into a payment plan or agreement and the vendor is not in default of any of the provisions of such plan or agreement.

Under penalty of law for false swearing (*West Virginia Code §61-5-3*), it is hereby certified that the vendor affirms and acknowledges the information in this affidavit and is in compliance with the requirements as stated.

WITNESS THE FOLLOWING SIGNATURE

Vendor's Name: Middletown Tractor Sales

Authorized Signature: [Signature] Date: 2-22-11

State of WV

County of Taylor, to-wit:

Taken, subscribed, and sworn to before me this 22 day of FEBRUARY, 2011.

My Commission expires 9-30-, 2019.

AFFIX SEAL HERE

NOTARY PUBLIC [Signature]

