



State of West Virginia
 Department of Administration
 Purchasing Division
 2019 Washington Street East
 Post Office Box 50130
 Charleston, WV 25305-0130

Request for Quotation

RFQ NUMBER
 7011EC10

PAGE
 1

ADDRESS CORRESPONDENCE TO ATTENTION OF:
 BUYER 33
 304-558-2402

VENDOR

Matheny Motor Truck Company
 P O Box 1304
 Parkersburg WV 26101

SHIP TO

DIVISION OF HIGHWAYS
 EQUIPMENT DIVISION
 ROUTE 33
 BRUSHY FORK ROAD
 BUCKHANNON, WV
 26201 304-472-1750

PURCHASING COPY

DATE PRINTED 12/09/2010	TERMS OF SALE NET 30 DAYS	SHIP VIA GROUND	F.O.B. BUCKHANNON, WV	FREIGHT TERMS PREPAID
BID OPENING DATE: 01/20/2011		BID OPENING TIME 01:30PM		

LINE	QUANTITY	UOP	CAT NO	ITEM NUMBER	UNIT PRICE	AMOUNT
0001	1	EA		FREIGHTLINER 065-30	\$139,687.00	\$139,687.00
64,000 GVW CAB, CHASSIS, DUMP BODY, HYDRAULIC SYSTEM REQUEST FOR QUOTATION (RFQ) OPEN END CONTRACT THE WEST VIRGINIA STATE PURCHASING DIVISION FOR THE AGENCY, THE WEST VIRGINIA DIVISION OF HIGHWAYS, IS SOLICITING BIDS FOR AN OPEN END CONTRACT TO PROVIDE 64,000 GVW CAB AND CHASSIS, DUMP BODY, AND HYDRAULIC SYSTEM, PER THE ATTACHED SPECIFICATIONS. A MANDATORY PRE-BID WILL BE HELD ON 01/06/11 AT 10:00 AM, BRUSHY FORK RD IN BUCKHANNON, WV 26201. ALL INTERESTED PARTIES ARE REQUIRED TO ATTEND THIS MEETING. FAILURE TO ATTEND THE MANDATORY PRE-BID SHALL RESULT IN DISQUALIFICATION OF THE BID. NO ONE PERSON MAY REPRESENT MORE THAN ONE BIDDER. AN ATTENDANCE SHEET WILL BE MADE AVAILABLE FOR ALL POTENTIAL BIDDERS TO COMPLETE. THIS WILL SERVE AS THE OFFICIAL DOCUMENT VERIFYING ATTENDANCE AT THE MANDATORY PRE-BID. FAILURE TO PROVIDE YOUR COMPANY AND REPRESENTATIVE NAME ON THE ATTENDANCE SHEET WILL RESULT IN DISQUALIFICATION OF THE BID. THE STATE WILL NOT ACCEPT ANY OTHER DOCUMENTATION TO VERIFY ATTENDANCE. THE BIDDER IS RESPONSIBLE FOR ENSURING THEY HAVE COMPLETED THE INFORMATION REQUIRED ON THE ATTENDANCE SHEET. THE PURCHASING DIVISION AND THE STATE AGENCY						

RECEIVED
 2011 MAR 10 PM 12:43
 WV PURCHASING DIVISION

SIGNATURE <i>M. J. Matheny</i>				SEE REVERSE SIDE FOR TERMS AND CONDITIONS	
TITLE CEO	FEIN 55-032-0770	TELEPHONE 304-485-4418	DATE 02/15/11	ADDRESS CHANGES TO BE NOTED ABOVE	

WHEN RESPONDING TO RFQ, INSERT NAME AND ADDRESS IN SPACE ABOVE LABELED 'VENDOR'

GENERAL TERMS & CONDITIONS REQUEST FOR QUOTATION (RFQ) AND REQUEST FOR PROPOSAL (RFP)

1. Awards will be made in the best interest of the State of West Virginia.
2. The State may accept or reject in part, or in whole, any bid.
3. Prior to any award, the apparent successful vendor must be properly registered with the Purchasing Division and have paid the required \$125 fee.
4. All services performed or goods delivered under State Purchase Order/Contracts are to be continued for the term of the Purchase Order/Contracts, contingent upon funds being appropriated by the Legislature or otherwise being made available. In the event funds are not appropriated or otherwise available for these services or goods this Purchase Order/Contract becomes void and of no effect after June 30.
5. Payment may only be made after the delivery and acceptance of goods or services.
6. Interest may be paid for late payment in accordance with the *West Virginia Code*.
7. Vendor preference will be granted upon written request in accordance with the *West Virginia Code*.
8. The State of West Virginia is exempt from federal and state taxes and will not pay or reimburse such taxes.
9. The Director of Purchasing may cancel any Purchase Order/Contract upon 30 days written notice to the seller.
10. The laws of the State of West Virginia and the *Legislative Rules* of the Purchasing Division shall govern the purchasing process.
11. Any reference to automatic renewal is hereby deleted. The Contract may be renewed only upon mutual written agreement of the parties.
12. **BANKRUPTCY:** In the event the vendor/contractor files for bankruptcy protection, the State may deem this contract null and void, and terminate such contract without further order.
13. **HIPAA BUSINESS ASSOCIATE ADDENDUM:** The West Virginia State Government HIPAA Business Associate Addendum (BAA), approved by the Attorney General, is available online at www.state.wv.us/admin/purchase/vrc/hipaa.htm and is hereby made part of the agreement. Provided that the Agency meets the definition of a Cover Entity (45 CFR §160.103) and will be disclosing Protected Health Information (45 CFR §160.103) to the vendor.
14. **CONFIDENTIALITY:** The vendor agrees that he or she will not disclose to anyone, directly or indirectly, any such personally identifiable information or other confidential information gained from the agency, unless the individual who is the subject of the information consents to the disclosure in writing or the disclosure is made pursuant to the agency's policies, procedures, and rules. Vendor further agrees to comply with the Confidentiality Policies and Information Security Accountability Requirements, set forth in <http://www.state.wv.us/admin/purchase/privacy/noticeConfidentiality.pdf>.
15. **LICENSING:** Vendors must be licensed and in good standing in accordance with any and all state and local laws and requirements by any state or local agency of West Virginia, including, but not limited to, the West Virginia Secretary of State's Office, the West Virginia Tax Department, and the West Virginia Insurance Commission. The vendor must provide all necessary releases to obtain information to enable the director or spending unit to verify that the vendor is licensed and in good standing with the above entities.
16. **ANTITRUST:** In submitting a bid to any agency for the State of West Virginia, the bidder offers and agrees that if the bid is accepted the bidder will convey, sell, assign or transfer to the State of West Virginia all rights, title and interest in and to all causes of action it may now or hereafter acquire under the antitrust laws of the United States and the State of West Virginia for price fixing and/or unreasonable restraints of trade relating to the particular commodities or services purchased or acquired by the State of West Virginia. Such assignment shall be made and become effective at the time the purchasing agency tenders the initial payment to the bidder.

I certify that this bid is made without prior understanding, agreement, or connection with any corporation, firm, limited liability company, partnership, or person or entity submitting a bid for the same material, supplies, equipment or services and is in all respects fair and without collusion or fraud. I further certify that I am authorized to sign the certification on behalf of the bidder or this bid.

INSTRUCTIONS TO BIDDERS

1. Use the quotation forms provided by the Purchasing Division. Complete all sections of the quotation form.
2. Items offered must be in compliance with the specifications. Any deviation from the specifications must be clearly indicated by the bidder. Alternates offered by the bidder as **EQUAL** to the specifications must be clearly defined. A bidder offering an alternate should attach complete specifications and literature to the bid. The Purchasing Division may waive minor deviations to specifications.
3. Unit prices shall prevail in case of discrepancy. All quotations are considered F.O.B. destination unless alternate shipping terms are clearly identified in the quotation.
4. All quotations must be delivered by the bidder to the office listed below prior to the date and time of the bid opening. Failure of the bidder to deliver the quotations on time will result in bid disqualifications: Department of Administration, Purchasing Division, 2019 Washington Street East, P.O. Box 50130, Charleston, WV 25305-0130
5. Communication during the solicitation, bid, evaluation or award periods, except through the Purchasing Division, is strictly prohibited (W.Va. C.S.R. §148-1-6.6).



State of West Virginia
 Department of Administration
 Purchasing Division
 2019 Washington Street East
 Post Office Box 50130
 Charleston, WV 25305-0130

Request for Quotation

RFO NUMBER
 7011EC10

PAGE
 2

ADDRESS CORRESPONDENCE TO ATTENTION OF
 BUYER 33
 304-558-2402

RFQ COPY
 TYPE NAME/ADDRESS HERE

V
E
N
D
O
R

S
H
I
P
T
O

DIVISION OF HIGHWAYS
 EQUIPMENT DIVISION
 ROUTE 33
 BRUSHY FORK ROAD
 BUCKHANNON, WV
 26201 304-472-1750

DATE PRINTED 12/09/2010	TERMS OF SALE	SHIP VIA	F.O.B.	FREIGHT TERMS
----------------------------	---------------	----------	--------	---------------

BID OPENING DATE: 01/20/2011 BID OPENING TIME 01:30PM

LINE	QUANTITY	UOP	CAT NO	ITEM NUMBER	UNIT PRICE	AMOUNT
<p>WILL NOT ASSUME ANY RESPONSIBILITY FOR A BIDDER-S FAILURE TO COMPLETE THE PRE-BID ATTENDANCE SHEET. IN ADDITION, WE REQUEST THAT ALL POTENTIAL BIDDERS INCLUDE THEIR E-MAIL ADDRESS AND FAX NUMBER.</p> <p>ALL POTENTIAL BIDDERS ARE REQUESTED TO ARRIVE PRIOR TO THE STARTING TIME FOR THE PRE-BID. BIDDERS WHO ARRIVE LATE, BUT PRIOR TO THE DISMISSAL OF THE TECHNICAL PORTION OF THE PRE-BID WILL BE PERMITTED TO SIGN IN. BIDDERS WHO ARRIVE AFTER CONCLUSION OF THE TECHNICAL PORTION OF THE PRE-BID, BUT DURING ANY SUBSEQUENT PART OF THE PRE-BID WILL NOT BE PERMITTED TO SIGN THE ATTENDANCE SHEET.</p> <p>TECHNICAL QUESTIONS CONCERNING THIS SOLICITATION MUST BE SUBMITTED IN WRITING TO SHERI SLONE IN THE WEST VIRGINIA STATE PURCHASING DIVISION VIA MAIL AT THE ADDRESS SHOWN IN THE BODY OF THIS RFQ, VIA FAX 304-558-2596, OR VIA EMAIL AT SHERI.D.SLONE@WV.GOV. DEADLINE FOR ALL TECHNICAL QUESTIONS IS 12/28/2010 AT THE CLOSE OF BUSINESS. ANY TECHNICAL QUESTIONS RECEIVED WILL BE ANSWERED BY FORMAL ADDENDUM TO BE ISSUED BY THE PURCHASING DIVISION AFTER THE DEADLINE HAS LAPSED.</p> <p>EXHIBIT 2</p> <p>LIFE OF CONTRACT: THIS CONTRACT BECOMES EFFECTIVE ON ----- AND EXTENDS FOR A PERIOD OF ONE (1) YEAR OR UNTIL SUCH "REASONABLE TIME" THEREAFTER AS IS NECESSARY TO OBTAIN A NEW CONTRACT OR RENEW THE ORIGINAL CONTRACT. THE "REASONABLE TIME" PERIOD SHALL NOT EXCEED TWELVE (12) MONTHS. DURING THIS "REASONABLE TIME" THE VENDOR MAY TERMINATE THIS CONTRACT FOR</p>						

SEE REVERSE SIDE FOR TERMS AND CONDITIONS

SIGNATURE <i>MJ Mathews</i>	TELEPHONE	DATE
TITLE	FEIN	ADDRESS CHANGES TO BE NOTED ABOVE

WHEN RESPONDING TO RFQ, INSERT NAME AND ADDRESS IN SPACE ABOVE LABELED 'VENDOR'



State of West Virginia
 Department of Administration
 Purchasing Division
 2019 Washington Street East
 Post Office Box 50130
 Charleston, WV 25305-0130

Request for Quotation

RFQ NUMBER
 7011EC10

PAGE
 3

ADDRESS CORRESPONDENCE TO ATTENTION OF:
 BUYER 33
 304-558-2402

RFQ COPY
 TYPE NAME/ADDRESS HERE

VENDOR

SHIP TO

DIVISION OF HIGHWAYS
 EQUIPMENT DIVISION
 ROUTE 33
 BRUSHY FORK ROAD
 BUCKHANNON, WV
 26201 304-472-1750

DATE PRINTED	TERMS OF SALE	SHIP VIA	F.O.B.	FREIGHT TERMS
12/09/2010				

BID OPENING DATE: 01/20/2011 BID OPENING TIME 01:30PM

LINE	QUANTITY	UOP	CAT NO.	ITEM NUMBER	UNIT PRICE	AMOUNT
<p>ANY REASON UPON GIVING THE DIRECTOR OF PURCHASING THIRTY (30) DAYS WRITTEN NOTICE.</p> <p>UNLESS SPECIFIC PROVISIONS ARE STIPULATED IN THIS CONTRACT DOCUMENT, THE TERMS, CONDITIONS, AND PRICING SET HEREIN ARE FIRM FOR THE LIFE OF THE CONTRACT.</p> <p>RENEWAL: THIS CONTRACT MAY BE RENEWED UPON THE MUTUAL WRITTEN CONSENT OF THE SPENDING UNIT AND VENDOR, SUBMITTED TO THE DIRECTOR OF PURCHASING THIRTY (30) DAYS PRIOR TO THE EXPIRATION DATE. SUCH RENEWAL SHALL BE IN ACCORDANCE WITH THE TERMS AND CONDITIONS OF THE ORIGINAL CONTRACT AND SHALL BE LIMITED TO TWO (2) ONE (1) YEAR PERIODS.</p> <p>CANCELLATION: THE DIRECTOR OF PURCHASING RESERVES THE RIGHT TO CANCEL THIS CONTRACT IMMEDIATELY UPON WRITTEN NOTICE TO THE VENDOR IF THE COMMODITIES AND/OR SERVICE SUPPLIED ARE OF AN INFERIOR QUALITY OR DO NOT CONFORM WITH THE SPECIFICATIONS OF THE BID AND CONTRACT HEREIN.</p> <p>OPEN MARKET CLAUSE: THE DIRECTOR OF PURCHASING MAY AUTHORIZE A SPENDING UNIT TO PURCHASE ON THE OPEN MARKET, WITHOUT THE FILING OF A REQUISITION OR COST ESTIMATE, ITEMS SPECIFIED ON THIS CONTRACT FOR IMMEDIATE DELIVERY IN EMERGENCIES DUE TO UNFORESEEN CAUSES (INCLUDING BUT NOT LIMITED TO DELAYS IN TRANSPORTATION OR AN UNANTICIPATED INCREASE IN THE VOLUME OF WORK).</p> <p>QUANTITIES: QUANTITIES LISTED IN THE REQUISITION ARE APPROXIMATIONS ONLY, BASED ON ESTIMATES SUPPLIES BY THE STATE SPENDING UNIT. IT IS UNDERSTOOD AND AGREED THAT THE CONTRACT SHALL COVER THE QUANTITIES ACTUALLY ORDERED FOR DELIVERY DURING THE TERM OF CONTRACT, WHETHER MORE OR LESS THAN THE QUANTITIES SHOWN.</p>						

SEE REVERSE SIDE FOR TERMS AND CONDITIONS

SIGNATURE <i>M. J. [Signature]</i>	TELEPHONE	DATE
TITLE	FEIN	ADDRESS CHANGES TO BE NOTED ABOVE

WHEN RESPONDING TO RFQ, INSERT NAME AND ADDRESS IN SPACE ABOVE LABELED 'VENDOR'



State of West Virginia
 Department of Administration
 Purchasing Division
 2019 Washington Street East
 Post Office Box 50130
 Charleston, WV 25305-0130

Request for Quotation

RFO NUMBER
 7011EC10

PAGE
 4

ADDRESS CORRESPONDENCE TO ATTENTION OF
 BUYER 33
 304-558-2402

RFQ COPY
 TYPE NAME/ADDRESS HERE

VENDOR

SHIP TO

DIVISION OF HIGHWAYS
 EQUIPMENT DIVISION
 ROUTE 33
 BRUSHY FORK ROAD
 BUCKHANNON, WV
 26201 304-472-1750

DATE PRINTED 12/09/2010	TERMS OF SALE	SHIP VIA	F.O.B.	FREIGHT TERMS
----------------------------	---------------	----------	--------	---------------

BID OPENING DATE: 01/20/2011 BID OPENING TIME 01:30PM

LINE	QUANTITY	UOP	CAT NO	ITEM NUMBER	UNIT PRICE	AMOUNT
<p>ORDERING PROCEDURE: SPENDING UNIT(S) SHALL ISSUE A WRITTEN EQUIPMENT CONTRACT ORDER (FORM NUMBER WV-35) FOR COMMODITIES COVERED BY THIS CONTRACT. THE ORIGINAL WV-35 MUST BE SENT TO THE PURCHASING DIVISION OF THE DEPARTMENT OF ADMINISTRATION. AFTER APPROVAL AND ENCUMBRANCE, ONE COPY OF THE PURCHASE ORDER WILL BE RETURNED TO THE SPENDING UNIT AND ONE COPY FORWARDED TO THE VENDOR AS AUTHORIZATION FOR SHIPMENT. NO ORDER IS VALID UNLESS APPROVED AND ENCUMBERED BY THE PURCHASING DIVISION.</p> <p>BANKRUPTCY: IN THE EVENT THE VENDOR/CONTRACTOR FILES FOR BANKRUPTCY PROTECTION, THE STATE MAY DEEM THE CONTRACT NULL AND VOID, AND TERMINATE SUCH CONTRACT WITHOUT FUTHER ORDER.</p> <p>REV. 5/2009</p> <p>EXHIBIT 10</p> <p style="text-align: right;">REQUISITION NO.: 7011EC10.....</p> <p>ADDENDUM ACKNOWLEDGEMENT</p> <p>I HEREBY ACKNOWLEDGE RECEIPT OF THE FOLLOWING CHECKED ADDENDUM(S) AND HAVE MADE THE NECESSARY REVISIONS TO MY PROPOSAL, PLANS AND/OR SPECIFICATION, ETC.</p> <p>ADDENDUM NO.'S:</p> <p>NO. 1 <i>M.J. Matthews</i></p> <p>NO. 2 <i>M.J. Matthews</i></p> <p>NO. 3 <i>M.J. Matthews</i></p>						

SEE REVERSE SIDE FOR TERMS AND CONDITIONS

SIGNATURE <i>M.J. Matthews</i>	TELEPHONE	DATE
TITLE	FEIN	ADDRESS CHANGES TO BE NOTED ABOVE

WHEN RESPONDING TO RFQ, INSERT NAME AND ADDRESS IN SPACE ABOVE LABELED 'VENDOR'



State of West Virginia
 Department of Administration
 Purchasing Division
 2019 Washington Street East
 Post Office Box 50130
 Charleston, WV 25305-0130

**Request for
 Quotation**

RFQ NUMBER
 7011EC10

PAGE
 5

ADDRESS CORRESPONDENCE TO ATTENTION OF
 BUYER 33
 304-558-2402

RFQ COPY
 TYPE NAME/ADDRESS HERE

PROPERTY

SHIP TO

DIVISION OF HIGHWAYS
 EQUIPMENT DIVISION
 ROUTE 33
 BRUSHY FORK ROAD
 BUCKHANNON, WV
 26201 304-472-1750

DATE PRINTED	TERMS OF SALE	SHIP VIA	FOB	FREIGHT TERMS
12/09/2010				

BID OPENING DATE: 01/20/2011 BID OPENING TIME 01:30PM

LINE	QUANTITY	UOP	CAT NO	ITEM NUMBER	UNIT PRICE	AMOUNT
------	----------	-----	--------	-------------	------------	--------

NO. 4 *M.J. Matheny*
 NO. 5 *M.J. Matheny*
 NO. 6 *M.J. Matheny*

I UNDERSTAND THAT FAILURE TO CONFIRM THE RECEIPT OF TH
 ADDENDUM(S) MAY BE CAUSE FOR REJECTION OF BIDS.

VENDOR MUST CLEARLY UNDERSTAND THAT ANY VERBAL
 REPRESENTATION MADE OR ASSUMED TO BE MADE DURING ANY
 ORAL DISCUSSION HELD BETWEEN VENDOR'S REPRESENTATIVES
 AND ANY STATE PERSONNEL IS NOT BINDING. ONLY THE
 INFORMATION ISSUED IN WRITING AND ADDED TO THE
 SPECIFICATIONS BY AN OFFICIAL ADDENDUM IS BINDING.

.....*M.J. Matheny*.....
 SIGNATURE
 MATHENY MOTOR TRUCK CO.....
 COMPANY
 02/15/11
 DATE

NOTE: THIS ADDENDUM ACKNOWLEDGEMENT SHOULD BE SUBMITTED
 WITH THE BID.

REV. 09/21/2009

EXHIBIT 4

LOCAL GOVERNMENT BODIES: UNLESS THE VENDOR INDICATES
 IN THE BID HIS REFUSAL TO EXTEND THE PRICES, TERMS,

SEE REVERSE SIDE FOR TERMS AND CONDITIONS

SIGNATURE <i>M.J. Matheny</i>	TELEPHONE	DATE
TITLE	FEIN	ADDRESS CHANGES TO BE NOTED ABOVE

WHEN RESPONDING TO RFQ, INSERT NAME AND ADDRESS IN SPACE ABOVE LABELED 'VENDOR'



State of West Virginia
 Department of Administration
 Purchasing Division
 2019 Washington Street East
 Post Office Box 50130
 Charleston, WV 25305-0130

Request for Quotation

RFQ NUMBER
7011EC10

PAGE
6

ADDRESS CORRESPONDENCE TO ATTENTION OF:
 BUYER 33
 304-558-2402

VENDOR

RFQ COPY
 TYPE NAME/ADDRESS HERE

SHIP TO

DIVISION OF HIGHWAYS
 EQUIPMENT DIVISION
 ROUTE 33
 BRUSHY FORK ROAD
 BUCKHANNON, WV
 26201 304-472-1750

DATE PRINTED	TERMS OF SALE	SHIP VIA	F.O.B.	FREIGHT TERMS
12/09/2010				

BID OPENING DATE: **01/20/2011** BID OPENING TIME **01:30PM**

LINE	QUANTITY	UOP	CAT NO	ITEM NUMBER	UNIT PRICE	AMOUNT
<p>AND CONDITIONS OF THE BID TO COUNTY, SCHOOL, MUNICIPAL AND OTHER LOCAL GOVERNMENT BODIES, THE BID SHALL EXTEND TO POLITICAL SUBDIVISIONS OF THE STATE OF WEST VIRGINIA. IF THE VENDOR DOES NOT WISH TO EXTEND THE PRICES, TERMS, AND CONDITIONS OF THE BID TO ALL POLITICAL SUBDIVISIONS OF THE STATE, THE VENDOR MUST CLEARLY INDICATE SUCH REFUSAL IN HIS BID. SUCH REFUSAL SHALL NOT PREJUDICE THE AWARD OF THIS CONTRACT IN ANY MANNER.</p> <p>REV. 3/88</p> <p style="text-align: center;">NOTICE</p> <p>A SIGNED BID MUST BE SUBMITTED TO:</p> <p style="text-align: center;">DEPARTMENT OF ADMINISTRATION PURCHASING DIVISION BUILDING 15 2019 WASHINGTON STREET, EAST CHARLESTON, WV 25305-0130</p> <p>THE BID SHOULD CONTAIN THIS INFORMATION ON THE FACE OF THE ENVELOPE OR THE BID MAY NOT BE CONSIDERED:</p> <p>SEALED BID</p> <p>BUYER: SHERI SLONE - FILE 33</p> <p>RFQ. NO.: 7011EC10</p> <p>BID OPENING DATE: 01/20/2011</p>						

SEE REVERSE SIDE FOR TERMS AND CONDITIONS

SIGNATURE <i>M. Matheson</i>	TELEPHONE	DATE
TITLE	FEIN	ADDRESS CHANGES TO BE NOTED ABOVE

WHEN RESPONDING TO RFQ, INSERT NAME AND ADDRESS IN SPACE ABOVE LABELED 'VENDOR'



State of West Virginia
 Department of Administration
 Purchasing Division
 2019 Washington Street East
 Post Office Box 50130
 Charleston, WV 25305-0130

Request for Quotation

RFQ NUMBER
7011EC10

PAGE
7

ADDRESS CORRESPONDENCE TO ATTENTION OF
 BUYER 33
 304-558-2402

RFQ COPY
 TYPE NAME/ADDRESS HERE

VENDOR

SHIP TO

DIVISION OF HIGHWAYS
 EQUIPMENT DIVISION
 ROUTE 33
 BRUSHY FORK ROAD
 BUCKHANNON, WV
 26201 304-472-1750

DATE PRINTED	TERMS OF SALE	SHIP VIA	F.O.B.	FREIGHT TERMS
12/09/2010				

BID OPENING DATE: **01/20/2011** BID OPENING TIME **01:30PM**

LINE	QUANTITY	UOP	CAT NO	ITEM NUMBER	UNIT PRICE	AMOUNT
BID OPENING TIME:				1:30 PM		
PLEASE PROVIDE A FAX NUMBER IN CASE IT IS NECESSARY TO CONTACT YOU REGARDING YOUR BID:						
----- 304-485-2577 -----						
CONTACT PERSON (PLEASE PRINT CLEARLY):						
----- MIKE MATHENY -----						
***** THIS IS THE END OF RFQ 7011EC10 ***** TOTAL:						\$139,687.00

SEE REVERSE SIDE FOR TERMS AND CONDITIONS

SIGNATURE <i>m/j matheny</i>	TELEPHONE	DATE
TITLE	FEIN	ADDRESS CHANGES TO BE NOTED ABOVE

WHEN RESPONDING TO RFQ, INSERT NAME AND ADDRESS IN SPACE ABOVE LABELED 'VENDOR'



State of West Virginia
 Department of Administration
 Purchasing Division
 2019 Washington Street East
 Post Office Box 50130
 Charleston, WV 25305-0130

Request for Quotation

RFQ NUMBER
 7011EC10

PAGE
 1

ADDRESS CORRESPONDENCE TO ATTENTION OF:
 BUYER 33
 304-558-2402

VENDOR
 *709035314 304-485-4410
 MATHENY MOTOR TRUCK COMPANY
 PO BOX 1304
 PARKERSBURG WV 26102-1304

SHIP TO
 DIVISION OF HIGHWAYS
 EQUIPMENT DIVISION
 ROUTE 33
 BRUSHY FORK ROAD
 BUCKHANNON, WV
 26201 304-472-1750

DATE PRINTED 12/17/2010	TERMS OF SALE NET 30 DAYS	SHIP VIA GROUND	FOB BUCKHANNON, WV	FREIGHT TERMS PREPAID
BID OPENING DATE: 01/20/2011		BID OPENING TIME 01:30PM		

LINE	QUANTITY	UOP	CAT NO.	ITEM NUMBER	UNIT PRICE	AMOUNT
ADDENDUM NO. 1						
THIS ADDENDUM IS ISSUED TO ADDRESS CHANGES TO THE FOLLOWING SPECIFICATION SECTIONS, PER THE ATTACHED						
1.) 9.9						
2.) 9.9.1						
3.) 9.9.2						
4.) 9.9.6						
5.) 9.9.7						
*****END ADDENDUM NO. 1*****						
0001	1	EA		065-30		
64,000 GVW CAB, CHASSIS, DUMP BODY, HYDRAULIC SYSTEM						

SEE REVERSE SIDE FOR TERMS AND CONDITIONS

SIGNATURE <i>M. Matheny</i>	TELEPHONE 304-485-4418	DATE 02/15/11
TITLE CEO	FEIN 55-032-0770	ADDRESS CHANGES TO BE NOTED ABOVE

WHEN RESPONDING TO RFQ, INSERT NAME AND ADDRESS IN SPACE ABOVE LABELED 'VENDOR'

**ADDENDUM #1
OPEN END CONTRACT 70-11-EC10**

64,000 GVW CAB AND CHASSIS, DUMP BODY, AND HYDRAULIC SYSTEM

CHANGES TO BIDDER'S EVALUATION:

NO CHANGE REQUIRED:

X9.9 TAILGATE: SLOPED ASPHALT STYLE

FROM:

X9.9.1 Tailgate hinged at top with flush mount, ½ inch flame cut pivots, one (1) inch pork chop type off-set hardware to achieve maximum opening of tailgate, **but have provisions for pivoting at bottom** _____ YES _____ NO

TO:

X9.9.1 Does body have sloped rear corner posts with a tapered bottom angle to give adequate clearance when dumping into an asphalt paver or chip machine? _____ YES _____ NO

Clearance from bottom corner of rear corner post to ground when body is at 50 degree dump angle: _____ Inches

FROM:

X9.9.2 Top hinge channel with removable, chain tethered keeper pins _____ YES _____ NO

TO:

X9.9.2 Is tailgate hinged at top with flush mount, ½ inch flame cut tailgate pivots, one (1) inch pork chop type off-set hardware to achieve maximum opening of tailgate _____ YES _____ NO

Are there provisions for pivoting at bottom _____ YES _____ NO

ADD:

X9.9.6 Is the design and strength characteristics of entire dump unit such that the unit structural members and the hoisting system will not suffer any deformation, damage, or structural failure resulting from raising a distributed full payload _____ YES _____ NO

ADD:

X9.9.7 Is the location of the dump box pivot point in relation to the rear end of the truck frame and in relation to the rear lip of the box floor such that the horizontal distance from floor lip to the rear end of frame _____ inches. _____ YES _____ NO



State of West Virginia
 Department of Administration
 Purchasing Division
 2019 Washington Street East
 Post Office Box 50130
 Charleston, WV 25305-0130

Request for Quotation

RFQ NUMBER
 7011EC10

PAGE
 1

ADDRESS CORRESPONDENCE TO ATTENTION OF:
 BUYER 33
 304-558-2402

*709035314 304-485-4410
 MATHENY MOTOR TRUCK COMPANY
 PO BOX 1304
 PARKERSBURG WV 26102-1304

DIVISION OF HIGHWAYS
 EQUIPMENT DIVISION
 ROUTE 33
 BRUSHY FORK ROAD
 BUCKHANNON, WV
 26201 304-472-1750

DATE PRINTED	TERMS OF SALE	SHIP VIA	F.O.B.	FREIGHT TERMS
01/11/2011	NET 30 DAYS	GROUND	BUCKHANNON, WV	PREPAID
SID OPENING DATE: 02/10/2011		BID OPENING TIME 01:30PM		

LINE	QUANTITY	UOP	CAT NO	ITEM NUMBER	UNIT PRICE	AMOUNT
ADDENDUM NO. 2						
THIS ADDENDUM IS ISSUED TO:						
1.) EXTEND THE BID OPENING DATE FROM 01/20/2011 @ 1:30 PM TO 02/10/2011 @ 1:30PM						
2.) TO PROVIDE A COPY OF THE MANDATORY PRE-BID MEETING SIGN IN SHEET.						
*****END ADDENDUM NO. 2*****						
0001	1	EA		065-30		
64,000 GVW CAB, CHASSIS, DUMP BODY, HYDRAULIC SYSTEM						
***** THIS IS THE END OF RFQ 7011EC10 ***** TOTAL:						

SEE REVERSE SIDE FOR TERMS AND CONDITIONS

SIGNATURE	TELEPHONE	DATE
<i>M. Matheny</i>	304-485-4418	2/15/11
TITLE	FEIN	ADDRESS CHANGES TO BE NOTED ABOVE
CEO	55-032-0770	

WHEN RESPONDING TO RFQ, INSERT NAME AND ADDRESS IN SPACE ABOVE LABELED 'VENDOR'



State of West Virginia
 Department of Administration
 Purchasing Division
 2019 Washington Street East
 Post Office Box 50130
 Charleston, WV 25305-0130

Request for Quotation

RFO NUMBER
 7011EC10

PAGE
 1

ADDRESS CORRESPONDENCE TO ATTENTION OF:
 BUYER 33
 304-558-2402

*709035314 304-485-4410
 MATHENY MOTOR TRUCK COMPANY
 PO BOX 1304
 PARKERSBURG WV 26102-1304

VENDOR

SHIP TO

DIVISION OF HIGHWAYS
 EQUIPMENT DIVISION
 ROUTE 33
 BRUSHY FORK ROAD
 BUCKHANNON, WV
 26201 304-472-1750

DATE PRINTED	TERMS OF SALE	SHIP VIA	F.O.B.	FREIGHT TERMS
01/21/2011	NET 30 DAYS	GROUND	BUCKHANNON, WV	PREPAID
BID OPENING DATE: 02/10/2011		BID OPENING TIME 01:30PM		

LINE	QUANTITY	UOP	CAT. NO.	ITEM NUMBER	UNIT PRICE	AMOUNT
ADDENDUM NO. 3						
THIS ADDENDUM IS ISSUED TO ADDRESS REVISIONS TO THE SPECIFICATIONS, PER THE ATTACHED.						
*****END ADDENDUM NO. 3*****						
0001	1	EA	065-30	64,000 GVW CAB, CHASSIS, DUMP BODY, HYDRAULIC SYSTEM		
***** THIS IS THE END OF RFQ 7011EC10 ***** TOTAL:						

SEE REVERSE SIDE FOR TERMS AND CONDITIONS

SIGNATURE	TELEPHONE	DATE
<i>Mr. Matheny</i>	304-485-4418	02/15/11
TITLE	FEIN	ADDRESS CHANGES TO BE NOTED ABOVE
CEO	55-032-0770	

WHEN RESPONDING TO RFQ, INSERT NAME AND ADDRESS IN SPACE ABOVE LABELED 'VENDOR'

PAGES 6 - 9 OF ADDEDUM NO. 3, STARTING WITH X9.0.8, HAVE BEEN COMPLETED BY THE BODY CO. SHEETS ARE LOCATED BEHIND BODY COMPLIANCE PAGES.

M.J. Mattingly

PREBID ADDENDUM #3
70-11-EC10

OPEN END CONTRACT

64,000 GVW CAB AND CHASSIS, DUMP BODY, AND HYDRAULIC SYSTEM

CHANGES TO BIDDER'S EVALUATION REPORT:

NO CHANGE REQUIRED:

DELIVERY:

X4.2.1 Delivery date of completed representative unit: 120 Calendar Days After Receipt of Purchase Agreement

FROM:

X8.4.2 R.B.M. Ins.Lb. per rail

Have you submitted shop drawings pertaining to frame construction and frame Extension YES NO

TO:

X8.4.2 R.B.M. 3,715,200 Ins./Lb. per rail

NO CHANGE REQUIRED:

X8.6.1 Is engine diesel powered YES NO 12.8 Liter

Peake HP 410 @ 1,800 RPM Electronic

Torque 1,450 lb. ft. at 1,100 RPM

Is engine compliant and certified to meet the US EPA 2010 Emissions Standards without using Federal EPA credits YES NO

DELETE:

X9.0.8 Are there two (2) front frame mounted tow hooks or eyes YES NO

DELETE:

^{2nd}

X9.4.2 Is the hoist of the cross head sleeve twin side lift arms and links design for stability_Y_N

NO CHANGE REQUIRED:

X9.4.4 Does the hoist cylinder have three (3) stages YES NO with

inches of stroke with five (5) inch diameter stage at bottom

YES NO

Manufacturer and part number: _____

FROM:

X9.5.8 Self cleaning safety platform non-skid material located on both sides of dump body, consisting of 1 1/2 inch Bustin hole grip strut installed at bottom of body sides Y N

TO:

X9.5.8 Self cleaning safety platform non-skid material located on both sides of dump body, consisting of 1 1/2 inch grip strut installed at bottom of body sides

YES NO

FROM:

X9.5.12 Is air deflector hood mounted, blue or smoke Y N

Is deflector manufacturers standard width for truck made Y N

Is access to front end hood tilt handle avoided Y N

TO:

X9.5.12 Is air deflector hood mounted, blue or smoke YES NO

Is deflector manufacturers standard width for truck model

YES NO

Deflector size: _____ inches

Is access to front end hood tilt handle avoided

YES NO

FROM:

X9.8.2 Is full height fold down style ladder with 1 1/2 inch Bustin style 16" rungs installed front of body, both Y N

TO:

X9.8.1 Is full height fold down style ladder on one (1) side with 1 1/2 inch grip strut style 16" rungs installed front of body YES NO

FROM:

SEE ADDENDUM #1

X9.9.2 Tailgate hinged at top with flush mount, 1/2 inch flame cut pivots, one (1) inch porke chop type off-set hardware to achieve maximum opening of tailgate, **but have provisions for pivoting at bottom** Y N

TO:

X9.9.2 Tailgate hinged at top with flush mount, 1/2 inch flame cut pivots, one (1) inch pork chop type off-set hardware to achieve maximum opening of tailgate YES NO

DELETE:

SEE ADDENDUM #1 - REMOVED WHEN 9.9.2 WAS REWRITTEN
Top hinge channel with removable, chain tethered keeper pins Y N

NO CHANGE REQUIRED OTHER THAN A MANDATORY NOW

X10.2.1 **Is the normally closed, energized to open, solenoid operated control valve of the cartridge and manifold design to be directly bolted to pump pressure port** YES NO
Is solenoid electrical connection of the Packard "Weatherpack" type with "SO" cable wiring YES NO

FROM:

X10.3.16 Is directional control valve assembly located in a combination tank/valve enclosure assembly to protect the hydraulic tank/valve from elements _Y__N
Reservoir (tank): gallon capacity

TO:

X10.3.16 Is directional control valve assembly located in a combination tank/valve stainless enclosure assembly to protect the hydraulic tank/valve from elements _YES _NO
Reservoir (tank): _____ gallon capacity

FROM:

X10.7.5 Is an internal steel baffle provided within tank _Y__N

TO:

X10.7.5 Is an internal stainless steel baffle provided within tank _YES _NO

FROM:

X10.7.8 Pump supply suction port inch NPT and system return port inch NPT

TO:

X10.7.8 Reservoir supply suction port _____ inch NPT and system return port _____ inch NPT

FROM:

X10.9.6 Are Snap-Tite quick disconnects (manifold mounted) supplied for the spinner 1/2 inch pressure and return lines _Y__N

TO:

X10.9.6 Are Snap-Tite quick disconnects (manifold mounted) supplied for the spinner 1/2 inch pressure and return lines _YES _NO
VH Series or equal Auger/Conveyor _YES _NO



State of West Virginia
 Department of Administration
 Purchasing Division
 2019 Washington Street East
 Post Office Box 50130
 Charleston, WV 25305-0130

Request for Quotation

RFQ NUMBER
 7011EC10

PAGE
 1

ADDRESS CORRESPONDENCE TO ATTENTION OF:
 BUYER 33
 304-558-2402

*709035314 304-485-4410
 MATHENY MOTOR TRUCK COMPANY
 PO BOX 1304
 PARKERSBURG WV 26102-1304

DIVISION OF HIGHWAYS
 EQUIPMENT DIVISION
 ROUTE 33
 BRUSHY FORK ROAD
 BUCKHANNON, WV
 26201 304-472-1750

DATE PRINTED	TERMS OF SALE	SHIP VIA	F.O.B.	FREIGHT TERMS
02/03/2011	NET 30 DAYS	GROUND	BUCKHANNON, WV	PREPAID

BID OPENING DATE: 02/17/2011 BID OPENING TIME 01:30PM

LINE	QUANTITY	UOP	CAT NO	ITEM NUMBER	UNIT PRICE	AMOUNT
				ADDENDUM NO. 4		
				THIS ADDENDUM IS ISSUED TO EXTEND THE BID OPENING DATE FROM:		
				02/10/2011 AT 1:30 PM		
				TO		
				02/17/2011 AT 1:30 PM		
				*****END ADDENDUM NO. 4*****		
0001	1	EA	065-30	64,000 GVW CAB, CHASSIS, DUMP BODY, HYDRAULIC SYSTEM		
				***** THIS IS THE END OF RFQ 7011EC10 ***** TOTAL:		

SEE REVERSE SIDE FOR TERMS AND CONDITIONS

SIGNATURE	TELEPHONE	DATE
<i>M.J. Matheny</i>	304-485-4418	02/15/11
TITLE	FEIN	ADDRESS CHANGES TO BE NOTED ABOVE
CEO	55-032-0770	

WHEN RESPONDING TO RFQ, INSERT NAME AND ADDRESS IN SPACE ABOVE LABELED 'VENDOR'



State of West Virginia
 Department of Administration
 Purchasing Division
 2019 Washington Street East
 Post Office Box 50130
 Charleston, WV 25305-0130

Request for Quotation

RFO NUMBER
7011EC10

PAGE
1

ADDRESS CORRESPONDENCE TO ATTENTION OF:
BUYER 33
304-558-2402

VENDOR

*709035314 304-485-4410
 MATHENY MOTOR TRUCK COMPANY
 PO BOX 1304
 PARKERSBURG WV 26102-1304

SHIP TO

DIVISION OF HIGHWAYS
 EQUIPMENT DIVISION
 ROUTE 33
 BRUSHY FORK ROAD
 BUCKHANNON, WV
 26201 304-472-1750

DATE PRINTED	TERMS OF SALE	SHIP VIA	F.O.B.	FREIGHT TERMS
02/16/2011	NET 30 DAYS	GROUND	BUCKHANNON, WV	PREPAID
BID OPENING DATE: 02/24/2011		BID OPENING TIME 01:30PM		

LINE	QUANTITY	UOP	CAT. NO.	ITEM NUMBER	UNIT PRICE	AMOUNT
001	1	EA	065-30	64,000 GVW CAB, CHASSIS, DUMP BODY, HYDRAULIC SYSTEM		
ADDENDUM NO. 5 THIS ADDENDUM IS ISSUED TO EXTEND THE BID OPENING DATE FROM: 02/17/2011 AT 1:30 PM TO 02/24/2011 AT 1:30 PM ***** ADDENDUM NO. 5 ***** ***** THIS IS THE END OF RFQ 7011EC10 ***** TOTAL:						

SEE REVERSE SIDE FOR TERMS AND CONDITIONS

SIGNATURE <i>My Matheny</i>	TELEPHONE 304-485-4418	DATE 2-15-11
OFFICE CEO	FEIN 55-032-0770	ADDRESS CHANGES TO BE NOTED ABOVE

WHEN RESPONDING TO RFQ, INSERT NAME AND ADDRESS IN SPACE ABOVE LABELED 'VENDOR'



State of West Virginia
 Department of Administration
 Purchasing Division
 2019 Washington Street East
 Post Office Box 50130
 Charleston, WV 25305-0130

Request for Quotation

RFQ NUMBER
 7011EC10

PAGE
 1

ADDRESS CORRESPONDENCE TO ATTENTION OF
 BUYER 33
 304-558-2402

VENDOR

*709035314 304-485-4410
 MATHENY MOTOR TRUCK COMPANY
 PO BOX 1304
 PARKERSBURG WV 26102-1304

SHIP TO

DIVISION OF HIGHWAYS
 EQUIPMENT DIVISION
 ROUTE 33
 BRUSHY FORK ROAD
 BUCKHANNON, WV
 26201 304-472-1750

DATE PRINTED: 02/23/2011	TERMS OF SALE: NET 30 DAYS	SHIP VIA: GROUND	F.O.B. BUCKHANNON, WV	FREIGHT TERMS: PREPAID
-----------------------------	-------------------------------	---------------------	--------------------------	---------------------------

BID OPENING DATE: 03/10/2011 BID OPENING TIME: 01:30PM

LINE	QUANTITY	UOP	CAT NO	ITEM NUMBER	UNIT PRICE	AMOUNT
ADDENDUM NO. 6						
THIS ADDENDUM IS ISSUED TO:						
1.) MAKE CHANGES TO SPECIFICATIONS PER THE ATTACHED.						
2.) EXTEND THE BID OPENING DATE FROM						
02/24/2011 AT 1:30 PM						
TO						
03/10/2011 AT 1:30 PM						
*****END ADDENDUM NO. 6*****						
0001	1	EA		065-30		
64,000 GVW CAB, CHASSIS, DUMP BODY, HYDRAULIC SYSTEM						
***** THIS IS THE END OF RFQ 7011EC10 ***** TOTAL:						

SEE REVERSE SIDE FOR TERMS AND CONDITIONS

SIGNATURE <i>M. Matheny</i>	TELEPHONE 304-485-4418	DATE 3/4/11
TITLE CEO	FEIN 55-032-0770	ADDRESS CHANGES TO BE NOTED ABOVE

WHEN RESPONDING TO RFQ, INSERT NAME AND ADDRESS IN SPACE ABOVE LABELED 'VENDOR'

ADDEDUM NO. 6 HAS BEEN COMPLETED BY BODY CO.
SEE ADDEDUM NO. 6 AS COMPLETED BY THE BODY CO.
LOCATED BEHIND BODY COMPLIANCE SHEETS.

M. J. Mathews

ADDENDUM #6
70-11-EC10

OPEN END CONTRACT

64,000 GVW CAB AND CHASSIS, DUMP BODY, AND HYDRAULIC SYSTEM

CHANGES TO BIDDER'S EVALUATION REPORT:

NO CHANGE REQUIRED: Change of Bid Opening Date

FROM:

X9.0.3 Front body bulkhead: ___ inch AR400 steel ___ PSI yield strength

TO:

X9.0.3 Front body bulkhead: _____ inch _____ steel

FROM:

X9.2.1 Floor: ___ inch AR400 ___ PSI yield strength with ___ degree knee brace welded to floor

TO:

X9.2.1 Floor: _____ inch _____ steel with _____ degree knee brace welded to floor

Is body crossmemberless type _____ YES _____ NO

FROM:

X9.2.2 Sides: ___ Gauge AR400 ___ PSI yield strength steel thickness

TO:

X9.2.2 Sides: _____ Gauge _____ steel thickness

FROM:

X9.2.3 Tailgate Plate: ___ inch AR400 ___ PSI yield strength steel

TO:

X9.2.3 Tailgate Plate: _____ inch _____ steel

WEST VIRGINIA DEPARTMENT OF TRANSPORTATION
DIVISION OF HIGHWAYS
EQUIPMENT DIVISION

BIDDER'S EVALUATION REPORT

PROCUREMENT SPECIFICATIONS FOR OPEN END CONTRACT
NO. 377-2-G
NOVEMBER 2010

64,000 GVW CAB AND CHASSIS, DUMP BODY, AND HYDRAULIC SYSTEM

NOTE TO BIDDER: Procurement Specification No. 377-2-G, Paragraph 2.0 recommends the completion and submittal of this Report with your bid. Purpose of this Report is to enable the West Virginia Division of Highways Evaluation Committee to make full and fair evaluation of the bid. Addendums in order, along with a summary of exception as a separate attachment, should be with Bidder's Evaluation Report.

FAILURE TO SUBMIT THIS REPORT, COMPLETE IN ITS ENTIRETY, MAY SUBJECT THE BIDDER TO DISQUALIFICATION.

Reference Requisition No.: 7011EC10

Bidder's Name: MATHENY MOTOR TRUCK COMPANY

Address: 3RD & ANN STS. PO BOX 1304, PARKERSBURG, WV 26102-1304

Telephone Number: 304-485-4418

Years Bidder has been registered to do business with the State of West Virginia: 89 YRS.

Years Company has been an authorized dealer for proposed unit: <1 YRS.

X3.2 Have you complied with all mandatory specifications? YES NO.

X4.2 DELIVERY:

X4.2.1 Delivery date of completed representative unit: 120 Calendar Days After
Receipt of Purchase Agreement

X4.2.2 Delivery date of balance of completed units: 180 Calendar Days After Receipt of
Purchase Agreement

X5.0 AWARD CRITERIA;**X5.1 Price per unit:**\$139,687.00 per unit**X6.0 SPECIFICATIONS - GENERAL****X6.1 Manufacturer, model, series, and date of manufacture of proposed unit:**FREIGHTLINER, 114SD, M2, 2nd - 3rd QTR 2011Is descriptive literature, fully describing proposed unit attached to your bid? YES NO

If not, why? _____

X6.2 Will the required number of service manuals, and complete parts list be delivered to the Equipment Division at Buckhannon upon completion of delivery of total units? YES NO**Will the required Equipment Preventive Maintenance Form (Section X6.2 of Bidders Evaluation Report) be provided upon inspection of the pilot unit?** YES NO

X6.2
2-10-00

EQUIPMENT PREVENTATIVE MAINTENANCE QUESTIONNAIRE

THIS FORM MUST BE COMPLETED IN ITS ENTIRETY BY SUCCESSFUL BIDDER OR MANUFACTURER'S TECHNICAL REPRESENTATIVE PRIOR TO DELIVERY OF PILOT MODEL TO THE WVDOH.

DESCRIPTION: _____ MAKE: _____

MODEL: _____ YEAR: _____ PURCHASE AMOUNT: _____

ENGINE: MAKE: _____ MODEL: _____ FUEL TYPE: _____

HORSEPOWER: _____ CYLINDER: _____ ENGINE SERIAL: _____

COOLING SYSTEM CAPACITY: _____

BELTS:	DESCRIPTION:	PART NUMBERS:
	_____	_____
	_____	_____

GVW: _____ AXLE CAPACITY: FRONT: _____ REAR: _____

TIRES: FRONT MAKE & SIZE: _____

REAR MAKE & SIZE: _____

DIMENSIONS OF UNIT: LENGTH: _____ WIDTH: _____ LENGTH: _____

VENDOR CONTACT PERSON: _____ PHONE: _____

PARTS:

BATTERY MAKE: _____	MODEL: _____	CCA: _____
TOP OR SIDE POST: _____	DIMENSIONS: LENGTH _____	WIDTH _____ HEIGHT _____
SPARK PLUGS OR FUEL INJECTORS MAKE: _____	PART # _____	
FUEL PUMP OR INJECTION PUMP MAKE: _____	MODEL: _____	
ALTERNATOR MAKE: _____	PART #: _____	
STARTER MAKE: _____	PART #: _____	
TURBO CHARGER MAKE: _____	PART #: _____	
TRANS. MAKE: _____	MODEL: _____	AUTO/MANUAL: _____
HYDRAULIC PUMP MAKE: _____	MODEL: _____	

FILTERS	MAKE	PART NO.	LUBRICANT	MANUFACTURER TYPE
OIL	_____	_____	ENGINE	_____
AIR INNER	_____	_____	TRANSMISSION	_____
AIR OUTER	_____	_____	POWER STEERING	_____
FUEL PRIMARY	_____	_____	HYDRAULIC	_____
FUEL SECONDARY	_____	_____	DIFFERENTIALS	_____
COOLANT	_____	_____	BRAKE FLUID	_____
HYDRAULIC	_____	_____	COOLANT	_____
OTHER	_____	_____	OTHER	_____

X6.3 TRAINING:

Will training seminar be conducted on Preventive Maintenance, Operator and Mechanic Training
 YES NO

Will you conduct training with each purchase order against this open end contract?
 YES NO

Will training be conducted within 2 working days from the delivery of the pilot unit on the individual purchase order?
 YES NO

If NO, explain time frame _____

Will an Operator's Manual be furnished directly to Training Academy prior to the delivery of the pilot?
 YES NO

X6.4 If you are the successful vendor, will you furnish all training aids, i.e., videos, projectors, required in conducting the training?
 YES NO

X6.4.1 Will all manuals, booklets, etc. explaining preventive maintenance, operator procedures, and service schedule be delivered with each unit?
 YES NO
 If NO, explain _____

X6.5 WARRANTY AND SERVICE POLICY

Will the warranty and service you provide comply with all areas as stated in Section 6.5 of specifications
 YES NO

Is warranty literature attached?
 YES NO

Is a minimum two (2) year bumper to bumper basic parts and labor warranty excluding abuse and normal wear items included?
 YES NO

Describe:

SEE ATTACHMENT

X6.5 WARRANTY AND SERVICE POLICY QUESTIONNAIRE**THIS FORM MUST BE COMPLETED IN ITS ENTIRETY AND SUBMITTED WITH YOUR BID.**

(If additional lines are needed, make copies of form.)

1. Define the terms of the standard warranty. If not offered, so state. (Attach copy)

PER 6.5: 2 YEAR BUMPER TO BUMPER ON CHASSIS & BODY

3 YEAR UNLIMITED MILES ENGINE WARRANTY

SEE ATTACHMENT

2. Define warranty service to be performed at DOH facilities and warranty service to be performed at manufacturer's representative facility. List name and location of manufacturer's representative.

DOH CAN PERFORM WARRANTY WORK AS LONG AS THEY MEET FREIGHTLINER'S

TRAINING, TOOLING & WARRANTY PROCEDURES.

MANUFACTURER'S REPRESENTATIVE: JOE MANZIONE, CRANBERRY TWN, PA

3. List locations for parts inventories that are within the State of West Virginia. Also, list availability levels, if known.

MATHENY MOTOR TRUCK CO., MINERAL WELLS, WV - \$1.8M

MCCOY FREIGHTLINER, WAYNE COUNTY, WV - NOT KNOWN

4. During the term of warranty, list the guarantee discount to manufacturer's published list price for parts that bidder will sell the parts to owner.

A.	Terms: Net 30	Manufacturer's published list price less:	<u>25</u>	% discount
B.	Terms: Net 60	Manufacturer's published list price less:	<u>20</u>	% discount
C.	Terms: Net 90	Manufacturer's published list price less:	<u>15</u>	% discount

5. During the term of warranty, will all manufacturers or engineering improvements be submitted to Division of Highways? x YES NO

6. During the term of warranty, list the guaranteed rates charged for repair to the unit.

A. Shop Rate \$ 90.00 per mechanic hourB. Travel Time Charge \$ 90.00 per mechanic hour
(Specify if one-way) _____; port to port x C. Mileage Charge \$ NONE per vehicle mile
(Specify if one-way) _____; port to port _____D. Field Mechanic Rate \$ 90.00 per mechanic hourE. Specify period of time that prices are in effect: 12 MONTHSF. Surcharge for miscellaneous items: 15 %

X6.6 EVALUATION COMMITTEE REQUIREMENTS

Is all component specifications, product literature, component models provided for Evaluation Committee bid determination? YES NO

X6.7 Will all parts, equipment, accessories, material, design and performance characteristics not specified herein, but which are necessary to provide a complete unit, be furnished with the unit and conform in strength, quality of material, and quality of workmanship to those which are advertised and provided to the market in general by the unit industry?
 YES NO

X6.7.1 Are all parts and accessories adequate and regularly supplied as standard to be included except those which may be duplications of specifications herein, and except these by specification are not to be furnished?
 YES NO

X6.7.2 Are all standard safety features that are required by Federal and State statutes of law included?
 YES NO

X7.0 SPECIFICATIONS OF THE QUOTED UNIT

The bidder should complete the following schedule in order for the Division to compare the actual bid unit to the specifications. Should the bidder except a requirement, then such exception may be only on the basis that such feature is not offered by the manufacturer. The Division will have the sole discretion as to whether the bidder's substitution meets the requirements of the specifications.

X8.0 SPECIFICATIONS - CAB & CHASSIS

Manufacturer: FREIGHTLINER Model: M2 114SD

X8.1 GVWR rating: 64,000 lbs.

X8.2 Cab to axle dimension: 124 inches usable

X8.2.1 After frame length 63 inches

X8.3 Wheelbase: 238 inches

Is it a set forward axle design for snowplow application for various plows
 YES NO

X8.3.1 Are the wheelbase and CA dimensions adjusted to provide optimum legal weight distribution
 YES NO

- X8.3.2 Bumper to back of cab: 114 inches dimension excluding frame extension**
- X8.4 Frame: Will the manufacturer provide a frame that meets or exceeds all Federal requirements for GVWR specified that extends forward beyond the grille a minimum of 14 inches.**
 YES NO
- X8.4.1 Frame material: 120,000 PSI yield strength**
Is frame extension "parent rail" material YES NO
- X8.4.2 R.B.M. 3,715,200 Ins./Lb. Per rail**
Have you submitted shop drawings pertaining to frame construction and frame extension
 YES NO
- X8.4.2.1 Where engine and radiator adjustments are required N.A. in lb. per rail (RBM)**
- X8.4.3 Main frame and any required liners straight channel** YES NO
Or offset channel YES NO full length
- X8.4.4 Is minimum frame RBM approved by manufacturers Engineering Department**
 YES NO
- X8.4.5 Does front frame accommodate the Department's standard hydraulic PTO shaft and pump, and the plow frame** YES NO
- X8.4.5.1 Easy service accessibility** YES NO
- X8.5 Cab: Is cab manufacturers standard steel, aluminum, and/or fiberglass** YES NO
Is hood tilt hood and fenders either steel and/or fiberglass and provided with rear air bag suspension
 YES NO
- X8.5.1 Cab door locks, both doors, keyed alike** YES NO
- X8.5.2 Dual sun visors** YES NO
- X8.5.3 Arm rests, both sides** YES NO
- X8.5.4 Seats: Fully adjustable air ride high back with head rest, cloth covered both left hand and right hand sides**
 YES NO
- Clearance between seats: 20 inches**
- X8.5.5 Floor Mats: Rubber floor mats throughout cab area with non-absorbent backing under the mats**
 YES NO
- X8.5.6 Turn Signals: Manufacturers standard with hazard warning switch**
 YES NO
- X8.5.7 Heater and defroster: Fresh air type, heaviest duty** YES NO

- X8.5.8 Windshield wipers and washers: Manufacturer's heaviest duty "artic type" with intermittent feature with manufacturers largest reservoir filled with antifreeze type solvent
 YES NO
- X8.5.9 Instruments: All instruments dash mounted except where specified
 YES NO
- X8.5.9.1 Coolant, oil pressure gauges, to have both dial type readout and either an audible or visual alarm to warn operator when safe operating conditions are exceeded
 YES NO
- X8.5.9.2 Voltmeter or ammeter YES NO
- X8.5.9.3 Engine RPM tachometer YES NO
- X8.5.9.4 Speedometer with odometer YES NO
- X8.5.9.4.1 Provisions for dual speedometer leads made available**
 SEE EXCEPTION REPORT YES NO
- X8.5.9.5 Primary air pressure gauge YES NO
- X8.5.9.6 Auxiliary air pressure gauge YES NO
- X8.5.9.7 Air filter manufacturers heaviest duty dual element type that meets all requirements of extended engine warranty YES NO
- X8.5.9.8 If unit is equipped with front air intake, is a cable control valve to enable operator to divert air intake to engine compartment during plowing application provided**
 YES NO THIS UNIT DOES NOT HAVE FRONTAL AIR INTAKE.
- X8.5.9.9 Air filter restriction indicator gauge dash mounted** YES NO
- X8.5.9.10 Engine hourmeter (controlled by engine operation, not by key switch)
 YES NO
- X8.5.9.11 Fuel level reading YES NO
- X8.5.9.12 Parking brake to be dash controlled with indicator light YES NO
- X8.5.9.13 Is the sound/weather insulation package the manufacturer's best for proposed cab
 YES NO
- X8.5.9.14 Outside temperature control with in cab digital read out and accomplished without use of mirrors**
 YES NO
- X8.5.10 Rearview Mirrors:
- X8.5.10.1 Mirrors are West Coast type power adjustable with convex spot mirror
 YES NO
 Size: 16.75" x 5.1" PLUS CONVEX MIRROR

- X8.5.10.2 Both mirrors heated type with stainless steel YES NO or Composite YES NO or aluminum YES NO hardware, heads, and fasteners
- X8.5.11 Grab Handle: Right hand and left hand sides, internal of external mounting to rear of door opening YES NO
- If inside handles are featured, one (1) outside, left mounted grab handle with non-slip insert for bed aggregate inspection is furnished YES NO**
- X8.5.12 Air horns, with snow shields, cab mounted with adequate clearance for future installation of body cab shield YES NO
- X8.5.13 Unit includes lockable hand operated throttle control or electronic control for idle up and idle down for hydraulic flow rate YES NO
- X8.5.14 Manufacturer will provide for stationary grille or grille with cutout area to allow tilt hood to clear snow plow mount YES NO
- Stone/gravel guard provided YES NO
- X8.5.15 Air conditioning: Manufacturers standard package for model bid. "APADS" to specified air condition system SEE EXCEPTION REPORT YES NO
- X8.5.16 Radio: AM/FM stereo with weatherband radio feature YES NO
- X8.5.17 Glass: Manufacturers tinted safety glass (all locations) YES NO
- X8.5.17.1 Dual power windows YES NO
- X8.5.18 Manufacturers engine cover or dash mounted extended two (2) cup drink holder YES NO
- X8.5.19 Front mudflaps manufacturers standard for unit YES NO
- X8.5.20 Emergency triangle warning kit, with hold down fastened in cab
 Manufacturers: GROTE OR 71422 YES NO
 STIMPSONITE Part No. 130
 OR KING JAMES CO. 1005
- X8.5.21 Manufacturers tilt steering column with cruise control feature or provide locking hand operated throttle steering wheel 18 inches diameter YES NO
- X8.5.22 Fire extinguisher - rechargeable with vehicle mount. Mounted in cab for easy and quick access
 YES NO
 Manufacturer: KIDDE Part No. 466225-01
- X8.5.23 Accessories not indicated above but advertised as standard equipment provided
 YES NO

X8.5.24 If successful vendor, will you provide complete list of all filters required for normal maintenance X YES NO

X8.6 Engine: Has engine manufacturer made provisions for front mounted hydraulic pump to crankshaft X YES NO

X8.6.1 Is engine diesel powered X YES NO 12.8 Liter

Peak HP 410 @ 1,800 RPM Electronic Torque 1,450 lb. ft at 1,100 RPM
NON PEAK HP 400 @ 1,600 SEE EXCEPTION REPORT

Is engine compliant and certified to meet the US EPA 2010 Emissions Standards without using Federal EPA credits X YES NO

X8.6.1.2 One piece and waterproof electrical cable from heater to plug, location - left side under driver door X YES NO

X8.6.1.3 In line fuel heater with thermostatically controlled by pass maintain #2 diesel fuel temperature above cloud point before diesel fuel passes through the filter X YES NO

Manufacturer: ARTIC FOX Model: AFXC406

X8.6.1.3.1 Is engine fuel system equipped with primer pump X YES NO

X8.6.1.4 Exhaust:

X8.6.1.4.1 Single vertical exhaust pipe with underbody muffler that will meet all Federal noise abatement requirements; exhaust to the passenger (right) side of unit X YES NO

X8.6.1.4.2 Tail pipe shielded or insulated to protect personnel from burns when entering or exiting the cab X YES NO

Shield 180 degrees to 360 degrees and of non-rustable material such as stainless steel or aluminum X YES NO

Manufacturer: BURGAFLEX

X8.6.1.4.3 Exhaust pipe with rain cap or exhaust turn out X YES NO

X8.6.2 Engine Brake:

Manufacturer: JACOBS Model: 128-002

X8.6.3 Engine components facing wheel areas, on both sides, and areas to the rear of wheels shielded by means of rubber skirts supported by easily removable steel rods X YES NO

X8.7 Cooling System: The cooling system capable of maintaining engine temperature within the manufacturer's recommended range during continuous operation X YES NO

- X8.7.1 **The system incorporates a thermostat and bypass for warm up and filled with permanent type extended life or equal antifreeze rated to a -30 degree F or lower** YES NO
- X8.7.2 Is the largest factory available engine cooling capacity compatible with engines and transmission referenced and for continuous high engine output under extreme temperatures and/or operating conditions due to prolonged snow plowing operations in low gears YES NO
- X8.7.3 Unit is fitted with provisions for visually monitoring coolant with necessitating removal of the cap from the radiator or expansion tank YES NO
- X8.7.4 **Radiator mounting provides adequate clearance to facilitate the installation of a crankshaft driven PTO drive shaft** YES NO
- X8.7.5 **The distance between the extreme tip of the radiator fan blade and the centerline of the crankshaft** 5 inches to insure adequate clearance for PTO drive shaft
- X8.7.6 Radiator screen guard to protect radiator from foreign objects YES NO
- X8.8 Fuel Tank:
- X8.8.1 Safety type aluminum fuel tanks per requirements of FMVSS YES NO
- X8.8.2 Single aluminum fuel tanks: YES NO Capacity (usable) 100 US gallons
Frame mounted YES NO
- X8.8.3 Driver and passenger entrance steps - grated self cleaning safety step YES NO
- X8.8.3.1 All edges banded on the outer perimeter YES NO
- X8.8.3.2 Top of first step 15.7 inches above ground
- X8.8.4 System top draw and top return line YES NO
SEE EXCEPTION REPORT
- X8.8.5 **Does fuel system meet all 2010 emission standards** YES NO
- X8.9 Electrical System:
- X8.9.1 Type: Manufacturer's 12 volt negative ground system with manufacturers radio interference suppression YES NO
- X8.9.1.1 Circuit breaker equipped in easily accessible location, weatherproof YES NO
- X8.9.2 **Number of batteries:** 4
- 2500 CCA heavy duty maintenance free batteries** YES NO
- Reserve capacity:** 780 minutes

BATTERIES ARE 4,400 CCA

- X8.9.3** Alternator capacity: 160 AMP with internal regulator YES NO
- X8.9.4** Wiring: Heavy duty hypalon type in heavy duty sheathing, bundled with lacing cords or non metallic tie straps YES NO
- X8.9.5** **Lighting: Provisions made available for all required lighting on completed unit (Number, location, and color) to conform to WVMV Code** YES NO
- X8.9.6** Auxiliary snow plow/salt spreader lighting package:
- X8.9.6.1** Provisions in left rear corner of cab for manufacturers approved wiring and weather proof disconnect plug to operate the following lights on truck mounted chemical spreader YES NO
- Manufacturer and model: APEX MODEL FC154001401 & FC154201415
1. One sealed beam flood lamp YES NO
2. Left and right combination brake/turn and tail lights YES NO
3. One strobe warning light YES NO
- X8.9.7** Provisions are made for manufacture approved wiring and weatherproof disconnect plug in line six (6) pin connector with approximately three (3) foot "pigtail" to operate combination left and right turn/park lights/auxiliary headlights YES NO
- Manufacturer and model: WEATHER PAC 1530027
- X8.9.7.1** Provisions for weatherproof disconnect plug located at lower left front grille-bumper area YES NO
- All wiring connections weatherproof with wiring encased in wire looms YES NO
- X8.9.7.2** 7-way trailer connection light socket mounted at rear of truck frame YES NO
- Manufacturer and model: PHILLIPS (J560) 15720
- X8.10** Power Train Overview:
- Lubricants for front axle hubs and differentials, automatic transmission, transfer cases, and all rear differentials meet or exceed all appropriate MIL and SAE specifications for synthetic lubricants and have all plugs identified as synthetic or painted red** YES NO
- X8.10.1** Transmission: ALLISON 4500 RDS 6-SPEED
Manufacturer transmission oil cooler YES NO
- X8.10.1.1** Does transmission torque capacity meet specified engine torque YES NO

X8.11 Driveline:

X8.11.1 Manufacturer: MERITOR Model: 18N MAIN; 17T INTERAXLE

X8.12 Rear Axle:

X8.12.1 Manufacturer: MERITOR Model: RT-46-160P

X8.12.2 Unit equipped with four (4) wheel dual reduction carriers equipped with driver controlled main locking differential in forward and rear axle that is manually controlled and **have traction control device via ABS system, ATC or equal** x YES NO

Equipped with all wheel lock up 0-25 MPH driver controlled and above 25 MPH ATC will control x YES NO

X8.12.3 Ratio: Does gear ratio allow vehicles to be capable of a top speed of 70 MPH x YES NO

X8.12.4 Specify housing type IRON AXLE CARRIERX8.12.5 Rear wheel seals: CHICAGO RAWHIDEX8.12.6 Drain plug, magnetic x YES NO

X8.13 Front Suspension:

X8.13.1 Capacity at ground each front spring: 10,000 lbs.; total spring capacity 20,000 lbs.

X8.13.2 Front spring pins or bearings/bushing furnished with 360 degree grease grooves to insure adequate lubricant penetration x YES NO

X8.13.3 Spring hangers heavy castings with sufficient pin and bearing surface to render trouble free service x YES NO

X8.14 Rear Suspension:

Manufacturer: HENDRICKSON Model: RT463

X8.15 Front Axle:

X8.15.1 Capacity: 18,000 lbs.

X8.15.1.1 Front axle, drag links, and tie rods have grease zerks installed x YES NO

X8.15.2 Heavy duty shock absorbers x YES NO

X8.15.3 Front wheel seals oil lubricated type x YES NO
Manufacturers: CHICAGO RAWHIDE

X8.15.4 Adequate tire clearance at maximum turning angles x YES NO

X8.16 Brakes:

X8.16.1 Type: Full air, with manufacturers ABS in compliance with most current FMVSS requirements
 YES NO

X8.16.2 Compressor:

Manufacturer: BW Model: BA-921 Cubic ft. 19.0

X8.16.3 Service Brake Size:

X8.16.3.1 Front: 16.5 inch x 6 inch
 S Cam YES NO or power front disc brake system YES NO

X8.16.3.2 Quick change type single YES NO or
 double anchor pin if drum type brakes are furnished YES NO

X8.16.3.3 Rear: 16.5 inch x 7 inch
 S cam with quick change type single YES NO or
 double pin YES NO

X8.16.4 Drum brakes have automatic slack adjusters and clearance sensing type only, with adjustment on application of brake
 YES NO

X8.16.5 Parking Brake: Rear wheel spring type YES NO

Manufacturer: HALDEX Model: GOLDSEAL- severe service spring brakes

X8.16.5.1 Parking brake provides modulated emergency braking via the foot valve in the event of a rear service system failure
 YES NO

X8.16.6 Air dryer with heater above road surface: 21⁺ inches

Manufacturer: BW Model: AD-9 with spin on desiccant cartridge
 YES NO

X8.16.6.1 All electrical connectors for drain valve and air dryer covered with heat shrink material or have sealed connections
 YES NO

X8.16.7 Manufacturer's standard air tanks for service brakes; auxiliary tank for parking brake
 YES NO

X8.16.8 Low air pressure warning light and buzzer
 YES NO

X8.16.9 Rear service brake chambers and spring brake chambers mounted to provide adequate clearance for tire chains and backing into bituminous paving machines
 YES NO

X8.16.10 Brake dust covers installed on all wheels
 YES NO

X8.16.11 Unit equipped with hand control valve, tractor protection valve, with provisions for installation of glad hands at rear of truck to enable unit to pull air brake operated equipment trailer
 YES NO

X8.17 Tires and Wheels:

X8.17.1 Is truck equipped with hub piloted steel disc wheels for tubeless tires
 YES NO

X8.17.2 Wheel end equipped with outboard cast brake drums, and 15 degree tubeless steel wheels, hub piloted, 10 hole - 285.75mm bolt circle with 22mm two piece flange nuts
 YES NO

X8.17.3 Front:

X8.17.3.1 Wheels:

Size: 22.5" x 9.0"

10 hole - 285.75mm bolt circle with 220mm bore YES NO

Tubeless steel disc wheel rated at 10,000 lbs. at a maximum inflation pressure of 130 PSIG
 YES NO

Manufacturer: ACCURIDE Part No. 29039

X8.17.3.2

Tires:

Size: 315/80R22.5 Ply: 20

X8.17.4 Rear:

X8.17.4.1 Wheels:

Size: 22.5" x 8.25"

10 hole - 285.75mm bolt circle with 220mm bore YES NO

Tubeless steel disc wheel rated at 7500 lbs. at a maximum inflation pressure of 120 PSIG
 YES NO

Manufacturer: ACCURIDE Part No. 28828

X8.17.4.2

Tires:

Size: 11R22.5

X8.17.4.3 Does the dual rear wheel/tire assembly have clearance between the tires, which permits the use of dual tire chains
 YES NO

X8.17.5 Wheel guard Separators YES NO

X8.17.6 Tires: radials YES NO

Manufacturer: GOODYEAR Front Tire: G291

Manufacturer: GOODYEAR Rear Tire: G282

X8.18 Steering:

X8.18.1 Power steering: Dual integral YES NO or single integral type YES NO hydraulic power steering with right wheel power assist cylinder YES NO

- X8.18.2 Steering system:
 Manufacturer: TRW Model: THP-60
- X8.18.3 Hydraulic supply pump:
 Vane type YES NO or roller type YES NO with sufficient
 oil flow to permit one (1) steering wheel revolution per second with front axle loaded
 to rated capacity with plow on, in a "park" condition YES NO
 Manufacturer: TRW Model: EV SERIES
- X8.18.4 Is the pump the integral filter type unit YES NO
 X8.18.5 Power steering reservoir: Remote mounted YES NO
 Capacity: 4 qt. incorporating a filter which is easy to remove and replace
 YES NO
- X8.18.6 The remote filter factory mounted, certified, and engineering approved in conjunction with the
 appropriate pump YES NO
- X8.19 All features advertised by manufacturer as "standard features" provided if not specifically
 addressed within YES NO**
- X8.20 Paint:
- X8.20.1 Cab exterior and interior color manufacturers standard white YES NO
 X8.20.2 Grille: BLACK WITH BRIGHT FINISH
 X8.20.3 Wheel paint: PER BID SPECIFICATIONS
 Power coated but gray top coat YES NO
- X8.20.4 Describe proposed method of painting and prepping:
PER BID SPECIFICATIONS
- X8.21 Detail/Decorative Stripes with Logo:
- X8.21.1 Width: 4 inches
 X8.21.2 Will you comply with WVDOH logo area YES NO
 X8.21.3 Does conspicuity striping material provided meet requirements of Section 8.21.3 through 8.21.8 of
 specification section? YES NO
- X8.22 Does unit offered meet or exceed "Occupational Safety and Health Act of 1970"
 YES NO**
- X8.23 Does unit conform to the advertising guidelines YES NO**

X8.24 Preventive Maintenance

X8.24.1 Will a preventative maintenance and operator's training seminar be provided
 YES NO

X8.24.2 Will booklets and pamphlets be furnished to be used by the operators
 YES NO

X8.24.3 Will you furnish all training aids; i.e. videos, projectors, etc. required in conducting the training
 YES NO

X9.0 SPECIFICATIONS OF THE DUMP BODY

The bidder should complete the following schedule in order for the Division to compare the actual bid unit to the specifications. Should the bidder except a requirement, then such exception may be only on the basis that such feature is not offered by the manufacturer. The Division will have the sole discretion as to whether the bidder's substitution meets the requirements of the specifications.

Bidder: SEE NEXT PAGE

Address: _____

Telephone Number: _____

Years company has been an authorized dealer for proposed unit: _____ years

Manufacturer, model, series, and date of manufacture of proposed Dump body:

Is descriptive literature full describing proposed dump body attached to your bid proposal? YES NO

If NO, refer to specification statement Section 6.6

When will required number of operating manuals, service manuals, and complete parts list be delivered to the Equipment Division at Buckhannon? _____ prior to deliver of unit or _____

Dump body warranty: _____

X9.0.1 Water Level of dump body: _____ cu yd

X9.0.2 Will side board pockets and tailgate height provide additional capacities of 2-5 cu. yd.
 YES NO

"EXCEPTIONS TO SPECIFICATIONS"

RFQ NUMBER 7011EC10

West Virginia Division of Highways

Bidder: MATHENY MOTOR TRUCK COMPANY

- X8.5.20 Emergency triangle warning kit requests KD610-464S, KD Lamp or equal. I am providing Grote 71422 or Stimpsonite 130 or King James Co. 1005. These other three manufacturer's are "or equal". The reason for the three suppliers is that these kits are not readily available so we are forced to use three suppliers.
- X8.5.9.4.1 Provision for dual speedometer leads for body company are located in the chassis supplied body company component interface junction block.
- X8.5.10.1 Bid specs call for a mirror size of 7" X 16" with convex mirror. I am supplying a 5.1" X 16.75" mirror with convex mirror.
- X8.5.15 The Freightliner air conditioning diagnostic system is part of the complete chassis diagnostic system. This system is newer and more accurate than "APADS".
- X8.6.1 Bid spec requests a 395 hp @ 1700 rpm. I am supplying a 410 hp @ 1800 rpm. My hp at 1700 rpm is 400 hp.
- X8.6.1.3 Included in my bid is a Artic Fox Model AFXC 406 in tank fuel heater. Bid request's a Zero Start Model 820-8751 & thermostat Model 820-8786 inline fuel heater.

- X8.6.1.4.2 Our tailpipe shield is supplied by Burgaflex which is an or equal to Riker.
- X8.8.4 My fuel tank system is a side draw system. Bid call for a top draw.
- X8.9.6.1 Bid calls for Cole Hersee No. 12081 & I am providing Apex FC154001401 & FC154201415. Apex is an "or equal" and the reason for the two numbers is that I am supplying the chassis and the body plug.
- X8.9.7 Bid request is for Weather Pac 12010975 and I am supplying the Weather Pac 1530027 which is an "or equal" and is designed for our chassis.
- X8.9.7.2 Bid request is for a Cole Hersee No. 12081 and I am providing an "or equal" Phillips No. 15720 which is identical to the Cole Hersee No. 12081.
- X8.12.5 Bid request is for Stemco or equal and Chicago Rawhide is an "or equal".
- X8.15.3 Bid request is for Stemco or equal and Chicago Rawhide is an "or equal".
- X8.16.5 Bid request is for MGM TR-TS parking brakes and the Haldex Goldseal is an "or equal".

X8.24 Preventive Maintenance

X8.24.1 Will a preventative maintenance and operator's training seminar be provided
_____ YES _____ NO

X8.24.2 Will booklets and pamphlets be furnished to be used by the operators
_____ YES _____ NO

X8.24.3 Will you furnish all training aids; i.e. videos, projectors, etc. required in conducting the training
_____ YES _____ NO

X9.0 SPECIFICATIONS OF THE DUMP BODY

The bidder should complete the following schedule in order for the Division to compare the actual bid unit to the specifications. Should the bidder except a requirement, then such exception may be only on the basis that such feature is not offered by the manufacturer. The Division will have the sole discretion as to whether the bidder's substitution meets the requirements of the specifications.

Bidder: ACE TRUCK EQUIPMENT CO.

Address: 1130 NEWARK RD. ZANESVILLE, OHIO 43701

Telephone Number: 740-453-0551

Years company has been an authorized dealer for proposed unit: 14 years

Manufacturer, model, series, and date of manufacture of proposed Dump body:

HENDERSON MKE-WV2011

Is descriptive literature full describing proposed dump body attached to your bid proposal? X YES _____ NO

If NO, refer to specification statement Section 6.6

When will required number of operating manuals, service manuals, and complete parts list be delivered to the Equipment Division at Buckhannon? _____ prior to deliver of unit or WITH EQUIPMENT

Dump body warranty: SEE ATTACHED

X9.0.1 Water Level of dump body: 13 cu yd

X9.0.2 Will side board pockets and tailgate height provide additional capacities of 2-5 cu. yd.
X YES _____ NO

- X9.0.3 Front body bulkhead: _____ inch AR400 steel _____ PSI yield strength
*SEE ADDENDUM #6
- X9.0.4 Are rear corner posts full depth one-piece construction from the top of tailgate to bottom of rear bolster YES NO
- X9.0.5 Is rear bolster one piece full depth and full width YES NO
- X9.0.6 Are four (4) spreader strap retainers adequately welded on both sides of body inside YES NO
- X9.0.7 Is cab shield full width of body and sufficient clearance to ensure shield won't hit exhaust when dumping on uneven terrain YES NO
- X9.0.8 Are there two (2) front frame mounted tow hooks or eyes _____ YES NO
*SEE ADDENDUM #3
- X9.1 Dimensions:
- X9.1.1 Inside length of body: 174 inches
- X9.1.2 Inside width: 86 inches
- X9.1.3 Outside width: 96 inches at rub rail
- X9.1.4 Basic side height: 42 inches (measure from floor to top rail)
- X9.1.5 Tailgate height: 54 inches (measure from floor to top of tailgate)
- X9.1.6 Body overhang: 18 inches (measure from center of hinge pin)
- X9.1.7 Cab protector: 24 inches with adequate clearance for cab mounted air horns
- X9.1.8 Is cab protector sloped rearward for drainage purposes YES NO
- X9.2 Construction of the dump bed sides, front, head, and tailgate constructed with a the following minimums YES NO
- X9.2.1 Floor: _____ inch AR400 _____ PSI yield strength with _____ degree knee brace welded to floor *SEE ADDENDUM #6
Is body crossmemberless type _____ YES NO
*SEE ADDENDUM #6
- X9.2.2 Sides: _____ Gauge AR400 _____ PSI yield strength steel thickness
- X9.2.3 Tailgate Plate: _____ inch AR400 _____ PSI yield strength steel
*SEE ADDENDUM #6
- X9.2.4 Top Rail: 3/16 inch thickness *SEE ADDENDUM #6
- X9.2.5 Bottom Rail: 3/16 inch thickness
- X9.2.6 Cab Protector: 10 Gauge

X9.2.7 Longitudinal: 8 inch/ 13 lb.ft. I beam

X9.3 Are all the weldings inside the dump body continuous YES NO

Are all rails and posts continuous welded and completely closed YES NO

X9.3.1 The corner posts are 7 gauge Grade 50, 4 3/4 inch x 12 inch full depth tied to 12 inch formed channel rear apron

Is this joint further reinforced with a 1/4 inch plate that helps prevent flexing and strengthens latch assembly YES NO

X9.3.2 Cab protector sides, formed with gussets extend forward 24 inches.

Clearance above highest point of cab 3 inches

X9.3.3 Is there one (1) horizontal side brace, weld on, dirt shedding sloped side brace connected to front and rear corner posts YES NO

X9.3.4 Are all seams welded solid except crossmembers YES NO

X9.4 Hydraulic hoist :

Telescopic hoist YES NO Internal dog house YES NO of 12 inches

X9.4.1 Trunnion mount to bottom of dump body, not top of doghouse YES NO

X9.4.2 NTEA rating: Class 90 double acting with 26 ton capacity YES NO

X9.4.2 Is the hoist of the cross head sleeve twin side lift arms and links design for stability
*SEE ADDENDUM #3 YES NO

X9.4.3 Is the single hoist cylinder trunnion mount YES NO

X9.4.4 Does the hoist cylinder have three (3) stages YES NO with
*SEE ADDENDUM #3
 inches of stroke with five (5) inch diameter stage at bottom
 YES NO

Manufacturer and part number: _____

X9.4.5 Does the cylinder have wear and corrosion resistant nitrided cylinder tubes YES NO

X9.4.6 Cylinder warranty 2 year

X9.4.7 Does a five (5) degree oscillating cylinder collar protect the cylinder against inside stress with replaceable greaseless composite bushings at collar pivots YES NO

- X9.4.8 Does the body have 6 inch x 8 inch x 1/2 inch formed angle rear hinge assembly installed in the truck chassis frame YES NO
- X9.4.9 Are there two (2) inch 303 stainless steel hinge pins connecting to 2 1/2 inch hinge blocks using replaceable greaseless composite bushings for a minimal pin-to-bushing clearance YES NO
- X9.5 Features shall be included:**
- X9.5.1 Warning light (bed raised) dash or console mounted YES NO
- X9.5.2 Hydraulic oil level reading YES NO
- X9.5.3 Safety decals as required YES NO
- X9.5.4 Mud guards permanently attached in front of rear wheels YES NO
10 Gauge x 24 inches x 30 inches
 Will you align exhaust stack for bed clearance YES NO
- X9.5.5 Shovel bracket (front of bed behind driver) YES NO
- X9.5.6 Are gussets for 4 inch x 6 inch lumber (rough) located at front and rear posts and mid-rail 42 inch x 6 inch (rough) oak sideboards supplied and bolted through gussets YES NO
- X9.5.7 Air operated tailgate latches are pancake type tailgate release valve YES NO
- Manufacturer and model: BUYERS P/N 3018130
- With spring-over-center latch and pivot points include stainless steel bushings to reduce seizing YES NO
- X9.5.8 Self cleaning safety platform non-skid material located on both sides of dump body, consisting of 1 1/2 inch Bustin hole grip strut installed at bottom of body sides
 *SEE ADDENDUM #3 YES NO
- X9.5.9 OSHA approved backup alarm, electronic ambient, adjusts to background noise, 112 dba shock mounted at rear YES NO
- X9.5.9.1 OSHA approved body support, both sides YES NO
- X9.5.10 Slope outside of bottom red rail YES NO

X9.5.11 Is unit equipped with 49,000 lb. capacity pintle hook centered between rear frame rails
 YES NO

Manufacturer: WALLACE Part No.: B30

Is height from ground level to center line of pintle "eye" 32 inches
 YES NO

X9.5.12 Is air deflector hood mounted, blue or smoke YES NO

*SEE ADDENDUM #3

Is deflector manufacturers standard width for truck made YES NO

*SEE ADDENDUM #3

Is access to front end hood tilt handle avoided YES NO

*SEE ADDENDUM #3

X9.6 Lighting: Weather/shock resistant marker lights, LED type with average amp draw between .045-.72
 YES NO Manufacturer: TRUCK LITE

Do all connections have sure snap plug assemblies and epoxy sealed electronics to protect against shock and vibration
 YES NO

X9.6.1 Are marker lights 2 1/2 inch diameter flush mounted sealed beam lights with integral reflector mounted in rubber base
 YES NO

X9.6.2 Are all lights connected to chassis through a waterproof junction box located at rear of truck
 YES NO

X9.6.3 Are rear lights shock mounted, recessed oval stop, tail, turn, and recessed oval backup lights mounted in back post
 YES NO

Are strobe lights marked and switched from dash board location YES NO

X9.6.4 Are center rear I.D. Lights three (3) located in truck chassis YES NO

X9.6.5 Are there two (2) amber oval L.E.D. strobe lights mounted at front corners of the cab protector
 YES NO

Are there two (2) amber oval L.E.D. strobe lights mounted at each outside corner of the cab protector
 YES NO

Are strobe lights marked and switched at dash board location YES NO

Manufacturer: TRUCK LITE Part No. 60122Y

Are oval cutouts precut by dump body manufacturer YES NO

X9.6.6 Auxiliary headlights for snow plowing application shock mounted on fender of unit
 YES NO

Manufacturer: TRUCK LITE Part No. 80800

- X9.6.7 Are there two (2) oval amber L.E.D. strobe lights mounted at top of rear corner posts right and left sides YES NO
- Are they switched in combination with cab protector strobe YES NO
- Manufacturer: TRUCK LITE Model: 60122Y
- Are oval cutouts precut by dump body manufacturer YES NO
- X9.6.8 Angled hydraulic fittings are mounted above the lights, and the vertical apron is cut out above the frame to facilitate their placement YES NO
- X9.6.9 Two (2) front frame mounted tow hooks YES NO
- X9.6.10 Lighted license plate bracket YES NO
- X9.7 Does a full length dirt shedding rub rail extend along each side of the body, sufficient to cover the rear wheels YES NO
- X9.8 The following should be at the front of both sides of the body on posts:
- X9.8.2 Is full height fold down style ladder with 1 1/2 inch Bustin style 16" rungs installed front of body, both YES NO
*SEE ADDENDUM #3
- X9.9 Tailgate:
- X9.9.1 Tailgate hinged at top with flush mount, 1/2 inch flame cut pivots, one (1) inch pork chop type off-set hardware to achieve maximum opening of tailgate, but have provisions for pivoting at bottom YES NO
*SEE ADDENDUM #1 and #3
- X9.9.2 Top hinge channel with removable, chain tethered keeper pins YES NO
- X9.9.3 Latching action at bottom of gate is 3/4 inch latch hooks with 3/8 inch latch plates operable by the truck driver without leaving the truck cab YES NO
- X9.9.4 Gate self-aligning YES NO
- X9.9.5 Tailgate upper and lower latch pins 1 1/4 inch diameter hot rolled YES NO
*SEE ADDENDUM #1 FOR ADD OF SPEC X9.9.6 AND X9.9.7
- X9.10 The design and strength characteristics of the entire dump such that the unit structural members and the hoisting system suffers no deformation, damage, or structural failure resulting from raising a distributed full payload YES NO
- X9.11 The location of the dump box pivot point in relation to the rear end of the truck frame and in relation to the rear lip of the box floor such that the horizontal distance from floor lip to the rear end of the frame is 18 inches YES NO

X9.12 Bumper

- X9.12.1 The bumper is formed out of 1/4 inch roll steel YES NO
 Weight: 10.20 lbs. per square foot
- X9.12.2 Bumper face to cover all of truck frame (12* inches) with two (2) flanges
2.25* inches top and bottom YES NO
 *APPROXIMATELY
- X9.12.3 Bumper overall width: 94* inches *APPROXIMATELY
- X9.12.4 Bumper is straight across front from centerline of truck chassis 21* inches each side of centerline,
 making bumper straight 42* inches long in center with ends swept back 30* degrees and 27*
 inches each side YES NO *APPROXIMATELY
- X9.12.5 Upper and lower flanges cut and welded solid at point where bumper is bent and ground off smooth
 YES NO
- X9.12.6 Bumper mounted by two (2) mounting angles bolted to front of truck frame with two (2) 5/8 inch
 bolts each side YES NO
- X9.12.7 Mount angle 1/4* inches x 3* inches x 8* inches long with four (4) 5/8 inch holes
 *APPROXIMATELY
- X9.12.8 Front bumper paint: BLUE
- X9.13 Under Body Tool Box:
- X9.13.1 One (1) tool box mounted under body on right side frame rail YES NO
- X9.13.2 Tool box 18 inches high 24 inches wide 18 inches deep cradles by a heavy steel angle
 frame attached to the truck frame YES NO
- X9.13.3 Construction of 14 gauge A-60 galvaneal steel with all seems welded
 YES NO
- X9.13.4 Tool box has a horizontal hinged fold down door YES NO
- X9.13.5 Tool box door has cable or chain to hold the door in a horizontal position
 YES NO
- X9.13.6 Tool box has keyed latch of corrosion resistant hardware, automotive style weather stripping, and a
 drip rail over the door opening YES NO
- X9.14 Load covering system electrically controlled: YES NO
- X9.14.1 Does electric motor assembly include 12 volt direct drive motor with forward and reverse action, cab
 mounted control switch, resettable circuit breaker
 YES NO
- X9.14.2 Pivot arm assembly constructed in a two (2) piece bent arm configuration of 1.25*inch 14*
 gauge steel tubing *APPROXIMATELY

X9.14.3 Bent arm extensions constructed of 1 inch 14 gauge steel tubing

X9.14.4 Rear cross constructed of 1.25inch 14 gauge steel tubing

X9.14.5 Pivot arm rests included X YES NO

X9.14.6 Underbody spring extension spring 12 inches in length attached to base of pivot arm and of body with articulating spring mounting bracket X YES NO

X9.14.7 All steel components finished with manufacturer's recommended rust preventative system to include a minimum of adequate primer and paint X YES NO

X9.14.8 Load covering system provided with 18 oz black vinyl tarp to fit dump body X YES NO

X9.14.9 Load covering system supplied with all necessary hardware and delivered to the WVDOH as a complete and operational unit X YES NO

X9.15 Paint:

X9.15.1 - 9.15.2.1 Describe proposed method of painting: DUMP BODY TO BE SHOT BLASTED,

DEGREASED, AND CLEANED BEFORE PRIMING. DUMP BODY TO BE PRIMED AND TOP

COATED WITH TWO (2) COATS OF BLUE FINISH PAINT. FRONT BUMPER TO BE CLEANED,
PRIMED, AND PAINTED BLUE.

X9.16 Detail/Decorative Stripes with Logo.

Will striping and detailing you provide comply with requirements of Section 9.16.1 through 9.16.7

X YES NO

X9.17 Other standard features:

List other standard features offered and not addressed above:

X9.18 Does the proposed unit meet or exceed the "OSHA OF 1970" and/or subsequent changes

X YES NO

HENDERSON PRODUCTS INC
COMPLETE WARRANTY PROVISIONS

APPLIES TO ___West Virginia Bid #7011EC10 Dump Body

Authorized by: Janet Tobin ~ Contract Administration Manager Dated: Feb 7, 2011

A. PARTS REPLACEMENT AND REPAIR:

Henderson Products Inc warrants its manufactured products to be free from defects in material or workmanship for a period of 2 years, after delivery to the original user. This warranty of our products under normal use and service is limited to replacement and repair, at the company's factory, of any parts which are returned to the factory freight prepaid, and after our examination were found to be defective.

B. EXCLUSIONS:

1. This warranty is expressly limited to parts replacement and repair, and is not transferable. Any expressed warranty not herein provided, and any remedy for breach of contract is excluded and disclaimed. The implied warranties of merchantability and of fitness for any particular purpose are limited to 2 years from delivery to the original user.
2. Any component or part manufactured by others will carry that manufacturers' warranty, and in no case will Henderson Products Inc be liable, either expressed or implied, for warranties in excess of those made by the original manufacturer.
3. Under no circumstances will Henderson Products Inc be liable to the purchaser, or any other person, for any incidental or consequential damages. The user assumes liability for all personal injury or property damage resulting from the handling, possession, or use of the product.
4. Repairs or modifications done by others, or parts from other sources outside the company's factory are not covered by this warranty.

WARRANTY PROCEDURE

1. Prior authorization by Henderson Products Inc must be obtained for all warranty work
2. Contact our distributor or Henderson Product Inc giving complete details of your request, the unit involved, including serial number, date purchased, who purchased from, and the nature of or reason for the claim.
3. A Warranty Request Number will be assigned, and is required, whenever any warranty is to be paid either in the form of cash, credit, replacement of parts, or service work.
4. The assignment of a Warranty Request Number does not guarantee warranty will be allowed. The number is to identify the request and part to be returned.
5. When parts are shipped on a Warranty Request, you may be required to return defective part(s) for inspection by Henderson Products Inc or the original manufacturer. In this case, you will be invoiced for shipment of new components until the old unit is returned.

X10.0 SECTION THREE - CENTRAL HYDRAULIC SYSTEM

Reference Requisition No. on request for proposal:

7011EC10

Bidder's Name: ACE TRUCK EQUIPMENT CO.

Address: 1130 NEWARK RD. ZANESVILLE, OH 43701

Telephone Number: 740-453-0551

Years Company has been an authorized dealer for proposed unit:

14 YRS

Manufacturer, model, series, and date of manufacture of proposed Hydraulic System:

CERTIFIED POWER SG03080009 WEST VIRGINIA SYSTEM MANUFACTURED AS

REQUIRED FOR CONTRACT.

Is descriptive literature, fully describing proposed system attached to your bid proposal?

X YES NO

If NO, refer to specification statement Section 7.5

When will required number of operating manuals, service manuals, and complete parts list be delivered to the Equipment Division at Buckhannon? X prior to delivery of unit

or _____ (MANUALS ARE ALSO AVAILABLE ONLINE)

Will hydraulic system be designed to operate a front mounted telescopic dump body hoist cylinder, a hydraulically driven integrated salt and abrasive spreader requiring the simultaneous operation of 2 hydraulic motors in 2 different modes with conveyor reverse, a double acting snowplow lifting cylinder, a snowplow power angle system, plow balance system, and an auxiliary equipment drive circuit

 X YES NO

Are provisions made for future add-on hydraulic driven pre-wet system

 X YES NO

Pre-wet system:

Will supplied spreader control contain the ability to control a closed loop pre-wet system.

 X YES NO

Will system operate using a flow meter feedback circuit X YES NO

Will controller software allow for adjustability of pre-wet output by the operator, represented in gallons per ton X YES NO

Will information related to pre-wet application rate and total flow in gallons be displayed on the screen while the pre-wet system is active. X YES NO

Central hydraulic system warranty: TWO (2) YEAR WARRANTY BUMPER TO BUMPER
PARTS AND LABOR

X10.1 Pump System:

X10.1.1 Is pump variable volume pressure compensated load sensing axial piston type
 YES NO

X10.1.2 Are the front mounting flange and main housing/case of cast iron construction
 YES NO

Are the inlet and outlet port section of high strength ductile iron with SAE split flange or orb type porting
 YES NO

X10.1.3 Is suction port and associated plumbing sized to allow for minimum inlet restriction between the pump and the suction port on the reservoir
 YES NO

Does installation comply with pump manufacturers allowable inlet condition specifications
 YES NO

Is suction plumbing equal to or greater than pump inlet or suction size
 YES NO

X10.1.4 Is pressure port of the SAE split flange or ORB type side mounted for direct bolt mounting of solenoid shut down valve assembly
 YES NO

X10.1.5 Are case drain and load sense signal ports of the SAE o-ring type
 YES NO

Is case drain line taken directly to tank without passing through the return line filter
 YES NO

X10.1.6 Does the input shaft have a minimum continuous torque rating equal to 200% of the imposed load when pump is operated at maximum engine rpm, maximum displacement and system pressure
 YES NO

Is it minimum SAE "C" keyed
 YES NO

X10.1.7 Is front shaft bearing of the heavy duty ball or roller type designed for high axial and radial loading
 YES NO

Is rear shaft bearing of high speed and load sleeve type design YES NO

Are bearings fully lubricated by flooded case oil
 YES NO

- X10.1.8 Is ramp/swashplate supported by pressure lubricated bearings of rocker cam ___ or Saddle type for high piston load support YES ___ NO
- Is ramp angle positioning by means of dual servo control cylinders for rapid pump response and precise pump output control YES ___ NO
- X10.1.9 Is adjustable load sense and high pressure compensator control valve assembly of the full cartridge ___ or of bolt-on housing design for ease of replacement and repair YES ___ NO
- X10.1.9.1 System is designed and components to provide flow, pressure, and performance requirements as stated with operating load sense differential pressure of 300 PSI and a maximum standby pressure of 350 PSI for maximum efficiency YES ___ NO
- Is pilot control shifted valving utilized in the system ___ YES NO
Are they designed to be fully functional within this pressure Range YES ___ NO
- X10.1.9.2 Is high pressure compensator valve preset to limit the maximum pump output pressure to the maximum required operating pressure plus sense differential and margin pressure prevent premature de-stroking of ramp resulting in reduced or insufficient pump output YES ___ NO
- X10.1.10 Pump Output: 75 cc/Revolution
Is it capable of providing hoist cylinder extension required YES ___ NO
- Manufacturer and part number: CS 130-5.5-3
- 9.9 gallons to fully extend
- | | |
|------------------|-----------------------------|
| 5 GPM flow rate | <u>120</u> seconds to raise |
| 10 GPM flow rate | <u>60</u> seconds to raise |
| 15 GPM flow rate | <u>40</u> seconds to raise |
| 20 GPM flow rate | <u>30</u> seconds to raise |
| 25 GPM flow rate | <u>24</u> seconds to raise |
| 30 GPM flow rate | <u>20</u> seconds to raise |
| 40 GPM flow rate | <u>15</u> seconds to raise |
- X10.1.11 Is the pump you are supplying of overall quality of construction, design, and Performance YES ___ NO
- X10.1.12 Pump Manufacturer and model: SAUER DANFOSS SERIES 45 J FRAME 75CC
- X10.1.13 Is pump of a manufacturer's standard product release and design YES ___ NO
- X10.1.14 Is pump driveline assembly of the keyed shaft design utilizing a 4 bolt driveshaft flange and matching drive yoke on the pump YES ___ NO

X10.1.14.1 Does driveline have a minimum continuous torque rating equal to 200% of the imposed load when pump is operating at maximum system requirements
 YES NO

Manufacturer and model: SPICER 1310 SERIES

X10.1.14.2 Are dual journals and yokes incorporated to connect the pump shaft and engine drive flange with an angular misalignment no greater than six (6) degrees and not less than two (2) degrees
 YES NO

X10.2 Pump Shutdown System:

X10.2.1 Is the normally closed, energized to open, solenoid operated control valve of the cartridge and manifold design to be directly bolted to pump pressure port
 YES NO
 Is solenoid electrical connection of the Packard "Weatherpack" type with "SO" cable Wiring
 YES NO

X10.2.2 Is it valve controlled by a console mounted "Master On" switch with pilot lamp for normal system operation and by a float switch located in hydraulic reservoir to automatically shut off pump pressure port flow to all down stream functions in the event of low hydraulic oil level
 YES NO

X10.2.3 Pressure drop across valve 40 PSI at 40 GPM flow when in the switched open position
 Nominal valve rating of 50 GPM @ 3500 PSI

X10.2.4 Is SAE #6 gauge port equipped with Parker Hannifin Model PD361 diagnostic coupling nipple and protective cap provided for pump output pressure testing to be installed in valve manifold and within an easily accessible mounting position
 YES NO

X10.2.5 Is valve designed to protect the pump for damage when system is shut down at high pressure and flow operation
 YES NO

X10.2.6 Valve Manufacturer and model: CERTIFIED POWER HF010809

X10.2.7 Is central control console mounted audio alarm and warning lamp indicating pump pressure/flow shutdown provided
 YES NO

X10.2.8 Is warning lamp a press-to-test and incorporate a switching system into the automatic shutdown assembly to simulate low oil level, shut off pump output flow and test float switch wiring and connections
 YES NO

X10.2.9 Is a console mounted electrical override function switch provided to allow momentary operation of hydraulic functions in emergency situations
 YES NO

X10.3 Directional Control Valve Assembly:

X10.3.1 Is valve stacked section type and of closed center circuit design

 YES NO

X10.3.2 Is each work section pressure and flow compensated with fully integrated load sense network

 YES NO

Is flow output relative to spool travel with preset maximum flow rate obtained at maximum spool stroke to provide feathering control of operated function

 YES NO

X10.3.3 Are dump body, snowplow lift and snowplow power angle sections of the manual cable shift type

 YES NOIs auxiliary circuit section of the electric solenoid shift type YES NO

Are both ends of each section valve spool sealed with weather resistant caps or cable entry bonnets

 YES NO

X10.3.4 Is valve assembly flow capacity rating and pressure drop characteristics sufficient to provide for the required pump output and circuit flow rates at the specified maximum load sense differential pressure settings

 YES NO

X10.3.5 Are all valve ports of the SAE o-ring seal type and of sufficient size to handle required section flow rates at stated load sense differential pressure

 YES NO

X10.3.6 Is system pre-compensated requiring a priority section installed to allow plow to raise in a system over demand situation

 YES NO

(OR)

Is system post compensated, not requiring priority section

 YES NO

X10.3.7 Is a main pressure inlet relief valve provided to reduce system pressure shock loads

 YES NO

Is it preset at pressure so as not to interfere with pump pressure compensator and to prevent premature relief opening at system high demand operation

 YES NO

X10.3.8 Is pilot pressure reducing valve required for solenoid section control

 YES NO

Is it designed to meet operating requirements as set forth in Section 10.1.9.1

 YES NO

Is pilot supply and tank venting internal within the valve assembly sections

 YES NO

- X10.3.9 Is load sense network high pressure relief provided and preset to limit system maximum operating pressure YES NO
- Will set point provide proper pressure margin to pump pressure compensator and high pressure relief valve as to prevent premature loss of required flow rates and pressure capability YES NO
- X10.3.10 Is SAE #6 gauge port equipped with Parker Hannifin PD361 diagnostic coupling nipple with protective cap for load sense testing installed in an easily accessible location YES NO
- X10.3.11 Is dump body control section 4-way three position spring centered cylinder spool for operation of a double acting hoist cylinder YES NO
- X10.3.11.1 Is full flow workport relief valve installed in power up port YES NO
- Will set point prevent operating pressure from exceeding hoist cylinder normal operating pressure rating YES NO
- X10.3.11.2 Is full flow workport relief valve installed in the power down port, set at 500 PSI to prevent full system pressure on down stroke YES NO
- X10.3.12 Is snowplow lift control section 4-way three position spring centered cylinder spool for operation of a double acting lift cylinder YES NO
- X10.3.12.1 Is an adjustable flow control installed to limit downward speed of snowplow YES NO
- Is flow limiting control system preset for proper plow lift speed supplied to reduce over demand operation and to increase system efficiency YES NO
- X10.3.13 Is snowplow power angle control section 4-way three (3) position spring centered motor spool for operation of worm gear driven type reversing system YES NO
- X10.3.13.1 Is flow limiting control system preset for proper plow reversing speed supplied to reduce over demand operation and to increase system efficiency YES NO
- X10.3.14 Plow Balance Valve:
- X10.3.14.1 Is hydraulic system supplied with a plow balance valve YES NO
- X10.3.14.2 Is valve designed to offset a specific (adjustable) plow weight when activated YES NO

X10.3.14.3 Does plow balance system alter the operation of any other hydraulic function or have an adverse effect on the performance of other hydraulically operated equipment including:

Wing Plow	_____	YES	<u>X</u>	NO
Body Hoist	_____	YES	<u>X</u>	NO
Plow Hoist or Angle	_____	YES	<u>X</u>	NO
Spreader functions	_____	YES	<u>X</u>	NO

Will all normal operations of the plow lift/lower functions be maintained without additional tasks

X YES _____ NO

X10.3.14.4 Is plow lift immediate to guarantee safe operation of vehicle

X YES _____ NO

X10.3.14.5 Are solenoid valve coils used
Do they have manual override capabilities if needed for continued use when coils fail

X YES _____ NO
X YES _____ NO

X10.3.14.6 Does manifold valve include a pressure test point for use when checking balance pressures

X YES _____ NO

X10.3.14.7 Is pressure test point capable of tapping into system at pressures of 5000 PSI

X YES _____ NO

X10.3.15 Is auxiliary equipment drive circuit control section 3-way three position spring centered solenoid operated motor spool

X YES _____ NO

Is this circuit separate and distinct from spreader control system X YES _____ NO

X10.3.15.1 Is flow limiting control system preset to provide a maximum of 22 GPM at a system load pressure of 2200 PSI

X YES _____ NO

Is pump capable of supplying this flow rate with engine speed of 1400 RPM

X YES _____ NO

X10.3.15.2 Is an inline mounted control valve supplied for this operation in place of directional control valve section

_____ YES X NO

Is it supplied _____ YES X NO

Are proper interconnections and venting of load sense network system Provided NOT APPLICABLE _____ YES _____ NO

X10.3.15.3 Is pressure line 3/4" SAE100R2 hose and manifold mounted at rear of chassis and equipped with Parker Hannifin SH6-62 quick disconnect coupler and protective metal plug

X YES _____ NO

Is mating nipple SH6-63 with protective cap supplied X YES _____ NO

X10.3.15.4 Directional and auxiliary circuit valves Manufacturer and model:

SAUER DANFOSS PVG32

X10.3.16 Is directional control valve assembly located in a combination tank/valve enclosure assembly to protect the hydraulic tank/valve from elements*SEE ADDENDUM #3 YES NO

Reservoir (tank): _____ gallon capacity *SEE ADDENDUM #3

X10.3.17 Pre-Wet Circuit:**X10.3.17.1 Is a separate circuit provided to control an add-on pre-wet system** YES NO**X10.3.17.2 Is a hydraulic valve of the section type _____ or of the cartridge style**
Contained in a manifold**X10.3.17.3 Is a manifold type valve supplied** YES NOIs it attached to the main valve assembly YES NO**X10.3.17.4 Is all wiring to the pre-wet hydraulic circuit provided as part of the system** YES NO**X10.3.17.5 Is wiring to the control console related to the rest of the pre-wet system provided as part of the pre-wet package at the time of pre-wet system installation** YES NO**X10.4 Spreader Control Valve Assembly:****X10.4.1 Are spinner and conveyor solenoid flow controls of the PWM proportional solenoid type and equipped with manual overrides** YES NO

Are overrides manually adjustable over operating flow range in the event of electrical system failure

 YES NO**X10.4.2 Are flow control circuits pressure compensated and provide a spinner and pre-wet flow rate of 0-7 GPM and a conveyor flow rate of 0-15 GPM** YES NOPressure relief valve system limit circuits to 2200 PSI**X10.4.3 Are load sense circuits connected to directional control valve network for proper pump control** YES NO

Does design prevent improper high pressure load sense signal and pressure line loading when spreader valve is not in use and when spreader quick disconnects are uncoupled

 YES NO

- X10.4.4 Is PWM solenoid control supplied by microprocessor spreader control system
 YES NO
- Are solenoids capable of 100% PWM signal without failure YES NO
- X10.4.5 Is solenoid operated directional control valve and in-cab mounted electrical switch to operate spreader conveyor reverse required for front or rear material discharge selection provided
 YES NO
- X10.4.6 Are electrical switching and indicator light for spreader clogged indication provided
 YES NO
- X10.4.7 Proposed valve Manufacturer and model: SAUER DANFOSS PVG32 MANIFOLD
- X10.5 Spreader Control System:
- X10.5.1 Is dual flow, ground speed oriented spreader control system of the closed loop microprocessor based type with nonvolatile control memory YES NO
- X10.5.2 Is programming automatic calibration and flexibility YES NO
- X10.5.3 Is system capable of operation in ground speed oriented closed loop conveyor feed back, open loop, manual set, blast and unload modes YES NO
- X10.5.4 Is automatic switchover with display indication from closed loop to open loop operation in the event of loss of feed rate sensor signal provided YES NO
- X10.5.5 Are control console digital readouts capable of displaying actual application rate, vehicle ground speed, distance of spread route driven and total quantity of material spread
 YES NO
- X10.5.6 Are programming and output cable connection for material and trip information printer and program uploading provided
 YES NO
- X10.5.7 Is control unit capable of accumulating such display information up to 999,999 miles and 999,999 tons of discharged material
 YES NO
- X10.5.8 Is console programming capable of selection, calibration and display of four (4) separate spread materials with independent application rates of each material capable of being set to fixed rates or to rate increments of a preset maximum application rate
 YES NO
- X10.5.9 Is a variable digital access code lockout for application rate selection and for system operating parameters provided
 YES NO
- X10.5.10 Are backlighted switches and LCD screen utilized for on-board programming and for display readout and application rate selection YES NO

X10.5.11 Is material spread width selectable by no less than a ten (10) position switch with minimum and maximum spinner speed totally programmable through entire flow range. YES NO

Is spinner speed capable of linking to ground speed for on-off control YES NO

X10.5.12 Does display enunciate error message and sound audio alarm when microprocessor system detects any loss of control or accuracy YES NO

X10.5.13 Will system be fully functional at time of delivery YES NO

X10.5.14 Will truck speed sensor be compatible with type of speedometer drive system supplied on chassis YES NO

X10.5.15 Will a built-in ground speed simulator be provided either internal to the control or located in the control console YES NO

X10.5.16 Will all components required for proper installation and operation of control system onto truck and spreader units be supplied YES NO

X10.5.17 Control System Manufacturer and model: CERTIFIED POWER SG51 W/GL400

X10.6 Central Control Console:

X10.6.1 Mounted between seats within easy access of driver YES NO

X10.6.1.1 Warning light (bed raised) control console mounted YES NO

X10.6.2 Is all wiring, valve control cables, and electrical harness entry into cab and console sealed with grommets YES NO

X10.6.3 Are remote control valve levers console mounted YES NO

Are all levers clearly marked as to their function and operation YES NO

X10.6.3.1 Are remote control levers to operate push-pull type cables with .250" diameter stainless steel rod ends YES NO

X10.6.3.2 Is inner cable member 18-8 stainless steel armor wrapped construction with a low resistance nylon liner and polyethylene covered tempered steel wire conduit YES NO

X10.6.3.3 Is cable to valve connection of the weather resistant bonneted type YES NO

- X10.6.3.4** Is the hoist control lever OSHA 1926.601(b)(11) compliant YES NO
- X10.6.4** Is central control console or dash mounted rocker switches with indicator lamps provided for strobe lights, spreader light, and plow lights isolated from all hydraulic system control circuits YES NO
- X10.6.4.1** Are all interconnections and cables installed and ready for operation YES NO
- X10.6.4.2** Is hydraulic system automatic shutdown system and control switching relay Controlled YES NO
- X10.6.4.3** Are relay(s) mounted within the cab YES NO
- X10.6.4.4** Is an access plate to internal wiring provided YES NO
- X10.7** Hydraulic Reservoir and Valve Enclosure Assembly:
- X10.7.1** Is tank/valve enclosure flex mounted to the chassis frame rail YES NO
- X10.7.2** Tank construction: 7 GAUGE 304 STAINLESS STEEL
- X10.7.3** Is tank equipped with a combination oil level sight glass and thermometer YES NO
- X10.7.4** Is tank equipped with a ten (10) micron filler/breather cap with removable five hundred (500) micron strainer YES NO
- X10.7.5** Is an internal steel baffle provided within tank YES NO SEE ADDENDUM #3
- X10.7.6** Size of stenciling on tank "Hydraulic Oil": 1.5 inches high
- X10.7.7** Is tank level switch connection "SO" type wiring and mounted within the tank/valve enclosure to protect it from elements YES NO
- X10.7.8** Pump supply suction port inch NPT and system return port inch NPT
SEE ADDENDUM #3
- X10.8** Filtration:
- X10.8.1** Is filtration manufacturers standard to adequately protect the hydraulic system from Damage YES NO
- X10.8.2** Is return line filter isolated from reservoir by a full flow non-restrictive type quarter turn brass ball valve if filter is not installed in reservoir YES NO NOT APPLICABLE
- X10.8.3** Is each filter equipped with a differential pressure switch to indicate filter clogged condition by means of a console mounted indicator lamp YES NO

- X10.8.4 Is one (1) extra replacement filter for each assembly provided for each truck
 YES NO
- X10.8.5 Are filter assemblies positioned as close to reservoir as possible and in an easily accessible service location
 YES NO
- X10.9 Hoses and Fittings:
- X10.9.1 Is each hose assembly, except for suction hose, fitted with JIC swivel connectors on ends where connection to system component is made YES NO
- X10.9.2 Do all pressure line hoses meet or exceed SAE Specification 100R2 and equal to Gates high pressure hose, type C2AT for sizes up to and including 1" ID
 YES NO
- X10.9.3 Is suction hose 2" nominal ID SAE Specification 100R4, braided fiber, spiral wire reinforced, rubber covered hose with replaceable bolt-on type fittings
 YES NO
- X10.9.4 Are all hydraulic hoses fully cleaned on interior, installed and ready for operation
 YES NO
- X10.9.5 Are grommets used when routing hoses through steel bracketing or frame members
 YES NO
- X10.9.6 Are Snap-Tite quick disconnects (manifold mounted) supplied for the spinner 1/2 inch pressure and return lines
 YES NO SEE ADDENDUM #3
- X10.9.7 Are all fittings and connectors steel type designed for high pressure hydraulic system
 YES NO
- X10.9.8 Were pipe thread ported components and connectors used only when the specific component is not available with SAE or JIC Porting YES NO
- X10.9.9 Were all pipe thread connectors coated with liquid teflon pipe sealer before assembly?
 YES NO
- X10.9.10 Are the hoses run to the front of truck chassis for snowplow functions manifold mounted behind the front bumper with sufficient access for pump assembly service and snowplow hitch installation
 YES NO
- X10.9.11 Are lines equipped with complete 1/2" VH" series Snap-Tite quick disconnects, metal caps and plugs
 YES NO
- X10.10 Other Standard Features: _____
-

X10.11 Initial servicing and pretesting:

X10.11.1 Initial fill of reservoir with high grade 32AW hydraulic fluid 40 gallon level marked on sight glass YES NO

X10.11.2 Start up and initial run of hydraulic system, checking for leaks, excess heat, system efficiency YES NO

Will you replace any defective component YES NO

You will be responsible for any defects discovered at the time of installation of spreader and plow YES NO

X10.12 Are hydraulic lines located within 10" of exhaust system metal lines YES NO

X10.12 If successful vendor, will you provide WVDOH with complete list of all filters for normal maintenance? YES NO

X10.13 Have you included with your bid detailed component specifications, product literature, system component layout drawing with bill of materials and full functional hydraulic system schematics in accordance with JIC and ANSI-Y32 YES NO

X10.14 If you are the successful vendor, will you provide WVDOH with complete list of all filters required for normal maintenance on unit YES NO

X10.15 Describe your training sessions that will be provided with each order at an Equipment Division facility:

THREE (3) ONE (1) DAY TRAINING SESSIONS PER PURCHASE ORDER.

**ADDENDUM #1
OPEN END CONTRACT 70-11-EC10**

64,000 GVW CAB AND CHASSIS, DUMP BODY, AND HYDRAULIC SYSTEM

CHANGES TO BIDDER'S EVALUATION:

NO CHANGE REQUIRED:

X9.9 TAILGATE: SLOPED ASPHALT STYLE

FROM:

X9.9.1 Tailgate hinged at top with flush mount, ½ inch flame cut pivots, one (1) inch pork chop type off-set hardware to achieve maximum opening of tailgate, but have provisions for pivoting at bottom YES NO

TO:

X9.9.1 Does body have sloped rear corner posts with a tapered bottom angle to give adequate clearance when dumping into an asphalt paver or chip machine? X YES NO

Clearance from bottom corner of rear corner post to ground when body is at 50 degree dump angle: 32 Inches ASSUMING 42" FRAME HEIGHT

FROM:

X9.9.2 Top hinge channel with removable, chain tethered keeper pins YES NO

TO:

X9.9.2 Is tailgate hinged at top with flush mount, ½ inch flame cut tailgate pivots, one (1) inch pork chop type off-set hardware to achieve maximum opening of tailgate YES NO

*SEE ADDENDUM #3

Are there provisions for pivoting at bottom YES NO

*SEE ADDENDUM #3

ADD:

X9.9.6 Is the design and strength characteristics of entire dump unit such that the unit structural members and the hoisting system will not suffer any deformation, damage, or structural failure resulting from raising a distributed full payload X YES NO

ADD:

X9.9.7 Is the location of the dump box pivot point in relation to the rear end of the truck frame and in relation to the rear lip of the box floor such that the horizontal distance from floor lip to the rear end of frame 16 inches. X YES NO

NO CHANGE REQUIRED:

X9.4.4 Does the hoist cylinder have three (3) stages YES NO with

130 inches of stroke with five (5) inch diameter stage at bottom

YES NO

Manufacturer and part number: MAILHOT CS130-5.5-3DA

FROM:

X9.5.8 Self cleaning safety platform non-skid material located on both sides of dump body, consisting of 1 ½ inch Bustin hole grip strut installed at bottom of body sides Y N

TO:

X9.5.8 Self cleaning safety platform non-skid material located on both sides of dump body, consisting of 1 ½ inch grip strut installed at bottom of body sides

YES NO

FROM:

X9.5.12 Is air deflector hood mounted, blue or smoke Y N

Is deflector manufacturers standard width for truck made Y N

Is access to front end hood tilt handle avoided Y N

TO:

X9.5.12 Is air deflector hood mounted, blue or smoke YES NO

Is deflector manufacturers standard width for truck model

YES NO

Deflector size: 46* inches *APPROXIMATE DEPENDING ON CHASSIS SELECTED AND HOOD CONFIGURATION.

Is access to front end hood tilt handle avoided YES NO

FROM:

X9.8.2 Is full height fold down style ladder with 1 ½ inch Bustin style 16" rungs installed front of body, both Y N

TO:

X9.8.1 Is full height fold down style ladder on one (1) side with 1 ½ inch grip strut style 16" rungs installed front of body X YES NO

FROM:

SEE ADDENDUM #1

X9.9.2 Tailgate hinged at top with flush mount, ½ inch flame cut pivots, one (1) inch porke chop type off-set hardware to achieve maximum opening of tailgate, **but have provisions for pivoting at bottom** Y N

TO:

X9.9.2 Tailgate hinged at top with flush mount, ½ inch flame cut pivots, one (1) inch pork chop type off-set hardware to achieve maximum opening of tailgate X YES NO

DELETE:

SEE ADDENDUM #1 – REMOVED WHEN 9.9.2 WAS REWRITTEN

Top hinge channel with removable, chain tethered keeper pins Y N

NO CHANGE REQUIRED OTHER THAN A MANDATORY NOW

X10.2.1 Is the normally closed, energized to open, solenoid operated control valve of the cartridge and manifold design to be directly bolted to pump pressure port

 X YES NO

Is solenoid electrical connection of the Packard "Weatherpack" type with "SO" cable wiring X YES NO

FROM:

X10.3.16 Is directional control valve assembly located in a combination tank/valve enclosure assembly to protect the hydraulic tank/valve from elements **_Y_N**
Reservoir (tank): gallon capacity

TO:

X10.3.16 Is directional control valve assembly located in a combination tank/valve stainless enclosure assembly to protect the hydraulic tank/valve from elements
 X **YES** **NO**

Reservoir (tank): 40 gallon capacity

FROM:

X10.7.5 Is an internal steel baffle provided within tank **_Y_N**

TO:

X10.7.5 Is an internal stainless steel baffle provided within tank **X** **YES** **NO**

FROM:

X10.7.8 Pump supply suction port **inch NPT and system return port** **inch NPT**

TO:

X10.7.8 Reservoir supply suction port 2 **inch NPT and system return port** 1.25 **inch NPT**

FROM:

X10.9.6 Are Snap-Tite quick disconnects (manifold mounted) supplied for the spinner ½ inch pressure and return lines **_Y_N**

TO:

X10.9.6 Are Snap-Tite quick disconnects (manifold mounted) supplied for the spinner ½ inch pressure and return lines **X** **YES** **NO**

VH Series or equal Auger/Conveyor

 X **YES** **NO**

ADDENDUM #6
70-11-EC10

OPEN END CONTRACT

64,000 GVW CAB AND CHASSIS, DUMP BODY, AND HYDRAULIC SYSTEM

CHANGES TO BIDDER'S EVALUATION REPORT:

NO CHANGE REQUIRED: Change of Bid Opening Date

FROM:

X9.0.3 Front body bulkhead: ___ inch AR400 steel ___ PSI yield strength

TO:

X9.0.3 Front body bulkhead: 3/16 inch AR400 steel

FROM:

X9.2.1 Floor: ___ inch AR400 ___ PSI yield strength with ___ degree knee brace welded to floor

TO:

X9.2.1 Floor: 1/4 inch AR400 steel with 45 degree knee brace welded to floor

Is body crossmemberless type X YES NO

FROM:

X9.2.2 Sides: ___ Gauge AR400 ___ PSI yield strength steel thickness

TO:

X9.2.2 Sides: 10 Gauge AR400 steel thickness

FROM:

X9.2.3 Tailgate Plate: ___ inch AR400 ___ PSI yield strength steel

TO:

X9.2.3 Tailgate Plate: 3/16 inch AR400 steel

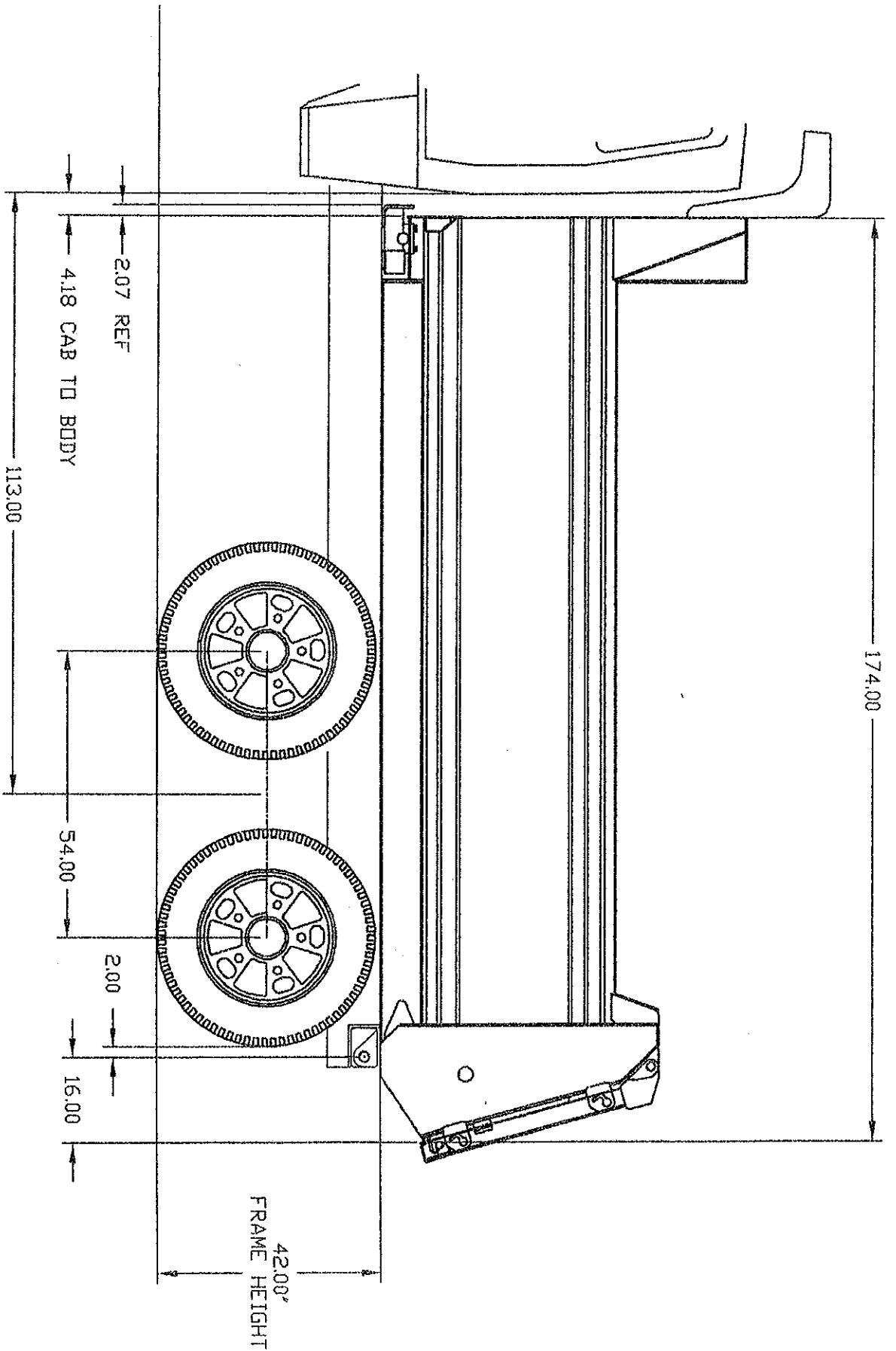

MKE ASPHALT BODY
WV 16" OVERHANG

State of West Virginia VENDOR PREFERENCE CERTIFICATE

Certification and application* is hereby made for Preference in accordance with *West Virginia Code*, §5A-3-37. (Does not apply to construction contracts). *West Virginia Code*, §5A-3-37, provides an opportunity for qualifying vendors to request (at the time of bid) preference for their residency status. Such preference is an evaluation method only and will be applied only to the cost bid in accordance with the *West Virginia Code*. This certificate for application is to be used to request such preference. The Purchasing Division will make the determination of the Resident Vendor Preference, if applicable.

- 1. **Application is made for 2.5% resident vendor preference for the reason checked:**
 Bidder is an individual resident vendor and has resided continuously in West Virginia for four (4) years immediately preceding the date of this certification; or,
 Bidder is a partnership, association or corporation resident vendor and has maintained its headquarters or principal place of business continuously in West Virginia for four (4) years immediately preceding the date of this certification; or 80% of the ownership interest of Bidder is held by another individual, partnership, association or corporation resident vendor who has maintained its headquarters or principal place of business continuously in West Virginia for four (4) years immediately preceding the date of this certification; or,
 Bidder is a nonresident vendor which has an affiliate or subsidiary which employs a minimum of one hundred state residents and which has maintained its headquarters or principal place of business within West Virginia continuously for the four (4) years immediately preceding the date of this certification; or,
- 2. **Application is made for 2.5% resident vendor preference for the reason checked:**
 Bidder is a resident vendor who certifies that, during the life of the contract, on average at least 75% of the employees working on the project being bid are residents of West Virginia who have resided in the state continuously for the two years immediately preceding submission of this bid; or,
- 3. **Application is made for 2.5% resident vendor preference for the reason checked:**
 Bidder is a nonresident vendor employing a minimum of one hundred state residents or is a nonresident vendor with an affiliate or subsidiary which maintains its headquarters or principal place of business within West Virginia employing a minimum of one hundred state residents who certifies that, during the life of the contract, on average at least 75% of the employees or Bidder's affiliate's or subsidiary's employees are residents of West Virginia who have resided in the state continuously for the two years immediately preceding submission of this bid; or,
- 4. **Application is made for 5% resident vendor preference for the reason checked:**
 Bidder meets either the requirement of both subdivisions (1) and (2) or subdivision (1) and (3) as stated above; or,
- 5. **Application is made for 3.5% resident vendor preference who is a veteran for the reason checked:**
 Bidder is an individual resident vendor who is a veteran of the United States armed forces, the reserves or the National Guard and has resided in West Virginia continuously for the four years immediately preceding the date on which the bid is submitted; or,
- 6. **Application is made for 3.5% resident vendor preference who is a veteran for the reason checked:**
 Bidder is a resident vendor who is a veteran of the United States armed forces, the reserves or the National Guard, if, for purposes of producing or distributing the commodities or completing the project which is the subject of the vendor's bid and continuously over the entire term of the project, on average at least seventy-five percent of the vendor's employees are residents of West Virginia who have resided in the state continuously for the two immediately preceding years.

Bidder understands if the Secretary of Revenue determines that a Bidder receiving preference has failed to continue to meet the requirements for such preference, the Secretary may order the Director of Purchasing to: (a) reject the bid; or (b) assess a penalty against such Bidder in an amount not to exceed 5% of the bid amount and that such penalty will be paid to the contracting agency or deducted from any unpaid balance on the contract or purchase order.

By submission of this certificate, Bidder agrees to disclose any reasonably requested information to the Purchasing Division and authorizes the Department of Revenue to disclose to the Director of Purchasing appropriate information verifying that Bidder has paid the required business taxes, provided that such information does not contain the amounts of taxes paid nor any other information deemed by the Tax Commissioner to be confidential.

Under penalty of law for false swearing (*West Virginia Code*, §61-5-3), Bidder hereby certifies that this certificate is true and accurate in all respects; and that if a contract is issued to Bidder and if anything contained within this certificate changes during the term of the contract, Bidder will notify the Purchasing Division in writing immediately.

Bidder: MATHENY MOTOR TRUCK CO. Signed: *Mif Matheny*
 Date: 2/15/11 Title: CEO

*Check any combination of preference consideration(s) indicated above, which you are entitled to receive.

RFQ No. 7011EC10

STATE OF WEST VIRGINIA
Purchasing Division

PURCHASING AFFIDAVIT

West Virginia Code §5A-3-10a states: No contract or renewal of any contract may be awarded by the state or any of its political subdivisions to any vendor or prospective vendor when the vendor or prospective vendor or a related party to the vendor or prospective vendor is a debtor and the debt owed is an amount greater than one thousand dollars in the aggregate.

DEFINITIONS:

"Debt" means any assessment, premium, penalty, fine, tax or other amount of money owed to the state or any of its political subdivisions because of a judgment, fine, permit violation, license assessment, defaulted workers' compensation premium, penalty or other assessment presently delinquent or due and required to be paid to the state or any of its political subdivisions, including any interest or additional penalties accrued thereon.

"Debtor" means any individual, corporation, partnership, association, limited liability company or any other form or business association owing a debt to the state or any of its political subdivisions. "Political subdivision" means any county commission; municipality; county board of education; any instrumentality established by a county or municipality; any separate corporation or instrumentality established by one or more counties or municipalities, as permitted by law; or any public body charged by law with the performance of a government function or whose jurisdiction is coextensive with one or more counties or municipalities. "Related party" means a party, whether an individual, corporation, partnership, association, limited liability company or any other form or business association or other entity whatsoever, related to any vendor by blood, marriage, ownership or contract through which the party has a relationship of ownership or other interest with the vendor so that the party will actually or by effect receive or control a portion of the benefit, profit or other consideration from performance of a vendor contract with the party receiving an amount that meets or exceeds five percent of the total contract amount.

EXCEPTION: The prohibition of this section does not apply where a vendor has contested any tax administered pursuant to chapter eleven of this code, workers' compensation premium, permit fee or environmental fee or assessment and the matter has not become final or where the vendor has entered into a payment plan or agreement and the vendor is not in default of any of the provisions of such plan or agreement.

Under penalty of law for false swearing (*West Virginia Code §61-5-3*), it is hereby certified that the vendor affirms and acknowledges the information in this affidavit and is in compliance with the requirements as stated.

WITNESS THE FOLLOWING SIGNATURE

Vendor's Name: MATHENY MOTOR TRUCK CO.

Authorized Signature: *Mr. J. Matheny* Date: 2/15/11

State of WV

County of Wood, to-wit:

Taken, subscribed, and sworn to before me this 15 day of FEBRUARY, 2011

My Commission expires 10/26/2012

AFFIX SEAL HERE

NOTARY PUBLIC

Clara L. Fowler

