



State of West Virginia  
 Department of Administration  
 Purchasing Division  
 2019 Washington Street East  
 Post Office Box 50130  
 Charleston, WV 25305-0130

# Request for Quotation

RFQ NUMBER  
**7011EC05**

PAGE  
**1**

ADDRESS CORRESPONDENCE TO ATTENTION OF:  
**BUYER 33**  
**304-558-2402**

**VENDOR**  
 \*709015804      724-437-1578  
 UNIONTOWN INDUSTRIAL EQUIP CO  
 2266 UNIVERSITY DR  
 LEMONT FURNACE PA 15478

**SHIP TO**  
 DIVISION OF HIGHWAYS  
 EQUIPMENT DIVISION  
 ROUTE 33  
 BRUSHY FORK ROAD  
 BUCKHANNON, WV  
 26201      304-472-1750

DATE PRINTED	TERMS OF SALE	SHIP VIA	F.O.B.	FREIGHT TERMS
09/29/2010				

BID OPENING DATE: **11/10/2010**      BID OPENING TIME **01:30PM**

LINE	QUANTITY	UOP	CAT. NO.	ITEM NUMBER	UNIT PRICE	AMOUNT
0001	1	EA		760-75	\$28,873.00	\$28,873.00
<p>DOUBLE DRUM VIBRATORY ROLLER/COMPACTOR</p> <p>OPEN END CONTRACT</p> <p>TO PROVIDE DOUBLE DRUM VIBRATORY ROLLER/COMPACTOR FOR THE WEST VIRGINIA DIVISION OF HIGHWAYS. PER THE ATTACHED SPECIFICATIONS.</p> <p>MANDATORY PRE-BID</p> <p>A MANDATORY PRE-BID WILL BE HELD ON THURSDAY, 10/28. AT 10 AM, 2019 WASHINGTON ST E., CHARLESTON WV 25305. ALL INTERESTED PARTIES ARE REQUIRED TO ATTEND THIS MEETING FAILURE TO ATTEND THE MANDATORY PRE-BID SHALL RESULT IN DISQUALIFICATION OF THE BID. NO ONE PERSON MAY REPRESENT MORE THAN ONE BIDDER.</p> <p>AN ATTENDANCE SHEET WILL BE MADE AVAILABLE FOR ALL POTENTIAL BIDDERS TO COMPLETE. THIS WILL SERVE AS THE OFFICIAL DOCUMENT VERIFYING ATTENDANCE AT THE MANDATORY PRE-BID. FAILURE TO PROVIDE YOUR COMPANY AND REPRESENTATIVE NAME ON THE ATTENDANCE SHEET WILL RESULT IN DISQUALIFICATION OF THE BID. THE STATE WILL NOT ACCEPT ANY OTHER DOCUMENTATION TO VERIFY ATTENDANCE. THE BIDDER IS RESPONSIBLE FOR ENSURING THEY HAVE COMPLETED THE INFORMATION REQUIRED ON THE ATTENDANCE SHEET. THE PURCHASING DIVISION AND THE STATE AGENCY WILL NOT ASSUME ANY RESPONSIBILITY FOR A BIDDER-S FAILURE TO COMPLETE THE PRE-BID ATTENDANCE SHEET. IN ADDITION, WE REQUEST THAT ALL POTENTIAL BIDDERS INCLUDE THEIR E-MAIL ADDRESS AND FAX NUMBER.</p>						

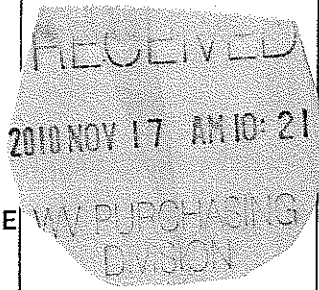

SEE REVERSE SIDE FOR TERMS AND CONDITIONS

SIGNATURE: *Michael W. [Signature]*      TELEPHONE: (724) 437-1578      DATE: 11/08/10

TITLE: V.Pres.      FEIN: 25-1389795      ADDRESS CHANGES TO BE NOTED ABOVE

WHEN RESPONDING TO RFQ, INSERT NAME AND ADDRESS IN SPACE ABOVE LABELED 'VENDOR'

**GENERAL TERMS & CONDITIONS**  
**REQUEST FOR QUOTATION (RFQ) AND REQUEST FOR PROPOSAL (RFP)**

1. Awards will be made in the best interest of the State of West Virginia.
2. The State may accept or reject in part, or in whole, any bid.
3. Prior to any award, the apparent successful vendor must be properly registered with the Purchasing Division and have paid the required \$125 fee.
4. All services performed or goods delivered under State Purchase Order/Contracts are to be continued for the term of the Purchase Order/Contracts, contingent upon funds being appropriated by the Legislature or otherwise being made available. In the event funds are not appropriated or otherwise available for these services or goods this Purchase Order/Contract becomes void and of no effect after June 30.
5. Payment may only be made after the delivery and acceptance of goods or services.
6. Interest may be paid for late payment in accordance with the *West Virginia Code*.
7. Vendor preference will be granted upon written request in accordance with the *West Virginia Code*.
8. The State of West Virginia is exempt from federal and state taxes and will not pay or reimburse such taxes.
9. The Director of Purchasing may cancel any Purchase Order/Contract upon 30 days written notice to the seller.
10. The laws of the State of West Virginia and the *Legislative Rules* of the Purchasing Division shall govern the purchasing process.
11. Any reference to automatic renewal is hereby deleted. The Contract may be renewed only upon mutual written agreement of the parties.
12. **BANKRUPTCY:** In the event the vendor/contractor files for bankruptcy protection, the State may deem this contract null and void, and terminate such contract without further order.
13. **HIPAA BUSINESS ASSOCIATE ADDENDUM:** The West Virginia State Government HIPAA Business Associate Addendum (BAA), approved by the Attorney General, is available online at [www.state.wv.us/admin/purchase/vrc/hipaa.htm](http://www.state.wv.us/admin/purchase/vrc/hipaa.htm) and is hereby made part of the agreement. Provided that the Agency meets the definition of a Cover Entity (45 CFR §160.103) and will be disclosing Protected Health Information (45 CFR §160.103) to the vendor.
14. **CONFIDENTIALITY:** The vendor agrees that he or she will not disclose to anyone, directly or indirectly, any such personally identifiable information or other confidential information gained from the agency, unless the individual who is the subject of the information consents to the disclosure in writing or the disclosure is made pursuant to the agency's policies, procedures, and rules. Vendor further agrees to comply with the Confidentiality Policies and Information Security Accountability Requirements, set forth in <http://www.state.wv.us/admin/purchase/privacy/noticeConfidentiality.pdf>.
15. **LICENSING:** Vendors must be licensed and in good standing in accordance with any and all state and local laws and requirements by any state or local agency of West Virginia, including, but not limited to, the West Virginia Secretary of State's Office, the West Virginia Tax Department, and the West Virginia Insurance Commission. The vendor must provide all necessary releases to obtain information to enable the director or spending unit to verify that the vendor is licensed and in good standing with the above entities.
16. **ANTITRUST:** In submitting a bid to any agency for the State of West Virginia, the bidder offers and agrees that if the bid is accepted the bidder will convey, sell, assign or transfer to the State of West Virginia all rights, title and interest in and to all causes of action it may now or hereafter acquire under the antitrust laws of the United States and the State of West Virginia for price fixing and/or unreasonable restraints of trade relating to the particular commodities or services purchased or acquired by the State of West Virginia. Such assignment shall be made and become effective at the time the purchasing agency tenders the initial payment to the bidder.

I certify that this bid is made without prior understanding, agreement, or connection with any corporation, firm, limited liability company, partnership, or person or entity submitting a bid for the same material, supplies, equipment or services and is in all respects fair and without collusion or fraud. I further certify that I am authorized to sign the certification on behalf of the bidder or this bid.

**INSTRUCTIONS TO BIDDERS**

1. Use the quotation forms provided by the Purchasing Division. Complete all sections of the quotation form.
2. Items offered must be in compliance with the specifications. Any deviation from the specifications must be clearly indicated by the bidder. Alternates offered by the bidder as **EQUAL** to the specifications must be clearly defined. A bidder offering an alternate should attach complete specifications and literature to the bid. The Purchasing Division may waive minor deviations to specifications.
3. Unit prices shall prevail in case of discrepancy. All quotations are considered F.O.B. destination unless alternate shipping terms are clearly identified in the quotation.
4. All quotations must be delivered by the bidder to the office listed below prior to the date and time of the bid opening. Failure of the bidder to deliver the quotations on time will result in bid disqualifications: Department of Administration, Purchasing Division, 2019 Washington Street East, P.O. Box 50130, Charleston, WV 25305-0130
5. Communication during the solicitation, bid, evaluation or award periods, except through the Purchasing Division, is strictly prohibited (W.Va. C.S.R. §148-1-6.6).



State of West Virginia  
 Department of Administration  
 Purchasing Division  
 2019 Washington Street East  
 Post Office Box 50130  
 Charleston, WV 25305-0130

# Request for Quotation

RFQ NUMBER  
**7011EC05**

PAGE  
**2**

ADDRESS CORRESPONDENCE TO ATTENTION OF  
**BUYER 33**  
**304-558-2402**

**VENDOR**  
 \*709015804      724-437-1578  
 UNIONTOWN INDUSTRIAL EQUIP CO  
 2266 UNIVERSITY DR  
  
 LEMONT FURNACE PA 15478

**SHIP TO**  
 DIVISION OF HIGHWAYS  
 EQUIPMENT DIVISION  
 ROUTE 33  
 BRUSHY FORK ROAD  
 BUCKHANNON, WV  
 26201      304-472-1750

DATE PRINTED	TERMS OF SALE	SHIP VIA	F.O.B.	FREIGHT TERMS
09/29/2010				

BID OPENING DATE: **11/10/2010**      BID OPENING TIME **01:30PM**

LINE	QUANTITY	UOP	CAT NO	ITEM NUMBER	UNIT PRICE	AMOUNT
<p>ALL POTENTIAL BIDDERS ARE REQUESTED TO ARRIVE PRIOR TO THE STARTING TIME FOR THE PRE-BID. BIDDERS WHO ARRIVE LATE, BUT PRIOR TO THE DISMISSAL OF THE TECHNICAL PORTION OF THE PRE-BID WILL BE PERMITTED TO SIGN IN. BIDDERS WHO ARRIVE AFTER CONCLUSION OF THE TECHNICAL PORTION OF THE PRE-BID, BUT DURING ANY SUBSEQUENT PART OF THE PRE-BID WILL NOT BE PERMITTED TO SIGN THE ATTENDANCE SHEET.</p> <p>QUESTIONS: WRITTEN QUESTIONS WILL BE ACCEPTED THROUGH CLOSE OF BUSINESS (5:00 PM, EST) ON THURSDAY, 10/21/10.</p> <p>SEND QUESTIONS TO: PURCHASING DIVISION            ATTENTION SHERI SLONE/CHUCK BOWMAN            2019 WASHINGTON STREET EAST            CHARLESTON, WV 25305</p> <p>QUESTIONS MAY BE SENT VIA FAX, E-MAIL, OR REGULAR MAIL.            E-MAIL: SHERI.D.SLONE@WV.GOV            FAX: 304-558-4115</p> <p>IT IS THE VENDOR'S RESPONSIBILITY TO VERIFY THAT THEIR QUESTIONS HAVE BEEN RECEIVED BY CALLING 304-558-2402.</p> <p>EXHIBIT 2</p> <p>LIFE OF CONTRACT: THIS CONTRACT BECOMES EFFECTIVE ON ..... AND EXTENDS FOR A PERIOD OF ONE (1) YEAR OR UNTIL SUCH "REASONABLE TIME" THEREAFTER AS IS NECESSARY TO OBTAIN A NEW CONTRACT OR RENEW THE ORIGINAL CONTRACT. THE "REASONABLE TIME" PERIOD SHALL NOT EXCEED TWELVE (12) MONTHS. DURING THIS "REASONABLE TIME" THE VENDOR MAY TERMINATE THIS CONTRACT FOR</p>						

SEE REVERSE SIDE FOR TERMS AND CONDITIONS			
SIGNATURE <i>Michael W. ...</i>	TELEPHONE (724) 437-1578	DATE 11/08/10	
TITLE V.Pres.	FAX 25-1389795	ADDRESS CHANGES TO BE NOTED ABOVE	

WHEN RESPONDING TO RFQ. INSERT NAME AND ADDRESS IN SPACE ABOVE LABELED 'VENDOR'



State of West Virginia  
 Department of Administration  
 Purchasing Division  
 2019 Washington Street East  
 Post Office Box 50130  
 Charleston, WV 25305-0130

**Request for  
 Quotation**

RFQ NUMBER
7011EC05

PAGE
3

ADDRESS CORRESPONDENCE TO ATTENTION OF
BUYER 33 304-558-2402

**VENDOR**  
 \*709015804 724-437-1578  
 UNIONTOWN INDUSTRIAL EQUIP CO  
 2266 UNIVERSITY DR  
 LEMONT FURNACE PA 15478

**SHIP TO**  
 DIVISION OF HIGHWAYS  
 EQUIPMENT DIVISION  
 ROUTE 33  
 BRUSHY FORK ROAD  
 BUCKHANNON, WV  
 26201 304-472-1750

DATE PRINTED	TERMS OF SALE	SHIP VIA	F.O.B.	FREIGHT TERMS
09/29/2010				

BID OPENING DATE: 11/10/2010 BID OPENING TIME 01:30PM

LINE	QUANTITY	UOP	CAT NO	ITEM NUMBER	UNIT PRICE	AMOUNT
<p>ANY REASON UPON GIVING THE DIRECTOR OF PURCHASING THIRTY (30) DAYS WRITTEN NOTICE.</p> <p>UNLESS SPECIFIC PROVISIONS ARE STIPULATED IN THIS CONTRACT DOCUMENT, THE TERMS, CONDITIONS, AND PRICING SET HEREIN ARE FIRM FOR THE LIFE OF THE CONTRACT.</p> <p>RENEWAL: THIS CONTRACT MAY BE RENEWED UPON THE MUTUAL WRITTEN CONSENT OF THE SPENDING UNIT AND VENDOR, SUBMITTED TO THE DIRECTOR OF PURCHASING THIRTY (30) DAYS PRIOR TO THE EXPIRATION DATE. SUCH RENEWAL SHALL BE IN ACCORDANCE WITH THE TERMS AND CONDITIONS OF THE ORIGINAL CONTRACT AND SHALL BE LIMITED TO TWO (2) ONE (1) YEAR PERIODS.</p> <p>CANCELLATION: THE DIRECTOR OF PURCHASING RESERVES THE RIGHT TO CANCEL THIS CONTRACT IMMEDIATELY UPON WRITTEN NOTICE TO THE VENDOR IF THE COMMODITIES AND/OR SERVICE SUPPLIED ARE OF AN INFERIOR QUALITY OR DO NOT CONFORM WITH THE SPECIFICATIONS OF THE BID AND CONTRACT HEREIN.</p> <p>OPEN MARKET CLAUSE: THE DIRECTOR OF PURCHASING MAY AUTHORIZE A SPENDING UNIT TO PURCHASE ON THE OPEN MARKET, WITHOUT THE FILING OF A REQUISITION OR COST ESTIMATE, ITEMS SPECIFIED ON THIS CONTRACT FOR IMMEDIATE DELIVERY IN EMERGENCIES DUE TO UNFORESEEN CAUSES (INCLUDING BUT NOT LIMITED TO DELAYS IN TRANSPORTATION OR AN UNANTICIPATED INCREASE IN THE VOLUME OF WORK).</p> <p>QUANTITIES: QUANTITIES LISTED IN THE REQUISITION ARE APPROXIMATIONS ONLY, BASED ON ESTIMATES SUPPLIES BY THE STATE SPENDING UNIT. IT IS UNDERSTOOD AND AGREED THAT THE CONTRACT SHALL COVER THE QUANTITIES ACTUALLY ORDERED FOR DELIVERY DURING THE TERM OF CONTRACT, WHETHER MORE OR LESS THAN THE QUANTITIES SHOWN.</p>						

SIGNATURE <i>Michael W. Allen</i>				TELEPHONE (724) 437-1578		DATE 11/08/10
TITLE V.Pres.	FEIN 25-1389795	ADDRESS CHANGES TO BE NOTED ABOVE				

WHEN RESPONDING TO RFQ, INSERT NAME AND ADDRESS IN SPACE ABOVE LABELED 'VENDOR'



State of West Virginia  
 Department of Administration  
 Purchasing Division  
 2019 Washington Street East  
 Post Office Box 50130  
 Charleston, WV 25305-0130

# Request for Quotation

RFQ NUMBER  
**7011EC05**

PAGE  
**4**

ADDRESS CORRESPONDENCE TO ATTENTION OF  
**BUYER 33**  
**304-558-2402**

VENDOR

\*709015804      724-437-1578  
 UNIONTOWN INDUSTRIAL EQUIP CO  
 2266 UNIVERSITY DR  
  
 LEMONT FURNACE PA 15478

SHIP TO

DIVISION OF HIGHWAYS  
 EQUIPMENT DIVISION  
 ROUTE 33  
 BRUSHY FORK ROAD  
 BUCKHANNON, WV  
 26201      304-472-1750

DATE PRINTED	TERMS OF SALE	SHIP VIA	F.O.B.	FREIGHT TERMS
09/29/2010				

BID OPENING DATE: **11/10/2010**      BID OPENING TIME **01:30PM**

LINE	QUANTITY	UOP	CAT NO	ITEM NUMBER	UNIT PRICE	AMOUNT
<p>ORDERING PROCEDURE: SPENDING UNIT(S) SHALL ISSUE A WRITTEN EQUIPMENT CONTRACT ORDER (FORM NUMBER WV-35) FOR COMMODITIES COVERED BY THIS CONTRACT. THE ORIGINAL WV-35 MUST BE SENT TO THE PURCHASING DIVISION OF THE DEPARTMENT OF ADMINISTRATION. AFTER APPROVAL AND ENCUMBRANCE, ONE COPY OF THE PURCHASE ORDER WILL BE RETURNED TO THE SPENDING UNIT AND ONE COPY FORWARDED TO THE VENDOR AS AUTHORIZATION FOR SHIPMENT. NO ORDER IS VALID UNLESS APPROVED AND ENCUMBERED BY THE PURCHASING DIVISION.</p> <p>BANKRUPTCY: IN THE EVENT THE VENDOR/CONTRACTOR FILES FOR BANKRUPTCY PROTECTION, THE STATE MAY DEEM THE CONTRACT NULL AND VOID, AND TERMINATE SUCH CONTRACT WITHOUT FUTHER ORDER.</p> <p>REV. 5/2009</p> <p>EXHIBIT 10</p> <p style="text-align: right;">REQUISITION NO.: 7011EC05....</p> <p>ADDENDUM ACKNOWLEDGEMENT</p> <p>I HEREBY ACKNOWLEDGE RECEIPT OF THE FOLLOWING CHECKED ADDENDUM(S) AND HAVE MADE THE NECESSARY REVISIONS TO MY PROPOSAL, PLANS AND/OR SPECIFICATION, ETC.</p> <p>ADDENDUM NO.'S:</p> <p>NO. 1 ..... X</p> <p>NO. 2 .....</p> <p>NO. 3 .....</p>						

SEE REVERSE SIDE FOR TERMS AND CONDITIONS

SIGNATURE <i>Michael W. [Signature]</i>	TELEPHONE (724) 437-1578	DATE 11/08/10
TITLE V.Pres.	FEIN 25-1389795	ADDRESS CHANGES TO BE NOTED ABOVE



State of West Virginia  
 Department of Administration  
 Purchasing Division  
 2019 Washington Street East  
 Post Office Box 50130  
 Charleston, WV 25305-0130

# Request for Quotation

RFQ NUMBER  
**7011EC05**

PAGE  
**5**

ADDRESS CORRESPONDENCE TO ATTENTION OF:  
**BUYER 33  
 304-558-2402**

VENDOR

\*709015804      724-437-1578  
 UNIONTOWN INDUSTRIAL EQUIP CO  
 2266 UNIVERSITY DR  
 LEMONT FURNACE PA 15478

SHIP TO

DIVISION OF HIGHWAYS  
 EQUIPMENT DIVISION  
 ROUTE 33  
 BRUSHY FORK ROAD  
 BUCKHANNON, WV  
 26201      304-472-1750

DATE PRINTED <b>09/29/2010</b>	TERMS OF SALE	SHIP VIA	FOB	FREIGHT TERMS
-----------------------------------	---------------	----------	-----	---------------

BID OPENING DATE: **11/10/2010**      BID OPENING TIME **01:30PM**

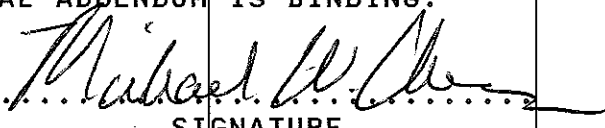
LINE	QUANTITY	UOP	CAT NO	ITEM NUMBER	UNIT PRICE	AMOUNT
	NO. 4 .....					
	NO. 5 .....					
<p>I UNDERSTAND THAT FAILURE TO CONFIRM THE RECEIPT OF TH ADDENDUM(S) MAY BE CAUSE FOR REJECTION OF BIDS.</p> <p>VENDOR MUST CLEARLY UNDERSTAND THAT ANY VERBAL REPRESENTATION MADE OR ASSUMED TO BE MADE DURING ANY ORAL DISCUSSION HELD BETWEEN VENDOR'S REPRESENTATIVES AND ANY STATE PERSONNEL IS NOT BINDING. ONLY THE INFORMATION ISSUED IN WRITING AND ADDED TO THE SPECIFICATIONS BY AN OFFICIAL ADDENDUM IS BINDING.</p> <p style="text-align: center;">             SIGNATURE            Uniontown Industrial Equipment Co. Inc.            COMPANY            November 08, 2010            DATE         </p> <p>NOTE: THIS ADDENDUM ACKNOWLEDGEMENT SHOULD BE SUBMITTED WITH THE BID.</p> <p>REV. 09/21/2009</p> <p>EXHIBIT 4</p> <p>LOCAL GOVERNMENT BODIES: UNLESS THE VENDOR INDICATES IN THE BID HIS REFUSAL TO EXTEND THE PRICES, TERMS,</p>						

SEE REVERSE SIDE FOR TERMS AND CONDITIONS

SIGNATURE 	TELEPHONE (724) 437-1578	DATE 11/08/10
TITLE V. PRES.	FEIN 25-1389795	ADDRESS CHANGES TO BE NOTED ABOVE

WHEN RESPONDING TO RFQ, INSERT NAME AND ADDRESS IN SPACE ABOVE LABELED 'VENDOR'







WEST VIRGINIA DEPARTMENT OF TRANSPORTATION  
DIVISION OF HIGHWAYS  
EQUIPMENT DIVISION

PROCUREMENT SPECIFICATIONS  
NO. 591-2-M

OPEN END CONTRACT  
DOUBLE DRUM VIBRATORY ROLLER/COMPACTOR

1.0 PURPOSE

It is the purpose of these specifications to describe a Double Drum Vibratory Roller/Compactor (hereinafter referred to as a "roller" or a "unit") to be purchased for use by the West Virginia Division of Highways (DOH) on an Open End Contract basis.

2.0 BIDDING PROCEDURES

**The current purchasing procedures regarding bidding as established by the Department of Administration, Purchasing Division, shall apply. Failure to submit the "Request for Quotation" forms, complete in its entirety and according to directions indicated, may subject the bidder to disqualification. Each bid submitted shall also be accompanied by a Bidder's Evaluation Report completed in detail. Addendums in order, along with exception sheets, should be with Bidder's Evaluation Report. FAILURE TO SUBMIT THE BIDDER'S EVALUATION REPORT, COMPLETE IN ITS ENTIRETY, SHALL RESULT IN AUTOMATIC DISQUALIFICATION.**

3.0 SPECIFICATIONS

The specifications named herein, mandatory and non-mandatory, establish the acceptable level of quality only and are not intended to reflect a preference or favor any particular brand or vendor.

3.1 EXCEPTIONS TO NON-MANDATORY SPECIFICATIONS

Exception to a non-mandatory unit specification may be made by the bidder, providing the exception is not available from the manufacturer. **Any such exception must be noted on the bidder's evaluation report and should be accompanied by supporting documentation/literature from the manufacturer. Any exception must be indicated on a separate attachment to the bidder's evaluation report and labeled as "Exception to Specifications".** The state reserves the right to determine whether the stated exception does or does not reduce the quality and performance of the unit. Failure to provide information for any exceptions may be grounds for rejection of the bid. The state reserves the right to waive minor irregularities in bids or specifications in accordance with §148-1-4(f) of the WV Legislative Rules and Regulations.

### 3.2 MANDATORY SPECIFICATIONS

All specifications preceded by "shall, will, and/or must" or are stated as a "minimum and/or maximum" are mandatory as stated in Purchasing Divisions Policies and Procedures. Any bid failing to meet any mandatory item shall be immediately disqualified. Failure to respond in the appropriate evaluation section may also be grounds for immediate disqualification at the discretion of the State.

A mandatory pre-bid conference is scheduled for this equipment purchase as stated in the RFQ. Vendors having products with variations or exceptions in specified mandatory items are expected to address any such variations or exceptions during the pre-bid conference. The State shall review and consider any such variation or exception, and may at its sole discretion, issue an addendum to change mandatory specifications deemed to be in the State's best interest. Bids from any vendor failing to attend the mandatory pre-bid shall be disqualified. Bids containing any variation or exception to a mandatory specification that was not addressed during the pre-bid conference and accepted by the issuance of an Addendum shall be disqualified.

### 4.0 REPRESENTATIVE UNIT FOR TEST

The successful vendor must (if specified) provide DOH one (1) completed representative unit to be observed and evaluated on each order to insure compliance with specification. If requested, the time period for testing and evaluation shall be seven (7) working days following receipt of the unit. DOH will incur no obligation for deterioration of surfaces, finishes, seals, and mechanical or electrical parts on the unit resulting from operation and testing within the limits of these specifications; nor will DOH incur obligation for damage to the unit resulting from failure to meet specifications when due care and attention is given by DOH and testing is done within the limits of these specifications. Failure of the pilot unit to satisfactorily meet specifications as bid shall be cause for cancellation of the purchase order, and return of the delivered unit along with all associated equipment to the vendor at the vendor's expense.

#### 4.1 CONDITION OF UNIT(S) UPON DELIVERY

All units must arrive at the prescribed delivery point having been completely preserviced with oil, lubricants, and coolant. All prescribed precautions pertaining to first operations and break-in of the unit are to be posted conspicuously on the unit for ready observance by the operator.

#### 4.2 DELIVERY

Delivery point of the completely assembled representative unit will be the DOH, Equipment Division, Route 33 at Brushy Fork Road, Buckhannon, West Virginia (26201).

The vendor is responsible for guaranteeing delivery of the completed units within the time specified and agreed to by the State. Delivery is preferred within 120 days after

receipt of purchase agreement. The vendor is responsible for establishing and coordinating delivery terms with allied manufacturers or suppliers. **Delivery terms shall be stated in the bid and the State reserves the right to accept or negotiate such terms.** Failure to reach an agreement may result in rejection of the bid. **The successful bidder shall provide their manufacturer's confirmation of the order to the WVDOH contact person within seven (7) working days after receiving the approved purchase order.**

**A completed pilot model for inspection must be provided within 45 calendar days after receipt of the purchase agreement by the successful vendor.**

Delivery is an integral part of this specification and failure to comply will be cause to initiate a D.O.T. Administrative Form WV-82, Vendor Performance Form. The WV-82 Form will provide a means of officially notifying the Purchasing Division and the vendor of unsatisfactory performance; such as late deliveries, poor service, inadequate parts supplies, etc.

The decision to initiate subject Form will be at the sole discretion of the D.O.H. Commissioner's established Equipment Review Board.

Issuance of the WV-82 Vendor Complaint Form on unsatisfactory delivery against any vendor will be cause to refuse to consider similar items from those vendors on future Request For Quotations.

(NOTE: Delivery time could be altered due to labor strikes, severe inclement weather conditions, etc.)

## 5.0 AWARD CRITERIA

- 5.1 DOH will recommend the award in accordance with the RFQ evaluation criteria described in the requisition. **The award shall be made to the lowest unit cost vendor that meets or exceeds the specifications.** DOH reserves the right to place multiple orders in any quantity.

## 6.0 SPECIFICATIONS AND GUIDELINES - GENERAL

### 6.1 IDENTIFICATION OF THE UNIT BEING PROPOSED

**The bidder must identify the unit by manufacturer, model, series, and year of manufacture, in the bid to enable identification by DOH in the manufacturer's specifications of the proposed unit.** The bidder will submit complete descriptive literature of the proposed unit, to establish that the bid is the manufacturer's most current model, including latest engineering improvements, which have been, or will imminently be, regularly advertised and sold on the open market. The unit specified herein and offered to be manufactured after January 1, 2010 and be clearly identified and marked with date of manufacture.

## 6.2 OPERATING AND SERVICE MANUALS AND PARTS LISTS

An operator's manual must be included with each unit upon delivery. A "line sheet" (if applicable) and Equipment Preventative Maintenance Questionnaire (as shown in X6.2 of the Bidder's Evaluation Report) must be with pilot unit upon delivery. In addition, there must be 12 service, shop, or maintenance manuals; ten (10) to be distributed to the Districts and two (2) for the Equipment Division. Also, there must be 14 parts manuals; ten (10) to be distributed to the Districts and four (4) for Equipment Division use. CD ROM is preferred in lieu of parts or service manuals.

\* NOTE: MANUALS SHALL BE DELIVERED UPON COMPLETION OF DELIVERY OF TOTAL UNITS. FAILURE TO DO SO WILL DELAY PAYMENT.

## 6.3 TRAINING:

Manufacturers and/or dealers will be required to stage a thorough seminar on the subjects of Preventative Maintenance, Operator and Mechanic Training. In order to keep the operators and mechanics updated, the successful vendor shall conduct training with each purchase order against this open end contract. Training is preferred within 2 working days after delivery of the pilot unit on the individual purchase order.

Manufacturers and/or dealers shall be required to furnish the Training Academy with one (1) Operator's Manual to be shipped direct to WVDOH Training Academy, Post Office Box 610, Buckhannon, West Virginia 26201 prior to delivery of the pilot.

The seminar to be held at the W. Va. Division of Highways, Equipment Division, Buckhannon, West Virginia.

## 6.4 PREVENTIVE MAINTENANCE AND OPERATOR PROCEDURES:

Manufacturers and/or dealers will be required to submit to the Equipment Division, in addition to the operating and service manuals, booklets and pamphlets explaining the Preventive Maintenance and Operator Procedures to be used by the operators of this equipment, and must include such things as daily prestart inspection procedure, service schedule, and routine maintenance required, safety precautions, etc.

The successful vendor shall furnish all training aids; i.e., videos, projectors, etc. required in conducting the training.

## 6.5 WARRANTY AND SERVICE POLICY

The Manufacturers warranty or service policy is to apply to the unit. Such warranty or service policy is to be recognized at any authorized unit dealer, representing manufacturer of proposed unit throughout the State of West Virginia. The applicable

warranty or service policy will not be contingent upon obtaining routine service, lubrication, and servicing of the unit from factory authorized agencies. It will be the responsibility of the bidder to have available labor to repair or replace any defective replacement parts, components and materials, and to have available those replacement parts, components, and/or materials found to be defective during the terms of the warranty period. The bidder should state the labor rates, locations where parts will be stocked, availability of parts, and discounts offered for parts, when terms of the warranty offer a pro-rated cost for parts and labor. In addition, the successful bidder should offer field work to repair or replace defective parts, components, and materials found to be defective during the terms of the warranty and should provide mechanic's travel rates, mileage charges, field mechanic rates, and any surcharge for miscellaneous items, if applicable, for field work during the warranty period. Submit to Division of Highways any technical or engineering improvements during the term of the warranty. **The unit must be accompanied upon delivery by the unit's manufacturer's executed warranty or service policy.**

A mandatory minimum two (2) year bumper to bumper basic parts and labor warranty excluding abuse and normal wear items is required for this unit.

**THE "WARRANTY AND SERVICE POLICY QUESTIONNAIRE" ATTACHED IN THE BIDDER'S EVALUATION REPORT MUST BE COMPLETED IN ITS ENTIRETY BY THE SUCCESSFUL BIDDER OR MANUFACTURER PRIOR TO DELIVERY OF THE PILOT MODEL. (SEE SECTION X6.5 OF BIDDER'S EVALUATION REPORT).**

#### 6.6 EVALUATION COMMITTEE REQUIREMENTS

Detailed component specifications, product literature, component models, required for specification compliance determination by the Evaluation Committee should be provided with each bid. Any information supplied that is contrary to/or conflicting with the specifications and/or attached Bidders Evaluation Report may be sufficient cause for rejection of bid.

#### 6.7 UNSPECIFIED ACCESSORIES & FEATURES

All parts, equipment, accessories, material, design and performance characteristics not specified herein, but which are necessary to provide a complete unit, must be furnished with each unit and required to conform to strength, quality of material, and quality of workmanship to those which are advertised and provided to the market in general by the unit industry.

All parts and accessories advertised and regularly supplied as standard shall be included, except those which would represent duplication of these specified, and except those which, by specification, are not to be furnished. All standard safety features, required by Federal and State Law, shall be included.

- 7.0 SPECIFICATIONS OF THE QUOTED UNIT ARE AS FOLLOWS:
- 7.1 Roller(s) shall be equipped with ROPS and FOPS canopy.
- 7.2 Engine shall be manufacturers water/air cooled diesel powered and shall provide a minimum of 28 horsepower and sufficient torque to operate machine and hydraulic system at maximum efficiency.
- 7.3 Steering system shall be of hydraulic, full power, articulated design.
- 7.4 Unit shall be of a low profile design.
- 7.5 Unit weight to be approximately 6000 pounds.
- 7.6 Wheel base to be approximately 68 inches.
- 7.7 Roller(s) shall have dual drum drive with hydrostatic propulsion.
- 7.8 Unit shall be equipped with manufacturers vandalism package.
- 7.9 Unit shall travel 0 to 6 M.P.H. forward and reverse minimum.
- 7.10 Engine:
- 7.10.1 Engine to have a manufacturer's heaviest duty dual fuel filtering system offered.
- 7.10.2 Full pressure lubrication with oil filter and oil by-pass system.
- 7.10.3 Manufacturers standard governor with key shut off, wire sealed by manufacturer.
- 7.10.4 Cooling system shall be filled with permanent type Dex-Cool extended life (or equal) anti-freeze protected to a point of -34° F if unit is water cooled.
- 7.11 Brakes:
- 7.11.1 Service brake to be through hydrostatic propulsion system.
- 7.11.2 Parking brake to be of spring-applied, hydraulically released on each drum drive.

7.12 Drums:

- 7.12.1 Drums shall be of manufacturer's heavy duty design.
- 7.12.2 Drum width approximately 48 inches.
- 7.12.3 Drum diameter approximately 28 inches.
- 7.12.4 Wiper bars shall be mounted front and rear of each drum.
- 7.12.5 Wiper bars shall be spring loaded, self adjusting.
- 7.12.6 Wiper bars shall have replaceable rubber/neoprene drum cleaners.
- 7.12.7 Front and rear drums shall be of vibratory compaction type.
- 7.12.8 Vibrating parts must be isolated from rest of roller.
- 7.12.9 Vibrating system isolators shall be replaceable.
- 7.12.10 Unit must be equipped with automatic vibration switch.

7.13 Electrical:

- 7.13.1 Electrical system shall be manufacturer's heavy duty 12 volt D.C. negative ground.
- 7.13.2 Manufacturers recommended heavy duty maintenance free battery shall be provided.
- 7.13.3 Battery CCA 500 minimum.
- 7.13.4 Alternator to be 65 AMP with internal regulator.
- 7.14 Gauges to be illuminated and to be equipped with visual or audible warning that will advise operator when manufacturer recommended safe operating ranges are exceeded.
  - 7.14.1 Unit shall be provided with hour meter operable from engine operation (not key switch.)
  - 7.14.2 Ignition switch water sealed.
  - 7.14.3 Fuel gauge.

- 7.14.4 Volt/Amp meter gauge or light.
- 7.14.5 Oil pressure gauge or light.
- 7.14.6 Engine temperature gauge or light
- 7.14.7 Operators station to have manufacturer's fully adjustable isolation mounted seat with seat belt.
- 7.14.8 **OSHA approved back-up alarm shall be provided and installed by manufacturer.**
- 7.14.9 Unit to have a parking brake "on" indicator.
- 7.14.10 **A neutral start safety switch shall be provided.**
- 7.15 Water System:
  - 7.15.1 Tank capacity to be 50 gallon approximately.
  - 7.15.2 **Water system shall be pressurized.**
  - 7.15.3 **Water flow must be variable.**
  - 7.15.4 **Water filter(s) shall be provided in system.**
  - 7.15.5 Screened back nozzle type sprayers for drums.
  - 7.15.6 Empty water tank indicator to be provided.
  - 7.15.7 **Water pump shall be capable of "Run Dry" situation without damage to pump or components.**
  - 7.15.8 **Water tank and complete water system shall be constructed of rust proof materials.**
  - 7.15.9 **Water tank shall have drain plug.**
- 7.16 Lighting:
  - 7.16.1 **Unit shall be equipped with flashers visible from front and rear of roller.**
  - 7.16.2 **Work lights shall be installed front and rear of roller. Two (2) front and two (2) rear.**



- 7.16.3** Low profile high intensity dual flash strobe light shall be mounted on top of cab/canopy. Aero Flash Model number M420 or equivalent. (Amber in color)
- 7.17** Unit shall be delivered to WV DOH with all manufacturers recommended safety related decals and safety features intact.
- 7.18** One (1) complete set of replacement filters shall be provided with each unit upon delivery.
- 7.19** Paint:
- 7.19.1** The Manufacturer's recommended paint preparation and color to be provided.
- 7.20** Vendor must certify that roller offered will meet or exceed the "Occupational Safety and Health Act of 1970" or subsequent changes that are in effect at time of manufacturer of unit.
- 7.21** Advertising: Only one (1) manufacturer name plate, which must include model number, may appear on exterior of unit. Logos created through the stamping or casting process of manufacturer are also acceptable. No logo will interfere with the Department's striping and logo.
- 7.22** Preventive Maintenance and Operators Orientation/Training:
- 7.22.1** The Manufacturer or Dealer shall provide preventive maintenance/operator orientation seminar to be conducted at the Equipment Division, Buckhannon. The successful vendor shall furnish all training aids; i.e. videos, projectors, etc., required in conducting the training.

WEST VIRGINIA DEPARTMENT OF TRANSPORTATION  
DIVISION OF HIGHWAYS  
EQUIPMENT DIVISION

BIDDER'S EVALUATION REPORT

PROCUREMENT SPECIFICATIONS FOR OPEN END CONTRACT  
NO. 591-2-M

OPEN END CONTRACT  
DOUBLE DRUM VIBRATORY ROLLER/COMPACTOR

NOTE TO BIDDER: Procurement Specification No. 591-2-M, Paragraph 2.0 recommends the completion and submittal of this Report with your bid. Purpose of this Report is to enable the West Virginia Division of Highways Evaluation Committee to make full and fair evaluation of the bid. Addendums in order, along with a summary of exception as a separate attachment, should be with Bidder's Evaluation Report. FAILURE TO SUBMIT THIS REPORT, COMPLETE IN ITS ENTIRETY, MAY SUBJECT THE BIDDER TO DISQUALIFICATION.

Reference Requisition No.: 7011EC05

Bidder's Name: Uniontown Industrial Equipment Co Inc.

Address: 2266 University Drive Lemont Furnace PA 15456

Telephone Number: (724) 437-1578

Years Bidder has been registered to do business with the State of West Virginia: 13 YRS.

Years Company has been an authorized dealer for proposed unit: 9 YRS.

X3.2 Have you complied with all mandatory specifications?  YES  NO

X4.2 DELIVERY:

X4.2.1 Delivery date of completed representative unit: 45 Calendar Days After  
Receipt of Purchase Agreement

X4.2.2 Delivery date of balance of completed units: 120 Calendar Days After Receipt of  
Purchase Agreement

NOTE: Vendor should type Bidder's Evaluation Report

The "Bidder's Evaluation Report" is available for download on Purchasing's Web site at  
[www.state.wv.us/admin/purchase](http://www.state.wv.us/admin/purchase)

X5.0 AWARD CRITERIA;

X5.1 Price per unit:

\$28,873.00 per unit

X6.0 SPECIFICATIONS - GENERAL

X6.1 Manufacturer, model, series, and date of manufacture of proposed unit:

Terex TV1200

Is descriptive literature, fully describing proposed unit attached to your bid?  YES  NO

If not, why? \_\_\_\_\_

X6.2 Will the required number of service manuals, and complete parts list be delivered to the Equipment Division at Buckhannon upon completion of delivery of total units?

YES  NO

Will the required Equipment Preventive Maintenance Form (Section X6.2 of Bidders Evaluation Report) be provided upon inspection of the pilot unit?  YES  NO

X6.2  
2-10-00

**EQUIPMENT PREVENTATIVE MAINTENANCE QUESTIONNAIRE**

THIS FORM MUST BE COMPLETED IN ITS ENTIRETY BY SUCCESSFUL BIDDER OR MANUFACTURER'S TECHNICAL REPRESENTATIVE PRIOR TO DELIVERY OF PILOT MODEL TO THE WVDOH.

DESCRIPTION: \_\_\_\_\_ MAKE: \_\_\_\_\_

MODEL: \_\_\_\_\_ YEAR: \_\_\_\_\_ PURCHASE AMOUNT: \_\_\_\_\_

ENGINE: MAKE: \_\_\_\_\_ MODEL: \_\_\_\_\_ FUEL TYPE: \_\_\_\_\_

HORSEPOWER: \_\_\_\_\_ CYLINDER: \_\_\_\_\_ ENGINE SERIAL: \_\_\_\_\_

COOLING SYSTEM CAPACITY: \_\_\_\_\_

BELTS: DESCRIPTION: \_\_\_\_\_ PART NUMBERS: \_\_\_\_\_

\_\_\_\_\_  
\_\_\_\_\_

GVW: \_\_\_\_\_ AXLE CAPACITY: FRONT: \_\_\_\_\_ REAR: \_\_\_\_\_

TIRES: FRONT MAKE & SIZE: \_\_\_\_\_

REAR MAKE & SIZE: \_\_\_\_\_

DIMENSIONS OF UNIT: LENGTH: \_\_\_\_\_ WIDTH: \_\_\_\_\_ LENGTH: \_\_\_\_\_

VENDOR CONTACT PERSON: \_\_\_\_\_ PHONE: \_\_\_\_\_

**PARTS:**

BATTERY MAKE: \_\_\_\_\_ MODEL: \_\_\_\_\_ CCA: \_\_\_\_\_

TOP OR SIDE POST: \_\_\_\_\_ DIMENSIONS: LENGTH \_\_\_\_\_ WIDTH \_\_\_\_\_ HEIGHT \_\_\_\_\_

SPARK PLUGS OR FUEL INJECTORS MAKE: \_\_\_\_\_ PART # \_\_\_\_\_

FUEL PUMP OR INJECTION PUMP MAKE: \_\_\_\_\_ MODEL: \_\_\_\_\_

ALTERNATOR MAKE: \_\_\_\_\_ PART #: \_\_\_\_\_

STARTER MAKE: \_\_\_\_\_ PART #: \_\_\_\_\_

TURBO CHARGER MAKE: \_\_\_\_\_ PART #: \_\_\_\_\_

TRANS. MAKE: \_\_\_\_\_ MODEL: \_\_\_\_\_ AUTO/MANUAL: \_\_\_\_\_

HYDRAULIC PUMP MAKE: \_\_\_\_\_ MODEL: \_\_\_\_\_

FILTERS	MAKE	PART NO.	LUBRICANT	MANUFACTURER TYPE
OIL	_____	_____	ENGINE	_____
AIR INNER	_____	_____	TRANSMISSION	_____
AIR OUTER	_____	_____	POWER STEERING	_____
FUEL PRIMARY	_____	_____	HYDRAULIC	_____
FUEL SECONDARY	_____	_____	DIFFERENTIALS	_____
COOLANT	_____	_____	BRAKE FLUID	_____
HYDRAULIC	_____	_____	COOLANT	_____
OTHER	_____	_____	OTHER	_____

## X6.3 TRAINING:

Will training seminar be conducted on Preventive Maintenance, Operator and Mechanic Training  
 YES  NO

Will you conduct training with each purchase order against this open end contract?  
 YES  NO

Will training be conducted within 2 working days from the delivery of the pilot unit on the individual purchase order?  
 YES  NO

If NO, explain time frame 2 weeks

Will an Operator's Manual be furnished directly to Training Academy prior to the delivery of the pilot?  
 YES  NO

X6.4 If you are the successful vendor, will you furnish all training aids, i.e., videos, projectors, required in conducting the training?  
 YES  NO

X6.4.1 Will all manuals, booklets, etc. explaining preventive maintenance, operator procedures, and service schedule be delivered with each unit?  
 YES  NO  
 If NO, explain \_\_\_\_\_

## X6.5 WARRANTY AND SERVICE POLICY

Will the warranty and service you provide comply with all areas as stated in Section 6.5 of specifications  
 YES  NO

Is warranty literature attached?  YES  NO

Is a minimum two (2) year bumper to bumper basic parts and labor warranty excluding abuse and normal wear items included?  
 YES  NO

Describe:

---



---



## X6.6 EVALUATION COMMITTEE REQUIREMENTS

Is all component specifications, product literature, component models provided for Evaluation Committee bid determination?  YES  NO

**X6.7 Will all parts, equipment, accessories, material, design and performance characteristics not specified herein, but which are necessary to provide a complete unit, be furnished with the unit and conform in strength, quality of material, and quality of workmanship to those which are advertised and provided to the market in general by the unit industry?**

YES  NO

**X6.7.1 Are all parts and accessories adequate and regularly supplied as standard to be included except those which may be duplications of specifications herein, and except these by specification are not to be furnished?**

YES  NO

**X6.7.2 Are all standard safety features that are required by Federal and State statutes of law included?**

YES  NO

## X7.0 SPECIFICATIONS OF THE QUOTED UNIT

The bidder should complete the following schedule in order for the Division to compare the actual bid unit to the specifications. Should the bidder except a requirement, then such exception may be only on the basis that such feature is not offered by the manufacturer. The Division will have the sole discretion as to whether the bidder's substitution meets the requirements of the specifications.

Manufacturer: Terex Model: TV1200

**X7.1 Are roller(s) equipped with ROPS and FOPS canopy?**  YES  NO

**X7.2 Is engine manufacturer's water/air cooled diesel powered**  YES  NO

**HP: 33 and has sufficient torque to operate machine and hydraulic system at maximum efficiency**  YES  NO

**X7.3 Is steering of hydraulic, full power, articulated design?**  YES  NO

**X7.4 Is unit a low profile design?**  YES  NO

**X7.5 Unit weight: 6,447 pounds**

**X7.6 Wheel base: 65.94 inches**

**X7.7 Does unit have dual drum drive with hydrostatic propulsion?**  YES  NO

X7.8 Is unit equipped with manufacturer's vandalism package?  YES  NO

X7.9 Unit has travel 6.2 MPH to 6.2 MPH forward and reverse

X7.10 Engine:

X7.10.1 Is manufacturer heaviest duty dual fuel filtering system offered?  YES  NO

X7.10.2 Has full pressure lubrication with oil filter and oil by pass system?  YES  NO

X7.10.3 Is governor manufacturer's standard with key shut off, wire sealed by manufacturer?  
 YES  NO

X7.10.4 Is cooling system filled with permanent type Dex-Cool extended life (or equal) to a freeze point of -34° if unit is water cooled  YES  NO

X7.11 Brakes:

X7.11.1 Is service brake through hydrostatic propulsion system  YES  NO

X7.11.2 Is parking brake spring-applied, hydraulically released on each drum drive?  
 YES  NO

X7.12 Drums:

X7.12.1 Are drums manufacturers heavy duty design  YES  NO

X7.12.2 Drum width: 47.24 inches

X7.12.3 Drum diameter: 27.5 inches

X7.12.4 Are wiper bars mounted front and rear of each drum?  YES  NO

X7.12.5 Are wiper bars spring loaded, self adjusting  YES  NO

X7.12.6 Do wiper bars have replaceable rubber/neoprene drum cleaners?  YES  NO

X7.12.7 Are front and rear drums of vibratory compaction type?  YES  NO

X7.12.8 Are vibrating parts isolated from rest of roller?  YES  NO

X7.12.9 Are vibrating system isolators replaceable?  YES  NO

X7.12.10 Will unit be equipped with automatic vibration switch?  YES  NO

X7.13 Electrical:

X7.13.1 Does electrical system have manufacturer's heavy duty 12 volt D.C. negative ground?  
 YES  NO



- X7.13.2 Is manufacturers recommended heavy duty maintenance free battery provided?  YES  NO
- X7.13.3 Battery CCA: 830
- X7.13.4 Alternator: 55 AMP with internal regulator
- X7.14 Will gauges be illuminated and equipped with visual or audible warning that will advise operator when manufacturer recommended safe operating ranges are exceeded?  YES  NO
- X7.14.1 Is unit provided with hour meter operable from engine operation (not key switch)?  YES  NO
- X7.14.2 Is ignition switch water sealed?  YES  NO
- X7.14.3 Fuel gauge?  YES  NO
- X7.14.4 Volt/amp meter gauge or light  YES  NO
- X7.14.5 Oil pressure gauge or light  YES  NO
- X7.14.6 Engine temperature gauge or light  YES  NO
- X7.14.7 Does operators station have manufacturer's fully adjustable isolation mounted seat with seat belt  YES  NO
- X7.14.8 Is OSHA approved back-up alarm provided and installed by manufacturer  YES  NO
- X7.14.9 Does unit have a parking brake "on" indicator?  YES  NO
- \*\*When machine in neutral parking brake is applied by hydraulics.
- X7.14.10 Is a neutral start safety switch provided  YES  NO
- X7.15 Water System:
- X7.15.1 Tank capacity: 11.6 gallons
- X7.15.2 Is water system pressurized?  YES  NO
- X7.15.3 Is water flow variable?  YES  NO
- X7.15.4 Water filter(s) provided in system?  YES  NO
- X7.15.5 Screened back nozzle type sprayers on drums  YES  NO
- X7.15.6 Is empty water tank indicator provided?  YES  NO

\*\*Visual Ease Indicator\*\*

- X7.15.7 Is water pump capable of "Run Dry" situation without damage to pump or components?  
 YES  NO
- X7.15.8 Is water tank and complete water system constructed of rust proof materials  
 YES  NO
- X7.15.9 Does water tank have drain plug?  
 YES  NO
- X7.16 Lighting:
- X7.16.1 Is unit equipped with flashers visible from front and rear of roller  YES  NO
- X7.16.2 Are work lights installed front and rear of roller  YES  NO  
Are there 2 in front and two in rear  YES  NO
- X7.16.3 Is a low profile high intensity dual flash strobe light mounted on top of cab/canopy  
 YES  NO  
Manufacturer: Aero Flash Model: 420
- X7.17 Will unit be delivered to WVDOH with all manufacturers recommended safety related decals and safety features intact  
 YES  NO
- X7.18 Is one (1) complete set of replacement filters provided with each unit upon delivery?  
 YES  NO
- X7.19 Paint:
- X7.19.1 Is manufacturer's recommended paint preparation and color provided?  
 YES  NO
- X7.20 Does vendor certify that roller offered meets or exceed the "OSHA of 1970" or changes that are in effect at time of manufacturer of unit?  
 YES  NO
- X7.21 Does unit conform to the advertising guidelines?  
 YES  NO
- X7.22 Preventive Maintenance and Operators Orientation/Training:
- X7.22.1 Have you attached a copy of proposed training program along with schedule of course. Will you furnish all training aids?  
 YES  NO

# **Uniontown Industrial Equipment Co., Inc.**

2266 University Drive • Lemont Furnace, PA 15456  
Telephone (724) 437-1578 Fax (724) 437-2098

## **“EXCEPTIONS TO SPECIFICATIONS”**

**RFQ # 7001EC05**

**7.14.9 When machine in neutral parking brake is applied by hydraulics**

**7.15.6 Visual Ease Indicator**

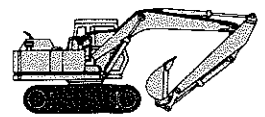
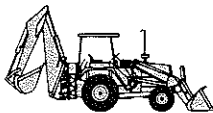



State of West Virginia  
 Department of Administration  
 Purchasing Division  
 2019 Washington Street East  
 Post Office Box 50130  
 Charleston, WV 25305-0130

# Request for Quotation

RFQ NUMBER
7011EC05

PAGE
1

ADDRESS CORRESPONDENCE TO ATTENTION OF
BUYER 33 304-558-2402

\*709015804      724-437-1578  
 UNIONTOWN INDUSTRIAL EQUIP CO  
 2266 UNIVERSITY DR  
 ELEMONT FURNACE PA 15478

DIVISION OF HIGHWAYS  
 EQUIPMENT DIVISION  
 ROUTE 33  
 BRUSHY FORK ROAD  
 BUCKHANNON, WV  
 26201      304-472-1750

DATE PRINTED	TERMS OF SALE	SHIP VIA	F.O.B.	FREIGHT TERMS
11/10/2010				

BID OPENING DATE: 11/17/2010      BID OPENING TIME 01:30PM

LINE	QUANTITY	UOP	CAT NO.	ITEM NUMBER	UNIT PRICE	AMOUNT
ADDENDUM NO. 1						
THIS ADDENDUM IS ISSUED TO:						
1.) ADDRESS CHANGES AND CONCERNS TO SPECIFICATIONS AS DISCUSSED AND AGREED UPON DURING MANDATORY PRE-BID MEETING, SEE ATTACHED.						
2.) TO EXTEND BID OPENING DATE FROM 11/10/2010 TO 11/17/2010.						
3.) PROVIDE A COPY OF THE MANDATORY PRE-BID ATTENDEE LIST.						
NO OTHER CHANGES						
0001	1	EA	760-75		\$28,873.00	\$28,873.00
DOUBLE DRUM VIBRATORY ROLLER/COMPACTOR						
***** THIS IS THE END OF RFQ 7011EC05 ***** TOTAL:						\$28,873.00

SEE REVERSE SIDE FOR TERMS AND CONDITIONS		
SIGNATURE	TELEPHONE	DATE
<i>Michael W. ...</i>	(724) 437-1578	11/15/10
TITLE	FEIN	ADDRESS CHANGES TO BE NOTED ABOVE
V. PRESIDENT	25-1389795	

WHEN RESPONDING TO RFQ, INSERT NAME AND ADDRESS IN SPACE ABOVE LABELED 'VENDOR'

PREBID ADDENDUM  
70-11-EC05

DOUBLE DRUM VIBRATORY ROLLER/COMPACTOR

CHANGES TO SPECIFICATIONS:

LEAVE AS WRITTEN:

**7.1 Roller(s) shall be equipped with ROPS and FOPS canopy.**

LEAVE AS WRITTEN:

**7.15.6 Empty water tank indicator to be provided.**

LEAVE AS WRITTEN:

**7.15.7 Water pump shall be capable of "Run Dry" situation without damage to pump or Components**

FROM:

**7.16.3 Low profile high intensity dual flash strobe light shall be mounted on top of cab/canopy. Aero Flash Model number M420 or equivalent. (Amber in color)**

TO:

**7.16.3 Class 1 LED beacon shall be mounted on top of cab/canopy.**

PREBID ADDENDUM  
70-11-EC05

DOUBLE DRUM VIBRATORY ROLLER/COMPACTOR

CHANGES TO BIDDER'S EVALUATION REPORT:

NO CHANGE REQUIRED:

X7.1 Are roller(s) equipped with ROPS and FOPS canopy?  YES  NO

NO CHANGE REQUIRED:

X7.15.6 Is empty water tank indicator provided?  YES  NO

\*\*Visual Ease Indicator

NO CHANGE REQUIRED:

X7.15.7 Is water pump capable of "Run Dry" situation without damage to pump or components?  YES  NO

FROM:

X7.16.3 Is a low profile high intensity dual flash strobe light mounted on top of cab/canopy  YES  NO

Manufacturer: ECCO Model: 7160

TO:

X7.16.3 Is a Class 1 LED beacon mounted on top of cab/canopy?  YES  NO

Manufacturer: ECCO Model: 7160

Request for Quotation Number: DOH-7011EC05

Date: 10/28/2010 at 10:00 am

**Double Drum Vibratory Roller/Compactor**

Project Description:

PLEASE PRINT LEGIBLY. THIS INFORMATION IS ESSENTIAL TO CONTACT THE ATTENDEES IN A TIMELY MANNER. FAILURE TO DO SO MAY RESULT IN DELAYS IN YOUR COMPANY GETTING IMPORTANT BID INFORMATION.

Firm Name:	WV State Purchasing Division
Firm Address:	2019 Washington St., East Charleston, WV 25305
Representative Attending:	Krista Ferrell, Buyer Supervisor
Phone Number:	304.558.2596
Fax Number:	304.558.4115
Email Address:	krista.s.ferrell@wv.gov

Firm Name:	WEST VIRGINIA TRACTOR
Firm Address:	P.O. BOX 473 CHARLESTON WV 25322
Representative Attending:	GARY ORADY
Phone Number:	304-346-5301
Fax Number:	304-346-5305
Email Address:	WORADY@WVSTL.COM

Firm Name:	WVDOA
Firm Address:	
Representative Attending:	Kevin Riley
Phone Number:	
Fax Number:	
Email Address:	

Firm Name:	RISH EQUIPMENT COMPANY
Firm Address:	P.O. BOX 906 BRIDGEPORT, WV 26230
Representative Attending:	ANTONIO B. SELARIO
Phone Number:	304-842-3511 EXT 6514
Fax Number:	304-842-1616
Email Address:	ASELARIO@RISH.COM

Firm Name:	STATE EQUIPMENT, INC
Firm Address:	P.O. Box 3939 CHARLESTON, WV 25329
Representative Attending:	STEWART M. ROWAN, JR
Phone Number:	(304) 776-4405
Fax Number:	(304) 776-4409
Email Address:	eddie@stateequipment.com

Firm Name:	C.I. WALKER MACHINERY CO
Firm Address:	P.O. Box 2427 CHARLESTON, WV 25329
Representative Attending:	MATTHEW E. CONNER
Phone Number:	(304) 543-5406
Fax Number:	(304) 759-6404
Email Address:	MConner@ciwalker-mch.com

PRE-BID CONFERENCE  
SIGN IN SHEET

Request for Quotation Number: DOH-7011EC05

Date: 10/28/2010 at 10:00 am

Project Description: Double Drum Vibratory Roller/Compactor

PLEASE PRINT LEGIBLY. THIS INFORMATION IS ESSENTIAL TO CONTACT THE ATTENDEES IN A TIMELY MANNER. FAILURE TO DO SO MAY RESULT IN DELAYS IN YOUR COMPANY GETTING IMPORTANT BID INFORMATION.

Firm Name:	<u>Leslie Equipment Co</u>
Firm Address:	<u>284 VANKIRK DRIVE FAIRMONT, WV 26554</u>
Representative Attending:	<u>Timothy C. Wagner</u>
Phone Number:	<u>304-534-5454</u>
Fax Number:	<u>304-534-5888</u>
Email Address:	<u>wagner.tim@lecl.com</u>

Firm Name:	<u>RUDD EQUIPMENT CO.</u>
Firm Address:	<u>BUNCHER COMMERCE PARK BLDG 1 AVE, A LEEDSDALE PA 15056</u>
Representative Attending:	<u>BRIAN REED</u>
Phone Number:	<u>(304) 319-1495</u>
Fax Number:	<u>(412) 741-6236</u>
Email Address:	<u>BREED@RUDD-EQUIPMENT.COM</u>

Firm Name:	<u>ROPE INC.</u>
Firm Address:	<u>5522 ELK RIVER ROAD EUKLEIN, WV 25071</u>
Representative Attending:	<u>JOE HOOVER</u>
Phone Number:	<u>304-548-6701</u>
Fax Number:	<u>304-548-7186</u>
Email Address:	<u>joe@ropeincorporated.com</u>

Firm Name:	<u>Angie Maorman</u>
Firm Address:	<u>WUNDAH</u>
Representative Attending:	
Phone Number:	
Fax Number:	
Email Address:	

Firm Name:	<u>Uniontown Ind. EP. (D) Inc</u>
Firm Address:	<u>2266 University Drive</u>
Representative Attending:	<u>Nike Clopper</u>
Phone Number:	<u>800-229-5948 / 724-432-1570</u>
Fax Number:	<u>724-437-2698</u>
Email Address:	<u>niclopper@uirc.com</u>

Firm Name:	<u>Marcia Reed</u>
Firm Address:	<u>DOH</u>
Representative Attending:	
Phone Number:	
Fax Number:	
Email Address:	



**SIGN IN SHEET**

Request for Quotation Number:

**DOH-7011EC05**

Date:

**10/28/2010 at 10:00 am**

3

**Double Drum Vibratory Roller/Compactor**

Project Description:

**PLEASE PRINT LEGIBLY. THIS INFORMATION IS ESSENTIAL TO CONTACT THE ATTENDEES IN A TIMELY MANNER. FAILURE TO DO SO MAY RESULT IN DELAYS IN YOUR COMPANY GETTING IMPORTANT BID INFORMATION.**

Firm Name:	<i>Karen Cochran</i>
Firm Address:	<i>DOTT</i>
Representative Attending:	
Phone Number:	
Fax Number:	
Email Address:	

Firm Name:	
Firm Address:	
Representative Attending:	
Phone Number:	
Fax Number:	
Email Address:	

Firm Name:	<i>WV Purchasing Division</i>
Firm Address:	
Representative Attending:	<i>Shari Stone</i>
Phone Number:	
Fax Number:	
Email Address:	

Firm Name:	
Firm Address:	
Representative Attending:	
Phone Number:	
Fax Number:	
Email Address:	

Firm Name:	
Firm Address:	
Representative Attending:	
Phone Number:	
Fax Number:	
Email Address:	

Firm Name:	
Firm Address:	
Representative Attending:	
Phone Number:	
Fax Number:	
Email Address:	

# COMPACTION ROLLER



## Specifications

Operating Weight	5664 / 6447 lbs
Net Engine Power	33 hp
Static Linear Load	71.9 / 68.2 lbs/in
Centrifugal Force	5167 / 6740 lbs

## Features

- Powerful and reliable water cooled engines.
- Superb service access and easy to service components.
- "Rental Tough" high quality heavy duty design.
- Heavy duty vibration system with high centrifugal force, frequency and static liner load reduces the number of passes required.
- Unique side control arm for increased operator leg room and comfort.
- Unique 6-in-1 control lever for simple and easy operation of all functions.
- Lockable instrumental panel, water tank filler flap and hood to reduce theft and vandalism.
- Simple lever selection of twin drum vibration or rear drum vibration.

**WORKS FOR YOU.™**

# SPECIFICATIONS

## Performance

	TV1000	TV1200
Operating Weight	5664 lbs (2570 kg)	6447 lbs (2925 kg)
Basic Weight	5257 lbs (2385 kg)	6040 lbs (2740 kg)
Static Linear Load	71.9 lbs/in (12.85 kg/cm)	68.2 lbs/in (12.18 kg/cm)
Frequency (Hz) VPM	3360 (56 Hz)	3360 (56 Hz)
Amplitude	.022 in (0.6 mm)	.022 in (0.6 mm)
Gradeability (% - vibration on)	30%	30%
Gradeability (% - vibration off)	40%	40%
Centrifugal Force (low / high)	3819/5167 lbs (17/23 kN)	4943/6740 lbs (22/30 kN)
Drum Thickness	.39 in (10 mm)	.51 in (13 mm)

## Engine

	TV1000	TV1200
Engine	Kubota D1703-M 3-cylinder, diesel engine	
Cooling System	Water	
Power	33 hp (24.5 kW) at 2,500 rpm	
Drive	Dual radial piston drive motors	
Braking System - Service	Hydrostatic drive provides dynamic braking	
Braking System - Parking	Spring applied brakes	

## Electrical System

	TV1000	TV1200
Battery	830 CCA	
Alternator	55 Amp	

## Transmission

	TV1000	TV1200
	Hydrostatic drive. Forward and reverse selected from joystick. Infinitely variable speed control forward and reverse. 0 - 6.2 mph (0 - 10 km/hr)	



## Steering

	TV1000	TV1200
Type	Heavy-duty articulated steering	
Frame Articulation	30°	
Frame Oscillation	15°	
Turning Radius - Inside	103 in (2,625 mm)	99 in (2,525 mm)

## Fluid Capacities

	TV1000	TV1200
Fuel Tank	11.6 gal (44 L)	
Hydraulic System (includes tank)	11.6 gal (44 L)	
Water Tank	47.5 gal (180 L)	

## Operator's Area

	TV1000	TV1200
	Open operator's seat with functional design, excellent all-round visibility and user-friendly operator controls.	
	Operator's suspension seat with hydraulic cushioning and lap belt; weight, height and longitudinally adjustable.	

# DIMENSIONS

# TV1000 / TV1200

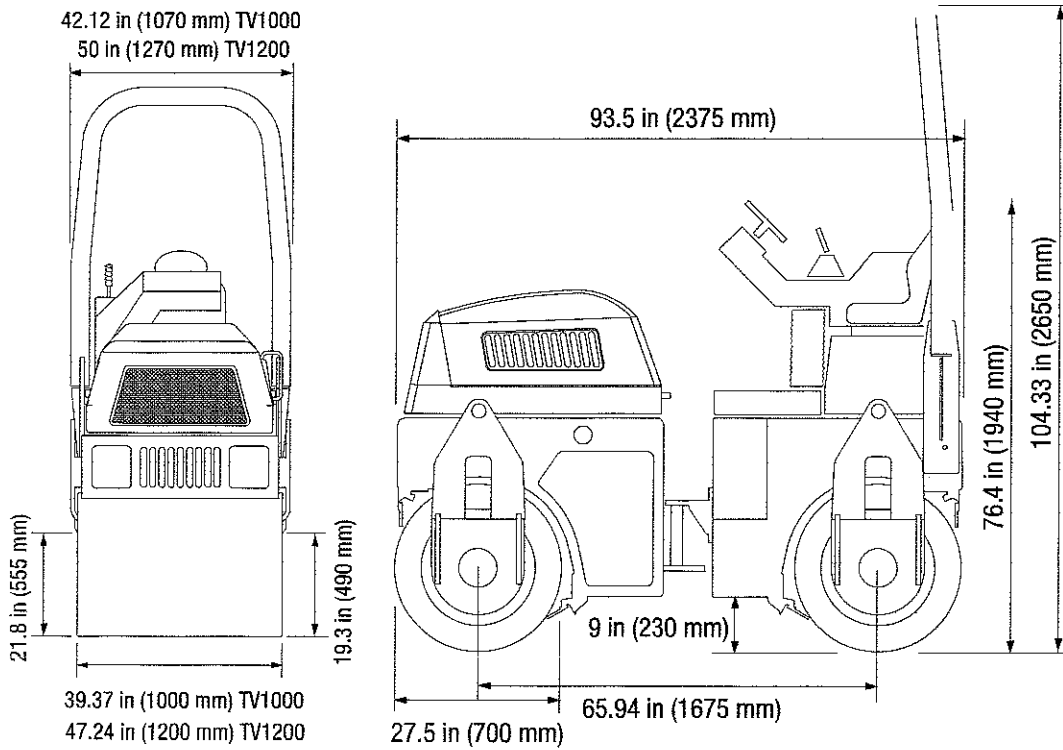

## Dimensions

	TV1000	TV1200
Total Width	42.12 in (1,070 mm)	50 in (1,270 mm)
Total Length	93.5 in (2,375 mm)	
Total Height	104.33 in (2,650 mm)	

## Standard Equipment

Vandal Protection Package	Back-up alarm
2 scraper bars per drum	Hydraulic test points
Tow valve	12 volt battery disconnect
Pressure and gravity water	ROPS
Electrical diagnostics system (LED lights)	

**WORKS FOR YOU.**

**terex.com**

Effective Date: May 2010. Product specifications and prices are subject to change without notice or obligation. The photographs and/or drawings in this document are for illustrative purposes only. Refer to the appropriate Operator's Manual for instructions on the proper use of this equipment. Failure to follow the appropriate Operator's Manual when using our equipment or to otherwise act irresponsibly may result in serious injury or death. The only warranty applicable to our equipment is the standard written warranty applicable to the particular product and sale and Terex makes no other warranty, express or implied. Products and services listed may be trademarks, service marks, or trade names of Terex Corporation and/or its subsidiaries in the USA and other countries. All rights are reserved. Terex is a registered trademark of Terex Corporation in the USA and many other countries. © 2010 Terex Corporation.

8800 Rostin Road, Southaven, MS 38671 USA  
1.888.90.TEREX (83739)



**TEREX®**

**WORKS FOR YOU™**

TV1003/TV1200 0310 PH 103039

Rev. 09/08

State of West Virginia  
**VENDOR PREFERENCE CERTIFICATE**

Certification and application\* is hereby made for Preference in accordance with *West Virginia Code*, §5A-3-37. (Does not apply to construction contracts). *West Virginia Code*, §5A-3-37, provides an opportunity for qualifying vendors to request (at the time of bid) preference for their residency status. Such preference is an evaluation method only and will be applied only to the cost bid in accordance with the *West Virginia Code*. This certificate for application is to be used to request such preference. The Purchasing Division will make the determination of the Resident Vendor Preference, if applicable.

1. **Application is made for 2.5% resident vendor preference for the reason checked:**

- Bidder is an individual resident vendor and has resided continuously in West Virginia for four (4) years immediately preceding the date of this certification; or,
- Bidder is a partnership, association or corporation resident vendor and has maintained its headquarters or principal place of business continuously in West Virginia for four (4) years immediately preceding the date of this certification; or 80% of the ownership interest of Bidder is held by another individual, partnership, association or corporation resident vendor who has maintained its headquarters or principal place of business continuously in West Virginia for four (4) years immediately preceding the date of this certification; or,
- Bidder is a nonresident vendor which has an affiliate or subsidiary which employs a minimum of one hundred state residents and which has maintained its headquarters or principal place of business within West Virginia continuously for the four (4) years immediately preceding the date of this certification; or,

2. **Application is made for 2.5% resident vendor preference for the reason checked:**

- Bidder is a resident vendor who certifies that, during the life of the contract, on average at least 75% of the employees working on the project being bid are residents of West Virginia who have resided in the state continuously for the two years immediately preceding submission of this bid; or,

3. **Application is made for 2.5% resident vendor preference for the reason checked:**

- Bidder is a nonresident vendor employing a minimum of one hundred state residents or is a nonresident vendor with an affiliate or subsidiary which maintains its headquarters or principal place of business within West Virginia employing a minimum of one hundred state residents who certifies that, during the life of the contract, on average at least 75% of the employees or Bidder's affiliate's or subsidiary's employees are residents of West Virginia who have resided in the state continuously for the two years immediately preceding submission of this bid; or,

4. **Application is made for 5% resident vendor preference for the reason checked:**

- Bidder meets either the requirement of both subdivisions (1) and (2) or subdivision (1) and (3) as stated above; or,

5. **Application is made for 3.5% resident vendor preference who is a veteran for the reason checked:**

- Bidder is an individual resident vendor who is a veteran of the United States armed forces, the reserves or the National Guard and has resided in West Virginia continuously for the four years immediately preceding the date on which the bid is submitted; or,

6. **Application is made for 3.5% resident vendor preference who is a veteran for the reason checked:**

- Bidder is a resident vendor who is a veteran of the United States armed forces, the reserves or the National Guard, if, for purposes of producing or distributing the commodities or completing the project which is the subject of the vendor's bid and continuously over the entire term of the project, on average at least seventy-five percent of the vendor's employees are residents of West Virginia who have resided in the state continuously for the two immediately preceding years.

Bidder understands if the Secretary of Revenue determines that a Bidder receiving preference has failed to continue to meet the requirements for such preference, the Secretary may order the Director of Purchasing to: (a) reject the bid; or (b) assess a penalty against such Bidder in an amount not to exceed 5% of the bid amount and that such penalty will be paid to the contracting agency or deducted from any unpaid balance on the contract or purchase order.

By submission of this certificate, Bidder agrees to disclose any reasonably requested information to the Purchasing Division and authorizes the Department of Revenue to disclose to the Director of Purchasing appropriate information verifying that Bidder has paid the required business taxes, provided that such information does not contain the amounts of taxes paid nor any other information deemed by the Tax Commissioner to be confidential.

Under penalty of law for false swearing (*West Virginia Code*, §61-5-3), Bidder hereby certifies that this certificate is true and accurate in all respects; and that if a contract is issued to Bidder and if anything contained within this certificate changes during the term of the contract, Bidder will notify the Purchasing Division in writing immediately.

Bidder: Uniontown Industrial Equip.

Signed: 

Date: 11/08/10

Title: V. President

\*Check any combination of preference consideration(s) indicated above, which you are entitled to receive.

RFQ No. 7011EC05

STATE OF WEST VIRGINIA  
Purchasing Division

**PURCHASING AFFIDAVIT**

West Virginia Code §5A-3-10a states: No contract or renewal of any contract may be awarded by the state or any of its political subdivisions to any vendor or prospective vendor when the vendor or prospective vendor or a related party to the vendor or prospective vendor is a debtor and the debt owned is an amount greater than one thousand dollars in the aggregate

**DEFINITIONS:**

"Debt" means any assessment, premium, penalty, fine, tax or other amount of money owed to the state or any of its political subdivisions because of a judgment, fine, permit violation, license assessment, defaulted workers' compensation premium, penalty or other assessment presently delinquent or due and required to be paid to the state or any of its political subdivisions, including any interest or additional penalties accrued thereon.

"Debtor" means any individual, corporation, partnership, association, Limited Liability Company or any other form or business association owing a debt to the state or any of its political subdivisions. "Political subdivision" means any county commission; municipality; county board of education; any instrumentality established by a county or municipality; any separate corporation or instrumentality established by one or more counties or municipalities, as permitted by law; or any public body charged by law with the performance of a government function or whose jurisdiction is coextensive with one or more counties or municipalities. "Related party" means a party, whether an individual, corporation, partnership, association, limited liability company or any other form or business association or other entity whatsoever, related to any vendor by blood, marriage, ownership or contract through which the party has a relationship of ownership or other interest with the vendor so that the party will actually or by effect receive or control a portion of the benefit, profit or other consideration from performance of a vendor contract with the party receiving an amount that meets or exceed five percent of the total contract amount.

**EXCEPTION:** The prohibition of this section does not apply where a vendor has contested any tax administered pursuant to chapter eleven of this code, workers' compensation premium, permit fee or environmental fee or assessment and the matter has not become final or where the vendor has entered into a payment plan or agreement and the vendor is not in default of any of the provisions of such plan or agreement.

Under penalty of law for false swearing (*West Virginia Code* §61-5-3), it is hereby certified that the vendor affirms and acknowledges the information in this affidavit and is in compliance with the requirements as stated.

**WITNESS THE FOLLOWING SIGNATURE**

Vendor's Name: Uniontown Industrial Equipment Co Inc

Authorized Signature: Michael W. [Signature] Date: 11/15/10

State of Pennsylvania

County of Fayette, to-wit:

Taken, subscribed, and sworn to before me this 15 day of Nov. 2010.

My Commission expires June 29, 2011.

AFFIX SEAL HERE

NOTARY PUBLIC

Tammy L. Mauk [Signature]

