



State of West Virginia
 Department of Administration
 Purchasing Division
 2019 Washington Street East
 Post Office Box 50130
 Charleston, WV 25305-0130

Request for Quotation

RFQ NUMBER
7010EC010

PAGE
1

ADDRESS CORRESPONDENCE TO ATTENTION OF
MICHAEL AUSTIN 304-558-2402

RFQ COPY

TYPE NAME/ADDRESS HERE

BAKER TRUCK EQUIPMENT
 P.O. BOX 482
 HURRICANE, WV 25526

DIVISION OF HIGHWAYS
 EQUIPMENT DIVISION
 ROUTE 33
 BRUSHY FORK ROAD
 BUCKHANNON, WV
 26201 304-472-1750

DATE PRINTED	TERMS OF SALE	SHIP VIA	F.O.B.	FREIGHT TERMS
05/18/2010	NET 10 DAYS	MOTOR FREIGHT	BUCKHANNON, WV	PREPAID
BID OPENING DATE: 06/30/2010		BID OPENING TIME 01:30PM		

LINE	QUANTITY	UOP	CAT NO.	ITEM NUMBER	UNIT PRICE	AMOUNT
0001	1	EA		765-59	10 FT. - \$6,415.00 11 FT. - \$6,953.00	\$6,415.00 EACH \$6,953.00 EACH
PROVIDE POWER REVERSIBLE SNOWPLOW OPEN END CONTRACT TO PROVIDE 10 FOOT AND 11 FOOT HENDERSON OR EQUAL POWER REVERSIBLE SNOWPLOW. PER THE ATTACHED. THE MODEL/BRAND/SPECIFICATIONS NAMED HEREIN ESTABLISH THE ACCEPTABLE LEVEL OF QUALITY ONLY AND ARE NOT INTENDED TO REFLECT A PREFERENCE OR FAVOR ANY PARTICULAR BRAND OR VENDOR. VENDORS WHO ARE BIDDING ALTERNATES SHOULD SO STATE AND INCLUDE PERTINENT LITERATURE AND SPECIFICATIONS. FAILURE TO PROVIDE INFORMATION FOR ANY ALTERNATES MAY BE GROUNDS FOR REJECTION OF THE BID. THE STATE RESERVES THE RIGHT TO WAIVE MINOR IRREGULARITIES IN BIDS OR SPECIFICATIONS IN ACCORDANCE WITH SECTION 148-1-4(F) OF THE WEST VIRGINIA LEGISLATIVE RULES AND REGULATIONS. MANDATORY PRE-BID A MANDATORY PRE-BID WILL BE HELD ON THURSDAY, 06/10/10 AT 10 AM IN BUILDING 15, CAPITAL COMPLEX, CHAS, WV. ALL INTERESTED PARTIES ARE REQUIRED TO ATTEND THIS MEETING FAILURE TO ATTEND THE MANDATORY PRE-BID SHALL RESULT IN DISQUALIFICATION OF THE BID. NO ONE PERSON MAY REPRESENT MORE THAN ONE BIDDER. AN ATTENDANCE SHEET WILL BE MADE AVAILABLE FOR ALL POTENTIAL BIDDERS TO COMPLETE. THIS WILL SERVE AS THE						

RECEIVED

2010 JUL 20 AM 11:16

WV PURCHASING DIVISION

SEE REVERSE SIDE FOR TERMS AND CONDITIONS			
SIGNATURE	TELEPHONE	DATE	
<i>Michael Austin</i>	304-722-3814	7/19/2010	
TITLE	ADDRESS CHANGES TO BE NOTED ABOVE		
SALESMAN	55-0711783		

WHEN RESPONDING TO REQ. INSERT NAME AND ADDRESS IN SPACE ABOVE LABELED 'VENDOR'

GENERAL TERMS & CONDITIONS REQUEST FOR QUOTATION (RFQ) AND REQUEST FOR PROPOSAL (RFP)

1. Awards will be made in the best interest of the State of West Virginia.
2. The State may accept or reject in part, or in whole, any bid.
3. Prior to any award, the apparent successful vendor must be properly registered with the Purchasing Division and have paid the required \$125 fee.
4. All services performed or goods delivered under State Purchase Order/Contracts are to be continued for the term of the Purchase Order/Contracts, contingent upon funds being appropriated by the Legislature or otherwise being made available. In the event funds are not appropriated or otherwise available for these services or goods this Purchase Order/Contract becomes void and of no effect after June 30.
5. Payment may only be made after the delivery and acceptance of goods or services.
6. Interest may be paid for late payment in accordance with the *West Virginia Code*.
7. Vendor preference will be granted upon written request in accordance with the *West Virginia Code*.
8. The State of West Virginia is exempt from federal and state taxes and will not pay or reimburse such taxes.
9. The Director of Purchasing may cancel any Purchase Order/Contract upon 30 days written notice to the seller.
10. The laws of the State of West Virginia and the *Legislative Rules* of the Purchasing Division shall govern the purchasing process.
11. Any reference to automatic renewal is hereby deleted. The Contract may be renewed only upon mutual written agreement of the parties.
12. **BANKRUPTCY:** In the event the vendor/contractor files for bankruptcy protection, the State may deem this contract null and void, and terminate such contract without further order.
13. **HIPAA BUSINESS ASSOCIATE ADDENDUM:** The West Virginia State Government HIPAA Business Associate Addendum (BAA), approved by the Attorney General, is available online at www.state.wv.us/admin/purchase/vrc/hipaa.htm and is hereby made part of the agreement. Provided that the Agency meets the definition of a Cover Entity (45 CFR §160.103) and will be disclosing Protected Health Information (45 CFR §160.103) to the vendor.
14. **CONFIDENTIALITY:** The vendor agrees that he or she will not disclose to anyone, directly or indirectly, any such personally identifiable information or other confidential information gained from the agency, unless the individual who is the subject of the information consents to the disclosure in writing or the disclosure is made pursuant to the agency's policies, procedures, and rules. Vendor further agrees to comply with the Confidentiality Policies and Information Security Accountability Requirements, set forth in <http://www.state.wv.us/admin/purchase/privacy/noticeConfidentiality.pdf>.
15. **LICENSING:** Vendors must be licensed and in good standing in accordance with any and all state and local laws and requirements by any state or local agency of West Virginia, including, but not limited to, the West Virginia Secretary of State's Office, the West Virginia Tax Department, and the West Virginia Insurance Commission. The vendor must provide all necessary releases to obtain information to enable the director or spending unit to verify that the vendor is licensed and in good standing with the above entities.
16. **ANTITRUST:** In submitting a bid to any agency for the State of West Virginia, the bidder offers and agrees that if the bid is accepted the bidder will convey, sell, assign or transfer to the State of West Virginia all rights, title and interest in and to all causes of action it may now or hereafter acquire under the antitrust laws of the United States and the State of West Virginia for price fixing and/or unreasonable restraints of trade relating to the particular commodities or services purchased or acquired by the State of West Virginia. Such assignment shall be made and become effective at the time the purchasing agency tenders the initial payment to the bidder.

I certify that this bid is made without prior understanding, agreement, or connection with any corporation, firm, limited liability company, partnership, or person or entity submitting a bid for the same material, supplies, equipment or services and is in all respects fair and without collusion or Fraud. I further certify that I am authorized to sign the certification on behalf of the bidder or this bid.

INSTRUCTIONS TO BIDDERS

1. Use the quotation forms provided by the Purchasing Division. Complete all sections of the quotation form.
2. Items offered must be in compliance with the specifications. Any deviation from the specifications must be clearly indicated by the bidder. Alternates offered by the bidder as **EQUAL** to the specifications must be clearly defined. A bidder offering an alternate should attach complete specifications and literature to the bid. The Purchasing Division may waive minor deviations to specifications.
3. Unit prices shall prevail in case of discrepancy. All quotations are considered F.O.B. destination unless alternate shipping terms are clearly identified in the quotation.
4. All quotations must be delivered by the bidder to the office listed below prior to the date and time of the bid opening. Failure of the bidder to deliver the quotations on time will result in bid disqualifications: Department of Administration, Purchasing Division, 2019 Washington Street East, P.O. Box 50130, Charleston, WV 25305-0130
5. Communication during the solicitation, bid, evaluation or award periods, except through the Purchasing Division, is strictly prohibited (W.Va. C.S.R. §148-1-6.6).



State of West Virginia
 Department of Administration
 Purchasing Division
 2019 Washington Street East
 Post Office Box 50130
 Charleston, WV 25305-0130

Request for Quotation

RFQ NUMBER
7010EC010

PAGE
2

ADDRESS CORRESPONDENCE TO ATTENTION OF:
MICHAEL AUSTIN 304-558-2402

RFQ COPY

TYPE NAME/ADDRESS HERE

BAKER TRUCK EQUIPMENT
 P.O. BOX 482
 HURRICANE, WV 25526

DIVISION OF HIGHWAYS
 EQUIPMENT DIVISION
 ROUTE 33
 BRUSHY FORK ROAD
 BUCKHANNON, WV
 26201 304-472-1750

DATE PRINTED	TERMS OF SALE	SHIP VIA	F.O.B.	FREIGHT TERMS
05/18/2010	NET 10 DAYS	MOTOR FREIGHT	BUCKHANNON, WV	PREPAID
BID OPENING DATE: 06/30/2010		BID OPENING TIME 01:30PM		

LINE	QUANTITY	UOP	CAT NO.	ITEM NUMBER	UNIT PRICE	AMOUNT
<p>OFFICIAL DOCUMENT VERIFYING ATTENDANCE AT THE MANDATORY PRE-BID. FAILURE TO PROVIDE YOUR COMPANY AND REPRESENTATIVE NAME ON THE ATTENDANCE SHEET WILL RESULT IN DISQUALIFICATION OF THE BID. THE STATE WILL NOT ACCEPT ANY OTHER DOCUMENTATION TO VERIFY ATTENDANCE. THE BIDDER IS RESPONSIBLE FOR ENSURING THEY HAVE COMPLETED THE INFORMATION REQUIRED ON THE ATTENDANCE SHEET. THE PURCHASING DIVISION AND THE STATE AGENCY WILL NOT ASSUME ANY RESPONSIBILITY FOR A BIDDER'S FAILURE TO COMPLETE THE PRE-BID ATTENDANCE SHEET. IN ADDITION, WE REQUEST THAT ALL POTENTIAL BIDDERS INCLUDE THEIR E-MAIL ADDRESS AND FAX NUMBER.</p> <p>ALL POTENTIAL BIDDERS ARE REQUESTED TO ARRIVE PRIOR TO THE STARTING TIME FOR THE PRE-BID. BIDDERS WHO ARRIVE LATE, BUT PRIOR TO THE DISMISSAL OF THE TECHNICAL PORTION OF THE PRE-BID WILL BE PERMITTED TO SIGN IN. BIDDERS WHO ARRIVE AFTER CONCLUSION OF THE TECHNICAL PORTION OF THE PRE-BID, BUT DURING ANY SUBSEQUENT PART OF THE PRE-BID WILL NOT BE PERMITTED TO SIGN THE ATTENDANCE SHEET.</p> <p>QUESTIONS: WRITTEN QUESTIONS WILL BE ACCEPTED THROUGH CLOSE OF BUSINESS (5:00 PM EST) ON TUESDAY, 06/01/2010.</p> <p>SEND YOUR QUESTIONS TO: PURCHASING DIVISION ATTENTION MICHAEL AUSTIN 2019 WASHINGTON ST., E., CHARLESTON, WV 25305</p> <p>QUESTIONS MAY BE SENT VIA FAX, E-MAIL, OR REGULAR MAIL. E-MAIL: MICHAEL.D.AUSTIN@WV.GOV FAX: 304-558-4115</p> <p>IT IS THE VENDORS RESPONSIBILITY TO VERIFY THAT THEIR QUESTIONS HAVE BEEN RECEIVED BY CALLING 304-558-2402.</p>						

SEE REVERSE SIDE FOR TERMS AND CONDITIONS

SIGNATURE	TELEPHONE	DATE
<i>Michael Austin</i>	304-722-3814	7/19/2010
TITLE	FEIN	ADDRESS CHANGES TO BE NOTED ABOVE
SALESMAN	55-0711783	

WHEN RESPONDING TO REQ. INSERT NAME AND ADDRESS IN SPACE ABOVE LABELED 'VENDOR'



State of West Virginia
 Department of Administration
 Purchasing Division
 2019 Washington Street East
 Post Office Box 50130
 Charleston, WV 25305-0130

Request for Quotation

RFQ NUMBER
7010EC010

PAGE
3

ADDRESS CORRESPONDENCE TO ATTENTION OF:
MICHAEL AUSTIN
304-558-2402

RFQ COPY
 TYPE NAME/ADDRESS HERE

V
E
N
D
O
R

BAKER TRUCK EQUIPMENT
 P.O. BOX 482
 HURRICANE, WV 25526

S
H
I
P
T
O

DIVISION OF HIGHWAYS
 EQUIPMENT DIVISION
 ROUTE 33
 BRUSHY FORK ROAD
 BUCKHANNON, WV
 26201 304-472-1750

DATE PRINTED 05/18/2010	TERMS OF SALE NET 10 DAYS	SHIP VIA MOTOR FREIGHT	F.O.B. BUCKHANNON, WV	FREIGHT TERMS PREPAID
-----------------------------------	-------------------------------------	----------------------------------	---------------------------------	---------------------------------

BID OPENING DATE: **06/30/2010** BID OPENING TIME **01:30PM**

LINE	QUANTITY	UOP	CAT NO	ITEM NUMBER	UNIT PRICE	AMOUNT
EXHIBIT 2						
LIFE OF CONTRACT: THIS CONTRACT BECOMES EFFECTIVE ON AND EXTENDS FOR A PERIOD OF ONE (1) YEAR OR UNTIL SUCH "REASONABLE TIME" THEREAFTER AS IS NECESSARY TO OBTAIN A NEW CONTRACT OR RENEW THE ORIGINAL CONTRACT. THE "REASONABLE TIME" PERIOD SHALL NOT EXCEED TWELVE (12) MONTHS. DURING THIS "REASONABLE TIME" THE VENDOR MAY TERMINATE THIS CONTRACT FOR ANY REASON UPON GIVING THE DIRECTOR OF PURCHASING THIRTY (30) DAYS WRITTEN NOTICE.						
UNLESS SPECIFIC PROVISIONS ARE STIPULATED IN THIS CONTRACT DOCUMENT, THE TERMS, CONDITIONS, AND PRICING SET HEREIN ARE FIRM FOR THE LIFE OF THE CONTRACT.						
RENEWAL: THIS CONTRACT MAY BE RENEWED UPON THE MUTUAL WRITTEN CONSENT OF THE SPENDING UNIT AND VENDOR, SUBMITTED TO THE DIRECTOR OF PURCHASING THIRTY (30) DAYS PRIOR TO THE EXPIRATION DATE. SUCH RENEWAL SHALL BE IN ACCORDANCE WITH THE TERMS AND CONDITIONS OF THE ORIGINAL CONTRACT AND SHALL BE LIMITED TO TWO (2) ONE (1) YEAR PERIODS.						
CANCELLATION: THE DIRECTOR OF PURCHASING RESERVES THE RIGHT TO CANCEL THIS CONTRACT IMMEDIATELY UPON WRITTEN NOTICE TO THE VENDOR IF THE COMMODITIES AND/OR SERVICES SUPPLIED ARE OF AN INFERIOR QUALITY OR DO NOT CONFORM WITH THE SPECIFICATIONS OF THE BID AND CONTRACT HEREIN						
OPEN MARKET CLAUSE: THE DIRECTOR OF PURCHASING MAY AUTHORIZE A SPENDING UNIT TO PURCHASE ON THE OPEN MARKET, WITHOUT THE FILING OF A REQUISITION OR COST ESTIMATE, ITEMS SPECIFIED ON THIS CONTRACT FOR IMMEDIATE DELIVERY IN EMERGENCIES DUE TO UNFORESEEN CAUSES						

SEE REVERSE SIDE FOR TERMS AND CONDITIONS

SIGNATURE <i>Michael A. Austin</i>	TELEPHONE 304-722-3814	DATE 7/19/2010
TITLE SALESMAN	FEIN 55-0711783	ADDRESS CHANGES TO BE NOTED ABOVE

WHEN RESPONDING TO RFQ, INSERT NAME AND ADDRESS IN SPACE ABOVE LABELED 'VENDOR'



State of West Virginia
 Department of Administration
 Purchasing Division
 2019 Washington Street East
 Post Office Box 50130
 Charleston, WV 25305-0130

Request for Quotation

RFQ NUMBER
7010EC010

PAGE
4

ADDRESS CORRESPONDENCE TO ATTENTION OF
MICHAEL AUSTIN 304-558-2402

RFQ COPY

TYPE NAME/ADDRESS HERE

VENDOR

BAKER TRUCK EQUIPMENT
 P.O. BOX 482
 HURRICANE, WV 25526

SHIP TO

DIVISION OF HIGHWAYS
 EQUIPMENT DIVISION
 ROUTE 33
 BRUSHY FORK ROAD
 BUCKHANNON, WV
 26201 304-472-1750

DATE PRINTED	TERMS OF SALE	SHIP VIA	F.O.B.	FREIGHT TERMS
05/18/2010	NET 10 DAYS	MOTOR FREIGHT	BUCKHANNON, WV	PREPAID
BID OPENING DATE: 06/30/2010		BID OPENING TIME 01:30PM		

LINE	QUANTITY	UOP	CAT NO	ITEM NUMBER	UNIT PRICE	AMOUNT
<p>(INCLUDING BUT NOT LIMITED TO DELAYS IN TRANSPORTATION OR AN UNANTICIPATED INCREASE IN THE VOLUME OF WORK).</p> <p>QUANTITIES: QUANTITIES LISTED IN THE REQUISITION ARE APPROXIMATIONS ONLY, BASED ON ESTIMATES SUPPLIES BY THE STATE SPENDING UNIT. IT IS UNDERSTOOD AND AGREED THAT THE CONTRACT SHALL COVER THE QUANTITIES ACTUALLY ORDERED FOR DELIVERY DURING THE TERM OF CONTRACT, WHETHER MORE OR LESS THAN THE QUANTITIES SHOWN.</p> <p>ORDERING PROCEDURE: SPENDING UNIT(S) SHALL ISSUE A WRITTEN EQUIPMENT CONTRACT ORDER (FORM NUMBER WV-35) FOR COMMODITIES COVERED BY THIS CONTRACT. THE ORIGINAL WV-35 MUST BE SENT TO THE PURCHASING DIVISION OF THE DEPARTMENT OF ADMINISTRATION. AFTER APPROVAL AND ENCUMBRANCE, ONE COPY OF THE PURCHASE ORDER WILL BE RETURNED TO THE SPENDING UNIT AND ONE COPY FORWARDED TO THE VENDOR AS AUTHORIZATION FOR SHIPMENT. NO ORDER IS VALID UNLESS APPROVED AND ENCUMBERED BY THE PURCHASING DIVISION.</p> <p>BANKRUPTCY: IN THE EVENT THE VENDOR/CONTRACTOR FILES FOR BANKRUPTCY PROTECTION, THE STATE MAY DEEM THE CONTRACT NULL AND VOID, AND TERMINATE SUCH CONTRACT WITHOUT FUTHER ORDER.</p> <p>REV. 5/2009</p> <p>EXHIBIT 10</p> <p>REQUISITION NO.: 7010EC010.....</p> <p>ADDENDUM ACKNOWLEDGEMENT</p> <p>I HEREBY ACKNOWLEDGE RECEIPT OF THE FOLLOWING CHECKED</p>						

SEE REVERSE SIDE FOR TERMS AND CONDITIONS

SIGNATURE	TELEPHONE	DATE
<i>Michael Austin</i>	304-722-3814	7/19/2010
TITLE	EIN	ADDRESS CHANGES TO BE NOTED ABOVE
SALESMAN	55-0711783	

WHEN RESPONDING TO RFQ. INSERT NAME AND ADDRESS IN SPACE ABOVE LABELED 'VENDOR'



State of West Virginia
 Department of Administration
 Purchasing Division
 2019 Washington Street East
 Post Office Box 50130
 Charleston, WV 25305-0130

Request for Quotation

RFQ NUMBER
7010EC010

PAGE
5

ADDRESS CORRESPONDENCE TO ATTENTION OF
MICHAEL AUSTIN
304-558-2402

RFQ COPY
 TYPE NAME/ADDRESS HERE

BAKER TRUCK EQUIPMENT
 P.O. BOX 482
 HURRICANE, WV 25526

DIVISION OF HIGHWAYS
 EQUIPMENT DIVISION
 ROUTE 33
 BRUSHY FORK ROAD
 BUCKHANNON, WV
 26201 304-472-1750

DATE PRINTED 05/18/2010	TERMS OF SALE NET 10 DAYS	SHIP VIA MOTOR FREIGHT	F.O.B. BUCKHANNON, WV	FREIGHT TERMS PREPAID
BID OPENING DATE: 06/30/2010		BID OPENING TIME 01:30PM		

LINE	QUANTITY	UOP	CAT. NO.	ITEM NUMBER	UNIT PRICE	AMOUNT
<p>ADDENDUM(S) AND HAVE MADE THE NECESSARY REVISIONS TO MY PROPOSAL, PLANS AND/OR SPECIFICATION, ETC.</p> <p>ADDENDUM NO.'S:</p> <p>NO. 1 X</p> <p>NO. 2 .. X.....</p> <p>NO. 3</p> <p>NO. 4</p> <p>NO. 5</p> <p>I UNDERSTAND THAT FAILURE TO CONFIRM THE RECEIPT OF THE ADDENDUM(S) MAY BE CAUSE FOR REJECTION OF BIDS.</p> <p>VENDOR MUST CLEARLY UNDERSTAND THAT ANY VERBAL REPRESENTATION MADE OR ASSUMED TO BE MADE DURING ANY ORAL DISCUSSION HELD BETWEEN VENDOR'S REPRESENTATIVES AND ANY STATE PERSONNEL IS NOT BINDING. ONLY THE INFORMATION ISSUED IN WRITING AND ADDED TO THE SPECIFICATIONS BY AN OFFICIAL ADDENDUM IS BINDING.</p> <p>..... SIGNATURE</p> <p>..... BAKER TRUCK EQUIPMENT..... COMPANY</p> <p>..... 7/19/2010..... DATE</p>						

SEE REVERSE SIDE FOR TERMS AND CONDITIONS

SIGNATURE <i>James A. Mayer</i>	TELEPHONE 304-722-3814	DATE 7/19/2010
TITLE SALESMAN	FAX 55-0711783	ADDRESS CHANGES TO BE NOTED ABOVE

WHEN RESPONDING TO RFQ, INSERT NAME AND ADDRESS IN SPACE ABOVE LABELED 'VENDOR'



State of West Virginia
 Department of Administration
 Purchasing Division
 2019 Washington Street East
 Post Office Box 50130
 Charleston, WV 25305-0130

Request for Quotation

RFQ NUMBER
7010EC010

PAGE
6

ADDRESS CORRESPONDENCE TO ATTENTION OF
MICHAEL AUSTIN
304-558-2402

VENDOR

RFQ COPY
 TYPE NAME/ADDRESS HERE

BAKER TRUCK EQUIPMENT
 P.O. BOX 482
 HURRICANE, WV 25526

SHIP TO

DIVISION OF HIGHWAYS
 EQUIPMENT DIVISION
 ROUTE 33
 BRUSHY FORK ROAD
 BUCKHANNON, WV
 26201 304-472-1750

DATE PRINTED 05/18/2010	TERMS OF SALE NET 10 DAYS	SHIP VIA MOTOR FREIGHT	F.O.B. BUCKHANNON, WV	FREIGHT TERMS PREPAID
BID OPENING DATE: 06/30/2010		BID OPENING TIME 01:30PM		

LINE	QUANTITY	UOP	CAT NO	ITEM NUMBER	UNIT PRICE	AMOUNT
<p>NOTE: THIS ADDENDUM ACKNOWLEDGEMENT SHOULD BE SUBMITTED WITH THE BID.</p> <p>REV. 09/21/2009</p> <p>EXHIBIT 4</p> <p>LOCAL GOVERNMENT BODIES: UNLESS THE VENDOR INDICATES IN THE BID HIS REFUSAL TO EXTEND THE PRICES, TERMS, AND CONDITIONS OF THE BID TO COUNTY, SCHOOL, MUNICIPAL AND OTHER LOCAL GOVERNMENT BODIES, THE BID SHALL EXTEND TO POLITICAL SUBDIVISIONS OF THE STATE OF WEST VIRGINIA. IF THE VENDOR DOES NOT WISH TO EXTEND THE PRICES, TERMS, AND CONDITIONS OF THE BID TO ALL POLITICAL SUBDIVISIONS OF THE STATE, THE VENDOR MUST CLEARLY INDICATE SUCH REFUSAL IN HIS BID. SUCH REFUSAL SHALL NOT PREJUDICE THE AWARD OF THIS CONTRACT IN ANY MANNER.</p> <p>REV. 3/88</p> <p style="text-align: center;">NOTICE</p> <p>A SIGNED BID MUST BE SUBMITTED TO:</p> <p style="text-align: center;">DEPARTMENT OF ADMINISTRATION PURCHASING DIVISION BUILDING 15 2019 WASHINGTON STREET, EAST CHARLESTON, WV 25305-0130</p> <p>THE BID SHOULD CONTAIN THIS INFORMATION ON THE FACE OF THE ENVELOPE OR THE BID MAY NOT BE CONSIDERED:</p>						

SEE REVERSE SIDE FOR TERMS AND CONDITIONS

SIGNATURE 	TELEPHONE 304-722-3814	DATE 7/19/2010
TITLE SALESMAN	FAX 55-0711783	ADDRESS CHANGES TO BE NOTED ABOVE

WHEN RESPONDING TO RFQ INSERT NAME AND ADDRESS IN SPACE ABOVE LABELLED 'VENDOR'



State of West Virginia
 Department of Administration
 Purchasing Division
 2019 Washington Street East
 Post Office Box 50130
 Charleston, WV 25305-0130

Request for Quotation

RFQ NUMBER
7010EC010

PAGE
7

ADDRESS CORRESPONDENCE TO ATTENTION OF
MICHAEL AUSTIN
304-558-2402

RFQ COPY
 TYPE NAME/ADDRESS HERE

BAKER TRUCK EQUIPMENT
 P.O. BOX 482
 HURRICANE, WV 25526

DIVISION OF HIGHWAYS
 EQUIPMENT DIVISION
 ROUTE 33
 BRUSHY FORK ROAD
 BUCKHANNON, WV
 26201 304-472-1750

DATE PRINTED	TERMS OF SALE	SHIP VIA	F.O.B.	FREIGHT TERMS
05/18/2010	NET 10 DAYS	MOTOR FREIGHT	BUCKHANNON, WV	PREPAID

BID OPENING DATE: **06/30/2010** BID OPENING TIME **01:30PM**

LINE	QUANTITY	UOP	CAT NO	ITEM NUMBER	UNIT PRICE	AMOUNT
	SEALED BID					
	BUYER: 33					
	RFQ. NO.: 7010EC010					
	BID OPENING DATE: 06/30/2010					
	BID OPENING TIME: 1:30 PM					
	PLEASE PROVIDE A FAX NUMBER IN CASE IT IS NECESSARY TO CONTACT YOU REGARDING YOUR BID: 304-722-3829					
	CONTACT PERSON (PLEASE PRINT CLEARLY): VIRGIL MAYSE					
	***** THIS IS THE END OF RFQ 7010EC010 *****					
					PRICE EACH:	10 FT. - \$6,415.00
					TOTAL:	11 FT. - \$6,953.00

SEE REVERSE SIDE FOR TERMS AND CONDITIONS

SIGNATURE: *Virgil Mayse* TELEPHONE: 304-722-3814 DATE: 7/19/2010

TITLE: SALESMAN FAX: 55-0711783 ADDRESS CHANGES TO BE NOTED ABOVE

WHEN RESPONDING TO RFQ, INSERT NAME AND ADDRESS IN SPACE ABOVE LABELED 'VENDOR'

WEST VIRGINIA DEPARTMENT OF TRANSPORTATION
DIVISION OF HIGHWAYS
EQUIPMENT DIVISION

PROCUREMENT SPECIFICATIONS
NO. 021-2-D

OPEN END CONTRACT
10 FOOT OR 11 FOOT POWER REVERSIBLE SNOWPLOW (HYDRAULIC)

1.0 PURPOSE

It is the purpose of these specifications to describe a 10 Foot or 11 Foot Power Reversible Snowplow (Hydraulic) (hereinafter referred to as a "plow" or a "unit") to be purchased for use by the West Virginia Division of Highways (DOH) on an Open End Contract basis.

2.0 BIDDING PROCEDURES

The current purchasing procedures regarding bidding as established by the Department of Administration, Purchasing Division, shall apply. Failure to submit the "Request for Quotation" forms, complete in its entirety and according to directions indicated, may subject the bidder to disqualification. **Each bid submitted shall also be accompanied by a Bidder's Evaluation Report completed in detail.** Addendums in order, along with exception sheets, should be with Bidder's Evaluation Report. **FAILURE TO SUBMIT THE BIDDER'S EVALUATION REPORT, COMPLETE IN ITS ENTIRETY, MAY RESULT IN AUTOMATIC DISQUALIFICATION.**

3.0 SPECIFICATIONS

The specifications named herein, mandatory and non-mandatory, establish the acceptable level of quality only and are not intended to reflect a preference or favor any particular brand or vendor.

3.1 EXCEPTIONS TO NON-MANDATORY SPECIFICATIONS

Exception to a non-mandatory unit specification may be made by the bidder, providing the exception is not available from the manufacturer. **Any such exceptions must be noted on the bidder's evaluation report and should be accompanied by supporting documentation/literature from the manufacturer. A summary of exceptions must be prepared by vendor on a separate attachment to the bidder's evaluation report labeled as "Exception to Specifications" and should be provided with the bid.** The state reserves the right to determine whether the stated exception does or does not reduce the quality and performance of the unit. Failure to provide information for any exceptions may be grounds for rejection of the bid. The state reserves the right to waive minor irregularities in bids or specifications in accordance with §148-1-4(f) of the WV Legislative Rules and Regulations.

3.2 MANDATORY SPECIFICATIONS

All specifications preceded by "shall, will, and/or must" or are stated as a "minimum and/or maximum" are mandatory. Any bid failing to meet any mandatory item shall be immediately disqualified. Failure to respond in the appropriate evaluation section may also be grounds for immediate disqualification at the discretion of the State.

A mandatory pre-bid conference is scheduled for this equipment purchase as stated in the RFQ. Vendors having products with variations or exceptions in specified mandatory items are expected to address any such variations or exceptions during the pre-bid conference. **The State shall review and consider any such variation or exception, and may at its sole discretion, issue an addendum to change mandatory specifications deemed to be in the State's best interest. Bids from any vendor failing to attend the mandatory pre-bid shall be disqualified. Bids containing any variation or exception to a mandatory specification that was not addressed during the pre-bid conference and accepted by the issuance of an Addendum shall be disqualified.**

4.0 REPRESENTATIVE UNIT FOR TEST

The successful vendor must (if specified) provide DOH one (1) completed representative unit to be observed and evaluated on each order to insure compliance with specification. If requested, the time period for testing and evaluation shall be seven (7) working days following receipt of the unit. DOH will incur no obligation for deterioration of surfaces, finishes, seals, and mechanical or electrical parts on the unit resulting from operation and testing within the limits of these specifications; nor will DOH incur obligation for damage to the unit resulting from failure to meet specifications when due care and attention is given by DOH and testing is done within the limits of these specifications. **Failure of the pilot unit to satisfactorily meet specifications as bid shall be cause for cancellation of the purchase order, and return of the delivered unit along with all associated equipment to the vendor at the vendor's expense.**

4.1 CONDITION OF UNIT(S) UPON DELIVERY

All units must arrive at the prescribed delivery point having been completely preserviced with oil, lubricants, and coolant. All prescribed precautions pertaining to first operations and break-in of the unit are to be posted conspicuously on the unit for ready observance by the operator.

4.2 DELIVERY

Delivery point of the completely assembled representative unit will be the DOH, Equipment Division, Route 33 at Brushy Fork Road, Buckhannon, West Virginia (26201).

The vendor is responsible for guaranteeing delivery of the completed units within the time specified and agreed to by the State. Delivery is preferred within 135 days after

receipt of purchase agreement. The vendor is responsible for establishing and coordinating delivery terms with allied manufacturers or suppliers. **Delivery terms shall be stated in the bid and the State reserves the right to accept or negotiate such terms.** Failure to reach an agreement may result in rejection of the bid. **The successful bidder shall provide their manufacturer's confirmation of the order to the WVDOH contact person within seven (7) working days after receiving the approved purchase order.**

A completed pilot model for inspection must be provided within 45 calendar days after receipt of the purchase agreement by the successful vendor.

Delivery is an integral part of this specification and failure to comply will be cause to initiate a D.O.T. Administrative Form WV-82, Vendor Performance Form. The WV-82 Form will provide a means of officially notifying the Purchasing Division and the vendor of unsatisfactory performance; such as late deliveries, poor service, inadequate parts supplies, etc.

The decision to initiate subject Form will be at the sole discretion of the D.O.H. Commissioner's established Equipment Review Board.

Issuance of the WV-82 Vendor Complaint Form on unsatisfactory delivery against any vendor will be cause to refuse to consider similar items from those vendors on future Request For Quotations.

(NOTE: Delivery time could be altered due to labor strikes, severe inclement weather conditions, etc.)

5.0 AWARD CRITERIA

- 5.1 DOH will recommend the award in accordance with the RFQ evaluation criteria described in the requisition. **The award shall be made to the lowest unit cost vendor that meets or exceeds the specifications.** DOH reserves the right to place multiple orders in any quantity.

6.0 SPECIFICATIONS AND GUIDELINES - GENERAL

6.1 IDENTIFICATION OF THE UNIT BEING PROPOSED

The bidder must identify the unit by manufacturer, model, series, and year of manufacture, in the bid to enable identification by DOH in the manufacturer's specifications of the proposed unit. The bidder will submit complete descriptive literature of the proposed unit, to establish that the bid is the manufacturer's most current model, including latest engineering improvements, which have been, or will imminently be, regularly advertised and sold on the open market. The unit specified herein and offered to be manufactured after January 1, 2010 and be clearly identified and marked with date of manufacture.

6.2 OPERATING AND SERVICE MANUALS AND PARTS LISTS

An operator's manual must be included with each unit upon delivery. A "line sheet" (if applicable) and Equipment Preventative Maintenance Questionnaire (as shown in X6.2 of the Bidder's Evaluation Report) must be with pilot unit upon delivery. In addition, there must be 12 service, shop, or maintenance manuals; ten (10) to be distributed to the Districts and two (2) for the Equipment Division. Also, there must be 14 parts manuals; ten (10) to be distributed to the Districts and four (4) for Equipment Division use. CD ROM is preferred in lieu of parts and service manuals.

*** NOTE: MANUALS SHALL BE DELIVERED UPON COMPLETION OF DELIVERY OF TOTAL UNITS. FAILURE TO DO SO WILL DELAY PAYMENT.**

6.3 TRAINING:

Manufacturers and/or dealers will be required to stage a thorough seminar on the subjects of Preventative Maintenance, Operator and Mechanic Training. **In order to keep the operators and mechanics updated, the successful vendor shall conduct training with each purchase order against this open end contract.** Training is preferred within 2 working days after delivery of the pilot unit on the individual purchase order.

Manufacturers and/or dealers shall be required to furnish the Training Academy with one (1) Operator's Manual to be shipped direct to WVDOH Training Academy, Post Office Box 610, Buckhannon, West Virginia 26201 prior to delivery of the pilot.

The seminar to be held at the W. Va. Division of Highways, Equipment Division, Buckhannon, West Virginia.

6.4 PREVENTIVE MAINTENANCE AND OPERATOR PROCEDURES:

Manufacturers and/or dealers will be required to submit to the Equipment Division, in addition to the operating and service manuals, booklets and pamphlets explaining the Preventive Maintenance and Operator Procedures to be used by the operators of this equipment, and must include such things as daily prestart inspection procedure, service schedule, and routine maintenance required, safety precautions, etc.

The successful vendor shall furnish all training aids; i.e., videos, projectors, etc. required in conducting the training.

6.5 WARRANTY AND SERVICE POLICY

The Manufacturers warranty or service policy is to apply to the unit. Such warranty or service policy is to be recognized at any authorized unit dealer, representing manufacturer of proposed unit throughout the State of West Virginia. The applicable warranty or service policy will not be contingent upon obtaining routine service,

lubrication, and servicing of the unit from factory authorized agencies. It will be the responsibility of the bidder to have available labor to repair or replace any defective replacement parts, components and materials, and to have available those replacement parts, components, and/or materials found to be defective during the terms of the warranty period. The bidder should state the labor rates, locations where parts will be stocked, availability of parts, and discounts offered for parts, when terms of the warranty offer a pro-rated cost for parts and labor. In addition, the successful bidder should offer field work to repair or replace defective parts, components, and materials found to be defective during the terms of the warranty and should provide mechanic's travel rates, mileage charges, field mechanic rates, and any surcharge for miscellaneous items, if applicable, for field work during the warranty period. Submit to Division of Highways any technical or engineering improvements during the term of the warranty. **The unit must be accompanied upon delivery by the unit's manufacturer's executed warranty or service policy.**

A mandatory minimum two (2) year bumper to bumper basic parts and labor warranty excluding abuse and normal wear items is required for this unit.

THE "WARRANTY AND SERVICE POLICY QUESTIONNAIRE" ATTACHED IN THE BIDDER'S EVALUATION REPORT MUST BE COMPLETED IN ITS ENTIRETY AND SUBMITTED WITH YOUR BID. (SEE SECTION X6.5 OF BIDDER'S EVALUATION REPORT).

6.6 EVALUATION COMMITTEE REQUIREMENTS

Detailed component specifications, product literature, component models, required for specification compliance determination by the Evaluation Committee should be provided with each bid. Any information supplied that is contrary to/or conflicting with the specifications and/or attached Bidders Evaluation Report may be sufficient cause for rejection of bid.

6.7 UNSPECIFIED ACCESSORIES & FEATURES

All parts, equipment, accessories, material, design and performance characteristics not specified herein, but which are necessary to provide a complete unit, must be furnished with each unit and required to conform to strength, quality of material, and quality of workmanship to those which are advertised and provided to the market in general by the unit industry.

All parts and accessories advertised and regularly supplied as standard shall be included, except those which would represent duplication of these specified, and except those which, by specification, are not to be furnished. All standard safety features, required by Federal and State Law, shall be included.

7.0 SPECIFICATIONS OF THE QUOTED UNIT ARE AS FOLLOWS:

The hydraulically reversible snowplow to be designed for mounting on a single axle or tandem dump truck. The snowplow to be capable of plowing to the right or left at an angle of approximately thirty-five degrees (35°) discharging snow to the right or left. It should have a center mounted trip spring leaving the plow area outside the reversing arc free for nesting close to the pushing vehicle. It should be a straight blade type with an integral type snow shield.

The hydraulic power for lifting and reversing will be supplied by the truck central hydraulic system; however, the vendor shall supply the hose and fittings to connect both systems to the valve located under the front bumper.

The blade to be the sectional type, made up of three (3) and four (4) foot sections to total 10 feet or 11 feet wide, having a tungsten carbide inserted cutting edge.

The snowplow to be a Henderson RSP Reversible Snowplow or equal.

7.1 Moldboard:

7.1.1 Overall Width:

7.1.1.1 **OPTION #1 - 10 Foot**

7.1.1.2 **OPTION #2 - 11 Foot**

7.1.2 Overall Height: 36 Inches

7.1.3 **Moldboard Construction: 10 US Ga. 304 Stainless Steel minimum** and rolled to give the snow a free rolling action. Break formed not acceptable.

7.1.4 **Travel Arc: Thirty-five degrees (35°) minimum each way; total seventy degrees (70°).**

7.1.5 **Moldboard shall have a cutting edge attack angle with three (3) different adjustments from 5 Degree, 10 Degree, and 20 Degree vertical measurement from ground using ¾ inch pins.**

7.1.6 Weight of Plow: 10 foot - 1750 pounds 11 foot – 1815 pounds

7.1.7 **Vertical Ribs: Minimum of eight (8) vertical ribs, ½ inch x 3-1/2 inch formed steel.**

- 7.1.8 Snow Shield: An additional rubber snow shield to be provided. It should be approximately 5/16 inch x 12 inch belting and run the entire length of plow. Mounted in such a manner as not to add to overall plow height.
- 7.1.9 To be all continuously welded ribs, moldboard, and angles.
- 7.1.10 **Shall be reinforced at the top and bottom edges.** Top of the moldboard to be reinforced with an integrally structural channel 3-1/2 inch x 2-1/2 inch x 3/8 inch. Formed not acceptable. Bottom angle of not less than 4 inch x 4 inch x 3/4 inch angle gusseted.
- 7.2 Cutting Edge:
- 7.2.1 **The cutting edge shall be sectioned, standard AASHO punched, in three (3) foot and four (4) foot lengths.**
- 7.2.2 Blade Sections:
- 7.2.2.1 To be **minimum 1/2 inch thick by six (6) inches wide** having a GRADE WC cemented tungsten carbide insert of approximately 88 Rockwell A scale hardness.
- 7.2.2.2 The insert to be silver soldered on all sides of a milled slot near the center of the working edge.
- 7.2.2.3 The braze joint to have a transverse rupture strength of **345,000 PSI minimum**
- 7.2.2.4 **Blade section must be identifiable by manufacturer, name and part number stamped on the reverse side of each section.**
- 7.2.2.5 Wrap around curb guards to be mounted right and left side of plow
- 7.2.2.6 Curb guards to be 5/8 inch thick, approximately 6 inches high, and 8 inches long
- 7.3 Safety Trip Mechanism:
- 7.3.1 **Tripping mechanism must be attached to semi-circle and moldboard ribs and shall use two (2) compressions springs.**
- 7.3.2 **Springs shall be two (2) external compression springs sitting inside two (2) moldboard adjusting struts made from (2) 1/2 inch x 2.5 inch bars sliding to a 3/4 inch x 2.5 inch center bar with an overall length of 39.5 inches**
- 7.3.3 **The trip mechanism must hold the plow rigid in the plowing position and trip automatically when the cutting edge comes in contact with an obstruction then return to normal plowing position.**

7.4 Push Frame:

- 7.4.1 **Push frame shall be of all welded construction designed per manufacturer's heavy duty specifications. Push frame shall be no less than 120 inches in length for 10 foot and 132 inches in length for 11 foot plow made of x 4 inch x 4inch x 3/8 inch structural tube.**
- 7.4.2 **Moldboard to push frame connection to be by a minimum of seven (7) hinges with each hinge having a fully welded in bushing to house pin. Bushings shall be 1-1/4 inches mounted to two (2) 5/8 inch mounting ears for total bearing surface per bushing of 2-1/2 inch.**
- 7.4.3 **The plow push frame shall be equipped with an oscillating center pin of plow portion hitch of 2 inch with push plate being 1 inch x 33 inches x 5 inches feature to permit the plow to follow uneven road surfaces. Semi-Circle shall be 3-1/2 inch x 3-1/2 inch x 1/2 inch.**
- 7.4.3.1 **Push frame shall be equipped with a quick hitch connection system specific for WVDOH.**
- 7.4.4 **Hydraulic Power Reversing Mechanism:**
 - 7.4.4.1 **Shall be two (2) double acting 4 inch x 2 inch x 10inch power reversing nitrated hydraulic cylinders fitted with the fixed base end near the center of the push frame. Cylinders shall be mounted above the semi-circle.**
 - 7.4.4.2 **Hydraulic power reverse mechanism shall include a dual cross-over relief cushion valve rated at a minimum of 40 G.P.M.**
 - 7.4.4.3 **The "A" frame is made from 4 inch channel with 2.5 inch flanges supporting a 2 inch center reversing pin mounted in a 3 inch, 1/2 inch wall tube and having a grease fitting. The push ends are welded to a 1 inch x 33 inches x 5 inch base plate having a 2 inch pivot hole for the oscillator bar to attach to.**
- 7.4.5 **Skid Shoes:**
 - 7.4.5.1 **Caster mounted carbide mushroom type shoes, one (1) each side shall be provided.**
 - 7.4.5.2 **Manufacturer's standard adjusting mechanism shall be included.**

7.5 Hitch:

- 7.5.1 Designed as a universal heavy duty type unit to carry plows of weight specified when mounted on **32,000 pound class trucks minimum.**
- 7.5.2 **The hitch shall be a bumper to frame type universally adaptable to any conventional truck and to accommodate the tilt front end on the carrier.**
- 7.5.2.1 **Hitch shall be attached to truck's frame rails.**
- 7.5.2.2 Hitch to include a lift system designed at a **rated capacity of 8,000 lbs minimum. Lift cylinder must be same size as plows reversing cylinder for WVDOH's interchangeability.**
- 7.5.3 Truck Portion Hitch Attachment of WVDOH quick release design.:
- 7.5.3.1 **Hitch frame height shall be 33- 5/8 inches and hitch width of 26 inches**
- 7.5.3.2 Hitch frame members are ½ inch x 4 inch x 4 inch structural angle or tubing. This hitch is low profile for access to the truck's engine compartment.
- 7.5.3.3 **The lift arm and lift frame shall be designed to accept a 4 inch lift cylinder with nitrided cylinder tube. Cylinders pins are to be 1 inch cold rolled steel..**
- 7.5.3.4 Self-storing lift arm, accomplished by pulling one 1 inch pin and folding the cylinder up, allows you to re-pin to store.
- 7.5.3.5 **The telescopic lift arm shall be manufactured of 4 inch x 4 inch x 3/8 inch square outer tubing and 3 inch x 3 inch x 3/8 inch square inner tubing. The lifting plate shall be 3/8 inch x 4 inch flat material and have two (2) banjo-type chain eyes able to accept ½ inch chain as well as the weight of the plow. Shall also have two (2) stabilizer arms mounted to receiver tube of telescoping arm and outside pivot of hitch.**
- 7.5.4 **Shall provide custom ½ inch Grade 50 or better cheek plates are to be bolted welded or bolted to main hitch and to allow for bolting to truck's frame rail.**
- 7.6 **Hydraulic System: Hydraulic pressure will be supplied from the truck central hydraulic system through a lift valve and reversing valve (main bank valve) to the plow lift and reversing cylinders. The vendor shall be required to supply the following hydraulic components:**
- 7.6.1 **One (1) 4 inch lift cylinder with 10 inch stroke double-acting nitrided hydraulic lift cylinder (even if we only use one (1) line fitting in upper end with breather), clevis pinned top and bottom.**

- 7.6.2 Two (2) four (4) inch double acting nitrated hydraulic reversing cylinders
- 7.6.3 Three (3) pieces of two (2) wire hydraulic pressure hose one-quarter (1/4) inch diameter and approximately ten (10) feet long. Each hose must be equipped with:
 - 7.6.3.1 One (1) quick coupler at plow end with dust caps. Prefer Snap-Tite Couplers VHN-8 Nipple Hose, VHN-8 Nipple Reverse Cylinder, VHC-8 Nipple Reverse Cylinder 90° Fitting.
 - 7.6.3.2 Two (2) crimp-type hose fittings with male JIC 370 threads. One (1) to mate with swivel and the other to mate with quick coupler.
 - 7.6.3.3 One (1) JIC 370 - swivel - 90° elbow/male JIC 370.
 - 7.6.3.4 One (1) adaptor to mate bank valve port to JIC swivel.
- 7.7 Unit shall include all other features considered as standard equipment but not specifically addressed above.
- 7.8 Vendor must certify that snowplow offered will comply with Occupational Safety and Health Act of 1970 and subsequent amendments.
- 7.9 It is the intention of the West Virginia Division of Highways to secure a close fitting, simple, reversible snowplow that will be designed to operate as close as possible to the vehicle pushing it, to maintain truck balance within reasonable limits.

Key features for acceptability will be a relatively light weight compact unit. Lift by cable acceptable providing side shifting of cable is not impeded by lift point device.

Vendors are cautioned that a push frame and/or hitch assembly designed without regard to overall distance of truck to front of plow which would jeopardize truck balance may be judged as not conforming to these specifications.
- 7.10 Paint: The entire unit to not be painted but rather Powder Coated in accordance with West Virginia Division of Highways requirements as follows:
 - 7.10.1 The entire unit to be sandblasted and thoroughly cleaned, free of rust, grease, and scale. All surfaces are high-pressure cleaned and degreased with phosphate solution prior to powder coating.
 - 7.10.2 The complete assembly to receive one (1) layer of powder coating.

- 7.10.3 The front of the plow to be given one (1) layer of powder coating Federal Yellow (No. 93-6578) DuPont Deluxe equipment enamel or equal quality powder of other manufacturer.
- 7.10.4 The rear of the plow to be given one (1) layer of powder coating of manufacturer's standard Black (Flat) equipment enamel.
- 7.10.5 The push frame and hitch to be given one (1) layer of powder coating of manufacturer's standard Black (Flat) equipment enamel. **Complete coverage of the push frame and hitch is mandatory.**
- 7.11 Advertising: Manufacturer shall attach a metal plate on the reverse side of moldboard stating manufacturer, series or model number, size and type of blade (approximately six (6) inch to eight (8) inch square). Date of manufacture shall also be stamped on the plate or the moldboard. No large decals or painted advertisement are permitted.**
- 7.12 All loose hardware to be in a separate container for each plow and shipped with each plow.

WEST VIRGINIA DEPARTMENT OF TRANSPORTATION
 DIVISION OF HIGHWAYS
 EQUIPMENT DIVISION

BIDDER'S EVALUATION REPORT

PROCUREMENT SPECIFICATIONS
 NO. 021-2-D

OPEN END CONTRACT
 10 FOOT OR 11 FOOT POWER REVERSIBLE SNOWPLOW (HYDRAULIC)

NOTE TO BIDDER: Procurement Specification No. 021-2-D, Paragraph 2.0 recommends the completion and submittal of this Report with your bid. Purpose of this Report is to enable the West Virginia Division of Highways Evaluation Committee to make full and fair evaluation of the bid. Addendums in order, along with a summary of exception as a separate attachment, should be with Bidder's Evaluation Report. FAILURE TO SUBMIT THIS REPORT, COMPLETE IN ITS ENTIRETY, MAY SUBJECT THE BIDDER TO DISQUALIFICATION.

Reference Requisition No.: 7010EC010

Bidder's Name: BAKER TRUCK EQUIPMENT

Address: P.O. BOX 482 HURRICANE, WV 25526

Telephone Number: 304-722-3814

Years Bidder has been registered to do business with the State of West Virginia: 15 YRS.

Years Company has been an authorized dealer for proposed unit: 15 YRS.

X3.2 Have you complied with all mandatory specifications? YES NO

X4.2 DELIVERY:

X4.2.1 Delivery date of completed representative unit: 45 Calendar Days After
 Receipt of Purchase Agreement

X4.2.2 Delivery date of balance of completed units: 135 Calendar Days After Receipt of
 Purchase Agreement

NOTE: Vendor should type Bidder's Evaluation Report

The *Bidder's Evaluation Reports* are ready for download on Purchasing's Web site at www.state.wv.us/admin/purchase

X5.0 AWARD CRITERIA;

X5.1 Price per unit:

10 FT. - \$6,415.00 per unit

11 FT. - \$6,953.00 per unit

X6.0 SPECIFICATIONS - GENERAL

X6.1 Manufacturer, model, series, and date of manufacture of proposed unit:

HENDERSON MODEL #RSP-WV2010 2010 MODELIs descriptive literature, fully describing proposed unit attached to your bid? YES NO

If not, why? _____

X6.2 Will the required number of service manuals, and complete parts list be delivered to the Equipment Division at Buckhannon upon completion of delivery of total units?

 YES NOWill the required Equipment Preventive Maintenance Form (Section X6.2 of Bidders Evaluation Report) be provided upon inspection of the pilot unit? YES NO

X6.2
2-10-00

EQUIPMENT PREVENTATIVE MAINTENANCE QUESTIONNAIRE

THIS FORM MUST BE COMPLETED IN ITS ENTIRETY BY SUCCESSFUL BIDDER OR MANUFACTURER'S TECHNICAL REPRESENTATIVE PRIOR TO DELIVERY OF PILOT MODEL TO THE WVDOH.

DESCRIPTION: _____ MAKE: _____

MODEL: _____ YEAR: _____ PURCHASE AMOUNT: _____

ENGINE: MAKE: _____ MODEL: _____ FUEL TYPE: _____

HORSEPOWER: _____ CYLINDER: _____ ENGINE SERIAL: _____

COOLING SYSTEM CAPACITY: _____

BELTS: DESCRIPTION: _____ PART NUMBERS: _____

GVW: _____ AXLE CAPACITY: FRONT: _____ REAR: _____

TIRES: FRONT MAKE & SIZE: _____

REAR MAKE & SIZE: _____

DIMENSIONS OF UNIT: LENGTH: _____ WIDTH: _____ LENGTH: _____

VENDOR CONTACT PERSON: _____ PHONE: _____

PARTS:

BATTERY MAKE: _____ MODEL: _____ CCA: _____

TOP OR SIDE POST: _____ DIMENSIONS: LENGTH _____ WIDTH _____ HEIGHT _____

SPARK PLUGS OR FUEL INJECTORS MAKE: _____ PART # _____

FUEL PUMP OR INJECTION PUMP MAKE: _____ MODEL: _____

ALTERNATOR MAKE: _____ PART #: _____

STARTER MAKE: _____ PART #: _____

TURBO CHARGER MAKE: _____ PART #: _____

TRANS. MAKE: _____ MODEL: _____ AUTO/MANUAL: _____

HYDRAULIC PUMP MAKE: _____ MODEL: _____

FILTERS	MAKE	PART NO.	LUBRICANT	MANUFACTURER TYPE
OIL	_____	_____	ENGINE	_____
AIR INNER	_____	_____	TRANSMISSION	_____
AIR OUTER	_____	_____	POWER STEERING	_____
FUEL PRIMARY	_____	_____	HYDRAULIC	_____
FUEL SECONDARY	_____	_____	DIFFERENTIALS	_____
COOLANT	_____	_____	BRAKE FLUID	_____
HYDRAULIC	_____	_____	COOLANT	_____
OTHER	_____	_____	OTHER	_____

X6.3 TRAINING:

Will training seminar be conducted on Preventive Maintenance, Operator and Mechanic Training
 YES NO

Will you conduct training with each purchase order against this open end contract?
 YES NO

Will training be conducted within 2 working days from the delivery of the pilot unit on the individual purchase order?
 YES NO

If NO, explain time frame _____

Will an Operator's Manual be furnished directly to Training Academy prior to the delivery of the pilot?
 YES NO

X6.4 If you are the successful vendor, will you furnish all training aids, i.e., videos, projectors, required in conducting the training?
 YES NO

X6.4.1 Will all manuals, booklets, etc. explaining preventive maintenance, operator procedures, and service schedule be delivered with each unit?
 YES NO
 If NO, explain _____

X6.5 WARRANTY AND SERVICE POLICY

Will the warranty and service you provide comply with all areas as stated in Section 6.5 of specifications
 YES NO

Is warranty literature attached? YES NO

Is a minimum two (2) year bumper to bumper basic parts and labor warranty excluding abuse and normal wear items included?
 YES NO

Describe:

SEE WARRANTY AGREEMENT AT END OF THIS REPORT.

X6.5 WARRANTY AND SERVICE POLICY QUESTIONNAIRE
THIS FORM MUST BE COMPLETED IN ITS ENTIRETY AND SUBMITTED WITH YOUR BID.

(If additional lines are needed, make copies of form.)

1. Define the terms of the standard warranty. If not offered, so state. (Attach copy)

SEE WARRANTY AGREEMENT AT THE END OF THIS REPORT.

2. Define warranty service to be performed at DOH facilities and warranty service to be performed at manufacturer's representative facility. List name and location of manufacturer's representative.

MOST WARRANTY WORK WILL HAVE TO BE PERFORMED AT BAKER TRUCK EQUIPMENT SOME MINOR WARRANTY ITEMS MAY BE PERFORMED AT D.O.H. FACILITIES WITH PRIOR APPROVAL ONLY.

3. List locations for parts inventories that are within the State of West Virginia. Also, list availability levels, if known.

BAKER TRUCK EQUIPMENT

4. During the term of warranty, list the guarantee discount to manufacturer's published list price for parts that bidder will sell the parts to owner.

- | | | |
|----|---------------|---|
| A. | Terms: Net 30 | Manufacturer's published list price less: <u>5</u> % discount |
| B. | Terms: Net 60 | Manufacturer's published list price less: <u>0</u> % discount |
| C. | Terms: Net 90 | Manufacturer's published list price less: <u>0</u> % discount |

5. During the term of warranty, will all manufacturers or engineering improvements be submitted to Division of Highways? X YES NO

6. During the term of warranty, list the guaranteed rates charged for repair to the unit.

- | | | |
|----|---|--|
| A. | Shop Rate | \$ <u>70.00</u> per mechanic hour |
| B. | Travel Time Charge
(Specify if one-way) | \$ <u>80.00</u> per mechanic hour *SEE NOTE
<u> </u> ; port to port <u>X</u> |
| C. | Mileage Charge
(Specify if one-way) | \$ <u>1.75</u> per vehicle mile *SEE NOTE
<u> </u> ; port to port <u>X</u> |
| D. | Field Mechanic Rate | \$ <u>80.00</u> per mechanic hour *SEE NOTE |
| E. | Specify period of time that prices are in effect: <u>SIX (6) MONTHS</u> | |
| F. | Surcharge for miscellaneous items: <u>0</u> % | |

*NOTE: HENDERSON MANUFACTURING DOES NOT PAY ANY WARRANTY ON TRAVEL TIME. ALL WARRANTY MUST BE COMPLETED AT THE AUTHORIZED DISTRIBUTOR'S FACILITY.

X6.6 EVALUATION COMMITTEE REQUIREMENTS

Is all component specifications, product literature, component models provided for Evaluation Committee bid determination? YES NO

X6.7 Will all parts, equipment, accessories, material, design and performance characteristics not specified herein, but which are necessary to provide a complete unit, be furnished with the unit and conform in strength, quality of material, and quality of workmanship to those which are advertised and provided to the market in general by the unit industry?

YES NO

X6.7.1 Are all parts and accessories adequate and regularly supplied as standard to be included except those which may be duplications of specifications herein, and except these by specification are not to be furnished?

YES NO

X6.7.2 Are all standard safety features that are required by Federal and State statutes of law included?

YES NO

X7.0 SPECIFICATIONS OF THE QUOTED UNIT

The bidder should complete the following schedule in order for the Division to compare the actual bid unit to the specifications. Should the bidder except a requirement, then such exception may be only on the basis that such feature is not offered by the manufacturer. The Division will have the sole discretion as to whether the bidder's substitution meets the requirements of the specifications. by the manufacturer. The Division will have the sole discretion as to whether the bidder's substitution meets the requirements of the specifications.

Is the snowplow designed for mounting on a single axle or tandem dump truck

YES NO

Is the snowplow capable of plowing to the right or left at an angle approximately 35° discharging to the right or left

YES NO

Does it have a center mounted trip spring leaving the plow area outside the reversing arc free for nesting close to the pushing vehicle

YES NO SEE ADDENDUM #2

Is it a straight blade type with an integral type snow shield

YES NO SEE ADDENDUM #2

Will you supply the hose and fittings to connect both systems to the valve located under the front bumper

YES NO

Is the blade section type, made up of three (3) and four (4) foot sections to total 10 feet or 11 feet wide, having a tungsten carbide inserted cutting edge

YES NO

Manufacturer: PACAL/BUCYRUS

Model: NO MODEL # ON FILE
THEY ARE 3 AND 4 FOOT SECTIONS.
TUNGSTEN CARBIDE INSERTED CUTTING EDGES.

X7.1 Moldboard:

X7.1.1 Overall Width:

X7.1.1.1 **OPTION #1** – 10 Foot YES NOX7.1.1.2 **OPTION #2** – 11 Foot YES NOX7.1.2 Overall height: 36 inchesX7.1.3 **Moldboard construction:** 10 U.S. Gauge 304 STAINLESS steel and rolled to give the snow a free rolling action YES NOX7.1.4 **Travel arc:** 35 ° each way; total 70 °X7.1.5 **Moldboard has a cutting edge attach angle with three (3) adjustments from 5 degree, 10 degree, and 20 degree vertical measurement from ground using 3/4 inch pins** YES NO

X7.1.6 Weight of plow: 10 foot _____ Lbs. 11 foot _____ Lbs. SEE ADDENDUM #2

X7.1.7 **Number of vertical ribs** 8 1/2 inch X 3-1/2 inch Formed steelX7.1.8 Is an additional rubber snow shield provided? YES NOSize of belting APPROXIMATELY 5/16" X 12" Run entire length of plow? YES NOMounted so it won't add to overall height? YES NOX7.1.9 Continuously welded ribs, moldboard, and angles YES NOX7.1.10 **Reinforced at top and bottom edges?** YES NOTop of moldboard reinforced with integrally structural channel? YES NOSize of channel: 3-1/2" X 2-1/2" X 3/8"Bottom angle 4 x 4 x 3/4 angle gusseted.

X7.2 Cutting Edge:

X7.2.1 **Sectioned, standard AASHO punched, in three (3) foot and four (4) foot lengths?** YES NO

X7.2.2 Blade Sections:

- X7.2.2.1 3/4 inch thick by 6 inches wide having a Grade WC cemented tungsten carbide insert of approximately 88 Rockwell A scale hardness? X YES NO
- X7.2.2.2 Insert silver soldered on all sides of a milled slot near the center of the working edge? X YES NO
- X7.2.2.3 Braze joint transverse rupture strength: 345,000 PSI
- X7.2.2.4 Blade section identifiable by manufacturer, name and part number stamped on the reverse side of each section? X YES NO
- X7.2.2.5 Will wrap around curb guards be mounted on right and left side of plow X YES NO
- X7.2.2.6 Curb guards are 5/8 inch thick, 6 inches high and 8 inches long

X7.3 Safety Trip Mechanism:

- X7.3.1 Tripping mechanism attached to semi-circle and moldboard ribs use two (2) compression springs X YES NO
- X7.3.2 Are springs two (2) external compression springs sitting inside (2) moldboard adjusting struts made from (2) 1/2 inch x 2.5 inch bars sliding to a 3/4 x 2.5 inch center bar with an overall length of 39.5 inches X YES NO
- X7.3.3 Does the trip mechanism hold the plow rigid in plowing position and trip automatically when cutting edge comes in contact with an obstruction then returns to normal plowing position? X YES NO

X7.4 Push Frame:

- X7.4.1 All welded construction designed per manufacturer's heavy duty specifications? X YES NO
- Push frame length for 10 foot: 120 inches Structural tube size: 4" x 4" x 3/8"
- Push frame length for 11 foot: 132 inches Structural tube size: 4" x 4" x 3/8"
- X7.4.2 Number of hinges in moldboard to push frame connection? MINIMUM OF 7
- Each hinge has a fully welded in bushing to house pin X YES NO
- Bushings are 1 1/4 inch mounted to two 5/8 inch mounting ears for total bearing surface per bushing of 2 1/2 inches X YES NO

- X7.4.3 Equipped with an oscillating center pin of plow portion hitch of 2 inch with push plate being 1 inch x 33 inches x 5 inches feature to permit plow to follow uneven road surfaces? YES NO
- Semi-circle is 3 ½ inches x 3 ½ inches x ½ inch YES NO
- X7.4.3.1 Is push frame equipped with a quick hitch connection system specific for WVDOH? YES NO SEE ADDENDUM #2
- X7.4.4 Hydraulic Power Reversing Mechanism:
- X7.4.4.1 Consist of two (2) double acting 4 inch x 2 inch x 10 inch power reversing hydraulic cylinders fitted with the fixed base end in the center of the push frame? YES NO
SEE ADDENDUM #2
- Are cylinders mounted above the semi-circle YES NO
SEE ADDENDUM #2
- X7.4.4.2 Does hydraulic power reverse mechanism include a dual cross-over relief cushion valve? YES NO
- Rated at 40 GPM
- X7.4.4.3 The "A" frame is made from 4 inch channel with 2.5 inch flanges supporting a 2 inch center reversing pin mounted in a 3 inch, 1/2 inch wall tube and having a grease fitting YES NO
- Push ends are welded to a 1 inch x 33 inch x 5 inch base plate having a 2 inch pivot hole for the oscillator bar to attach to YES NO
- X7.4.5 Skid Shoes:
- X7.4.5.1 Are caster mounted carbide mushroom type shoes included? YES NO
- One on each side YES NO
- X7.4.5.2 Manufacturer's standard adjusting mechanism included? YES NO
- X7.5 Hitch:
- X7.5.1 Universal heavy duty type designed to carry plows of weight specified when mounted on a **32,000 pound class truck minimum?** YES NO
- X7.5.2 Bumper to frame type universally adaptable to any conventional truck and to accommodate a tilt front end on the carrier? YES NO
SEE ADDENDUM #2
- X7.5.2.1 Is hitch attached in truck's frame rails? YES NO

X7.5.2.2 Does hitch include a lift system YES NO

Designed at a rated capacity of 8,000 lbs.

Is lift cylinder the same size as plows reversing cylinder for WVDOH interchangeability
 YES NO

X7.5.3 Hitch to Bumper Attachment:

X7.5.3.1 Is hitch frame height 33 5/8 inches and hitch width 26 inches YES NO

X7.5.3.2 Hitch members are 1/4 inches x 4 inches x 4 inches structural angle or tubing
 YES NO

Hitch is low profile for access to the truck's engine compartment YES NO

X7.5.3.3 Is the lift arm and lift frame designed to accept a 4 inch lift cylinder with nitrided cylinder tube?
 YES NO

Cylinder pins are 1 inch cold rolled steel YES NO

X7.5.3.4 Does unit have self-storing arm YES NO

Is this accomplished by pulling one (1)- one (1) inch pin and folding the cylinder up which allows you to re-pin to store?
 YES NO

X7.5.3.5 Axle clamp allows longitudinal motion but not vertical and horizontal motion?
 YES NO

X7.5.4 Does unit provide custom 1/2 inch Grade 50 or better check plates which are bolted welded or bolted to main hitch and allows for bolting to truck's frame rail YES NO

X7.6 Hydraulic System:

Will you supply the following hydraulic components YES NO

X7.6.1 Provide one (1) 4 inch lift cylinder with 10" stroke double-acting nitrided hydraulic lift cylinder, clevis pinned top and bottom? YES NO

X7.6.2 Provide two (2) four (4) inch double acting nitrided hydraulic reversing cylinders?
 YES NO

X7.6.3 Provide three (3) pieces of two (2) wire hydraulic pressure hose one-quarter (1/4) inch diameter by approximately ten (10) feet long? YES NO

Is each hose equipped with the following YES NO

- X7.6.3.1** Each hose equipped with one (1) quick coupler at plow end with dust cap? YES NO
Manufacturer/Model: SNAP-TITE VHN/VHC SERIES
- X7.6.3.2** Each hose equipped with two (2) crimp-type fittings with male JIC 370 threads (one (1) to mate with swivel and the other to mate with quick coupler)? YES NO
- X7.6.3.3** Each hose equipped with one (1) JIC 370 - swivel - 90° elbow/male JIC 370? YES NO
- X7.6.3.4** Each hose equipped with one (1) adaptor to mate bank valve port to JIC swivel? YES NO
- X7.7 Other Standard Features:**
List other standard features offered and not addressed above:
-
-
- X7.8** Does the proposed unit meet or exceeds the OSHA of 1970 and/or subsequent changes? YES NO
- X7.9** Is snowplow close fitting, simple, reversible snowplow that will be designed to operate as close as possible to the vehicle pushing it, to maintain truck balance within reasonable limits YES NO
- Is it a relatively light weight compact unit** YES NO
- Is push frame and/or hitch assembly designed with regard to overall distance of truck to front of plow which would jeopardize truck balance? YES NO
DESIGNED TO NOT JEOPARDIZE TRUCK BALANCE
- X7.10 Paint:**
- X7.10.1** Will unit be sandblasted and prepped prior to painting as stated in 7.10.1? YES NO
- X7.10.2** Will complete assembly receive one (1) layer of powder coating YES NO
SEE ADDENDUM #2
- X7.10.3** Describe painting of front of plow: TO BE GIVEN ONE LAYER OF POWDER COATING FEDERAL YELLOW (NO. 93-6578) DUPONT DELUXE EQUIPMENT ENAMEL.
- X7.10.4** Describe painting of rear of plow: TO BE GIVEN ONE LAYER OF BECKER PA2-01974M FLAT BLACK
- X7.10.5** Paint for push frame and hitch ONE LAYER OF BECKER PA2-01974M FLAT BLACK
- Will push frame and hitch be completely covered** YES NO
- X7.11** Does the unit conform to the advertising guidelines? YES NO
- X7.12** Will all loose hardware be in separate containers for each plow and be shipped with each plow? YES NO



State of West Virginia
 Department of Administration
 Purchasing Division
 2019 Washington Street East
 Post Office Box 50130
 Charleston, WV 25305-0130

Request for Quotation

RFQ NUMBER
 7010EC010

PAGE
 1

ADDRESS CORRESPONDENCE TO ATTENTION OF:
 MICHAEL AUSTIN
 304-558-2402

VENDOR

VIRGIL MAYSE
BAKER EQUIPMENT
 P O BOX 482
 HURRICANE WV 25526

SHIP TO

DIVISION OF HIGHWAYS
 EQUIPMENT DIVISION
 ROUTE 33
 BRUSHY FORK ROAD
 BUCKHANNON, WV
 26201 304-472-1750

DATE PRINTED	TERMS OF SALE	SHIP VIA	F.O.B.	FREIGHT TERMS
06/25/2010	NET 10 DAYS	MOTOR FREIGHT	BUCKHANNON, WV	PREPAID
BID OPENING DATE: 07/14/2010		BID OPENING TIME 01:30PM		

LINE	QUANTITY	UOP	CAT NO	ITEM NUMBER	UNIT PRICE	AMOUNT
***** ADDENDUM NO. 1 *****						
ADDENDUM ISSUED FOR THE POWER REVERSIBLE SNOWPLOW CONTRACT ADVERTISEMENT TO DELAY THE BID DATE. ADDENDUM NO.2 WILL CONTAIN SPECIFICATION CLARIFICATION AND WILL BE ISSUED SHORTLY.						
BID DATE AND OPENING TIME ARE EXTENDED FROM 06/30/10 TO 07/14/10 AT 1:30 PM.						
***** NO OTHER CHANGES *****						
0001	1	EA		765-59		
POWER REVERSIBLE SNOWPLOW						
***** THIS IS THE END OF RFQ 7010EC010 ***** TOTAL:						

JUN 29 2010

SEE REVERSE SIDE FOR TERMS AND CONDITIONS

SIGNATURE: *Virgil Mayse* TELEPHONE: 304-722-3814 DATE: 7/19/2010

TITLE: SALESMAN FIRM: 55-0711783 ADDRESS CHANGES TO BE NOTED ABOVE

WHEN RESPONDING TO RFQ INSERT NAME AND ADDRESS IN SPACE ABOVE LABELED 'VENDOR'



State of West Virginia
 Department of Administration
 Purchasing Division
 2019 Washington Street East
 Post Office Box 50130
 Charleston, WV 25305-0130

Request for Quotation

RFQ NUMBER
7010EC010

PAGE
1

ADDRESS CORRESPONDENCE TO ATTENTION OF
**BUYER 33
 304-558-2402**

***815133313 304-722-3814**
BAKER TRUCK EQUIPMENT COMPANY
PO BOX 482

HURRICANE WV 25526

DIVISION OF HIGHWAYS
EQUIPMENT DIVISION
ROUTE 33
BRUSHY FORK ROAD
BUCKHANNON, WV
26201 304-472-1750

DATE PRINTED	TERMS OF SALE	SHIP VIA	F.O.B.	FREIGHT TERMS
07/08/2010	NET 10 DAYS	MOTOR FREIGHT	BUCKHANNON, WV	PREPAID

BID OPENING DATE: **07/20/2010** BID OPENING TIME **01:30PM**

LINE	QUANTITY	UOP	CAT NO	ITEM NUMBER	UNIT PRICE	AMOUNT
***** ADDENDUM NO. 2 *****						
ADDENDUM ISSUED FOR THE POWER REVERSIBLE SNOWPLOW CONTRACT ADVERTISEMENT TO DISTRIBUTE THE PRE-BID SIGN-IN SHEETS AND THE REVISIONS TO THE BIDDER'S EVALUATION REPORT AND THE SPECIFICATIONS RESULTING FROM THE MANDATORY PRE-BID ON 06/10/10.						
BID OPENING DATE & TIME ARE EXTENDED FROM 07/14/10 TO 07/20/10 AT 1:30 PM.						
***** NO OTHER CHANGES *****						
0001	1	EA		765-59		
POWER REVERSIBLE SNOWPLOW						
***** THIS IS THE END OF RFQ 7010EC010 ***** TOTAL:						

SIGNATURE <i>[Signature]</i>			SEE REVERSE SIDE FOR TERMS AND CONDITIONS		TELEPHONE	DATE
TITLE SALESMAN			FAX 55-0711783		304-722-3814	7/19/2010
				ADDRESS CHANGES TO BE NOTED ABOVE		

WHEN RESPONDING TO RFQ, INSERT NAME AND ADDRESS IN SPACE ABOVE LABELED 'VENDOR'

PREBID ADDENDUM
OPEN END CONTRACT
7010EC10

10 FOOT AND 11 FOOT POWER REVERSIBLE SNOWPLOW

CHANGES TO BIDDER'S EVALUATION REPORT:

DELETE:

X7.0 SPECIFICATIONS OF THE QUOTED UNIT
(4th Paragraph)

Does it have a center mounted trip spring leaving the plow area outside the reversing arc free for nesting close to the pushing vehicle YES NO

ADD:

X7.0 SPECIFICATIONS OF THE QUOTED UNIT

Does it have two (2) trip springs setting inside the two (2) moldboard struts
 x YES NO

NO CHANGE REQUIRED:

X7.1.6 Weight of plow: 10 foot 1750 Lbs. 11 foot 1815 Lbs.

DELETE:

X7.4.3.1 Is push frame equipped with a quick hitch connection system specific for WVDOH YES NO - deleted spec not applicable

FROM:

X7.4.4.1 Consist of two (2) double acting 4 inch x 2 inch x 10 inch power reversing hydraulic cylinders fitted with the fixed base end in the center of the push frame? YES NO
Are cylinders mounted above the semi-circle YES NO

TO:

X7.4.4.1 Consist of two (2) double acting 4 inch x 2 inch power reversing hydraulic cylinders fitted with the fixed base end in the center of the push frame?
 x YES NO
Are cylinders mounted above the semi-circle x YES NO

The "Bidder's Evaluation Report" is available for download on Purchasing's Web site at www.state.wv.us/admin/purchase

**PreBid Addendum
Bidder's Evaluation Report**

FROM:
X7.5.2 **Bumper to frame type universally adaptable to any conventional truck and to accommodate a tilt front end on the carrier? YES NO**

TO:
X7.5.2 **Bumper to frame type adaptable to any conventional truck and to accommodate a tilt front end on the carrier? x YES NO**

FROM:
X7.10.2 **Will complete assembly receive one (1) layer of powder coating YES NO**

TO:
X7.10.2 **Will complete assembly receive one (1) layer of powder coating? x YES NO**

Will front be sprayed in enamel? YES x NO

HENDERSON PRODUCTS INC

Janet Tobin

Contract Administration Manager

COMPLETE WARRANTY PROVISIONS

A. PARTS REPLACEMENT AND REPAIR:

two years

Henderson Manufacturing warrants its manufactured products to be free from defects in material or workmanship for a period of ~~one year~~, after delivery to the original user, ~~or 18 months after factory invoice, whichever occurs first~~. This warranty of our products under normal use and service is limited to replacement and repair, at the company's factory, of any parts which are returned to the factory freight prepaid, and after our examination were found to be defective.

B. EXCLUSIONS:

1. This warranty is expressly limited to parts replacement and repair, and is not transferable. Any expressed warranty not herein provided, and any remedy for breach of contract is excluded and disclaimed. The implied warranties of merchantability and of fitness for any particular purpose are limited to ~~one year~~ from delivery to the original user, ~~or 18 months from factory invoice~~ ~~whichever occurs first~~. ← two years
2. Any component or part manufactured by others will carry that manufacturer's warranty, and in no case will Henderson Manufacturing be liable, either expressed or implied, for warranties in excess of those made by the original manufacturer.
3. Under no circumstances will Henderson Manufacturing be liable to the purchaser, or any other person, for any incidental or consequential damages. The user assumes liability for all personal injury or property damage resulting from the handling, possession, or use of the product.
4. Repairs or modifications done by others, or parts from other sources outside the company's factory are not covered by this warranty.
5. No agent, employee, or representative of Henderson Manufacturing has any authority to make any affirmation, representation, or warranty concerning Henderson Manufacturing products, except as specifically stated above.

WARRANTY PROCEDURE

1. Prior authorization by Henderson Manufacturing, must be obtained for all warranty work.
2. Contact our distributor or Henderson Manufacturing giving complete details of your request, the unit involved, including serial number, date purchased, who purchased from, and the nature of or reason for the claim.
3. A Warranty Request Number will be assigned, and is required, whenever any warranty is to be paid either in the form of cash, credit, replacement of parts, or service work.
4. The assignment of a Warranty Request Number does not guarantee warranty will be allowed. The number is to identify the request and part to be returned.
5. When parts are shipped on a Warranty Request, you may be required to return defective part(s) for inspection by Henderson Mfg. or the original manufacturer. In this case, you will be invoiced for shipment of new components until the old unit is returned.

FEATURES AND SPECIFICATIONS

TWO MAJOR TYPES OF TRIP DESIGNS TO MEET YOUR PLOWING CONDITIONS:

1) FULL MOLDBOARD TRIP

- Twin Compression Springs
- *Adjustable Twin Compression Spring Trip
- Cannon

2) CUTTING EDGE TRIP

- One-piece adjustable torsion spring

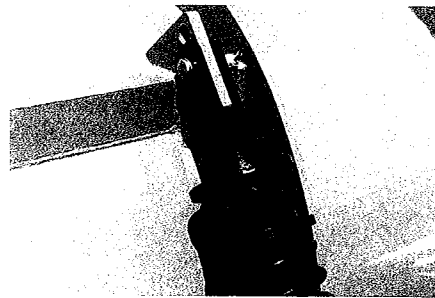

*ADJUSTABLE TRIP TENSION MOLDBOARD

The exclusive, patented, Henderson five-position compression spring settings are easily adjustable to provide variable control of trip force for all snow and ice conditions. (OPTIONAL)

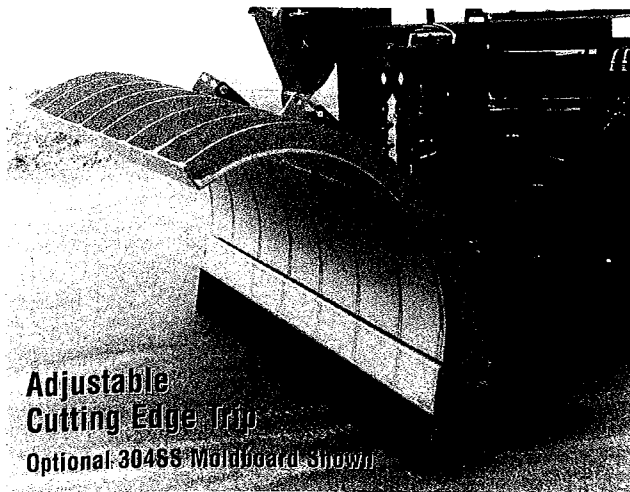

Adjustable Cutting Edge Trip
Optional 304SS Moldboard Shown

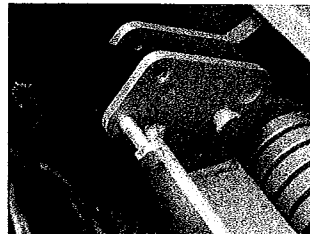
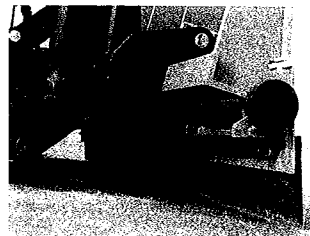

ADJUSTABLE CUTTING EDGE TRIP FEATURES

- Five 3/4" Square Torsion Springs
- Zero insertion force for easy and SAFE spring replacement
- Each spring features individual three-position trip tension adjustment, wrench included
- Cutting edge trip design allows for "smoother" trip action and minimizes shock to the truck chassis and driver

Plow Model #	Length	Height	Approx. Wt./Lbs.
RSP-10-36-FT-ST	10'	36"	1750
RSP-10-42-FT-ST	10'	42"	1760
RSP-10-48-FT-ST	10'	48"	1790
RSP-11-36-FT-ST	11'	36"	1815
RSP-11-42-FT-ST	11'	42"	1830
RSP-11-48-FT-ST	11'	48"	1860
RSP-12-36-FT-ST	12'	36"	1875
RSP-12-42-FT-ST	12'	42"	1890
RSP-12-48-FT-ST	12'	48"	1925

CUTTING PATH

Cutting path at 35° for a 10' length is 8'2"
Cutting path at 35° for a 11' length is 9'0"
Cutting path at 35° for a 12' length is 9'10"

MOLDBOARD

- "Level lift" design allows the plow to remain level with road in any position when using Henderson Hitch
- 10GA Grade 50 rolled moldboard with 1/2" x 3-1/2" rolled ribs
- Continuous welded one-piece moldboard
- Reinforced 4" x 4" x 3/4" bottom angle
- 3-1/2" x 2-1/2" x 3/8" top angle with holes to allow moisture to escape
- Two horizontal braces for added rigidity
- Attack angle is adjustable to 5°, 10° and 20°
- 5/8" x 8" one-piece cutting edge with AASHO punching is standard

PUSH FRAME

- Push frame width is 96"
- Semi-circle is 3-1/2" x 3-1/2" x 1/2" angle welded to 4" x 4" x 3/8" structural tube
- Five moldboard-to-push frame pivot points with 1-1/4" bushings pin to two 5/8" mounting ears (Six pivot points on adjustable cutting edge trip)

AVAILABLE OPTIONS

- Rectangular Wear Shoes, Carbide Shoes, Mushroom Shoes, 8" and 10" Caster Wheels, Pneumatic Wheels, Moldboard Shoes
- Curb Bumper
- Wraparound Curb Guard
- Rubber Deflector
- Sight Markers
- Carbide Cutting Edge
- Rubber Cutting Edge
- Polymer Moldboard
- 3/16" Moldboard

- 3 x 2 x 10 Lift/Reversing Cylinder
- 4 x 2 x 10 Lift/Reversing Cylinder
- Integral shield extends a minimum of 19" beyond cutting edge

OPTIONAL 304SS MOLDBOARD SHEET

- More corrosion resistant
- Higher brinell hardness increases wear resistance
- 304SS has lower friction coefficient and allows snow to flow smoothly

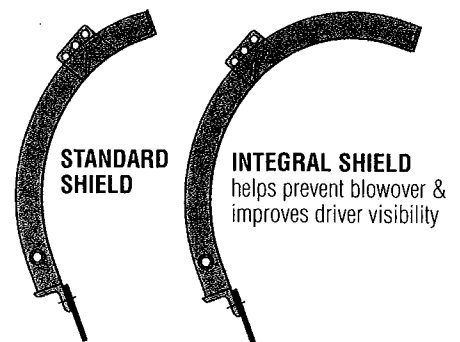

STANDARD SHIELD

INTEGRAL SHIELD helps prevent blowover & improves driver visibility



P.O. Box 40 • Manchester, Iowa 52057
800-359-4970 • www.henderson-mfg.com

BAKER TRUCK EQUIPMENT CO.

P.O. BOX 482

HURRICANE, WV 25526

PHONE: 304-722-3814

Henderson puts you in the fast lane with your snow and ice control program.

Whether it be city, rural or interstate highway snow and ice control, the Henderson SNOWFOE Series reversible plow takes an adversarial attitude toward the most demanding conditions. This entry into the snow and ice control field comes with an impressive pedigree: Henderson has long been recognized as a leader in spreaders and pre-wetting equipment, and the Mark Series of dump bodies is legendary.

Designed from the ground up, the Henderson SNOWFOE Series reversible plows are state-of-the-art. They're designed to manhandle snow and ice and to last longer while they're doing it.

Many innovative features have been engineered into the SNOWFOE Series to provide you with a plow that moves snow and ice cleaner and quicker because its unique moldboard curvature rolls material out of the way smoothly and almost effortlessly. It is virtually self-cleaning with less chance for back-up and reduced drift to obscure driver vision.

Yet, they are priced to help you stay within budget on your initial purchase...and their ruggedness will surely serve you for years to come.

Once again, you can rely on...

The Dependable Ones

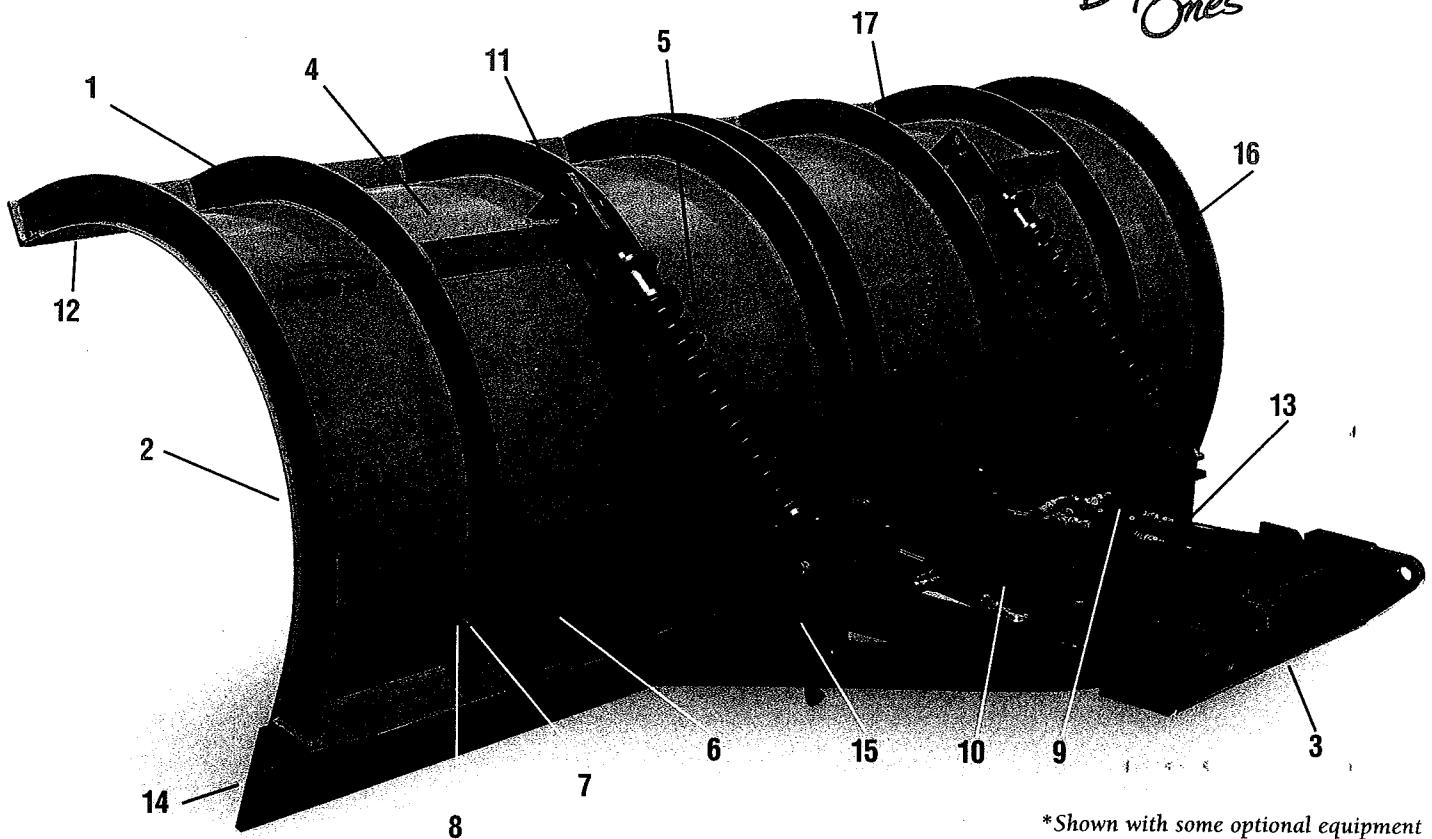

*Shown with some optional equipment

- 1 Eight 1/2" x 3 1/2" edge-rolled ribs for extra strength and rigidity.
- 2 Moldboard curvature designed to improve snow moving capabilities while minimizing "drift."
- 3 Supported by the Henderson Hitch, the plow, in any position, remains level to the road.
- 4 One-piece moldboard is rolled instead of break-formed presenting a smooth, clean surface for better material flow.
- 5 Two easily adjustable compression springs have five position settings for variable control of the trip force. (Optional)
- 6 Extended push tube (14% longer than other makes) gives greater blade stability.

- 7 Five moldboard-to-push frame pivot points more evenly distribute push force throughout the entire plow. (Six pivot points on adjustable cutting edge trip).
- 8 1-1/4" bushings are welded through ribs to provide greater pivot pin bearing surface and enhanced durability.
- 9 Plow-mounted cushion valve is standard.
- 10 Twin reversing cylinders are located above the push frame for protection against road debris.
- 11 Three-position attack angle adjustment (5°, 10°, 20° approx.) to meet all snow and ice removal conditions.
- 12 Moldboard height measures from the road surface to inside of arc - not top of ribs as with some manufacturers.

- 13 Twin 3" x 10" nitrided hydraulic cylinders are double-acting for heavy-duty power reversing.
- 14 One-piece 5/8" x 8" cutting edge gives extended wear.
- 15 Trip-spring anchor plates are encased and continuous welded to the push frame providing greater strength.
- 16 All parts are continuously welded which minimizes corrosion points.
- 17 All surfaces are high pressure cleaned and degreased with phosphate solution before powder coat Highway orange paint. Push frame assembly and hitch components are powder coat painted black.

State of West Virginia

VENDOR PREFERENCE CERTIFICATE

Certification and application* is hereby made for Preference in accordance with West Virginia Code, §5A-3-37. (Does not apply to construction contracts). West Virginia Code, §5A-3-37, provides an opportunity for qualifying vendors to request (at the time of bid) preference for their residency status. Such preference is an evaluation-method only and will be applied only to the cost bid in accordance with the West Virginia Code. This certificate for application is to be used to request such preference. The Purchasing Division will make the determination of the Resident Vendor Preference, if applicable.

- 1. Application is made for 2.5% resident vendor preference for the reason checked: Bidder is an individual resident vendor and has resided continuously in West Virginia for four (4) years immediately preceding the date of this certification; or, X Bidder is a partnership, association or corporation resident vendor and has maintained its headquarters or principal place of business continuously in West Virginia for four (4) years immediately preceding the date of this certification; or 80% of the ownership interest of Bidder is held by another individual, partnership, association or corporation resident vendor who has maintained its headquarters or principal place of business continuously in West Virginia for four (4) years immediately preceding the date of this certification; or, Bidder is a nonresident vendor which has an affiliate or subsidiary which employs a minimum of one hundred state residents and which has maintained its headquarters or principal place of business within West Virginia continuously for the four (4) years immediately preceding the date of this certification; or,
2. Application is made for 2.5% resident vendor preference for the reason checked: X Bidder is a resident vendor who certifies that, during the life of the contract, on average at least 75% of the employees working on the project being bid are residents of West Virginia who have resided in the state continuously for the two years immediately preceding submission of this bid; or,
3. Application is made for 2.5% resident vendor preference for the reason checked: Bidder is a nonresident vendor employing a minimum of one hundred state residents or is a nonresident vendor with an affiliate or subsidiary which maintains its headquarters or principal place of business within West Virginia employing a minimum of one hundred state residents who certifies that, during the life of the contract, on average at least 75% of the employees or Bidder's affiliate's or subsidiary's employees are residents of West Virginia who have resided in the state continuously for the two years immediately preceding submission of this bid; or,
4. Application is made for 5% resident vendor preference for the reason checked: X Bidder meets either the requirement of both subdivisions (1) and (2) or subdivision (1) and (3) as stated above; or,
5. Application is made for 3.5% resident vendor preference who is a veteran for the reason checked: Bidder is an individual resident vendor who is a veteran of the United States armed forces, the reserves or the National Guard and has resided in West Virginia continuously for the four years immediately preceding the date on which the bid is submitted; or,
6. Application is made for 3.5% resident vendor preference who is a veteran for the reason checked: Bidder is a resident vendor who is a veteran of the United States armed forces, the reserves or the National Guard, if, for purposes of producing or distributing the commodities or completing the project which is the subject of the vendor's bid and continuously over the entire term of the project, on average at least seventy-five percent of the vendor's employees are residents of West Virginia who have resided in the state continuously for the two immediately preceding years.

Bidder understands if the Secretary of Revenue determines that a Bidder receiving preference has failed to continue to meet the requirements for such preference, the Secretary may order the Director of Purchasing to: (a) reject the bid; or (b) assess a penalty against such Bidder in an amount not to exceed 5% of the bid amount and that such penalty will be paid to the contracting agency or deducted from any unpaid balance on the contract or purchase order.

By submission of this certificate, Bidder agrees to disclose any reasonably requested information to the Purchasing Division and authorizes the Department of Revenue to disclose to the Director of Purchasing appropriate information verifying that Bidder has paid the required business taxes, provided that such information does not contain the amounts of taxes paid nor any other information deemed by the Tax Commissioner to be confidential.

Under penalty of law for false swearing (West Virginia Code, §61-5-3), Bidder hereby certifies that this certificate is true and accurate in all respects; and that if a contract is issued to Bidder and if anything contained within this certificate changes during the term of the contract, Bidder will notify the Purchasing Division in writing immediately.

Bidder: BAKER TRUCK EQUIPMENT

Signed: [Signature]

Date: 7/19/2010

Title: SALESMAN

*Check any combination of preference consideration(s) indicated above, which you are entitled to receive.

RFQ No. 7010EC010

STATE OF WEST VIRGINIA
Purchasing Division

PURCHASING AFFIDAVIT

West Virginia Code §5A-3-10a states: No contract or renewal of any contract may be awarded by the state or any of its political subdivisions to any vendor or prospective vendor when the vendor or prospective vendor or a related party to the vendor or prospective vendor is a debtor and the debt owned is an amount greater than one thousand dollars in the aggregate

DEFINITIONS:

"Debt" means any assessment, premium, penalty, fine, tax or other amount of money owed to the state or any of its political subdivisions because of a judgment, fine, permit violation, license assessment, defaulted workers' compensation premium, penalty or other assessment presently delinquent or due and required to be paid to the state or any of its political subdivisions, including any interest or additional penalties accrued thereon.

"Debtor" means any individual, corporation, partnership, association, Limited Liability Company or any other form or business association owing a debt to the state or any of its political subdivisions. "Political subdivision" means any county commission; municipality; county board of education; any instrumentality established by a county or municipality; any separate corporation or instrumentality established by one or more counties or municipalities, as permitted by law; or any public body charged by law with the performance of a government function or whose jurisdiction is coextensive with one or more counties or municipalities. "Related party" means a party, whether an individual, corporation, partnership, association, limited liability company or any other form or business association or other entity whatsoever, related to any vendor by blood, marriage, ownership or contract through which the party has a relationship of ownership or other interest with the vendor so that the party will actually or by effect receive or control a portion of the benefit, profit or other consideration from performance of a vendor contract with the party receiving an amount that meets or exceeds five percent of the total contract amount.

EXCEPTION: The prohibition of this section does not apply where a vendor has contested any tax administered pursuant to chapter eleven of this code, workers' compensation premium, permit fee or environmental fee or assessment and the matter has not become final or where the vendor has entered into a payment plan or agreement and the vendor is not in default of any of the provisions of such plan or agreement.

Under penalty of law for false swearing (*West Virginia Code §61-5-3*), it is hereby certified that the vendor affirms and acknowledges the information in this affidavit and is in compliance with the requirements as stated.

WITNESS THE FOLLOWING SIGNATURE

Vendor's Name: Baker Truck Equipment Co.

Authorized Signature: [Signature] Date: 7-20-10

State of West Virginia

County of Putnam, to-wit:

Taken, subscribed, and sworn to before me this 20 day of July, 2010.

My Commission expires 4-2, 2017

AFFIX SEAL HERE

NOTARY PUBLIC [Signature]

