



State of West Virginia  
 Department of Administration  
 Purchasing Division  
 2019 Washington Street East  
 Post Office Box 50130  
 Charleston, WV 25305-0130

**Request for  
 Quotation**

RFQ NUMBER  
 08110010

PAGE  
 1

ADDRESS CORRESPONDENCE TO ATTENTION OF:  
 BUYER 33  
 304-558-2402

VENDOR

\*709060129 304-766-6601  
 CHARLESTON STEEL  
 PO BOX 547 511 28TH STREET  
 DUNBAR WV 25064



DIVISION OF HIGHWAYS  
 DISTRICT EIGHT  
 P.O. BOX 1516  
 US 219, NORTH PARSONS ROAD  
 ELKINS, WV  
 26241-1516 304-557-0215

W-100675

DATE PRINTED 08/02/2010	TERMS OF SALE NET 30	SHIP VIA C.C.	F.O.B. ELKINS	FREIGHT TERMS INCL
BID OPENING DATE: 08/18/2010		BID OPENING TIME 01:30PM		

LINE	QUANTITY	UCP	CAT NO	ITEM NUMBER	UNIT PRICE	AMOUNT
0001		LS		570-84		
STRUCTURAL STEEL  TO PROVIDE STRUCTURAL STEEL FOR HILE RUN BRIDGE PROJECT #S347-9-3.80 IN DISTRICT (8) EIGHT IN ELKINS, FOR THE WEST VIRGINIA DIVISION OF HIGHWAYS PER THE ATTACHED DRAWINGS AND SPECIFICATIONS.  PREFERENCE FOR USE OF DOMESTIC STEEL PRODUCTS  I. EXCEPT WHEN AUTHORIZED BY THE DIRECTOR OF THE PURCHASING DIVISION PURSUANT TO SUBSECTION 2 BELOW, NO CONTRACTOR MAY USE OR SUPPLY STEEL PRODUCTS FOR A STATE CONTRACT PROJECT OTHER THAN THOSE STEEL PRODUCTS MADE IN THE UNITED STATES. AS USED USED IN THIS CONTRACT,  A. "STATE CONTRACT PROJECT" MEANS ANY ERECTION OR CONSTRUCTION OF, OR ANY ADDITION TO, ALTERATION OF OR OTHER IMPROVEMENT TO ANY BUILDING OR STRUCTURE, INCLUDING, BUT NOT LIMITED TO, ROADS OR HIGHWAYS, OR THE INSTALLATION OF ANY HEATING OR COOLING OR VENTILATING PLANTS OR OTHER EQUIPMENT, OR THE SUPPLY OF AND MATERIALS FOR SUCH PROJECTS, PURSUANT TO A CONTRACT WITH THE STATE OF WEST VIRGINIA FOR WHICH BIDS WERE SOLICITED ON OR AFTER JUNE 6, 2001.  B. "STEEL PRODUCTS" MEANS PRODUCTS ROLLED, FORMED, SHAPED, DRAWN, EXTRUDED, FORGED, CAST, FABRICATED OR OTHERWISE SIMILARLY PROCESSED, OR PROCESSED BY A COMBINATION OF TWO OR MORE OF						

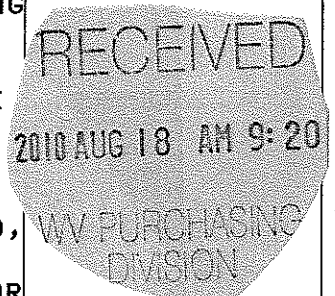

SEE REVERSE SIDE FOR TERMS AND CONDITIONS

SIGNATURE: *Dennis Nicholas* TELEPHONE: 304-766-6607 DATE: 8/17/10

TITLE: *Mgr. Purchasing Sales* FEIN: 20-5496272 ADDRESS CHANGES TO BE NOTED ABOVE

WHEN RESPONDING TO RFQ, INSERT NAME AND ADDRESS IN SPACE ABOVE LABELED 'VENDOR'

**GENERAL TERMS & CONDITIONS  
REQUEST FOR QUOTATION (RFQ) AND REQUEST FOR PROPOSAL (RFP)**

1. Awards will be made in the best interest of the State of West Virginia.
2. The State may accept or reject in part, or in whole, any bid.
3. Prior to any award, the apparent successful vendor must be properly registered with the Purchasing Division and have paid the required \$125 fee.
4. All services performed or goods delivered under State Purchase Order/Contracts are to be continued for the term of the Purchase Order/Contracts, contingent upon funds being appropriated by the Legislature or otherwise being made available. In the event funds are not appropriated or otherwise available for these services or goods this Purchase Order/Contract becomes void and of no effect after June 30.
5. Payment may only be made after the delivery and acceptance of goods or services.
6. Interest may be paid for late payment in accordance with the *West Virginia Code*.
7. Vendor preference will be granted upon written request in accordance with the *West Virginia Code*.
8. The State of West Virginia is exempt from federal and state taxes and will not pay or reimburse such taxes.
9. The Director of Purchasing may cancel any Purchase Order/Contract upon 30 days written notice to the seller.
10. The laws of the State of West Virginia and the *Legislative Rules* of the Purchasing Division shall govern the purchasing process.
11. Any reference to automatic renewal is hereby deleted. The Contract may be renewed only upon mutual written agreement of the parties.
12. **BANKRUPTCY:** In the event the vendor/contractor files for bankruptcy protection, the State may deem this contract null and void, and terminate such contract without further order.
13. **HIPAA BUSINESS ASSOCIATE ADDENDUM:** The West Virginia State Government HIPAA Business Associate Addendum (BAA), approved by the Attorney General, is available online at [www.state.wv.us/admin/purchase/vrc/hipaa.htm](http://www.state.wv.us/admin/purchase/vrc/hipaa.htm) and is hereby made part of the agreement. Provided that the Agency meets the definition of a Cover Entity (45 CFR §160.103) and will be disclosing Protected Health Information (45 CFR §160.103) to the vendor.
14. **CONFIDENTIALITY:** The vendor agrees that he or she will not disclose to anyone, directly or indirectly, any such personally identifiable information or other confidential information gained from the agency, unless the individual who is the subject of the information consents to the disclosure in writing or the disclosure is made pursuant to the agency's policies, procedures, and rules. Vendor further agrees to comply with the Confidentiality Policies and Information Security Accountability Requirements, set forth in <http://www.state.wv.us/admin/purchase/privacy/noticeConfidentiality.pdf>.
15. **LICENSING:** Vendors must be licensed and in good standing in accordance with any and all state and local laws and requirements by any state or local agency of West Virginia, including, but not limited to, the West Virginia Secretary of State's Office, the West Virginia Tax Department, and the West Virginia Insurance Commission. The vendor must provide all necessary releases to obtain information to enable the director or spending unit to verify that the vendor is licensed and in good standing with the above entities.
16. **ANTITRUST:** In submitting a bid to any agency for the State of West Virginia, the bidder offers and agrees that if the bid is accepted the bidder will convey, sell, assign or transfer to the State of West Virginia all rights, title and interest in and to all causes of action it may now or hereafter acquire under the antitrust laws of the United States and the State of West Virginia for price fixing and/or unreasonable restraints of trade relating to the particular commodities or services purchased or acquired by the State of West Virginia. Such assignment shall be made and become effective at the time the purchasing agency tenders the initial payment to the bidder.

I certify that this bid is made without prior understanding, agreement, or connection with any corporation, firm, limited liability company, partnership, or person or entity submitting a bid for the same material, supplies, equipment or services and is in all respects fair and without collusion or Fraud. I further certify that I am authorized to sign the certification on behalf of the bidder or this bid.

**INSTRUCTIONS TO BIDDERS**

1. Use the quotation forms provided by the Purchasing Division. Complete all sections of the quotation form.
2. Items offered must be in compliance with the specifications. Any deviation from the specifications must be clearly indicated by the bidder. Alternates offered by the bidder as **EQUAL** to the specifications must be clearly defined. A bidder offering an alternate should attach complete specifications and literature to the bid. The Purchasing Division may waive minor deviations to specifications.
3. Unit prices shall prevail in case of discrepancy. All quotations are considered F.O.B. destination unless alternate shipping terms are clearly identified in the quotation.
4. All quotations must be delivered by the bidder to the office listed below prior to the date and time of the bid opening. Failure of the bidder to deliver the quotations on time will result in bid disqualifications: Department of Administration, Purchasing Division, 2019 Washington Street East, P.O. Box 50130, Charleston, WV 25305-0130
5. Communication during the solicitation, bid, evaluation or award periods, except through the Purchasing Division, is strictly prohibited (W.Va. C.S.R. §148-1-6.6).



State of West Virginia  
 Department of Administration  
 Purchasing Division  
 2019 Washington Street East  
 Post Office Box 50130  
 Charleston, WV 25305-0130

# Request for Quotation

RFQ NUMBER
08110010

PAGE
2

ADDRESS CORRESPONDENCE TO ATTENTION OF
BUYER 33 304-558-2402

VENDOR

\*709060129      304-766-6601  
 CHARLESTON STEEL  
 PO BOX 547 511 28TH STREET  
 DUNBAR WV 25064

SHIP TO

DIVISION OF HIGHWAYS  
 DISTRICT EIGHT  
 P.O. BOX 1516  
 US 219, NORTH PARSONS ROAD  
 ELKINS, WV  
 26241-1516      304-557-0215

DATE PRINTED	TERMS OF SALE	SHIP VIA	F.O.B	FREIGHT TERMS
08/02/2010	NET 30	C.C.	ELKINS	INCL
BID OPENING DATE: 08/18/2010		BID OPENING TIME 01:30PM		

LINE	QUANTITY	UOP	CAT NO	ITEM NUMBER	UNIT PRICE	AMOUNT
				<p>SUCH OPERATIONS, FROM STEEL MADE BY THE OPEN HEARTH, BASIC OXYGEN, ELECTRIC FURNACE, BESSEMER OR OTHER STEEL MAKING PROCESS.</p> <p>C. "UNITED STATES" MEANS THE UNITED STATES OF AMERICA AND INCLUDES ALL TERRITORY, CONTINENTAL OR INSULAR, SUBJECT TO THE JURISDICTION OF THE UNITED STATES.</p> <p>2. THE DIRECTOR OF THE PURCHASING DIVISION MAY, IN WRITING, AUTHORIZE THE USE OF FOREIGN STEEL PRODUCTS IF:</p> <p>A. THE COST FOR EACH CONTRACT ITEM USED DOES NOT EXCEED ONE TENTH OF ONE PERCENT (.1%) OF THE TOTAL CONTRACT COST OR TWO THOUSAND FIVE HUNDRED DOLLARS (2,500.00), WHICHEVER IS GREATER. FOR THE PURPOSES OF THIS SECTION, THE COST IS THE VALUE OF THE STEEL PRODUCT AS DELIVERED TO THE PROJECT OR,</p> <p>B. THE DIRECTOR OF THE PURCHASING DIVISION DETERMINES THAT SPECIFIED STEEL MATERIALS ARE NOT PRODUCED IN THE UNITED STATES IN SUFFICIENT QUANTITY OR OTHERWISE ARE NOT REASONABLY AVAILABLE TO MEET CONTRACT REQUIREMENTS.</p> <p>3. A CONTRACTOR WHO USES STEEL PRODUCTS IN VIOLATION OF THIS SECTION MAY BE SUBJECT TO CIVIL PENALTIES PURSUANT TO WV CODE SECTION 5A-3-56.</p> <p>REV. 10/01/01</p> <p>EXHIBIT 10</p>		

SEE REVERSE SIDE FOR TERMS AND CONDITIONS

SIGNATURE <i>Dennis Nicholas</i>	TELEPHONE 304-766-6601	DATE 8/17/10
UFA# <i>Major Warehouse Sale</i>	FEIN 20-5496272	ADDRESS CHANGES TO BE NOTED ABOVE

WHEN RESPONDING TO RFQ, INSERT NAME AND ADDRESS IN SPACE ABOVE LABELED 'VENDOR'



State of West Virginia  
 Department of Administration  
 Purchasing Division  
 2019 Washington Street East  
 Post Office Box 50130  
 Charleston, WV 25305-0130

# Request for Quotation

RFQ NUMBER  
**08110010**

PAGE  
**3**

ADDRESS CORRESPONDENCE TO ATTENTION OF  
**BUYER 33**  
**304-558-2402**

PURCHASER

\*709060129      304-766-6601  
**CHARLESTON STEEL**  
**PO BOX 547 511 28TH STREET**  
  
**DUNBAR WV 25064**

SHIP TO

**DIVISION OF HIGHWAYS**  
**DISTRICT EIGHT**  
**P.O. BOX 1516**  
**US 219, NORTH PARSONS ROAD**  
**ELKINS, WV**  
**26241-1516      304-557-0215**

DATE PRINTED <b>08/02/2010</b>	TERMS OF SALE <b>NET 30</b>	SHIP VIA <b>C.O.</b>	F.O.B <b>ELKINS</b>	FREIGHT TERMS <b>INCL</b>
BID OPENING DATE: <b>08/18/2010</b>		BID OPENING TIME <b>01:30PM</b>		

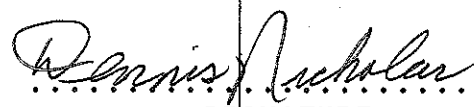
LINE	QUANTITY	UOP	CAT NO	ITEM NUMBER	UNIT PRICE	AMOUNT
REQUISITION NO.: .08110010..						
ADDENDUM ACKNOWLEDGEMENT						
I HEREBY ACKNOWLEDGE RECEIPT OF THE FOLLOWING CHECKED ADDENDUM(S) AND HAVE MADE THE NECESSARY REVISIONS TO MY PROPOSAL, PLANS AND/OR SPECIFICATION, ETC.						
ADDENDUM NO.'S:						
NO. 1 .....						
NO. 2 .....						
NO. 3 .....						
NO. 4 .....						
NO. 5 .....						
I UNDERSTAND THAT FAILURE TO CONFIRM THE RECEIPT OF THE ADDENDUM(S) MAY BE CAUSE FOR REJECTION OF BIDS.						
VENDOR MUST CLEARLY UNDERSTAND THAT ANY VERBAL REPRESENTATION MADE OR ASSUMED TO BE MADE DURING ANY ORAL DISCUSSION HELD BETWEEN VENDOR'S REPRESENTATIVES AND ANY STATE PERSONNEL IS NOT BINDING. ONLY THE INFORMATION ISSUED IN WRITING AND ADDED TO THE SPECIFICATIONS BY AN OFFICIAL ADDENDUM IS BINDING.						
 ..... SIGNATURE <b>DENNIS NICHOLAS</b> .....						

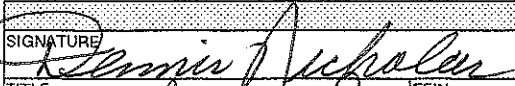
SEE REVERSE SIDE FOR TERMS AND CONDITIONS			
SIGNATURE 	TELEPHONE <b>304-766-6607</b>	DATE <b>8/17/10</b>	
TITLE <b>Mgr. Warehouse Sale</b>	FEIN <b>70-5496272</b>	ADDRESS CHANGES TO BE NOTED ABOVE	

WHEN RESPONDING TO RFQ, INSERT NAME AND ADDRESS IN SPACE ABOVE LABELED 'VENDOR'



State of West Virginia  
 Department of Administration  
 Purchasing Division  
 2019 Washington Street East  
 Post Office Box 50130  
 Charleston, WV 25305-0130

# Request for Quotation

RFQ NUMBER  
**08110010**

PAGE  
**4**

ADDRESS CORRESPONDENCE TO ATTENTION OF  
**BUYER 33**  
**304-558-2402**

**\*709060129 304-766-6601**  
**CHARLESTON STEEL**  
**PO BOX 547 511 28TH STREET**  
**DUNBAR WV 25064**

**DIVISION OF HIGHWAYS**  
**DISTRICT EIGHT**  
**P.O. BOX 1516**  
**US 219, NORTH PARSONS ROAD**  
**ELKINS, WV**  
**26241-1516 304-557-0215**

DATE PRINTED <b>08/02/2010</b>	TERMS OF SALE <b>NET 30</b>	SHIP VIA <b>C.C.</b>	F.O.B. <b>ELKINS</b>	FREIGHT TERMS <b>INC</b>
BID OPENING DATE: <b>08/18/2010</b>		BID OPENING TIME <b>01:30PM</b>		

LINE	QUANTITY	UOP	CAT NO	ITEM NUMBER	UNIT PRICE	AMOUNT
COMPANY <b>..... CHARLESTON STEEL</b> DATE <b>8/17/10</b>						
NOTE: THIS ADDENDUM ACKNOWLEDGEMENT SHOULD BE SUBMITTED WITH THE BID. REV. 09/21/2009 NOTICE A SIGNED BID MUST BE SUBMITTED TO: DEPARTMENT OF ADMINISTRATION PURCHASING DIVISION BUILDING 15 2019 WASHINGTON STREET, EAST CHARLESTON, WV 25305-0130 THE BID SHOULD CONTAIN THIS INFORMATION ON THE FACE OF THE ENVELOPE OR THE BID MAY NOT BE CONSIDERED: SEALED BID BUYER: <b>33</b> RFQ. NO.: <b>08110010</b> BID OPENING DATE: <b>08/18/2010</b> BID OPENING TIME: <b>1:30 PM</b>						

SEE REVERSE SIDE FOR TERMS AND CONDITIONS

SIGNATURE <i>Wendell Scholten</i>	TELEPHONE <b>304-766-6607</b>	DATE <b>8/17/10</b>
TITLE <i>Mgr. Warehouse Sale</i>	FEIN <b>20-5496272</b>	ADDRESS CHANGES TO BE NOTED ABOVE

WHEN RESPONDING TO RFQ, INSERT NAME AND ADDRESS IN SPACE ABOVE LABELED 'VENDOR'



State of West Virginia  
 Department of Administration  
 Purchasing Division  
 2019 Washington Street East  
 Post Office Box 50130  
 Charleston, WV 25305-0130

# Request for Quotation

RFQ NUMBER  
**08110010**

PAGE  
**5**

ADDRESS CORRESPONDENCE TO ATTENTION OF  
**BUYER 33**  
**304-558-2402**

VENDOR

\*709060129      304-766-6601  
 CHARLESTON STEEL  
 PO BOX 547 511 28TH STREET  
 DUNBAR WV 25064

SHIP TO

DIVISION OF HIGHWAYS  
 DISTRICT EIGHT  
 P.O. BOX 1516  
 US 219, NORTH PARSONS ROAD  
 ELKINS, WV  
 26241-1516      304-557-0215

DATE PRINTED <b>08/02/2010</b>	TERMS OF SALE <b>NET 30</b>	SHIP VIA <b>C.C.</b>	F.O.B. <b>ELKINS</b>	FREIGHT TERMS <b>INCL</b>
BID OPENING DATE: <b>08/18/2010</b>		BID OPENING TIME <b>01:30PM</b>		

LINE	QUANTITY	UOP	CAT. NO.	ITEM NUMBER	UNIT PRICE	AMOUNT
PLEASE PROVIDE A FAX NUMBER IN CASE IT IS NECESSARY TO CONTACT YOU REGARDING YOUR BID: ----- <b>304-766-6603</b> -----  CONTACT PERSON (PLEASE PRINT CLEARLY): ----- <b>DENNIS NICHOLAS</b> -----						
***** THIS IS THE END OF RFQ 08110010 *****						<b>TOTAL: \$34,774.29</b>

SEE REVERSE SIDE FOR TERMS AND CONDITIONS

SIGNATURE <i>Dennis Nicholas</i>	TELEPHONE <b>304-766-6601</b>	DATE <b>8/17/10</b>
TITLE <i>Mgr. Warehouse</i>	FEIN <b>20-5496272</b>	ADDRESS CHANGES TO BE NOTED ABOVE

WHEN RESPONDING TO RFQ, INSERT NAME AND ADDRESS IN SPACE ABOVE LABELED 'VENDOR'

Item No.	Quantity	Description	Unit Price	Amount
1	19,285 lbs	W24x76, Galvanized W-Shaped Structural Steel, AASHTO M270, Grade 50.  Ship: 6 pcs. @ 42'- 3½" fabricated in accordance with Sketch # 1.	<u>\$1.07</u>	<u>\$ 20,634.95</u>
2	2,000 lbs.	C12x25, Galvanized Structural Steel Channel, AASHTO M270, Grade 50.  Ship: 4 pcs @ 20'- 0"	<u>\$ 1.28</u>	<u>\$ 2,560.00</u>
3	972 lbs.	L 6" x 4" x 1/2" (16.2 #/LF) Galvanized Structural Steel Angle, AASHTO M270, Grade 50.  Ship: 3 pcs. @ 20'- 0"	<u>\$1.15</u>	<u>\$ 1,117.80</u>
4	922 lbs.	L 4" x 4" x 1/2" (12.8 #/LF) Galvanized Structural Steel Angle, AASHTO M270, Grade 50.  Ship: 72 pcs @ 1' -0" fabricated in accordance with Sketch # 2	<u>\$ 1.40</u>	<u>\$ 1,290.80</u>
5	2,114 lbs.	6" x 6" x 1/2" Galvanized Structural Steel Tubing (35.24 #/LF) ASTM A500.  Ship: 3 pcs. @ 20'- 0"	<u>\$ 0.80</u>	<u>\$ 1,691.20</u>
6	143 lbs.	7/8" x 6" Galvanized Structural Steel Bar (17.9 #/LF), AASHTO M270, Grade 50.  Ship: 3 pcs. @ 2'- 8" fabricated in accordance with Mark P1 on Sketch # 3.	<u>\$3.35</u>	<u>\$ 479.05</u>
7	918 lbs.	3/4" x 6" Galvanized Structural Steel Bar (15.3 #/LF) AASHTO M270, Grade 50.  Ship: 3 pcs. @ 20'- 0"	<u>\$1.16</u>	<u>\$1,064.88</u>
8	157 lbs.	3/4" x 6" Galvanized Structural Steel Bar (15.3 #/LF) AASHTO M270, Grade 50.  Ship: 3 pcs. @ 3'- 5" fabricated in accordance with Mark P2 on Sketch # 3.	<u>\$1.73</u>	<u>\$ 271.61</u>

Item No.	Quantity	Description	Unit Price	Amount
9	3,600 lbs.	HP8x36, Galvanized HP-Shaped Structural Steel Channel, AASHTO M270, Grade 50. Ship: 5 pcs @ 20'- 0"	<u>#.92</u>	<u>\$3,312.00</u>
10	1,600 lbs.	W6x16, Galvanized W-Shaped Structural Steel Channel, AASHTO M270, Grade 50. Ship: 5 pcs @ 20'- 0"	<u>#1.47</u>	<u>\$2,352.00</u>
<b>TOTAL</b>				<u>\$34,774.29</u>
<ol style="list-style-type: none"> <li>1. The above listed materials are to be delivered to the WVDOH, District Eight lot, located on US Route 219, approximately 1 mile north of Elkins WV.</li> <li>2. The District Eight Storekeeper must be notified at (304) 637-0226 at least 48 hours in advance of delivery to provide necessary personnel and equipment for unloading.</li> <li>3. Delivery will only be accepted during normal working hours of 7:30am to 4:00pm, Monday - Friday.</li> <li>4. All galvanizing shall be in accordance with AASHTO M111.</li> <li>5. Steel designated as AASHTO M270 shall conform to Section S4. Non-Fracture-Critical, Zone 2, toughness testing and requirements.</li> <li>6. The project is scheduled for November, 2010.</li> </ol>				



W. Va. Dept. of Transportation—Division of Highways  
District 8; PO Box 1516  
Elkins, WV 26241

PO No. 0811-0010  
Page No. 5 of 7  
Sketch No. 1

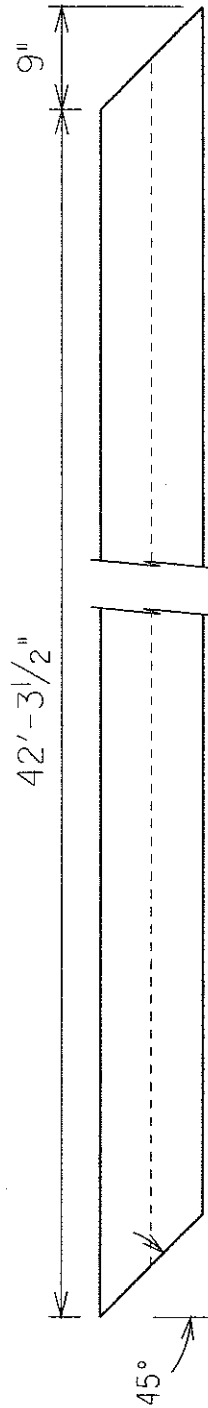

GALVANIZED W24x76 W-BEAM  
(6- Required)

W. Va. Department of Transportation  
Division of Highways, District 8  
PO Box 1516  
Elkins, WV 26241  
RPO No. 0811-0010  
Page No. 6 of 7  
Sketch No. 2

ALL HOLES  $1\frac{3}{16}$ " DIAMETER

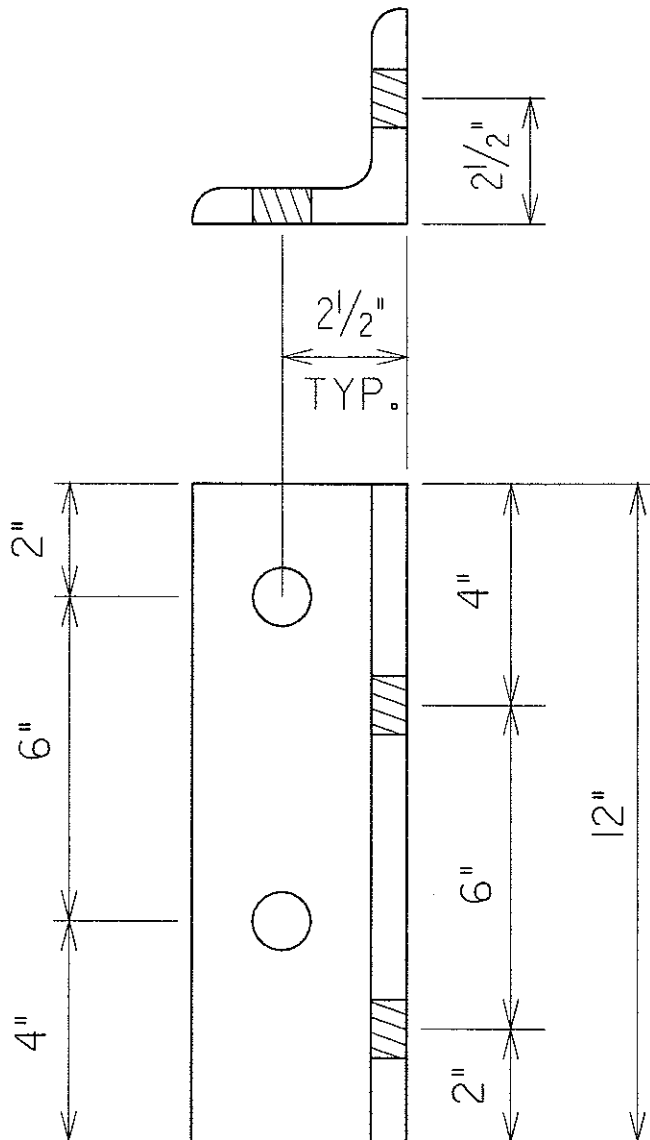

GALVANIZED CLIP ANGLE

ANGLE  $4'' \times 4'' \times \frac{1}{2}''$  - 72 REQUIRED

W. Va. Department of Transportation—Division of Highways  
District 8, PO Box 1516, Elkins, WV 26241

PO No. 0811-0010

Page No. 7 of 7

Sketch No. 3

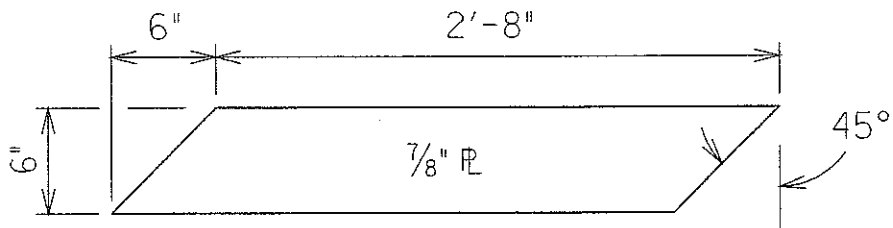

GALVANIZED  $\frac{7}{8}$ " PLATE - MARK P1  
( 3 - Required )

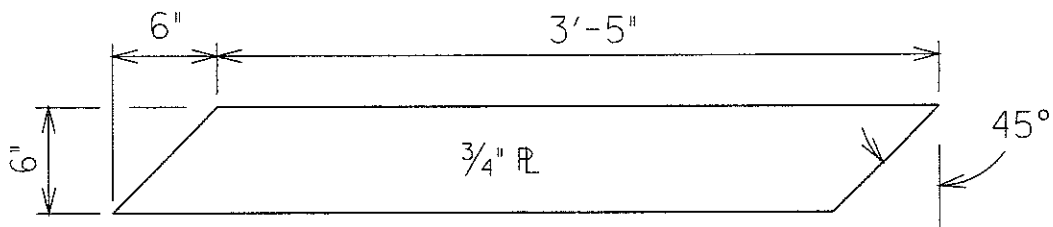

GALVANIZED  $\frac{3}{4}$ " PLATE - MARK P2  
( 3 - Required )

State of West Virginia

VENDOR PREFERENCE CERTIFICATE

Certification and application\* is hereby made for Preference in accordance with West Virginia Code, §5A-3-37. (Does not apply to construction contracts). West Virginia Code, §5A-3-37, provides an opportunity for qualifying vendors to request (at the time of bid) preference for their residency status. Such preference is an evaluation method only and will be applied only to the cost bid in accordance with the West Virginia Code. This certificate for application is to be used to request such preference. The Purchasing Division will make the determination of the Resident Vendor Preference, if applicable.

- 1. Application is made for 2.5% resident vendor preference for the reason checked: Bidder is an individual resident vendor and has resided continuously in West Virginia for four (4) years immediately preceding the date of this certification; or, Bidder is a partnership, association or corporation resident vendor and has maintained its headquarters or principal place of business continuously in West Virginia for four (4) years immediately preceding the date of this certification; or 80% of the ownership interest of Bidder is held by another individual, partnership, association or corporation resident vendor who has maintained its headquarters or principal place of business continuously in West Virginia for four (4) years immediately preceding the date of this certification; or, Bidder is a nonresident vendor which has an affiliate or subsidiary which employs a minimum of one hundred state residents and which has maintained its headquarters or principal place of business within West Virginia continuously for the four (4) years immediately preceding the date of this certification; or,
2. Application is made for 2.5% resident vendor preference for the reason checked: Bidder is a resident vendor who certifies that, during the life of the contract, on average at least 75% of the employees working on the project being bid are residents of West Virginia who have resided in the state continuously for the two years immediately preceding submission of this bid; or,
3. Application is made for 2.5% resident vendor preference for the reason checked: Bidder is a nonresident vendor employing a minimum of one hundred state residents or is a nonresident vendor with an affiliate or subsidiary which maintains its headquarters or principal place of business within West Virginia employing a minimum of one hundred state residents who certifies that, during the life of the contract, on average at least 75% of the employees or Bidder's affiliate's or subsidiary's employees are residents of West Virginia who have resided in the state continuously for the two years immediately preceding submission of this bid; or,
4. Application is made for 5% resident vendor preference for the reason checked: Bidder meets either the requirement of both subdivisions (1) and (2) or subdivision (1) and (3) as stated above; or,
5. Application is made for 3.5% resident vendor preference who is a veteran for the reason checked: Bidder is an individual resident vendor who is a veteran of the United States armed forces, the reserves or the National Guard and has resided in West Virginia continuously for the four years immediately preceding the date on which the bid is submitted; or,
6. Application is made for 3.5% resident vendor preference who is a veteran for the reason checked: Bidder is a resident vendor who is a veteran of the United States armed forces, the reserves or the National Guard, if, for purposes of producing or distributing the commodities or completing the project which is the subject of the vendor's bid and continuously over the entire term of the project, on average at least seventy-five percent of the vendor's employees are residents of West Virginia who have resided in the state continuously for the two immediately preceding years.

Bidder understands if the Secretary of Revenue determines that a Bidder receiving preference has failed to continue to meet the requirements for such preference, the Secretary may order the Director of Purchasing to: (a) reject the bid; or (b) assess a penalty against such Bidder in an amount not to exceed 5% of the bid amount and that such penalty will be paid to the contracting agency or deducted from any unpaid balance on the contract or purchase order.

By submission of this certificate, Bidder agrees to disclose any reasonably requested information to the Purchasing Division and authorizes the Department of Revenue to disclose to the Director of Purchasing appropriate information verifying that Bidder has paid the required business taxes, provided that such information does not contain the amounts of taxes paid nor any other information deemed by the Tax Commissioner to be confidential.

Under penalty of law for false swearing (West Virginia Code, §61-5-3), Bidder hereby certifies that this certificate is true and accurate in all respects; and that if a contract is issued to Bidder and if anything contained within this certificate changes during the term of the contract, Bidder will notify the Purchasing Division in writing immediately.

Bidder: Charleston Steel
Date: 8/17/16

Signed: Dennis Duchala
Title: Mgr Warehouse Sales

\*Check any combination of preference consideration(s) indicated above, which you are entitled to receive.

RFQ No. 08110010

STATE OF WEST VIRGINIA  
Purchasing Division

# PURCHASING AFFIDAVIT

**West Virginia Code §5A-3-10a states:** No contract or renewal of any contract may be awarded by the state or any of its political subdivisions to any vendor or prospective vendor when the vendor or prospective vendor or a related party to the vendor or prospective vendor is a debtor and the debt owned is an amount greater than one thousand dollars in the aggregate

**DEFINITIONS:**

"Debt" means any assessment, premium, penalty, fine, tax or other amount of money owed to the state or any of its political subdivisions because of a judgment, fine, permit violation, license assessment, defaulted workers' compensation premium, penalty or other assessment presently delinquent or due and required to be paid to the state or any of its political subdivisions, including any interest or additional penalties accrued thereon.

"Debtor" means any individual, corporation, partnership, association, Limited Liability Company or any other form or business association owing a debt to the state or any of its political subdivisions. "Political subdivision" means any county commission; municipality; county board of education; any instrumentality established by a county or municipality; any separate corporation or instrumentality established by one or more counties or municipalities, as permitted by law; or any public body charged by law with the performance of a government function or whose jurisdiction is coextensive with one or more counties or municipalities. "Related party" means a party, whether an individual, corporation, partnership, association, limited liability company or any other form or business association or other entity whatsoever, related to any vendor by blood, marriage, ownership or contract through which the party has a relationship of ownership or other interest with the vendor so that the party will actually or by effect receive or control a portion of the benefit, profit or other consideration from performance of a vendor contract with the party receiving an amount that meets or exceeds five percent of the total contract amount.

**EXCEPTION:** The prohibition of this section does not apply where a vendor has contested any tax administered pursuant to chapter eleven of this code, workers' compensation premium, permit fee or environmental fee or assessment and the matter has not become final or where the vendor has entered into a payment plan or agreement and the vendor is not in default of any of the provisions of such plan or agreement.

Under penalty of law for false swearing (*West Virginia Code §61-5-3*), it is hereby certified that the vendor affirms and acknowledges the information in this affidavit and is in compliance with the requirements as stated.

**WITNESS THE FOLLOWING SIGNATURE**

Vendor's Name: CHARLESTON STEEL

Authorized Signature: *Dennis J. [Signature]* Date: 8/17/10

State of WEST VIRGINIA

County of KANAWHA, to-wit:

Taken, subscribed, and sworn to before me this 17 day of AUGUST, 2010.

My Commission expires JANUARY 30, 2011.

AFFIX SEAL HERE

NOTARY PUBLIC

*[Signature]*

