



6444 Sissonville Dr
Sissonville, WV 25320
(304) 984-0415 FAX (304) 984-0124

William R. Sharpe Jr. Hospital Access Control System

Scope :

Provide a fully functional access control per specifications at 21 door locations. System to include 3 administrative workstation running enterprise client software via owners network. All computer hardware & software for system operation is included.

System to include :

Qty	Description
1	Schlage SMS Enterprise 5 Client License
3	Dell Vostro 220 Mini Tower XP Pro Workstations w/18.5" Flat Panel Monitors
3	Schlage SRCNX-16 Door Controllers
42	Schlage SRINX-1 Reader Interfaces
42 X1	HID 6005 Proximity Reader
650	HID MicroProx Tags (to be attached to existing photo ID's)
33	ROFU 8011-004 Delayed Egress MagLocks with Push Bar
3	Altronix AL1024 Power Supplies (Fire Alarm Interface & Battery BackUp)
1	Lot – Misc Items & Labor to complete a fully functional system

TOTAL PRICE \$83,650

Optional Integrated CCTV System

Scope :

Provide a fully integrated CCTV System that utilizes the Schlage SMS Software included in the base bid of this project. Access events, alarms and video recording are fully integrated and searchable within the same client/database system.

Quote No :
Re:
Page 2
August 19, 2009

System to include :

Qty	Description
1	Schlage SEVMS-32H2 Hybrid IP/Analog DVR 32 CH 1.5TB 480IPS
21	Nuvico CB-HD21N-L 2.8-10mm Outdoor Cameras (Day/Night with 36 IR LED's)
1	Lot -- Misc Items & Labor to complete a fully functional system

TOTAL PRICE \$29,950



State of West Virginia
 Department of Administration
 Purchasing Division
 2019 Washington Street East
 Post Office Box 50130
 Charleston, WV 25305-0130

**Request for
 Quotation**

RFP NUMBER
 WSH10002

PAGE
 1

ADDRESS CORRESPONDENCE TO ATTENTION OF
 ROBERTA WAGNER
 304-558-0067

RFQ COPY

TYPE NAME/ADDRESS HERE
 Mountain State Building Automation
 6444 Sissonville Dr
 Sissonville, WV 25320

HEALTH AND HUMAN RESOURCES
 WILLIAM R. SHARPE JR. HOSPITAL
 CENTRAL RECEIVING
 936 SHARPE HOSPITAL ROAD
 WESTON, WV
 26452 304-269-1210

DATE PRINTED	TERMS OF SALE	SHIP VIA	F.O.B.	FREIGHT TERMS
07/01/2009				

BID OPENING DATE: 08/04/2009 BID OPENING TIME 01:30PM

LINE	QUANTITY	UOP	CAT NO	ITEM NUMBER	UNIT PRICE	AMOUNT
***** MANDATORY PRE-BID MEETING IS SCHEDULED FOR JULY 15, 2009 AT 1:00 PM AT WILLIAM R. SHARPE, JR HOSPITAL, 936 SHARPE HOSPITAL ROAD, WESTON, WV 26452 NO ONE PERSON MAY REPRESENT MORE THAN ONE VENDOR. *****						
0001	1	JB		990-22		\$ 83,650
ACCESS CONTROL SECURITY SYSTEM WILLIAM R SHARPE JR HOSPITAL IS SEEKING BIDS FOR THE PURCHASE AND INSTALLATION OF AN ACCESS CONTROL SECURITY SYSTEM DESIGNED TO INCLUDE READER-IN/READER-OUT CAPABILITIES AT SEVENTEEN (17) EXTERIOR DOORS AT THE FACILITY. THE SYSTEM MUST MEET FIRE MARSHALL AND OTHER HOSPITAL REGULATIONS AND REQUIREMENTS. (SEE ATTACHED SPECIFICATIONS.) VENDOR IS IDENTIFY THE PRODUCT AND PROVIDE PRODUCT BROCHURES AS TO ABILITY TO MEET THE BID SPECIFICATIONS. A MANDATORY VENDOR PREBID CONFERENCE IS SCHEDULED FOR JULY 15, 2009 AT 1:00 PM IN THE BUSINESS OFFICE OF WILLIAM R SHARPE JR HOSPITAL, 936 SHARPE HOSPITAL ROAD, WESTON, WV 26452. INQUIRIES:						

RECEIVED
 2009 AUG 20 PM 12:24
 WV PURCHASING
 DIVISION

SEE REVERSE SIDE FOR TERMS AND CONDITIONS		
SIGNATURE <i>Ci. Cut</i>	TELEPHONE (304) 984-0415	DATE 8/19/09
TITLE Vice President	FON 26-3312652	ADDRESS CHANGES TO BE NOTED ABOVE

WHEN RESPONDING TO RFQ, INSERT NAME AND ADDRESS IN SPACE ABOVE LABELED 'VENDOR'

**GENERAL TERMS & CONDITIONS
REQUEST FOR QUOTATION (RFQ) AND REQUEST FOR PROPOSAL (RFP)**

1. Awards will be made in the best interest of the State of West Virginia
2. The State may accept or reject in part, or in whole, any bid
3. All quotations are governed by the *West Virginia Code* and the *Legislative Rules* of the Purchasing Division
4. Prior to any award, the apparent successful vendor must be properly registered with the Purchasing Division and have paid the required \$125 fee
5. All services performed or goods delivered under State Purchase Order/Contracts are to be continued for the term of the Purchase Order/Contracts, contingent upon funds being appropriated by the Legislature or otherwise being made available. In the event funds are not appropriated or otherwise available for these services or goods, this Purchase Order/Contract becomes void and of no effect after June 30
6. Payment may only be made after the delivery and acceptance of goods or services
7. Interest may be paid for late payment in accordance with the *West Virginia Code*
8. Vendor preference will be granted upon written request in accordance with the *West Virginia Code*
9. The State of West Virginia is exempt from federal and state taxes and will not pay or reimburse such taxes
10. The Director of Purchasing may cancel any Purchase Order/Contract upon 30 days written notice to the seller.
11. The laws of the State of West Virginia and the *Legislative Rules* of the Purchasing Division shall govern all rights and duties under the Contract, including without limitation the validity of this Purchase Order/Contract
12. Any reference to automatic renewal is hereby deleted. The Contract may be renewed only upon mutual written agreement of the parties
13. **BANKRUPTCY:** In the event the vendor/contractor files for bankruptcy protection, the State may deem this contract null and void, and terminate such contract without further order
14. **HIPAA BUSINESS ASSOCIATE ADDENDUM:** The West Virginia State Government HIPAA Business Associate Addendum (BAA), approved by the Attorney General, and available online at the Purchasing Division's web site (<http://www.state.wv.us/admin/purchase/vrc/hipaa.htm>) is hereby made part of the agreement. Provided that, the Agency meets the definition of a Cover Entity (45 CFR §160 103) and will be disclosing Protected Health Information (45 CFR §160 103) to the vendor
15. **WEST VIRGINIA ALCOHOL & DRUG-FREE WORKPLACE ACT:** If this Contract constitutes a public improvement construction contract as set forth in Article 1D, Chapter 21 of the West Virginia Code ("The West Virginia Alcohol and Drug-Free Workplace Act"), then the following language shall hereby become part of this Contract: "The contractor and its subcontractors shall implement and maintain a written drug-free workplace policy in compliance with the West Virginia Alcohol and Drug-Free Workplace Act, as set forth in Article 1D, Chapter 21 of the West Virginia Code. The contractor and its subcontractors shall provide a sworn statement in writing, under the penalties of perjury, that they maintain a valid drug-free work place policy in compliance with the West Virginia and Drug-Free Workplace Act. It is understood and agreed that this Contract shall be cancelled by the awarding authority if the Contractor: 1) Fails to implement its drug-free workplace policy; 2) Fails to provide information regarding implementation of the contractor's drug-free workplace policy at the request of the public authority; or 3) Provides to the public authority false information regarding the contractor's drug-free workplace policy."

INSTRUCTIONS TO BIDDERS

1. Use the quotation forms provided by the Purchasing Division
2. **SPECIFICATIONS:** Items offered must be in compliance with the specifications. Any deviation from the specifications must be clearly indicated by the bidder. Alternates offered by the bidder as **EQUAL** to the specifications must be clearly defined. A bidder offering an alternate should attach complete specifications and literature to the bid. The Purchasing Division may waive minor deviations to specifications
3. Complete all sections of the quotation form.
4. Unit prices shall prevail in case of discrepancy.
5. All quotations are considered F O B destination unless alternate shipping terms are clearly identified in the quotation
6. **BID SUBMISSION:** All quotations must be delivered by the bidder to the office listed below prior to the date and time of the bid opening. Failure of the bidder to deliver the quotations on time will result in bid disqualifications: Department of Administration, Purchasing Division, 2019 Washington Street East, P.O. Box 50130, Charleston, WV 25305-0130



State of West Virginia
 Department of Administration
 Purchasing Division
 2019 Washington Street East
 Post Office Box 50130
 Charleston, WV 25305-0130

Request for Quotation

RFQ NUMBER
WSH10002

PAGE
2

ADDRESS CORRESPONDENCE TO ATTENTION OF:
ROBERTA WAGNER 304-558-0067

RFQ COPY

TYPE NAME/ADDRESS HERE

Mountain State Building Automation
 6444 Sissonville Dr
 Sissonville, WV 25320

HEALTH AND HUMAN RESOURCES
 WILLIAM R. SHARPE JR. HOSPITAL
 CENTRAL RECEIVING
 936 SHARPE HOSPITAL ROAD
 WESTON, WV 26452
 304-269-1210

DATE PRINTED	TERMS OF SALE	SHIP VIA	F.O.B.	FREIGHT TERMS
07/01/2009				

BID OPENING DATE: 08/04/2009 BID OPENING TIME 01:30PM

LINE	QUANTITY	UOP	CAT NO	ITEM NUMBER	UNIT PRICE	AMOUNT
<p>WRITTEN QUESTIONS SHALL BE ACCEPTED THROUGH CLOSE OF BUSINESS ON 7/16/2009. QUESTIONS MAY BE SENT VIA USPS, FAX, COURIER OR E-MAIL. IN ORDER TO ASSURE NO VENDOR RECEIVES AN UNFAIR ADVANTAGE, NO SUBSTANTIVE QUESTIONS WILL BE ANSWERED ORALLY. IF POSSIBLE, E-MAIL QUESTIONS ARE PREFERRED. ADDRESS INQUIRIES TO:</p> <p>ROBERTA WAGNER DEPARTMENT OF ADMINISTRATION PURCHASING DIVISION 2019 WASHINGTON STREET, EAST CHARLESTON, WV 25311</p> <p>FAX: 304-558-4115 E-MAIL: ROBERTA.A.WAGNER@WV.GOV</p> <p>NOTICE TO PROCEED: THIS CONTRACT IS TO BE PERFORMED WITHIN 120 CALENDAR DAYS AFTER THE NOTICE TO PROCEED IS RECEIVED.</p> <p>CANCELLATION: THE DIRECTOR OF PURCHASING RESERVES THE RIGHT TO CANCEL THIS CONTRACT IMMEDIATELY UPON WRITTEN NOTICE TO THE VENDOR IF THE MATERIALS OR WORKMANSHIP SUPPLIED ARE OF AN INFERIOR QUALITY OR DO NOT CONFORM WITH THE SPECIFICATIONS OF THE BID AND CONTRACT HERE IN.</p> <p>WAGE RATES: THE CONTRACTOR OR SUBCONTRACTOR SHALL PAY THE HIGHER OF THE U.S. DEPARTMENT OF LABOR MINIMUM WAG</p>						

SIGNATURE <i>Roberta Wagner</i>		TELEPHONE (304) 984-0415	DATE 8/19/09
TITLE Vice President	FBN 26-3312652	ADDRESS CHANGES TO BE NOTED ABOVE	

WHEN RESPONDING TO RFQ, INSERT NAME AND ADDRESS IN SPACE ABOVE LABELED 'VENDOR'



State of West Virginia
 Department of Administration
 Purchasing Division
 2019 Washington Street East
 Post Office Box 50130
 Charleston, WV 25305-0130

Request for Quotation

RFQ NUMBER
 WSH10002

PAGE
 3

ADDRESS CORRESPONDENCE TO ATTENTION OF:
 ROBERTA WAGNER
 304-558-0067

RFQ COPY

TYPE NAME/ADDRESS HERE

Mountain State Building Automation
 6444 Sissonville Dr
 Sissonville, WV 25320

HEALTH AND HUMAN RESOURCES
 WILLIAM R. SHARPE JR. HOSPITAL
 CENTRAL RECEIVING
 936 SHARPE HOSPITAL ROAD
 WESTON, WV 26452
 304-269-1210

DATE PRINTED	TERMS OF SALE	SHIP VIA	F.O.B.	FREIGHT TERMS
--------------	---------------	----------	--------	---------------

07/01/2009

BID OPENING DATE: 08/04/2009 BID OPENING TIME 01:30PM

LINE	QUANTITY	UOP	CAT NO	ITEM NUMBER	UNIT PRICE	AMOUNT
------	----------	-----	--------	-------------	------------	--------

RATES AS ESTABLISHED FOR LEWIS COUNTY, PURSUANT TO WEST VIRGINIA CODE 21-5A, ET, SEQ (PREVAILING WAGE RATES APPLY TO THIS PROJECT)

WORKERS' COMPENSATION: VENDOR IS REQUIRED TO PROVIDE A CERTIFICATE FROM WORKERS' COMPENSATION IF SUCCESSFUL.

ALL OF THE ITEMS CHECKED BELOW WILL BE A REQUIREMENT OF THIS CONTRACT:

(XX) INSURANCE: SUCCESSFUL VENDOR SHALL FURNISH PROOF OF COMMERCIAL GENERAL LIABILITY INSURANCE PRIOR TO ISSUANCE OF CONTRACT. UNLESS OTHERWISE SPECIFIED IN THE BID DOCUMENTS, THE MINIMUM AMOUNT OF INSURANCE COVERAGE REQUIRED IS \$250,000

CONTRACTORS LICENSE

BIDDER TO COMPLETE:

CONTRACTORS NAME: Mountain State Building Automation

CONTRACTORS LICENSE NO.: WV 044802

THE SUCCESSFUL BIDDER WILL BE REQUIRED TO FURNISH A COPY OF THEIR CONTRACTORS LICENSE PRIOR TO ISSUANCE OF A PURCHASE ORDER/CONTRACT

APPLICABLE LAW

THE WEST VIRGINIA STATE CODE, PURCHASING DIVISION RULES AND REGULATIONS, AND THE INFORMATION PROVIDED IN THE "REQUEST FOR QUOTATION" ISSUED BY THE PURCHASING

SEE REVERSE SIDE FOR TERMS AND CONDITIONS

SIGNATURE	TELEPHONE (304) 984-0415	DATE 8/19/09
TITLE Vice President	FEIN 26-3312652	ADDRESS CHANGES TO BE NOTED ABOVE

WHEN RESPONDING TO RFQ, INSERT NAME AND ADDRESS IN SPACE ABOVE LABELED 'VENDOR'



State of West Virginia
 Department of Administration
 Purchasing Division
 2019 Washington Street East
 Post Office Box 50130
 Charleston, WV 25305-0130

Request for Quotation

RFQ NUMBER
 WSH10002

PAGE
 4

ADDRESS CORRESPONDENCE TO ATTENTION OF
 ROBERTA WAGNER
 304-558-0067

SUPPLIER

RFQ COPY
 TYPE NAME/ADDRESS HERE
 Mountain State Building Automation
 6444 Sissonville Dr
 Sissonville, WV 25320

SHIP TO

HEALTH AND HUMAN RESOURCES
 WILLIAM R. SHARPE JR. HOSPITAL
 CENTRAL RECEIVING
 936 SHARPE HOSPITAL ROAD
 WESTON, WV
 26452 304-269-1210

DATE PRINTED	TERMS OF SALE	SHIP VIA	FOB	FREIGHT TERMS
07/01/2009				

BID OPENING DATE: 08/04/2009 BID OPENING TIME 01:30PM

LINE	QUANTITY	UOP	CAT NO	ITEM NUMBER	UNIT PRICE	AMOUNT
<p>DIVISION IS THE SOLE AUTHORITY GOVERNING THIS PROCUREMENT.</p> <p>ANY INFORMATION PROVIDED IN SPECIFICATION MANUALS, OR ANY OTHER SOURCE, VERBAL OR WRITTEN, WHICH CONTRADICTS OR ALTERS THE INFORMATION PROVIDED FROM THE SOURCES AS DESCRIBED IN THE ABOVE PARAGRAPH IS VOID AND OF NO EFFECT.</p> <p>BANKRUPTCY: IN THE EVENT THE VENDOR/CONTRACTOR FILES FOR BANKRUPTCY PROTECTION, THE STATE MAY DEEM THE CONTRACT NULL AND VOID AND TERMINATE SUCH CONTRACT WITHOUT FURTHER ORDER.</p> <p>REV. 5/2009</p> <p style="text-align: center;">NOTICE</p> <p>A SIGNED BID MUST BE SUBMITTED TO:</p> <p style="text-align: center;">DEPARTMENT OF ADMINISTRATION PURCHASING DIVISION BUILDING 15 2019 WASHINGTON STREET, EAST CHARLESTON, WV 25305-0130</p> <p>PLEASE NOTE: A CONVENIENCE COPY WOULD BE APPRECIATED.</p> <p>THE BID SHOULD CONTAIN THIS INFORMATION ON THE FACE OF THE ENVELOPE OR THE BID MAY NOT BE CONSIDERED:</p> <p>SEALED BID</p> <p>BUYER:-----RW/FILE 22-----</p> <p>REQ. NO.:-----WSH10002-----</p>						

SEE REVERSE SIDE FOR TERMS AND CONDITIONS

SIGNATURE	TELEPHONE (304) 984-0415	DATE 8/19/09
TITLE Vice President	FERN 26-3312652	ADDRESS CHANGES TO BE NOTED ABOVE

WHEN RESPONDING TO RFQ, INSERT NAME AND ADDRESS IN SPACE ABOVE LABELED 'VENDOR'



State of West Virginia
 Department of Administration
 Purchasing Division
 2019 Washington Street East
 Post Office Box 50130
 Charleston, WV 25305-0130

Request for Quotation

RFQ NUMBER:
 WSH10002

PAGE:
 5

ADDRESS CORRESPONDENCE TO ATTENTION OF:
 ROBERTA WAGNER
 304-558-0067

RFQ COPY
 TYPE NAME/ADDRESS HERE
 Mountain State Building Automation
 6444 Sissonville Dr
 Sissonville, WV 25320

SHIP TO
 HEALTH AND HUMAN RESOURCES
 WILLIAM R. SHARPE JR. HOSPITAL
 CENTRAL RECEIVING
 936 SHARPE HOSPITAL ROAD
 WESTON, WV 26452 304-269-1210

DATE PRINTED	TERMS OF SALE	SHIP VIA	F.O.B.	FREIGHT TERMS
07/01/2009				

BID OPENING DATE: 08/04/2009 BID OPENING TIME 01:30PM

LINE	QUANTITY	LOP	CAT. NO.	ITEM NUMBER	UNIT PRICE	AMOUNT
BID OPENING DATE: ----- 8/4/2009 ----- BID OPENING TIME: ----- 1:30 PM ----- PLEASE PROVIDE A FAX NUMBER IN CASE IT IS NECESSARY TO CONTACT YOU REGARDING YOUR BID: (304) 984-0124 ----- PLEASE PRINT OR TYPE NAME OF PERSON TO CONTACT CONCERNING THIS QUOTE: CRAIG CARTER -----						
***** THIS IS THE END OF RFQ WSH10002 ***** TOTAL:						\$ 83,670

SEE REVERSE SIDE FOR TERMS AND CONDITIONS

SIGNATURE *[Signature]* TELEPHONE (304) 984-0415 DATE 8/19/09
 TITLE Vice President FEIN 26-3312652 ADDRESS CHANGES TO BE NOTED ABOVE

WHEN RESPONDING TO RFQ, INSERT NAME AND ADDRESS IN SPACE ABOVE LABELED 'VENDOR'

SPECIFICATIONS ACCESS CONTROL SECURITY SYSTEM

West Virginia Department of Health and Human Resources
Bureau for Behavioral Health and Health Facilities
William R. Sharpe, Jr. Hospital
936 Sharpe Hospital Road
Weston, West Virginia 26452

SPECIFICATIONS

William R. Sharpe, Jr. Hospital is seeking bids for the purchase and installation of an access control system designed to include reader in/reader out capabilities at seventeen (17) exterior doors at the facility

GENERAL CONDITIONS

It is the intent of the Hospital to purchase only those services as listed

SCOPE OF WORK

Install proximity card readers, electronic door hardware & ancillary equipment for seventeen (17) exterior doors at William R. Sharpe, Jr. Hospital.

System requirements:

- 1 The hardware equipment must be integrated with vendor provided management software, which will be used by the security office, safety office, maintenance department and the switchboard
- 2 The card reader system must be capable of connecting to the existing Edwards EST III fire alarm system and must comply with all Fire Marshall regulations.
- 3 Proximity card readers must be installed at each of the seventeen (17) exterior doors
- 4 A magnetic lock must be installed at each of the seventeen (17) exterior doors.
- 5 All computer hardware and software equipment required to run the system
- 6 A system to generate and assign 650 access cards to the staff of the hospital
- 7 The system must be capable of expansion and upgrading to include up to a maximum of seventeen (17) video cameras and a maximum of ten (10) additional doors
- 8 Must have a battery back-up system that can power the product temporarily for fifteen (15) minutes during a power outage
- 9 Two year full warranty on all software, hardware, parts and labor.
- 10 The price must include complete installation and labor for the project at minimum prevailing wages for Lewis County if applicable

The successful vendor must be registered with the State of West Virginia and will be required to provide a valid current contractor's license and proof of liability insurance.

A Notice to Proceed Letter will advise the successful vendor when the project is to start. The project must be completed within 120 days of the notice to proceed.

STATE OF WEST VIRGINIA
Purchasing Division

PURCHASING AFFIDAVIT

VENDOR OWING A DEBT TO THE STATE:

West Virginia Code §5A-3-10a provides that: No contract or renewal of any contract may be awarded by the state or any of its political subdivisions to any vendor or prospective vendor when the vendor or prospective vendor or a related party to the vendor or prospective vendor is a debtor and the debt owed is an amount greater than one thousand dollars in the aggregate.

PUBLIC IMPROVEMENT CONTRACTS & DRUG-FREE WORKPLACE ACT:

If this is a solicitation for a public improvement construction contract, the vendor, by its signature below, affirms that it has a written plan for a drug-free workplace policy in compliance with Article 1D, Chapter 21 of the *West Virginia Code*. The vendor must make said affirmation with its bid submission. Further, public improvement construction contract may not be awarded to a vendor who does not have a written plan for a drug-free workplace policy in compliance with Article 1D, Chapter 21 of the *West Virginia Code* and who has not submitted that plan to the appropriate contracting authority in timely fashion. For a vendor who is a subcontractor, compliance with Section 5, Article 1D, Chapter 21 of the *West Virginia Code* may take place before their work on the public improvement is begun.

ANTITRUST:

In submitting a bid to any agency for the state of West Virginia, the bidder offers and agrees that if the bid is accepted the bidder will convey, sell, assign or transfer to the state of West Virginia all rights, title and interest in and to all causes of action it may now or hereafter acquire under the antitrust laws of the United States and the state of West Virginia for price fixing and/or unreasonable restraints of trade relating to the particular commodities or services purchased or acquired by the state of West Virginia. Such assignment shall be made and become effective at the time the purchasing agency tenders the initial payment to the bidder.

I certify that this bid is made without prior understanding, agreement, or connection with any corporation, firm, limited liability company, partnership or person or entity submitting a bid for the same materials, supplies, equipment or services and is in all respects fair and without collusion or fraud. I further certify that I am authorized to sign the certification on behalf of the bidder or this bid.

LICENSING:

Vendors must be licensed and in good standing in accordance with any and all state and local laws and requirements by any state or local agency of West Virginia, including, but not limited to, the West Virginia Secretary of State's Office, the West Virginia Tax Department, West Virginia Insurance Commission, or any other state agencies or political subdivision. Furthermore, the vendor must provide all necessary releases to obtain information to enable the Director or spending unit to verify that the vendor is licensed and in good standing with the above entities.

CONFIDENTIALITY:

The vendor agrees that he or she will not disclose to anyone, directly or indirectly, any such personally identifiable information or other confidential information gained from the agency, unless the individual who is the subject of the information consents to the disclosure in writing or the disclosure is made pursuant to the agency's policies, procedures and rules. Vendor further agrees to comply with the Confidentiality Policies and Information Security Accountability Requirements, set forth in <http://www.state.wv.us/admin/purchase/privacy/noticeConfidentiality.pdf>.

Under penalty of law for false swearing (*West Virginia Code* §61-5-3), it is hereby certified that the vendor affirms and acknowledges the information in this affidavit and is in compliance with the requirements as stated.

Vendor's Name: MOUNTAIN STATE BUILDING AUTOMATION
Authorized Signature:  Date: 8/19/09

State of West Virginia VENDOR PREFERENCE CERTIFICATE

Certification and application* is hereby made for Preference in accordance with *West Virginia Code*, §5A-3-37. (Does not apply to construction contracts). *West Virginia Code*, §5A-3-37, provides an opportunity for qualifying vendors to request (at the time of bid) preference for their residency status. Such preference is an evaluation method only and will be applied only to the cost bid in accordance with the *West Virginia Code*. This certificate for application is to be used to request such preference. The Purchasing Division will make the determination of the Resident Vendor Preference, if applicable.

1. **Application is made for 2.5% resident vendor preference for the reason checked:**
 Bidder is an individual resident vendor and has resided continuously in West Virginia for four (4) years immediately preceding the date of this certification; or,
 Bidder is a partnership, association or corporation resident vendor and has maintained its headquarters or principal place of business continuously in West Virginia for four (4) years immediately preceding the date of this certification; or 80% of the ownership interest of Bidder is held by another individual, partnership, association or corporation resident vendor who has maintained its headquarters or principal place of business continuously in West Virginia for four (4) years immediately preceding the date of this certification; or,
 Bidder is a nonresident vendor which has an affiliate or subsidiary which employs a minimum of one hundred state residents and which has maintained its headquarters or principal place of business within West Virginia continuously for the four (4) years immediately preceding the date of this certification; or,
2. **Application is made for 2.5% resident vendor preference for the reason checked:**
 Bidder is a resident vendor who certifies that, during the life of the contract, on average at least 75% of the employees working on the project being bid are residents of West Virginia who have resided in the state continuously for the two years immediately preceding submission of this bid; or,
3. **Application is made for 2.5% resident vendor preference for the reason checked:**
 Bidder is a nonresident vendor employing a minimum of one hundred state residents or is a nonresident vendor with an affiliate or subsidiary which maintains its headquarters or principal place of business within West Virginia employing a minimum of one hundred state residents who certifies that, during the life of the contract, on average at least 75% of the employees or Bidder's affiliate's or subsidiary's employees are residents of West Virginia who have resided in the state continuously for the two years immediately preceding submission of this bid; or,
4. **Application is made for 5% resident vendor preference for the reason checked:**
 Bidder meets either the requirement of both subdivisions (1) and (2) or subdivision (1) and (3) as stated above; or,
5. **Application is made for 3.5% resident vendor preference who is a veteran for the reason checked:**
 Bidder is an individual resident vendor who is a veteran of the United States armed forces, the reserves or the National Guard and has resided in West Virginia continuously for the four years immediately preceding the date on which the bid is submitted; or,
6. **Application is made for 3.5% resident vendor preference who is a veteran for the reason checked:**
 Bidder is a resident vendor who is a veteran of the United States armed forces, the reserves or the National Guard, if, for purposes of producing or distributing the commodities or completing the project which is the subject of the vendor's bid and continuously over the entire term of the project, on average at least seventy-five percent of the vendor's employees are residents of West Virginia who have resided in the state continuously for the two immediately preceding years.

Bidder understands if the Secretary of Revenue determines that a Bidder receiving preference has failed to continue to meet the requirements for such preference, the Secretary may order the Director of Purchasing to: (a) reject the bid; or (b) assess a penalty against such Bidder in an amount not to exceed 5% of the bid amount and that such penalty will be paid to the contracting agency or deducted from any unpaid balance on the contract or purchase order.

By submission of this certificate, Bidder agrees to disclose any reasonably requested information to the Purchasing Division and authorizes the Department of Revenue to disclose to the Director of Purchasing appropriate information verifying that Bidder has paid the required business taxes, provided that such information does not contain the amounts of taxes paid nor any other information deemed by the Tax Commissioner to be confidential.

Under penalty of law for false swearing (*West Virginia Code*, §61-5-3), Bidder hereby certifies that this certificate is true and accurate in all respects; and that if a contract is issued to Bidder and if anything contained within this certificate changes during the term of the contract, Bidder will notify the Purchasing Division in writing immediately.

Bidder: MUNDAN STATE BUILDING AUTHORITY Signed: [Signature]

Date: 8/19/09 Title: VICE PRESIDENT

*Check any combination of preference consideration(s) indicated above which you are entitled to receive

ATTACHMENT
P O # WSH10002

This agreement constitutes the entire agreement between the parties, and there are no other terms and conditions applicable to the licenses granted hereunder

Agreed

C. [Signature] 8/14/07
Signature Date

Vice President
Title

Munich State Bureau, Arizona
Company Name

Signature Date

Title

Agency/Division

WV-96
Rev. 10/07

AGREEMENT ADDENDUM

In the event of conflict between this addendum and the agreement, this addendum shall control:

1. **DISPUTES** - Any references in the agreement to arbitration or to the jurisdiction of any court are hereby deleted. Disputes arising out of the agreement shall be presented to the West Virginia Court of Claims.
2. **HOLD HARMLESS** - Any clause requiring the Agency to indemnify or hold harmless any party is hereby deleted in its entirety.
3. **GOVERNING LAW** - The agreement shall be governed by the laws of the State of West Virginia. This provision replaces any references to any other State's governing law.
4. **TAXES** - Provisions in the agreement requiring the Agency to pay taxes are deleted. As a State entity, the Agency is exempt from Federal, State, and local taxes and will not pay taxes for any Vendor including individuals, nor will the Agency file any tax returns or reports on behalf of Vendor or any other party.
5. **PAYMENT** - Any references to prepayment are deleted. Payment will be in arrears.
6. **INTEREST** - Should the agreement include a provision for interest on late payments, the Agency agrees to pay the maximum legal rate under West Virginia law. All other references to interest or late charges are deleted.
7. **RECOUPMENT** - Any language in the agreement waiving the Agency's right to set-off, counterclaim, recoupment, or other defense is hereby deleted.
8. **FISCAL YEAR FUNDING** - Service performed under the agreement may be continued in succeeding fiscal years for the term of the agreement, contingent upon funds being appropriated by the Legislature or otherwise being available for this service. In the event funds are not appropriated or otherwise available for this service, the agreement shall terminate without penalty on June 30. After that date, the agreement becomes of no effect and is null and void. However, the Agency agrees to use its best efforts to have the amounts contemplated under the agreement included in its budget. Non-appropriation or non-funding shall not be considered an event of default.
9. **STATUTE OF LIMITATION** - Any clauses limiting the time in which the Agency may bring suit against the Vendor, lessor, individual, or any other party are deleted.
10. **SIMILAR SERVICES** - Any provisions limiting the Agency's right to obtain similar services or equipment in the event of default or non-funding during the term of the agreement are hereby deleted.
11. **ATTORNEY FEES** - The Agency recognizes an obligation to pay attorney's fees or costs only when assessed by a court of competent jurisdiction. Any other provision is invalid and considered null and void.
12. **ASSIGNMENT** - Notwithstanding any clause to the contrary, the Agency reserves the right to assign the agreement to another State of West Virginia agency, board or commission upon thirty (30) days written notice to the Vendor and Vendor shall obtain the written consent of Agency prior to assigning the agreement.
13. **LIMITATION OF LIABILITY** - The Agency, as a State entity, cannot agree to assume the potential liability of a Vendor. Accordingly, any provision limiting the Vendor's liability for direct damages to a certain dollar amount or to the amount of the agreement is hereby deleted. Limitations on special, incidental or consequential damages are acceptable. In addition, any limitation is null and void to the extent that it precludes any action for injury to persons or for damages to personal property.
14. **RIGHT TO TERMINATE** - Agency shall have the right to terminate the agreement upon thirty (30) days written notice to Vendor. Agency agrees to pay Vendor for services rendered or goods received prior to the effective date of termination.
15. **TERMINATION CHARGES** - Any provision requiring the Agency to pay a fixed amount or liquidated damages upon termination of the agreement is hereby deleted. The Agency may only agree to reimburse a Vendor for actual costs incurred or losses sustained during the current fiscal year due to wrongful termination by the Agency prior to the end of any current agreement term.
16. **RENEWAL** - Any reference to automatic renewal is hereby deleted. The agreement may be renewed only upon mutual written agreement of the parties.
17. **INSURANCE** - Any provision requiring the Agency to insure equipment or property of any kind and name the Vendor as beneficiary or as an additional insured is hereby deleted.
18. **RIGHT TO NOTICE** - Any provision for repossession of equipment without notice is hereby deleted. However, the Agency does recognize a right of repossession with notice.
19. **ACCELERATION** - Any reference to acceleration of payments in the event of default or non-funding is hereby deleted.
20. **CONFIDENTIALITY** - Any provision regarding confidentiality of the terms and conditions of the agreement is hereby deleted. State contracts are public records under the West Virginia Freedom of Information Act.
21. **AMENDMENTS** - All amendments, modifications, alterations or changes to the agreement shall be in writing and signed by both parties. No amendment, modification, alteration or change may be made to this addendum without the express written approval of the Purchasing Division and the Attorney General.

ACCEPTED BY:

STATE OF WEST VIRGINIA

Spending Unit: _____

Signed: _____

Title: _____

Date: _____

VENDOR

Company Name: MANITOW STATE BUILDING AUTOMATION

Signed: C. C. [Signature]

Title: VICE PRESIDENT

Date: 8/19/09



State of West Virginia
 Department of Administration
 Purchasing Division
 2019 Washington Street East
 Post Office Box 50130
 Charleston, WV 25305-0130

Request for Quotation

RFQ NUMBER
WSH10002

PAGE
1

ADDRESS CORRESPONDENCE TO ATTENTION OF
ROBERTA WAGNER 304-558-0067

SUBJECT

RFQ COPY
 TYPE NAME/ADDRESS HERE
 Mountain State Building Automation
 6444 Sissonville Dr
 Sissonville, WV 25320

SHIP TO

HEALTH AND HUMAN RESOURCES
 WILLIAM R. SHARPE JR. HOSPITAL
 CENTRAL RECEIVING
 936 SHARPE HOSPITAL ROAD
 WESTON, WV
 26452 304-269-1210

DATE PRINTED	TERMS OF SALE	SHIP VIA	FOB	FREIGHT TERMS
07/24/2009				

BID OPENING DATE: 08/18/2009 BID OPENING TIME 01:30PM

LINE	QUANTITY	UOP	CAT NO	ITEM NUMBER	UNIT PRICE	AMOUNT
ADDENDUM NO. 1						
1. TO MOVE THE BID OPENING DATE FROM 8/4/2009 TO 8/18/2009. PRE-BID SIGN-IN SHEET ATTACHED. 2. ADDENDUM ACKNOWLEDGEMENT IS ATTACHED. THIS DOCUMENT SHOULD BE SIGNED AND RETURNED WITH YOUR BID. FAILURE TO SIGN AND RETURN MAY RESULT IN DISQUALIFICATION OF YOUR BID.						
EXHIBIT 10						
REQUISITION NO. : WSH10002						
ADDENDUM ACKNOWLEDGEMENT						
I HEREBY ACKNOWLEDGE RECEIPT OF THE FOLLOWING CHECKED ADDENDUM(S) AND HAVE MADE THE NECESSARY REVISIONS TO MY PROPOSAL, PLANS AND/OR SPECIFICATION, ETC.						
ADDENDUM NO. S:						
NO 1 CEC 8/19/09						
NO 2 CEC 8/19/09						
NO 3 CEC 8/19/09						

SEE REVERSE SIDE FOR TERMS AND CONDITIONS

SIGNATURE <i>C. C. [Signature]</i>	TELEPHONE (304) 984-0415	DATE 8/19/09
TITLE Vice President	FEIN 26-3312652	ADDRESS CHANGES TO BE NOTED ABOVE

WHEN RESPONDING TO RFQ, INSERT NAME AND ADDRESS IN SPACE ABOVE LABELED 'VENDOR'

GENERAL TERMS & CONDITIONS REQUEST FOR QUOTATION (RFQ) AND REQUEST FOR PROPOSAL (RFP)

1. Awards will be made in the best interest of the State of West Virginia.
2. The State may accept or reject in part, or in whole, any bid.
3. All quotations are governed by the *West Virginia Code* and the *Legislative Rules* of the Purchasing Division.
4. Prior to any award, the apparent successful vendor must be properly registered with the Purchasing Division and have paid the required \$125 fee.
5. All services performed or goods delivered under State Purchase Order/Contracts are to be continued for the term of the Purchase Order/Contracts, contingent upon funds being appropriated by the Legislature or otherwise being made available. In the event funds are not appropriated or otherwise available for these services or goods, this Purchase Order/Contract becomes void and of no effect after June 30.
6. Payment may only be made after the delivery and acceptance of goods or services.
7. Interest may be paid for late payment in accordance with the *West Virginia Code*.
8. Vendor preference will be granted upon written request in accordance with the *West Virginia Code*.
9. The State of West Virginia is exempt from federal and state taxes and will not pay or reimburse such taxes.
10. The Director of Purchasing may cancel any Purchase Order/Contract upon 30 days written notice to the seller.
11. The laws of the State of West Virginia and the *Legislative Rules* of the Purchasing Division shall govern all rights and duties under the Contract, including without limitation the validity of this Purchase Order/Contract.
12. Any reference to automatic renewal is hereby deleted. The Contract may be renewed only upon mutual written agreement of the parties.
13. **BANKRUPTCY:** In the event the vendor/contractor files for bankruptcy protection, the State may deem this contract null and void, and terminate such contract without further order.
14. **HIPAA BUSINESS ASSOCIATE ADDENDUM:** The West Virginia State Government HIPAA Business Associate Addendum (BAA), approved by the Attorney General, and available online at the Purchasing Division's web site (<http://www.state.wv.us/admin/purchase/vrc/hipaa.htm>) is hereby made part of the agreement. Provided that, the Agency meets the definition of a Cover Entity (45 CFR §160.103) and will be disclosing Protected Health Information (45 CFR §160.103) to the vendor.
15. **WEST VIRGINIA ALCOHOL & DRUG-FREE WORKPLACE ACT:** If this Contract constitutes a public improvement construction contract as set forth in Article 1D, Chapter 21 of the West Virginia Code ("The West Virginia Alcohol and Drug-Free Workplace Act"), then the following language shall hereby become part of this Contract: "The contractor and its subcontractors shall implement and maintain a written drug-free workplace policy in compliance with the West Virginia Alcohol and Drug-Free Workplace Act, as set forth in Article 1D, Chapter 21 of the West Virginia Code. The contractor and its subcontractors shall provide a sworn statement in writing, under the penalties of perjury, that they maintain a valid drug-free workplace policy in compliance with the West Virginia Alcohol and Drug-Free Workplace Act. It is understood and agreed that this Contract shall be cancelled by the awarding authority if the Contractor: 1) Fails to implement its drug-free workplace policy; 2) Fails to provide information regarding implementation of the contractor's drug-free workplace policy at the request of the public authority; or 3) Provides to the public authority false information regarding the contractor's drug-free workplace policy."

INSTRUCTIONS TO BIDDERS

1. Use the quotation forms provided by the Purchasing Division.
2. **SPECIFICATIONS:** Items offered must be in compliance with the specifications. Any deviation from the specifications must be clearly indicated by the bidder. Alternates offered by the bidder as **EQUAL** to the specifications must be clearly defined. A bidder offering an alternate should attach complete specifications and literature to the bid. The Purchasing Division may waive minor deviations to specifications.
3. Complete all sections of the quotation form.
4. Unit prices shall prevail in case of discrepancy.
5. All quotations are considered F.O.B. destination unless alternate shipping terms are clearly identified in the quotation.
6. **BID SUBMISSION:** All quotations must be delivered by the bidder to the office listed below prior to the date and time of the bid opening. Failure of the bidder to deliver the quotations on time will result in bid disqualifications: Department of Administration, Purchasing Division, 2019 Washington Street East, P.O. Box 50130, Charleston, WV 25305-0130.



State of West Virginia
 Department of Administration
 Purchasing Division
 2019 Washington Street East
 Post Office Box 50130
 Charleston, WV 25305-0130

Request for Quotation

RFQ NUMBER
WSH10002

PAGE
2

ADDRESS CORRESPONDENCE TO ATTENTION OF
ROBERTA WAGNER 304-558-0067

RFQ COPY
 TYPE NAME/ADDRESS HERE
 Mountain State Building Automation
 6444 Sissonville Dr
 Sissonville, WV 25320

HEALTH AND HUMAN RESOURCES
 WILLIAM R. SHARPE JR. HOSPITAL
 CENTRAL RECEIVING
 936 SHARPE HOSPITAL ROAD
 WESTON, WV 26452 304-269-1210

DATE PRINTED	TERMS OF SALE	SHIP VIA	F.O.B.	FREIGHT TERMS
07/24/2009				
BID OPENING DATE:	08/18/2009	BID OPENING TIME		01:30PM

LINE	QUANTITY	UOP	CAT. NO.	ITEM NUMBER	UNIT PRICE	AMOUNT
NO. 4						
NO. 5						
<p>I UNDERSTAND THAT FAILURE TO CONFIRM THE RECEIPT OF THE ADDENDUM(S) MAY BE CAUSE FOR REJECTION OF BIDS.</p> <p>VENDOR MUST CLEARLY UNDERSTAND THAT ANY VERBAL REPRESENTATION MADE OR ASSUMED TO BE MADE DURING ANY ORAL DISCUSSION HELD BETWEEN VENDOR'S REPRESENTATIVES AND ANY STATE PERSONNEL IS NOT BINDING. ONLY THE INFORMATION ISSUED IN WRITING AND ADDED TO THE SPECIFICATIONS BY AN OFFICIAL ADDENDUM IS BINDING.</p> <p style="text-align: center;">  SIGNATURE MOUNTAIN STATE BUILDING AUTOMATION COMPANY 8/19/09 DATE </p> <p>REV. 11/96</p> <p>ADDENDUM NO. 1</p>						

SEE REVERSE SIDE FOR TERMS AND CONDITIONS			
SIGNATURE	TELEPHONE	DATE	
	(304) 984-0415	8/19/09	
TITLE Vice President	FEIN 26-3312652	ADDRESS CHANGES TO BE NOTED ABOVE	

WHEN RESPONDING TO RFQ, INSERT NAME AND ADDRESS IN SPACE ABOVE LABELED 'VENDOR'



State of West Virginia
 Department of Administration
 Purchasing Division
 2019 Washington Street East
 Post Office Box 50130
 Charleston, WV 25305-0130

Request for Quotation

RFQ NUMBER
 WSH10002

PAGE
 3

ADDRESS CORRESPONDENCE TO ATTENTION OF:
 ROBERTA WAGNER
 304-558-0067

RFQ COPY

TYPE NAME/ADDRESS HERE
 Mountain State Building Automation
 6444 Sissonville Dr
 Sissonville, WV 25320

SHIP TO

HEALTH AND HUMAN RESOURCES
 WILLIAM R. SHARPE JR. HOSPITAL
 CENTRAL RECEIVING
 936 SHARPE HOSPITAL ROAD
 WESTON, WV
 26452 304-269-1210

DATE PRINTED	TERMS OF SALE	SHIP VIA	F.O.B.	FREIGHT TERMS
07/24/2009				

BID OPENING DATE: 08/18/2009 BID OPENING TIME: 01:30PM

LINE	QUANTITY	UOP	CAT NO	ITEM NUMBER	UNIT PRICE	AMOUNT
0001	1	JB		990-22		\$ 83,650
ACCESS CONTROL SECURITY SYSTEM						
***** THIS IS THE END OF RFQ WSH10002 ***** TOTAL:						\$ 83,650

SEE REVERSE SIDE FOR TERMS AND CONDITIONS

SIGNATURE: *[Signature]* TELEPHONE: (304) 984-0415 DATE: 8/19/09
 TITLE: Vice President FEIN: 26-3312652 ADDRESS CHANGES TO BE NOTED ABOVE

WHEN RESPONDING TO RFQ, INSERT NAME AND ADDRESS IN SPACE ABOVE LABELED 'VENDOR'

MANDATORY PRE-BID MEETING - 7/15/09 at 1:00pm

William R. Sharpe, Jr Hospital - RFQ WSH10002
Access Control Security System

SIGN IN SHEET

Vendor Name Representative Name	Mailing Address	Telephone # Fax #
1. <u>MSBA - CRAIG CARTER</u>	<u>CHAS. WV</u> <u>4444 SILVERVILLE DR.</u>	(F) <u>304 984-0124</u> (T) <u>304 941-9331</u>
2. <u>Global Tech Communications</u>	<u>4760 Chimney Drive</u> <u>Big Chimney, WV 25302</u>	(T) <u>304 345-5530</u>
3. <u>Chad Morris + Bill Simpson</u> <u>Long Security Assoc Sys LLC</u> <u>Earl Moyer</u> <u>Advanced</u> <u>Earl Moyer</u>	<u>102 39th ST SE.</u> <u>Charleston WV 25304</u>	(T) <u>304-925-0338</u> (F) <u>304-925-0338</u>
4. <u>Advanced Alarm Technologies</u>	<u>PO Box 4368</u> <u>Parkersburg WV. 26109</u>	(T) <u>304-422-4387</u>
5. <u>Miller Communications Inc</u> <u>WERNER KNECHT</u>	<u>One Wireless Way, Suite 100</u> <u>Sta Parkersburg WV 26101</u>	(T) <u>304-863-8595</u> (F) <u>304 863-3786</u>
6. <u>NEWTECH SYSTEMS INC</u> <u>DIANE TEBBET</u>	<u>420 16th STREET</u> <u>DUNBAR, WV 25064</u>	(T) <u>304-766-0000</u> (F) <u>304 766-0003</u>
7. <u>SIMPSON TECH SERV</u> <u>MARK SIMPSON</u>	<u>519 HIGHLAND AVE</u> <u>So. CHAS. WV 25309</u> <u>Dunbar WV</u>	(T) <u>304 744-5601</u> <u>304-766-6277</u>
8. <u>Bill Miller / Kevin</u> <u>Electronic Specialty Com</u>	<u>1325 Dunbar, Ave</u>	(T) <u>304 766 6270</u>

MANDATORY PRE-BID MEETING - 7/15/09 at 1:00pm

William R. Sharpe, Jr. Hospital - RFQ WSH10002
Access Control Security System

9.	<u>Rob Haxell</u>	<u>525 E Main St.</u>	<u>(t) 304-842-6030</u>
	<u>United Bond + Elect</u>	<u>Bridgport, W.V.</u>	<u>(f) 304-842-7160</u>
10.	_____	_____	(t) _____
	_____	_____	(f) _____
11	_____	_____	(t) _____
	_____	_____	(f) _____
12	_____	_____	(t) _____
	_____	_____	(f) _____
13	_____	_____	(t) _____
	_____	_____	(f) _____
14	_____	_____	(t) _____
	_____	_____	(f) _____
15	_____	_____	(t) _____
	_____	_____	(f) _____
16	_____	_____	(t) _____
	_____	_____	(f) _____
17	_____	_____	(t) _____
	_____	_____	(f) _____



State of West Virginia
 Department of Administration
 Purchasing Division
 2019 Washington Street East
 Post Office Box 50130
 Charleston, WV 25305-0130

Request for Quotation

RFQ NUMBER
 WSH10002

PAGE
 1

ADDRESS CORRESPONDENCE TO ATTENTION OF:
 ROBERTA WAGNER
 304-558-0067

VENDOR

RFQ COPY
 TYPE NAME/ADDRESS HERE
 Mountain State Building Automation
 6444 Sissonville Drive
 Sissonville, WV 25320

SHIP TO

HEALTH AND HUMAN RESOURCES
 WILLIAM R. SHARPE JR. HOSPITAL
 CENTRAL RECEIVING
 936 SHARPE HOSPITAL ROAD
 WESTON, WV 26452 304-269-1210

DATE PRINTED	TERMS OF SALE	SHIP VIA	F.O.B.	FREIGHT TERMS
07/28/2009				

BID OPENING DATE: 08/18/2009 BID OPENING TIME 01:30PM

LINE	QUANTITY	UOP	CAT NO	ITEM NUMBER	UNIT PRICE	AMOUNT
ADDENDUM NO. 2						
1. QUESTIONS AND ANSWERS ARE ATTACHED 2. ADDENDUM ACKNOWLEDGEMENT IS ATTACHED THIS DOCUMENT SHOULD BE SIGNED AND RETURNED WITH YOUR BID. FAILURE TO SIGN AND RETURN MAY RESULT IN DISQUALIFICATION OF YOUR BID.						
EXHIBIT 10						
REQUISITION NO.: WSH10002						
ADDENDUM ACKNOWLEDGEMENT						
I HEREBY ACKNOWLEDGE RECEIPT OF THE FOLLOWING CHECKED ADDENDUM(S) AND HAVE MADE THE NECESSARY REVISIONS TO MY PROPOSAL, PLANS AND/OR SPECIFICATION, ETC.						
ADDENDUM NO. S:						
NO. 1				CEC 8/19/09		
NO. 2				CEC 8/19/09		
NO. 3				CEC 8/19/09		
NO. 4						
NO. 5						
I UNDERSTAND THAT FAILURE TO CONFIRM THE RECEIPT OF TH						

SEE REVERSE SIDE FOR TERMS AND CONDITIONS

SIGNATURE <i>C. C. C.</i>	TELEPHONE (304) 984-0415	DATE 8/19/09
TITLE Vice President	FEIN 26-3312652	ADDRESS CHANGES TO BE NOTED ABOVE

WHEN RESPONDING TO RFQ, INSERT NAME AND ADDRESS IN SPACE ABOVE LABELED 'VENDOR'

**GENERAL TERMS & CONDITIONS
REQUEST FOR QUOTATION (RFQ) AND REQUEST FOR PROPOSAL (RFP)**

1. Awards will be made in the best interest of the State of West Virginia.
2. The State may accept or reject in part, or in whole, any bid.
3. All quotations are governed by the *West Virginia Code* and the *Legislative Rules* of the Purchasing Division.
4. Prior to any award, the apparent successful vendor must be properly registered with the Purchasing Division and have paid the required \$125 fee.
5. All services performed or goods delivered under State Purchase Order/Contracts are to be continued for the term of the Purchase Order/Contracts, contingent upon funds being appropriated by the Legislature or otherwise being made available. In the event funds are not appropriated or otherwise available for these services or goods, this Purchase Order/Contract becomes void and of no effect after June 30.
6. Payment may only be made after the delivery and acceptance of goods or services.
7. Interest may be paid for late payment in accordance with the *West Virginia Code*.
8. Vendor preference will be granted upon written request in accordance with the *West Virginia Code*.
9. The State of West Virginia is exempt from federal and state taxes and will not pay or reimburse such taxes.
10. The Director of Purchasing may cancel any Purchase Order/Contract upon 30 days written notice to the seller.
11. The laws of the State of West Virginia and the *Legislative Rules* of the Purchasing Division shall govern all rights and duties under the Contract, including without limitation the validity of this Purchase Order/Contract.
12. Any reference to automatic renewal is hereby deleted. The Contract may be renewed only upon mutual written agreement of the parties.
13. **BANKRUPTCY:** In the event the vendor/contractor files for bankruptcy protection, the State may deem this contract null and void, and terminate such contract without further order.
14. **HIPAA BUSINESS ASSOCIATE ADDENDUM:** The West Virginia State Government HIPAA Business Associate Addendum (BAA), approved by the Attorney General, and available online at the Purchasing Division's web site (<http://www.state.wv.us/admin/purchase/vrc/hipaa.htm>) is hereby made part of the agreement. Provided that, the Agency meets the definition of a Cover Entity (45 CFR §160.103) and will be disclosing Protected Health Information (45 CFR §160.103) to the vendor.
15. **WEST VIRGINIA ALCOHOL & DRUG-FREE WORKPLACE ACT:** If this Contract constitutes a public improvement construction contract as set forth in Article 1D, Chapter 21 of the West Virginia Code ("The West Virginia Alcohol and Drug-Free Workplace Act"), then the following language shall hereby become part of this Contract: "The contractor and its subcontractors shall implement and maintain a written drug-free workplace policy in compliance with the West Virginia Alcohol and Drug-Free Workplace Act, as set forth in Article 1D, Chapter 21 of the West Virginia Code. The contractor and its subcontractors shall provide a sworn statement in writing, under the penalties of perjury, that they maintain a valid drug-free work place policy in compliance with the West Virginia and Drug-Free Workplace Act. It is understood and agreed that this Contract shall be cancelled by the awarding authority if the Contractor: 1) Fails to implement its drug-free workplace policy; 2) Fails to provide information regarding implementation of the contractor's drug-free workplace policy at the request of the public authority; or 3) Provides to the public authority false information regarding the contractor's drug-free workplace policy."

INSTRUCTIONS TO BIDDERS

1. Use the quotation forms provided by the Purchasing Division.
2. **SPECIFICATIONS:** Items offered must be in compliance with the specifications. Any deviation from the specifications must be clearly indicated by the bidder. Alternates offered by the bidder as **EQUAL** to the specifications must be clearly defined. A bidder offering an alternate should attach complete specifications and literature to the bid. The Purchasing Division may waive minor deviations to specifications.
3. Complete all sections of the quotation form.
4. Unit prices shall prevail in case of discrepancy.
5. All quotations are considered F.O.B. destination unless alternate shipping terms are clearly identified in the quotation.
6. **BID SUBMISSION:** All quotations must be delivered by the bidder to the office listed below prior to the date and time of the bid opening. Failure of the bidder to deliver the quotations on time will result in bid disqualifications: Department of Administration, Purchasing Division, 2019 Washington Street East, P.O. Box 50130, Charleston, WV 25305-0130.



State of West Virginia
 Department of Administration
 Purchasing Division
 2019 Washington Street East
 Post Office Box 50130
 Charleston, WV 25305-0130

Request for Quotation

RFQ NUMBER
WSH10002

PAGE
2

ADDRESS CORRESPONDENCE TO ATTENTION OF:
ROBERTA WAGNER 304-558-0067

RFQ COPY
 TYPE NAME/ADDRESS HERE
 Mountain State Building Automation
 6444 Sissonville Drive
 Sissonville, WV 25320

SHIP TO
 HEALTH AND HUMAN RESOURCES
 WILLIAM R. SHARPE JR. HOSPITAL
 CENTRAL RECEIVING
 936 SHARPE HOSPITAL ROAD
 WESTON, WV 26452 304-269-1210

DATE PRINTED	TERMS OF SALE	SHIP VIA	F.O.B.	FREIGHT TERMS
07/28/2009				

BID OPENING DATE: 08/18/2009 BID OPENING TIME 01:30PM

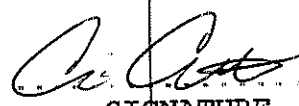
LINE	QUANTITY	UOP	CAT. NO.	ITEM NUMBER	UNIT PRICE	AMOUNT
<p>ADDENDUM(S) MAY BE CAUSE FOR REJECTION OF BIDS.</p> <p>VENDOR MUST CLEARLY UNDERSTAND THAT ANY VERBAL REPRESENTATION MADE OR ASSUMED TO BE MADE DURING ANY ORAL DISCUSSION HELD BETWEEN VENDOR'S REPRESENTATIVES AND ANY STATE PERSONNEL IS NOT BINDING. ONLY THE INFORMATION ISSUED IN WRITING AND ADDED TO THE SPECIFICATIONS BY AN OFFICIAL ADDENDUM IS BINDING.</p> <p style="text-align: center;">  SIGNATURE MOUNTAIN STATE BUILDING AUTOMATION COMPANY 8/19/09 DATE </p> <p>REV 11/96</p> <p>END OF ADDENDUM NO. 2</p>						

SEE REVERSE SIDE FOR TERMS AND CONDITIONS

SIGNATURE 	TELEPHONE (304) 984-0415	DATE 8/19/09
TITLE Vice President	FEB# 26-3312652	ADDRESS CHANGES TO BE NOTED ABOVE

WHEN RESPONDING TO RFQ, INSERT NAME AND ADDRESS IN SPACE ABOVE LABELED 'VENDOR'



State of West Virginia
 Department of Administration
 Purchasing Division
 2019 Washington Street East
 Post Office Box 50130
 Charleston, WV 25305-0130

Request for Quotation

RFQ NUMBER:
 WSH10002

PAGE:
 3

ADDRESS CORRESPONDENCE TO ATTENTION OF:
 ROBERTA WAGNER
 304-558-0067

RFQ COPY
 TYPE NAME/ADDRESS HERE
 Mountain State Building Automation
 6444 Sissonville Drive
 Sissonville, WV 25320

SHIP TO
 HEALTH AND HUMAN RESOURCES
 WILLIAM R. SHARPE JR. HOSPITAL
 CENTRAL RECEIVING
 936 SHARPE HOSPITAL ROAD
 WESTON, WV
 26452 304-269-1210

DATE PRINTED	TERMS OF SALE	SHIP VIA	F.O.B.	FREIGHT TERMS
07/28/2009				

BID OPENING DATE: 08/18/2009 BID OPENING TIME 01:30PM

LINE	QUANTITY	UOP	CAT NO	ITEM NUMBER	UNIT PRICE	AMOUNT
0001	1	JB		990-22		\$83,650
ACCESS CONTROL SECURITY SYSTEM						
***** THIS IS THE END OF RFQ WSH10002 ***** TOTAL:						\$83,650

SEE REVERSE SIDE FOR TERMS AND CONDITIONS

SIGNATURE: *[Signature]* TELEPHONE: (304) 984-0415 DATE: 8/19/09

TITLE: Vice President FEIN: 26-3312652 ADDRESS CHANGES TO BE NOTED ABOVE

WHEN RESPONDING TO RFQ, INSERT NAME AND ADDRESS IN SPACE ABOVE LABELED 'VENDOR'

To response to vendor questions, as follows:

- 1 Maps of the facilities?
Enclosed are three maps (Door Locations, Computer Network Locations, and Ceiling Types)
2. What are we looking for in terms of Administrative Management?
We want the system to allow for at least 3 administrator accounts to do maintenance.
- 3 What specifications do you have for the cameras system?

Cameras* = (All specs need to be equivalent or better)

- A The Camera shall function as a video surveillance camera with ultra-wide dynamic range in indoor or outdoor applications.
- B. The Camera shall be as manufactured by a reputable nationally recognized company.
- C The Camera housing shall be constructed of heavy-duty aluminum with a polycarbonate style dome.
 - The housing shall have an IP66 weather resistance rating
 - The housing shall include a captive shroud to conceal camera position
 - The housing shall utilize a mechanism to allow for optimization of the field of view in various mounting locations
- D The camera shall meet or exceed the following specifications:
 - The camera shall have Wide Dynamic Range technology, where each pixel is individually optimized to show details in shadows and highlights.
 - The camera shall have a dynamic range of 95 dB typical
 - The maximum dynamic range of the camera shall be 120 dB
 - The signal system shall be NTSC or PAL, selectable
 - The scanning system shall be 525/60 for NTSC and 625/50 for PAL.
 - The synchronization shall be internal or AC line lock
 - The overall resolution that the camera provides shall be 540 television lines
 - The camera shall have 720 horizontal and 540 vertical picture elements NTSC
 - The signal-to-noise ratio shall be better than 49 dB.
 - The gamma compensation shall be 0.45 NTSC or 0.36 PAL.
 - The frame integration shall be between 2x and 32x.
 - The camera shall have color balance and white balance as AWB or AIW-Extend.
 - The camera shall have automatic gain control, fully programmable
 - The camera shall have a composite video output
 - The video output shall be 1.0 V p-p at 75-ohm load.

E. The environmental specifications for the dome shall be as follows:

- Operating temperature shall be -58 to 122 degrees Fahrenheit or -50 to 50 degrees Celsius.

Network DVR * = (All specs need to be equivalent or better)

Minimum requirements

A Workstation requirements may vary based on system size and customer specific application requirements. Increasing memory capacity, hard drive capacity, processor speed, as well as specifying single dual core or dual processors, and multi-monitor displays shall be considered and recommended when required above minimum specifications

- Up to 15 frames per second at 2 CIF resolution
- 30 days storage at 7 FPS 2 CIF resolution
- Software based Integration with Access Control software -- video will pop up inside of access software based on alarms. (No hardware integration -- software only)
- Hybrid based -- will record up to but not limited to 32 digital or analog cameras or encoder streams
- View video through IP based browser (Internet Explorer)
- Must be UL and CE listed
- Internal Dual Layer DVDRW
- Intel® Core™ i7-975 (3 33GHz, 8MB L3 Cache)
(If this item is not available, then Intel Core 2 Quad with shared L2 cache and 1333 MHz Front Side Bus can substituted)
- 8 GB RAM.
- 2 ea 1 Terabyte HD configurable to be supported by Raid-1 redundancy
- 25-inch LCD display, supporting a minimum 32bit high color at 1440x900 resolution
- 1000MB Ethernet Network Interface Card.
- Standard 101-key keyboard and 2-button wheel mouse

B Network DVR shall include the following connectors * = (All specs need to be equivalent or better)

- Accessory I/O ports
- RS-485/422 (2)
- Alarm input (4, 8 or 16)
- Form C alarm relay (2)
- USB (3)
- Two connectors shall be located on the back panel and one on the front panel.
- RS-232 serial port: DB-9
- Composite video in: BNC (4, 8 or 16), looping auto terminating
- Composite video out, Monitor A: BNC (1)

- Analog video out Monitor A: VGA (1)
- Composite video out, Monitor B: BNC (1)
- Audio in: RCA (2)
- Audio out: RCA (1)
- 1000 Ethernet: RJ-45 (1)

DVR Control Software * = (All specs need to be equivalent or better)

A. Architecture:

- The SMS (Software Management System) shall be a scalable Microsoft Windows based client/server application for deployment of integrated security operations to include system configuration management & administration, command & control, and real-time monitoring for access control, alarm management, video surveillance, photo ID credentialing, and interfacing with secondary security subsystems and business database applications.
- The SMS application shall be a true 32bit application; supported on Microsoft Windows XP, Vista, Server 2003 Operating Systems on 32bit server deployments.
- The SMS database shall be supported on Microsoft based 32bit architecture.
- The SMS deployment shall allow but not require, the separation of database server, file server, and application server roles to provide maximum flexibility and conformance with IT data center deployment practices

B Operator Interface:

- The SMS shall use a Windows based client application interface for system configuration management, administration, and monitoring operations.
- The SMS shall provide a mouse-driven, Windows based, graphical user interface allowing operator(s) to open and work on multiple application windows simultaneously, at host server and client workstation(s) with minimal degradation to system performance.
- The SMS shall support defining an unlimited number of operators; application access via workstation(s) shall be restricted by operator login and password. Operator passwords shall be stored in an encrypted manner. The SMS shall provide the ability to setup password rules for password length and expiration periods for system operators.
- The SMS shall allow operator authentication through an Active Directory Server, bypassing SMS storing passwords. Operator access with the SMS shall continue to be defined within the SMS configuration forms

C Program Interface: The SMS shall support a program interface (PI), which allows authorized connections between the SMS and external systems for developing custom interfaces and providing tightly coupled integrated solutions. The PI for the SMS shall facilitate real-time response to monitored events processed by the SMS as well as control of devices managed by the SMS

- The SMS shall only allow authorized connections through the PI
- The SMS shall allow up to twenty-five (25) concurrent connections to external systems through the PI.
- The PI shall expose the following aspects of the SMS:
 1. Bi-directional alarm event processing for monitoring and acknowledgement
 2. b Receiving SMS card access activity events
 3. Receiving digital input events
 4. Receiving intrusion zone events
 5. Control of operator logins
 6. Control of alarm point monitoring On/Off
 7. Control of digital input points Enable/Disable
 8. Control of digital output points Open/Close
 9. Control of intrusion zones Arm/Disarm
 10. Control of control panel Modes

D. Application & Database Server:

- Professional Class Platform: Microsoft Windows XP or Server 2003
- Enterprise Class Server Platform: Microsoft Server 2003 32bit

E. Client Workstations:

- Microsoft Windows [XP or Vista]
- Intel Dual Quad core at a minimum of 3GHz
- 8 GB RAM
- Dual Layer DVD-RW
- 250 GB HD
- 25 LCD display, supporting a minimum 32bit high color at 1440x900 resolution.
- 1000MB Ethernet Network Interface Card
- Standard 101-key keyboard and 2-button wheel mouse

- 4 Your scope mentions having the ability to include up to a maximum of 17 cameras and 10 additional doors on the system.

This has been modified to include 21 door locations currently and ability to expand to include 10 more doors.

I understood at the pre-bid meeting that we are quoting an access control system for 17 doors with 17 cameras and have the ability to add 10 more cameras and 10 more doors to the system. Could you clarify this?

The system has been modified to now include 21 total door locations and bidding of 21 potential cameras to be added to the system. The system must be capable of expanding to handle an additional 10 doors and cameras.

Also mentioned was the integration of the cameras into the access control system. Could you clarify as to what you expect to see in this integration? Usually the camera system is view with it's own browsers, however we can integrate them into the access control so that when an event occurs, they will pop up in the access control to be viewed and trigger the DVR to record at a higher rate or "bookmark" that part of the video.

We would like the camera system to function in the above stated manner described by the vendor. It can be used as a monitoring system at all times, but can also trigger attention when an event happens at a location.

- 5 Due to the nature of the project and it's funding will a Bid Bond and Performance & Payment Bond be a requirement for this project?

No

Are there set terms regarding the frequency of the submission of Pay Requests ie: bi-weekly, monthly? Will there be retainage held from each pay request? If so, what percentage?

The vendor may bill the hospital for work completed on a monthly basis. Before payment will be issued, a walk through will be performed to ensure that work is completed to the specifications required.

- 6 In addition, will Certified Payroll Forms be required to be submitted? If so, with what frequency shall they be submitted over the 120 calendar day substantial completion period

No

7. The fire alarm panel will be providing us a dry contact to shut down the magnetic locks to release the doors. The question I have is will we have to interpose the magnetic lock power with a wire that has to be home run from each door back to the fire alarm panel, or will we be able to accept the contact directly into our access control system and allow it to disable the magnetic locks through programming when this happens? The Fire Marshal will probably have to address this question

The vendor can use a local devise signal that is activated by the fire alarm system or a signal from the fire alarm panel. The manner this is achieved must meet all Fire Marshal requirements.

8. Since this system is going to consist of 17 cameras that need to come back to a DVR, this will present a problem since most DVR's handle up to 16 cameras when doing an analog camera system which will require the use of two DVR's and possibly present a problem for some vendors to integrate into one screen. If you were doing IP camera's this would not be an issue and could provide smoother integration with the access control system. I understand the reason for steering away from IP Video is due to bandwidth on the

network I believe the best solution is to use IP, but install our own Switches, converters and run our cables back to the existing equipment room racks and set up our own network for the camera and access control system and then allow your people to access our network from your network to monitor and administer the access control and CCTV system/Network Video Recorder. Please consider and modify specifications accordingly

The system has been modified to include 21 locations currently and we are not able to support IP video cameras. The video cameras are an additional feature, multiple options may be submitted to support cameras that meet the above stated specifications.

- 9 Are there any fiber optic cable runs between the various equipment room rack closets now and if so are there any spare fibers available and if so, is the fiber multi-mode or single mode?

Yes, there are fiber drops to the closets.

Yes, there are spare fiber pairs.

Multi-mode

Clarification and Corrections to the RFQ:

1. Modification to include 21 doors at the facility. There are 9 single doors and 12 double doors, to make up the 21 total locations.
2. The bid for this system is to include only the access control system without video cameras. The vendors are asked to provide a system that can be updated to include 21 video cameras and provide a cost per camera that meets the above stated specs
3. The system is to include 1,200 pound magnetic locks on all 21 door locations.
4. The work performed during installation, during maintenance and the completed installation of the product will be done in a manner that comply with all applicable State and Federal rules, regulations and guidelines, including but not limited to NFPA, National Electrical Code, OSHA.
5. After discussion with the Fire Marshall, panic bars are to be set up with a 30 second open delay and must include an alarm that signals an attempt to use the door. The vendor must also provide a NFPA approved sign at each location stating the operation of the mechanism.

Computer Network

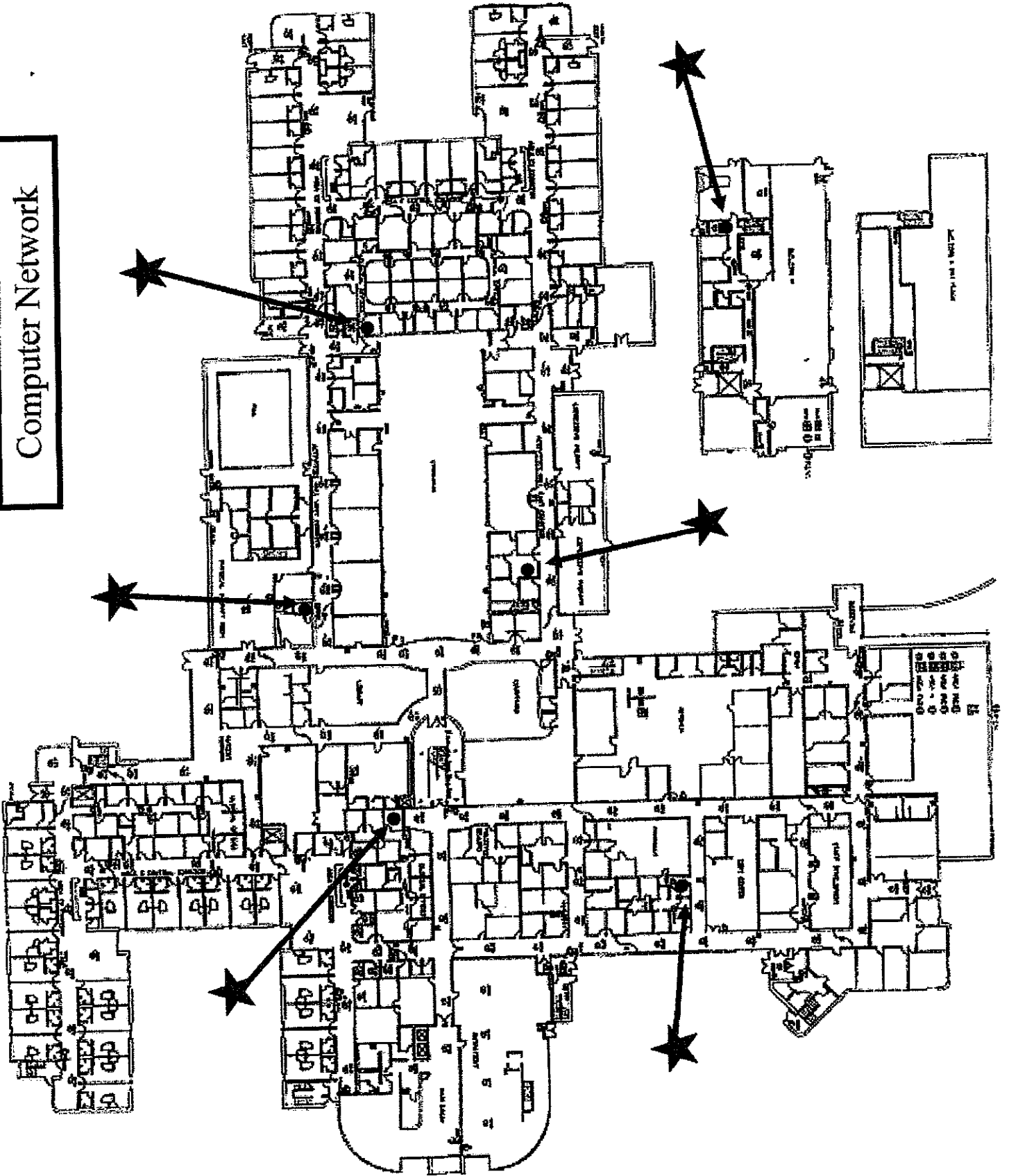

Ceiling Type

- Interlocking Tiles
- Wood Slat
- Drop in Tiles

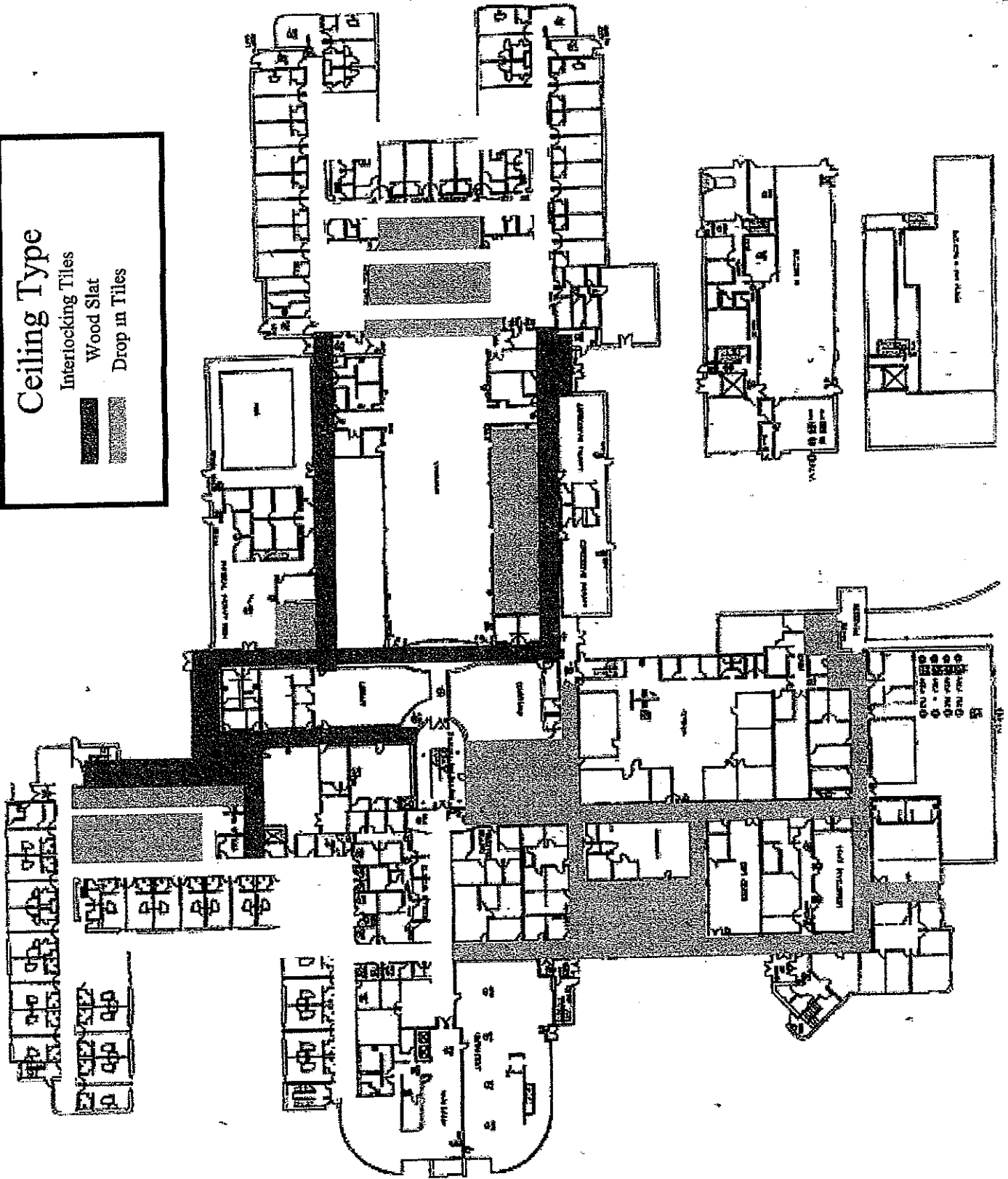

Door Locations

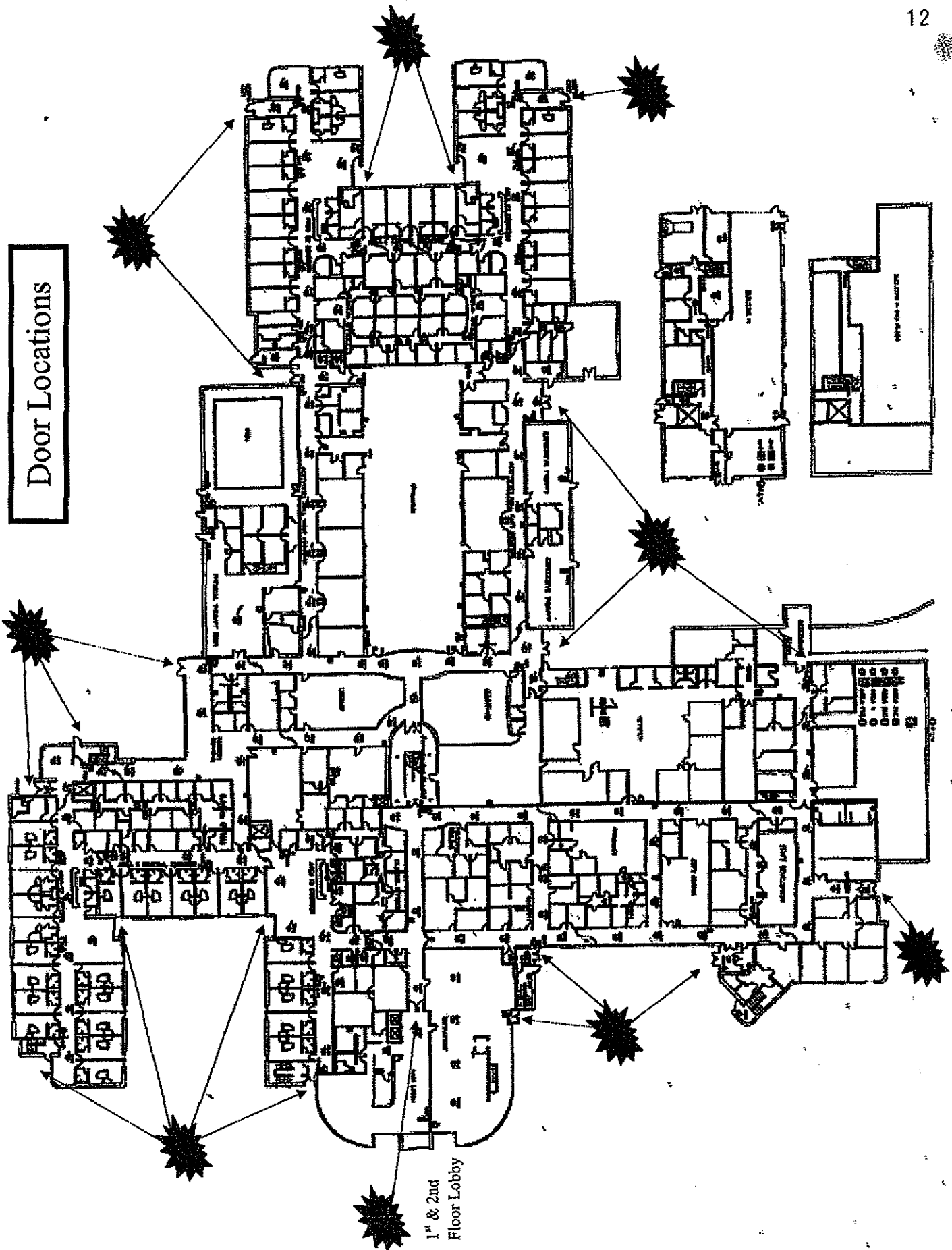



State of West Virginia
 Department of Administration
 Purchasing Division
 2019 Washington Street East
 Post Office Box 50130
 Charleston, WV 25305-0130

Request for Quotation

RFQ NUMBER
 WSH10002

PAGE
 1

ADDRESS CORRESPONDENCE TO ATTENTION OF
 ROBERTA WAGNER
 804-558-0067

RFQ COPY

TYPE NAME/ADDRESS HERE

VENDOR

Mountain State Building Automation
 6444 Sissonville Dr
 Sissonville, WV 25320

SHIP TO

HEALTH AND HUMAN RESOURCES
 WILLIAM R. SHARPE JR. HOSPITAL
 CENTRAL RECEIVING
 936 SHARPE HOSPITAL ROAD
 WESTON, WV 26452
 304-269-1210

DATE PRINTED	TERMS OF SALE	SHIP VIA	F.O.B.	FREIGHT TERMS
08/04/2009				

BID OPENING DATE: 08/20/2009 BID OPENING TIME 01:30PM

LINE	QUANTITY	UOP	CAT NO	ITEM NUMBER	UNIT PRICE	AMOUNT
ADDENDUM NO. 3 1. TO MOVE THE BID OPENING DATE FROM 8/18/2009 TO 8/20/2009. 2. ADDENDUM ACKNOWLEDGEMENT IS ATTACHED. THIS DOCUMENT SHOULD BE SIGNED AND RETURNED WITH YOUR BID. FAILURE TO SIGN AND RETURN MAY RESULT IN DISQUALIFICATION OF YOUR BID. EXHIBIT 10 REQUISITION NO.: WSH10002 ADDENDUM ACKNOWLEDGEMENT I HEREBY ACKNOWLEDGE RECEIPT OF THE FOLLOWING CHECKED ADDENDUM(S) AND HAVE MADE THE NECESSARY REVISIONS TO MY PROPOSAL, PLANS AND/OR SPECIFICATION, ETC. ADDENDUM NO. S: NO. 1 CEC 8/19/09 NO. 2 CEC 8/19/09 NO. 3 CEC 8/19/09 NO. 4 NO. 5 I UNDERSTAND THAT FAILURE TO CONFIRM THE RECEIPT OF TH						

SEE REVERSE SIDE FOR TERMS AND CONDITIONS

SIGNATURE <i>[Signature]</i>	TELEPHONE (304) 984-0415	DATE 8/19/09
TITLE Vice President	FEN 26-3312652	ADDRESS CHANGES TO BE NOTED ABOVE

WHEN RESPONDING TO RFQ, INSERT NAME AND ADDRESS IN SPACE ABOVE LABELED 'VENDOR'

**GENERAL TERMS & CONDITIONS
REQUEST FOR QUOTATION (RFQ) AND REQUEST FOR PROPOSAL (RFP)**

1. Awards will be made in the best interest of the State of West Virginia
2. The State may accept or reject in part, or in whole, any bid
3. All quotations are governed by the *West Virginia Code* and the *Legislative Rules* of the Purchasing Division
4. Prior to any award, the apparent successful vendor must be properly registered with the Purchasing Division and have paid the required \$125 fee
5. All services performed or goods delivered under State Purchase Order/Contracts are to be continued for the term of the Purchase Order/Contracts, contingent upon funds being appropriated by the Legislature or otherwise being made available. In the event funds are not appropriated or otherwise available for these services or goods, this Purchase Order/Contract becomes void and of no effect after June 30
6. Payment may only be made after the delivery and acceptance of goods or services
7. Interest may be paid for late payment in accordance with the *West Virginia Code*
8. Vendor preference will be granted upon written request in accordance with the *West Virginia Code*
9. The State of West Virginia is exempt from federal and state taxes and will not pay or reimburse such taxes
10. The Director of Purchasing may cancel any Purchase Order/Contract upon 30 days written notice to the seller.
11. The laws of the State of West Virginia and the *Legislative Rules* of the Purchasing Division shall govern all rights and duties under the Contract, including without limitation the validity of this Purchase Order/Contract
12. Any reference to automatic renewal is hereby deleted. The Contract may be renewed only upon mutual written agreement of the parties
13. **BANKRUPTCY:** In the event the vendor/contractor files for bankruptcy protection, the State may deem this contract null and void, and terminate such contract without further order
14. **HIPAA BUSINESS ASSOCIATE ADDENDUM:** The West Virginia State Government HIPAA Business Associate Addendum (BAA), approved by the Attorney General, and available online at the Purchasing Division's web site (<http://www.state.wv.us/admin/purchase/vrc/hipaa.htm>) is hereby made part of the agreement. Provided that, the Agency meets the definition of a Cover Entity (45 CFR §160.103) and will be disclosing Protected Health Information (45 CFR §160.103) to the vendor
15. **WEST VIRGINIA ALCOHOL & DRUG-FREE WORKPLACE ACT:** If this Contract constitutes a public improvement construction contract as set forth in Article 1D, Chapter 21 of the West Virginia Code ("The West Virginia Alcohol and Drug-Free Workplace Act"), then the following language shall hereby become part of this Contract: "The contractor and its subcontractors shall implement and maintain a written drug-free workplace policy in compliance with the West Virginia Alcohol and Drug-Free Workplace Act, as set forth in Article 1D, Chapter 21 of the West Virginia Code. The contractor and its subcontractors shall provide a sworn statement in writing, under the penalties of perjury, that they maintain a valid drug-free work place policy in compliance with the West Virginia and Drug-Free Workplace Act. It is understood and agreed that this Contract shall be cancelled by the awarding authority if the Contractor: 1) Fails to implement its drug-free workplace policy; 2) Fails to provide information regarding implementation of the contractor's drug-free workplace policy at the request of the public authority; or 3) Provides to the public authority false information regarding the contractor's drug-free workplace policy "

INSTRUCTIONS TO BIDDERS

1. Use the quotation forms provided by the Purchasing Division
2. **SPECIFICATIONS:** Items offered must be in compliance with the specifications. Any deviation from the specifications must be clearly indicated by the bidder. Alternates offered by the bidder as **EQUAL** to the specifications must be clearly defined. A bidder offering an alternate should attach complete specifications and literature to the bid. The Purchasing Division may waive minor deviations to specifications.
3. Complete all sections of the quotation form
4. Unit prices shall prevail in case of discrepancy.
5. All quotations are considered FOB destination unless alternate shipping terms are clearly identified in the quotation
6. **BID SUBMISSION:** All quotations must be delivered by the bidder to the office listed below prior to the date and time of the bid opening. Failure of the bidder to deliver the quotations on time will result in bid disqualifications: Department of Administration, Purchasing Division, 2019 Washington Street East, P.O. Box 50130, Charleston, WV 25305-0130



State of West Virginia
 Department of Administration
 Purchasing Division
 2019 Washington Street East
 Post Office Box 50130
 Charleston, WV 25305-0130

Request for Quotation

RFQ NUMBER
 WSH10002

PAGE
 2

ADDRESS CORRESPONDENCE TO ATTENTION OF
 ROBERTA WAGNER
 304-558-0067

RFQ COPY

TYPE NAME/ADDRESS HERE
 Mountain State Building Automation
 6444 Sissonville Dr
 Sissonville, WV 25320

SHIP TO

HEALTH AND HUMAN RESOURCES
 WILLIAM R. SHARPE JR. HOSPITAL
 CENTRAL RECEIVING
 936 SHARPE HOSPITAL ROAD
 WESTON, WV
 26452 304-269-1210

DATE PRINTED	TERMS OF SALE	SHIP VIA	F.O.B.	FREIGHT TERMS
08/04/2009				

BID OPENING DATE: 08/20/2009 BID OPENING TIME 01:30PM

LINE	QUANTITY	UOP	CAT NO	ITEM NUMBER	UNIT PRICE	AMOUNT
<p>ADDENDUM(S) MAY BE CAUSE FOR REJECTION OF BIDS.</p> <p>VENDOR MUST CLEARLY UNDERSTAND THAT ANY VERBAL REPRESENTATION MADE OR ASSUMED TO BE MADE DURING ANY ORAL DISCUSSION HELD BETWEEN VENDOR'S REPRESENTATIVES AND ANY STATE PERSONNEL IS NOT BINDING. ONLY THE INFORMATION ISSUED IN WRITING AND ADDED TO THE SPECIFICATIONS BY AN OFFICIAL ADDENDUM IS BINDING.</p> <p style="text-align: center;"> SIGNATURE Mountain State Building Automation COMPANY 8/19/09 DATE </p> <p>REV 11/96</p> <p style="text-align: center;">END OF ADDENDUM NO. 3</p>						

SEE REVERSE SIDE FOR TERMS AND CONDITIONS			
SIGNATURE	TELEPHONE (304) 984-0415	DATE 8/19/09	
TITLE Vice President	FEIN 26-3312652	ADDRESS CHANGES TO BE NOTED ABOVE	

WHEN RESPONDING TO RFQ, INSERT NAME AND ADDRESS IN SPACE ABOVE LABELED 'VENDOR'



State of West Virginia
 Department of Administration
 Purchasing Division
 2019 Washington Street East
 Post Office Box 50130
 Charleston, WV 25305-0130

Request for Quotation

RFQ NUMBER
 WSH10002

PAGE
 3

ADDRESS CORRESPONDENCE TO ATTENTION OF:
 ROBERTA WAGNER
 304-558-0067

RFQ COPY
 TYPE NAME/ADDRESS HERE
 Mountain State Building Automation
 6444 Sissonville Dr
 Sissonville, WV 25320

SHIP TO
 HEALTH AND HUMAN RESOURCES
 WILLIAM R. SHARPE JR. HOSPITAL
 CENTRAL RECEIVING
 936 SHARPE HOSPITAL ROAD
 WESTON, WV
 26452 304-269-1210

DATE PRINTED	TERMS OF SALE	SHIP VIA	F.O.B.	FREIGHT TERMS
08/04/2009				

BID OPENING DATE: 08/20/2009 BID OPENING TIME 01:30PM

LINE	QUANTITY	UOP	CAT NO	ITEM NUMBER	UNIT PRICE	AMOUNT
0001	1	JB		990-22		\$83,650
				ACCESS CONTROL SECURITY SYSTEM		
***** THIS IS THE END OF RFQ WSH10002 ***** TOTAL:						\$83,650

SEE REVERSE SIDE FOR TERMS AND CONDITIONS

SIGNATURE *C. C. ...* TELEPHONE (304) 984-0415 DATE 8/19/09
 TITLE Vice President FEIN 26-3312652 ADDRESS CHANGES TO BE NOTED ABOVE

WHEN RESPONDING TO RFQ, INSERT NAME AND ADDRESS IN SPACE ABOVE LABELED 'VENDOR'



Security Management System *Enterprise Software*

Overview

The Schlage Security Management System delivers a powerful, single source solution for integrating a facility's access-control technologies, digital video, and alarm monitoring systems. Four software levels are provided to meet your current security requirements and can expand to meet your growing business needs, while satisfying your budget constraints.

The Enterprise system is perfect for large, multi-site or global organizations. It supports an unlimited number of cardholders and readers and gives you unparalleled flexibility. The Enterprise system also enables an organization to manage facility administration from any location and provides real-time monitoring and audit trails.

FEATURES & BENEFITS

Access Control Features

- Anti-passback
- Two-man rule and occupancy rule
- First card in capability
- Temporary usage badges
- Reliability and power of MS SQL available
- Portrait monitoring
- Unlimited reports

(continued)

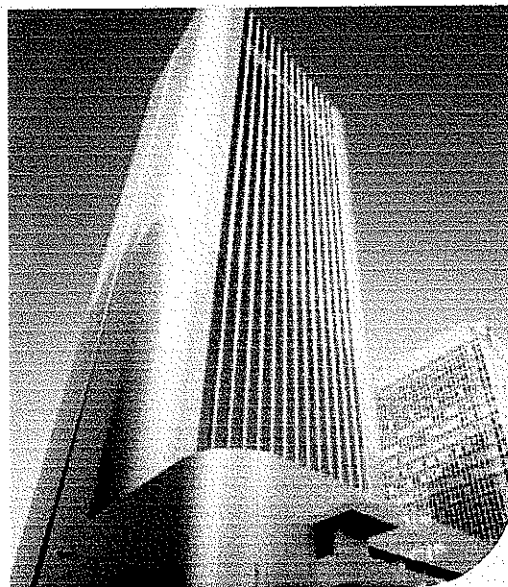

ORDERING INFORMATION

Software Only

- SENT-SFT-1 - Enterprise software with 1 license
- SENT-SFT-5 - Enterprise software with 5 client licenses
- SENT-SFT-10 - Enterprise software with 10 client licenses
- SENT-SFT-25 - Enterprise software with 25 client licenses
- SENT-SFT-EXP - 1 client expansion license (for greater than 25 licenses)

Software & Server

- SENT-SVR-1 - Includes server, monitor, keyboard, mouse and software with 1 license
- SENT-SVR-5 - Includes server, monitor, keyboard and mouse sold separately and software with 5 client licenses
- SENT-SVR-10 - Includes server, monitor, keyboard and mouse sold separately and software with 10 client licenses
- SENT-SVR-25 - Includes server, monitor, keyboard and mouse sold separately and software with 25 client licenses

Servers are also available in rack mount versions. Call factory for details.

FEATURES & BENEFITS *(continued)*

- Report scheduling
- ODBC Compliant
- Operates in Windows 2000, 2003 XP Pro environments
- Online and offline lock integration
- Manual and automatic overrides
- Full-featured Guest Pass system
- Security guard touring
- Design and print badges
- Programmable flash for downloads and firmware updates
- Wireless reader devices
- Unlimited holidays
- Unlimited cardholders and readers
- Unlimited number of concurrent users available
- Unlimited time zones
- Universal triggers
- Muster reporting

Alarm Management Features

- Color coded Alarms
- User-definable individual alarm instructions
- Pre-defined responses
- Send alarms to operator or email
- Keypad duress alarm
- Alarm annunciation
- Alarm graphics

Video Features (See SVSU and SEVMS datasheets for specifications)

- Full integration with Schlage DVRs
- High resolution video motion detection with masking capabilities
- Search on video motion detection
- Uninterrupted recording during playback and image archiving
- Remote viewing
- Send video clips via email
- Customizable pre and post-recording upon an event
- Proprietary viewer software for viewing encrypted files
- Scalable
- 100% date/time synchronization
- Full PTZ functionality
- Virtual camera grouping across servers
- Advanced security permissions
- Database backup and recovery
- Audio per camera available
- Web-based option
- Optional intelligent video and Mobile DVR
- Accepts analog/digital or IP addressable cameras

Usability Features

- Configuration wizards
- Easy-to-navigate
- Customizable views per operator
- Unlimited User-defined fields



Schlage

Electronic Security
575 Birch Street
Forestville, CT 06010 USA
Tel 860-584-9158/866-322-1237
Fax 860-584-2136/866-322-1233
Tel 800-950-4573 (Toll Free Canada)
www.schlage.com



Security Management System *Model SRCNX* Reader Controller

Overview

The Schlage Reader Controller (SRCNX) is an intelligent device that can be paired with any one of the Schlage Security Management System software packages. The number of controllers and downstream devices are unlimited. The SRCNX series is capable of making all the decisions at a local level and storing history in the event that communication is lost with the server.

The SRCNX series (SRCNX-2, SRCNX-8 and SRCNX-16) can be configured to fit any application. The communication architecture is capable of being fully networked (TCP/IP LAN/WAN) saving the customer wiring and expensive installation labor costs. The SRCNX Series has the flexibility of also communicating through dial up modem when a network is not available.

The SRCNX series controllers communicate to the downstream devices via RS-485 (for RS-232 configuration call factory). The SRCNX series controllers support direct connection for the following devices; SRINX, SIONX-24, Schlage VIP Locks, Schlage Wireless PIM-485 module (supports 15 Schlage Wireless readers), and additional SRCNX units. The Schlage Reader Interfaces (SRINX) will support a variety of read heads technologies in any combination of Biometrics devices, Smartcard, Proximity, Magnetic Stripe, Weigand, Barium Ferrite, Bar code and Keypad.

Note: See configuration guides for specific configuration rules.

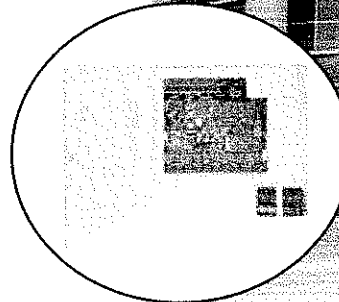

ORDERING INFORMATION:

SRCNX-2 - Includes two (2) Reader Interfaces (SRINX) mounted in 20" x 20" enclosure.

SRCNX-8 - Mounted in 20" x 20" enclosure, Order reader interfaces (SRINX) separately.

SRCNX-16 - Mounted in 20" x 20" enclosure, Order reader interfaces (SRINX) separately.

Note: SRCNX-8 and SRCNX-16 can be ordered without individual enclosures. Use (NB) to specify no box. For use with custom enclosures.

FEATURES & BENEFITS

- 16 input device channels
- 8 contact inputs with dynamic current sourcing. Ideal for replacing 3rd party alarm/access panels.
- Supports majority of end-of-line resistor valves
- 2 two amp relays SP/DT
- Dynamically allocated memory
- Flashable Firmware
- Super Cap – keeps on board memory intact in case of power failure
- 1 MB RAM for ID capability

SPECIFICATIONS:

- SRCNX Reader Controller board dimensions: 9-3/4"H x 13-1/2"W x 1-1/2"D
- Standard SRCNX Series Enclosure (lockable) Dimensions: 20"H x 20"W x 4"D
- Power requirements: 16 VAC at 4 amps or 24 VDC at 4 amps

OPTIONS:

- SIONX - Input/Output Expansion Board
Snaps on the SRCNX and provides 8 NO/NC supervised or unsupervised inputs, 12 2 AMP relays. Dimensions: 11" x 3"
- SIONX-24 - Input/Output Expansion Board
Provides 24 NO/NC supervised or unsupervised inputs, 24 2 AMP relays. Includes lockable enclosure.
- SMODNX - Snaps on the SRCNX and provides Dial up modem capability. Dimensions: 5-1/4" x 2"
- SIPNX-100 - IP Addressable Module snaps on the SRCNX and provides Ethernet connection. Dimensions: 5-1/4" x 2"
- Fiber Converters- Consult factory for individual application
- See available custom enclosures



Schlage

Electronic Security
575 Birch Street
Forestville, CT 06010 USA
Tel 860-584-9158/866-322-1237
Fax 860-584-2136/866-322-1233
Tel 800-950-4573 (Toll Free Canada)
www.schlage.com



Security Management System

Model SRINX

Reader Interface

Overview

The SRINX offers a cost effective, modular approach to access control system design for industrial environments. Schlage Reader Interfaces can be used in the small systems as well as large installations with thousands of readers. The SRINX Reader Interface is supported by the entire family of Schlage reader controllers. Compatible with various read head technologies: proximity, magnetic stripe, bar code, Wiegand, barium ferrite, smart card, biometric, wireless, etc. Schlage SRINX Reader Interfaces can run in degraded mode allowing for local decision making if communication fails between the SRINX and the Reader Controller (SRCNX).

FEATURES & BENEFITS

- SRINX connects 1 read head to the reader controller (SRCNX) via RS-485
- Supports multiple read head technologies: magnetic stripe, bar code, Wiegand, barium ferrite, smart card, proximity, and biometric, wireless, etc.
- Form "C", single pole/double throw, mechanically latching 2 AMP relays (see ordering info)
- Seven supervised or unsupervised contact inputs with ability to support a wide range of end-of-line resistor values
- Connection for one multicolor LED for GO or NO/GO indication
- Connection for one buzzer
- Ideal for replacing third party access/alarm panels



SPECIFICATIONS

- Dimensions: 3-3/16" H x 3-3/16" W x 1-3/4" D
- Enclosure: 8-1/4" H x 7-1/2" W x 3-1/2" D
- Power requirements: 12VAC/12VDC (can be powered from SRCNX)
- Power consumption: 100mA (without read heads)
- Ambient temperature: 0° to 70° C or -40° to 185° F
- Humidity: 10% to 90% (non-condensing)
- Maximum distance from SRCNX: 4,000 feet, RS485 data communication (RS-232 communication available)
- Recommended cable: 22 AWG/4 COND, stranded, shielded, twisted

ORDERING INFORMATION:

- SRINX-1 - Provides for 1 card reader. Seven contact inputs and one Form "C" 2 AMP relay.
- SRINX-2 - Provides for 1 card reader. Seven contact inputs and two Form "C" 2 AMP relay.

Value Priced Proximity Card Reader • 6005

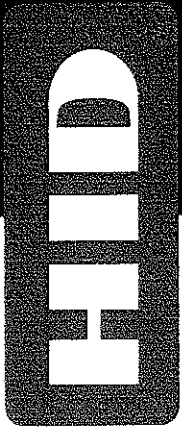
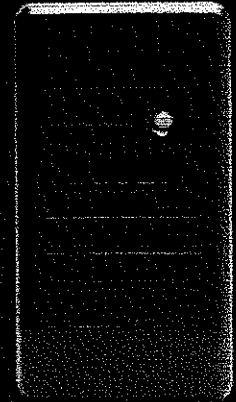

ACCESS reliability.

Application

HID's ProxPoint[®] Plus reader combines multiple configuration options for an attractive, inconspicuous design and economical price. Its secure, potted electronics are ideal for both indoor and outdoor applications.

Features

- » Features a beeper and multicolor LED which can be host and/or locally controlled.
- » Enables various beeper and LED configurations depending on individual site requirements.
- » Can read HID cards with formats up to 85 bits.
- » Designed for mounting directly onto metal with no change in read range performance.
- » Available with either Wiegand or Clock-and-Data (magnetic stripe data) output.
- » Compatible with all standard access control systems.
- » Aesthetic design available in two color designs and in four colors to match any decor.
- » Includes multilingual installation manual.

Mounting Unobtrusive design can be mounted directly onto metal such as door Mullions.

Audiovisual Indication Audiovisual indications when a proximity card is presented to the reader, the red LED flashes green and the beeper sounds. The multicolor LED and beeper can also be controlled individually by the host system.

Diagnostics On reader power-up, an internal self-test routine checks and verifies the setup configuration, determines the internal or external control of the LED and beeper, and initializes reader operation. An additional external loop back test allows for the reader outputs and inputs to be verified without the use of additional test equipment.

Indoor/outdoor Design Sealed in a rugged, weatherized polycarbonate enclosure designed to withstand harsh environments, providing reliable performance and a high degree of vandal resistance.

Easily Interfaced Wiegand output model interfaces with all existing Wiegand protocol access control systems. Clock-and-Data (magnetic stripe) model interfaces with most systems that accept magnetic stripe readers.

Security Recognizes card formats up to 65 bits, with over 137 billion unique codes.

Warranty Lifetime warranty against defects in materials and workmanship (see complete sales policy for details).

Part Numbers Base Part No.: 6005B Wiegand Interface
Base Part No.: 6008B Clock-and-Data Interface

Description Tri-State LED, Digital Connection.

- Options**
- CLASSIC series cover in grey, beige, black, or white (not)
 - Designer series cover in grey, wave blue, black, or white
 - custom label
 - custom embossing in housing

(Please see "How to Order Guide" for a description of options and associated part numbers.)

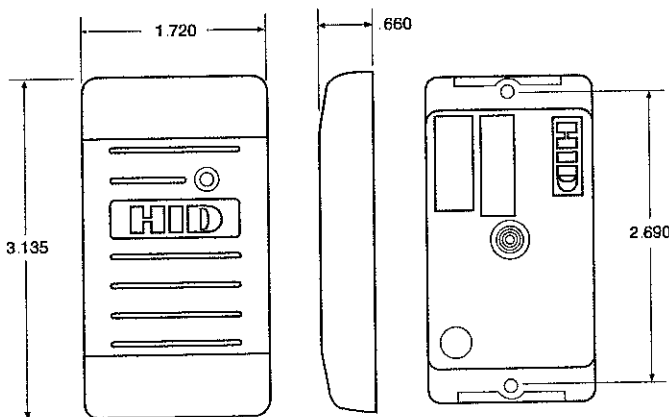

Typical Maximum* Read Range

- ProxCard® II card - up to 3" (7.6 cm)
 - ISOProx® II card - up to 2.5" (6.35 cm)
 - DuoProx® II card - up to 2.5" (6.35 cm)
 - Smart ISOProx®/DuoProx® II cards - up to 2.5" (6.35 cm)
 - Proximity & MIFARE® card - up to 1.5" (3.8 cm)
 - ProxCard® Plus card - up to 1.0" (2.5 cm)
 - ProxKey® II keyfob - up to 1.5" (3.8 cm)
 - MicroProx® Tag - up to 2" (5.1 cm)
- * Depending on local installation conditions.

Dimensions

3.135" x 1.720" x 0.660 (7.96 x 4.37 x 1.68 cm)

Material: Polycarbonate UL 94

Power Supply

5-16 VDC
Linear power supplies are recommended.

Maximum Current Requirements

Current (DC)
Average 30 mA, Peak 75 mA

Operating Temperature

-22° to 150° F (-30° to 65° C)

Operating Humidity

0-95% relative humidity non-condensing

Transmit Frequency: 125 kHz

Weight: 2.7 oz (75 gm)

Environmental: IP55

Certifications

UL294/cUL (US), FCC Certification (US), IC (Canada), CE (EU), C-tick (Australia, New Zealand), SPRC (China), MIC (Korea), NCC (Taiwan), MIC (Japan), iDA (Singapore), RoHS

Cable Distance

Wiegand or Clock-and-Data interface
500 feet (150 m)
Recommended cable is ALPHA 1295 (22 AWG) 2 conductor stranded with overall shield or equivalent.

HID Global is a leading provider of access control solutions. We are proud to be a member of the ASSA ABLOY Group. For more information, please visit our website at www.hidglobal.com. We are committed to providing the highest quality products and services to our customers.

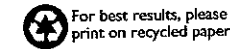

© 2008 HID GLOBAL, INC.

hidglobal.com



ACCESS experience.

HID Global Offices

Corporate North America
10200 Woodloch Way
Houston, TX 77036
Phone: (800) 377-7745
Phone: (281) 737-2000
Fax: (281) 737-2100

Asia Pacific
2701 The Woodlands
North King
San Jose, CA
Phone: (408) 436-8800
Fax: (408) 436-8800

Latin America
Avenida San Pablo #4016B
Dorado
Caribbean, Puerto Rico
Phone: (787) 461-0000
Mexico
Hidalgo #2477-70-1412
C.P. 52100-1001

Europe, Middle East & Africa
Hewlett Business Park
Hewlett Road
Hewlett
New York, NY
Phone: (408) 436-8800
Fax: (408) 436-8800

125 kHz Proximity Tag with Adhesive Back • 1391

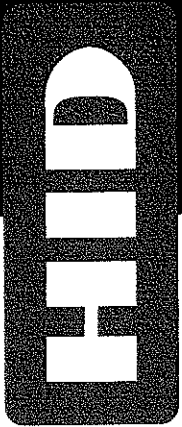
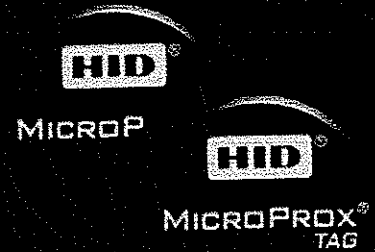

ACCESS reliability.

Application

The MicroProx[®] Tag provides the convenience of HID's proximity technology in a small disk-shaped transponder. Simply attach the adhesive-backed Tag to any nonmetallic card or device, and you instantly have a proximity card!

With the MicroProx Tag you can:

- » Seamlessly upgrade from Wiegand, magnetic stripe or barium ferrite technologies by simply adhering the Tag to your existing access card.
- » Easily and cost-effectively turn a plastic ID badge or contact smart chip card into a proximity credential!
- » Add proximity access control capability to users' cell phones, PDAs and other similar nonmetallic devices.

Experience the convenience of proximity without the expense of rebadging!

Features

- » Offers consistent read range and reliable operation.
- » The size of a coin, the Tag easily attaches to all nonmetallic materials.
- » The Tag can be programmed in any HID proximity format, and is compatible with all HID proximity readers.
- » The Tag is RF-programmable for ease of encoding with HID's ProxProgrammer[®].

- Description** RF programmable 125 kHz customer specified numbers.
- Proven, Reliable Technology** Offers extremely consistent read range. Unaffected by body shielding or variable environmental conditions even when close to keys and coins.
- Security** Over 1.9x10²⁵ unique codes available.
- Long Life** Passive no-battery design allows for an infinite number of reads.
- Warranty** Warranted against defects in materials and workmanship for two years from date of shipment (See warranty policy for details.)

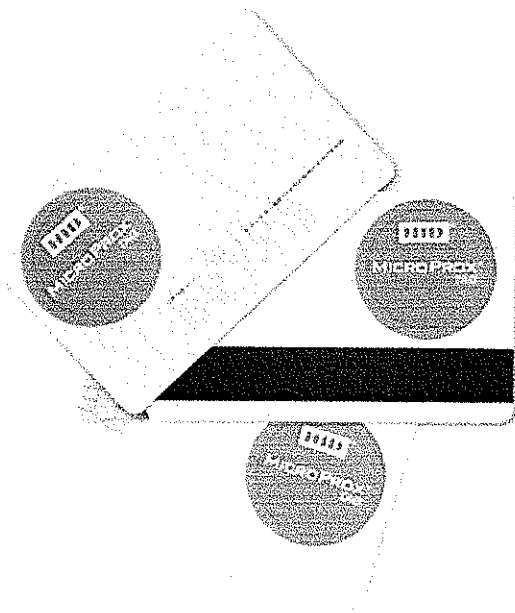

Sample placement shown - actual placement will depend on application. Due to variations in cards and reading devices HID does not claim that the MicroProx Tag will work in every situation. Functional and non-functional MicroProx Tags are available for compatibility testing with existing credential and reader technologies. Compatibility should be confirmed prior to ordering.

- Typical Maximum* Read Range**
 ProxPoint[®] Plus reader up to 2'0" (5.1 cm)
 MiniProx[®] reader up to 2'25" (5.7 cm)
 ThinLine[®] II reader up to 2'5" (6.4 cm)
 Prox80[™] reader up to 2'25" (5.7 cm)
 ProxPro[®] II reader up to 3'5" (8.9 cm)
 ProxPro[®] reader up to 4' (10.2 cm)
 MaxiProx[®] reader up to 4'5" (11.4 cm)
 *Depending on local installation conditions.

Data Storage
Up to 84 bits (Over 1.9x10²⁵ codes)

Dimensions
Diameter: 1.285" (32.64 cm)
Thickness: 0.070" (0.178 cm)

Outer Shell Material
Lexan

Operating Temperature
-50° to 160° F (-45° to 70° C)

Weight
0.04 oz (1.18 g)

Part Number
Base Part No: 1391

Options
Color - black or gray

(Please see How to Order Guide for a description of the options and associated part numbers.)

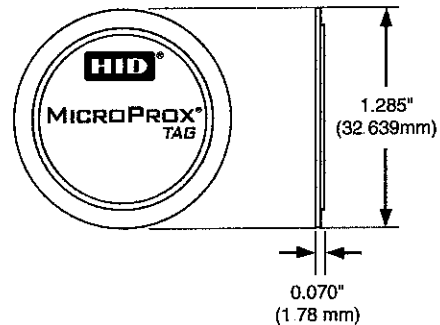

© 2007 HID Global. All rights reserved. HID and the HID logo are trademarks or registered trademarks of HID Global in the U.S. and/or other countries. All other trademarks, service marks, and product or service names are trademarks or registered trademarks of their respective owners. Rev. 4.2607

For best results, please print on recycled paper

MKT-MICROPROX_DS_EN



ACCESS experience.

hidcorp.com

HID Global Offices

Corporate
North America
 2292 Jeronimo Road
 Irvine, CA 92618-1905
 USA
 Phone: (949) 237-7767
 Phone: (949) 598-1600
 Fax: (949) 598-1690

Asia Pacific
 1915 645 Kings Road
 North Point
 Island East
 Hong Kong
 Phone: +852 3160-9800
 Fax: +852 3160-4809

Latin America
 Circunvalación Cte. #201 B
 Despacho 2
 Col. Jardines del Moral
 Feon 37140 Cto.
 Mexico
 Phone: +52 477 779 1492
 Fax: +52 477 779 1493

Europe, Middle East, & Africa
 Homefield Road
 Havering, Suffolk
 CB9 80J
 England
 Phone: +44 (0) 1440 714 850
 Fax: +44 (0) 1440 714 840

**ROFU® MAGNETIC DOOR LOCKING DEVICE
MODEL 8011-004 Delayed Egress Locking System**

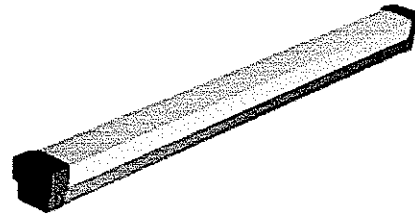
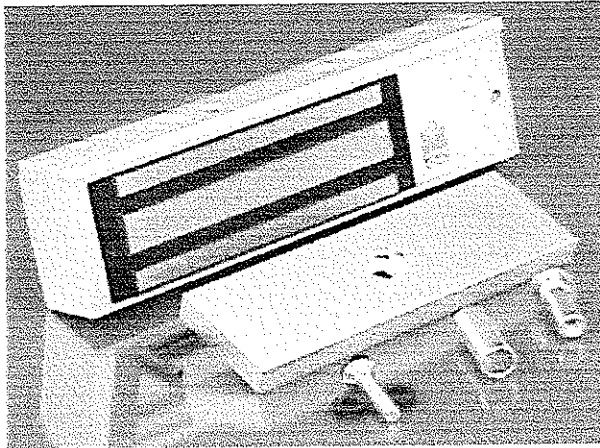

THE ROFU 8011-004 Delayed Egress System

- Fully complies with NFPA Life Safety Code 101.
- UL Listed #SA13496, Special Locking Arrangement
- State of the art microprocessor technology
- Combines life safety, security and cost effectiveness
- Ideal for single or multiple door installations
- Ideal for retrofit as well as new installations
- Installer friendly! comes complete with the ROFU #9500 micro -switch bar and a ROFU #10318 door cord.

STANDARD FEATURES

- Self contained system
- Built in Piezo Alarm at 85db
- 12 VDC output for remote alarm
- Fire Alarm contact
- Anti Tamper Alarm
- Reset contact for keyswitch or remote resetting
- Relay for remote monitoring
- Bond Sensing circuit
- Built in watch dog circuit to check system's operation
- Adjustable Nuisance Time Delay to prevent false alarms
- 15 second egress delay
- Two reset methods
- Automatic Malfunction Alarm and release
- Low current draw of 225mA at 12VDC
- For Dimensions see ROFU 8011-002 Series

SPECIFICATIONS	
Magnet Size:	10-1/2" x 2-5/8" x 1-5/8" (LxHxW)

Armature Size:	7-1/4" x 2-3/8" x 5/8" (LxHxW)
Finish:	US28 - Aluminum



Made in the USA



AL1024ULACM, AL1024ULACMCB Power Supply/Chargers w/Multi-Output Access Power Controllers

Rev DSAL1024ULACM - A06F

Overview

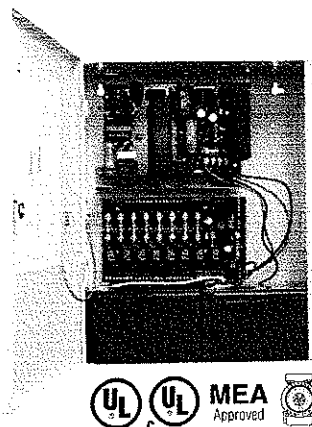

- The AL1024ULACM / AL1024ULACMCB converts an 115VAC 60Hz input into eight (8) independently controlled 24VDC Fail-Safe and/or Fail-Secure outputs with a total of 10 amp continuous supply current. Outputs are activated by an open collector sink or normally open (NO) dry trigger input from an Access Control System, Card Reader, Keypad, Push Button, PIR, etc. These units will route power to a variety of access control hardware devices including Mag Locks, Electric Strikes, Magnetic Door Holders, etc. The outputs will operate in both Fail-Safe and/or Fail-Secure modes. The units are designed to be powered by one common power source (factory installed) which will provide power for both the board operation and locking devices, or two (2) totally independent power sources, one (1) providing power for board operation and the other for lock / accessory power. The FACP Interface enables Emergency Egress, Alarm Monitoring, or may be used to trigger other auxiliary devices. The fire alarm disconnect feature is individually selectable for any or all of the eight (8) outputs.

AL1024ULACM

- Eight (8) independently controlled fuse protected outputs.

AL1024ULACMCB

- Eight (8) independently controlled PTC protected outputs.
- Class 2 Rated power limited outputs.

Specifications

- 24VDC @ 10 amp supply current.
- Power supply input options:
 - a) One (1) common power input for ACM8/ACM8CB and lock power (factory installed).
 - b) Two (2) isolated power inputs - One (1) to power the ACM8/ACM8CB and one (1) for lock accessory power, (external power supply is required). (Current is determined by the power supply connected, not to exceed a maximum of 10 amp total).
- Eight (8) Access Control System trigger inputs.
Input options:
 - a) Eight (8) normally open (NO) inputs.
 - b) Eight (8) open collector inputs.
 - c) Any combination of the above.
- Eight (8) independently controlled outputs.
Output options:
 - a) Eight (8) Fail-Safe and/or Fail-Secure power outputs.
 - b) Eight (8) form "C" 5 amp rated relay outputs (AL1024ULACM only).
 - c) Any combination of the above.
- Eight (8) auxiliary power outputs (unswitched)
- Output ratings:
 - Fuses are rated @ 3.5 amp (AL1024ULACM).
 - PTCs are rated @ 2.5 amp (AL1024ULACMCB).
- Input 115VAC 60Hz rated @ 4.4 amp.
- ACM8 board main fuse is rated at 10 amp
- Filtered and electronically regulated outputs (built-in power supply).
- Short circuit and thermal overload protection.
- Red LEDs indicate outputs are triggered (relays energized)
- Fire Alarm disconnect (latching or non-latching) is individually selectable for any or all of the eight (8) outputs.
Fire Alarm disconnect input options:
 - a) Normally open (NO) or normally closed (NC) dry contact input.
 - b) Polarity reversal input from FACP signaling circuit.
- Alarm output relay indicates that FACP input is triggered (form "C" contact rated @ 1 amp 28VDC not evaluated by UL).
- Green LED indicates when FACP disconnect is triggered.
- Built-in charger for sealed lead acid or gel type batteries.
- AL1024ULXB (Power Supply Board) maximum charge current 3.6 amp.
- Automatic switch over to stand-by battery when AC fails.
- Zero voltage drop when unit switches over to battery backup (AC failure condition).
- AC fail supervision (form "C" contact)
- Battery fail and battery presence supervision (form "C" contact).
- AC input and DC output LED indicators.
- Enclosure accommodates up to two (2) 12AH batteries.

Agency Approvals



UL Listed for Access Control Systems Units
(UL 294).

MEA
Approved

MEA - NYC Department of
Buildings Approved.



CUL Listed - CSA Standard C22.2
No. 205-M1983 Signal Equipment.



CSFM - California State Fire
Marshal Approved.

Enclosure Dimensions

15.5"H x 12"W x 4.5"D

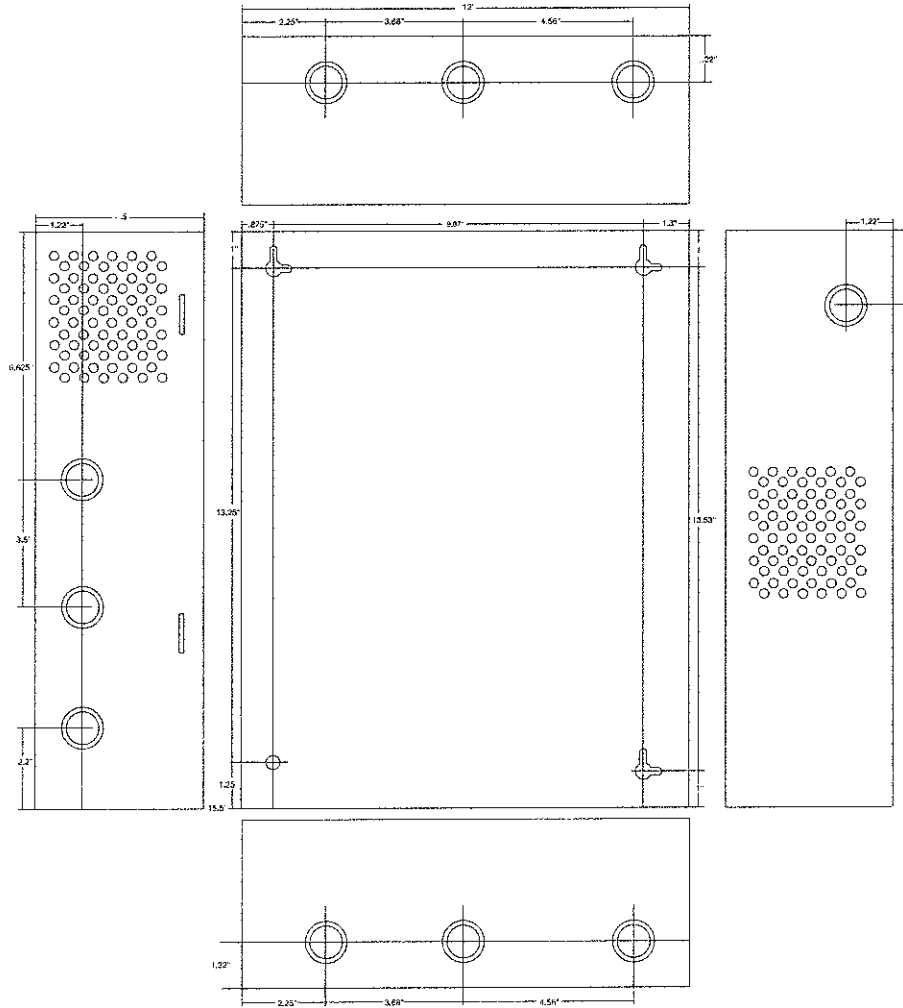



Security Management System

Model SEVMS

Schlage Enterprise Video Management System

Overview

The Schlage Enterprise Video Management System (SEVMS) are state-of-the-art video storage servers available in 4 or 16 camera inputs. Fully integrates with the Schlage Security Management System software packages and captures associated transactions and events. The SEVMS is ready to be put onto any network and can be remotely viewed from any network workstation with the appropriate password protected access level. The SEVMS will accept IP addressable and analog/digital cameras. Each camera can be individually customized with a number of settings such as resolution, frames per second and video motion detection. The user-friendly interface with all PTZ controls on one screen is easily navigated. The SEVMS provides searchable indexed storage for instant access to stored video on a variety of criteria: day, time, camera, alarm etc. The SEVMS storage capability can be sized to fit any application (see ordering information).

FEATURES & BENEFITS

- Built-in network card that supports 10/100 BaseT
- Scheduling 24/7 and Holiday profiles
- JPEG, AVI, and encrypted VFR recording for high quality playback
- High resolution Video Motion Detection with masking capabilities
- Alarms on Video Motion Detection
- Search on Video Motion Detection

(continued)



ORDERING INFORMATION

Monitor, Keyboard and Mouse sold separately (refer to accessories)

SEVMS-4/120 – 120 pps and one 500GB SATA hard drive for video storage, 2U rack mount case

SEVMS-16/480 – 480 pps and two 500GB SATA hard drives for video storage, 4U rack mount case

OPTIONS:

SEVMSEXP-500 – Includes two 500GB SATA hard drives added to the base SEVMS-16/480 unit for additional video storage capacity. The unit will be shipped in a RAID-5 configuration.

SEVMS-UPGRADE – Replaces both default 500GB hard drives in the SEVMS-16/480 with two 750GB SATA hard drives.

SEVMSEXP-750 - Includes two 750GB SATA hard drives added to the upgraded base SEVMS-16/480 unit for additional video storage capacity. The unit will be shipped in a RAID-5 configuration.

SEVMSAUDIO – Audio card provides individual audio to each video channel

SEVMSMIC – Microphone

SEVMSIO – I/O card provides input/output capability to the video channels

FEATURES & BENEFITS *(continued)*

- Maintenance clients can monitor SEVMS units across network
- Uninterrupted recording during playback and image archiving
- Remote viewing with password protection
- Video clips can be easily distributed by authorized personnel via e-mail
- Customizable pre and post recording upon an event
- FIFO capable (first in, first out)
- Proprietary viewer software for viewing encrypted files
- RAID array configurations
- Hot Swappable units available (for SEVMS-16)
- Multiplex video analog output
- 100% date/time synchronization
- Advanced search, playback and save capabilities
- View 4 cameras simultaneously during playback
- Scalable configurations
- Multiple Video Remote (up to 24 cameras can be displayed)
- Advanced security permissions
- Full PTZ functionality (presets, patrols, etc.)
- Virtual camera grouping across servers
- Web Browser with live view & playback capabilities
- Sequencing capabilities
- Video Launcher – access across video clips from a single location
- Storage Calculator – Estimator
- Intelligent analytic video rules engine (optional)
- Database Back up and Recovery
- Independent Camera Audio - Audio per camera channel (Version 8.0 only)
- Independent alarm per channel
- Tracking VMD
- User-friendly video security applications
- Can create web environment
- Hot swappable with standard drive array

ACCESSORIES:

- SCMKM – 17" Flat Screen Monitor, Standard Keyboard, and Mouse
- SMKMBK – Rack mounted Monitor, Keyboard and Mouse
- SMKMKVMBK – Rack Mounted Monitor, Keyboard and Mouse with an 8 Port KVM Switch
- SEVMSCBL – 12 foot cable to connect SEVMS to rack mounted Monitor, Keyboard, and Mouse (SMKMBK + SMKMKVMBK)
- SEVMSCNV485 – Data converter for 485 PTZ control through the SEVMS
- SEVMSCNV422 – Data converter for 422 PTZ control through the SEVMS

SPECIFICATIONS:

- Input Voltage: 120VAC or 240VAC
- Operating temperature: 50F to 75F
- CPU: P-4 3.4GHz 800MHz
- RAM: 1024MB PC3200
- Floppy: 1.44MB
- DVD-R/W & CD-R/W: Internal
- DVD-R/W Software: Included
- Video card: 128MB PCI-E VGA, DV1-1 & TV-Out
- Video connectors: BNC Video Inputs
- Network card: Integrated Ethernet
- Operating system: Windows XP Professional SP2
- O/S hard drive: 80 GB SATA
- SEVMS-4 Dimensions: 3-1/2"H x 19"W x 19"D
- SEVMS-16 Dimensions: 7"H x 19"W x 19"D



Schlage

Electronic Security
575 Birch Street
Forestville, CT 06010 USA
Tel 860-584-9158/866-322-1237
Fax 860-584-2136/866-322-1233
Tel 800-950-4573 (Toll Free Canada)
www.schlage.com

Bullet Camera

Day/Night, 550 TV Lines, 36 IR LEDs, Weatherproof Bullet Camera

CB-HD21N-L

NTSC

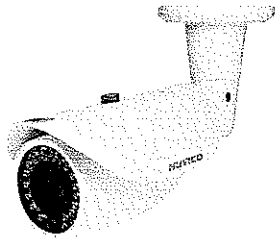

KEY FEATURES

- 1/3" CCD Sensor
- 550 TV Lines (Color) 600 TV Lines (B/W)
- 2.8-10mm DC Auto Iris Lens
- Day/Night Functionality with ICR
- 0.1 Lux (Color) 0.00 Lux (B/W IR LEDs On)
- 36 IR LEDs
- Built-in IR LEDs On/Off Switch
- Dip Switch Menu
- Service Monitor Output
- 12VDC/24VAC Dual Voltage

CONSTRUCTION

- 3-Axis Aluminum Bracket (Wire feed-through)
- Weatherproof Aluminum Housing

TECHNICAL SPECIFICATIONS

Technical Specifications	CB-HD21N-L
Video Format	NTSC/PAL
Image Sensor	1/3" CCD
Horizontal Resolution	550 TV Lines (Color) 600 TV Lines (B/W)
Day/Night Functionality	Yes w/ ICR
Lens Type (DC Auto Iris)	Vari-focal 2.8mm-10mm
Angle of View	132 1°(W) ~ 36°(T)
IR LEDs	36
IR LEDs Distance	Up to 100ft
LEDs Illumination Angle	80°
Sync System	Internal
Effective Pixels (HxV)	768(H) x 494(V)
Scanning System	525 Lines 2:1 Interlaced
Electronic Shutter	1/60 sec
Main Video Output	1.0 Vp-p Composite 75 ohm
Service Monitor Output	1.0 Vp-p Composite, 75 ohm
Minimum Illumination	0.1 Lux (Color), 0.00 Lux (B/W IR LEDs On)
S/N Ratio	More than 48dB (AGC Off)
Camera Control & Setup	Dip Switch Menu
General Information	CB-HD21N-L
Operating Temperature	23°F ~ 113°F
Operating Humidity	Within 90% RH
Power Consumption	1 Amp (LEDs On) 500 mA (Camera Only)
Input Voltage	12VDC/24VAC Dual Voltage

*specifications are subject to change without any prior notice

PART NAMES AND LOCATIONS

- ① Bolt
- ② Sun Shield
- ③ Front Case
- ④ Back Case
- ⑤ Service Monitor Output Cap
- ⑥ Bracket
- ⑦ Power Input (24VAC/12VDC)
Video Output Connector

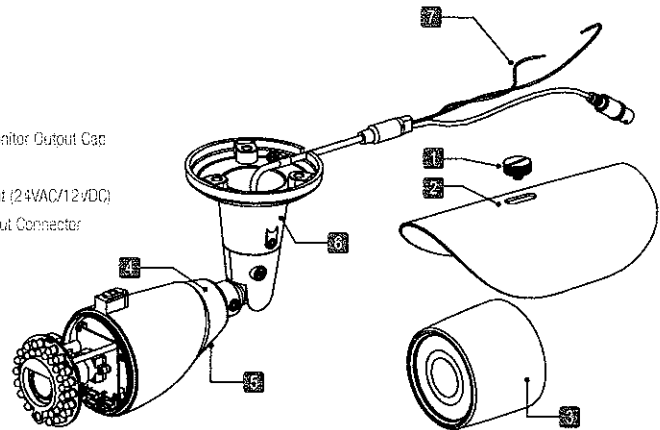

DIMENSIONS

Unit: inch (mm)

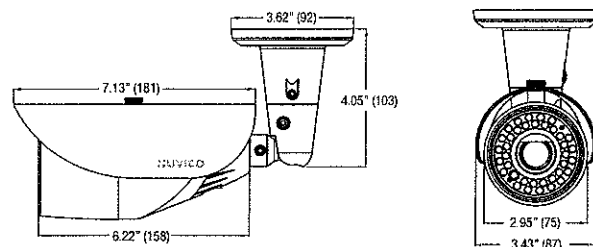

BID BOND

KNOW ALL MEN BY THESE PRESENTS, That we, the undersigned, Mountain State Building Automation, LLC
of Sissonville, WV, as Principal, and United States Surety Company
of Timonium, MD, a corporation organized and existing under the laws of the State of MD
with its principal office in the City of Timonium, as Surety, are held and firmly bound unto the State
of West Virginia, as Obligee, in the penal sum of Five Percent of Amount Bid (\$ 5%) for the payment of which,
well and truly to be made, we jointly and severally bind ourselves, our heirs, administrators, executors, successors and assigns

The Condition of the above obligation is such that whereas the Principal has submitted to the Purchasing Section of the
Department of Administration a certain bid or proposal, attached hereto and made a part hereof, to enter into a contract in writing for
WSH10002 - Access Control Security System - William R Sharpe Jr Hospital - According to Plans & Specifications

NOW THEREFORE,

(a) If said bid shall be rejected, or
(b) If said bid shall be accepted and the Principal shall enter into a contract in accordance with the bid or proposal attached
hereto and shall furnish any other bonds and insurance required by the bid or proposal, and shall in all other respects perform the
agreement created by the acceptance of said bid, then this obligation shall be null and void, otherwise this obligation shall remain in full
force and effect. It is expressly understood and agreed that the liability of the Surety for any and all claims hereunder shall, in no event,
exceed the penal amount of this obligation as herein stated

The Surety, for the value received, hereby stipulates and agrees that the obligations of said Surety and its bond shall be in no
way impaired or affected by any extension of the time within which the Obligee may accept such bid, and said Surety does hereby
waive notice of any such extension

IN WITNESS WHEREOF, Principal and Surety have hereunto set their hands and seals, and such of them as are corporations
have caused their corporate seals to be affixed hereunto and these presents to be signed by their proper officers, this
20th day of August, 2009

Principal Corporate Seal

Mountain State Building Automation, LLC

(Name of Principal)

By: Paul R. Burdette

(Must be President or
Vice President)

Paul R. Burdette Managing Member

(Title)

Surety Corporate Seal

United States Surety Company

(Name of Surety)

By: Patricia A. Moye

Patricia A. Moye, WV Resident Agent Attorney-in-Fact

POWER OF ATTORNEY

AMERICAN CONTRACTORS INDEMNITY COMPANY UNITED STATES SURETY COMPANY U S SPECIALTY INSURANCE COMPANY

KNOW ALL MEN BY THESE PRESENTS: That American Contractors Indemnity Company, a California corporation, United States Surety Company, a Maryland corporation, and U S Specialty Insurance Company, a Texas corporation (collectively, the "Companies"), do by these presents make, constitute and appoint: Gregory T. Gordon, Larry D. Kerr, Allan L. McVey, Patricia A. Moye, Kimberly J. Wilkinson

its true and lawful Attorney(s)-in-fact, each in their separate capacity if more than one is named above, with full power and authority hereby conferred in its name, place and stead, to execute, acknowledge and deliver any and all bonds, recognizances, undertakings or other instruments or contracts of suretyship to include riders, amendments, and consents of surety This Power of Attorney is granted under and by authority of the following resolutions adopted by the Boards of Directors of the Companies:

Be it Resolved, that the President, any Vice-President, any Assistant Vice-President, any Secretary or any Assistant Secretary shall be and is hereby vested with full power and authority to appoint any one or more suitable persons as Attorney(s)-in-Fact to represent and act for and on behalf of the Company subject to the following provisions:

Attorney-in-Fact may be given full power and authority for and in the name of and on behalf of the Company to execute, acknowledge and deliver, any and all bonds, recognizances, contracts, agreements or indemnity and other conditional or obligatory undertakings and any and all notices and documents canceling or terminating the Company's liability thereunder, and any such instruments so executed by any such Attorney-in-Fact shall be binding upon the Company as if signed by the President and sealed and effected by the Corporate Secretary.

Be it Resolved, that the signature of any authorized officer and seal of the Company heretofore or hereafter affixed to any power of attorney or any certificate relating thereto by facsimile, and any power of attorney or certificate bearing facsimile signature or facsimile seal shall be valid and binding upon the Company with respect to any bond or undertaking to which it is attached

IN WITNESS WHEREOF, the Companies have caused this instrument to be signed and their corporate seals to be hereto affixed, this 25th day of July, 2008

AMERICAN CONTRACTORS INDEMNITY COMPANY UNITED STATES SURETY COMPANY U S SPECIALTY INSURANCE COMPANY Corporate Seals



By: [Signature] Peter W Carman, Vice President

State of Maryland County of Baltimore SS:

On this 4th day of December 2008, before me, Jean Grzymala, a notary public, personally appeared Peter W Carman, Vice President of American Contractors Indemnity Company, United States Surety Company and U S Specialty Insurance Company who proved to me on the basis of satisfactory evidence to be the person whose name is subscribed to the within instrument and acknowledged to me that he executed the same in his authorized capacity, and that by his signature on the instrument the person(s), or the entity upon behalf of which the person(s) acted, executed the instrument.

I certify under PENALTY OF PERJURY under the laws of the State of Maryland that the foregoing paragraph is true and correct WITNESS my hand and official seal.

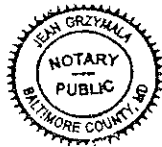

Signature: [Signature] My commission expires the 15th day of December, 2012

I, Carol I. Nevin, Assistant Secretary of American Contractors Indemnity Company, United States Surety Company and U S Specialty Insurance Company, do hereby certify that the above and foregoing is a true and correct copy of a Power of Attorney, executed by said Companies, which is still in full force and effect; furthermore, the resolutions of the Boards of Directors, set out in the Power of Attorney are in full force and effect

In Witness Whereof, I have hereunto set my hand and affixed the seals of said Companies at Baltimore, Maryland this 20th day of August 2009

[Signature] Carol T. Nevin, Assistant Secretary

