



State of West Virginia
 Department of Administration
 Purchasing Division
 2019 Washington Street East
 Post Office Box 50130
 Charleston, WV 25305-0130

Request for Quotation

RFO NUMBER
 WSH10002

PAGE
 1

ADDRESS CORRESPONDENCE TO ATTENTION OF
 ROBERTA WAGNER
 304-558-0067

RFQ COPY

TYPE NAME/ADDRESS HERE

VENDOR

Advanced Alarm Technologies
 PO Box 4368
 Parkersburg, WV 26104

SHIP TO

HEALTH AND HUMAN RESOURCES
 WILLIAM R SHARPE JR. HOSPITAL
 CENTRAL RECEIVING
 936 SHARPE HOSPITAL ROAD
 WESTON, WV 26452
 304-269-1210

DATE PRINTED	TERMS OF SALE	SHIP VIA	F.O.B.	FREIGHT TERMS
07/01/2009				

BID OPENING DATE: 08/04/2009 BID OPENING TIME 01:30PM

LINE	QUANTITY	UOP	CAT NO	ITEM NUMBER	UNIT PRICE	AMOUNT
0001	1	JB	990-22		80,495.00	80,495.00
<p>***** MANDATORY PRE-BID MEETING IS SCHEDULED FOR JULY 15, 2009 AT 1:00 PM AT WILLIAM R. SHARPE, JR HOSPITAL, 936 SHARPE HOSPITAL ROAD, WESTON, WV 26452 NO ONE PERSON MAY REPRESENT MORE THAN ONE VENDOR. *****</p> <p>ACCESS CONTROL SECURITY SYSTEM</p> <p>WILLIAM R SHARPE JR HOSPITAL IS SEEKING BIDS FOR THE PURCHASE AND INSTALLATION OF AN ACCESS CONTROL SECURITY SYSTEM DESIGNED TO INCLUDE READER-IN/READER-OUT CAPABILITIES AT SEVENTEEN (17) EXTERIOR DOORS AT THE FACILITY. THE SYSTEM MUST MEET FIRE MARSHALL AND OTHER HOSPITAL REGULATIONS AND REQUIREMENTS.</p> <p>(SEE ATTACHED SPECIFICATIONS.)</p> <p>VENDOR IS IDENTIFY THE PRODUCT AND PROVIDE PRODUCT BROCHURES AS TO ABILITY TO MEET THE BID SPECIFICATIONS.</p> <p>A MANDATORY VENDOR PREBID CONFERENCE IS SCHEDULED FOR JULY 15, 2009 AT 1:00 PM IN THE BUSINESS OFFICE OF WILLIAM R SHARPE JR HOSPITAL, 936 SHARPE HOSPITAL ROAD, WESTON, WV 26452.</p> <p>INQUIRIES:</p>						

RECEIVED

2009 AUG 18 AM 10:13

WV PURCHASING DIVISION

SEE REVERSE SIDE FOR TERMS AND CONDITIONS

SIGNATURE <i>Shirley Hester</i>	TELEPHONE (304) 422-4387	DATE 8/14/09
TITLE President	FBN 20-2085989	ADDRESS CHANGES TO BE NOTED ABOVE

WHEN RESPONDING TO RFQ, INSERT NAME AND ADDRESS IN SPACE ABOVE LABELED 'VENDOR'

FAX # (304) 422-4387
 Email: advancedalarm@suddenlink.net

GENERAL TERMS & CONDITIONS
REQUEST FOR QUOTATION (RFQ) AND REQUEST FOR PROPOSAL (RFP)

1. Awards will be made in the best interest of the State of West Virginia.
2. The State may accept or reject in part, or in whole, any bid
3. All quotations are governed by the *West Virginia Code* and the *Legislative Rules* of the Purchasing Division
4. Prior to any award, the apparent successful vendor must be properly registered with the Purchasing Division and have paid the required \$125 fee
5. All services performed or goods delivered under State Purchase Order/Contracts are to be continued for the term of the Purchase Order/Contracts, contingent upon funds being appropriated by the Legislature or otherwise being made available. In the event funds are not appropriated or otherwise available for these services or goods, this Purchase Order/Contract becomes void and of no effect after June 30
6. Payment may only be made after the delivery and acceptance of goods or services
7. Interest may be paid for late payment in accordance with the *West Virginia Code*
8. Vendor preference will be granted upon written request in accordance with the *West Virginia Code*
9. The State of West Virginia is exempt from federal and state taxes and will not pay or reimburse such taxes
10. The Director of Purchasing may cancel any Purchase Order/Contract upon 30 days written notice to the seller
11. The laws of the State of West Virginia and the *Legislative Rules* of the Purchasing Division shall govern all rights and duties under the Contract, including without limitation the validity of this Purchase Order/Contract
12. Any reference to automatic renewal is hereby deleted. The Contract may be renewed only upon mutual written agreement of the parties
13. **BANKRUPTCY:** In the event the vendor/contractor files for bankruptcy protection, the State may deem this contract null and void, and terminate such contract without further order
14. **HIPAA BUSINESS ASSOCIATE ADDENDUM:** The West Virginia State Government HIPAA Business Associate Addendum (BAA), approved by the Attorney General, and available online at the Purchasing Division's web site (<http://www.state.wv.us/admin/purchase/vrc/hipaa.htm>) is hereby made part of the agreement. Provided that, the Agency meets the definition of a Cover Entity (45 CFR §160 103) and will be disclosing Protected Health Information (45 CFR §160 103) to the vendor
15. **WEST VIRGINIA ALCOHOL & DRUG-FREE WORKPLACE ACT:** If this Contract constitutes a public improvement construction contract as set forth in Article 1D, Chapter 21 of the West Virginia Code ("The West Virginia Alcohol and Drug-Free Workplace Act"), then the following language shall hereby become part of this Contract: "The contractor and its subcontractors shall implement and maintain a written drug-free workplace policy in compliance with the West Virginia Alcohol and Drug-Free Workplace Act, as set forth in Article 1D, Chapter 21 of the West Virginia Code. The contractor and its subcontractors shall provide a sworn statement in writing, under the penalties of perjury, that they maintain a valid drug-free work place policy in compliance with the West Virginia and Drug-Free Workplace Act. It is understood and agreed that this Contract shall be cancelled by the awarding authority if the Contractor: 1) Fails to implement its drug-free workplace policy; 2) Fails to provide information regarding implementation of the contractor's drug-free workplace policy at the request of the public authority; or 3) Provides to the public authority false information regarding the contractor's drug-free workplace policy."

INSTRUCTIONS TO BIDDERS

1. Use the quotation forms provided by the Purchasing Division
2. **SPECIFICATIONS:** Items offered must be in compliance with the specifications. Any deviation from the specifications must be clearly indicated by the bidder. Alternates offered by the bidder as **EQUAL** to the specifications must be clearly defined. A bidder offering an alternate should attach complete specifications and literature to the bid. The Purchasing Division may waive minor deviations to specifications
3. Complete all sections of the quotation form
4. Unit prices shall prevail in case of discrepancy
5. All quotations are considered F O B destination unless alternate shipping terms are clearly identified in the quotation
6. **BID SUBMISSION:** All quotations must be delivered by the bidder to the office listed below prior to the date and time of the bid opening. Failure of the bidder to deliver the quotations on time will result in bid disqualifications: Department of Administration, Purchasing Division, 2019 Washington Street East, P O Box 50130, Charleston, WV 25305-0130



State of West Virginia
 Department of Administration
 Purchasing Division
 2019 Washington Street East
 Post Office Box 50130
 Charleston, WV 25305-0130

Request for Quotation

RFQ NUMBER
 WSH10002

PAGE
 2

ADDRESS CORRESPONDENCE TO ATTENTION OF:
 ROBERTA WAGNER
 304-558-0067

RFQ COPY

TYPE NAME/ADDRESS HERE

SHIP TO

HEALTH AND HUMAN RESOURCES
 WILLIAM R. SHARPE JR. HOSPITAL
 CENTRAL RECEIVING
 936 SHARPE HOSPITAL ROAD
 WESTON, WV
 26452 304-269-1210

DATE PRINTED	TERMS OF SALE	SHIP VIA	F.O.B.	FREIGHT TERMS
07/01/2009				

BID OPENING DATE: 08/04/2009 BID OPENING TIME 01:30PM

LINE	QUANTITY	UOP	CAT NO	ITEM NUMBER	UNIT PRICE	AMOUNT
<p>WRITTEN QUESTIONS SHALL BE ACCEPTED THROUGH CLOSE OF BUSINESS ON 7/16/2009. QUESTIONS MAY BE SENT VIA USPS, FAX, COURIER OR E-MAIL. IN ORDER TO ASSURE NO VENDOR RECEIVES AN UNFAIR ADVANTAGE, NO SUBSTANTIVE QUESTIONS WILL BE ANSWERED ORALLY. IF POSSIBLE, E-MAIL QUESTIONS ARE PREFERRED. ADDRESS INQUIRIES TO:</p> <p>ROBERTA WAGNER DEPARTMENT OF ADMINISTRATION PURCHASING DIVISION 2019 WASHINGTON STREET, EAST CHARLESTON, WV 25311</p> <p>FAX: 304-558-4115 E-MAIL: ROBERTA.A.WAGNER@WV.GOV</p> <p>NOTICE TO PROCEED: THIS CONTRACT IS TO BE PERFORMED WITHIN 120 CALENDAR DAYS AFTER THE NOTICE TO PROCEED IS RECEIVED.</p> <p>CANCELLATION: THE DIRECTOR OF PURCHASING RESERVES THE RIGHT TO CANCEL THIS CONTRACT IMMEDIATELY UPON WRITTEN NOTICE TO THE VENDOR IF THE MATERIALS OR WORKMANSHIP SUPPLIED ARE OF AN INFERIOR QUALITY OR DO NOT CONFORM WITH THE SPECIFICATIONS OF THE BID AND CONTRACT HERE IN.</p> <p>WAGE RATES: THE CONTRACTOR OR SUBCONTRACTOR SHALL PAY THE HIGHER OF THE U.S. DEPARTMENT OF LABOR MINIMUM WAG</p>						

SEE REVERSE SIDE FOR TERMS AND CONDITIONS

SIGNATURE	TELEPHONE	DATE
TITLE	FEIN	ADDRESS CHANGES TO BE NOTED ABOVE

WHEN RESPONDING TO RFQ, INSERT NAME AND ADDRESS IN SPACE ABOVE LABELED 'VENDOR'



State of West Virginia
 Department of Administration
 Purchasing Division
 2019 Washington Street East
 Post Office Box 50130
 Charleston, WV 25305-0130

Request for Quotation

RFQ NUMBER
 WSH10002

PAGE
 3

ADDRESS CORRESPONDENCE TO ATTENTION OF
 ROBERTA WAGNER
 304-558-0067

RFQ COPY
 TYPE NAME/ADDRESS HERE

VENDOR

SHIP TO

HEALTH AND HUMAN RESOURCES
 WILLIAM R. SHARPE JR. HOSPITAL
 CENTRAL RECEIVING
 936 SHARPE HOSPITAL ROAD
 WESTON, WV
 26452 304-269-1210

DATE PRINTED	TERMS OF SALE	SHIP VIA	F.O.B.	FREIGHT TERMS
07/01/2009				

BID OPENING DATE: 08/04/2009 BID OPENING TIME 01:30PM

LINE	QUANTITY	UOP	CAT NO.	ITEM NUMBER	UNIT PRICE	AMOUNT
<p>RATES AS ESTABLISHED FOR LEWIS COUNTY, PURSUANT TO WEST VIRGINIA CODE 21-5A, ET, SEQ. (PREVAILING WAGE RATES APPLY TO THIS PROJECT)</p> <p>WORKERS' COMPENSATION: VENDOR IS REQUIRED TO PROVIDE A CERTIFICATE FROM WORKERS' COMPENSATION IF SUCCESSFUL.</p> <p>ALL OF THE ITEMS CHECKED BELOW WILL BE A REQUIREMENT OF THIS CONTRACT:</p> <p>(XX) INSURANCE: SUCCESSFUL VENDOR SHALL FURNISH PROOF OF COMMERCIAL GENERAL LIABILITY INSURANCE PRIOR TO ISSUANCE OF CONTRACT. UNLESS OTHERWISE SPECIFIED IN THE BID DOCUMENTS, THE MINIMUM AMOUNT OF INSURANCE COVERAGE REQUIRED IS \$250,000.</p> <p>CONTRACTORS LICENSE</p> <p>BIDDER TO COMPLETE:</p> <p>CONTRACTORS NAME: <i>Advanced Alarm Technologies</i></p> <p>CONTRACTORS LICENSE NO.: <i>WV 025246</i></p> <p>THE SUCCESSFUL BIDDER WILL BE REQUIRED TO FURNISH A COPY OF THEIR CONTRACTORS LICENSE PRIOR TO ISSUANCE OF A PURCHASE ORDER/CONTRACT</p> <p>APPLICABLE LAW</p> <p>THE WEST VIRGINIA STATE CODE, PURCHASING DIVISION RULES AND REGULATIONS, AND THE INFORMATION PROVIDED IN THE "REQUEST FOR QUOTATION" ISSUED BY THE PURCHASING</p>						

SEE REVERSE SIDE FOR TERMS AND CONDITIONS

SIGNATURE	TELEPHONE	DATE
TITLE	FERN	ADDRESS CHANGES TO BE NOTED ABOVE

WHEN RESPONDING TO RFQ, INSERT NAME AND ADDRESS IN SPACE ABOVE LABELED 'VENDOR'



State of West Virginia
 Department of Administration
 Purchasing Division
 2019 Washington Street East
 Post Office Box 50130
 Charleston, WV 25305-0130

**Request for
 Quotation**

RFQ NUMBER
 WSH10002

PAGE
 4

ADDRESS CORRESPONDENCE TO ATTENTION OF
 ROBERTA WAGNER
 304-558-0067

V
E
N
D
O
R

RFQ COPY
 TYPE NAME/ADDRESS HERE

S
H
I
P
T
O

HEALTH AND HUMAN RESOURCES
 WILLIAM R. SHARPE JR HOSPITAL
 CENTRAL RECEIVING
 936 SHARPE HOSPITAL ROAD
 WESTON, WV
 26452 304-269-1210

DATE PRINTED 07/01/2009	TERMS OF SALE	SHIP VIA	FOB	FREIGHT TERMS
----------------------------	---------------	----------	-----	---------------

BID OPENING DATE: 08/04/2009 BID OPENING TIME 01:30PM

LINE	QUANTITY	UOP	CAT NO.	ITEM NUMBER	UNIT PRICE	AMOUNT
<p>DIVISION IS THE SOLE AUTHORITY GOVERNING THIS PROCUREMENT.</p> <p>ANY INFORMATION PROVIDED IN SPECIFICATION MANUALS, OR ANY OTHER SOURCE, VERBAL OR WRITTEN, WHICH CONTRADICTS OR ALTERS THE INFORMATION PROVIDED FROM THE SOURCES AS DESCRIBED IN THE ABOVE PARAGRAPH IS VOID AND OF NO EFFECT.</p> <p>BANKRUPTCY: IN THE EVENT THE VENDOR/CONTRACTOR FILES FOR BANKRUPTCY PROTECTION, THE STATE MAY DEEM THE CONTRACT NULL AND VOID AND TERMINATE SUCH CONTRACT WITHOUT FURTHER ORDER.</p> <p>REV. 5/2009</p> <p style="text-align: center;">NOTICE</p> <p>A SIGNED BID MUST BE SUBMITTED TO:</p> <p style="text-align: center;">DEPARTMENT OF ADMINISTRATION PURCHASING DIVISION BUILDING 15 2019 WASHINGTON STREET, EAST CHARLESTON, WV 25305-0130</p> <p>PLEASE NOTE: A CONVENIENCE COPY WOULD BE APPRECIATED.</p> <p>THE BID SHOULD CONTAIN THIS INFORMATION ON THE FACE OF THE ENVELOPE OR THE BID MAY NOT BE CONSIDERED:</p> <p>SEALED BID</p> <p>BUYER:-----RW/FILE 22-----</p> <p>REQ. NO.:-----WSH10002-----</p>						

SEE REVERSE SIDE FOR TERMS AND CONDITIONS

SIGNATURE	TELEPHONE	DATE
TITLE	FEIN	ADDRESS CHANGES TO BE NOTED ABOVE

WHEN RESPONDING TO RFQ, INSERT NAME AND ADDRESS IN SPACE ABOVE LABELED 'VENDOR'

SPECIFICATIONS ACCESS CONTROL SECURITY SYSTEM

West Virginia Department of Health and Human Resources
Bureau for Behavioral Health and Health Facilities
William R. Sharpe, Jr. Hospital
936 Sharpe Hospital Road
Weston, West Virginia 26452

SPECIFICATIONS

William R. Sharpe, Jr. Hospital is seeking bids for the purchase and installation of an access control system designed to include reader in/reader out capabilities at seventeen (17) exterior doors at the facility.

GENERAL CONDITIONS

It is the intent of the Hospital to purchase only those services as listed.

SCOPE OF WORK

Install proximity card readers, electronic door hardware & ancillary equipment for seventeen (17) exterior doors at William R. Sharpe, Jr. Hospital.

System requirements:

- 1 The hardware equipment must be integrated with vendor provided management software, which will be used by the security office, safety office, maintenance department and the switchboard
- 2 The card reader system must be capable of connecting to the existing Edwards EST III fire alarm system and must comply with all Fire Marshall regulations.
- 3 Proximity card readers must be installed at each of the seventeen (17) exterior doors
- 4 A magnetic lock must be installed at each of the seventeen (17) exterior doors
- 5 All computer hardware and software equipment required to run the system
- 6 A system to generate and assign 650 access cards to the staff of the hospital
- 7 The system must be capable of expansion and upgrading to include up to a maximum of seventeen (17) video cameras and a maximum of ten (10) additional doors
- 8 Must have a battery back-up system that can power the product temporarily for fifteen (15) minutes during a power outage.
- 9 Two year full warranty on all software, hardware, parts and labor.
- 10 The price must include complete installation and labor for the project at minimum prevailing wages for Lewis County if applicable.

The successful vendor must be registered with the State of West Virginia and will be required to provide a valid current contractor's license and proof of liability insurance.

A Notice to Proceed Letter will advise the successful vendor when the project is to start. The project must be completed within 120 days of the notice to proceed.

STATE OF WEST VIRGINIA
Purchasing Division

PURCHASING AFFIDAVIT

VENDOR OWING A DEBT TO THE STATE:

West Virginia Code §5A-3-10a provides that: No contract or renewal of any contract may be awarded by the state or any of its political subdivisions to any vendor or prospective vendor when the vendor or prospective vendor or a related party to the vendor or prospective vendor is a debtor and the debt owed is an amount greater than one thousand dollars in the aggregate.

PUBLIC IMPROVEMENT CONTRACTS & DRUG-FREE WORKPLACE ACT:

If this is a solicitation for a public improvement construction contract, the vendor, by its signature below, affirms that it has a written plan for a drug-free workplace policy in compliance with Article 1D, Chapter 21 of the *West Virginia Code*. The vendor must make said affirmation with its bid submission. Further, public improvement construction contract may not be awarded to a vendor who does not have a written plan for a drug-free workplace policy in compliance with Article 1D, Chapter 21 of the *West Virginia Code* and who has not submitted that plan to the appropriate contracting authority in timely fashion. For a vendor who is a subcontractor, compliance with Section 5, Article 1D, Chapter 21 of the *West Virginia Code* may take place before their work on the public improvement is begun.

ANTITRUST:

In submitting a bid to any agency for the state of West Virginia, the bidder offers and agrees that if the bid is accepted the bidder will convey, sell, assign or transfer to the state of West Virginia all rights, title and interest in and to all causes of action it may now or hereafter acquire under the antitrust laws of the United States and the state of West Virginia for price fixing and/or unreasonable restraints of trade relating to the particular commodities or services purchased or acquired by the state of West Virginia. Such assignment shall be made and become effective at the time the purchasing agency tenders the initial payment to the bidder.

I certify that this bid is made without prior understanding, agreement, or connection with any corporation, firm, limited liability company, partnership or person or entity submitting a bid for the same materials, supplies, equipment or services and is in all respects fair and without collusion or fraud. I further certify that I am authorized to sign the certification on behalf of the bidder or this bid.

LICENSING:

Vendors must be licensed and in good standing in accordance with any and all state and local laws and requirements by any state or local agency of West Virginia, including, but not limited to, the West Virginia Secretary of State's Office, the West Virginia Tax Department, West Virginia Insurance Commission, or any other state agencies or political subdivision. Furthermore, the vendor must provide all necessary releases to obtain information to enable the Director or spending unit to verify that the vendor is licensed and in good standing with the above entities.

CONFIDENTIALITY:

The vendor agrees that he or she will not disclose to anyone, directly or indirectly, any such personally identifiable information or other confidential information gained from the agency, unless the individual who is the subject of the information consents to the disclosure in writing or the disclosure is made pursuant to the agency's policies, procedures and rules. Vendor further agrees to comply with the Confidentiality Policies and Information Security Accountability Requirements, set forth in <http://www.state.wv.us/admin/purchase/privacy/noticeConfidentiality.pdf>.

Under penalty of law for false swearing (*West Virginia Code* §61-5-3), it is hereby certified that the vendor affirms and acknowledges the information in this affidavit and is in compliance with the requirements as stated.

Vendor's Name: Advanced Alarm Technologies
Authorized Signature: Paul H. Hill Date: 8/14/09

State of West Virginia VENDOR PREFERENCE CERTIFICATE

Certification and application* is hereby made for Preference in accordance with **West Virginia Code, §5A-3-37**. (Does not apply to construction contracts). **West Virginia Code, §5A-3-37**, provides an opportunity for qualifying vendors to request (at the time of bid) preference for their residency status. Such preference is an evaluation method only and will be applied only to the cost bid in accordance with the **West Virginia Code**. This certificate for application is to be used to request such preference. The Purchasing Division will make the determination of the Resident Vendor Preference, if applicable.

1 Application is made for 2.5% resident vendor preference for the reason checked:
 Bidder is an individual resident vendor and has resided continuously in West Virginia for four (4) years immediately preceding the date of this certification; or,
 Bidder is a partnership, association or corporation resident vendor and has maintained its headquarters or principal place of business continuously in West Virginia for four (4) years immediately preceding the date of this certification; or 80% of the ownership interest of Bidder is held by another individual, partnership, association or corporation resident vendor who has maintained its headquarters or principal place of business continuously in West Virginia for four (4) years immediately preceding the date of this certification; or,
 Bidder is a nonresident vendor which has an affiliate or subsidiary which employs a minimum of one hundred state residents and which has maintained its headquarters or principal place of business within West Virginia continuously for the four (4) years immediately preceding the date of this certification; or,

2 Application is made for 2.5% resident vendor preference for the reason checked:
 Bidder is a resident vendor who certifies that, during the life of the contract, on average at least 75% of the employees working on the project being bid are residents of West Virginia who have resided in the state continuously for the two years immediately preceding submission of this bid; or,

3. Application is made for 2.5% resident vendor preference for the reason checked:
 Bidder is a nonresident vendor employing a minimum of one hundred state residents or is a nonresident vendor with an affiliate or subsidiary which maintains its headquarters or principal place of business within West Virginia employing a minimum of one hundred state residents who certifies that, during the life of the contract, on average at least 75% of the employees or Bidder's affiliate's or subsidiary's employees are residents of West Virginia who have resided in the state continuously for the two years immediately preceding submission of this bid; or,

~~**4. Application is made for 5% resident vendor preference for the reason checked:**~~
 Bidder meets either the requirement of both subdivisions (1) and (2) or subdivision (1) and (3) as stated above; or,

5. Application is made for 3.5% resident vendor preference who is a veteran for the reason checked:
 Bidder is an individual resident vendor who is a veteran of the United States armed forces, the reserves or the National Guard and has resided in West Virginia continuously for the four years immediately preceding the date on which the bid is submitted; or,

6. Application is made for 3.5% resident vendor preference who is a veteran for the reason checked:
 Bidder is a resident vendor who is a veteran of the United States armed forces, the reserves or the National Guard, if, for purposes of producing or distributing the commodities or completing the project which is the subject of the vendor's bid and continuously over the entire term of the project, on average at least seventy-five percent of the vendor's employees are residents of West Virginia who have resided in the state continuously for the two immediately preceding years

Bidder understands if the Secretary of Revenue determines that a Bidder receiving preference has failed to continue to meet the requirements for such preference, the Secretary may order the Director of Purchasing to: (a) reject the bid; or (b) assess a penalty against such Bidder in an amount not to exceed 5% of the bid amount and that such penalty will be paid to the contracting agency or deducted from any unpaid balance on the contract or purchase order.

By submission of this certificate, Bidder agrees to disclose any reasonably requested information to the Purchasing Division and authorizes the Department of Revenue to disclose to the Director of Purchasing appropriate information verifying that Bidder has paid the required business taxes, provided that such information does not contain the amounts of taxes paid nor any other information deemed by the Tax Commissioner to be confidential.

Under penalty of law for false swearing (West Virginia Code, §61-5-3), Bidder hereby certifies that this certificate is true and accurate in all respects; and that if a contract is issued to Bidder and if anything contained within this certificate changes during the term of the contract, Bidder will notify the Purchasing Division in writing immediately.

Bidder: Advanced Alarm Technologies Signed: [Signature]
Date: 8/14/09 Title: President

*Check any combination of preference consideration(s) indicated above which you are entitled to receive

ATTACHMENT
PO # WSH10002

This agreement constitutes the entire agreement between the parties, and there are no other terms and conditions applicable to the licenses granted hereunder

Agreed

Paul Hibel 8/14/09
Signature Date

President
Title

Advanced Alarm Technologies
Company Name

Signature Date

Title

Agency/Division

WV-96
Rev. 10/07

AGREEMENT ADDENDUM

In the event of conflict between this addendum and the agreement, this addendum shall control:

1. **DISPUTES** - Any references in the agreement to arbitration or to the jurisdiction of any court are hereby deleted. Disputes arising out of the agreement shall be presented to the West Virginia Court of Claims
2. **HOLD HARMLESS** - Any clause requiring the Agency to indemnify or hold harmless any party is hereby deleted in its entirety
3. **GOVERNING LAW** - The agreement shall be governed by the laws of the State of West Virginia. This provision replaces any references to any other State's governing law.
4. **TAXES** - Provisions in the agreement requiring the Agency to pay taxes are deleted. As a State entity, the Agency is exempt from Federal, State, and local taxes and will not pay taxes for any Vendor including individuals, nor will the Agency file any tax returns or reports on behalf of Vendor or any other party
5. **PAYMENT** - Any references to prepayment are deleted. Payment will be in arrears
6. **INTEREST** - Should the agreement include a provision for interest on late payments, the Agency agrees to pay the maximum legal rate under West Virginia law. All other references to interest or late charges are deleted
7. **RECOUPMENT** - Any language in the agreement waiving the Agency's right to set-off, counterclaim, recoupment, or other defense is hereby deleted.
8. **FISCAL YEAR FUNDING** - Service performed under the agreement may be continued in succeeding fiscal years for the term of the agreement, contingent upon funds being appropriated by the Legislature or otherwise being available for this service. In the event funds are not appropriated or otherwise available for this service, the agreement shall terminate without penalty on June 30. After that date, the agreement becomes of no effect and is null and void. However, the Agency agrees to use its best efforts to have the amounts contemplated under the agreement included in its budget. Non-appropriation or non-funding shall not be considered an event of default.
9. **STATUTE OF LIMITATION** - Any clauses limiting the time in which the Agency may bring suit against the Vendor, lessor, individual, or any other party are deleted.
10. **SIMILAR SERVICES** - Any provisions limiting the Agency's right to obtain similar services or equipment in the event of default or non-funding during the term of the agreement are hereby deleted
11. **ATTORNEY FEES** - The Agency recognizes an obligation to pay attorney's fees or costs only when assessed by a court of competent jurisdiction. Any other provision is invalid and considered null and void
12. **ASSIGNMENT** - Notwithstanding any clause to the contrary, the Agency reserves the right to assign the agreement to another State of West Virginia agency, board or commission upon thirty (30) days written notice to the Vendor and Vendor shall obtain the written consent of Agency prior to assigning the agreement
13. **LIMITATION OF LIABILITY** - The Agency, as a State entity, cannot agree to assume the potential liability of a Vendor. Accordingly, any provision limiting the Vendor's liability for direct damages to a certain dollar amount or to the amount of the agreement is hereby deleted. Limitations on special, incidental or consequential damages are acceptable. In addition, any limitation is null and void to the extent that it precludes any action for injury to persons or for damages to personal property.
14. **RIGHT TO TERMINATE** - Agency shall have the right to terminate the agreement upon thirty (30) days written notice to Vendor. Agency agrees to pay Vendor for services rendered or goods received prior to the effective date of termination
15. **TERMINATION CHARGES** - Any provision requiring the Agency to pay a fixed amount or liquidated damages upon termination of the agreement is hereby deleted. The Agency may only agree to reimburse a Vendor for actual costs incurred or losses sustained during the current fiscal year due to wrongful termination by the Agency prior to the end of any current agreement term
16. **RENEWAL** - Any reference to automatic renewal is hereby deleted. The agreement may be renewed only upon mutual written agreement of the parties.
17. **INSURANCE** - Any provision requiring the Agency to insure equipment or property of any kind and name the Vendor as beneficiary or as an additional insured is hereby deleted
18. **RIGHT TO NOTICE** - Any provision for repossession of equipment without notice is hereby deleted. However, the Agency does recognize a right of repossession with notice.
19. **ACCELERATION** - Any reference to acceleration of payments in the event of default or non-funding is hereby deleted.
20. **CONFIDENTIALITY** - Any provision regarding confidentiality of the terms and conditions of the agreement is hereby deleted. State contracts are public records under the West Virginia Freedom of Information Act
21. **AMENDMENTS** - All amendments, modifications, alterations or changes to the agreement shall be in writing and signed by both parties. No amendment, modification, alteration or change may be made to this addendum without the express written approval of the Purchasing Division and the Attorney General.

ACCEPTED BY:

STATE OF WEST VIRGINIA

Spending Unit: _____

Signed: _____

Title: _____

Date: _____

VENDOR

Company Name: Advanced Alarm Technologies

Signed: [Signature]

Title: President

Date: 8/14/09



State of West Virginia
 Department of Administration
 Purchasing Division
 2019 Washington Street East
 Post Office Box 50130
 Charleston WV 25305-0130

Request for Quotation

RFQ NUMBER
 WSH10002

PAGE
 1

ADDRESS CORRESPONDENCE TO ATTENTION OF:
 ROBERTA WAGNER
 804-558-0067

VENDOR

Earl Moyer
 Advanced Alarm Technologies
 PO Box 4368
 Parkersburg, WV 26104

SHIP TO

HEALTH AND HUMAN RESOURCES
 WILLIAM R. SHARPE JR. HOSPITAL
 CENTRAL RECEIVING
 936 SHARPE HOSPITAL ROAD
 WESTON, WV 26452
 304-269-1210

DATE PRINTED	TERMS OF SALE	SHIP VIA	F.O.B.	FREIGHT TERMS
08/04/2009				
BID OPENING DATE: 08/20/2009				
BID OPENING TIME: 01:30PM				

LINE	QUANTITY	UOP	CAT NO	ITEM NUMBER	UNIT PRICE	AMOUNT
ADDENDUM NO. 3 1. TO MOVE THE BID OPENING DATE FROM 8/18/2009 TO 8/20/2009. 2. ADDENDUM ACKNOWLEDGEMENT IS ATTACHED. THIS DOCUMENT SHOULD BE SIGNED AND RETURNED WITH YOUR BID. FAILURE TO SIGN AND RETURN MAY RESULT IN DISQUALIFICATION OF YOUR BID. EXHIBIT 10 REQUISITION NO.: WSH10002 ADDENDUM ACKNOWLEDGEMENT I HEREBY ACKNOWLEDGE RECEIPT OF THE FOLLOWING CHECKED ADDENDUM(S) AND HAVE MADE THE NECESSARY REVISIONS TO MY PROPOSAL, PLANS AND/OR SPECIFICATION, ETC. ADDENDUM NO. S: NO. 1 <input checked="" type="checkbox"/> NO. 2 <input checked="" type="checkbox"/> NO. 3 <input checked="" type="checkbox"/> NO. 4 <input type="checkbox"/> NO. 5 <input type="checkbox"/> I UNDERSTAND THAT FAILURE TO CONFIRM THE RECEIPT OF TH						

SEE REVERSE SIDE FOR TERMS AND CONDITIONS

SIGNATURE: *Earl Moyer* TELEPHONE: (304) 422-4387 DATE: 8/14/09
 TITLE: President FEIN: 20-2085989 ADDRESS CHANGES TO BE NOTED ABOVE

WHEN RESPONDING TO RFQ, INSERT NAME AND ADDRESS IN SPACE ABOVE LABELED 'VENDOR'

**GENERAL TERMS & CONDITIONS
REQUEST FOR QUOTATION (RFQ) AND REQUEST FOR PROPOSAL (RFP)**

1. Awards will be made in the best interest of the State of West Virginia.
2. The State may accept or reject in part, or in whole, any bid.
3. All quotations are governed by the *West Virginia Code* and the *Legislative Rules* of the Purchasing Division
4. Prior to any award, the apparent successful vendor must be properly registered with the Purchasing Division and have paid the required \$125 fee.
5. All services performed or goods delivered under State Purchase Order/Contracts are to be continued for the term of the Purchase Order/Contracts, contingent upon funds being appropriated by the Legislature or otherwise being made available. In the event funds are not appropriated or otherwise available for these services or goods, this Purchase Order/Contract becomes void and of no effect after June 30.
6. Payment may only be made after the delivery and acceptance of goods or services.
7. Interest may be paid for late payment in accordance with the *West Virginia Code*.
8. Vendor preference will be granted upon written request in accordance with the *West Virginia Code*.
9. The State of West Virginia is exempt from federal and state taxes and will not pay or reimburse such taxes.
10. The Director of Purchasing may cancel any Purchase Order/Contract upon 30 days written notice to the seller.
11. The laws of the State of West Virginia and the *Legislative Rules* of the Purchasing Division shall govern all rights and duties under the Contract, including without limitation the validity of this Purchase Order/Contract.
12. Any reference to automatic renewal is hereby deleted. The Contract may be renewed only upon mutual written agreement of the parties.
13. **BANKRUPTCY:** In the event the vendor/contractor files for bankruptcy protection, the State may deem this contract null and void, and terminate such contract without further order.
14. **HIPAA BUSINESS ASSOCIATE ADDENDUM:** The West Virginia State Government HIPAA Business Associate Addendum (BAA), approved by the Attorney General, and available online at the Purchasing Division's web site (<http://www.state.wv.us/admin/purchase/vrc/hipaa.htm>) is hereby made part of the agreement. Provided that, the Agency meets the definition of a Cover Entity (45 CFR §160.103) and will be disclosing Protected Health Information (45 CFR §160.103) to the vendor.
15. **WEST VIRGINIA ALCOHOL & DRUG-FREE WORKPLACE ACT:** If this Contract constitutes a public improvement construction contract as set forth in Article 1D, Chapter 21 of the West Virginia Code ("The West Virginia Alcohol and Drug-Free Workplace Act"), then the following language shall hereby become part of this Contract: "The contractor and its subcontractors shall implement and maintain a written drug-free workplace policy in compliance with the West Virginia Alcohol and Drug-Free Workplace Act, as set forth in Article 1D, Chapter 21 of the West Virginia Code. The contractor and its subcontractors shall provide a sworn statement in writing, under the penalties of perjury, that they maintain a valid drug-free work place policy in compliance with the West Virginia and Drug-Free Workplace Act. It is understood and agreed that this Contract shall be cancelled by the awarding authority if the Contractor: 1) Fails to implement its drug-free workplace policy; 2) Fails to provide information regarding implementation of the contractor's drug-free workplace policy at the request of the public authority; or 3) Provides to the public authority false information regarding the contractor's drug-free workplace policy."

INSTRUCTIONS TO BIDDERS

1. Use the quotation forms provided by the Purchasing Division.
2. **SPECIFICATIONS:** Items offered must be in compliance with the specifications. Any deviation from the specifications must be clearly indicated by the bidder. Alternates offered by the bidder as **EQUAL** to the specifications must be clearly defined. A bidder offering an alternate should attach complete specifications and literature to the bid. The Purchasing Division may waive minor deviations to specifications.
3. Complete all sections of the quotation form.
4. Unit prices shall prevail in case of discrepancy.
5. All quotations are considered F.O.B. destination unless alternate shipping terms are clearly identified in the quotation.
6. **BID SUBMISSION:** All quotations must be delivered by the bidder to the office listed below prior to the date and time of the bid opening. Failure of the bidder to deliver the quotations on time will result in bid disqualifications: Department of Administration, Purchasing Division, 2019 Washington Street East, P.O. Box 50130, Charleston, WV 25305-0130



State of West Virginia
 Department of Administration
 Purchasing Division
 2019 Washington Street East
 Post Office Box 50130
 Charleston, WV 25305-0130

Request for Quotation

RFQ NUMBER
WSH10002

PAGE
2

ADDRESS CORRESPONDENCE TO ATTENTION OF
ROBERTA WAGNER 304-558-0067

VENDOR	RFQ COPY
	TYPE NAME/ADDRESS HERE

SHIP TO	HEALTH AND HUMAN RESOURCES WILLIAM R. SHARPE JR. HOSPITAL CENTRAL RECEIVING 936 SHARPE HOSPITAL ROAD WESTON, WV 26452	304-269-1210
---------	--	--------------

DATE PRINTED	TERMS OF SALE	SHIP VIA	F.O.B.	FREIGHT TERMS
08/04/2009				

BID OPENING DATE: 08/20/2009 BID OPENING TIME 01:30PM

LINE	QUANTITY	UOP	CAT NO	ITEM NUMBER	UNIT PRICE	AMOUNT
<p>ADDENDUM(S) MAY BE CAUSE FOR REJECTION OF BIDS.</p> <p>VENDOR MUST CLEARLY UNDERSTAND THAT ANY VERBAL REPRESENTATION MADE OR ASSUMED TO BE MADE DURING ANY ORAL DISCUSSION HELD BETWEEN VENDOR'S REPRESENTATIVES AND ANY STATE PERSONNEL IS NOT BINDING. ONLY THE INFORMATION ISSUED IN WRITING AND ADDED TO THE SPECIFICATIONS BY AN OFFICIAL ADDENDUM IS BINDING.</p> <p style="text-align: center;"> <i>Paul H. Hies</i> SIGNATURE <i>Advanced Alarm Technologies</i> COMPANY 8/14/09 DATE </p> <p>REV. 11/96</p> <p style="text-align: center;">END OF ADDENDUM NO. 3</p>						

SEE REVERSE SIDE FOR TERMS AND CONDITIONS

SIGNATURE	TELEPHONE	DATE
TITLE	FEIN	ADDRESS CHANGES TO BE NOTED ABOVE

WHEN RESPONDING TO RFQ, INSERT NAME AND ADDRESS IN SPACE ABOVE LABELED 'VENDOR'

**GENERAL TERMS & CONDITIONS
REQUEST FOR QUOTATION (RFQ) AND REQUEST FOR PROPOSAL (RFP)**

1. Awards will be made in the best interest of the State of West Virginia.
2. The State may accept or reject in part, or in whole, any bid.
3. All quotations are governed by the *West Virginia Code* and the *Legislative Rules* of the Purchasing Division
4. Prior to any award, the apparent successful vendor must be properly registered with the Purchasing Division and have paid the required \$125 fee.
5. All services performed or goods delivered under State Purchase Order/Contracts are to be continued for the term of the Purchase Order/Contracts, contingent upon funds being appropriated by the Legislature or otherwise being made available. In the event funds are not appropriated or otherwise available for these services or goods, this Purchase Order/Contract becomes void and of no effect after June 30.
6. Payment may only be made after the delivery and acceptance of goods or services
7. Interest may be paid for late payment in accordance with the *West Virginia Code*
8. Vendor preference will be granted upon written request in accordance with the *West Virginia Code*.
9. The State of West Virginia is exempt from federal and state taxes and will not pay or reimburse such taxes
10. The Director of Purchasing may cancel any Purchase Order/Contract upon 30 days written notice to the seller
11. The laws of the State of West Virginia and the *Legislative Rules* of the Purchasing Division shall govern all rights and duties under the Contract, including without limitation the validity of this Purchase Order/Contract.
12. Any reference to automatic renewal is hereby deleted. The Contract may be renewed only upon mutual written agreement of the parties
13. **BANKRUPTCY:** In the event the vendor/contractor files for bankruptcy protection, the State may deem this contract null and void, and terminate such contract without further order.
14. **HIPAA BUSINESS ASSOCIATE ADDENDUM:** The West Virginia State Government HIPAA Business Associate Addendum (BAA), approved by the Attorney General, and available online at the Purchasing Division's web site (<http://www.state.wv.us/admin/purchase/vrc/hipaa.htm>) is hereby made part of the agreement. Provided that, the Agency meets the definition of a Cover Entity (45 CFR §160.103) and will be disclosing Protected Health Information (45 CFR §160.103) to the vendor.
15. **WEST VIRGINIA ALCOHOL & DRUG-FREE WORKPLACE ACT:** If this Contract constitutes a public improvement construction contract as set forth in Article 1D, Chapter 21 of the West Virginia Code ("The West Virginia Alcohol and Drug-Free Workplace Act"), then the following language shall hereby become part of this Contract: "The contractor and its subcontractors shall implement and maintain a written drug-free workplace policy in compliance with the West Virginia Alcohol and Drug-Free Workplace Act, as set forth in Article 1D, Chapter 21 of the West Virginia Code. The contractor and its subcontractors shall provide a sworn statement in writing, under the penalties of perjury, that they maintain a valid drug-free work place policy in compliance with the West Virginia and Drug-Free Workplace Act. It is understood and agreed that this Contract shall be cancelled by the awarding authority if the Contractor: 1) Fails to implement its drug-free workplace policy; 2) Fails to provide information regarding implementation of the contractor's drug-free workplace policy at the request of the public authority; or 3) Provides to the public authority false information regarding the contractor's drug-free workplace policy."

INSTRUCTIONS TO BIDDERS

1. Use the quotation forms provided by the Purchasing Division.
2. **SPECIFICATIONS:** Items offered must be in compliance with the specifications. Any deviation from the specifications must be clearly indicated by the bidder. Alternates offered by the bidder as **EQUAL** to the specifications must be clearly defined. A bidder offering an alternate should attach complete specifications and literature to the bid. The Purchasing Division may waive minor deviations to specifications.
3. Complete all sections of the quotation form.
4. Unit prices shall prevail in case of discrepancy.
5. All quotations are considered F.O.B. destination unless alternate shipping terms are clearly identified in the quotation.
6. **BID SUBMISSION:** All quotations must be delivered by the bidder to the office listed below prior to the date and time of the bid opening. Failure of the bidder to deliver the quotations on time will result in bid disqualifications: Department of Administration, Purchasing Division, 2019 Washington Street East, P.O. Box 50130, Charleston, WV 25305-0130



State of West Virginia
 Department of Administration
 Purchasing Division
 2019 Washington Street East
 Post Office Box 50130
 Charleston, WV 25305-0130

Request for Quotation

RFQ NUMBER
 WSH10002

PAGE
 3

ADDRESS CORRESPONDENCE TO ATTENTION OF
 ROBERTA WAGNER
 304-558-0067

VENDOR

RFQ COPY
 TYPE NAME/ADDRESS HERE

SHIP TO

HEALTH AND HUMAN RESOURCES
 WILLIAM R. SHARPE JR. HOSPITAL
 CENTRAL RECEIVING
 936 SHARPE HOSPITAL ROAD
 WESTON, WV
 26452 304-269-1210

DATE PRINTED	TERMS OF SALE	SHIP VIA	F.O.B.	FREIGHT TERMS
08/04/2009				

BID OPENING DATE:

08/20/2009

BID OPENING TIME 01:30PM

LINE	QUANTITY	UOP	CAT NO	ITEM NUMBER	UNIT PRICE	AMOUNT
0001	1	JB		990-22	80,495.00	80,495.00
				ACCESS CONTROL SECURITY SYSTEM		
***** THIS IS THE END OF RFQ WSH10002 ***** TOTAL:						80,495.00

SEE REVERSE SIDE FOR TERMS AND CONDITIONS

SIGNATURE	TELEPHONE	DATE
TITLE	FEIN	ADDRESS CHANGES TO BE NOTED ABOVE

WHEN RESPONDING TO RFQ, INSERT NAME AND ADDRESS IN SPACE ABOVE LABELED 'VENDOR'

**GENERAL TERMS & CONDITIONS
REQUEST FOR QUOTATION (RFQ) AND REQUEST FOR PROPOSAL (RFP)**

1. Awards will be made in the best interest of the State of West Virginia.
2. The State may accept or reject in part, or in whole, any bid
3. All quotations are governed by the *West Virginia Code* and the *Legislative Rules* of the Purchasing Division
4. Prior to any award, the apparent successful vendor must be properly registered with the Purchasing Division and have paid the required \$125 fee.
5. All services performed or goods delivered under State Purchase Order/Contracts are to be continued for the term of the Purchase Order/Contracts, contingent upon funds being appropriated by the Legislature or otherwise being made available. In the event funds are not appropriated or otherwise available for these services or goods, this Purchase Order/Contract becomes void and of no effect after June 30.
6. Payment may only be made after the delivery and acceptance of goods or services.
7. Interest may be paid for late payment in accordance with the *West Virginia Code*
8. Vendor preference will be granted upon written request in accordance with the *West Virginia Code*
9. The State of West Virginia is exempt from federal and state taxes and will not pay or reimburse such taxes.
10. The Director of Purchasing may cancel any Purchase Order/Contract upon 30 days written notice to the seller.
11. The laws of the State of West Virginia and the *Legislative Rules* of the Purchasing Division shall govern all rights and duties under the Contract, including without limitation the validity of this Purchase Order/Contract.
12. Any reference to automatic renewal is hereby deleted. The Contract may be renewed only upon mutual written agreement of the parties.
13. **BANKRUPTCY:** In the event the vendor/contractor files for bankruptcy protection, the State may deem this contract null and void, and terminate such contract without further order.
14. **HIPAA BUSINESS ASSOCIATE ADDENDUM:** The West Virginia State Government HIPAA Business Associate Addendum (BAA), approved by the Attorney General, and available online at the Purchasing Division's web site (<http://www.state.wv.us/admin/purchase/vrc/hipaa.htm>) is hereby made part of the agreement. Provided that, the Agency meets the definition of a Cover Entity (45 CFR §160.103) and will be disclosing Protected Health Information (45 CFR §160.103) to the vendor.
15. **WEST VIRGINIA ALCOHOL & DRUG-FREE WORKPLACE ACT:** If this Contract constitutes a public improvement construction contract as set forth in Article 1D, Chapter 21 of the West Virginia Code ("The West Virginia Alcohol and Drug-Free Workplace Act"), then the following language shall hereby become part of this Contract: "The contractor and its subcontractors shall implement and maintain a written drug-free workplace policy in compliance with the West Virginia Alcohol and Drug-Free Workplace Act, as set forth in Article 1D, Chapter 21 of the West Virginia Code. The contractor and its subcontractors shall provide a sworn statement in writing, under the penalties of perjury, that they maintain a valid drug-free work place policy in compliance with the West Virginia and Drug-Free Workplace Act. It is understood and agreed that this Contract shall be cancelled by the awarding authority if the Contractor: 1) Fails to implement its drug-free workplace policy; 2) Fails to provide information regarding implementation of the contractor's drug-free workplace policy at the request of the public authority; or 3) Provides to the public authority false information regarding the contractor's drug-free workplace policy "

INSTRUCTIONS TO BIDDERS

1. Use the quotation forms provided by the Purchasing Division
2. **SPECIFICATIONS:** Items offered must be in compliance with the specifications. Any deviation from the specifications must be clearly indicated by the bidder. Alternates offered by the bidder as **EQUAL** to the specifications must be clearly defined. A bidder offering an alternate should attach complete specifications and literature to the bid. The Purchasing Division may waive minor deviations to specifications
3. Complete all sections of the quotation form.
4. Unit prices shall prevail in case of discrepancy
5. All quotations are considered F.O.B. destination unless alternate shipping terms are clearly identified in the quotation.
6. **BID SUBMISSION:** All quotations must be delivered by the bidder to the office listed below prior to the date and time of the bid opening. Failure of the bidder to deliver the quotations on time will result in bid disqualifications: Department of Administration, Purchasing Division, 2019 Washington Street East, P.O. Box 50130, Charleston, WV 25305-0130

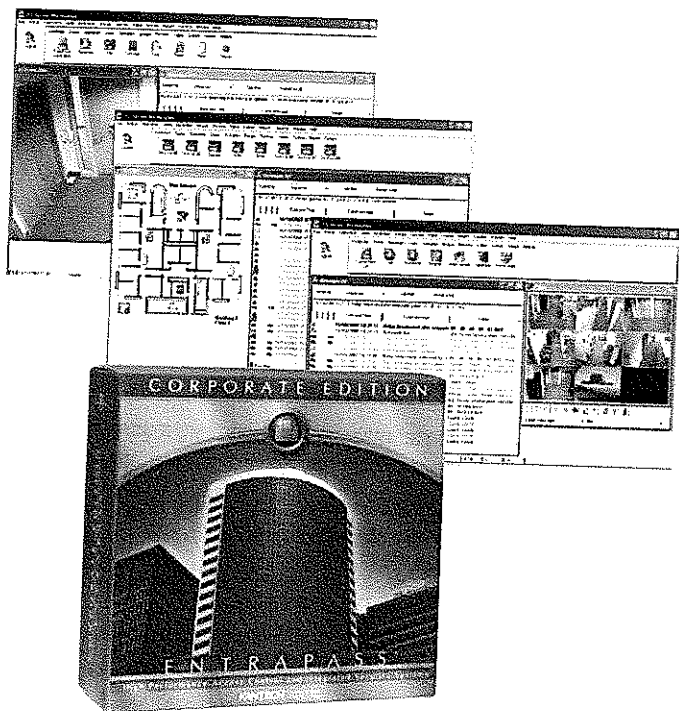

EntraPass Corporate Edition High Performance Access Control and Integrated Security System

Features That Make a Difference:

- Supports up to 20 workstations and controls thousands of doors
- Integrates with American Dynamics™ digital video management systems¹
- Supports Kantech ' IP Link which provides a secure IP solution to operate your access control system more efficiently and securely over a network
- EntraPass workspaces let you control what operators can see based on user privileges
- Update card records quickly and securely with the new EntraPass WebStation
- Display live video, play back recorded video, dispatch, log, and locally save recorded event video
- Eight operator-configurable desktops with unlimited interactive floor plans provide a highly customized experience for each workstation
- Interface with paging systems, HVAC systems and more with innovative SmartLink feature
- Integrated badging solution
- Elevator control for up to 64 doors
- Network-ready architecture lets you easily manage sites remotely
- Supports remote management from central monitoring stations (Managed Access Control)
- Redundancy server and Card Gateway (Oracle/MS SQL HR interface) ensure that critical data is secure even in the event of communication failure (optional)

Kantech EntraPass Corporate Edition is a powerful, multi-user access control system that provides features required even in the most demanding applications. The software adapts easily to meet the needs of growing businesses, allowing users to manage one building or access multiple remote sites from a network.

EntraPass Corporate Edition is extremely easy to install. Express Setup automatically defines all the necessary system components. This innovative feature reduces the time required to configure the system and eliminates programming errors.

EntraPass Corporate Edition distributed system architecture supports connections to remote sites using direct connections

dial-up modems, and TCP/IP communication servers using Kantech IP Link (using Corporate Gateway). Kantech IP Link provides secure communication via 128-bit AES encryption. IP Link is also beneficial to the network infrastructure since communications are sent over the network only since required keeping network traffic down to a minimum.

EntraPass integrates with the American Dynamics Intellex® Digital Video Management System and the American Dynamics EDVR Digital Video Recorder¹. This video integration dramatically increases security by allowing visual observations of monitored areas and allowing security personnel to link an access control event to a video clip directly from their access control application.

⁽¹⁾ Requires v3.1 or higher for Intellex Ultra, DVMS IP v2.6 or higher for Intellex LT and EDVR v1.53

EntraPass Corporate Edition System Capacities

Cards	Unlimited
Card Families or Site Codes	Unlimited
Door Controllers	17,408 per gateway
Card Readers	34,816 per gateway
Keypads	34,816 per gateway
Monitored Points (Inputs)	278,528 (KT-300)
Auxiliary Outputs for Reader	
LEDs and Door Alarms	69,632 (KT-300)
Elevator Floors per Cab	64
Card User Access Levels	250 per site
Access Level Combinations	Unlimited
Schedules of Four Time Zones Each	100/site
Holidays	366 per system
Operator Workstations	20
Gateways	41
System Operator Passwords	Unlimited
Operator Security Levels	Unlimited pre-defined (3)
Concurrent Operator Languages	Two
Number of Printers	One per workstation
Serial Port / USB	Max. 32 per gateway
Remote Sites	Max. 512 per gateway

Recommended Computer Requirements for EntraPass Server⁶

Processor	Pentium® IV 1.8 GHz
RAM	1 GB
Free Hard Disk Space	
Required for Software	20 GB
Screen Resolution	1024 x 768
Graphic Adaptor Card	32 MB
Color Depth	24-bit (16 million colors), required for video integration only
DVD/CD-ROM Drive	48x
Network Interface Card	10/100Base-T
Operating System Compatibility	Windows® 2000, XP, 2003 Standard or Enterprise server, Windows Vista ⁷

Model Number Package Includes:

License for EntraPass Corporate Edition software which enables one server workstation and two additional workstations plus a Corporate Gateway and CBLK-10 cable kit

E-COR-EN-V4	EntraPass Corporate Edition v4.0 software - English
E-COR-SP-V4	EntraPass Corporate Edition v4.0 software - Spanish
E-COR-FR-V4	EntraPass Corporate Edition v4.0 software - French

Manuals Only:

E-COR-MAN-EN	EntraPass Corporate Edition v4.0 English manual
E-COR-MAN-SP	EntraPass Corporate Edition v4.0 Spanish manual
E-COR-MAN-FR	EntraPass Corporate Edition v4.0 French manual

E-COR-UPG-EN-V4	Upgrade for EntraPass Corporate Edition v3.x to v4.0 with English manual
-----------------	--

Accessories:

E-COR-WEB-1	One concurrent EntraPass Webstation connection license for EntraPass Corporate Edition v4.0
E-COR-WEB-3	Three concurrent EntraPass WebStation connection licenses for EntraPass Corporate Edition v4.0
E-COR-WS6	Six additional workstation licenses for EntraPass Corporate Edition v3.0 and higher
E-COR-COM	40 additional Corporate Gateway licenses for EntraPass Corporate Edition v3.0 and higher
E-COR-VVM	Video Vault license for EntraPass Corporate Edition v3.0 and higher
E-COR-RDN	Redundancy server license for EntraPass Corporate Edition v3.0 and higher
E-COR-SQL	Card Gateway license for EntraPass Corporate Edition v3.0 and higher
E-COR-MAC	Account Management (Managed Access Control) license for EntraPass Corporate Edition
E-COR-KTK-1	One Kantech token for EntraPass Corporate Edition
E-COR-KTK-2	Two Kantech tokens for EntraPass Corporate Edition
E-COR-KTK-3	Three Kantech tokens for EntraPass Corporate Edition
E-COR-KTK-5	Five Kantech tokens for EntraPass Corporate Edition
E-COR-KTK-10	10 Kantech tokens for EntraPass Corporate Edition

⁶ Actual requirements may vary based on your operating system and configuration.
⁷ Video functionalities are not supported with Windows Vista.

Product offerings and specifications are subject to change without notice. Actual products may vary from photos. Not all products include all features. Availability varies by region; contact your sales representative. Certain product names mentioned herein may be trade names and/or registered trademarks of other companies.

EntraPass™ Video Integration

Powerful Access Control and Video Integration

Kantech provides a powerful integrated access control and digital video solution with its EntraPass access control software and American Dynamics' Intellex® Digital Video Management System.

By combining the easy-to-use EntraPass interface with the power of Intellex, this integrated solution sets the standard for using digital video with security applications. Customers are able to monitor video real-time through the access control system as well as play back recorded video. This dramatically increases security by providing a link between access control events and pertinent video clips, providing security personnel with video evidence of potential security violations. This integrated solution is made even more powerful with EntraPass Video Vault™, which allows users to automatically archive and password-protect video clips through the EntraPass system.

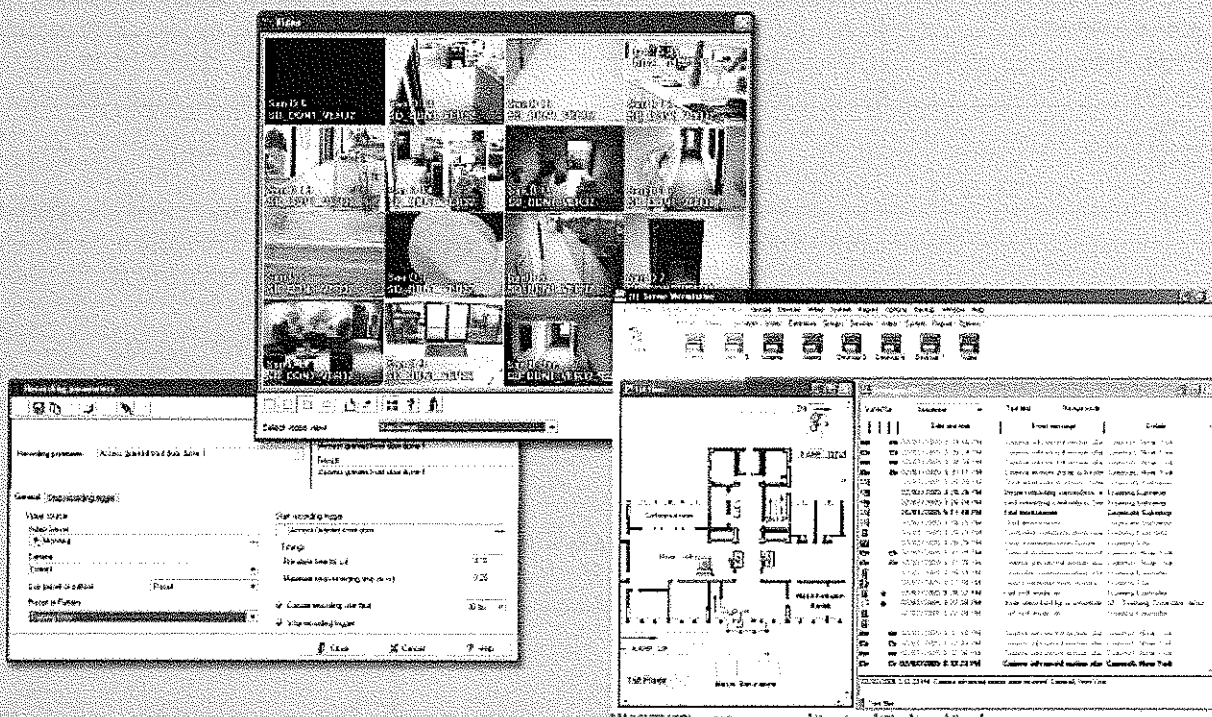

EntraPass™ Video Integration

High performance access control meets revolutionary digital video management.

Enhanced Video Integration

Integration with American Dynamics' Intellex® provides real-time video monitoring as well as video playback. Video can be linked to access events and recorded from 1 to 16 cameras from different Intellex units simultaneously. Different views (1x1, 2x2, 3x3, and 4x4 mode), presets called from any kind of alarm, sequences and dome control are available through the EntraPass software. All cameras can be called up directly from a floor plan simply by double-clicking on the camera icon.

EntraPass Video Vault Option

Get automated archiving for your video clips with EntraPass Video Vault. Installed on your system's network, EntraPass Video Vault offers an alternative to manually saving each video clip one by one.

Simply pre-define groups for your video clips (such as Door Forced; Rejected Card) and Video Vault will save all video to the appropriate group based on whatever schedule you choose. You can also pre-designate which file type you want video

clips saved as- KVI, .KVA, .IMG, or .AVI-and whether these files, if KVI or KVA, are assigned password-protection.

You can also organize your video clips using thumbnail .BMP images in lieu of icons. Select the first frame (taken from the onset of pre-alarm footage), the event frame (which coincides with the precise moment of the alarm), or any other frame within the clip that you prefer. Video Vault can connect to as many Intellex units as you choose to integrate with your EntraPass system and can archive the video that you import from them to as many as 24 digital storage devices

Computer Requirements

(Workstation, Gateway and Server)

Minimum processor	Pentium III 800 MHz
Minimum RAM recommended	256 MB
Minimum free hard disk space	4 GB
Color depth	24-bit (16 million colors)
Network interface card	100Base-T network adapter
Operating system	MS Windows® 98/XP/2000/NT

EntraPass & Intellex Compatibility Chart

	Intellex LT	Intellex DVMS	Intellex RMS	Intellex IP
Number of cameras	4, 8, 16	8, 16 (desktop) 16 (rackmount)	8	16
Maximum images per second	60 ips	120 ips	120 ips	480 ips
Live video	Yes	Yes	Yes	Yes
Number of simultaneous connections	5 (w/ Service Pack 1)	10 (w/ Service Pack 1)	10 (w/ Service Pack 1)	10 (w/ Service Pack 1)
Playback option from events	Yes	Yes	Yes	Yes
Alarm from Intellex to EntraPass using API (motion detection, light change, etc.)	Yes	Yes	Yes	Yes
EntraPass Video Vault compatibility	Yes	Yes	Yes	Yes
Video retrieval and playback	Yes	Yes	Yes	Yes
Individual camera rate adjustment	Yes	Yes	Yes	Yes
Text (POS) and audio feature	Yes	Yes	Yes	Yes
Total maximum storage	3.32 TB	1.46 TB	3.75 TB	3.5 TB

Intellex LT - version 2.6 or higher
 Intellex DVMS- version 3.1 or higher
 Intellex RMS- version 3.1 or higher
 Intellex IP- version 3.2 or higher

Ordering Information

- E-COR-EN*†** License for EntraPass Corporate Edition software which enables one server workstation and two additional workstations, elevator control, remote site management, SmartLink, a Corporate Gateway, CBLK-10 cable kit, and an English manual.
- E-GLO-EN-V3**†** License for EntraPass Global Edition software which enables one server workstation and four additional workstations, a Global Gateway (Windows NCC), Integrated badging, elevator control, SmartLink, CBLK-10 cable kit, and an English manual.
- E-COR-VVM** License for one EntraPass Video Vault for Corporate Edition software.
- E-GLO-VVM-V3** License for one EntraPass Video Vault for Global Edition software.

*For French or Spanish reference manual version, replace "EN" with "FR" or "SP" in part number (E-COR-FR or E-COR-SP)

**For French reference manual version, replace "EN" with "FR" in part number (E-GLO-FR-V3)

† Refer to EntraPass Corporate Edition and EntraPass Global Edition datasheets for additional license options.



Monitor sold separately.

Intellex® Digital Video Management Systems

Features That Make a Difference:

- Gain the ability to multiplex, detect alarms and events, record video, audio and text and much more
- Set dome presets, patterns and configurations right from the Intellex® GUI
- Search for specific clips using video analysis tools and advanced text
- Operate Intellex like a virtual matrix via Network Client[†] with CCTV keyboard-based camera control and an expanded capacity to stream video simultaneously from multiple cameras
- React faster to potential emergencies with immediate email notification of system events and alarms
- Customize camera views for flexible monitoring
- Respond to events with alarm-triggered dome positioning
- Record higher frame rates per second for certain cameras and assign the remainder to less critical cameras
- Easily export video, audio and text to CD-RW or DVD+RW with one click of the mouse
- Store over 9 times more video than MPEG-4 and MJPEG-based systems using patented American Dynamics' Active Content Compression (ACC) technology
- Use 3rd party applications—such as access control from Software House® and Kantech™ as well as video forensics, virtual matrix, remote monitoring and more—integrated with Intellex via the powerful API

Intellex Ultra (available with 16 channels)

Intellex Ultra is a reliable, high performance platform that captures higher resolution, de-interlaced images (4CIF, 240 ips; 2CIF, 480 ips)² without compromising the capability to record full motion video. Its 3U chassis saves expensive rack space, making it an ideal solution for applications like casinos or government facilities with limited space for security equipment. For ultimate flexibility and security, Intellex Ultra has up to four front-accessible, swappable 3.5 inch hard drive bays which can optionally be used in a RAID 5 configuration. Plus, an industry first, separate, solid-state, embedded system drive means no moving parts to wear out or fail.

Intellex IP (up to 16 network video streams)

Intellex IP supports IP cameras with performance of up to 480 ips at 1CIF and 120 ips at 4CIF. Intellex IP integrates seamlessly with existing Intellex systems and analog and digital cameras to leverage prior investments. Its scalable 1U form factor complements the design of large systems. The ability to use existing IT network cable further reduces total cost of ownership.

Intellex DVMS (available with 8 and 16 channels)

The original digital video management system, Intellex DVMS has been leading the market since 1997. Intellex DVMS offers a 16-channel system that records up to 120 ips at 2CIF. Intellex DVMS is offered in a desktop or rack mount chassis with Standard, Deluxe and Premier packages. This means simplified packaging for easier ordering, maintenance and configuration. And because Intellex DVMS is networkable and easily integrates with other equipment and software applications, it's a cost-effective solution for many new and existing applications.

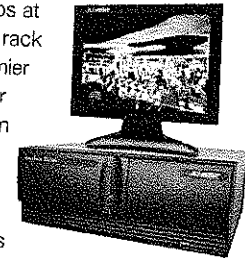

Intellex LT (available with 4, 8 and 16 channels)

Intellex LT delivers the key Intellex features in an economical package, providing the best solution for small retail stores, health care facilities and small offices. It can store more than 900 hours of video and supports as many as five simultaneous Network Client users.

(1) Requires v4.0 or higher.

(2) All ips measurements reflect NTSC format. 120 ips NTSC = 100 ips PAL.

Remote Accessibility Offers the Most Flexible Viewing

With Browser Client, you can host and customize your own website to provide live viewing of Intellex video through a standard browser interface. Multiple clients can access and even control domes remotely through Browser Client, which is available at no charge. If more advanced operations are required, Network Client allows you to remotely configure Intellex, select video segments by time, date or alarm, use Smart Search, view up to 64 simultaneous live video segments and have virtual matrix capability⁹ when used with a CCTV keyboard. Save, annotate and organize copied video into incident folders to aid with investigations. Export video clips to an .AVI file to play on any Windows[®]-based PC. For more information on these and other Intellex tools, such as Intellex Archive Manager and Intellex Policy Manager, please refer to our separate Intellex Management Suite data sheet.

Intellex Web Server Provides Live Video Over the Web

The Intellex web server component allows you to view live video via a web page at 4CIF. Users enter a password to log on to the server, which ensures that only authorized personnel access the video. In addition, users have PTZ control of dome cameras from the web server.

Optimize the Settings to Fit Your Specific Needs

Record duration, or the quantity of images that can be recorded on hard drives, is affected by several factors. Digital video with high levels of activity or detail consumes more disk space than video with little activity or detail. Choose from super, extended record and normal settings to balance image quality against record duration. For longer record durations, simply reduce your resolution settings. Use Auto Rate mode with Intellex Ultra, DVMS and LT to set equal frame rates for each camera or adjust the recording frame rate per camera.

Customize Views with Multi-Camera Playback and Display

Select live and playback displays for any camera in any position in 1x1, 2x2, 3x3 or 4x4 picture formats. In live camera display and playback, choose Full Screen mode to hide the controls and fill the entire screen or Menu mode to display the control interface. Play back video segments at a variety of speeds in forward or reverse sequence.

Take a Closer Look for Superior Analysis

Choose any live or recorded picture area and zoom in 2X to 16X for a closer look. Digitally enhance the color, contrast

and sharpness of events. Easily navigate or move around in the enlarged picture for a quick, magnified look at all details.

Respond More Quickly for Better Security

Respond to potential emergencies more quickly with automated email notification. You can configure specific types of events that register on your Intellex (such as drive failure) and cameras (such as motion detection alarms) as email triggers that generate and send a message to a pre-defined distribution list.

Upgradable, Expandable Platforms Provide Room to Grow

Keep your system up-to-date with software upgrades easily installed from digital media or via the web. In addition, each Intellex DVMS and LT system can connect to up to three Extended Storage Modules (ESM) to expand the local storage capacity. Intellex Ultra provides up to 2.0 TB of internal storage capacity and supports SAN and NAS devices including the American Dynamics RAID Storage System for extended storage, as does Intellex IP.

Best Video Compression in the Industry Saves Significant Space, Money and Bandwidth

Unlike MPEG-4 and MJPEG, the patented American Dynamics Active Content Compression (ACC) technology was developed specifically for security applications and can differentiate between true motion and video noise. This allows images to be compressed into files that are one ninth the size they would be if compressed with MPEG-4 technology, which means you will use far less disk space. In fact, images compressed using ACC can save you up to \$69,000¹⁰ over a 30-day period when you factor in the additional space you would have to purchase for storing MPEG-4 images.

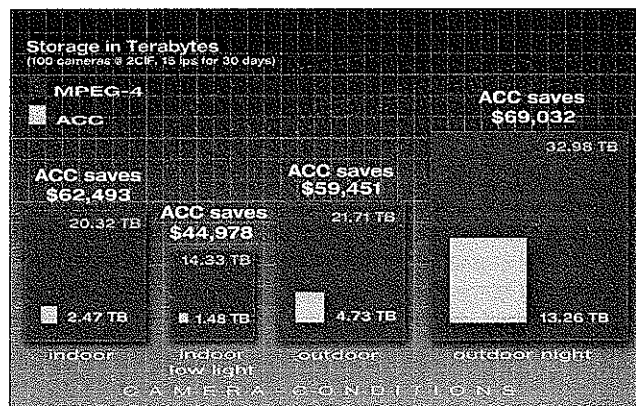

⁹ Sold separately.

¹⁰ Estimated savings with ACC compression is based on the industry average of \$3,500.00 (USD) per TB.

take a closer look

Secure Your System with Covert Cameras and Activity Logs

Intellex lets you configure up to 15 cameras for local covert operation, restricting their use to only those who are authorized. To everyone else, covert cameras register on the status screen as being disconnected. For additional security, monitor every action performed on your Intellex. Activity logging can list the user name of each person who uses the system along with the date, time and task they completed.

Intellex Management Software and Accessories

From Network Client Remote Management Software to RAID Storage Systems, American Dynamics offers a full suite of accessories to enhance the power of your Intellex digital video management system. For complete descriptions and model numbers, please refer to the Intellex Management Suite and Intellex Accessories data sheets on our website.

Model Number Configuration for Intellex IP

	BRAND	FAMILY	PLATFORM	STORAGE
EXAMPLE	AD	D	IP	050
IP	AD	Digital Video Management Systems	IP = IP	050 = 500 GB 100 = 1.0 TB

Basic System Diagram

Whatever platform you choose, Intellex lets you customize your system. Add PTZ cameras and SpeedDome programmable dome cameras and operate them with the ADTT16E Touch Tracker Controller. Display video on a variety of monitors, integrate I/O alarm devices, stream in audio or ASCII text from cash registers. Even add a printer. Need more storage capacity? Install up to three Extended Storage Modules (ESMs) for each Intellex DVMS or LT or use standard SAN, NAS or DAS devices for Intellex Ultra and Intellex IP. Want to integrate your video with third party software? Intellex API provides a powerful yet easy to use set of programming interfaces that enable interoperability with access control and business management software applications.

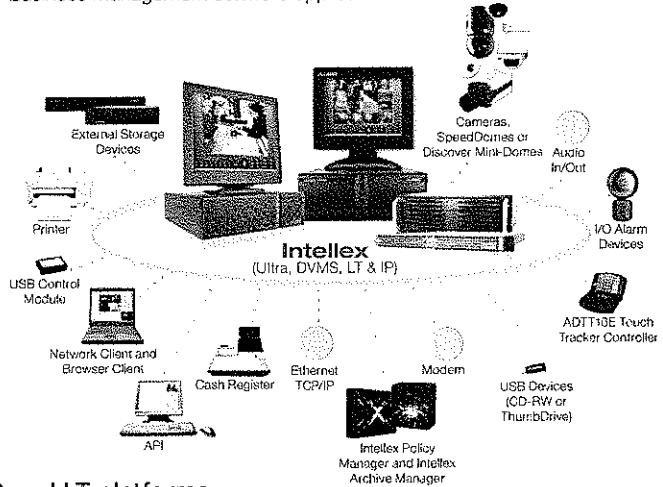

Model Number Configuration for Intellex Ultra, DVMS and LT platforms

	BRAND	FAMILY	CHANNELS	CHASSIS	PLATFORM	FEATURES	STORAGE
EXAMPLE	AD	D	6	00	UL	P	150
ULTRA	AD	Digital Video Management Systems	6 = 16 channels	00 = Desktop/ Rack Mount configurable	UL = Ultra UR = Ultra RAID ⁽¹⁾	P = Premier	050 = 500 GB 100 = 1 TB 150 = 1.5 TB 200 = 2.0 TB
EXAMPLE	AD	D	6	00	DV	S	025 ⁽²⁾
DVMS			8 = 8 channels 6 = 16 channels	00 = Desktop R0 = Rack Mount	DV = DVMS	S = Standard D = Deluxe P = Premier	016 = 160 GB 025 = 250 GB 075 = 750 GB 032 = 320 GB
EXAMPLE	AD	D	4	00	LT	D	016
LT			4 = 4 channels 8 = 8 channels 6 = 16 channels	00 = Desktop	LT = LT	D = Deluxe P = Premier	016 = 160 GB 032 = 320 GB

(1) RAID configuration only available with 1.5 TB storage.

(2) 160 GB and 320 GB models are available in Standard Edition only; 250 GB and 500 GB are available in Deluxe and Premier Editions only; 750 GB model is available in Deluxe and Premier rack mount chassis only.



SPECIFICATIONS

	Intellex Ultra	Intellex DVMS	Intellex LT	Intellex IP
General				
Drive Type	Front Access SATA	Internal SATA	Internal SATA	Internal SATA
Exporting	CD-RW or DVD+RW	CD-RW or DVD+RW ⁽¹³⁾	CD-RW 1.4 MB diskette drive	CD-RW or DVD+RW
Local Archiving (Optional)	External DAT tape (20 GB) SDLT (160 GB)	External DAT tape (20 GB) SDLT (160 GB)	N/A	N/A
Video Standard	NTSC/PAL	NTSC/PAL	NTSC/PAL	N/A
Video Inputs	16	8 (non-looping) or 16 (looping)	4 & 8 (non-looping) or 16 (looping)	Up to 16 network video streams
Main Monitor Output	SVGA Composite	SVGA	SVGA	SVGA
Analog Output	Call/Spot ⁽¹⁴⁾	Call/Spot ⁽¹⁴⁾ Live/Playback ⁽¹⁵⁾	Call/Spot ⁽¹⁴⁾ Live/Playback ⁽¹⁵⁾	N/A
Camera Looping Outputs	16 with optional looping panel	Standard on 16-channel system	Standard on 16-channel system	N/A
Alarm Inputs and Outputs ⁽¹⁶⁾	16 (toolless)	8 16	4 8 16	16 via network device
Single Channel Audio	Included	Premier	Premier	5 1 USB adapter included
IEEE 1394 (FireWire)	N/A	Deluxe Premier only	Deluxe Premier only	N/A
Network	2x gigabit	1x 100Base-T	1x 100Base-T	2x gigabit
USB (front/back)	2/2	2/4	2/4	2/2
Serial Port (RS-232) ⁽¹⁷⁾	1x DB 9	1x DB 9	1x DB 9	1x DB 9
SCSI Interface	Optional	Optional	Optional	Optional
Visual Indicators	Power, alarm, record, disk available, disk activity	Power alarm record	Power alarm record	Power disk activity
Mouse	PC mouse included as standard	PC mouse included as standard	PC mouse included as standard	PC mouse included as standard
Printer	PC printer compatibility	PC printer compatibility	PC printer compatibility	PC printer compatibility ⁽¹⁹⁾
Physical				
	Desktop/Rack Mount Configurable	Desktop Model	Desktop Model only	Rack Mount only
Dimensions (H x W x D)	130 x 429 x 546 mm (5.125 x 16.895 x 21.5 in)	172 x 432 x 464 mm (6.75 x 17.0 x 18.25 in)	172 x 432 x 464 mm (6.75 x 17.0 x 18.25 in)	43 x 447 x 546 mm (1.68 x 17.60 x 21.50 in)
Unit Weight	17.3 kg (38 lbs)	14.50 kg (31.90 lbs)	14.50 kg (31.90 lbs)	11.80 kg (26 lbs)
Shipping Weight	25 kg (55 lbs)	16.93 kg (37.25 lbs)	16.93 kg (37.25 lbs)	18.14 kg (40 lbs)
		Rack Mount Model		
Dimensions (H x W x D)		175 x 432 x 521 mm (6.875 x 17.0 x 20.5 in)		
Unit Weight		20.39 kg (44.95 lbs)		
Shipping Weight		27.24 kg (60.05 lbs)		

Common Specifications for Intellex Digital Video Management Systems

Environmental		Regulatory ⁽¹⁸⁾	
Operating Temperature	5° to 35°C (41° to 95°F)	Emissions	FCC 15b Class B EN55022 (1995) Class A EN61000-3-2 (1995) EN61000-3-3 (1995)
Humidity	5% to 95% RH (noncondensing)	Immunity	EN50130-4 (1996)
Storage Conditions	-10° to 60°C (14° to 140°F)	Safety	UL 60950-1 EN 60950-1: 2001+A11
Maximum Operating Altitude	3 048 m (10,000 ft)		
Electrical			
Power	100-240 VAC 50/60 Hz 3.0/1.5 A		

(13) CD-RW is only available in the Standard and Deluxe Editions; DVD+RW is only available in the Premier Edition.
 (14) Call mode displays video from one selected camera in single pane format; spot mode automatically switches from this camera to any alarmed cameras. Available on 16-channel systems only.
 (15) Live/Playback composite output can display the same video as your Intellex monitor or display live video only.
 (16) Two part connector—FTL inputs, Open collector outputs.
 (17) Jack (3.5 mm).
 (18) On board serial port recommended for multiplexer control. Additional serial port available in Premier Edition via USB converter.
 (19) No parallel port (USB or Ethernet only).
 (20) Certification available upon request.

Product offerings and specifications are subject to change without notice. Actual products may vary from photos. Not all products include all features. Availability varies by region; contact your sales representative. Certain product names mentioned herein may be trade names and/or registered trademarks of other companies.

© 2007 Sensormatic Electronics Corporation. All rights reserved. AD0005-DS-200708-R05-LT-EN

www.americandynamics.net



Camclosure® IS Series Rugged Mini Dome

IS110 SERIES SURFACE MOUNT, WDR, DAY/NIGHT, HIGH RESOLUTION

Product Features

- Fully-Integrated Enclosure with Camera and Lens
- Rugged, High-Impact, Vandal-Resistant, Puncture-Proof Domes; Tamper-Resistant Hardware
- 4 Camera Options:
 - Day/Night Wide Dynamic Range (WDR): Pixel-Based Imager for Accurate Color Representation, Progressive Scan
 - Day/Night High Resolution: 540 TVL
 - Wide Dynamic Range (WDR): Pixel-Based Imager for Accurate Color Representation, Progressive Scan
 - High Resolution Color: 540 TVL
- Varifocal Lens Options: 3.0-9.5 mm, 9.0-22.0 mm
- Includes Both Composite and Unshielded Twisted Pair (UTP) Outputs
- 12 VDC or 24 VAC Operation, Autosensing
- Available with Smoked or Clear Bubble
- Service Connector for Video Output

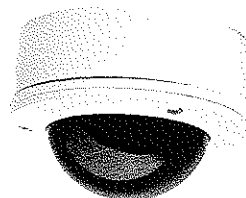

IS110 SERIES DOME

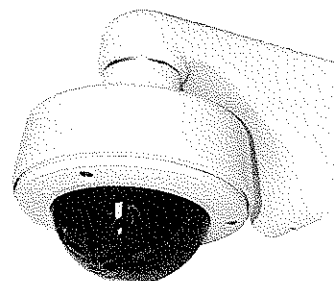

IS110 SERIES DOME WITH ICS110-PG PENDANT ADAPTER AND SWM-GY MOUNT

Camera Modules

The **IS110 Series Camclosure® Integrated Camera System** offers a large selection of camera and lens options. Available camera modules include:

- **Day/night wide dynamic range (WDR) and wide dynamic range:** Pelco's WDR uses a pixel-based imager that adjusts for lighting by pixel. Traditional CCD cameras adjust the entire image for lighting conditions that appear in a small portion of the image or lighting conditions that are not extreme. Different lighting problems occur at night; car headlights and parking lot lights are good examples of problematic video images. Use Pelco's Day/Night WDR where you need the camera to adjust from extreme lighting to low light conditions.
- **Day/night high resolution (540 TVL) color camera with auto iris, varifocal lens:** Application examples include environments that require monochrome images at night and color images during the day.
- **High resolution (540 TVL) color camera with auto iris, varifocal lens:** Application examples include all general-purpose environments.

Enclosure Module

The **IS110 Series Camclosure Integrated Camera System** combines an environmental cover, back box, camera, lens, and lower dome into a small, high-security system that is quick and easy to install. The system is perfect for a variety of indoor and outdoor applications and its versatile design allows for multiple mounting options.

The **IS110 Series** can be installed directly into a ceiling or wall or to a 1.5-inch (3.81 mm) NPT fitting with the optional pendant mount adapter (ICS110-PG). The unit can also mount directly to a 4S electrical box using the optional adapter plate (ICS110-AP) or a standard plaster ring.

The system's back box has three conduit openings: two in the base and a threaded 0.75-inch (1.91 cm) opening in the side. The environmental cover can be used to hide and protect the side conduit opening if it is not used.



C3426 / REVISED 1-28-09

IP66



U.S. Patents D476 025; 6 715 939 B2; 6 805 498 B2

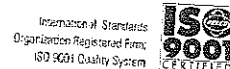

TECHNICAL SPECIFICATIONS

GENERAL

Construction	Aluminum with steel camera mounting bracket and polycarbonate dome
Finish	Light gray polyester powder coat
Light Attenuation	f/1.5 light loss
Smoked	Zero light loss
Clear	
Unit Weight	2.20 lb (1.00 kg)
Shipping Weight	4.0 lb (1.81 kg)

ELECTRICAL

Input Voltage*	12 VDC or 24 VAC ($\pm 10\%$) autosensing
Synchronization	Internal or AC line lock
Power Consumption	<3 W (DW/CW models)
Camera	<4 W (DN/CH models)
Heaters	10 W when active; thermostatically controlled

MECHANICAL

Cable Entry	One 0.75-inch (1.91 cm) NPT threaded opening on side; two 0.75-inch (1.91 cm) openings on base
Pan/Tilt Adjustment	Manual
Pan	360°
Tilt	80° (20° to 100° range)
Rotation	360°

VIDEO

Signal System	NTSC or PAL
Video Output	1 Vp-p, 75 ohms
Composite	1 Vp-p, 100 ohms
UTP	1 composite BNC and 1 UTP
Video Connectors	3-conductor, 2.5 mm connector for video output to optional IS-SC cable
Service Connector	

ENVIRONMENTAL

Environment	Low temperature, indoor/outdoor
Operating Temperature	-50° to 122°F (-46° to 50°C); de-ices to 25°F (-4°C)
Thermostat Operation	Heater is thermostatically controlled to activate ON at 50°F (10°C) and OFF at 80°F (27°C)

CERTIFICATIONS/RATINGS/PATENTS

- CE, Class B
- FCC, Class B
- UL/cUL Listed
- C-Tick
- GOST
- Meets NEMA Type 4X and IP66 standards
- IEC 60068-2-27 Shock Certified
- IEC 60068-2-30 Humidity Certified
- IEC 60068-2-6 Vibration Certified
- ISTA Shipping Standard
- U.S. Patents D476 025; 6 715 939 B2; 6 805 498 B2

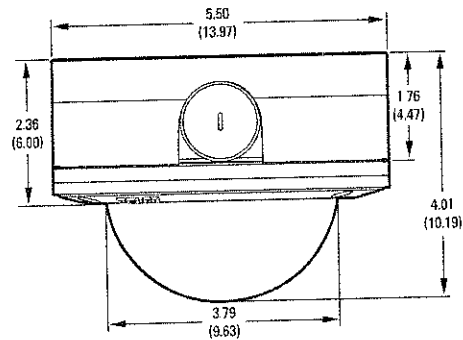

NOTE: VALUES IN PARENTHESES ARE CENTIMETERS; ALL OTHERS ARE INCHES.

*24 VAC power is recommended when installing any Camclosure Integrated Camera System under fluorescent lighting conditions

TECHNICAL SPECIFICATIONS

CAMERA SPECIFICATIONS

	Day/Night Wide Dynamic Range Varifocal, Auto Iris (DW Series)	Day/Night High Resolution Varifocal, Auto Iris (DN Series)	Wide Dynamic Range Varifocal, Auto Iris (CW Series)	High Resolution Varifocal, Auto Iris (CH Series)
Imaging Device	1/3-inch pixel based imager	1/3-inch interline color CCD	1/3-inch pixel based imager	1/3-inch interline color CCD
Picture Elements	720 (H) x 540 (V)	NTSC: 768 (H) x 494 (V) PAL: 752 (H) x 582 (V)	720 (H) x 540 (V)	NTSC: 768 (H) x 494 (V) PAL: 752 (H) x 582 (V)
Dynamic Range (DW/CW only)	102 dB typical 120 dB maximum	—	102 dB typical 120 dB maximum	—
Scanning System	2:1 interlace/ progressive (DIP switch)	2:1 interlace	2:1 interlace/ progressive (DIP switch)	2:1 interlace
Horizontal Resolution	NTSC: 504 TV lines PAL: 504 TV lines	NTSC: 540 TV lines PAL: 540 TV lines	NTSC: 504 TV lines PAL: 504 TV lines	NTSC: 540 TV lines PAL: 540 TV lines
Signal-to-Noise Ratio	>53 dB	>50 dB	>53 dB	>50 dB
Minimum Illumination	Color (day): 0.8 lux SENS 8X: 0.2 lux B-W (night): 0.08 lux SENS 8X: 0.02 lux (f/1.0, 40 IRE, AGC on 75% scene reflectance 3.0-9.5 mm lens)	Color (day): 0.15 lux B-W (night): 0.015 lux (f/1.0, 40 IRE, AGC on 75% scene reflectance 3.0-9.5 mm lens)	Color (day): 0.8 lux SENS 8X: 0.2 lux (f/1.0, 40 IRE, AGC on 75% scene reflectance 3.0-9.5 mm lens)	0.3 lux (f/1.0, 40 IRE, AGC on 75% scene reflectance 3.0-9.5 mm lens)
Day/Night Operation				
Day	Infrared (IR) cut filter	Infrared (IR) cut filter and optical low pass filter	—	—
Night	No filter	Optical low pass filter	—	—
Filter Switch Threshold	Dusk 4 lux Dark 1 lux	0.15 lux	—	—
Gain Control	Auto (36 dB maximum)	Auto/Manual (DIP switch)	Auto (36 dB maximum)	Auto/Manual (DIP switch)
Exposure	Auto (1/15-1/22 000)	Auto (1/60-1/100 000)	Auto (1/15-1/22 000)	Auto (1/60-1/100 000)
White Balance	Auto or manual (DIP switch) 2800°K-7500°K	Auto or manual (DIP switch) 2500°K-9500°K	Auto or manual (DIP switch) 2800°K-7500°K	Auto or manual (DIP switch) 2500°K-9500°K
Backlight Compensation	Auto	ON/OFF (DIP switch)	Auto	ON/OFF (DIP switch)

LENS SPECIFICATIONS

Series	Varifocal with Auto Iris			
	DW/CW Series		DN/CH Series	
Focal Length	3.0-9.5 mm	9.0-22.0 mm	3.0-9.5 mm	9.0-22.0 mm
Format Size	1/3-inch	1/3-inch	1/3-inch	1/3-inch
F-Number (f)	1.0-1.7	1.5-3.0	1.0-1.7	1.5-3.0
Operation				
Iris	Auto	Auto	Auto	Auto
Focus	Manual	Manual	Manual	Manual
Zoom	Manual	Manual	Manual	Manual
Angle of View*				
Horizontal	100.4° to 31.6°	32.4° to 13.6°	95.0° to 30.2°	30.6° to 13.0°
Diagonal	131.6° to 39.6°	41.4° to 17.2°	123.6° to 37.6°	39.2° to 16.4°
Vertical	72.8° to 23.8°	23.8° to 10.2°	69.0° to 22.6°	22.6° to 9.8°

*Focal length specifications presume a 10% horizontal and 4% vertical monitor overscan

SYSTEM MODELS AND ACCESSORIES

MODEL NUMBERS

Dome Only

IS110-ENC IS110 Series surface mount enclosure (no camera/lens)
 IS110-LD IS110 Series smoked bubble
 IS111-LD IS110 Series clear bubble with liner

When ordering an IS110 Series surface mount dome with no camera or lens please order 1 enclosure and 1 bubble

System Numbers

Use this table to create a model number to specify your IS110 Series Camclosure. Note the additional information in the table below for NTSC/PAL options. For example, IS111-DNV9X is the model number for a PAL version color day/night high resolution camera with a clear bubble and a 3.0-9.5 mm varifocal lens. For information contact your Pelco sales representative.

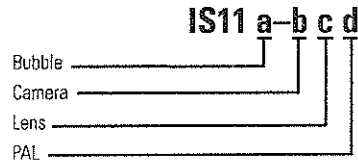

Bubble (a)	Camera (b)	Lens (c)	PAL (d)
0 Smoked	DW Color Day/Night Wide Dynamic Range	V9 Varifocal 3.0-9.5 mm Auto Iris	DN and CH cameras only. X PAL
1 Clear with black liner	DN Color Day/Night High Resolution CW Color Wide Dynamic Range CH Color High Resolution	V22 Varifocal 9.0-22.0 mm Auto Iris	Do not use for NTSC

RECOMMENDED POWER SUPPLIES

TF2000 Power supply for one 24 VAC camera 20 VA
 MCS Series Multiple 24 VAC camera power supply indoor
 MCS*E Series Multiple 24 VAC camera power supply indoor
 WCS Series Single/multiple 24 VAC camera power supply outdoor

OPTIONAL ACCESSORIES

ICS110-AP Adapter plate for a 4-square electrical box
 ICS110-PG Pendant mount adapter
 ICS110-BV Breather vent to prevent condensation from forming inside the unit
 SWM Series Compact wall mount with cable feedthrough
 Requires ICS110-PG adapter
 IS-SC 4-foot service/monitor cable; compatible with any standard monitor BNC connector



Pelco, Inc. Worldwide Headquarters:
 3500 Pelco Way, Clovis, California 93612-5699 USA
USA & Canada Tel: (800) 289-9100 • FAX: (800) 289-9150
International Tel: +1 (559) 292-1981 • FAX: +1 (559) 348-1120
www.pelco.com

Pelco, the Pelco logo, and Camclosure are registered trademarks of Pelco, Inc. All product names and services identified throughout this document are trademarks or registered trademarks of their respective companies. The absence of a trademark or registered trademark from this document does not constitute a waiver of intellectual property rights. Product specifications and availability subject to change without notice.
 ©Copyright 2009 Pelco, Inc. All rights reserved.