



Request for Quotation PTR10035 – Pre-Engineered Bus Passenger Shelters

Due April 1, 2010 @ 1:30pm



Brasco International, Inc.

1000 Mt. Elliott

Detroit, MI 48207

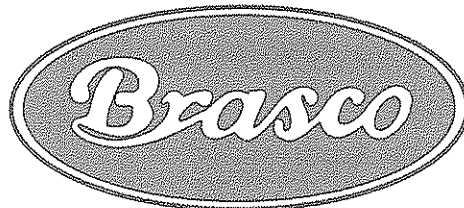

Contact: Sean Loewe

Phone: (800) 893-3665 Fax: (313) 893-3665 Email: sloewe@brasco.com

RECEIVED

2010 APR -1 A 8:05

PROCUREMENT DIVISION
STATE OF WV

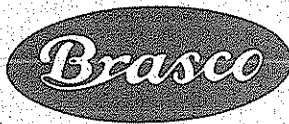

BRASCO

INTERNATIONAL

March 29, 2010

Frank Whittaker
Department of Administration
Purchasing Division
2019 Washington Street East
Charleston, WV 25305-0130

1000 Mt. Elliott
Detroit, MI 48207
PHONE: (800) 893-3665
FAX: (313) 393-0499
WEB: www.brasco.com

Re: Request for Quotation #PTR10035, Pre-Engineered Bus Passenger Shelters

Brasco International, Inc. is pleased to submit the attached bid for Pre-Engineered Bus Passenger Shelters according to the specifications set out in the request for quotations.

Brasco International, Inc. is in the business of providing quality shelters to the transit industry and has been doing so since 1984. Our dedicated staff has a combined résumé covering all aspects of the shelter industry from the design through the final fabrication.

Brasco is fully compliant with all the requirements set out in the request for quotations and addendum #1 - #5. Brasco's shelter specifications for this project are identical to those found in the bid specifications. I have included floor plan/elevation drawings detailing these specifications. I have also included similar shelter photos for your reference.

Brasco is a responsible manufacturer with the highest quality passenger waiting shelters and great service. We have adequate financial resources to perform the contract and we hold ourselves accountable to have the most satisfactory record of performance, integrity, and business ethics. Brasco has the necessary engineering skills, technical equipment, experience, production output, and the highest skilled fabricators to complete the contract. We have provided references of our satisfied clientele as well for additional support.

We pride ourselves in the delivery of top quality shelters to top quality customers. We appreciate the opportunity to provide this proposal and look forward to working with you and your staff on this project. If you have any questions or require additional information please do not hesitate to give me a call.

Sincerely yours,

Sean Loewe
Sales, Brasco International, Inc.
1000 Mt. Elliott
Detroit, MI 48207
Phone: (800) 893-3665
Fax: (313) 393-0499
Email: sloewe@brasco.com



Request for Quotation PTR10035 – Pre-Engineered Bus Passenger Shelters

Table of Contents

Table of Contents.....	Page 1
Addenda.....	Page 2
RFQ Documents.....	Page 7
Specifications.....	Page 12
Pricing Form.....	Page 17
Certifications.....	Page 20
Point of Contact, Warranty, and DBE – Good Faith Efforts.....	Page 28
References.....	Page 31
Concrete Pad Specifications.....	Page 37
Installation Instructions and Product Care Guide.....	Page 39
Shelter Elevation/Floor Plan Drawings.....	Page 47
Photos of Similar Products.....	Page 66
Miscellaneous – Solar Lighting, I-Stop, Perforated Panels, Bench, etc.....	Page 75
Color Chart.....	Page 93



State of West Virginia
 Department of Administration
 Purchasing Division
 2019 Washington Street East
 Post Office Box 50130
 Charleston, WV 25305-0130

Request for Quotation

RFQ NUMBER:
PTR10035

PAGE:
1

ADDRESS CORRESPONDENCE TO ATTENTION OF:
FRANK WHITTAKER
304-558-2316

***A19154957** 800-893-3665
BRASCO INTERNATIONAL INC
1000 MT ELLIOTT
DETROIT MI 48207-3426

DIVISION OF PUBLIC TRANSIT
BUILDING 5, ROOM 906
1900 KANAWHA BOULEVARD, EAST
CHARLESTON, WV
25305-0432 304-558-0428

DATE PRINTED	TERMS OF SALE	SHIP VIA	F.O.B	FREIGHT TERMS
03/02/2010	Net 30	Best Way	Destination	Included

BID OPENING DATE: 03/16/2010 BID OPENING TIME: 01:30PM

LINE	QUANTITY	UOP	CAT NO	ITEM NUMBER	UNIT PRICE	AMOUNT
***** ADDENDUM NO. 1 *****						
THIS ADDENDUM IS ISSUED TO PROVIDE THE ATTACHED TECHNICAL QUESTIONS AND ANSWERS.						
BID OPENING DATE AND TIME HAVE NOT CHANGED.						
0001	1	PM		395-30-99-001		
PRE-ENGINEERED BUS PASSENGER SHELTERS						
***** THIS IS THE END OF RFQ PTR10035 ***** TOTAL:						

RECEIVED
MAR 08 2010
 BY:.....

SEE REVERSE SIDE FOR TERMS AND CONDITIONS

SIGNATURE: *Seo* TELEPHONE: 800-893-3665 DATE: 3/12/10

TITLE: Sales FEIN: 38-3156752 ADDRESS CHANGES TO BE NOTED ABOVE

WHEN RESPONDING TO RFQ, INSERT NAME AND ADDRESS IN SPACE ABOVE LABELED 'VENDOR'

PTR10035
Responses to Technical Questions

1. Are permits needed for shelter installation? **The vendor will not have to supply permits. This is up to the transit system.**
2. Are there any shelter removals in Scope? **NO, once again the transit system will be responsible.**
3. We are concern about installing all over the state of West Virginia, how many cities (municipalities) are involved? **See section 2.5 of the specs of the RFQ for clarification. Transit system responsibility.**
4. Was there a prior bus shelter contract in place? **Yes** If so, who held the contract? **Tolar Mfg.** How many shelters were purchased? **200+, please refer to page page 2 of the RFQ concerning quantities.**
5. Are we able to provide pricing based on a minimum of 10 shelters at a time to maximize Production and Freight? **No. Please refer to page 2 of the RFQ concerning quantities.**
6. Is there any room for storing inventory of any shelters? **Question is unclear. All shelters will be shipped to each address of the transit system. They will have proper storing space for the shelters until they install them.**



State of West Virginia
 Department of Administration
 Purchasing Division
 2019 Washington Street East
 Post Office Box 50130
 Charleston, WV 25305-0130

**Request for
 Quotation**

RFQ NUMBER:
PTR10035

PAGE:
1

ADDRESS CORRESPONDENCE TO ATTENTION OF:
**FRANK WHITTAKER
 304-558-2316**

*A19154957 800-893-3665
 BRASCO INTERNATIONAL INC
 1000 MT ELLIOTT
 DETROIT MI 48207-3426

DIVISION OF PUBLIC TRANSIT
 BUILDING 5, ROOM 906
 1900 KANAWHA BOULEVARD, EAST
 CHARLESTON, WV
 25305-0432 304-558-0428

DATE PRINTED	TERMS OF SALE	SHIP VIA	F.O.B.	FREIGHT TERMS
03/15/2010	Net 30	Best Way	Destination	Included

BID OPENING DATE: 03/25/2010 BID OPENING TIME 01:30PM

LINE	QUANTITY	UOP	CAT NO	ITEM NUMBER	UNIT PRICE	AMOUNT
***** ADDENDUM NO. 2 *****						
THIS ADDENDUM IS ISSUED TO PROVIDE THE ATTACHED TECHNICAL QUESTIONS INADVERTANTLY OMITTED FROM ADDENDUM NO. 1.						
THE BID OPENING DATE AND TIME HAVE CHANGED. BID OPENING IS CHANGED TO 03/25/2010 AT 1:30 PM.						
0001	1	PM		395-30-99-001		
PRE-ENGINEERED BUS PASSENGER SHELTERS						
***** THIS IS THE END OF RFQ PTR10035 ***** TOTAL:						

SEE REVERSE SIDE FOR TERMS AND CONDITIONS

SIGNATURE: *Seaf* TELEPHONE: 800-893-3665 DATE: 3/15/10
 TITLE: Sales FEIN: 38-3156752 ADDRESS CHANGES TO BE NOTED ABOVE

WHEN RESPONDING TO RFQ, INSERT NAME AND ADDRESS IN SPACE ABOVE LABELED 'VENDOR'

TECHNICAL QUESTIONS-RFQ# PTR10035

Question #1-Paragraph 2.2.1 and 2.2.2 reference a specific manufacturer's part number. The specs of those particular shelters are really only know to those two manufacturers. Can you provide more specific information about the specifications of the two shelters noted?

Answer-Please note the specs in 2.1, 2.3, 2.4-2.6.

Question #2 - It appears from their website that the Daytech Victorian shelter may have some ceramic decoration in the glass, but paragraph 2.3 states that the wall panels be bronze tinted structured polycarbonate.

Answer-This is not a requirement.

Question #3 -Due to the potentially large number of shelters, can a minimum order of the 12 variations be established?

Answer-Denied.



State of West Virginia
 Department of Administration
 Purchasing Division
 2019 Washington Street East
 Post Office Box 50130
 Charleston, WV 25305-0130

WV PURCHASING DIVN.

Fax 304-558-3970

Mar 24 2010 01:02pm

P001/005

**Request for
 Quotation**

REQ NUMBER
 PTR10035

PAGE
 1

ADDRESS CORRESPONDENCE TO ATTENTION OF
 FRANK WHITTAKER
 304-558-2316

*A19154957 800-893-3665
 BRASCO INTERNATIONAL INC
 1000 MT ELLIOTT
 DETROIT MI 48207-3426

DIVISION OF PUBLIC TRANSIT
 BUILDING 5, ROOM 906
 1900 KANAWHA BOULEVARD, EAST
 CHARLESTON, WV
 25305-0432 304-558-0428

DATE PRINTED	TERMS OF SALE	SHIP VIA	FOB	FREIGHT TERMS
03/24/2010	Net 30	Best Way	Destination	Included

BID OPENING DATE: 04/01/2010 BID OPENING TIME 01:30PM

LINE	QUANTITY	UQP	CAT NO	ITEM NUMBER	UNIT PRICE	AMOUNT
***** ADDENDUM NO. 3 *****						
THIS ADDENDUM IS ISSUED TO PROVIDE THE ATTACHD BID FORMS 1 THROUGH 4 AND EXTEND THE BID OPENING DATE AND TIME.						
BID OPENING DATE CHANGED TO: 04/01/10 AT 1:30 PM						
0001	1	PM		395-30-99-001		
PRE-ENGINEERED BUS PASSENGER SHELTERS						
***** THIS IS THE END OF RFQ PTR10035 ***** TOTAL: _____						

SEE REVERSE SIDE FOR TERMS AND CONDITIONS

SIGNATURE: *[Signature]* TELEPHONE: 800-893-3665 DATE: 3/24/10

TITLE: Sales FEIN: 38-3156752 ADDRESS CHANGES TO BE NOTED ABOVE

WHEN RESPONDING TO RFQ, INSERT NAME AND ADDRESS IN SPACE ABOVE LABELED 'VENDOR'

Added

BID FORM #1

BUY AMERICA CERTIFICATION

Bidder or offerer to complete correct certification.

Certificate of Compliance with Section 165(a)

The bidder or offerer hereby certifies that it will comply with the requirements of section 165(a) of the Surface Transportation Act of 1982, as amended, and the applicable regulations in 49 CFR part 661.

3/24/10
 Date _____
Sean Loewe
 Authorized Signature _____
Brasco International, Inc.
 Company Name _____
Sean Loewe
 Name _____
Sales
 Title _____

Certificate for Non-Compliance with Section 165(a)

The bidder or offerer hereby certifies that it cannot comply with the requirements of section 165(a) of the Surface Transportation Assistance Act of 1982, as amended, but it may qualify for an exception to the requirement pursuant to section 165(b)(2) or (b)(4) of the Surface Transportation Act of 1982, as amended, and the regulations in 49 CFR 661.7.

 Date _____

 Authorized Signature _____

 Company Name _____

 Name _____

 Title _____

BID FORM #2

VENDOR'S CERTIFICATION OF UNDERSTANDING AND ACCEPTANCE

The Contractor hereby certifies that all Technical Specifications and Contract Terms and Conditions have been carefully reviewed, are fully understood and shall be adhered to in performance and completion of any contract resulting from this bid.

3/24/10
 Date
Seafe
 Authorized Signature
Sales
 Title
Brasco International, Inc.
 Company Name

SPECIFICATION COMPLIANCE

NOTE: Please check if what is offered is in exact compliance with specifications. **Any discrepancies must** be listed as an attachment to the bid proposal. Exact dimensions and/or descriptions must be provided as a part of the Contractor's bid proposal when submitted.

- Bid proposal submitted meets and/or exceeds all specification requirements.
- Bid proposal submitted contains deviations from specification requirements. Detailed descriptions of these have been provided with this bid proposal.

BID FORM #3**CERTIFICATION OF PRIMARY PARTICIPANT REGARDING
DEBARMENT, SUSPENSION, AND OTHER RESPONSIBILITY MATTERS**

The Primary Participant (applicant for an ETA grant or cooperative agreement, or potential contractor for a major third party contract),

Brasco International, Inc. (COMPANY NAME)
certifies to the best of its knowledge and belief, that it and its principals:

1. Are not presently debarred, suspended, proposed for debarment, declared ineligible, or voluntarily excluded from covered transactions by any Federal department or agency;
2. Have not within a three-year period preceding this proposal been convicted of or had a civil judgment rendered against them for commission of fraud or a criminal offense in connection with obtaining, attempting to obtain, or performing a public (Federal, State or local) transaction or contract under a public transaction; violation of Federal or State antitrust statutes or commission of embezzlement, theft, forgery, bribery, falsification or destruction of records, making false statements, or receiving stolen property;
3. Are not presently indicted for or otherwise criminally or civilly charged by a governmental entity (Federal, State or local) with commission of any of the offenses enumerated in paragraph (2) of this certification; and
4. Have not within a three-year period preceding this application/proposal had one or more public transactions (Federal, State or local) terminated for cause or default.

(If the primary participant (applicant for an ETA grant, or cooperative agreement, or potential third party contractor) is unable to certify to any of the statements in this certification, the participant shall attach an explanation to this certification.)

THE PRIMARY PARTICIPANT (APPLICANT FOR AN FTA GRANT OR COOPERATIVE AGREEMENT, OR POTENTIAL CONTRACTOR FOR A MAJOR THIRD PARTY CONTRACT),

Brasco International, Inc. CERTIFIES OR AFFIRMS THE TRUTHFULNESS AND ACCURACY OF THE CONTENTS OF THE STATEMENTS SUBMITTED ON OR WITH THIS CERTIFICATION AND UNDERSTANDS THAT THE PROVISIONS OF 31 U.S.C. SECTIONS 3801 ET SEQ. ARE APPLICABLE THERETO.

Seafon Sales
Signature and Title of Authorized Official

Added

BID FORM #4

CERTIFICATION OF RESTRICTIONS ON LOBBYING

The undersigned (Vendor, Contractor) certifies, to the best of his or her knowledge and belief, that:

1. No Federal appropriated funds have been paid or will be paid, by or on behalf of the undersigned, to any person for influencing or attempting to influence an officer or employee of an agency, a Member of Congress, an officer or employee of Congress, or an employee of a Member of Congress in connection with the awarding of any Federal contract, the making of any Federal grant, the making of any Federal loan, the entering into of any cooperative agreement, and the extension, continuation, renewal, amendment, or modification of any Federal contract, grant, loan, or cooperative agreement.
2. If any funds other than Federal appropriated funds have been paid or will be paid to any person for making lobbying contacts to an officer or employee of any agency, a Member of Congress, an officer or employee of Congress, or an employee of a Member of Congress in connection with this Federal contract, grant, loan, or cooperative agreement, the undersigned shall complete and submit Standard Form-LLL, "Disclosure Form to Report Lobbying," in accordance with its instructions. [as amended by "Government Wide Guidance for New Restrictions on Lobbying," 61 Fed. Reg. 1413 (1/19/96). Note: Language in paragraph (2) herein has been modified in accordance with Section 10 of the Lobbying Disclosure Act of 1995 (P.L. 104-65, to be codified at 2 U.S.C. 1601, et seq.)]
3. The undersigned shall require that the language of this certification be included in the award documents for all subawards at all tiers (including subcontracts, subgrants, and contracts under grants, loans, and cooperative agreements) and that all subrecipients shall certify and disclose accordingly.

This certification is a material representation of fact upon which reliance was placed when this transaction was made or entered into. Submission of this certification is a prerequisite for making or entering into this transaction imposed by 31 U.S.C. § 1352 (as amended by the Lobbying Disclosure Act of 1995). Any person who fails to file the required certification shall be subject to a civil penalty of not less than \$10,000 and not more than \$100,000 for each such failure. [Note: Pursuant to 31 U.S.C. § 1352(c)(1)-(2)(A), any person who makes a prohibited expenditure or fails to file or amend a required certification or disclosure form shall be subject to a civil penalty of not less than \$10,000 and not more than \$100,000 for each such expenditure or failure.]

The Vendor, Brasco International, Inc., certifies or affirms the truthfulness and accuracy of each statement of its certification and disclosure, if any. In addition, the Vendor understands and agrees that the provisions of 31 U.S.C. § 3801, et seq., apply to this certification and disclosure, if any.

3/24/10
Date

Authorized Signature
Sales
Title



State of West Virginia
 Department of Administration
 Purchasing Division
 2019 Washington Street East
 Post Office Box 50130
 Charleston, WV 25305-0130

**request for
 Quotation**

NO. 8382 P. 1/1

RFQ NUMBER
PTR10035

1

ADDRESS CORRESPONDENCE TO ATTENTION OF
**FRANK WHITTAKER
 304-558-2316**

*A19154957 800-893-3665
**BRASCO INTERNATIONAL INC
 1000 MT ELLIOTT
 DETROIT MI 48207-3426**

**DIVISION OF PUBLIC TRANSIT
 BUILDING 5, ROOM 906
 1900 KANAWHA BOULEVARD, EAST
 CHARLESTON, WV
 25305-0432 304-558-0428**

DATE PRINTED	TERMS OF SALE	SHIP VIA	P.C.B.	FREIGHT TERMS
03/25/2010	Net 30	Best Way	Destination	Included
BID OPENING DATE: 04/01/2010		BID OPENING TIME 01:30PM		

LINE	QUANTITY	UQP	CAT NO	ITEM NUMBER	UNIT PRICE	AMOUNT
***** ADDENDUM NO. 4 *****						
THIS ADDENDUM IS ISSUED TO SET THE DEADLINE FOR TECHNICAL QUESTIONS.						
DEADLINE FOR ALL TECHNICAL QUESTIONS IS 03/26/2010 AT 3:00 PM. TECHNICAL QUESTIONS WILL BE ADDRESSED BY ADDENDUM AFTER THE DEADLINE.						
0001	1	PM		395-30-99-001		
PRE-ENGINEERED BUS PASSENGER SHELTERS						
***** THIS IS THE END OF RFQ PTR10035 ***** TOTAL:						

SEE REVERSE SIDE FOR TERMS AND CONDITIONS

SIGNATURE *Sale* TELEPHONE 800-893-3665 DATE 3/25/10

TITLE *Saler* FEIN 38-3156752 ADDRESS CHANGES TO BE NOTED ABOVE

WHEN RESPONDING TO RFQ, INSERT NAME AND ADDRESS IN SPACE ABOVE LABELED 'VENDOR'

Added



State of West Virginia
 Department of Administration
 Purchasing Division
 2019 Washington Street East
 Post Office Box 50130
 Charleston, WV 25305-0130

**Request for
 Quotation**

RFQ NUMBER
PTR10035

PAGE
1

ADDRESS CORRESPONDENCE TO ATTENTION OF
**FRANK WHITTAKER
 304-558-2316**

RFQ COPY

TYPE NAME/ADDRESS HERE

RFQ COPY

DIVISION OF PUBLIC TRANSIT
 BUILDING 5, ROOM 906
 1900 KANAWHA BOULEVARD, EAST
 CHARLESTON, WV
 25305-0432 304-558-0428

DATE PRINTED 03/29/2010	TERMS OF SALE Net 30	SHIP VIA Best Way	FOB Destination	FREIGHT TERMS Included
BID OPENING DATE: 04/01/2010		BID OPENING TIME 01:30PM		

LINE	QUANTITY	UOP	CAT. NO.	ITEM NUMBER	UNIT PRICE	AMOUNT
***** ADDENDUM NO. 5 *****						
THIS ADDENDUM IS ISSUED TO PROVIDE THE ATTACHED TECHNICAL QUESTIONS AND ANSWERS.						
BID OPENING DATE AND TIME HAVE NOT CHANGED.						
0001	1	PM		395-30-99-001		
PRE-ENGINEERED BUS PASSENGER SHELTERS						
***** THIS IS THE END OF RFQ PTR10035 ***** TOTAL:						

SEE REVERSE SIDE FOR TERMS AND CONDITIONS

SIGNATURE *Seager* TELEPHONE **800-893-3665** DATE **3/29/10**

TITLE *Sales* FEIN **38-3156752** ADDRESS CHANGES TO BE NOTED ABOVE

WHEN RESPONDING TO RFQ, INSERT NAME AND ADDRESS IN SPACE ABOVE LABELED 'VENDOR'

Added

PTR10035 Technical Questions and Answers

1) Section 2.3 states (and addendum 2, question 2 seems to reiterate) that the wall glazing is to be "translucent polycarbonate structured sheet." Polycarbonate *structured* sheet is a multi-wall / fluted / ribbed material that is not transparent, and is translucent to the point of having a shower door quality, so that images are very distorted. Is this your intent, or were you wanting a transparent solid polycarbonate (with a bronze tint)?

Answer: Bronze tint will be approved.

2) For the roof metal, will you accept a galvanized / "galvalume-coated" steel roof panel (barrel and hip shapes), with a 20-year warranty 3-coat Kynar 500 paint finish, assuming it matches the color of the rest of the shelter?

Answer: This must meet specs as stated. Denied.

3) Since each transit system is choosing colors, if the above roof metal option is approved, can the systems choose a roof color that may or may not be the same as the rest of the shelter, but complimentary, from a standard chart?

Answer: Denied.

4) Can you give an idea or a range of about how many shelters of a particular type / color each transit system will be ordering?

Answer: WVDPT can't guarantee the number of any orders. Please review RFQ.



State of West Virginia
 Department of Administration
 Purchasing Division
 2019 Washington Street East
 Post Office Box 50130
 Charleston, WV 25305-0130

Request for Quotation

RFQ NUMBER
 PTR10035

PAGE
 1

ADDRESS CORRESPONDENCE TO ATTENTION OF
 FRANK WHITTAKER
 804-558-2316

VENDOR ROOM

*A19154957 800-893-3665
 BRASCO INTERNATIONAL INC
 1000 MT ELLIOTT

DETROIT MI 4820

RECEIVED
 FEB 22 2010

SHIP TO

DIVISION OF PUBLIC TRANSIT
 BUILDING 5, ROOM 906
 1900 KANAWHA BOULEVARD, EAST
 CHARLESTON, WV
 25305-0432 304-558-0428

DATE PRINTED	TERMS OF SALE	SHIP VIA	F.O.B.	FREIGHT TERMS
02/18/2010	net 30	Best Way	Destination	Included

BID OPENING DATE: 03/16/2010 BID OPENING TIME 01:30PM

LINE	QUANTITY	UOP	CAT. NO.	ITEM NUMBER	UNIT PRICE	AMOUNT
0001	1	PM		395-30-99-001		
<p>PRE-ENGINEERED BUS PASSENGER SHELTERS</p> <p>THE WEST VIRGINIA PURCHASING DIVISION, FOR THE AGENCY, THE WEST VIRGINIA DIVISION OF PUBLIC TRANSIT IS REQUESTING QUOTATIONS FOR PRE-ENGINEERED BUS PASSENGER SHELTERS, SOLAR LIGHTING SYSTEM FOR BUS SHELTERS, AND SOLAR POWERED TRANSIT STOPS PER THE ATTACHED SPECIFICATIONS.</p> <p>EXHIBIT 3</p> <p>LIFE OF CONTRACT: THIS CONTRACT BECOMES EFFECTIVE ON AND EXTENDS FOR A PERIOD OF ONE (1) YEAR OR UNTIL SUCH "REASONABLE TIME" THEREAFTER AS IS NECESSARY TO OBTAIN A NEW CONTRACT OR RENEW THE ORIGINAL CONTRACT. THE "REASONABLE TIME" PERIOD SHALL NOT EXCEED TWELVE (12) MONTHS. DURING THIS "REASONABLE TIME" THE VENDOR MAY TERMINATE THIS CONTRACT FOR ANY REASON UPON GIVING THE DIRECTOR OF PURCHASING 30 DAYS WRITTEN NOTICE.</p> <p>UNLESS SPECIFIC PROVISIONS ARE STIPULATED ELSEWHERE IN THIS CONTRACT DOCUMENT, THE TERMS, CONDITIONS AND PRICING SET HEREIN ARE FIRM FOR THE LIFE OF THE CONTRACT.</p> <p>RENEWAL: THIS CONTRACT MAY BE RENEWED UPON THE MUTUAL WRITTEN CONSENT OF THE SPENDING UNIT AND VENDOR, SUBMITTED TO THE DIRECTOR OF PURCHASING THIRTY (30) DAYS PRIOR TO THE EXPIRATION DATE. SUCH RENEWAL SHALL BE IN ACCORDANCE WITH THE TERMS AND CONDITIONS OF THE</p>						

SEE REVERSE SIDE FOR TERMS AND CONDITIONS

SIGNATURE <i>Seaf</i>	TELEPHONE 800-893-3665	DATE 3/12/10
TITLE Sales	FEIN 38-3156752	ADDRESS CHANGES TO BE NOTED ABOVE

WHEN RESPONDING TO RFQ, INSERT NAME AND ADDRESS IN SPACE ABOVE LABELED 'VENDOR'



State of West Virginia
 Department of Administration
 Purchasing Division
 2019 Washington Street East
 Post Office Box 50130
 Charleston, WV 25305-0130

Request for Quotation

RFQ NUMBER
PTR10035

PAGE
2

ADDRESS CORRESPONDENCE TO ATTENTION OF
FRANK WHITTAKER 304-558-2316

SUZZOR

*A19154957 800-893-3665
 BRASCO INTERNATIONAL INC
 1000 MT ELLIOTT
 DETROIT MI 48207-3426

SHIP TO

DIVISION OF PUBLIC TRANSIT
 BUILDING 5, ROOM 906
 1900 KANAWHA BOULEVARD, EAST
 CHARLESTON, WV
 25305-0432 304-558-0428

DATE PRINTED	TERMS OF SALE	SHIP VIA	F.O.B	FREIGHT TERMS
02/18/2010	Net 30	Best Way	Destination	Included

BID OPENING DATE:	03/16/2010	BID OPENING TIME	01:30PM			
LINE	QUANTITY	UOP	CAT NO.	ITEM NUMBER	UNIT PRICE	AMOUNT

ORIGINAL CONTRACT AND SHALL BE LIMITED TO TWO (2) ONE (1) YEAR PERIODS.

CANCELLATION: THE DIRECTOR OF PURCHASING RESERVES THE RIGHT TO CANCEL THIS CONTRACT IMMEDIATELY UPON WRITTEN NOTICE TO THE VENDOR IF THE COMMODITIES AND/OR SERVICE SUPPLIED ARE OF AN INFERIOR QUALITY OR DO NOT CONFORM TO THE SPECIFICATIONS OF THE BID AND CONTRACT HEREIN.

OPEN MARKET CLAUSE: THE DIRECTOR OF PURCHASING MAY AUTHORIZE A SPENDING UNIT TO PURCHASE ON THE OPEN MARKET, WITHOUT THE FILING OF A REQUISITION OR COST ESTIMATE, ITEMS SPECIFIED ON THIS CONTRACT FOR IMMEDIATE DELIVERY IN EMERGENCIES DUE TO UNFORESEEN CAUSES (INCLUDING BUT NOT LIMITED TO DELAYS IN TRANSPORTATION OR AN UNANTICIPATED INCREASE IN THE VOLUME OF WORK.)

QUANTITIES: QUANTITIES LISTED IN THE REQUISITION ARE APPROXIMATIONS ONLY, BASED ON ESTIMATES SUPPLIED BY THE STATE SPENDING UNIT. IT IS UNDERSTOOD AND AGREED THAT THE CONTRACT SHALL COVER THE QUANTITIES ACTUALLY ORDERED FOR DELIVERY DURING THE TERM OF THE CONTRACT, WHETHER MORE OR LESS THAN THE QUANTITIES SHOWN.

ORDERING PROCEDURE: SPENDING UNIT(S) SHALL ISSUE A WRITTEN STATE CONTRACT ORDER (FORM NUMBER WV-39) TO THE VENDOR FOR COMMODITIES COVERED BY THIS CONTRACT. THE ORIGINAL COPY OF THE WV-39 SHALL BE MAILED TO THE VENDOR AS AUTHORIZATION FOR SHIPMENT, A SECOND COPY MAILED TO THE PURCHASING DIVISION, AND A THIRD COPY RETAINED BY THE SPENDING UNIT.

BANKRUPTCY: IN THE EVENT THE VENDOR/CONTRACTOR FILES FOR BANKRUPTCY PROTECTION, THE STATE MAY DEEM THE CONTRACT NULL AND VOID AND TERMINATE SUCH CONTRACT

SEE REVERSE SIDE FOR TERMS AND CONDITIONS

SIGNATURE	TELEPHONE	DATE
<i>[Signature]</i>	800-893-3665	3/12/10
TITLE	FERN	ADDRESS CHANGES TO BE NOTED ABOVE
Sales	38-315675Z	

WHEN RESPONDING TO RFQ, INSERT NAME AND ADDRESS IN SPACE ABOVE LABELED 'VENDOR'



State of West Virginia
 Department of Administration
 Purchasing Division
 2019 Washington Street East
 Post Office Box 50130
 Charleston, WV 25305-0130

Request for Quotation

RFQ NUMBER
PTR10035

PAGE
3

ADDRESS CORRESPONDENCE TO ATTENTION OF:
FRANK WHITTAKER 304-558-2316

VENDOR

*A19154957 800-893-3665
 BRASCO INTERNATIONAL INC
 1000 MT ELLIOTT
 DETROIT MI 48207-3426

SHIP TO

DIVISION OF PUBLIC TRANSIT
 BUILDING 5, ROOM 906
 1900 KANAWHA BOULEVARD, EAST
 CHARLESTON, WV
 25305-0432 304-558-0428

DATE PRINTED	TERMS OF SALE	SHIP VIA	F.O.B.	FREIGHT TERMS
02/18/2010	Net 30	Best Way	Destination	Included

BID OPENING DATE: 03/16/2010 BID OPENING TIME 01:30PM

LINE	QUANTITY	UOP	CAT. NO.	ITEM NUMBER	UNIT PRICE	AMOUNT
WITHOUT FURTHER ORDER. THE TERMS AND CONDITIONS CONTAINED IN THIS CONTRACT SHALL SUPERSEDE ANY AND ALL SUBSEQUENT TERMS AND CONDITIONS WHICH MAY APPEAR ON ANY ATTACHED PRINTED DOCUMENTS SUCH AS PRICE LISTS, ORDER FORMS, SALES AGREEMENTS OR MAINTENANCE AGREEMENTS, INCLUDING ANY ELECTRONIC MEDIUM SUCH AS CD-ROM. REV. 05/26/2009 NOTICE A SIGNED BID MUST BE SUBMITTED TO: DEPARTMENT OF ADMINISTRATION PURCHASING DIVISION BUILDING 15 2019 WASHINGTON STREET, EAST CHARLESTON, WV 25305-0130 THE BID SHOULD CONTAIN THIS INFORMATION ON THE FACE OF THE ENVELOPE OR THE BID MAY NOT BE CONSIDERED: SEALED BID BUYER: 44 RFQ. NO.: PTR10035 BID OPENING DATE: 03/16/2010 BID OPENING TIME: 1:30 PM						

SEE REVERSE SIDE FOR TERMS AND CONDITIONS

SIGNATURE <i>Soaf</i>	TELEPHONE 800-893-3665	DATE 3/12/10
TITLE Sales	FEIN 38-315675Z	ADDRESS CHANGES TO BE NOTED ABOVE

WHEN RESPONDING TO RFQ, INSERT NAME AND ADDRESS IN SPACE ABOVE LABELED 'VENDOR'



State of West Virginia
 Department of Administration
 Purchasing Division
 2019 Washington Street East
 Post Office Box 50130
 Charleston, WV 25305-0130

Request for Quotation

RFQ NUMBER
PTR10035

PAGE
4

ADDRESS CORRESPONDENCE TO ATTENTION OF
FRANK WHITTAKER
804-558-2316

VENDOR

*A19154957 800-893-3665
 BRASCO INTERNATIONAL INC
 1000 MT ELLIOTT
 DETROIT MI 48207-3426

SHIP TO

DIVISION OF PUBLIC TRANSIT
 BUILDING 5, ROOM 906
 1900 KANAWHA BOULEVARD, EAST
 CHARLESTON, WV
 25305-0432 304-558-0428

DATE PRINTED	TERMS OF SALE	SHIP VIA	F.O.B	FREIGHT TERMS
02/18/2010	Net 30	Best Way	Destination	Included
BID OPENING DATE: 03/16/2010		BID OPENING TIME 01:30PM		

LINE	QUANTITY	UOP	CAT. NO.	ITEM NUMBER	UNIT PRICE	AMOUNT
PLEASE PROVIDE A FAX NUMBER IN CASE IT IS NECESSARY TO CONTACT YOU REGARDING YOUR BID: ----- (313) 393-0499 ----- CONTACT PERSON (PLEASE PRINT CLEARLY): ----- Sean Loewe -----						
***** THIS IS THE END OF RFQ PTR10035 ***** TOTAL:						-

SEE REVERSE SIDE FOR TERMS AND CONDITIONS

SIGNATURE: *Sean Loewe* TELEPHONE: 800-893-3665 DATE: 3/12/10

TITLE: Sales FEIN: 38-3156752

ADDRESS CHANGES TO BE NOTED ABOVE

WHEN RESPONDING TO RFQ, INSERT NAME AND ADDRESS IN SPACE ABOVE LABELED 'VENDOR'

Bus Passenger Shelters
Specifications
PTR10035

1.0 GENERAL

1.1 SCOPE

The following specifications cover the design, fabrication and installation of pre-engineered bus passenger shelters. The bus passenger shelters shall protect against the environmental elements, and is intended to serve as a passenger waiting shelter, or in general as a protection from inclement weather.

The vendor shall comply with all applicable federal and state regulations in the manufacturing for the passenger bus shelters.

All units or parts not specified shall be manufacturer's best quality and shall conform in material, design or workmanship to the best practice known. All parts shall be new. No parts will be accepted if used, reconditioned or obsolete.

The price for each passenger bus shelter is suggest to be submitted in whole dollars only and freight and shipping charges to various locations in West Virginia shall be included. The award of the bid may be made to multiple vendors.

1.2 STANDARDS

Shelter framework, wall and roof panels, equipment and related hardware shall be furnished by a manufacturer regularly engaged in the manufacturing of such products. All passenger bus shelter construction shall conform to construction standards of ASCE. All shelters shall be designed to withstand at minimum dead loads of 40 pfs and wind load of over 80 mph.

The passenger bus shelters must meet all Federal specification requirements and other requirements listed below:

1. Federal Specifications (Fed. Spec.):
 - a) QQ-A-200/9C (1)....Extruded aluminum members 6063-T5
 - b) HH-I-521B....Insulation board, Thermal, Semi-Rigid Polyurethane.
 - c) TT-S-001657....Sealants, Type 1.
2. American Society for Testing Materials (ASTM):
 - a) C-920-79....Elastomeric Joint Sealants Type S, Class 12, Grade NS
 - b) C-518....Insulation Board, Semi-Rigid Polyurethane.
 - c) E-84....Standards method of test for surface burning characteristics of building materials.
3. American National Standards Institute (ANSI): ANSI A58.1....Gravity and Lateral Loads Design.
4. Uniform Federal Accessibility Standards: FED-STD-795, 4/1/88.....4.13 Door Accessibility.

5. The Aluminum Association (AA): Designation System for Aluminum Finishes (March 1973).
6. International Conference of Building Officials, Uniform Building Code.
7. Public Law 101-336: Americans with Disabilities Act of 1990 (ADA).
8. Public Law 102-585: Veterans Health Care Act of 1992, Sec. 526

1.3 SUBMITTALS

The following drawings and documentation shall be furnished:

1. Shop drawings shall show wall and roof panels; details of materials, fabrication and assembly; framing profiles; fastener types and locations, flashing, and seal details if applicable.
2. Erection drawings: Provide instructions and drawings, and develop erection procedures to enable field installation or repair of shelter. The delivery of each shelter shall be shipped in a protected form to ensure no damage upon delivery.
3. Manufacturer's literature and data, provide manufacturer's information for wall and roof panels, and all accessories and equipment furnished.
4. A detail set of pad specifications for each size of passenger bus shelter must be submitted with each shelter and a sample copy with bid.
5. The bidder must submit warranty, photo and literature information for each type of bus shelter that will be bid.
6. The bidder shall submit a color sample chart for each required color selection with bid.
7. The bidder shall submit a certification that all materials comply with the specification and are suitable for the intended application.

2.0 PRODUCT

2.1 STRUCTURAL FRAMING

1. The shelter framework (columns, sills, and headers) shall be fabricated using 6063-T5 extruded aluminum members (Fed. Spec. QQ-A-200/9C(1)).
2. Extrusion shapes shall be engineered to provide a framework of adequate structural integrity to satisfy the uniform building code (UBC), and to meet the requirements for snow, wind, and seismic loading for the location(s) being considered.
3. Framing members shall be at a minimum of 2.5" x 2.5" x 1/8" thick square extruded aluminum tubes. Mullions shall be 1.5" x 2.5" x 1/8" thick extruded aluminum tubes. Larger framing members to be used when required.
4. The framework shall be assembled with only stainless steel and aluminum fasteners to prevent rusting or electrolytic interaction with framing members.
5. Shelter framing components and the method of fastening them to the supporting foundations shall be capable of withstanding lateral loads per ANSI A58.1, the UBC, or applicable local building codes, whichever is more stringent.
6. Method of mounting shelter to concrete pad shall allow adjustment to varying sidewalk or mounting conditions. The base of the shelter columns shall be designed to accept both internal and external base flanges. If external base flanges are used, they shall have same anodized or duranodic finish as bus shelter. Painted flanges will not be accepted.
7. Bus Shelter posts shall contain internal drainage weep holes to prevent condensation build-up.
8. The entire shelter must be the same color on all metal components.

2.2 ROOF

2.2.1 STANDARD PASSENGER BUS SHELTER

The standard passenger bus shelter roof specification shall be aluminum roof panels in the barrel vault shape. Color shall be the same as the rest of the bus shelter which will be the choice of each transit system. Tolar Model 13NALD –PM, Duo-Gard, Brasco, Columbia Equipment Company or Equal.

The roof shall be enclosed both top and bottom by continuous, compressed gaskets of expanded EPT rubber or neoprene SCE41, with adhesive backing and shall be leak and condensation proof. All roof seams and joints between dome and aluminum shall be continuously sealed with premium construction grade silicone. Roof shall be held in place by stainless steel bolts. NO snap in members will be permitted. The roof can be wider than the side panels. The side panels are width requirements.

It is recommended that the vendor supply a color chart with bid. No white dome will be accepted.

2.2.2 VICTORIAN STYLE PASSENGER BUS SHELTER

The Victorian style passenger bus shelter roof specification shall be aluminum roof panels in a hip roof shape. Color shall be the same as the rest of the bus shelter which will be the choice of each transit system. The roof can be wider than the side panels. The side panels are width requirements. Daytech AHO05x10N VIC, Duo-Gard, Brasco, Columbia Equipment, Tolar or Equal.

The roof shall be enclosed both top and bottom by continuous, compressed gaskets of expanded EPT rubber or neoprene SCE41, with adhesive backing and shall be leak and condensation proof. All roof seams and joints between dome and aluminum shall be continuously sealed with premium construction grade silicone. Roof shall be held in place by stainless steel bolts. NO snap in members will be permitted.

It is recommended that the vendor supply a color chart with bid.

2.3 WINDOWS AND WALL PANELS

Window and roof panels shall a minimum of ¼" thick and secured to the framing structure with special extrusions to provide a safe weather-protective enclosure. Window color shall be bronze tint or as close to the color of the shelter as possible. Window material shall be translucent polycarbonate structured sheet and shall be sealed as to provide a water-proof barrier in compliance with all state and federal specifications.

2.4 FINISH

The finish of extruded aluminum framework shall be completed in accordance with the Aluminum Association and the color shall be chosen by the transit system. **It is recommended that the vendor supply a color chart with bid.**

2.5 ERECTION OF SHELTERS

The manufacturer shall provide a complete set of erection instructions with complete diagrams. Erection shall be performed by the transit systems.

2.6 PROTECTION AND CLEANING

The vendor shall ensure that the shelter panels and components are protected from damage during shipping and erection with proper materials supplied during shipping.

3.0 OPTIONS

3.1 OPTION 1: PERFORATED STEEL SIDE PANELS

This option will take place of standard side window and wall panels. The vendor shall supply installation procedures, warranty, literature and photos of material with bid. This option shall meet all specification requirements in Section 2.3. **It is recommended that the vendor supply a color chart with bid.**

3.2 OPTION 2: ALUMINUM SIDE PANELS

This option will take place of standard side window and wall panels. The vendor shall supply installation procedures, warranty, literature and photos of material with bid. This option shall meet all specification requirements in Section 2.3. **It is recommended that the vendor supply a color chart with bid.**

3.3 OPTION 3: SHELTER BENCH WITH ANTI-VAGRANT BARS

One 3' Perforated metal bench with no back and two anti-vagrant bars shall be supplied. It is recommended that the vendor submit installation instructions, complete diagrams, warranty, and literature with photos with bid. Tolar Manufacturing benches or Equal.

3.4 OPTION 4: SOLAR LIGHTING SYSTEM

A bus shelter LED lighting system providing ultra safe, low voltage lighting to illuminate shelters for passengers as they wait. No trenching, wiring and no connection to any power source is required. The system has be design to have vandal resistant hardware, 5-day battery reserve, plug in component and maintenance free gel batteries and at least a 2 -year warranty. **It is recommended that the vendor supply warranty information, specifications, literature, installation requirements and complete installation diagrams with bid.** SOL Model # TSSL or Equal.

3.5 OPTION 5: SOLAR POWERED TRANSIT STOP

Carmanah's i-STOP(r) Solar-Powered Transit Stop or Equal. **It is recommended that the vendor supply literature, warranty, installation requirements, complete installation diagrams and description with bid.**

PRICE SHEET
For
PTR10035

BUS SHELTER SIZES

1. STANDARD SHELTERS

	Estimated number of units	Extended Price
A: Size 3 x 9	100	\$ 192,500
B: Size 3 x 12	100	\$ 229,500
C: Size 5 x 7	100	\$ 213,500
D: Size 5 x 9	100	\$ 231,500
E: Size 5 x 10	100	\$ 257,500
F: Size 5 x 12	100	\$ 275,000

2. VICTORIAN STYLE SHELTERS

A: Size 3 x 9	100	\$ 197,500
B: Size 3 x 12	100	\$ 236,500
C: Size 5 x 7	100	\$ 218,500
D: Size 5 x 9	100	\$ 239,500
E: Size 5 x 10	100	\$ 266,500
F: Size 5 x 12	100	\$ 289,500

TOTAL FOR BID EVALUATION:

Note: Unit pricing above must be firm and will be used for when awarding the contract for these items.

\$ 2,847,500

OPTION SHEET
For
PTR10035

OPTIONS	Estimated number of units	Extended Price
OPTION 1: PERFORATED STEEL SIDE PANELS \$ <u>67</u>	100	\$ <u>6,700</u>
OPTION 2: ALUMINUM SIDE PANELS \$ <u>96</u>	100	\$ <u>9,600</u>
OPTION 3: SHELTER BENCH WITH ANTI-VAGRANT BARS \$ <u>175</u>	100	\$ <u>17,500</u>
OPTION 4: SOLAR LIGHTING SYSTEM \$ <u>950</u>	100	\$ <u>95,000</u>
OPTION 5: SOLAR POWERED TRANSIT STOP \$ <u>1,075</u>	100	\$ <u>107,500</u>
TOTAL FOR BID EVALUATION:		\$ <u>236,300</u> + 2,847,500 shelters <hr style="width: 100%;"/> 3,083,800 TOTAL

Note: Unit pricing above must be firm and will be used for when awarding the contract for these items.

Notification of Federal Participation

Federal funding for this project is being provided by the Federal Transit Administration through Section 5311 ARRA,CFDA 20509 for 100 % of the project cost and regular Section 5311, CFDA 25029 at 80% of the project cost.

No Federal Government Obligations to Third Parties

(1) The WV Division of Public Transit and Vendor acknowledge and agree that, notwithstanding any concurrence by the Federal Government in or approval of the solicitation or award of the underlying contract, absent the express written consent by the Federal Government, the Federal Government is not a party to this contract and shall not be subject to any obligations or liabilities to the WV Division of Public Transit, Vendor, or any other party (whether or not a party to that contract) pertaining to any matter resulting from the underlying contract.

(2) The Vendor agrees to include the above clause in each subcontract financed in whole or in part with Federal assistance provided by the Federal Transit Administration. It is further agreed that the clause shall not be modified, except to identify the subcontractor who will be subject to its provisions.

Program Fraud and False or Fraudulent Statements or Related Acts

(1) The Vendor acknowledges that the provisions of the Program Fraud Civil Remedies Act of 1986, as amended, 31 U.S.C. §§3801 *et seq.* and U.S. DOT regulations, "Program Fraud Civil Remedies," 49 C.F.R. Part 31, apply to its actions pertaining to this Project. Upon execution of the underlying contract, the Vendor certifies or affirms the truthfulness and accuracy of any statement it has made, it makes, it may make, or causes to be made, pertaining to the underlying contract or the Federal Transit Administration (FTA) assisted project for which this contract work is being performed. In addition to other penalties that may be applicable, the Vendor further acknowledges that if it makes, or causes to be made, a false, fictitious, or fraudulent claim, statement, submission, or certification, the Federal Government reserves the right to impose the penalties of the Program Fraud Civil Remedies Act of 1986 on the Vendor to the extent the Federal Government deems appropriate.

(2) The Vendor also acknowledges that if it makes, or causes to be made, a false, fictitious, or fraudulent claim, statement, submission, or certification to the Federal Government under a contract connected with a project that is financed in whole or in part with Federal assistance originally awarded by FTA under the authority of 49 U.S.C. § 5307, the Government reserves the right to impose the penalties of 18 U.S.C. § 1001 and 49 U.S.C. § 5307(n)(1) on the Vendor, to the extent the Federal Government deems appropriate.

(3) The Vendor agrees to include the above two clauses in each subcontract financed in whole or in part with Federal assistance provided by FTA. It is further agreed that the clauses shall not be modified, except to identify the subcontractor who will be subject to the provisions.

Exclusionary or Discriminatory Specifications

The Vendor agrees that it will comply with the requirements of 49 U.S.C. § 5325(h) by refraining from using any Federal assistance awarded by the WV Division of Public Transit to support procurements using exclusionary or discriminatory specifications.

Geographic Restrictions

The Vendor agrees to refrain from using state or local geographic preferences, except those expressly mandated or encouraged by Federal statute, and as permitted by FTA.

Audit and Inspection

The Vendor agrees to permit the WV Division of Public Transit, the Secretary of the United States Department of Transportation and the Comptroller General of the United States, or their authorized representatives, to inspect all Contract work, materials, payrolls, and other data and records with regard to the Contract. The Vendor also agrees to permit an audit of the books, records, and accounts of the Vendor and its subcontractors.

Disadvantaged Business Enterprise (DBE)

The Vendor shall not discriminate on the basis of race, color, national origin, or sex in the performance of this Contract. The requirements of 49 C.F.R. Part 26 and the WV Department of Transportation's (WVDOT) U.S. Department of Transportation (USDOT) approved Disadvantaged Business Enterprise (DBE) Program are incorporated in the Contract by reference. The Vendor agrees to take all necessary and reasonable steps under the requirements of 49 C.F.R. Part 26 and the USDOT approved Disadvantaged Business Enterprise (DBE) Program (where required) to ensure that eligible DBEs have the maximum feasible opportunity to participate in USDOT approved Contracts. Failure by the Vendor to carry out these requirements is a material breach of the Contract, which may result in the termination of this Contract or such other remedy as the WV Division of Public Transit deems appropriate.

Civil Rights

The following requirements apply to the underlying contract:

(1) Nondiscrimination. In accordance with Title VI of the Civil Rights Act of 1964, as amended, 42 U.S.C. §§ 2000d, Section 303 of the Age Discrimination Act of 1974, as amended, 42 U.S.C. § 6101 *et seq.*, Section 202 of the Americans With Disabilities Act of 1990, 42 U.S.C. § 12101 *et seq.*, and Federal transit law at 49 U.S.C. § 5332, the Vendor agrees that it will not discriminate against

any employee or applicant for employment because of race, color, creed, national origin, sex, age, or disability. In addition, the Vendor agrees to comply with applicable Federal implementing regulations and other implementing requirements FTA may issue.

(2) Equal Employment Opportunity. The following equal employment opportunity requirements apply to the underlying contract:

(a) Race, Color, Creed, National Origin, Sex. In accordance with Title VII of the Civil Rights Act of 1964, as amended, 42 U.S.C. § 2000e, and Federal transit laws at 49 U.S.C. § 5332, the Vendor agrees to comply with all applicable equal employment opportunity requirements of U.S. Department of Labor (U.S. DOL) regulations, "Office of Federal Contract Compliance Programs, Equal Employment Opportunity, Department of Labor," 41 C.F.R. Parts 60 et seq., (which implement Executive Order No. 11246, "Equal Employment Opportunity," as amended by Executive Order No. 11375, "Amending Executive Order 11246 Relating to Equal Employment Opportunity," 42 U.S.C. § 2000e note), and with any applicable Federal statutes, executive orders, regulations, and Federal policies that may in the future affect construction activities undertaken in the course of the Project. The Vendor agrees to take affirmative action to ensure that applicants are employed, and that employees are treated during employment, without regard to their race, color, creed, national origin, sex, disability or age. Such action shall include, but not be limited to, the following: employment, upgrading, demotion or transfer, recruitment or recruitment advertising, layoff or termination; rates of pay or other forms of compensation; and selection for training, including apprenticeship. In addition, the Vendor agrees to comply with any implementing requirements FTA may issue.

(b) Age. In accordance with the Age Discrimination Act of 1975, as amended, 42 U.S.C. §§ 6101 et seq. and implementing regulations, the Vendor agrees to refrain from discrimination against present and prospective employees for reason of age. In addition, the Vendor agrees to comply with any implementing requirements FTA may issue.

(c) Disabilities. In accordance with Section 102 of the Americans With Disabilities Act, as amended, 42 U.S.C. § 12112, the Vendor agrees that it will comply with the requirements of U.S. Equal Employment Opportunity Commission, "Regulations to Implement the Equal Employment Provisions of the Americans With Disabilities Act," 29 C.F.R. Part 1630, pertaining to employment of persons with disabilities. In addition, the Vendor agrees to comply with any implementing requirements FTA may issue.

(3) The Vendor also agrees to include these requirements in each subcontract financed in whole or in part with Federal assistance provided by FTA, modified only if necessary to identify the affected parties.

Energy Conservation

The Vendor agrees to comply with, and obtain the compliance of its subcontractors, with mandatory standards and policies relating to energy efficiency contained in applicable state energy conservation plans issued in compliance with the Energy Policy and Conservation Act, 42 U.S.C. §§ 6321 et seq.

Clean Air & Clean Water Requirements

(1) The Vendor agrees to comply with all applicable standards, orders or regulations issued pursuant to the Clean Air Act, as amended, 42 U.S.C. § 7414 and other applicable provisions of the Clean Air Act, as amended, 42 U.S.C. §§ 7401 et seq. and Section 508 of the Federal Water Pollution Control Act, as amended, 33 U.S.C. § 1368, and other provisions of the Federal Water Pollution Control Act, as amended, 33 U.S.C. §§ 1251 et seq. The Vendor agrees to report each violation to the WV Division of Public Transit and understands and agrees that the WV Division of Public Transit will, in turn, report each violation as required to assure notification to FTA and the appropriate EPA Regional Office.

(2) The Vendor also agrees to include these requirements in each subcontract exceeding \$100,000 financed in whole or in part with Federal assistance provided from FTA.

Application of Federal, State and Local Laws and Regulations

To achieve compliance with changing federal, state and local requirements, the Vendor shall note that federal, state and local requirements may change and the changed requirements will apply to this Contract as required.

Labor Provisions

The Vendor shall comply with Section 102 of the Contract Work Hours and Safety Standards Act (40 U.S.C. §§ 3701 et seq., esp. § 3702 & 3704) as supplemented by Department of Labor Regulations (29 CFR, § 5 & 29 CFR § 1926) as they involve the employment of mechanics and laborers.

Overtime Requirements. No Vendor or subcontractor for any part of the contract work which may require or involve the employment of laborers or mechanics shall require or permit any such laborer or mechanic in any workweek in which he or she is employed on such work to work in excess of forty hours in such workweek unless such laborer or mechanic receives compensation at a rate not less than one and one-half times the basic rate of pay for all hours worked in excess of forty hours in such workweek.

Violation; Liability for Unpaid Wages; Liquidated Damages. In the event of any violation of the clause set forth in paragraph (2) of this section, the Vendor and any subcontractor responsible therefore shall be liable for the unpaid wages. In addition, such Vendor and subcontractor shall be liable to the United States for liquidated damages. Such liquidated damages shall be computed with respect to each individual laborer or mechanic, including watchmen and guards, employed in violation of the clause set forth in paragraph (2) of this section, in the sum of \$10 for each calendar day on which such individual was required or permitted to work in excess of the standard workweek of forty hours without payment of the overtime wages required by the clause set forth in paragraph (2) of this section.

Withholding for Unpaid Wages and Liquidated Damages. The WV Division of Public Transit shall upon its own action or upon written request of an authorized representative of the Department of Labor withhold or cause to be withheld, from any moneys payable on account of work performed by the Vendor or subcontractor under any such contract or any other Federal contract with the same prime Vendor, or any other federally-assisted contract subject to the Contract Work Hours and Safety Standards Act, which is held by the same prime Vendor, such sums as may be determined to be necessary to satisfy any liabilities of such Vendor or subcontractor for unpaid wages and liquidated damages as provided in the clause set forth in paragraph (3) of this section.

Subcontracts. The Vendor or subcontractor shall insert in any subcontracts the clauses set forth in this section and also a clause requiring the subcontractors to include these clauses in any lower tier subcontracts. The prime Vendor shall be responsible for compliance by any subcontractor or lower tier subcontractor with the clauses set forth in this section.

Payrolls and Basic Records. Payrolls and basic records relating thereto shall be maintained by the Vendor during the course of the work and preserved for a period of three years thereafter for all laborers and mechanics working at the site of the work (or under the United States Housing Act of 1937, or under the Housing Act of 1949, in the construction or development of the project). Such records shall contain the name, address, and social security number of each such worker, his or her correct classification, hourly rates of wages paid (including rates of contributions or costs anticipated for bona fide fringe benefits or cash equivalents thereof of the types described in Section 1(b)(2)(B) of the Davis-Bacon Act), daily and weekly number of hours worked, deductions made and actual wages paid. Whenever the Secretary of Labor has found under 29 CFR .5(a)(1)(iv) that the wages of any laborer or mechanic include the amount of any costs reasonably anticipated in providing benefits under a plan or program described in Section 1(b)(2)(B) of the Davis-Bacon Act, the Vendor shall maintain records which show that the commitment to provide such benefits is enforceable, that the plan or program is financially responsible, and that the plan or program has been communicated in writing to the laborers or mechanics affected, and records which show the costs anticipated or the actual cost incurred in providing such benefits.

Vendors employing apprentices or trainees under approved programs shall maintain written evidence of the registration of apprenticeship programs and certification of trainee programs, the registration of the apprentices and trainees, and the ratios and wage rates prescribed in the applicable programs.

Termination

(a) Termination for Convenience

The WV Division of Public Transit may terminate this contract, in whole or in part, at any time by written notice to the Vendor when it is in the Government's best interest. The Vendor shall be paid its costs, including contract close-out costs, and profit on work performed up to the time of termination. The Vendor shall promptly submit its termination claim to the WV Division of Public Transit to be paid to the Vendor. If the Vendor has any property in its possession belonging to the WV Division of Public Transit, the Vendor will account for the same, and dispose of it in the manner the WV Division of Public Transit directs.

(b) Termination for Default (Breach or Cause)

If the Vendor does not deliver supplies in accordance with the contract delivery schedule, or, if the contract is for services, the Vendor fails to perform in the manner called for in the contract, or if the Vendor fails to comply with any other provisions of the contract, the WV Division of Public Transit may terminate this contract for default. Termination shall be effected by serving a notice of termination on the contractor setting forth the manner in which the Vendor is in default. The Vendor will only be paid the contract price for supplies delivered and accepted, or services performed in accordance with the manner of performance set forth in the contract.

If it is later determined by the WV Division of Public Transit that the Vendor had an excusable reason for not performing, such as a strike, fire, or flood, events which are not the fault of or are beyond the control of the Vendor, the WV Division of Public Transit, after setting up a new delivery of performance schedule, may allow the Vendor to continue work, or treat the termination as a termination for convenience.

(c) Opportunity to Cure

The WV Division of Public Transit in its sole discretion may, in the case of a termination for breach or default, allow the Vendor an appropriately short period of time in which to cure the defect. In such case, the notice of termination will state the time period in which cure is permitted and other appropriate conditions.

If Vendor fails to remedy to the WV Division of Public Transit's satisfaction the breach or default or any of the terms, covenants, or conditions of this Contract within ten (10) days after receipt by Vendor or written notice from the WV Division of Public Transit setting forth the nature of said breach or default, the WV Division of Public Transit shall have the right to terminate the Contract without any further obligation to Vendor. Any such termination for default shall not in any way operate to preclude the WV Division of Public Transit from also pursuing all available remedies against Vendor and its sureties for said breach or default.

(d) Waiver of Remedies for Any Breach

In the event that the WV Division of Public Transit elects to waive its remedies for any breach by Vendor of any covenant, term or condition of this Contract, such waiver by the WV Division of Public Transit shall not limit the WV Division of Public Transit's remedies for any succeeding breach of that or of any other term, covenant, or condition of this Contract.

Bankruptcy

Upon entering of a judgment of bankruptcy or insolvency by or against a Vendor, the WV Division of Public Transit may terminate this Contract for cause.

FTA Role in Bid Protests

Under the Federal Transit Administration's Circular 4220.1F, the Federal Transit Administration's (FTA's) appeals process for reviewing protests of a recipient's procurement decisions are:

1. Requirements for the Protester. The protester must:

- a. Qualify as an "Interested Party." Only an "interested party" qualifies for FTA review of its appeal. An "interested party" is a party that is an actual or prospective bidder or offeror whose direct economic interest would be affected by the award or failure to award the contract at issue.
 1. Subcontractors. A subcontractor does not qualify as an "interested party" because it does not have a direct economic interest in the results of the procurement.
 2. Consortia/Joint Ventures/Partnerships/Teams. An established consortium, joint venture, partnership, or team that is an actual bidder or offeror and is acting in its entirety, would qualify as an "interested party" because it has a direct economic interest in the results of the procurement. An individual member of a consortium, joint venture, partnership, or team, acting solely in its individual capacity, does not qualify as an "interested party" because it does not have a direct economic interest in the results of the procurement.
 3. Associations or Organizations. An association or organization that does not perform contracts does not qualify as an "interested party," because it does not have a direct economic interest in the results of the procurement.
- b. Exhaust Administrative Remedies. The protester must exhaust its administrative remedies by pursuing the WV Division of Public Transit's protest procedures to completion before appealing the WV Division of Public Transit's decision to FTA.
- c. Appeal Within Five Days. The protester must deliver its appeal to the FTA Regional Administrator, Region III, 1760 Market Street, Suite 500, Philadelphia, PA 19103-4124 within five (5) working days of the date when the protester has received actual or constructive notice of the WV Division of Public Transit's final decision. Likewise, the protester must provide its appeal to the same address within five (5) working days of the date when the protester has identified other grounds for appeal to FTA. For example, other grounds for appeal include the WV Division of Public Transit's failure to have or failure to comply with its protest procedures or failure to review the protest.

2. Extent of FTA Review. FTA limits its review of protests to:

- a. Failure of the Division of Public Transit to have or adhere to its written bid protest procedures, or failure of the Division of Public Transit to review a complaint or protest.
- b. Alleged violations on other grounds are under the jurisdiction of the appropriate State or local administrative authorities.
- c. Alleged violations of a specific Federal Law or regulation that provides an applicable complaint procedure shall be submitted and processed in accordance with that Federal Law or regulation. *See, e.g.,* Buy America Requirements, 49 C.F.R. Part 661 (Section 661.15); Participation by Minority Business Enterprise in Department of Transportation Programs, 49 C.F.R. Section 26.89.

FTA will exercise discretionary jurisdiction over those appeals involving issues important to FTA's overall public transportation program. FTA will refer violations of Federal law for which it does not have primary jurisdiction to the Federal authority having proper jurisdiction.

3. FTA Determinations to Decline Protest Reviews. FTA's determination to decline jurisdiction over a protest does not mean that FTA approves or agrees with the Division of Public Transit's decision or that FTA has determined the contract is eligible for Federal participation. FTA's determination means only that FTA does not consider the issues presented to be sufficiently important to FTA's overall program that FTA considers a review to be required.

Prohibited Interest

No employee, officer, board member, agent or their family members of the WV Division of Public Transit may participate in the selection, award, or administration of a Contract supported by Federal funds if a real or apparent conflict of interest is involved. Such a conflict could arise when any of the parties mentioned above have a financial or other interest in the Vendor selected for the Contract.

Preference for Recycled Products

The Vendor agrees to comply with all the requirements of Section 6002 of the Resource Conservation and Recovery Act, as amended (42 U.S.C. 6962), including but not limited to the regulatory provisions of 40 CFR Part 247, and Executive Order 12873, as they apply to the procurement of the items designated in Subpart B of 40 CFR Part 247.

Metric System

As required by U.S. DOT or FTA, the Vendor agrees to use the metric system of measurement in its Project activities, as may be required by Metric Conversion Act, as amended by the Omnibus Trade and Competitiveness Act, 15 U.S.C. §§ 205a et. seq.;

Executive Order No. 12770, "Metric Usage in Federal Government Programs," 15 U.S.C. § 205a note; and other regulations, guidelines, and policies issued by U.S. DOT or FTA.

Hold Harmless

The Vendor agrees to protect, defend, indemnify and hold the WV Division of Public Transit, its officers, employees and agents free and harmless from and against any and all losses, penalties, damages, settlements, costs, charges, professional fees or other expenses or liabilities of every kind and character arising out of or relating to any and all claims, liens, demands, obligations, actions, proceedings or causes of action of every kind and character in connection with or arising directly or indirectly out of this Contract and/or the performance hereof. Without limiting the generality of the foregoing, any and all such claims, etc. relating to personal injury, infringement of any patent, trademark, copyright (or application for any thereof) or of any other tangible or intangible personal or property right, or actual or alleged violation of any other tangible or intangible personal or property rights, or actual or alleged violation of any applicable statute, ordinance, administrative order, rule or regulation, or decrees of any court, shall be included in the indemnity hereunder. The Vendor further agrees to investigate, handle, respond to, provide defense for and defend any such claims, etc., at his/her sole expense and agrees to bear all other costs and expenses related thereto, even if such claim is groundless, false or fraudulent.

Licensing and Permits

The Vendor shall be appropriately licensed for the work required as a result of the Contract. The cost for any required licenses or permits shall be the responsibility of the Vendor. The Vendor is liable for any and all taxes due as a result of the Contract.

Compliance with Laws and Permits

The Vendor shall give all notices and comply with all existing and future federal, state and municipal laws, ordinances, rules, Regulations, and orders of any public authority bearing on the performance of the Contract, including, but not limited to, the laws referred to in these provisions of the Contract and the other Contract documents. If the Contract documents are at variance therewith in any respect, any necessary changes shall be incorporated by appropriate modification. Upon request, the Vendor shall furnish to the WV Division of Public Transit certificates of compliance with all such laws, orders, and regulations.

Prompt Payment

The prime Contractor agrees to pay each sub-contractor under this prime contract for satisfactory performance of its contract no later than 15 days from the receipt of each payment the prime Vendor receives from the Division of Public Transit. The Vendor agrees further to return retainage payments to each subcontractor within 15 days after the subcontractor's work is satisfactorily completed. Any delay or postponement of payment from the above referenced time frame may occur only for good cause following written approval of the Division of Public Transit. This clause applies to both DBE and non-DBE subcontractors.

Cargo Preference

The Vendor agrees:

To utilize privately owned United States--Flag commercial vessels to ship at least 50 percent of the gross tonnage (computed separately for dry bulk carriers, dry cargo liners, and tankers) involved, whenever shipping any equipment, material, or commodities pursuant to this contract, to the extent such vessels are available at fair and reasonable rates for United States--Flag commercial vessels;

To furnish within twenty (20) working days following the date of loading for shipments originating within the United States or within 30 working days following the date of leading for shipments originating outside the United States, a legible copy of a rated, "on board" commercial ocean bill of lading in English for each shipment of cargo described in the paragraph above to the Division of National Cargo, Office of Market Development, Maritime Administration, Washington, DC 20590 and to the Division of Public Transit (through the Vendor in the case of a subcontractor's bill of lading.)

To include these requirements in all subcontracts issued pursuant to this contract when the subcontract may involve the transport of equipment, material, or commodities by ocean vessel.

Federal Regulation Changes

Vendor shall at all times comply with all applicable FTA regulations, policies, procedures and directives, including without limitation those listed directly or by reference in the Master Agreement (Form FTA MA(15) dated October 1, 2008) between the WV Department of Transportation, Division of Public Transit and FTA, as they may be amended or promulgated from time to time during the term of this Contract. Vendor's failure to so comply shall constitute a material breach of this contract.

Severability

In the event any provision of the Contract is declared or determined to be unlawful, invalid or unconstitutional, such declaration shall not affect, in any manner, the legality of the remaining provisions of the Contract and each provision of the Contract will be and is deemed to be separate and severable from each other provision.

Debarment and Suspension

Vendor agrees to comply, and assures the compliance of any other participant at any tier of the project, with Executive Orders Nos. 12549 and 12689, "Debarment and Suspension," 31 U.S.S. § 6101 note, and U.S. DOT regulations; "Nonprocurement Suspension and Debarment," 2 CFR Part 1200, which adopts and supplements the provisions of U.S. Office of Management and Budget (U.S. OBM) "Guidelines to Agencies on Governmentwide Debarment and Suspension (Nonprocurement)," 2 CFR Part 180. The vendor agrees to, and assures that any other participant at any tier of the project will review the "Excluded Parties Listing System" at <http://epls.gov/> before entering into any other arrangement in connection with the project.

By signing and submitting its bid or proposal, the bidder certifies as follows:

The certification in this clause is a material representation of fact relied upon by the WV Division of Public Transit. If it is later determined that the bidder knowingly rendered an erroneous certification, in addition to remedies available to the WV Division of Public Transit, the Federal Government may pursue available remedies, including but not limited to suspension and/or debarment. The bidder agrees to comply with the requirements of 2 CFR Part 1200, while this offer is valid and throughout the period of any contract that may arise from this offer. The bidder further agrees to include a provision requiring such compliance in its lower tier covered transactions.

Accessibility

Vendor agrees that products provided shall be in accordance with the 42 U.S.C. Sections 12101 et seq. and DOT regulations, "Transportation Services for Individuals with Disabilities (ADA)," 49 CFR Part 37; and Joint ATBCB/DOT regulations, "American with Disabilities (ADA) Accessibility Specifications for Transportation Vehicles," 36 CFR Part 1192 and 49 CFR Part 38.

FTA Terms

The preceding provisions include, in part, certain Standard Terms and Conditions required by DOT, whether or not expressly set forth in the preceding contract provision. All contractual provisions required by DOT, as set forth in FTA Circular 4220.1F, are hereby incorporated by reference. Anything to the contrary herein notwithstanding, all FTA mandated terms shall be deemed to control in the event of a conflict with other provisions contained in this Contract. The Vendor shall not perform any act, fail to perform any act, or refuse to comply with any WV Division of Public Transit requests that would cause the WV Division of Public Transit to be in violation of the FTA terms and conditions.

03/11/2009



BRASCO

INTERNATIONAL

Point of Contact

1000 Mt. Elliott
Detroit, MI 48207
PHONE: (800) 893-3665
FAX: (313) 393-0499
WEB: www.brasco.com

Name: Sean Loewe
Title: Sales
Address: 1000 Mt. Elliott
Detroit, MI 48207
Office Phone: (800) 893-3665 x202
Cell Phone: (734) 564-6366
Fax: (313) 393-0499
Email: sloewe@brasco.com

If you have any questions regarding this information please do not hesitate to give me a call at (800) 893-3665

Sincerely,

Sean Loewe
Sales, Brasco International, Inc.



BRASCO

INTERNATIONAL

1000 Mt. Elliott
Detroit, MI 48207
PHONE: (800) 893-3665
FAX: (313) 393-0499
WEB: www.brasco.com

Statement of Warranty

Brasco International, Inc. shelters and benches are warranted to be free from defect in material and workmanship for a period of one (1) year from the date of delivery.

The powder coat painted finish is warranted for three (3) years against lifting, peeling, or flaking.

The Solar Lighting Components are warranted to be free from defect in material and workmanship for a period of five (5) years from the date of delivery.

Brasco International, Inc. shelters must be installed in accordance with the installation instructions received with your shelter.

If you have any questions regarding this warranty please call (800) 893-3665.



BRASCO

INTERNATIONAL

1000 Mt. Elliott
Detroit, MI 48207
PHONE: (800) 893-3665
FAX: (313) 393-0499
WEB: www.brasco.com

March 16, 2010

Frank Whittaker
Department of Administration
Purchasing Division
2019 Washington Street East
Charleston, WV 25305-0130

Re: RFQ #PTR10035 Pre-Engineered Bus Passenger Shelters – DBE Good Faith Efforts

As a long established manufacturer of passenger waiting shelters for transit agencies throughout the United States, we maintain a continuous search for DBE manufacturers of the small number of components that are utilized in the construction of our shelters.

Our shelters are manufactured from aluminum extrusions, glass, and various fasteners at our manufacturing facility in Detroit, MI. There are only a few large manufacturers of each of these items and we purchase directly from these companies. We fabricate all items here at our plant and we do not subcontract out any work to outside companies.

Brasco International is a woman owned business that is not certified as a WBE. Our company maintains a diverse workforce and is located in an urban setting in downtown Detroit, MI. We do not discriminate for any reason in the hiring, promotion of personnel, or the procurement of materials used in our plant.

If you have any questions regarding our DBE good faith efforts please call (800) 893-3665. Thank you and we look forward to working with you on this project.

Sincerely,

Sean Loewe
Sales, Brasco International, Inc.



BRASCO
INTERNATIONAL

1000 Mt. Elliott
Detroit, MI 48207
PHONE: (800) 893-3665
FAX: (313) 393-0499
WEB: www.brasco.com

Reference

Lee County Transit
6035 Landing View Road
Ft. Myers, FL 33907

Mitch Riley, Lee County Transit
Phone: (239) 823-0811

Hurricane Rated Advertising Shelters – Ongoing Contract

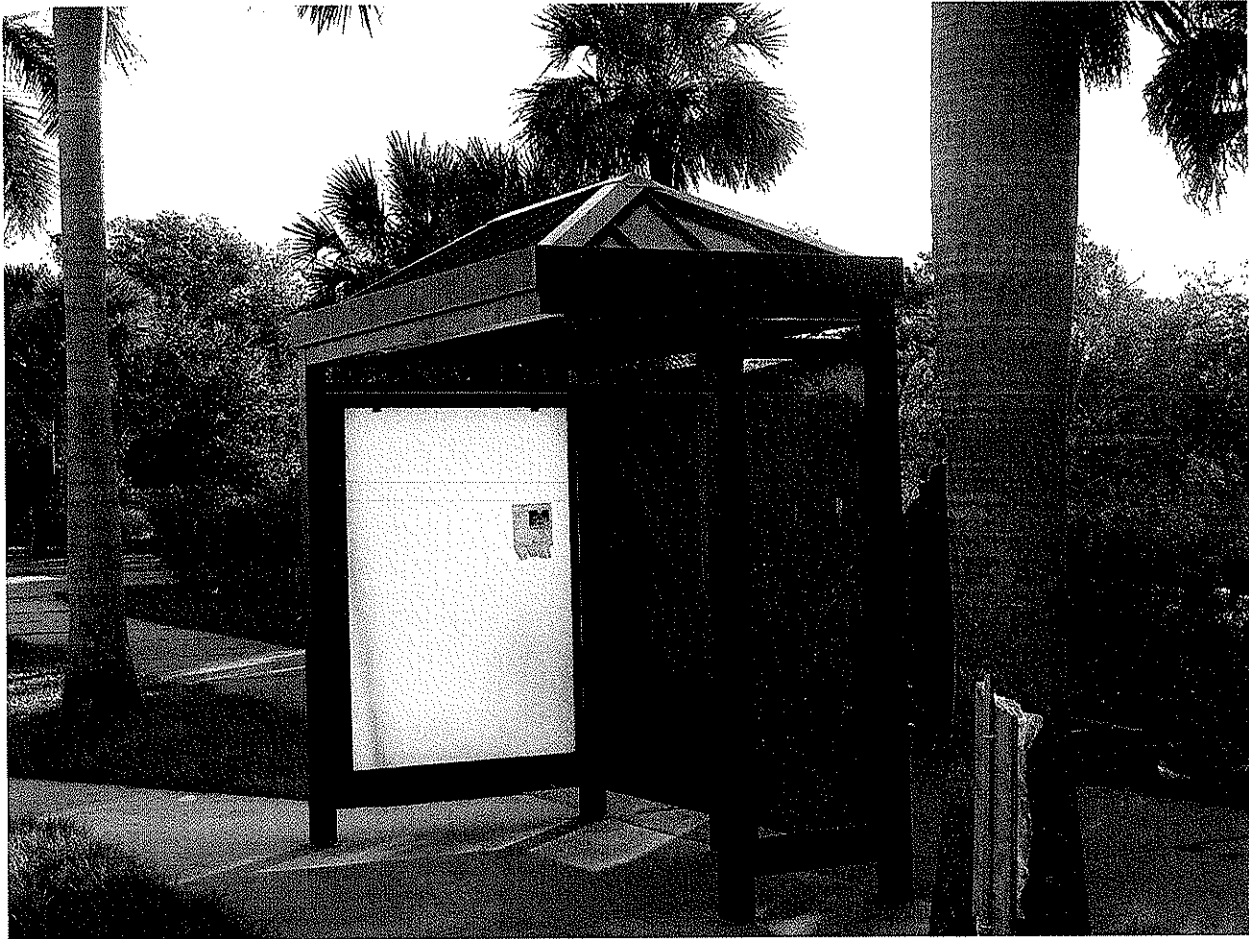



**BRASCO
INTERNATIONAL**

1000 Mt. Elliott
Detroit, MI 48207
PHONE: (800) 893-3665
FAX: (313) 393-0499
WEB: www.brasco.com

Reference

Pinellas Suncoast Transit Authority
3201 Scherer
St. Petersburg, FL 33716

Danny Hazard, PSTA
Phone: (727) 540-1838 Email: dhazard@psta.net

Hurricane Rated Advertising Shelters – Ongoing Contract

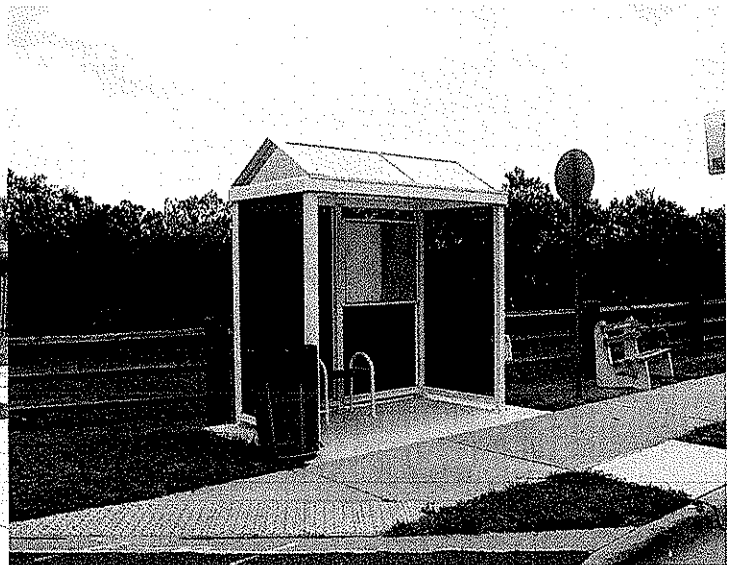
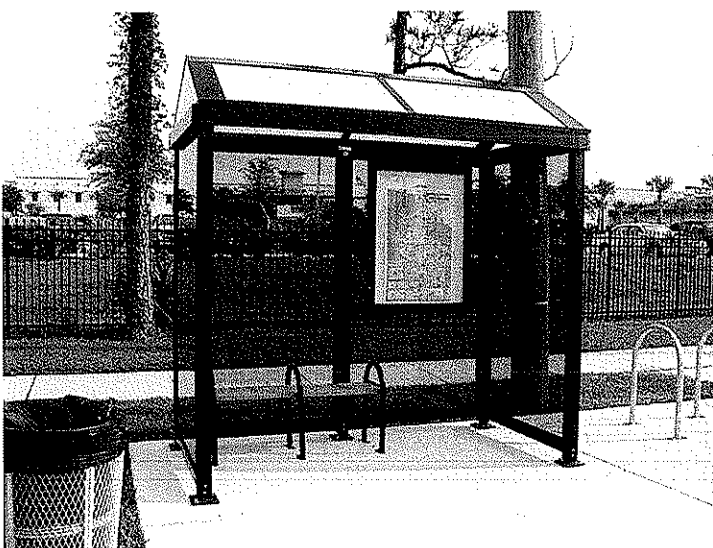



BRASCO
INTERNATIONAL

1000 Mt. Elliott
Detroit, MI 48207
PHONE: (800) 893-3665
FAX: (313) 393-0499
WEB: www.brasco.com

Reference

Collier Area Transit
2901 County Barn Rd.
Naples, FL 34112

Bob Petersen, Collier Area Transit
Phone: (239) 2525871 Email: bobpetersen@colliergov.net

Hurricane Rated Shelters – Ongoing Contract





BRASCO
INTERNATIONAL

1000 Mt. Elliott
Detroit, MI 48207
PHONE: (800) 893-3665
FAX: (313) 393-0499
WEB: www.brasco.com

Reference

Potomac & Rappahannock Transportation Commission
14700 Potomac Mills Road
Woodbridge, VA 22192

Anthony Foster
Phone: (703) 580-6147 Email: afoster@omniride.com

Passenger Waiting Shelters with Solar Lighting – Ongoing Contract





BRASCO
INTERNATIONAL

1000 Mt. Elliott
Detroit, MI 48207
PHONE: (800) 893-3665
FAX: (313) 393-0499
WEB: www.brasco.com

Reference

Regional Transportation Commission
PO Box 30002
Reno, NV 89520

Tina Wu

Phone: (775) 335-1908 Email: twu@rtcwashoe.com

Passenger Waiting Shelters with Solar Lighting – Ongoing Contract

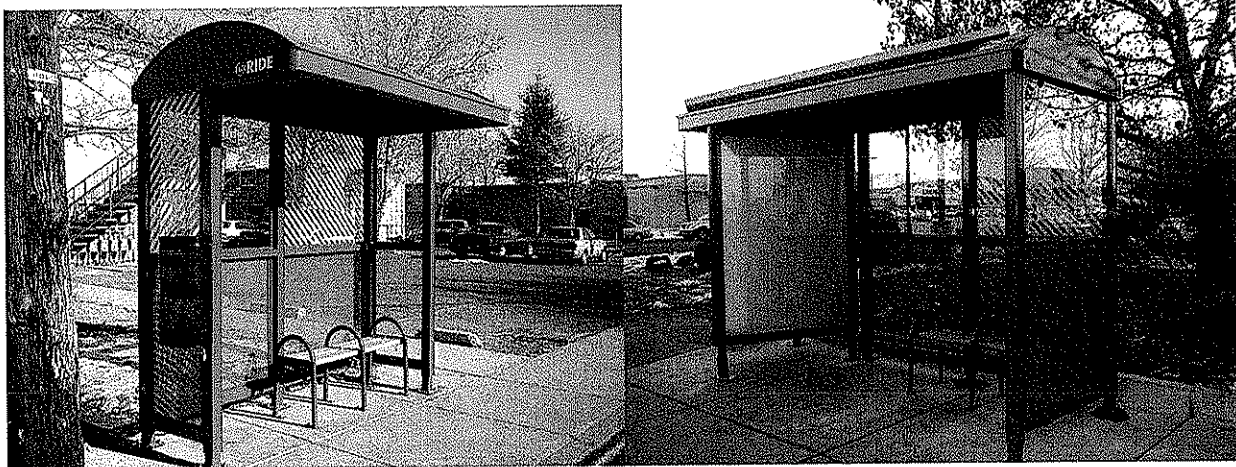



**BRASCO
INTERNATIONAL**

1000 Mt. Elliott
Detroit, MI 48207
PHONE: (800) 893-3665
FAX: (313) 393-0499
WEB: www.brasco.com

Concrete Pad Specifications

Brasco International, Inc shelters require a concrete pad to anchor to. We recommend that the concrete pads are a minimum of 4" thick or greater, 3000 PSI or greater, and the concrete pad should extend about 1' past each outer column of the shelters. The installer should always consult the local building codes which supersede our concrete requirements. Brasco will provide detailed pad drawings, if required, upon request.

Shelter Size: 3' deep x 9' width Approximate Concrete Pad Size: 5' deep x 11' width

Shelter Size: 3' deep x 12' width Approximate Concrete Pad Size: 5' deep x 14' width

Shelter Size: 5' deep x 7' width Approximate Concrete Pad Size: 7' deep x 9' width

Shelter Size: 5' deep x 9' width Approximate Concrete Pad Size: 7' deep x 11' width

Shelter Size: 5' deep x 10' width Approximate Concrete Pad Size: 7' deep x 12' width

Shelter Size: 5' deep x 12' width Approximate Concrete Pad Size: 7' deep x 14' width

THE FOLLOWING TOOLS ARE REQUIRED FOR INSTALLATION

- Drill Motor w/ #11 and 1/4" Drill Bits
- Heavy Duty Drill Motor w/ 1/2" Masonry Drill Bit
- Steel Hammer
- Dead Blow Hammer
- Heavy Duty Pop Rivet Tool
- Bubble Level
- 7/16" and 3/4" Sockets w/ Wrench
- Caulk Gun

SUMMARY OF SHELTER FASTENERS PROVIDED



A 3/16" x 3/16" G.R. Aluminum Blind Rivet
Window Sash and Ground Windskirt
Attachment – PART # F-4029



B 3/16" x 3/8" Stainless Steel Blind Rivet –
Bench and Backrest Bracket Attachment
Grillwork Attachment – PART # F-4066



C 1/4" x 1/4" Dome Head Drive Rivet –
Roof Module Attachment – PART # F-4045

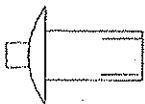

D 1/4" x 3/8" Dome Head Drive Rivet –
Anchor Boot Attachment – PART # F-4043

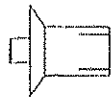

E 1/4" x 3/8" Counter Sunk Drive Rivet –
Frame Attachment – PART # F-4053

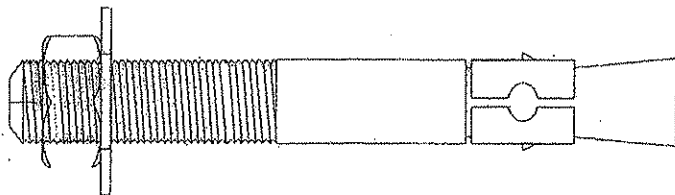

F 1/2" x 3 3/4" Stainless Steel Wedge Anchor
Bolt Ground Attachment – PART # F-4050

SHELTER ANCHOR BOOT STYLES:

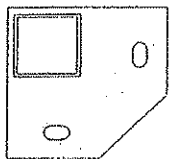

CORNER BOOT
Part # B4642



INTERMEDIATE BOOT
Part # B4630



DOORWAY BOOT
Part # B4643

SHELTER WALL SECTION ASSEMBLY

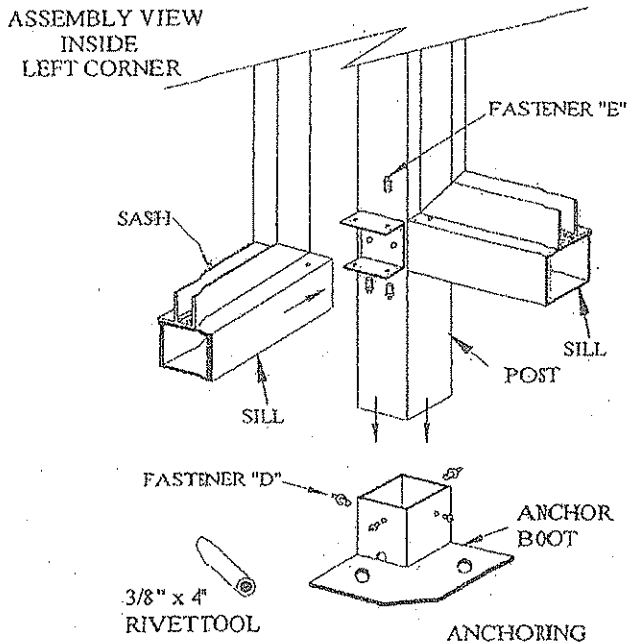
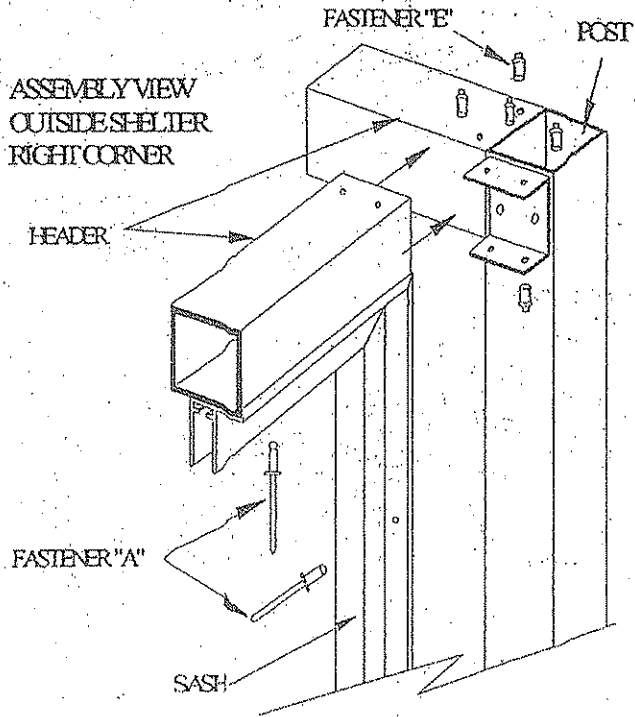

For proper orientation of the shelter, wall sections are viewed by standing in front of the shelter looking in. All wall sections are labeled for assembly.

- Start with the left side wall and the left rear wall sections.
- Begin by setting vertical posts into anchor boots. Orient anchor boot so flanges of boot and eventual anchor bolts will align under the sill.
- Slide header and sill tubes onto corresponding structural clips. Fully engage wall sections until sash lip covers column edge.

These shelters are precision manufactured. Some tapping may be necessary to fully engage tubes over structural clips. Countersunk drive rivet holes will be at a slight offset to hold tube and clip in tension.

- Using tool provided, seat rivets into predrilled holes. Secure connection with (3) 1/4" countersunk drive rivets at each clip.
- Repeat connection technique for all remaining back wall or sidewall sections.
- Insert roof cross brace tube(s) over structural dip(s) on back wall header beam.
- Attach frontheader or optional front windscreen by spreading side wall sections until header tube engages over structural clip(s). Insert roof cross brace tube(s) over front structural clips. Secure with countersunk drive rivets.
- Where wall sections connect, use #11 drill bit (.191 dia) and drill through pilot holes in sash into corresponding tube.
- Secure sash to tube with 3/16" x 3/8" aluminum blind rivets.
- With wall sections assembled; square and plumb wall sections. Use 1" shims provided to pitch shelter drainage to the rear. Shims should be placed inside anchor boots to maintain sufficient pitch so water cannot pool. Final leveling can take place prior to anchoring shelter in place.

SHELTER WALL SECTION ASSEMBLY

ASSEMBLY VIEW INSIDE SHELTER - LEFT CORNER

ASSEMBLY VIEW OUTSIDE SHELTER - RIGHT CORNER

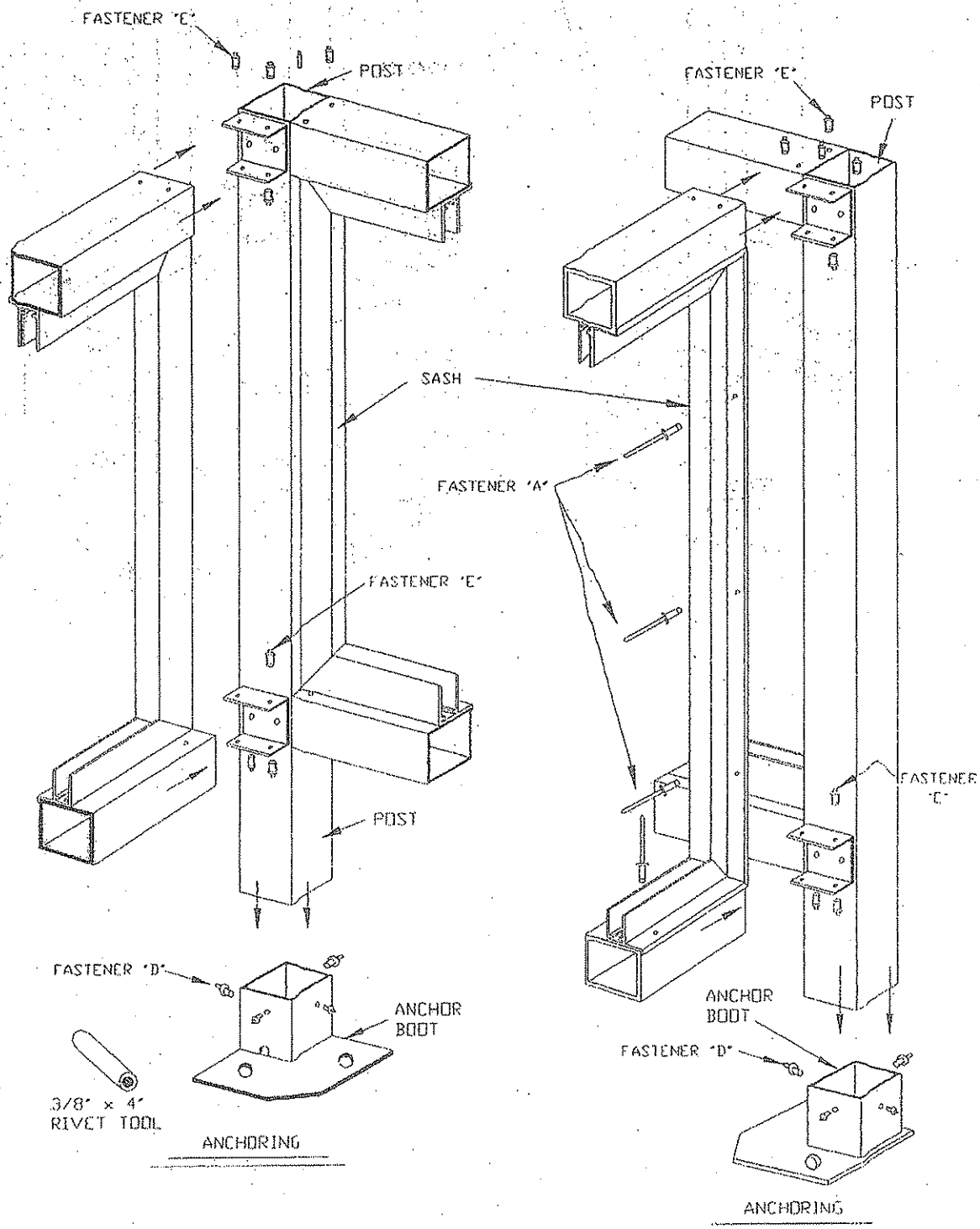

SINGLE ROOF MODULE INSTALLATION

- Be sure shelter frame is square and level
- Clean top of header beams around the entire perimeter of shelter.
- With drain holes located to the rear of the shelter, set roof module onto shelter wall sections.
- Be sure roof module is set completely into shelter frame. Pull down from outside if necessary and hold firm.
- From inside the shelter, using 1/4" drill bit, drill through pilot holes in the self alignment lip of the roof modules into shelter header beams.
- Secure entire perimeter with 1/4" x 1/4" dome head drive rivets. (Fastener "C")

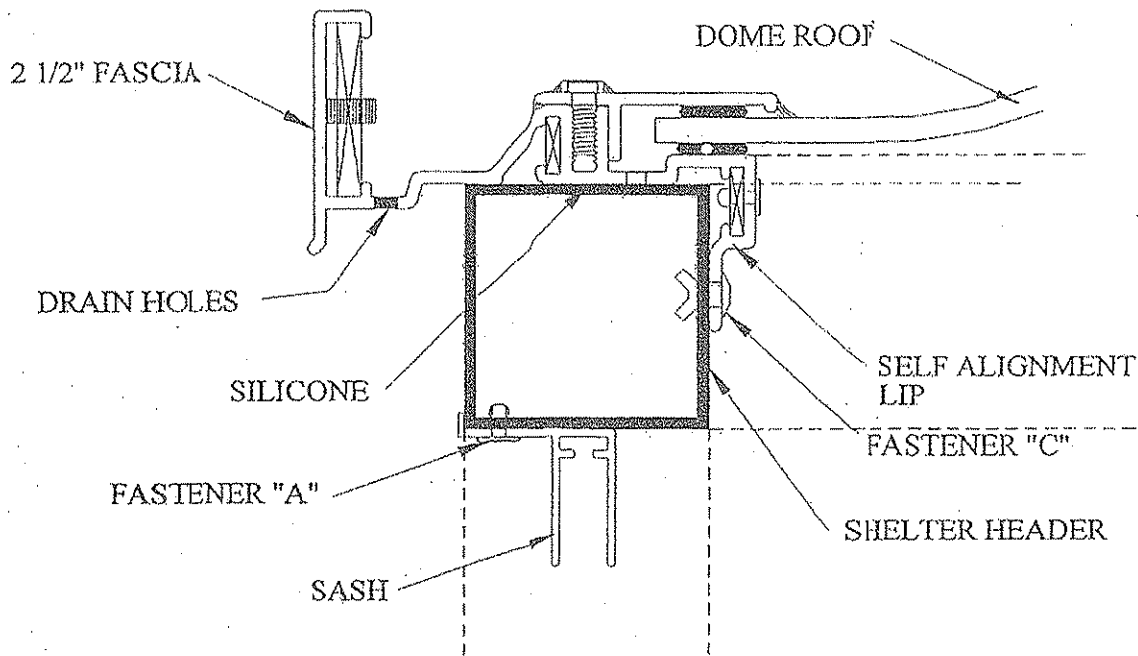

FINAL LEVELING / ANCHORING SHELTER

ORIENT ROOF MODULE
DRAINHOLES
TO REAR

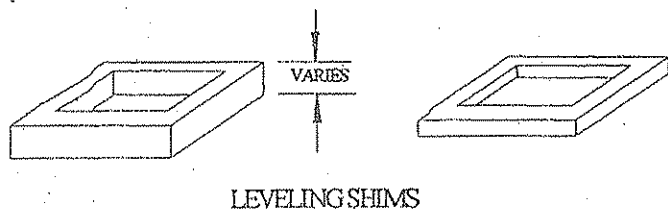
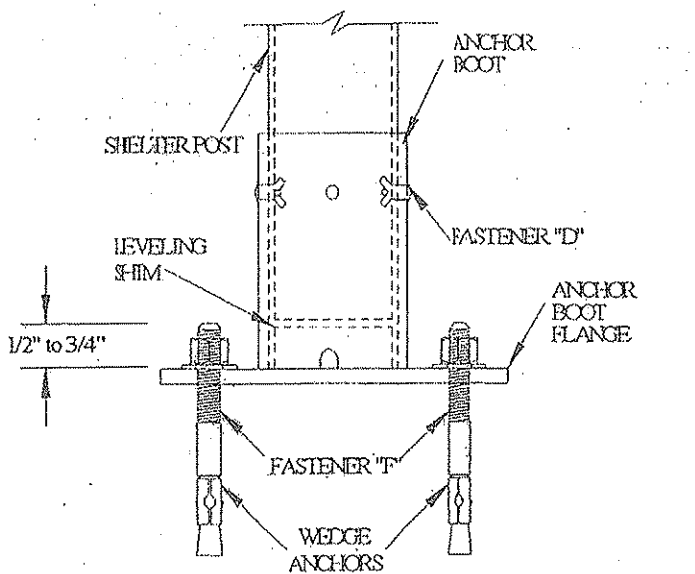
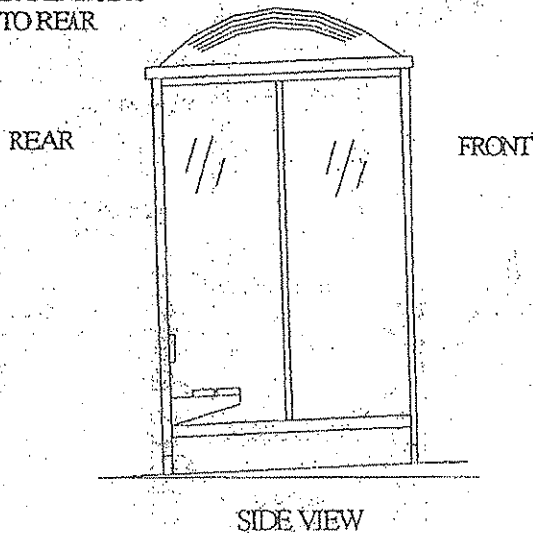

- With the shelter in the proper location, square and plumb wall sections. This can be done using a bubble level and the 3-4-5 squaring formula (from a corner, measure and mark 3' along the side wall, measure and mark 4' along the back wall. The distance between the marks (forming a triangle) needs to be 5'. Adjust accordingly.
- Using a bubble level and leveling shims provided in the hardware kit, pitch shelter to the rear for drainage. Sufficient pitch should be maintained not to pool water in the roof module.
- Mark concrete through holes in anchor boot flanges.
- Move shelter over allowing ample room to drill holes in concrete. Using a 1/2" masonry bit, drill a 3" - 3 1/2" deep hole.
- Relocate shelter over drilled holes.
- Set wedge anchors (Fastener "F") into holes leaving 1/2" to 3/4" exposed thread above surface of anchor boot flange. Apply flat washer, lock washer, and nut onto bolt. Tighten securely.
- Drill through pilot holes in anchor boot into shelter leg (1/4" bit). Secure each anchor boot with (4) 1/4" x 3/8" dome head drive rivets. (Fastener "D")

CLEANING TIPS

This information is intended to serve as a guide and will be useful in understanding the proper care and maintenance of anodized aluminum. As with any finished product, anodized aluminum requires reasonable care prior to and during installation. Anodized aluminum possesses exceptional resistance to corrosion, discoloration and wear. Upon final installation routine maintenance should commence. The more frequently aluminum is cleaned the easier and less costly succeeding maintenance is:

1. Over-cleaning or excessive rubbing can do more harm than good.
2. Strong solvents or strong cleaner concentrations can cause damage to the finished surface.
3. Avoid abrasive cleaners. Do not use household cleaners that contain abrasives.
4. Abrasive materials like steel wool, abrasive brushes, etc. can wear and harm finishes.
5. Avoid drips and splashes. Remove excess solvents as quickly as possible.
6. Avoid temperature extremes. Heat accelerates chemical reactions and may evaporate water from cleaning solutions. Extremely low temperatures may result in poor cleaning results. Cleaning under adverse conditions may result in streaking or staining. Ideally, cleaning should be done in shade at moderate temperatures.
7. Do not substitute a heavy-duty cleaner for a frequently used mild cleaner.
8. Do not scour surface.
9. Never use paint removers, aggressive alkaline, acid or abrasive cleaners.
10. Do not use tri-sodium phosphate, highly alkaline, high acid based cleaners.
11. Always do a surface test in an inconspicuous area.
12. Follow manufactures recommendations for mixing and diluting cleaners.
13. Never mix cleaners.
14. To prevent marring, make sure cleaning sponges, cloths, etc. are grit free.
15. Consideration must be given to the effects of drips, splashes and run down to shrubbery, personal equipment, vehicles and other items located near by. Such conditions may affect the timing of the cleaning schedule.

PRODUCTS FOR THE CARE OF ALUMINUM

The following list of proprietary products for the care and cleaning of aluminum has been provided by member companies of the Aluminum Association, and is included merely as an aide in identifying such products and the categories described in the text. No attempt has been made by the Association to evaluate their effectiveness, nor does listing here constitute an endorsement. The list is not to be considered all-inclusive; other products equally suitable for the intended purpose may be available. The responsibility for the selection, determination of suitability, and proper use of the cleaning product is left to the user.

Cleaners

mild soaps and detergents and non-etching cleaners

Aero wash	BASF Wyandotte Corporation, Wyandotte, MI 48192
Aluma-Clean	Coricone Corporation, 550 Frontage Rd., Northfield, IL 60093
Aluminum Cleaner HC-22	Klenzade Products, Div. of Economics Labs, Beloit, WI 48192
ARCAL 101	ARCAL Chemicals, Inc., 223 Westhampton Ave., Seat Pleasant, MD 20027
Cascade/Ivory Liquid/Ivory Snow/ Joy/Thrill	The Procter & Gamble Co., P.O. Box 599 Cincinnati, OH 45202
Cee-Bee A-69m/Cee-Bee A-13/Cee-Bee 280	McGean Chemical Co., 9520 East Cee Bee Dr., Downey, CA 90241
Clepo 83-M-8-S	Frederick Gumm Chemical Co., Inc., 1280 Wall Street West, Lyndhurst, NJ 07071
Fantastic	Toxizo, Division of Morton Norwick Products, Inc., P.O. Box 368, Greenville, SC 29602
Fels Soap Granules	Fels & Co. Div., Purex Corp., 73rd & Woodland Ave., Philadelphia, PA 19138
Fleetline JC4/JC5/111/204	Oakite Products, Inc., 50 Valley Rd., Berkeley Heights, NJ 07922
Flow	Dubois Chemicals, DuBois Tower, Cincinnati, OH 45202
General Surface Cleaner	Fruchauf Division, Fruchauf Corp., Detroit, MI 48232
Glim	Babbit Products, Inc., Lakeville, CT 06039
Lux Liquid/Swan Liquid/Dove Liquid/ Dishwasher All	Lever Bros. Co., 390 Park Ave., New York, NY 10022
Magnuwash/NZL/155-X/1156/921-X3	Magnus Division, Economics Laboratory, Inc., Osborn Bldg, St. Paul, MN 55102
Melo-Mighty	Klix Chemical Co., Inc., 551 Railroad Ave. South, San Francisco, CA 94080
No. 203 Aluminum Cleaner	Solventol Chemical Products, Inc., Romulus, MI 48174
#840-1691 Purg-All	Parr, Inc., 18400 Syracuse Ave., Cleveland, OH 44110
Pencsolve 5/Power Cleaner/Powerlone	Penelone Corp., 74 Hudson Ave., Tenafly, NJ 07670
Pex Liquid Detergent	Peck's Products Co., 610 E. Clarence Ave., St. Louis, MO 63147
Ridosol/Ridoline 53/51/357, P3 Almoxo 18, 19,36	Amchem Products, Inc., Amber, PA 19002
Spray Nine	Knight Oil Corp., 251 North Comrie Ave., Johnstown, NY 12095
Super 815, 815MX	Brunin & Company, Inc., P.O. Box 270-B, Indianapolis, IN 46206
Texolite 100/584	Texo Corporation, 2801 Highland Ave., Cincinnati, OH 45212
Trait-R-Wash	Kool Seal, 8001 Franklin Blvd., Cleveland, OH 44102
Vari-Kleen, Spray White	Richardson Company, Allied-Kelite Products Div. 2400 E. Denon Ave., Des Plaines, IL 60018
West Glo	West Chemical Products Inc., Orchard & West Sts., Long Island City, NY 11101

solvent and emulsion cleaners

Airshow Gr I	Brunin & Company, P.O. Box 270-B, Indianapolis, IN 46206
Actusol/Super-Mul, Expedite, Zolu, Lectro SAF	Dubois, Div. Of chemed Corp., DuBois Tower, Fountain Square, Cincinnati OH 45202
Cee-Bee R-677/Cee-Bee C-50 468/Emlon	McGean Chemical Co., 9520 East Cee Bee Dr., Downey, CA 90241
Inhibisol/old Salt Degreaser/ Navee 42/Navitone	BASF Wyandotte Corp., Chemical Specialties Div., Wyandotte, MI 48192
Tri-Ethane	Penelone Corp., 74 Hudson St., Tenafly, NJ 07670
Turco Solv/Kwik Solv	PPG Industries, One Gateway Center, Pittsburgh, PA 15222
W64 C C1	Turco Products, Div. Of Purex Corp. Ltd. Wilmington, CA 09749
	The Sherwin Williams Co. 101 Propect Ave. N.W., Cleveland, OH 44101

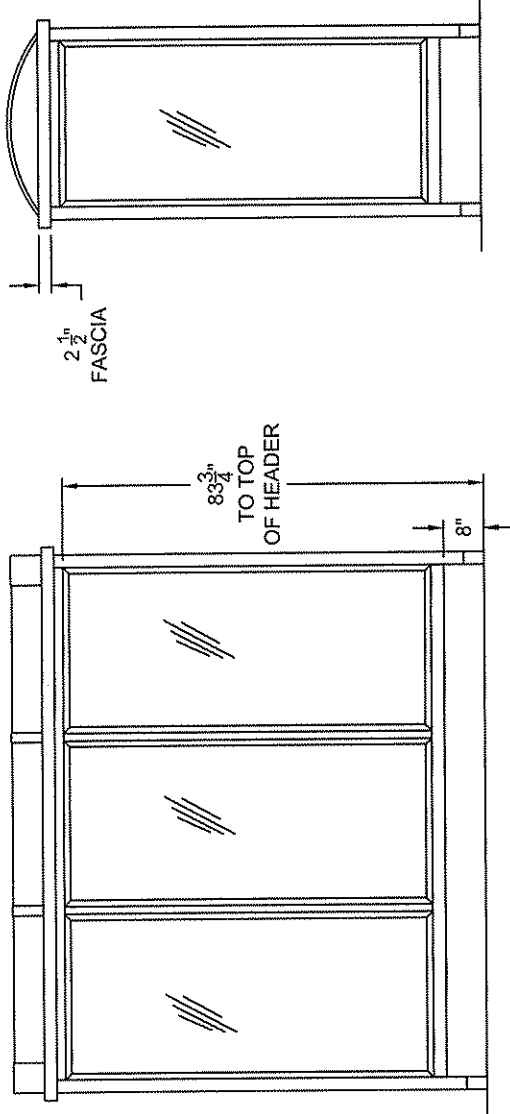

FRONT ELEVATION

SIDE ELEVATION

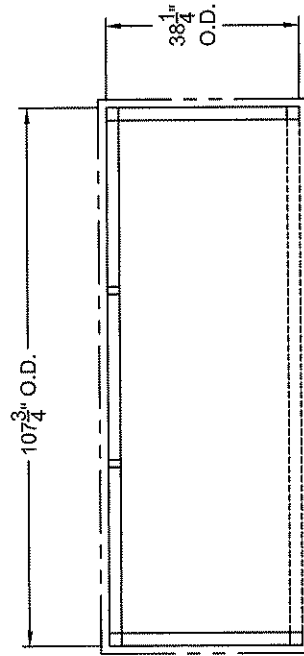

FLOOR PLAN

SPECIFICATIONS:
 ALUMINUM STRUCTURE - COLOR TBD
 1/4" BRONZE STRUCTURED POLYCARBONATE GLAZING
 OPTIONAL STEEL OR ALUMINUM PERFORATED PANEL GLAZING
 ALUMINUM BARREL VAULT ROOF WITH FASCIA/GUTTER SYSTEM - COLOR TBD

	BRASCO INTERNATIONAL, INC. 1000 MT. ELLIOTT DETROIT, MICHIGAN 48207 1-800-893-3665 WWW.BRASCO.COM	CUSTOMER: STATE OF WEST VIRGINIA PROJECT: TRANSIT SHELTERS MODEL: SLIMLINE - SL309	DESIGNER: MGC DATE: 3-15-10 SHEET: 1
	THIS DRAWING IS PROPRIETARY AND IS FOR THE SOLE USE OF OUR CUSTOMERS AND MAY NOT BE REPRODUCED OR COPIED WITHOUT WRITTEN PERMISSION FROM BRASCO INTERNATIONAL.		

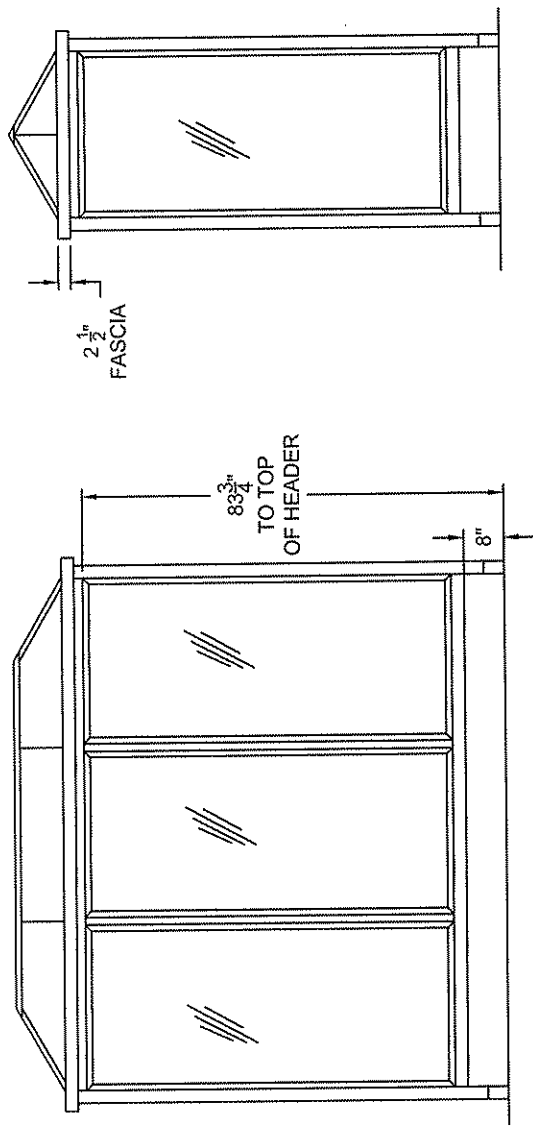

FRONT ELEVATION

SIDE ELEVATION

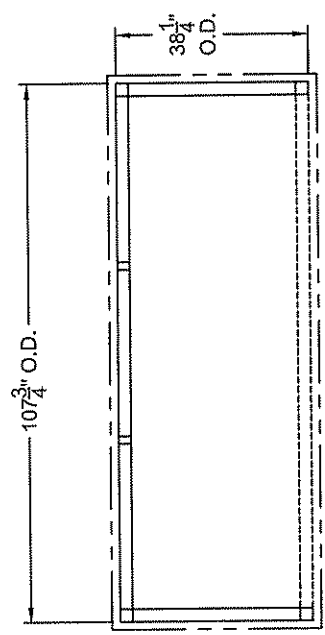

FLOOR PLAN

SPECIFICATIONS:
 ALUMINUM STRUCTURE - COLOR TBD
 1/4" BRONZE STRUCTURED POLYCARBONATE GLAZING
 OPTIONAL STEEL OR ALUMINUM PERFORATED PANEL GLAZING
 ALUMINUM STANDING SEAM HIP ROOF WITH FASCIA/GUTTER SYSTEM - COLOR TBD

	BRASCO INTERNATIONAL, INC. 1000 MT. ELLIOTT DETROIT, MICHIGAN 48207 1-800-893-3665 WWW.BRASCO.COM		CUSTOMER: STATE OF WEST VIRGINIA
	THIS DRAWING IS PROPRIETARY AND IS FOR THE SOLE USE OF OUR CUSTOMERS AND MAY NOT BE REPRODUCED OR COPIED WITHOUT WRITTEN PERMISSION FROM BRASCO INTERNATIONAL.		PROJECT: TRANSIT SHELTERS
			DESIGNER: MGC DATE: 3-15-10 SHEET: 1

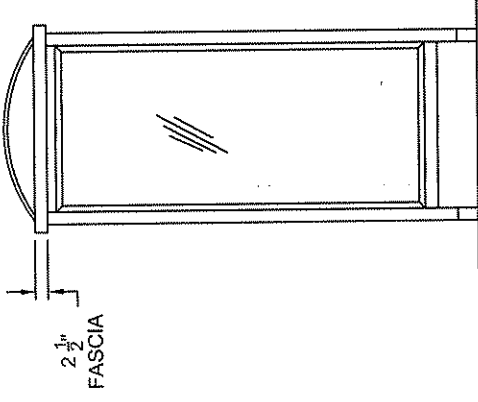

SIDE ELEVATION

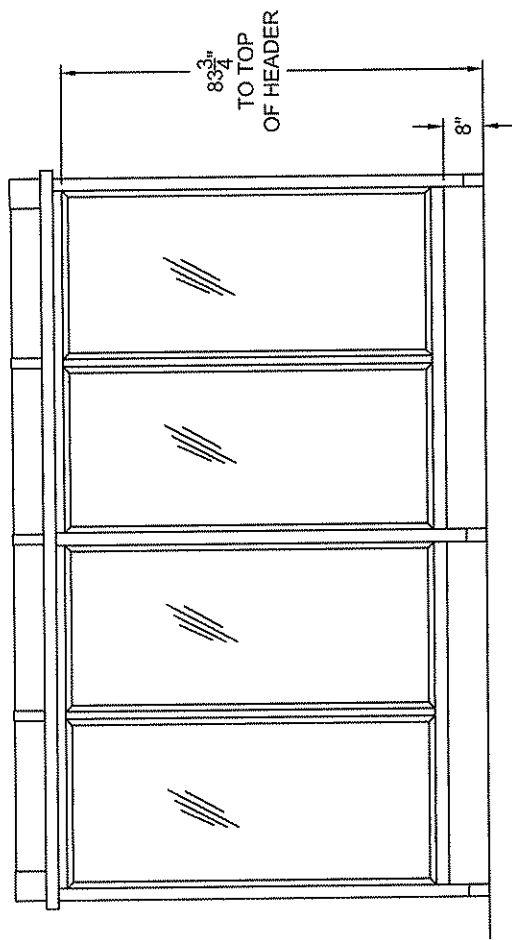

FRONT ELEVATION

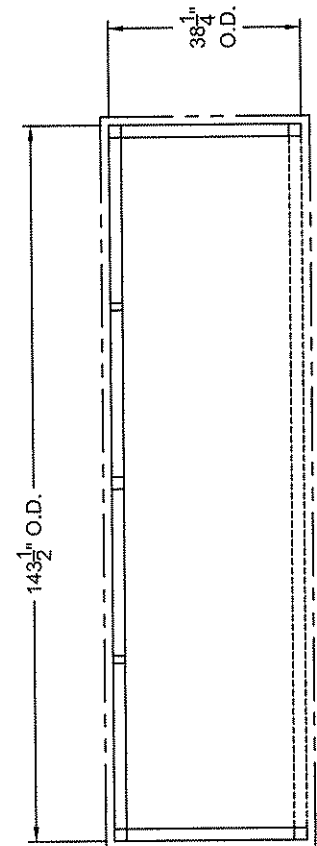

FLOOR PLAN

SPECIFICATIONS:
 ALUMINUM STRUCTURE - COLOR TBD
 1/4" BRONZE STRUCTURED POLYCARBONATE GLAZING
 OPTIONAL STEEL OR ALUMINUM PERFORATED PANEL GLAZING
 ALUMINUM BARREL VAULT ROOF WITH FASCIA/GUTTER SYSTEM - COLOR TBD

	BRASCO INTERNATIONAL, INC. 1000 MT. ELLIOTT DETROIT, MICHIGAN 48207 1-800-893-3665 WWW.BRASCO.COM	CUSTOMER: STATE OF WEST VIRGINIA PROJECT: TRANSIT SHELTERS MODEL: SLIMLINE - SL312	DESIGNER: MGC DATE: 3-15-10 SHEET: 1
	THIS DRAWING IS PROPRIETARY AND IS FOR THE SOLE USE OF OUR CUSTOMERS AND MAY NOT BE REPRODUCED OR COPIED WITHOUT WRITTEN PERMISSION FROM BRASCO INTERNATIONAL.		

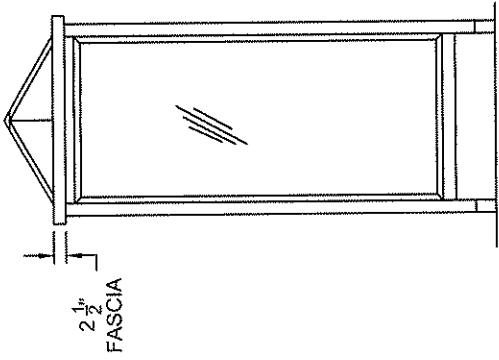

SIDE ELEVATION

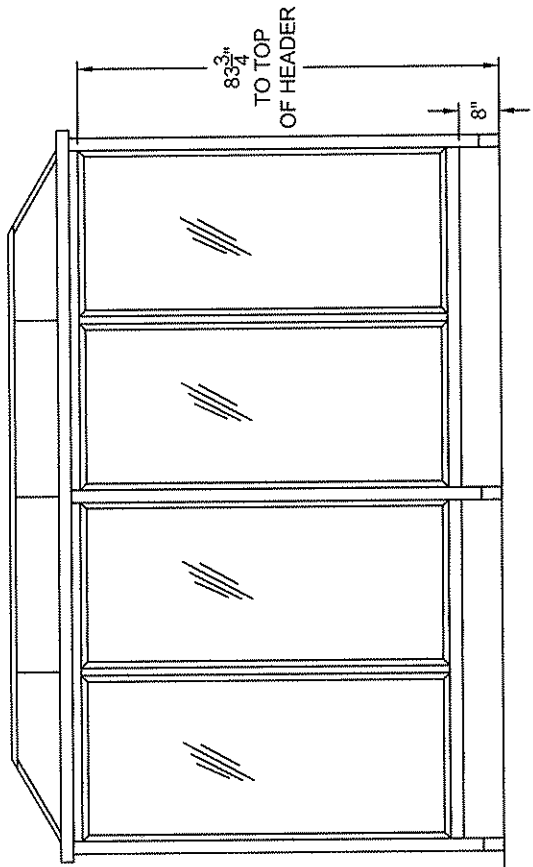

FRONT ELEVATION

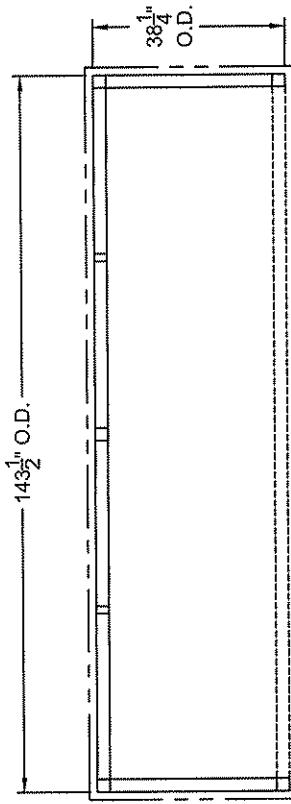

FLOOR PLAN

SPECIFICATIONS:
 ALUMINUM STRUCTURE - COLOR TBD
 1/4" BRONZE STRUCTURED POLYCARBONATE GLAZING
 OPTIONAL STEEL OR ALUMINUM PERFORATED PANEL GLAZING
 ALUMINUM STANDING SEAM HIP ROOF WITH FASCIA/GUTTER SYSTEM - COLOR TBD

	BRASCO INTERNATIONAL, INC. 1000 MT. ELLIOTT DETROIT, MICHIGAN 48207 1-800-893-3665 WWW.BRASCO.COM		CUSTOMER: STATE OF WEST VIRGINIA	DESIGNER: MGC
	THIS DRAWING IS PROPRIETARY AND IS FOR THE SOLE USE OF OUR CUSTOMERS AND MAY NOT BE REPRODUCED OR COPIED WITHOUT WRITTEN PERMISSION FROM BRASCO INTERNATIONAL.		PROJECT: TRANSIT SHELTERS	DATE: 3-15-10
	MODEL: SLIMLINE - SL312		SHEET: 1	

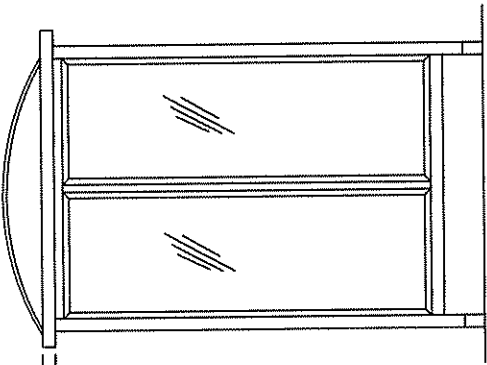

2 1/2"
FASCIA

SIDE ELEVATION

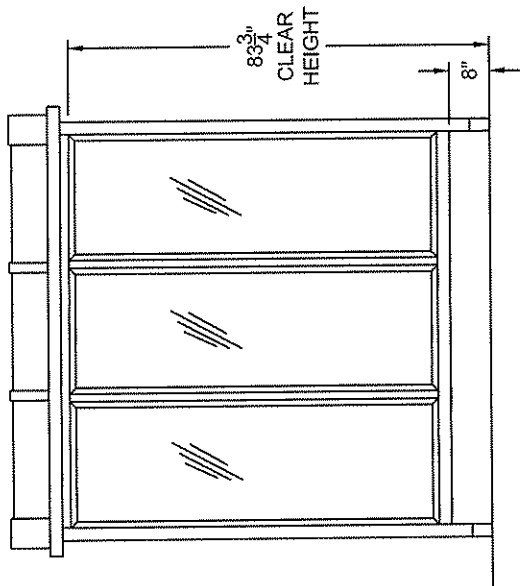

83 3/4"
CLEAR
HEIGHT

8"

FRONT ELEVATION

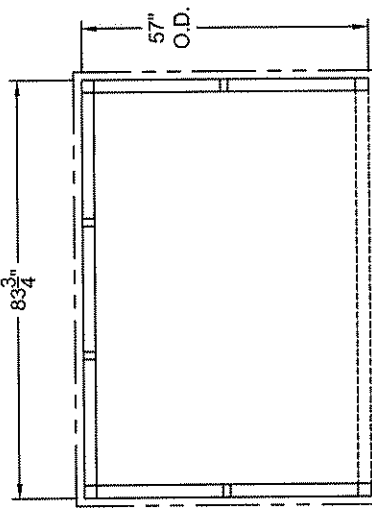

83 3/4"

57"
O.D.

FLOOR PLAN

SPECIFICATIONS:
 ALUMINUM STRUCTURE - COLOR TBD
 1/4" BRONZE STRUCTURED POLYCARBONATE GLAZING
 OPTIONAL STEEL OR ALUMINUM PERFORATED PANEL GLAZING
 ALUMINUM BARREL VAULT ROOF WITH FASCIA/GUTTER SYSTEM - COLOR TBD

	BRASCO INTERNATIONAL, INC. 1000 MT. ELLIOTT DETROIT, MICHIGAN 48207 1-800-893-3665 WWW.BRASCO.COM		CUSTOMER: STATE OF WEST VIRGINIA	DESIGNER: MGC
	<small>THIS DRAWING IS PROPRIETARY AND IS FOR THE SOLE USE OF OUR CUSTOMERS AND MAY NOT BE REPRODUCED OR COPIED WITHOUT WRITTEN PERMISSION FROM BRASCO INTERNATIONAL.</small>		PROJECT: TRANSIT SHELTERS	DATE: 3-15-10
			MODEL: SLIMLINE - SL507	

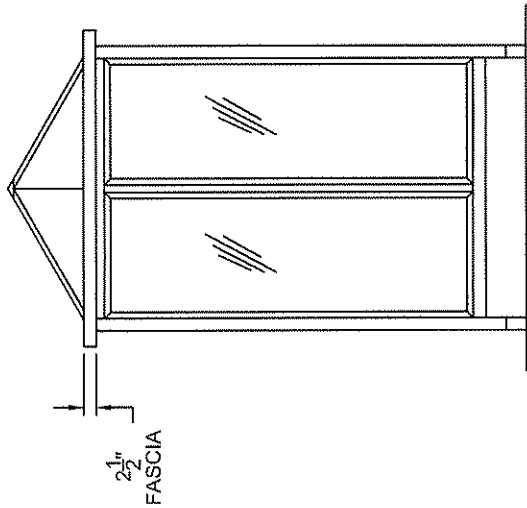

SIDE ELEVATION

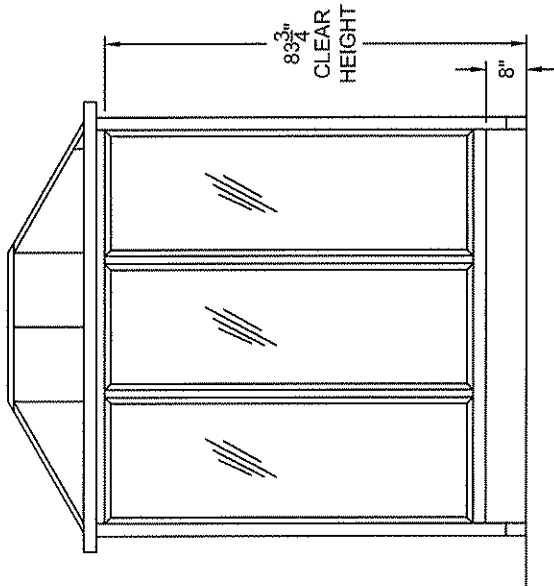

FRONT ELEVATION

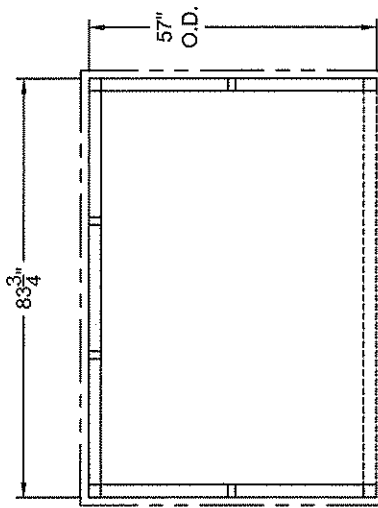

FLOOR PLAN

SPECIFICATIONS:
 ALUMINUM STRUCTURE - COLOR TBD
 1/4" BRONZE STRUCTURED POLYCARBONATE GLAZING
 OPTIONAL STEEL OR ALUMINUM PERFORATED PANEL GLAZING
 ALUMINUM STANDING SEAM HIP ROOF WITH FASCIA/GUTTER SYSTEM - COLOR TBD

	BRASCO INTERNATIONAL, INC. 1000 MT. ELLIOTT DETROIT, MICHIGAN 48207 1-800-893-3665 WWW.BRASCO.COM		CUSTOMER: STATE OF WEST VIRGINIA PROJECT: TRANSIT SHELTERS MODEL: SLIMLINE - SL507	DESIGNER: MGC DATE: 3-15-10 SHEET: 1
	THIS DRAWING IS PROPRIETARY AND IS FOR THE SOLE USE OF OUR CUSTOMERS AND MAY NOT BE REPRODUCED OR COPIED WITHOUT WRITTEN PERMISSION FROM BRASCO INTERNATIONAL.			

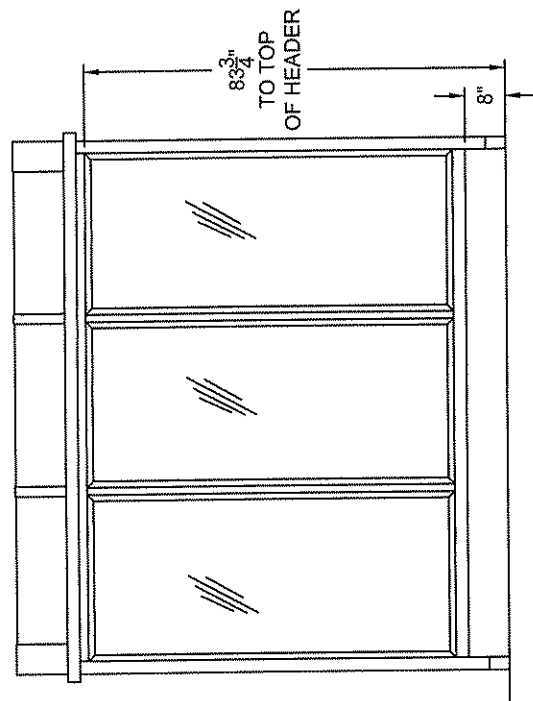

FRONT ELEVATION

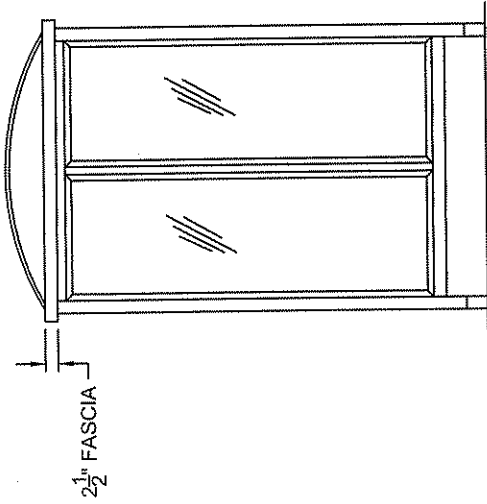

SIDE ELEVATION

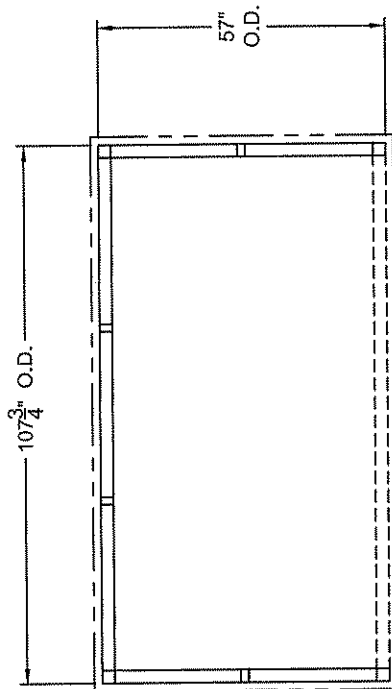

FLOOR PLAN

SPECIFICATIONS:
 ALUMINUM STRUCTURE - COLOR TBD
 1/4" BRONZE STRUCTURED POLYCARBONATE GLAZING
 OPTIONAL STEEL OR ALUMINUM PERFORATED PANEL GLAZING
 ALUMINUM BARREL VAULT ROOF WITH FASCIA/GUTTER SYSTEM - COLOR TBD

	BRASCO INTERNATIONAL, INC. 1000 MT. ELLIOTT DETROIT, MICHIGAN 48207 1-800-893-3665 WWW.BRASCO.COM		CUSTOMER: STATE OF WEST VIRGINIA PROJECT: TRANSIT SHELTERS MODEL: SLIMLINE - SL509	DESIGNER: MGC DATE: 3-15-10 SHEET: 1
	THIS DRAWING IS PROPRIETARY AND IS FOR THE SOLE USE OF OUR CUSTOMERS AND MAY NOT BE REPRODUCED OR COPIED WITHOUT WRITTEN PERMISSION FROM BRASCO INTERNATIONAL.			

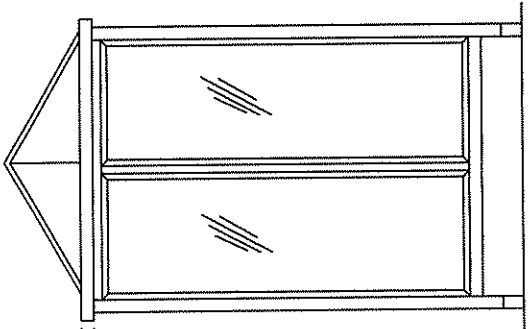

SIDE ELEVATION

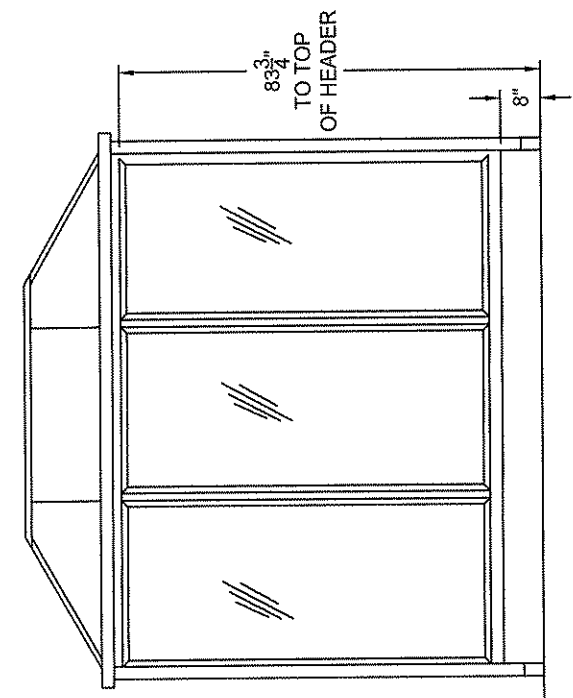

FRONT ELEVATION

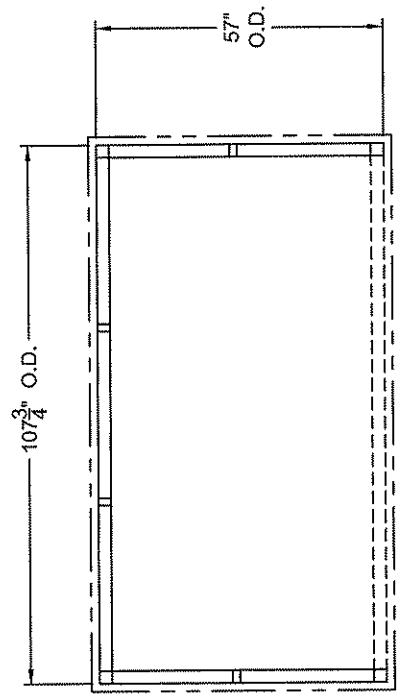

FLOOR PLAN

SPECIFICATIONS:
 ALUMINUM STRUCTURE - COLOR TBD
 1/4" BRONZE STRUCTURED POLYCARBONATE GLAZING
 OPTIONAL STEEL OR ALUMINUM PERFORATED PANEL GLAZING
 ALUMINUM STANDING SEAM HIP ROOF WITH FASCIA/GUTTER SYSTEM - COLOR TBD

	BRASCO INTERNATIONAL, INC. 1000 MT. ELLIOTT DETROIT, MICHIGAN 48207 1-800-893-3665 WWW.BRASCO.COM	CUSTOMER: STATE OF WEST VIRGINIA DESIGNER: MGC
	THIS DRAWING IS PROPRIETARY AND IS FOR THE SOLE USE OF OUR CUSTOMERS AND MAY NOT BE REPRODUCED OR COPIED WITHOUT WRITTEN PERMISSION FROM BRASCO INTERNATIONAL.	PROJECT: TRANSIT SHELTERS DATE: 3-15-10
		MODEL: SLIMLINE - SL509 SHEET: 1

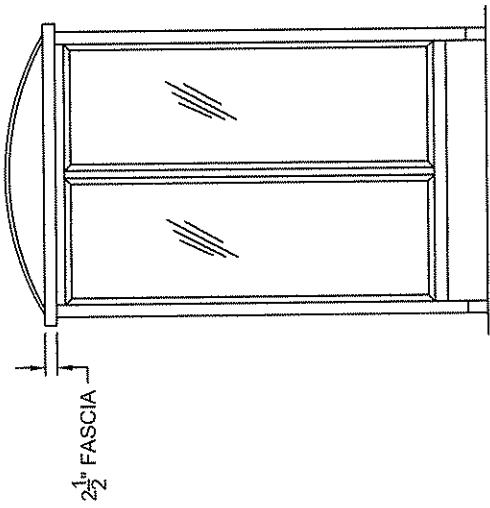

SIDE ELEVATION

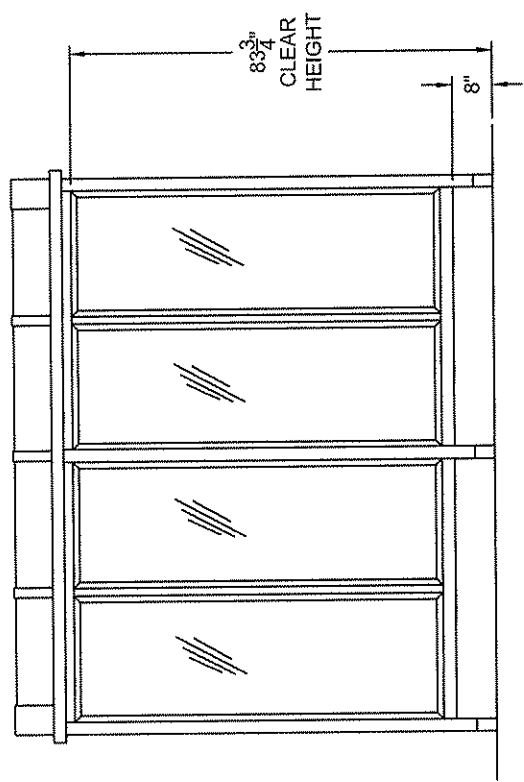

FRONT ELEVATION

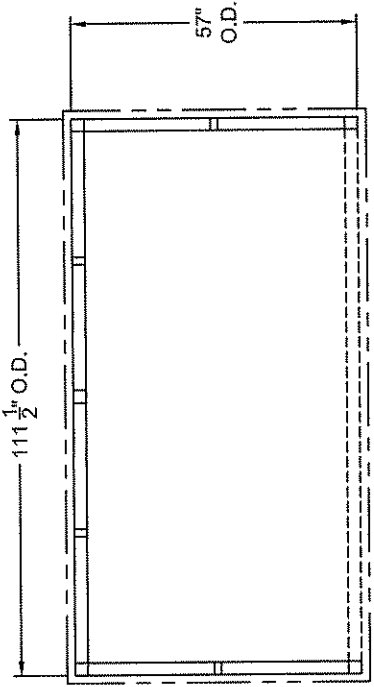

FLOOR PLAN

SPECIFICATIONS:
 ALUMINUM STRUCTURE - COLOR TBD
 1/4" BRONZE STRUCTURED POLYCARBONATE GLAZING
 OPTIONAL STEEL OR ALUMINUM PERFORATED PANEL GLAZING
 ALUMINUM BARREL VAULT ROOF WITH FASCIA/GUTTER SYSTEM - COLOR TBD

	BRASCO INTERNATIONAL, INC. 1000 MT. ELLIOTT DETROIT, MICHIGAN 48207 1-800-893-3665 WWW.BRASCO.COM	CUSTOMER: STATE OF WEST VIRGINIA PROJECT: TRANSIT SHELTERS MODEL: SLIMLINE - SL510	DESIGNER: MGC DATE: 3-15-10 SHEET: 1
	<small>THIS DRAWING IS PROPRIETARY AND IS FOR THE SOLE USE OF OUR CUSTOMERS AND MAY NOT BE REPRODUCED OR COPIED WITHOUT WRITTEN PERMISSION FROM BRASCO INTERNATIONAL.</small>		

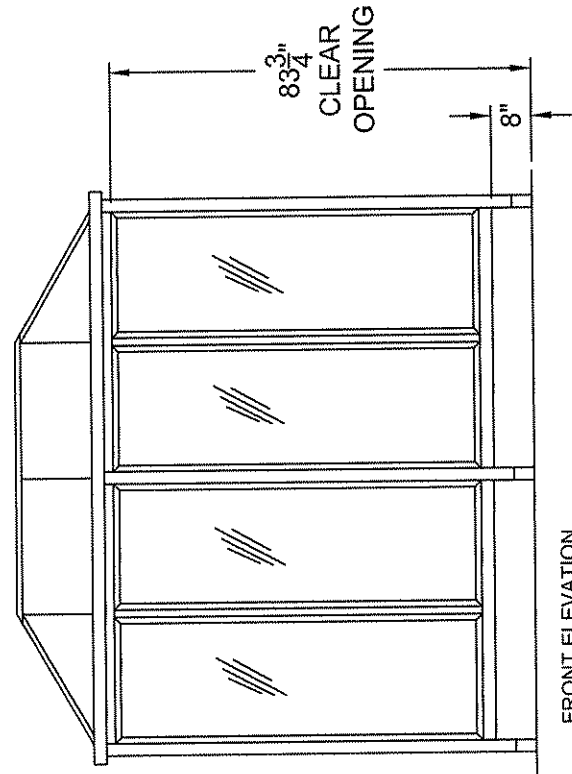

FRONT ELEVATION

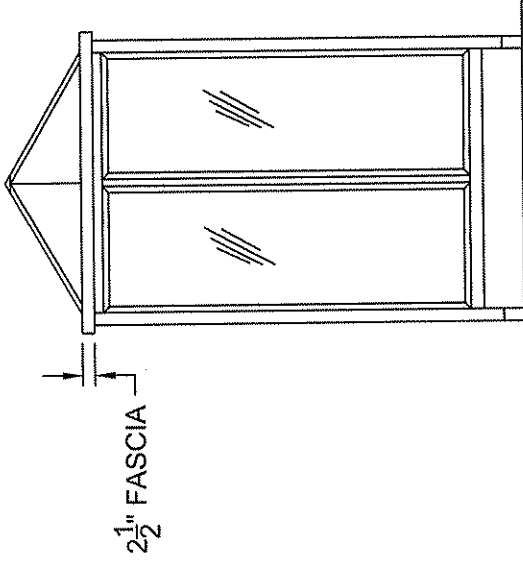

SIDE ELEVATION

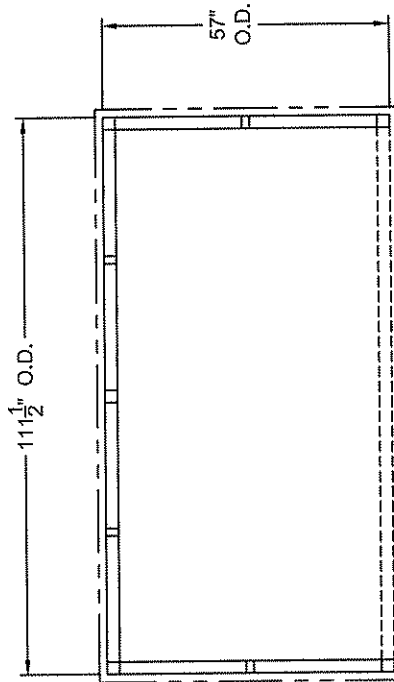

FLOOR PLAN

SPECIFICATIONS:
 ALUMINUM STRUCTURE - COLOR TBD
 1/4" BRONZE STRUCTURED POLYCARBONATE GLAZING
 OPTIONAL STEEL OR ALUMINUM PERFORATED PANEL GLAZING
 ALUMINUM STANDING SEAM HIP ROOF WITH FASCIA/GUTTER SYSTEM - COLOR TBD

	BRASCO INTERNATIONAL, INC. 1000 MT. ELLIOTT DETROIT, MICHIGAN 48207 1-800-893-3665 WWW.BRASCO.COM	CUSTOMER: STATE OF WEST VIRGINIA PROJECT: TRANSIT SHELTERS MODEL: SLIMLINE - SL510	DESIGNER: MGC DATE: 3-15-10 SHEET: 1
	THIS DRAWING IS PROPRIETARY AND IS FOR THE SOLE USE OF OUR CUSTOMERS AND MAY NOT BE REPRODUCED OR COPIED WITHOUT WRITTEN PERMISSION FROM BRASCO INTERNATIONAL.		
	STATE OF WEST VIRGINIA TRANSIT SHELTERS SLIMLINE - SL510		

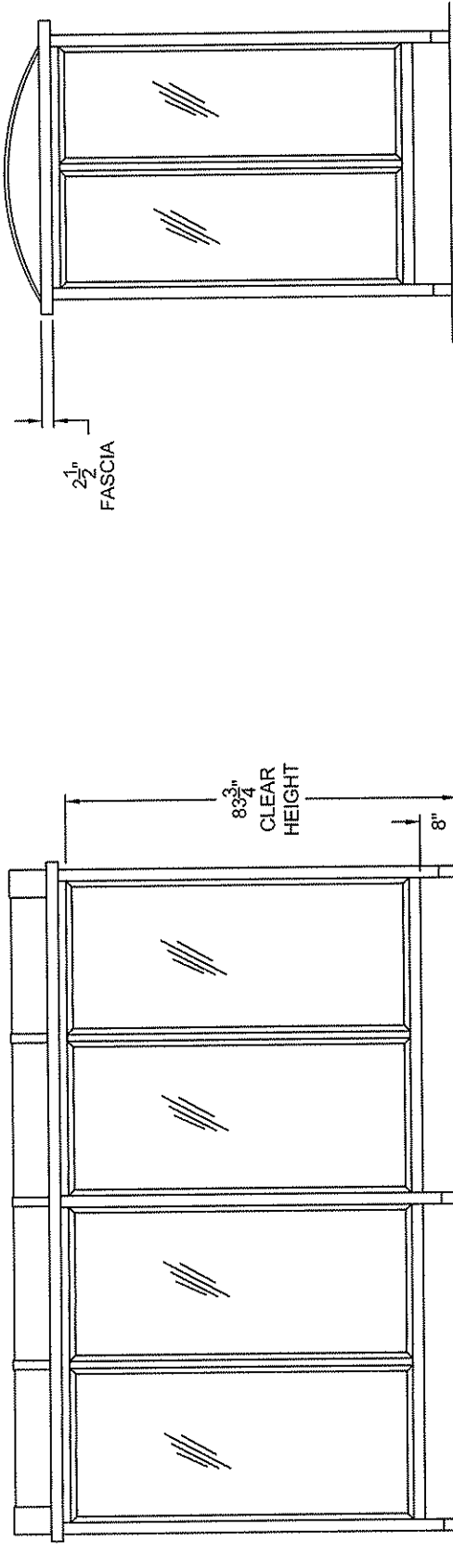



FRONT ELEVATION

SIDE ELEVATION

SPECIFICATIONS:
 ALUMINUM STRUCTURE - COLOR TBD
 1/4" BRONZE STRUCTURED POLYCARBONATE GLAZING
 OPTIONAL STEEL OR ALUMINUM PERFORATED PANEL GLAZING
 ALUMINUM BARREL VAULT ROOF WITH FASCIA/GUTTER SYSTEM - COLOR TBD

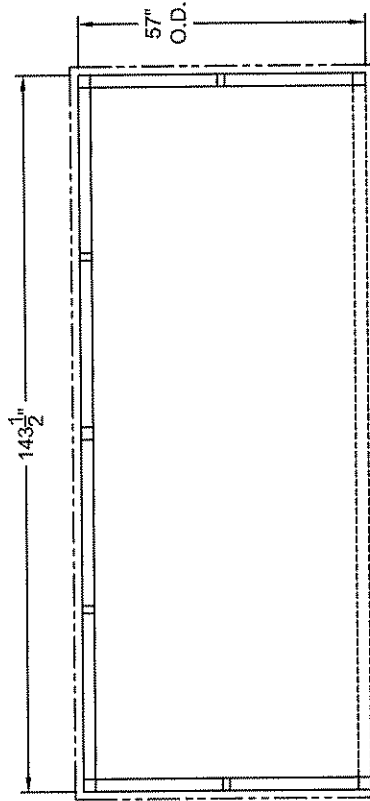
FLOOR PLAN



	BRASCO INTERNATIONAL, INC. 1000 MT. ELLIOTT DETROIT, MICHIGAN 48207 1-800-893-3665 WWW.BRASCO.COM	CUSTOMER: STATE OF WEST VIRGINIA PROJECT: TRANSIT SHELTERS MODEL: SLIMLINE - SL512	DESIGNER: MGC DATE: 3-15-10 SHEET: 1
	THIS DRAWING IS PROPRIETARY AND IS FOR THE SOLE USE OF OUR CUSTOMERS AND MAY NOT BE REPRODUCED OR COPIED WITHOUT WRITTEN PERMISSION FROM BRASCO INTERNATIONAL.		
	SPECIFICATIONS: ALUMINUM STRUCTURE - COLOR TBD 1/4" BRONZE STRUCTURED POLYCARBONATE GLAZING OPTIONAL STEEL OR ALUMINUM PERFORATED PANEL GLAZING ALUMINUM BARREL VAULT ROOF WITH FASCIA/GUTTER SYSTEM - COLOR TBD		

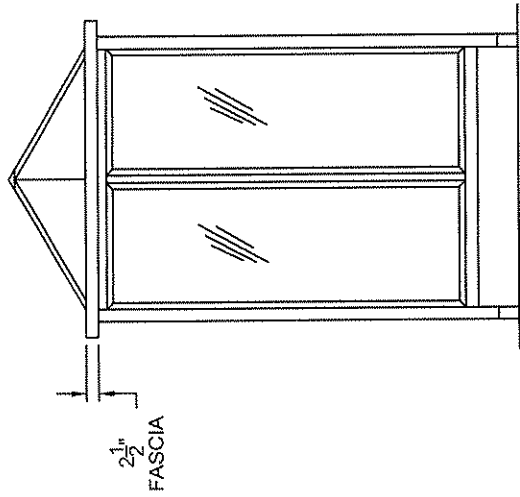

SIDE ELEVATION

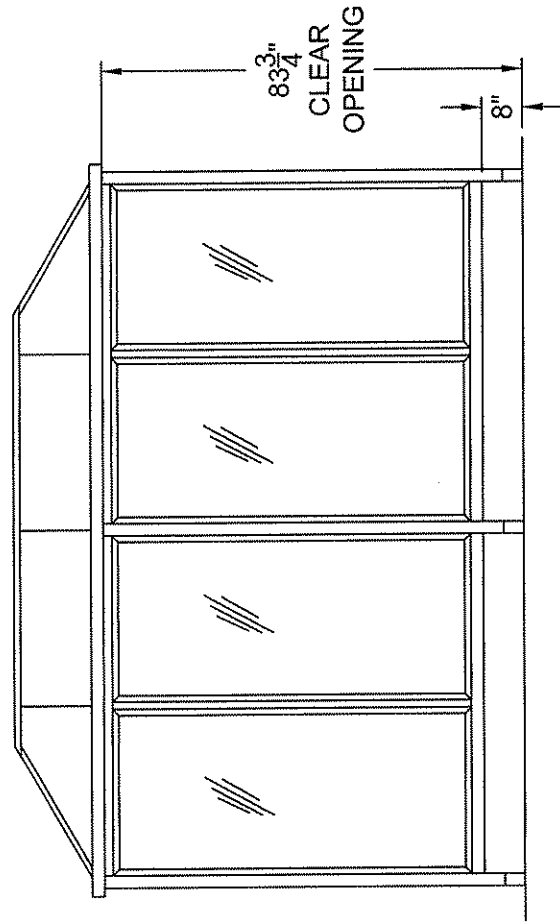

FRONT ELEVATION

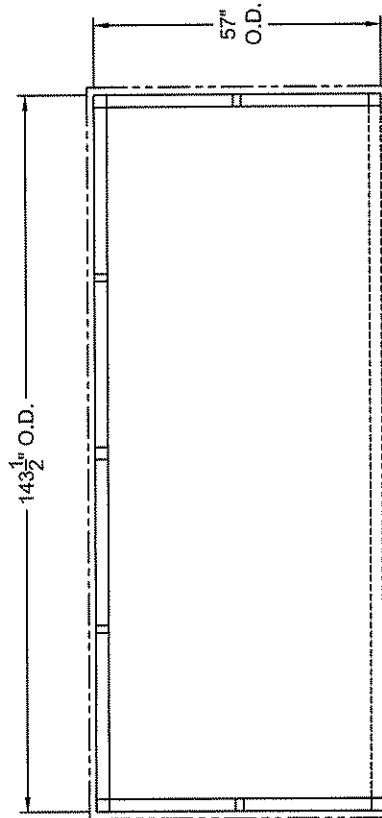

FLOOR PLAN

SPECIFICATIONS:
 ALUMINUM STRUCTURE - COLOR TBD
 1/4" BRONZE STRUCTURED POLYCARBONATE GLAZING
 OPTIONAL STEEL OR ALUMINUM PERFORATED PANEL GLAZING
 ALUMINUM STANDING SEAM HIP ROOF WITH FASCIA/GUTTER SYSTEM - COLOR TBD

	BRASCO INTERNATIONAL, INC. 1000 MT. ELLIOTT DETROIT, MICHIGAN 48207 1-800-893-3665 WWW.BRASCO.COM		CUSTOMER: STATE OF WEST VIRGINIA	DESIGNER: MGC
	THIS DRAWING IS PROPRIETARY AND IS FOR THE SOLE USE OF OUR CUSTOMERS AND MAY NOT BE REPRODUCED OR COPIED WITHOUT WRITTEN PERMISSION FROM BRASCO INTERNATIONAL.		PROJECT: TRANSIT SHELTERS	DATE: 3-15-10
			MODEL: SLIMLINE - SL512	SHEET: 1

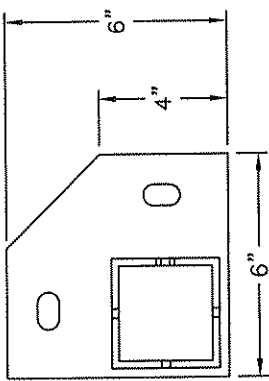
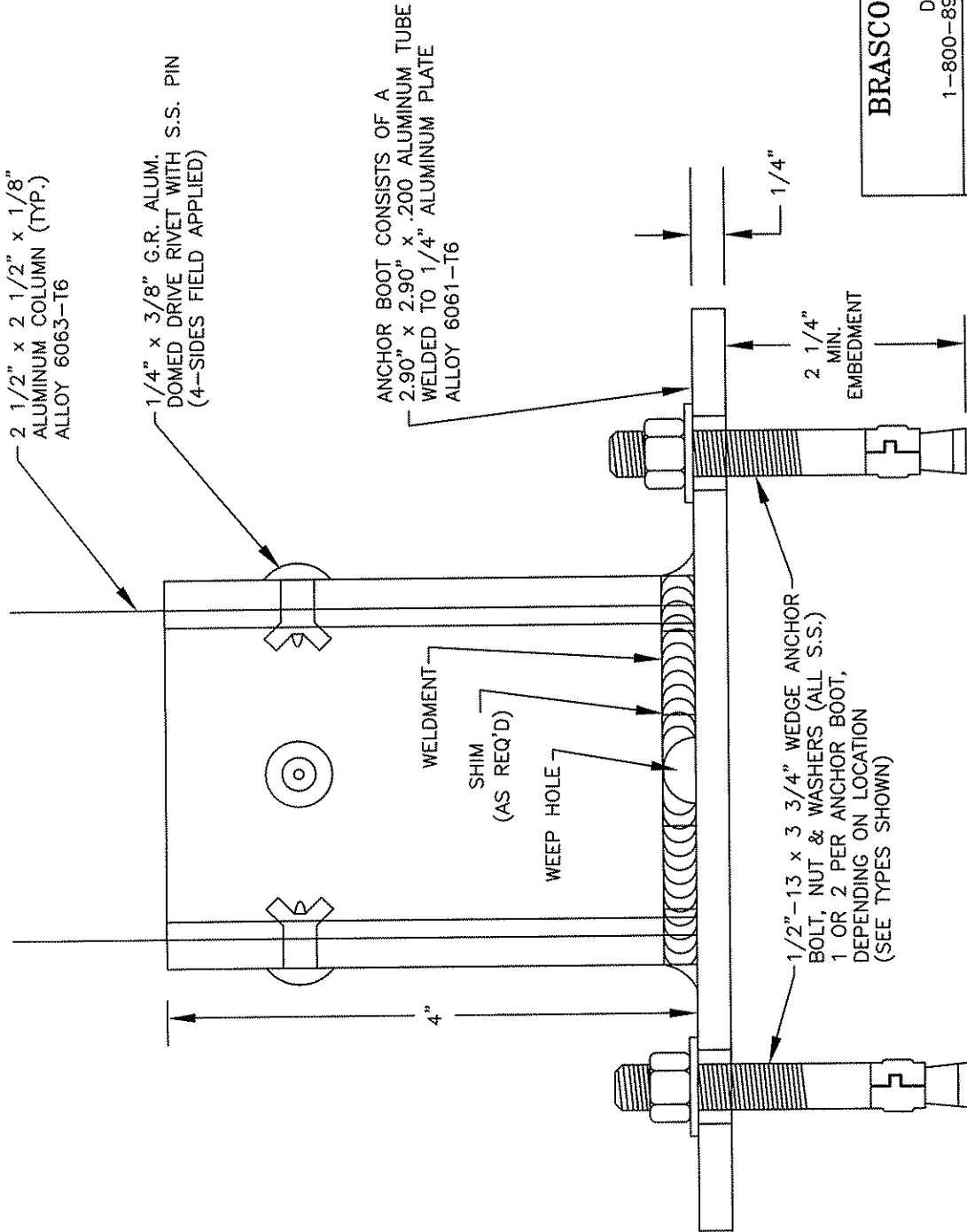

CORNER COLUMN ANCHOR BOOT

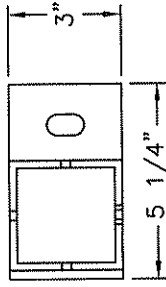

DOOR POST ANCHOR BOOT

BRASCO INTERNATIONAL, INC.

1000 MT. ELLIOTT
 DETROIT, MICHIGAN 48207
 1-800-893-3665 WWW.BRASCO.COM

CUSTOMER	
PROJECT	SLIMLINE SERIES
MODEL	ANCHOR BOOT DETAILS
DRAWN BY	DATE
APPROVED BY	DATE
SCALE	NONE
REV.	



THIS DRAWING IS PROPRIETARY AND IS FOR THE SOLE USE OF OUR CUSTOMERS AND MAY NOT BE REPRODUCED OR COPIED WITHOUT WRITTEN PERMISSION FROM BRASCO INTERNATIONAL.

2 1/2" x 2 1/2" x 1/8"
ALUMINUM HEADER (TYP.)
ALLOY 6063-T5

2 1/2" x 1 1/2" x 1/8"
ALUMINUM MULLION (TYP.)
ALLOY 6063-T6

2 1/4" x 1 1/4" x 1/4"
ALUMINUM FRAME CLIP (TYP.)
ALLOY 6061-T6

1/4" x 3/8" G.R. ALUMINUM
DOME HEAD DRIVE RIVET
1 PER CONNECTION
(ONE SIDE ONLY)

1/4" x 3/8" G.R. ALUMINUM
DOME HEAD DRIVE RIVET
1 PER CONNECTION

10# x 1" S.S. HEX HEAD TEK SCREW
1 PER CONNECTION

2 1/2" x 2 1/2" x 1/8"
ALUMINUM SILL (TYP.)
ALLOY 6063-T6

2 1/2" x 2 1/2" x 1/8"
ALUMINUM COLUMN (TYP.)
ALLOY 6063-T6

1/4-20 x 3/4" HEX BOLT,
FLAT WASHER, LOCK WASHER,
WITH 1/4-20 HEX NUT. (ALL S.S.)
2 PER CONNECTION

2 1/4" x 2 1/4" x 1/4"
ALUMINUM FRAME CLIP (TYP.)
ALLOY 6061-T6

1/4" x 3/8" G.R. ALUMINUM
FLAT HEAD DRIVE RIVET
4 PER CONNECTION

BRASCO INTERNATIONAL, INC.

1000 MT. ELLIOTT
DETROIT, MICHIGAN 48207
1-800-893-3665 WWW.BRASCO.COM

CUSTOMER

PROJECT SLIMLINE SERIES

MODEL INTERNAL CONNECTIONS

DRAWN BY DATE SHEET

APPROVED BY DATE

SCALE NONE REV.

THIS DRAWING IS PROPRIETARY AND IS FOR THE SOLE USE OF
OUR CUSTOMERS AND MAY NOT BE REPRODUCED OR COPIED
WITHOUT WRITTEN PERMISSION FROM BRASCO INTERNATIONAL.



3/16" x 1/4" G.R.
ALUMINUM BLIND RIVET
OUTSIDE ATTACHMENT

3/4"
ENGAGEMENT

1/4" GLAZING

2 1/2" x 2 1/2" x 1/8"
ALUMINUM COLUMN (TYP.)
ALLOY 6063-T6

BLACK PVC
DRY-SET GASKET

2 1/2" x 1 1/2" x 1/8"
ALUMINUM MULLION (TYP.)
ALLOY 6063-T6

MITERED ALUMINUM SASH WITH
1/8" THICK ALUMINUM CORNER KEY
ALLOY 6063-T6

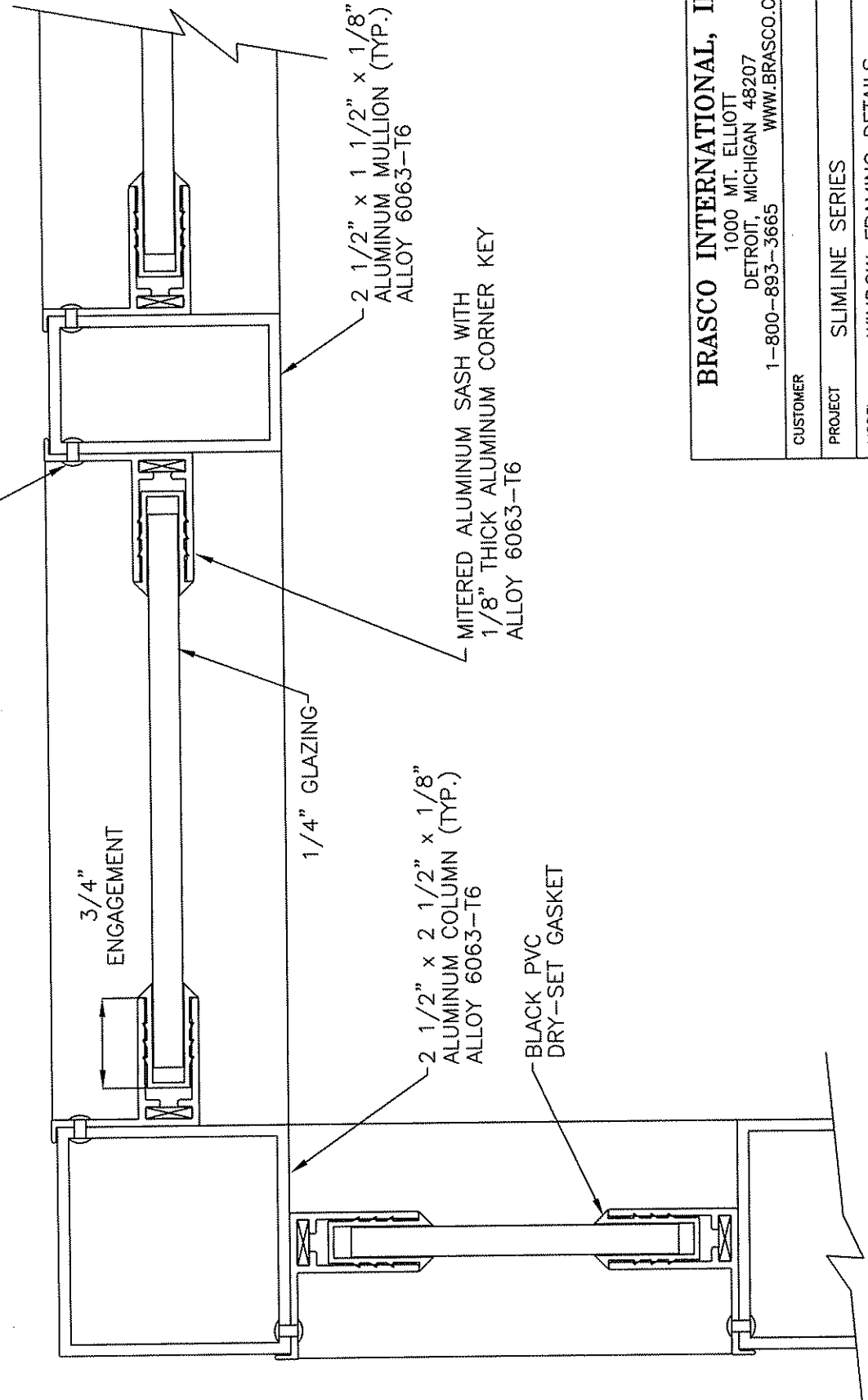

BRASCO INTERNATIONAL, INC.
1000 MT. ELLIOTT
DETROIT, MICHIGAN 48207
1-800-893-3665 WWW.BRASCO.COM

CUSTOMER	
PROJECT	SLIMLINE SERIES
MODEL	WINDOW FRAMING DETAILS
DRAWN BY	DATE
APPROVED BY	DATE
SCALE	NONE
	REV.

SHEET

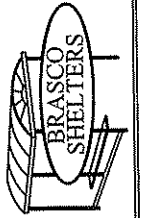

THIS DRAWING IS PROPRIETARY AND IS FOR THE SOLE USE OF OUR CUSTOMERS AND MAY NOT BE REPRODUCED OR COPIED WITHOUT WRITTEN PERMISSION FROM BRASCO INTERNATIONAL.

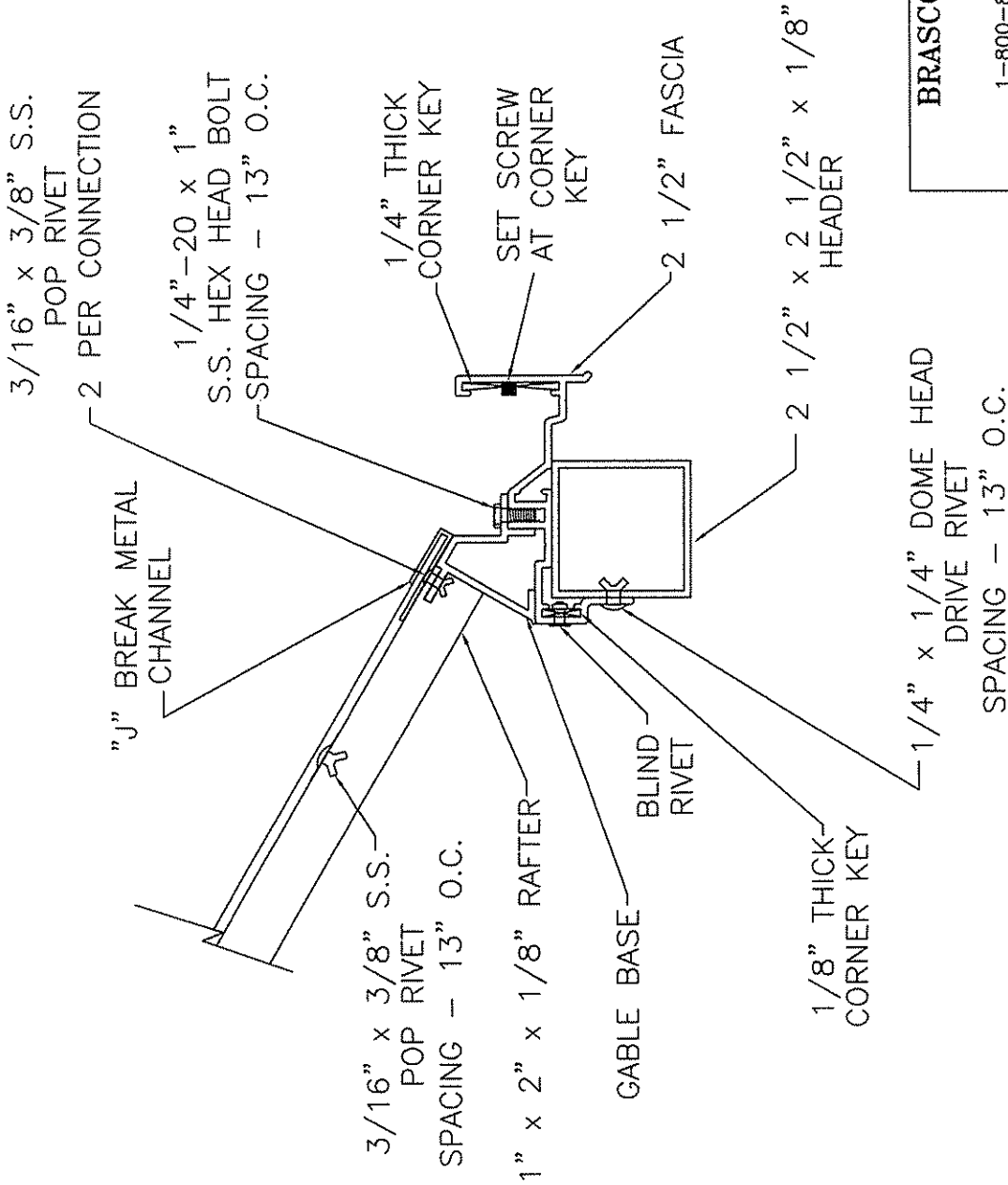

BRASCO INTERNATIONAL, INC.

1000 MT. ELLIOTT
DETROIT, MICHIGAN 48207
1-800-893-3665 WWW.BRASCO.COM

CUSTOMER

PROJECT SLIMLINE SERIES

MODEL STANDING SEAM HIP ROOF DETAIL

DRAWN BY DATE SHEET

APPROVED BY DATE

SCALE NONE REV.

THIS DRAWING IS PROPRIETARY AND IS FOR THE SOLE USE OF OUR CUSTOMERS AND MAY NOT BE REPRODUCED OR COPIED WITHOUT WRITTEN PERMISSION FROM BRASCO INTERNATIONAL



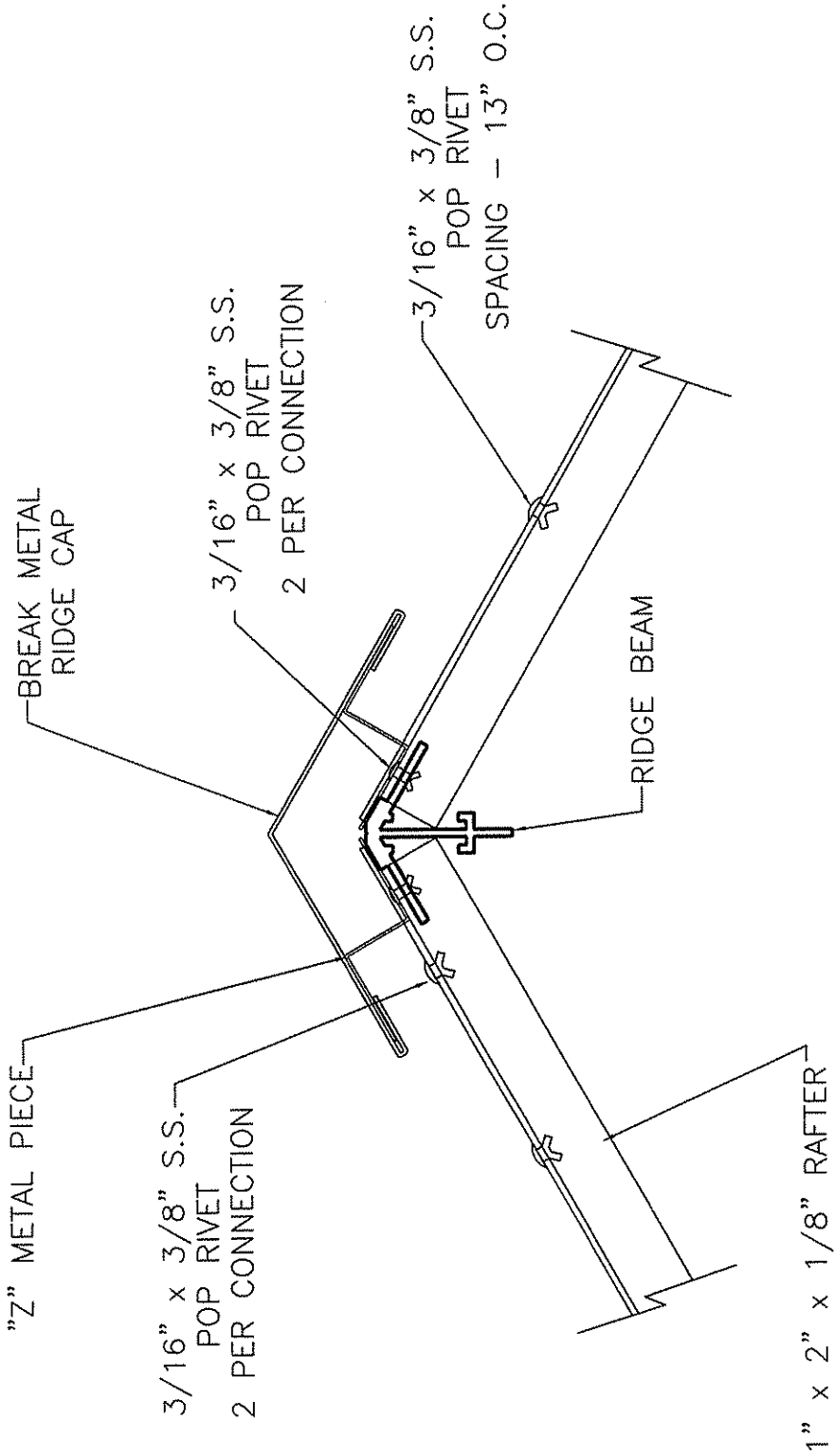

BRASCO INTERNATIONAL, INC.

1000 MT. ELLIOTT
DETROIT, MICHIGAN 48207
1-800-893-3665 WWW.BRASCO.COM

CUSTOMER

PROJECT SLIMLINE SERIES

MODEL STANDING SEAM HIP ROOF DETAIL

DRAWN BY DATE SHEET

APPROVED BY DATE
SCALE NONE REV.

THIS DRAWING IS PROPRIETARY AND IS FOR THE SOLE USE OF
OUR CUSTOMERS AND MAY NOT BE REPRODUCED OR COPIED
WITHOUT WRITTEN PERMISSION FROM BRASCO INTERNATIONAL

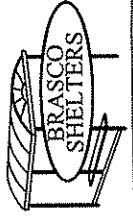

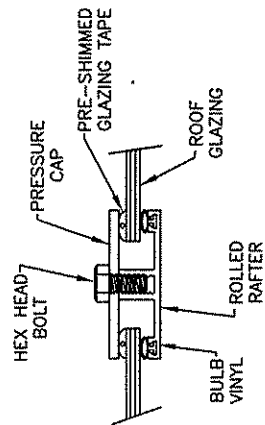
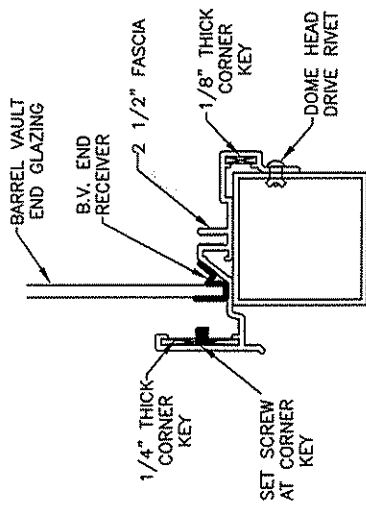
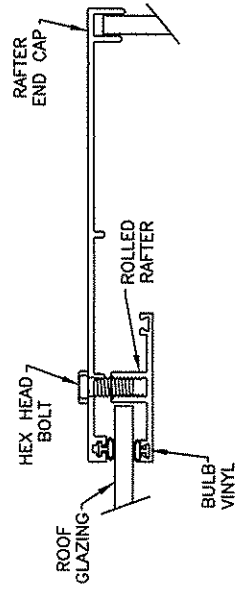
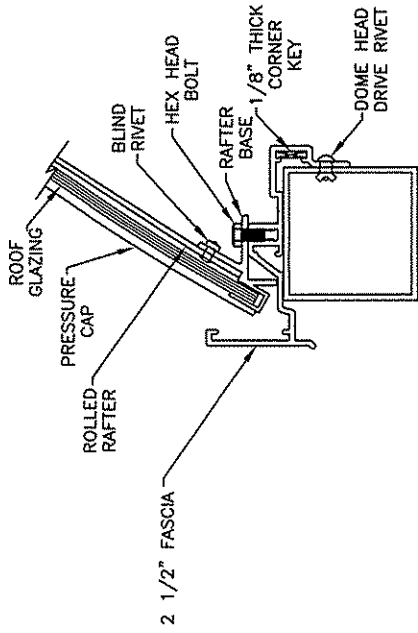

BRASCO INTERNATIONAL, INC.
 1000 MT. ELLIOTT
 DETROIT, MICHIGAN 48207
 1-800-893-3665 WWW.BRASCO.COM

CUSTOMER	DATE	SHEET
PROJECT	DATE	REV.
MODEL	DATE	REV.
DRAWN BY	DATE	REV.
APPROVED BY	DATE	REV.
SCALE	NONE	REV.
THIS DRAWING IS PROPRIETARY AND IS FOR THE SOLE USE OF OUR CUSTOMERS AND MAY NOT BE REPRODUCED OR COPIED WITHOUT WRITTEN PERMISSION FROM BRASCO INTERNATIONAL		



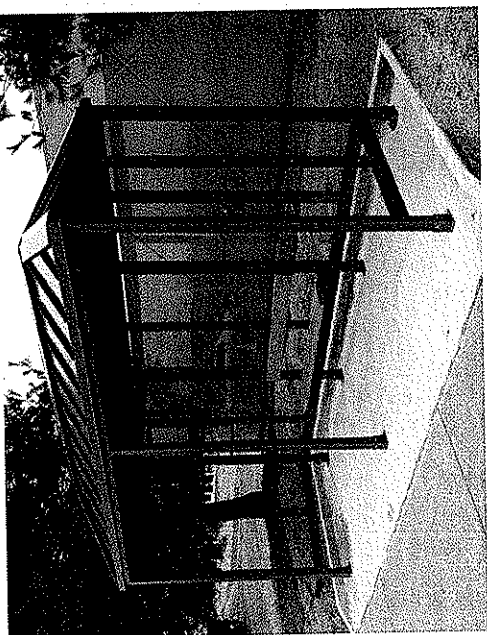
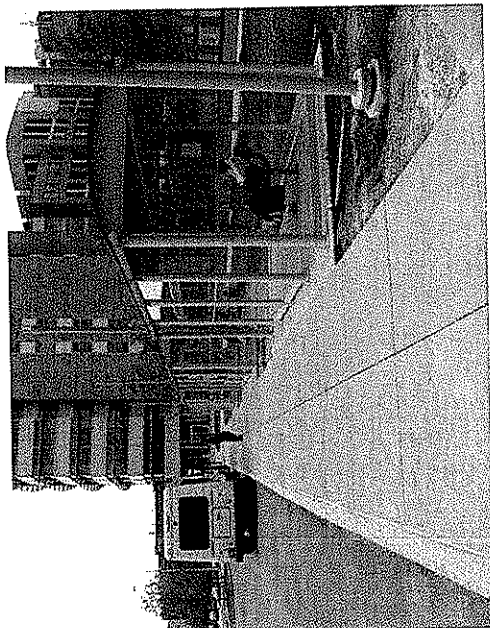
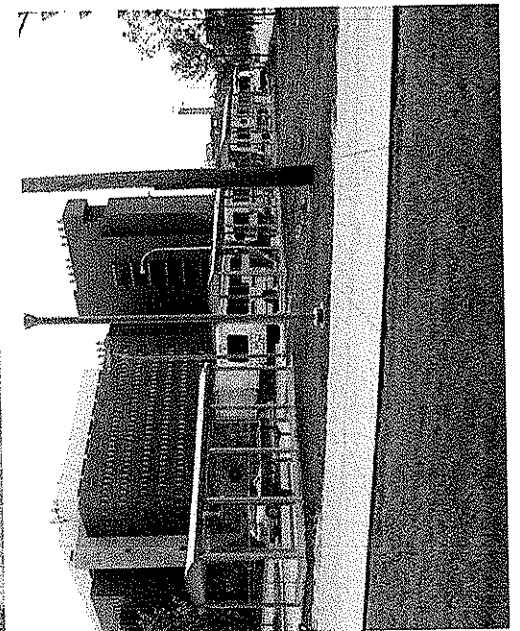
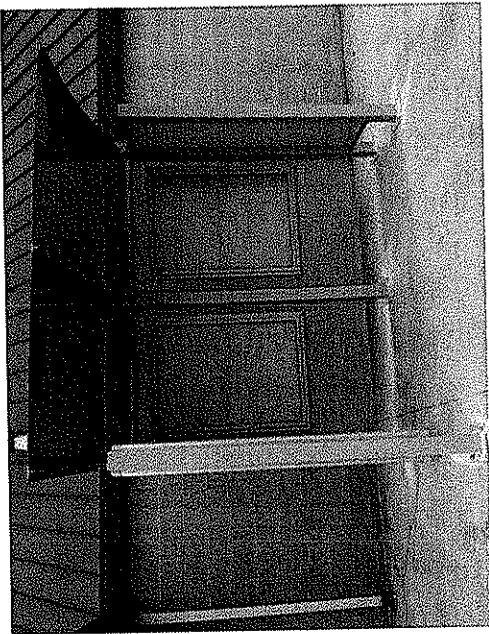
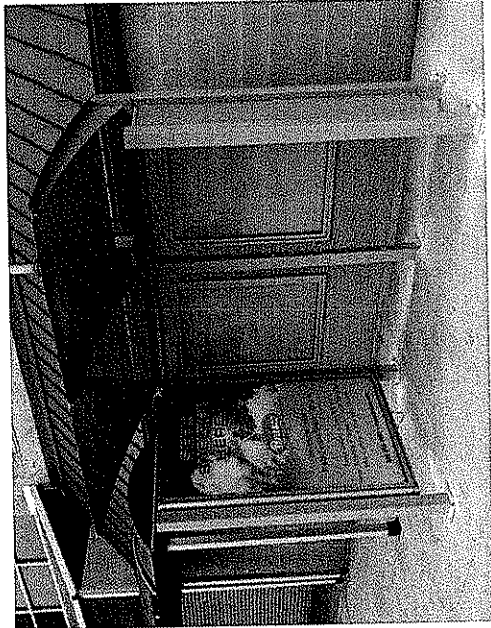
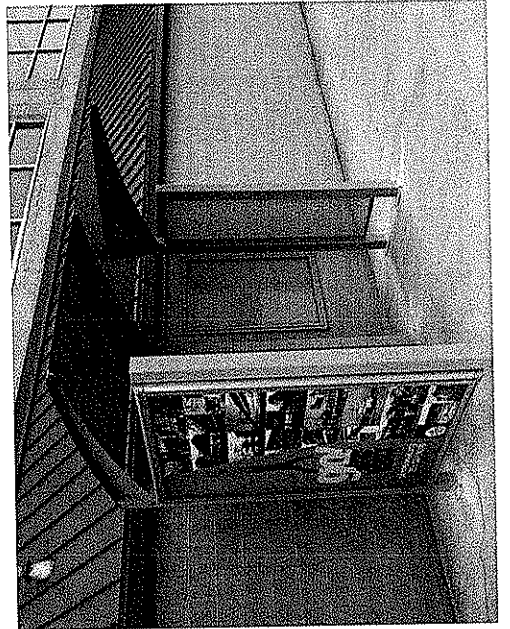
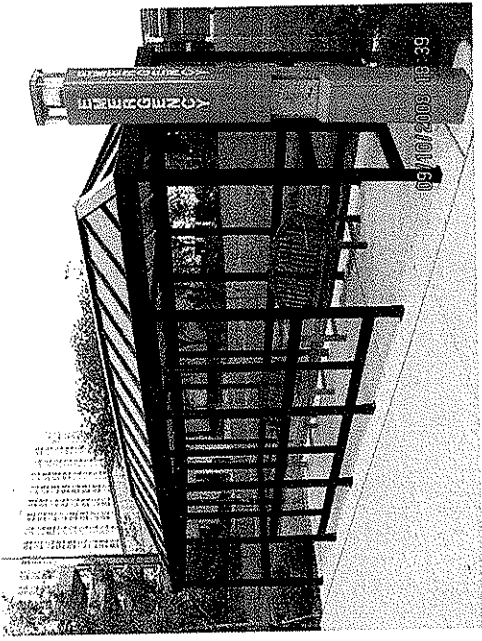
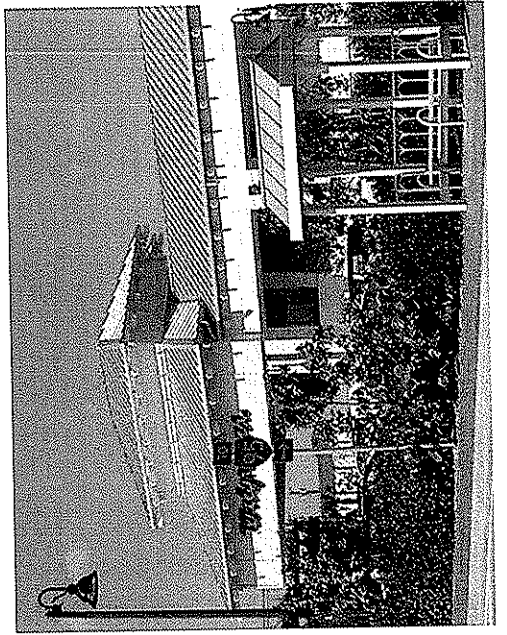

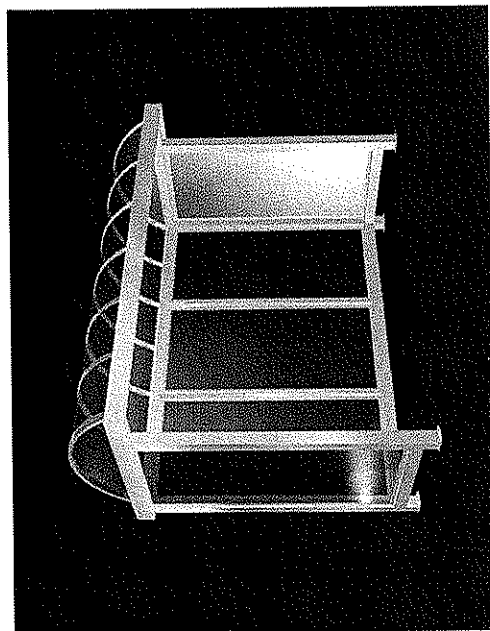
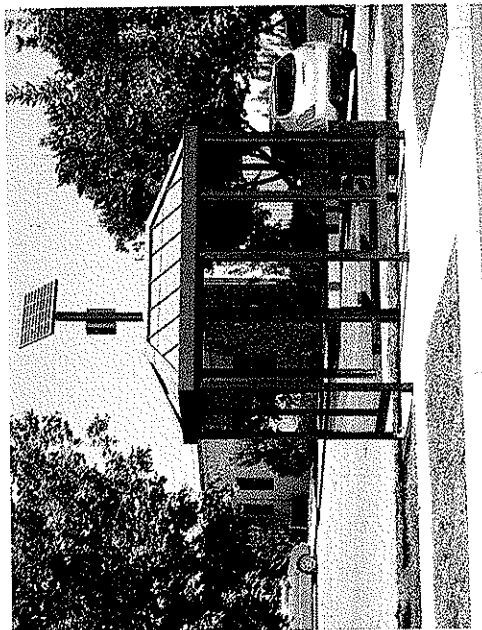
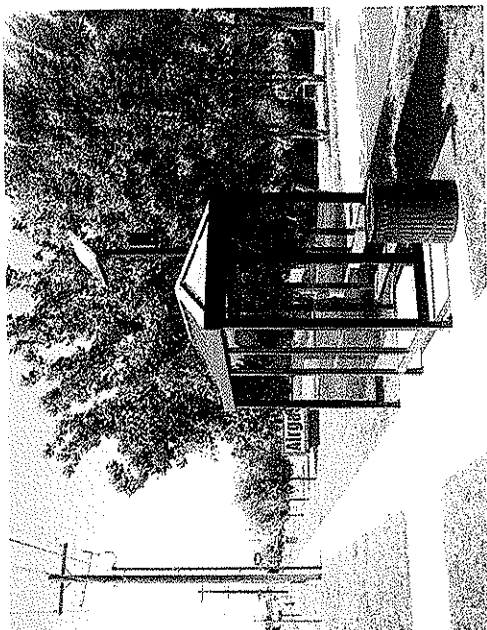
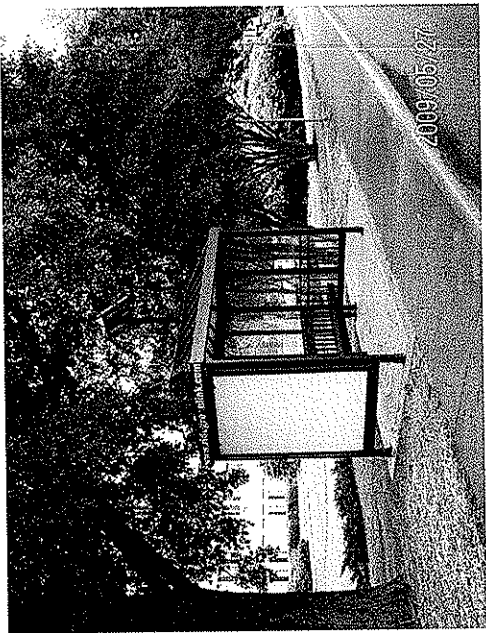

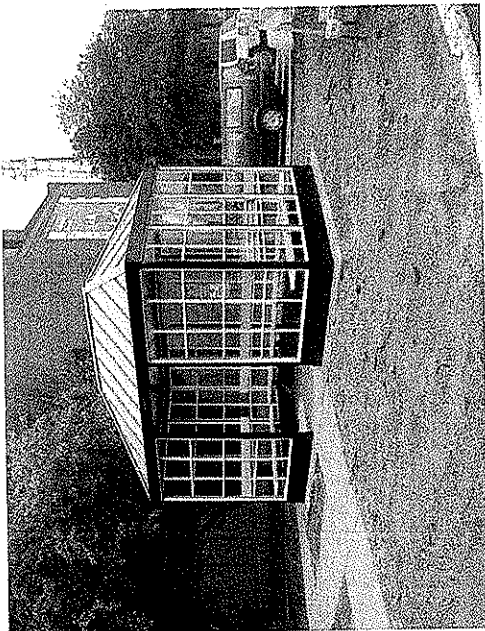
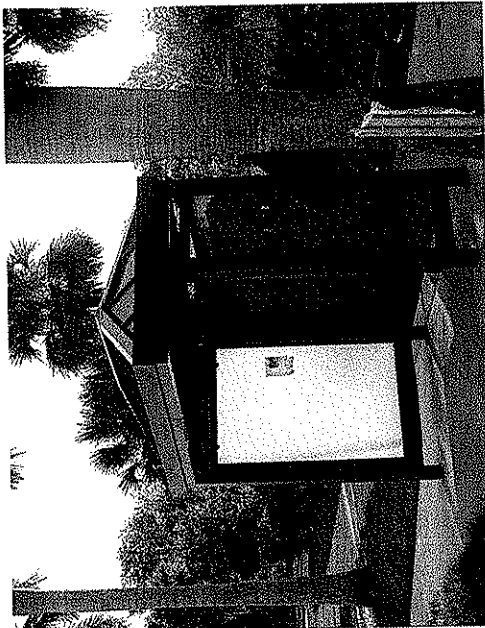
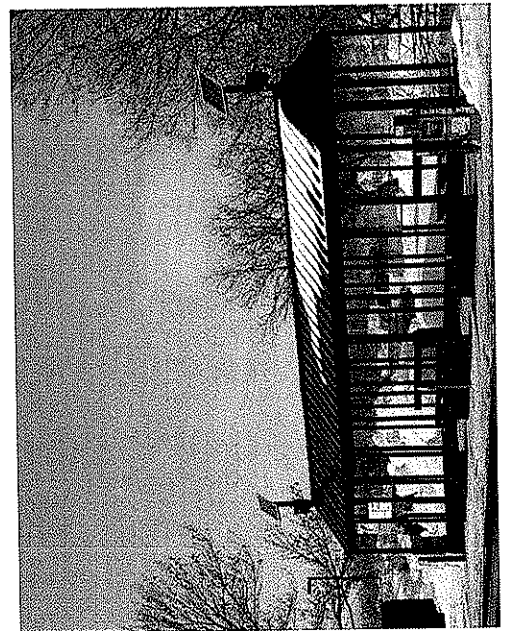
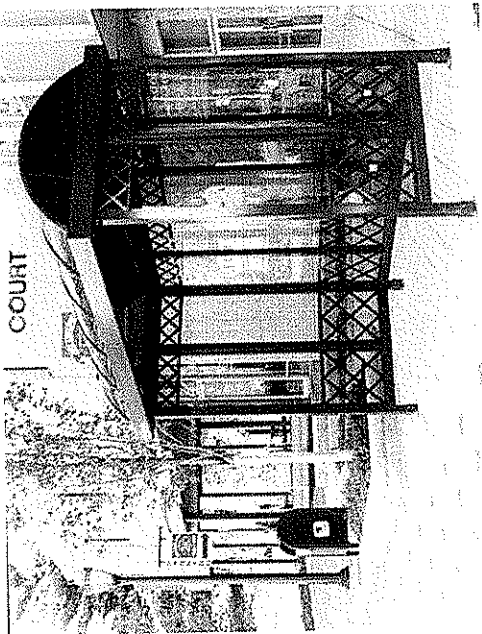
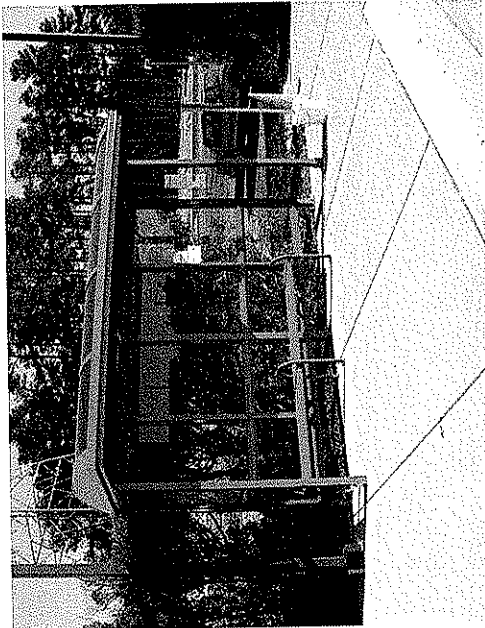
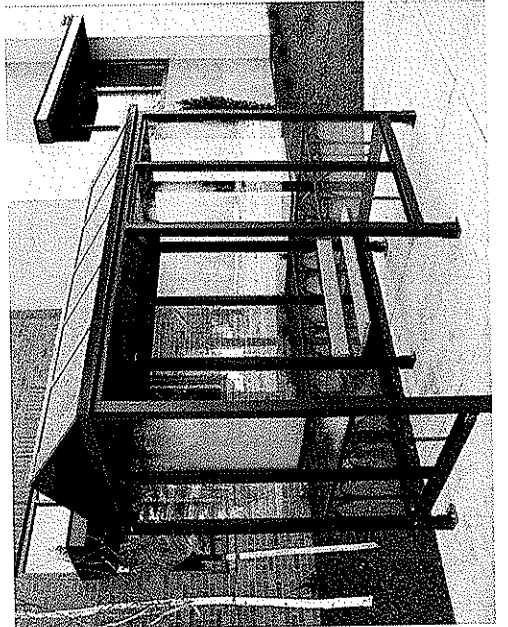
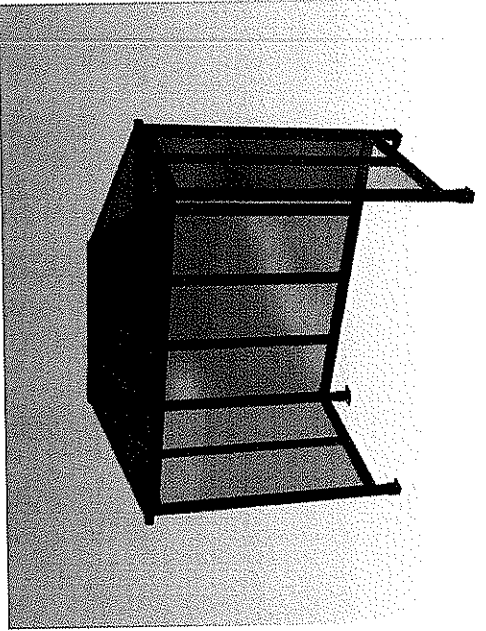
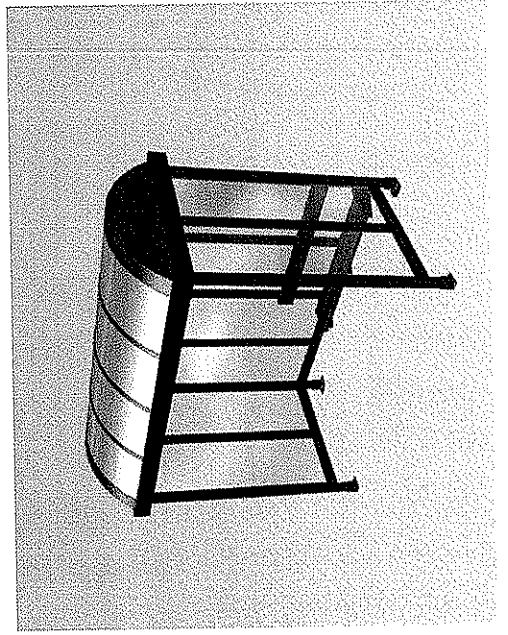

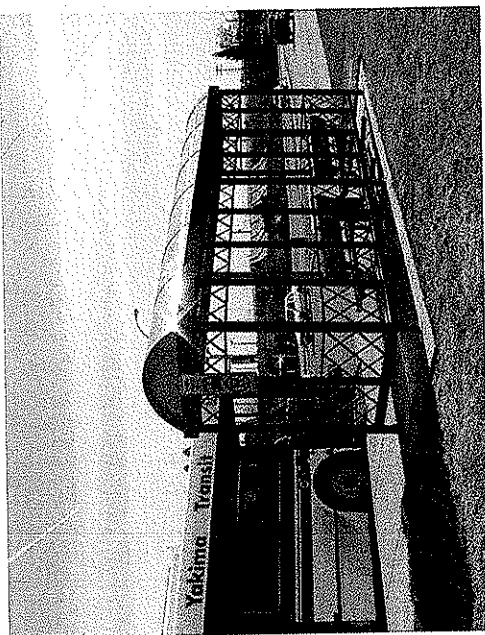
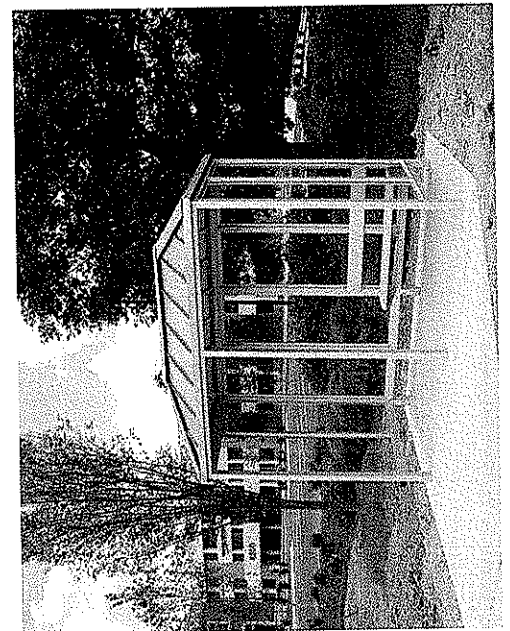
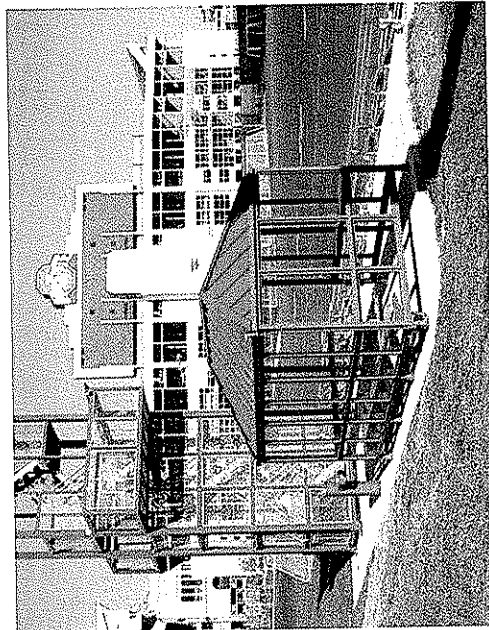
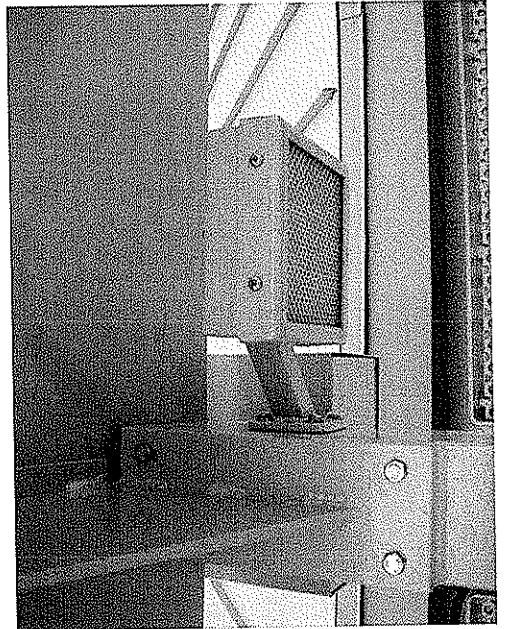
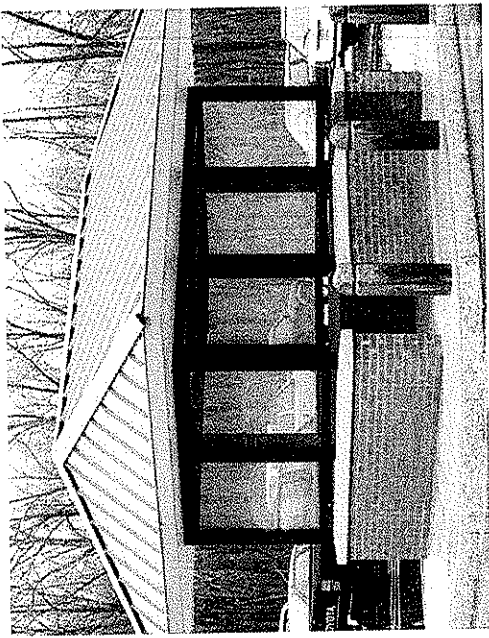
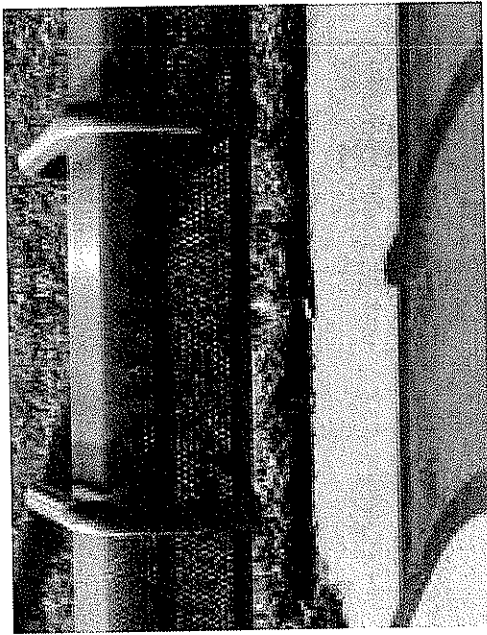
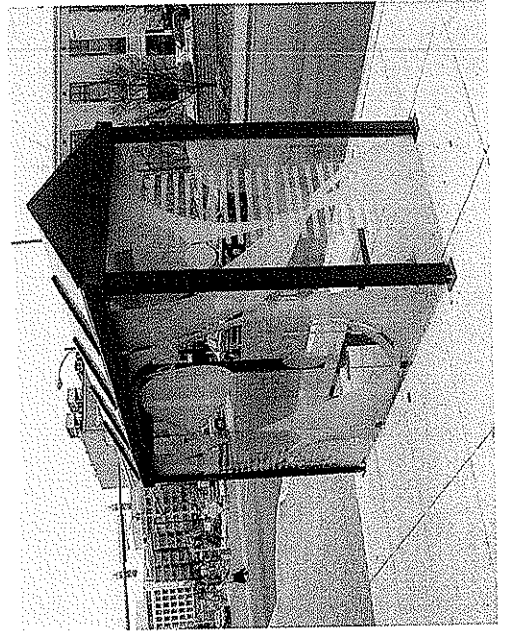

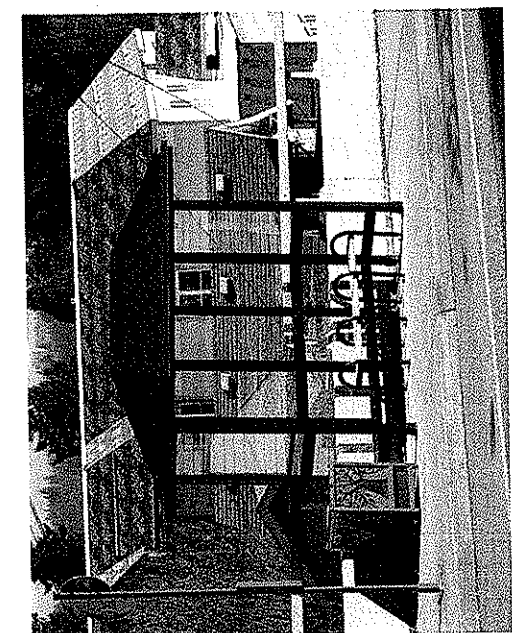
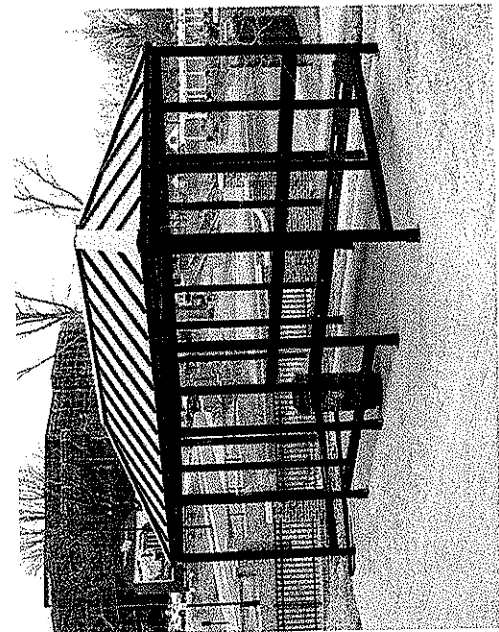
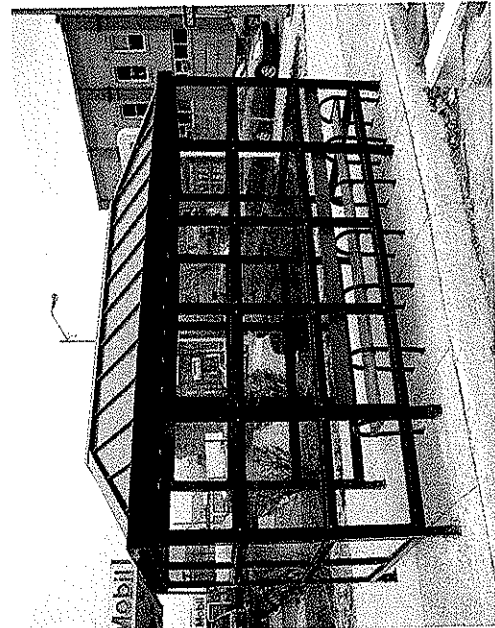
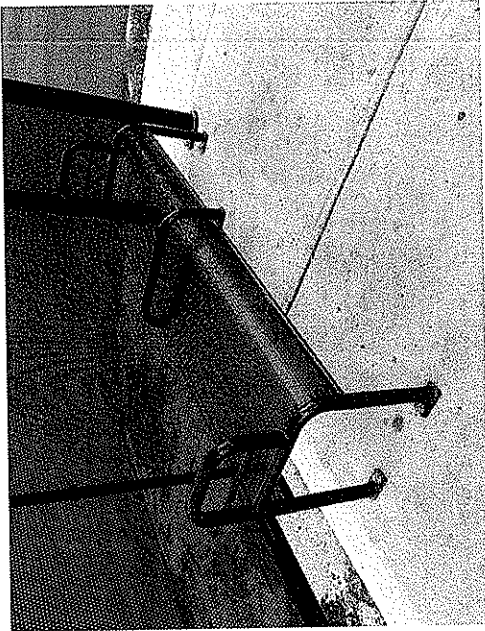
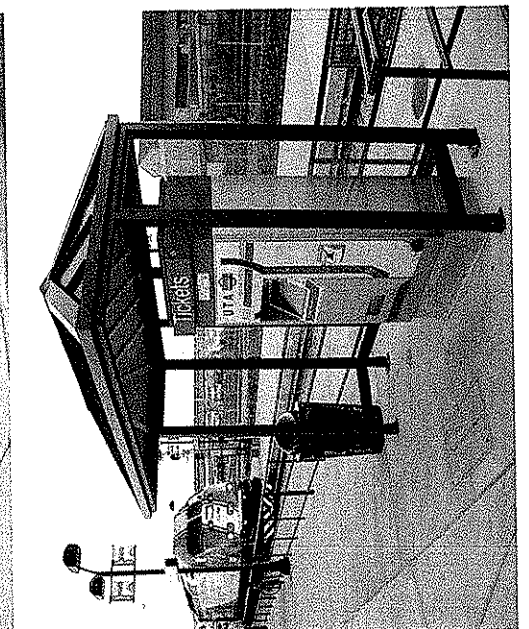
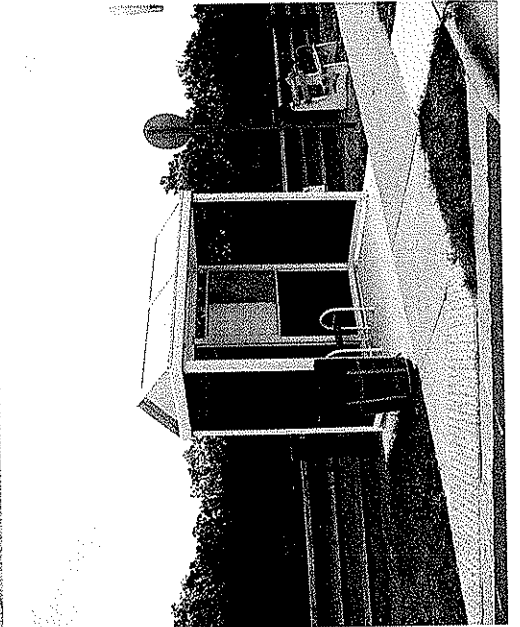
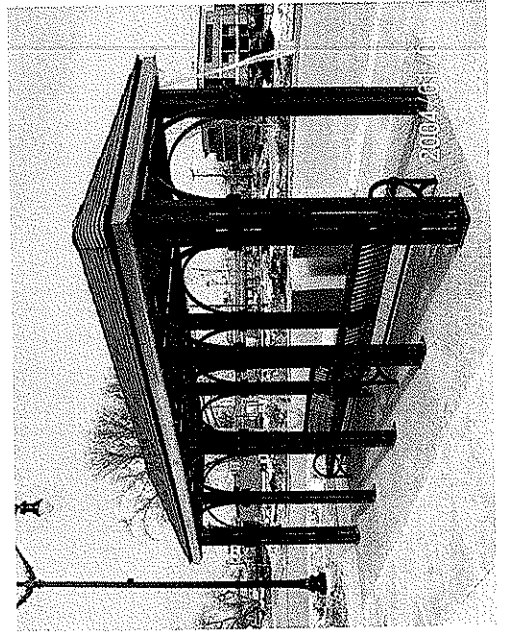

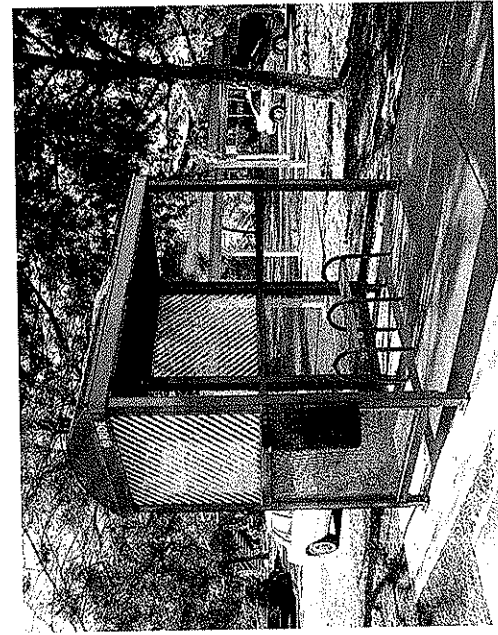
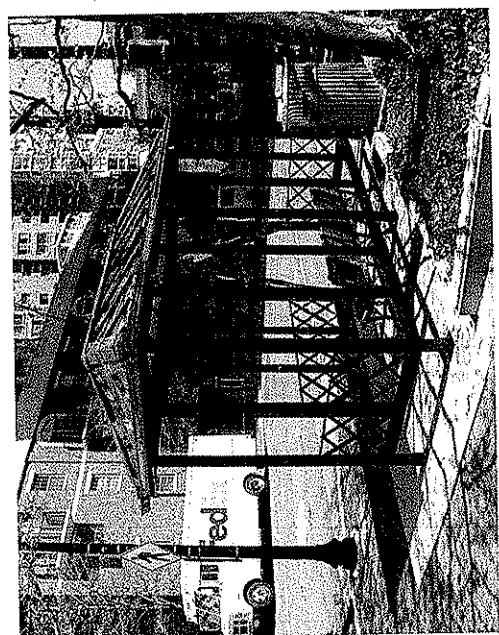
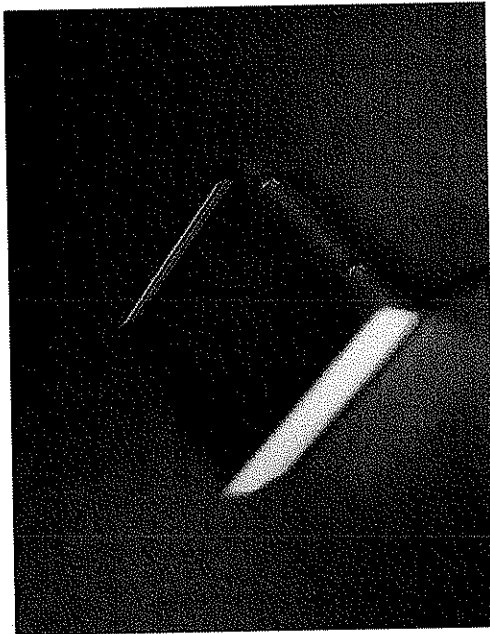
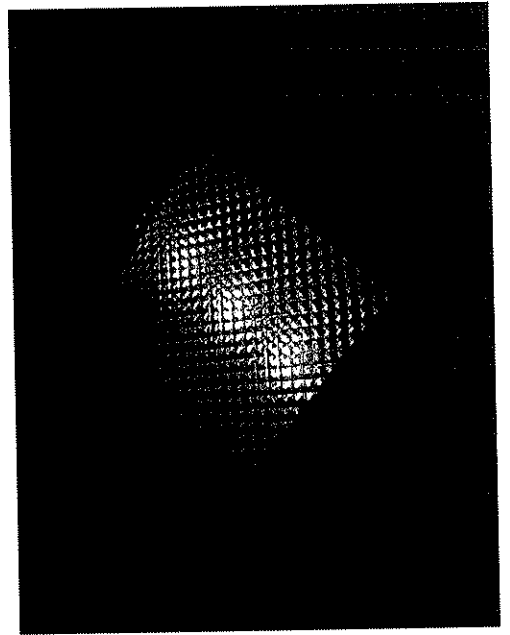
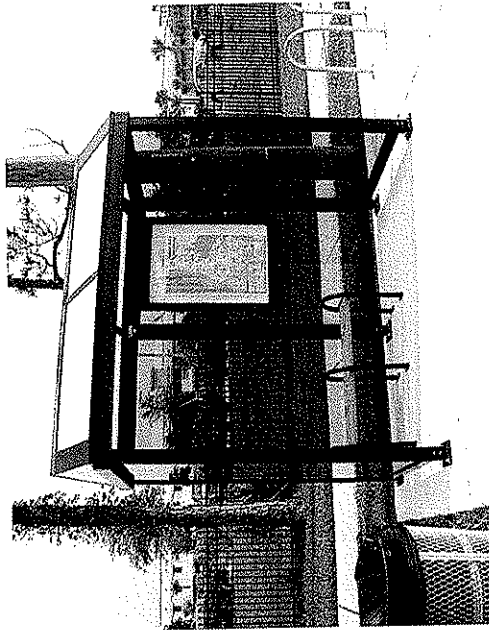
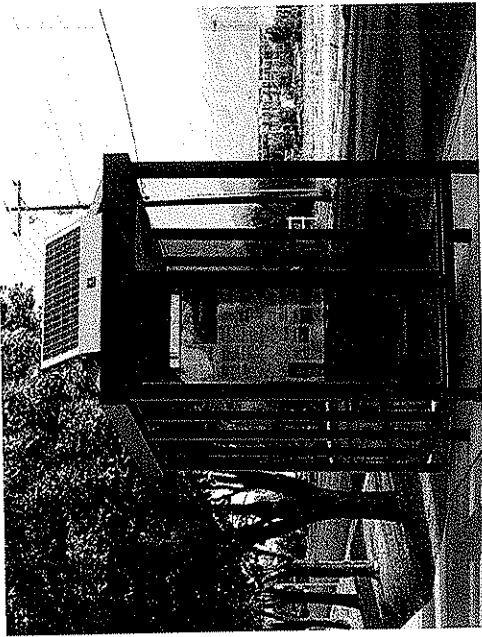

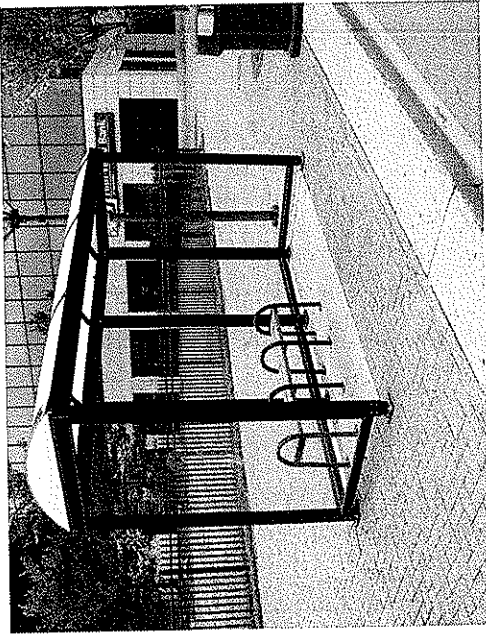
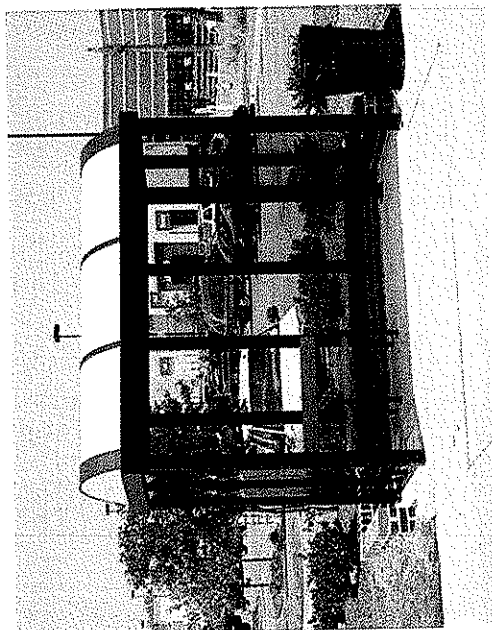
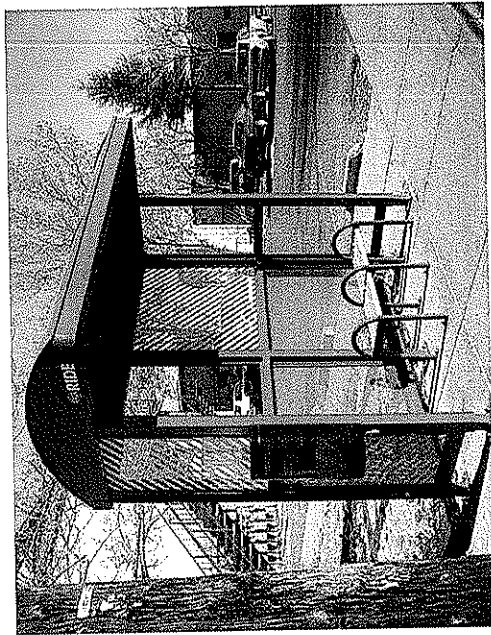
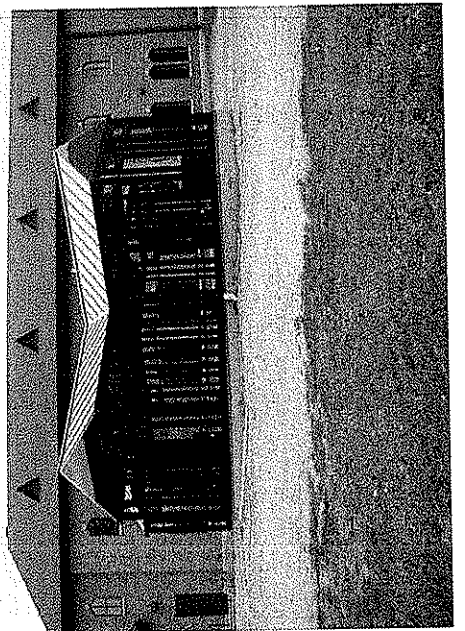
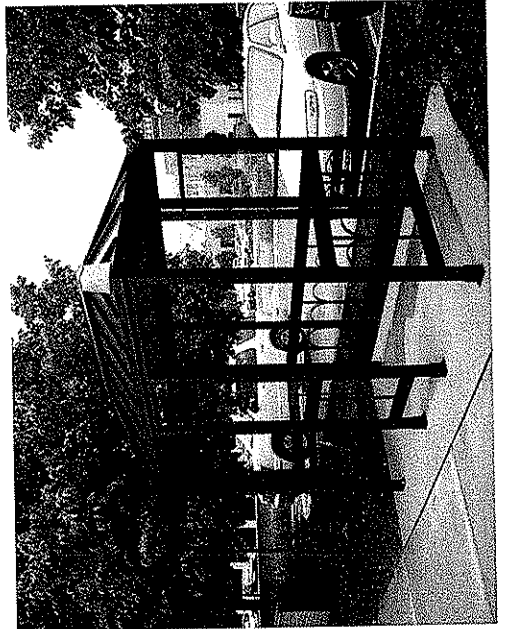

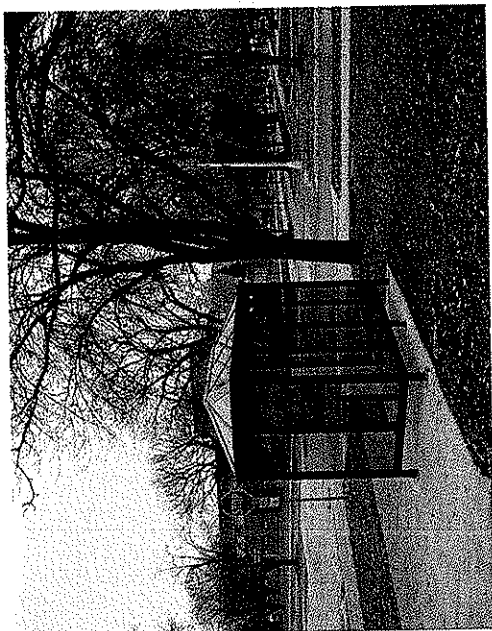
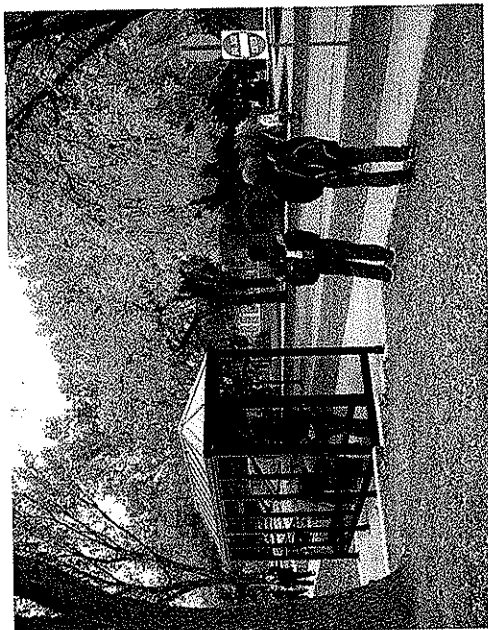
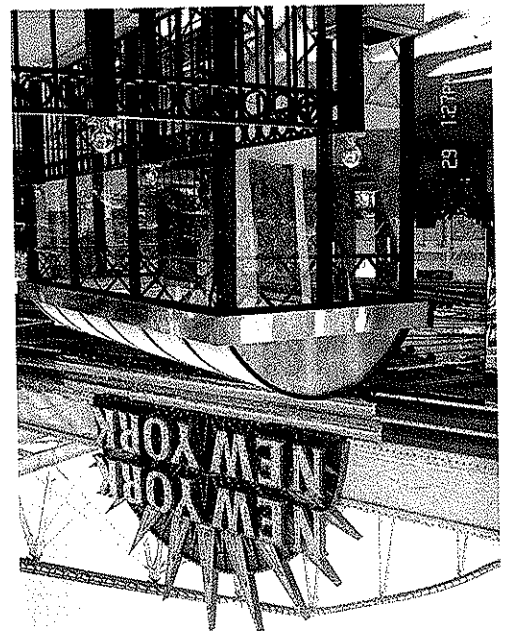
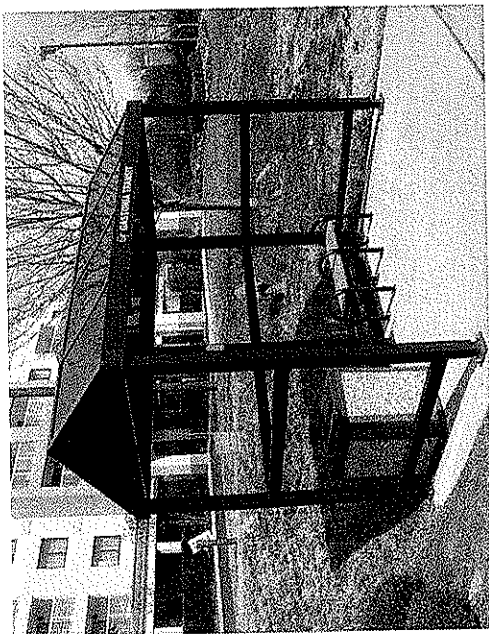
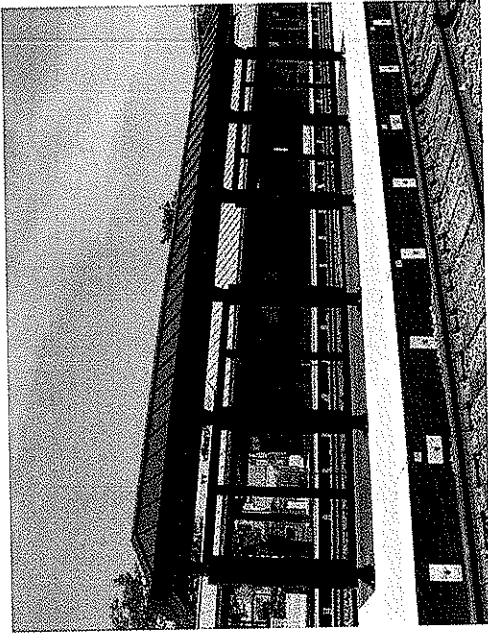
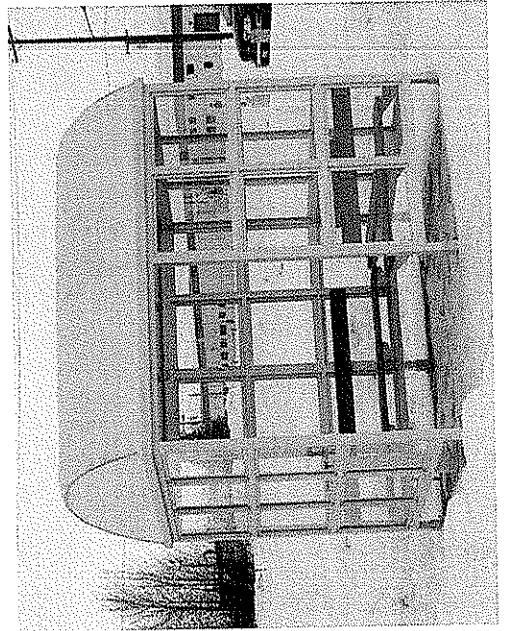

WE WERE GREEN BEFORE GREEN WAS COOL.



Shelters with illumination powered by the sun...

Brasco's solar-powered LED lighting helps to preserve the environment while avoiding the difficulty and expense of connecting to the power grid. Our lighting has been specially designed to meet the highest standards of illumination, ensuring safety and security in our shelters.

- **Cost-effective** • **Easy to install** • **Durable**
- **Reliable** • **Industry-leading warranty**
- **Maintenance-free Safe GEL Batteries**
- **Uniform light pattern** • **Lights on cloudy days**
- **Self-contained solution**

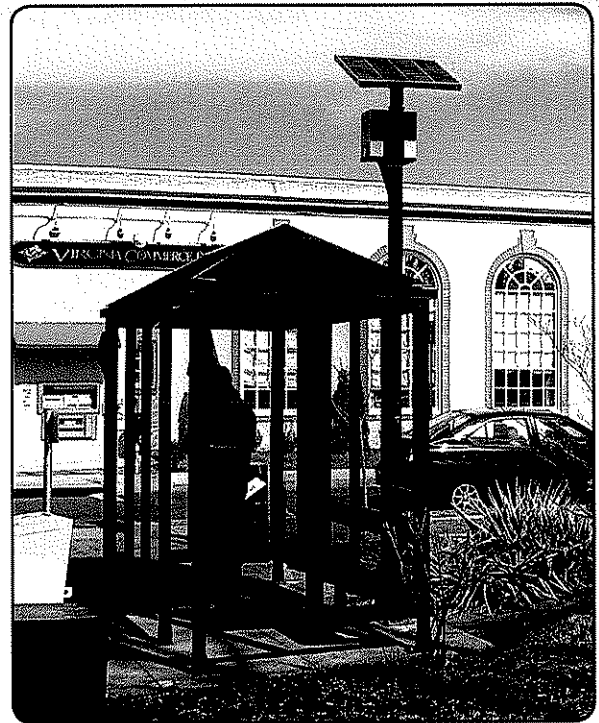

BRASCO INTERNATIONAL, INC.

1000 Mt. Elliott • Detroit, MI 48207
Phone: 800-893-3665 • Fax: 313-393-0499
www.brasco.com

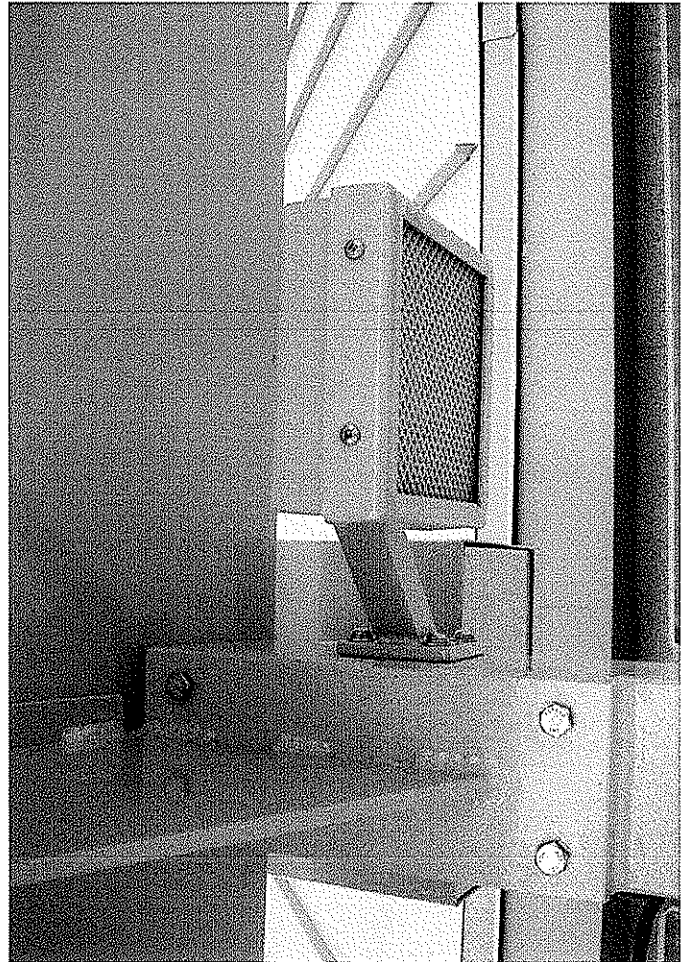
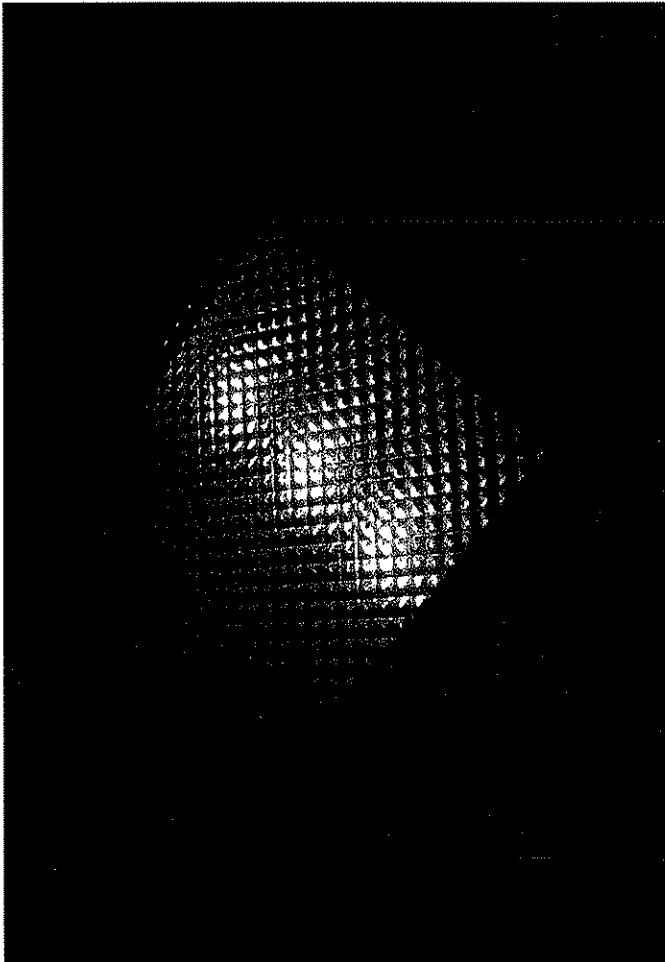
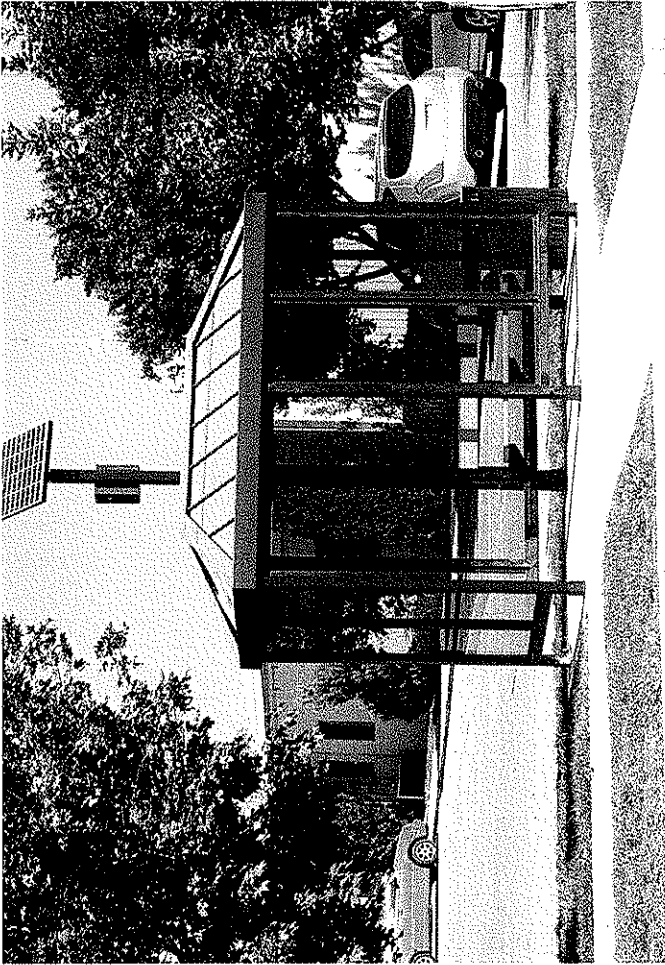



DESCRIPTION

Components of the Brasco Solar General Illumination Package are shown on the following pages in Figure 1: Electrical Schematic and Figure 2: Brasco Solar General Illumination Package Exploded Parts Drawing. Refer to the Parts List on page 5 for a complete listing of hardware for each system.

UNPACKING AND INSPECTION

The Brasco Solar General Illumination Package is shipped as a complete kit. Prior to assembly, remove the entire contents of the kit from the packaging and check the contents of the kit against Figure 2: Brasco Solar General Illumination Package Exploded Parts Drawing and the Parts List (Table 1) on pages 5 and 6.



Please call Brasco Customer Service at +1.800.893.3665 if any components or hardware are missing.



ELECTRICAL SCHEMATIC

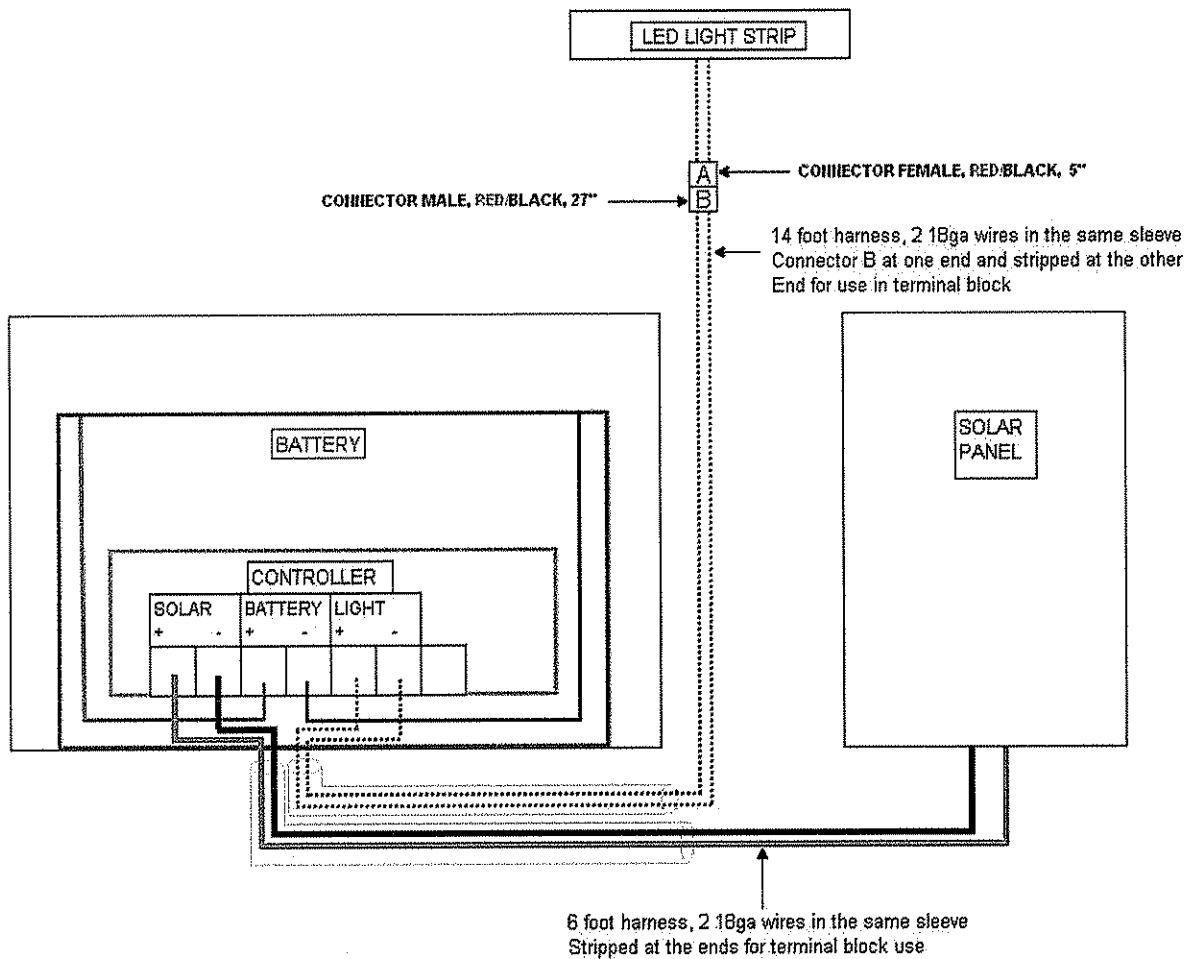
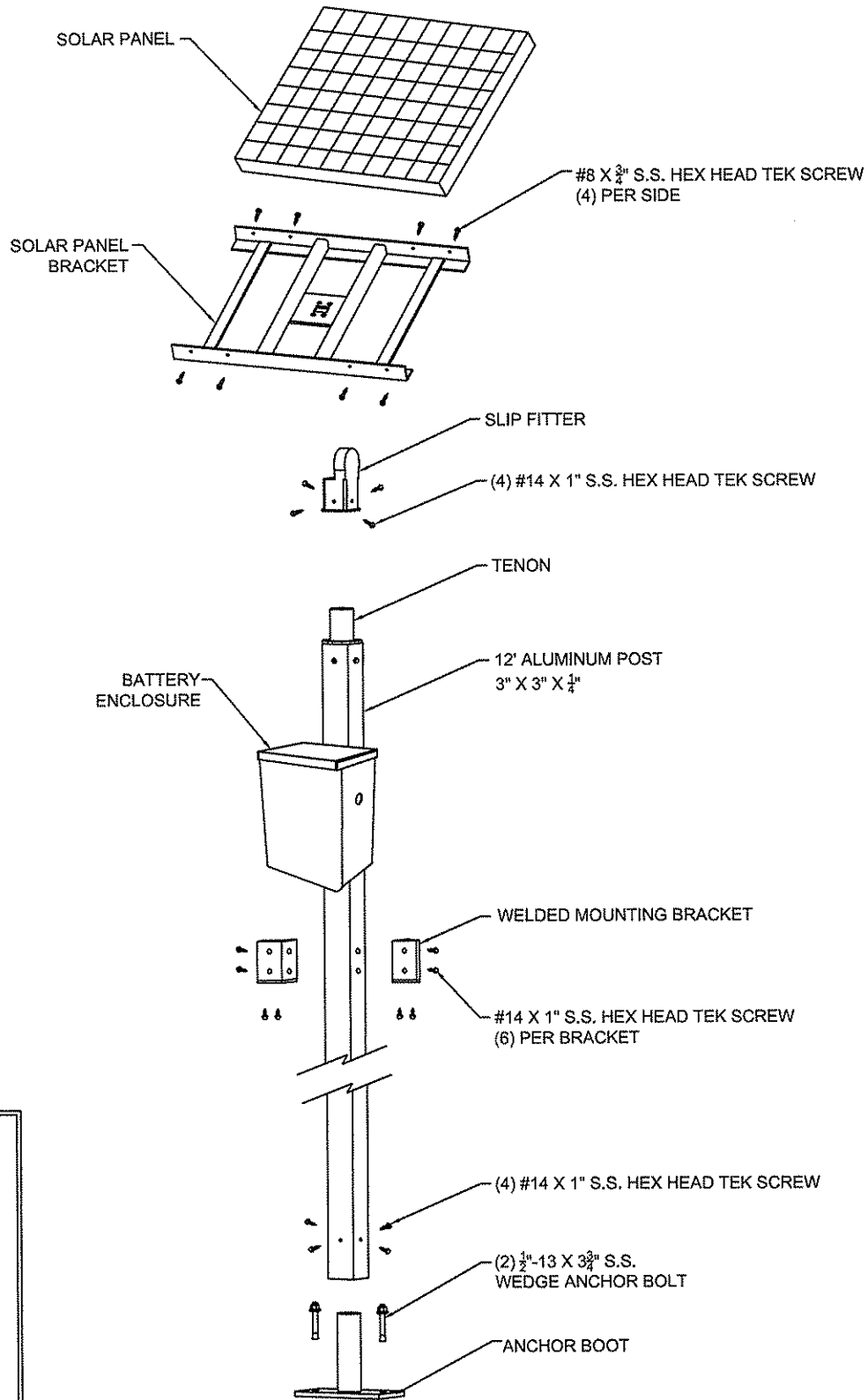

Figure 2: Electrical Schematic

Roof Mounted Design Also Available *SJ*



TOOLS REQUIRED:

- CORDLESS DRILL
- $\frac{1}{4}$ " X 6" LG. DRILL BIT
- 1" HOLE SAW
- #11 DRILL BIT (OPTIONAL)
- HAMMER
- ALLEN WRENCH SET
- SPANNER BIT
- $\frac{7}{16}$ " WRENCH OR SOCKET
- $\frac{3}{8}$ " DRIVE SOCKET
- HAMMER DRILL
- $\frac{1}{2}$ " MASONRY BIT

BRASCO INTERNATIONAL, INC.

1000 MT. ELLIOTT
 DETROIT, MICHIGAN 48207
 1-800-893-3665 WWW.BRASCO.COM

MODEL	SOLAR PACKAGE INSTALL EXPLODED VIEW	
DRAWN BY	SJT	DATE 4-20-09
SCALE	NONE	SHEET 1

THIS DRAWING IS PROPRIETARY AND IS FOR THE SOLE USE OF OUR CUSTOMERS AND MAY NOT BE REPRODUCED OR COPIED WITHOUT WRITTEN PERMISSION FROM BRASCO INTERNATIONAL.



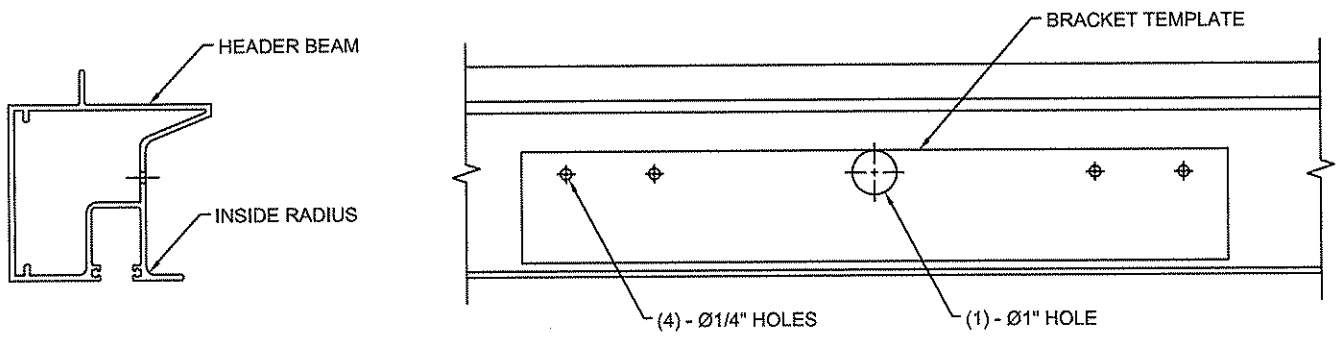

- 1) LOCATE WHERE LIGHT WILL BE MOUNTED ON INSIDE OF HEADER BEAM.
(NOTE: LIGHT CANNOT BE MOUNTED ABOVE COLUMN)
- 2) PLACE BRACKET TEMPLATE ON INSIDE OF HEADER AT DESIRED LOCATION AND TRANSFER MOUNTING HOLE PATTERN TO HEADER.
(NOTE: BOTTOM OF BRACKET TEMPLATE SHOULD BE PLACED AT TOP OF INSIDE RADIUS ON HEADER AND MUST BE LEVEL)
- 3) DRILL (4) - $\frac{1}{4}$ " HOLES FOR DRIVE RIVETS AND (1) - $\varnothing 1$ " HOLE FOR ELECTRICAL CONNECTION.
(NOTE: $\varnothing 1$ " HOLE WILL BE DRILLED THRU OUTSIDE OF HEADER AT SOLAR POST LOCATION, MUST BE WITHIN 5' OF LIGHT FIXTURE)

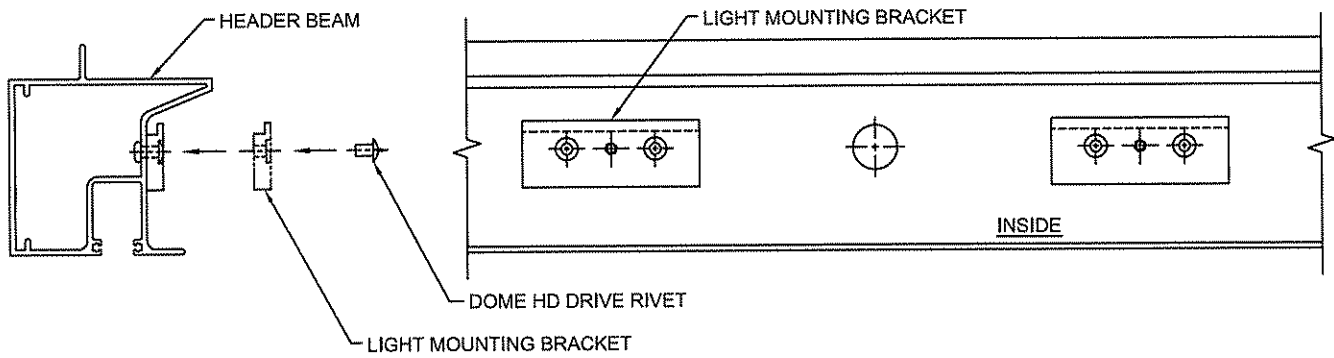

- 4) MOUNT (2) - LIGHT MOUNTING BRACKETS WITH (2) - $\frac{1}{4}$ " X $\frac{3}{8}$ " DOME HEAD DRIVE RIVETS PER BRACKET

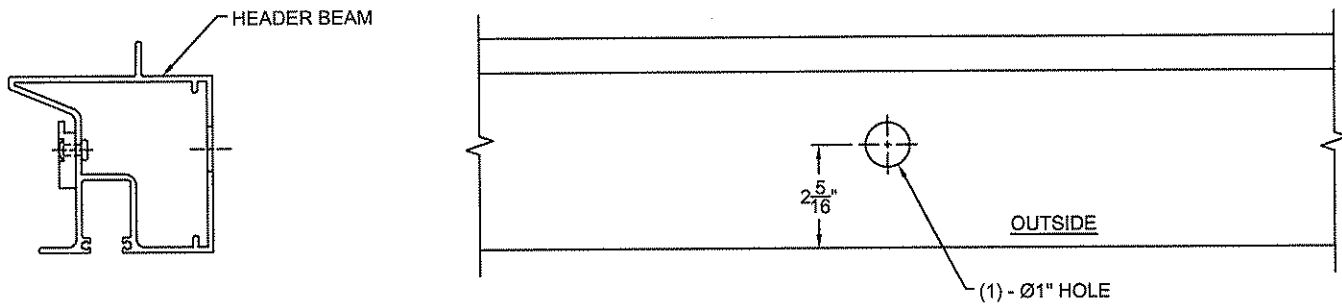

- 5) LOCATE WHERE SOLAR POST WILL BE MOUNTED AND DRILL (1) - $\varnothing 1$ " HOLE THRU THE OUTSIDE OF THE HEADER.
(NOTE: IF POSSIBLE, DRILL HOLE IN LINE WITH HOLE ON INTERIOR OF SHELTER)

BRASCO INTERNATIONAL, INC.

1000 MT. ELLIOTT
DETROIT, MICHIGAN 48207

1-800-893-3665

WWW.BRASCO.COM

MODEL SOLAR PACKAGE INSTALL EXPLODED VIEW

DRAWN BY SJT DATE 4-20-09

SCALE NONE SHEET 2

THIS DRAWING IS PROPRIETARY AND IS FOR THE SOLE USE OF OUR CUSTOMERS AND MAY NOT BE REPRODUCED OR COPIED WITHOUT WRITTEN PERMISSION FROM BRASCO INTERNATIONAL.



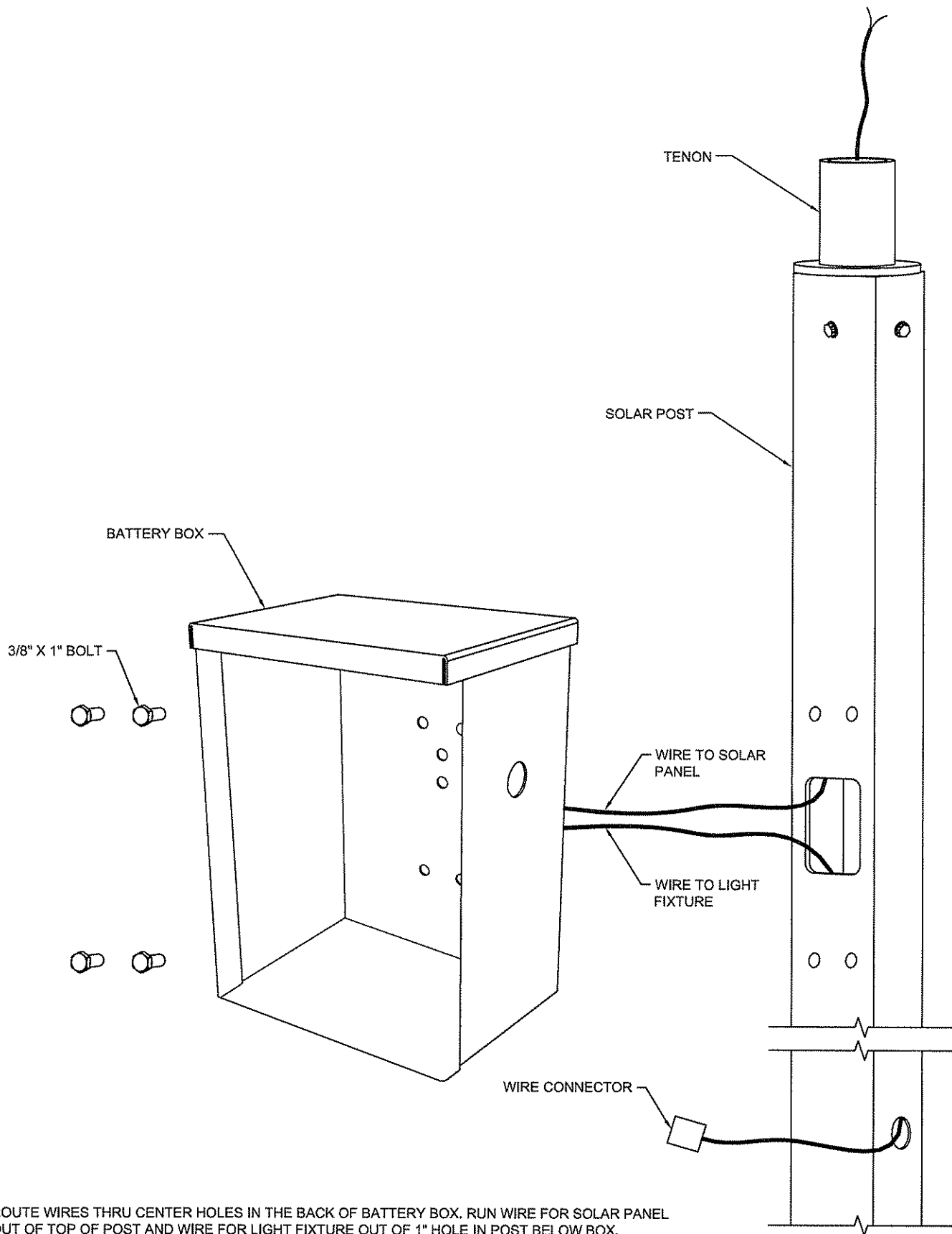

6) ROUTE WIRES THRU CENTER HOLES IN THE BACK OF BATTERY BOX. RUN WIRE FOR SOLAR PANEL OUT OF TOP OF POST AND WIRE FOR LIGHT FIXTURE OUT OF 1" HOLE IN POST BELOW BOX.
 7) MOUNT BOX TO SOLAR POST WITH (4) 3/8" X 1" BOLT.

BRASCO INTERNATIONAL, INC.
 1000 MT. ELLIOTT
 DETROIT, MICHIGAN 48207
 1-800-893-3665 WWW.BRASCO.COM

MODEL SOLAR PACKAGE INSTALL EXPLODED VIEW

DRAWN BY SJT DATE 4-20-09

SCALE NONE SHEET 3

THIS DRAWING IS PROPRIETARY AND IS FOR THE SOLE USE OF OUR CUSTOMERS AND MAY NOT BE REPRODUCED OR COPIED WITHOUT WRITTEN PERMISSION FROM BRASCO INTERNATIONAL.



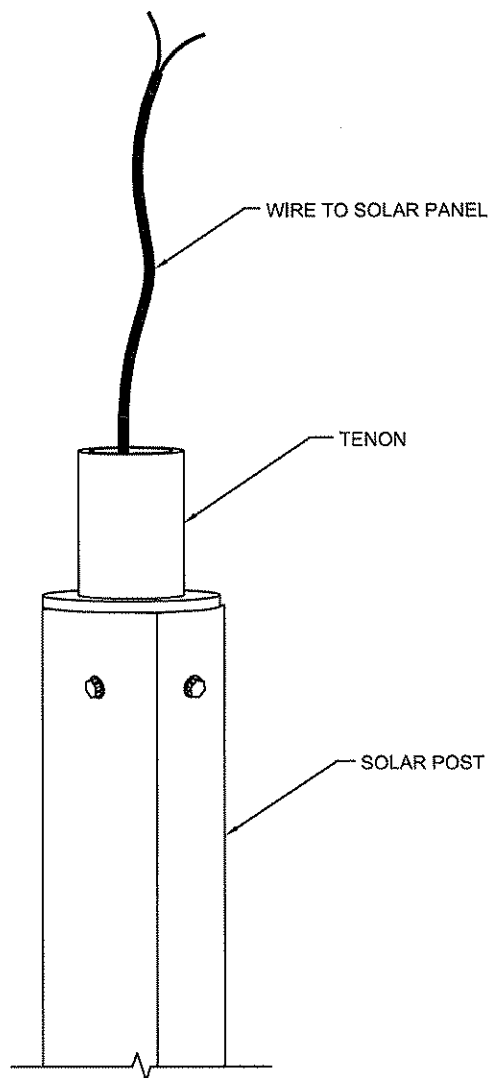
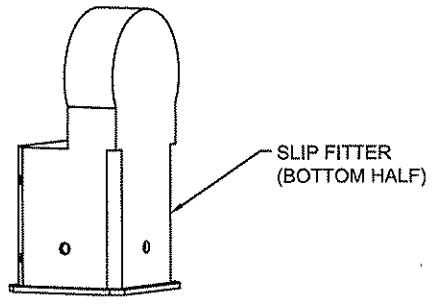

8) ROUTE WIRE THRU BOTTOM HALF OF SLIP FITTER AND SLIDE SLIP FITTER OVER TENON. (DO NOT ATTACH YET)

BRASCO INTERNATIONAL, INC.
 1000 MT. ELLIOTT
 DETROIT, MICHIGAN 48207
 1-800-893-3665 WWW.BRASCO.COM

MODEL	SOLAR PACKAGE INSTALL EXPLODED VIEW	
DRAWN BY	SJT	DATE 4-20-09
SCALE	NONE	SHEET 4
THIS DRAWING IS PROPRIETARY AND IS FOR THE SOLE USE OF OUR CUSTOMERS AND MAY NOT BE REPRODUCED OR COPIED WITHOUT WRITTEN PERMISSION FROM BRASCO INTERNATIONAL.		



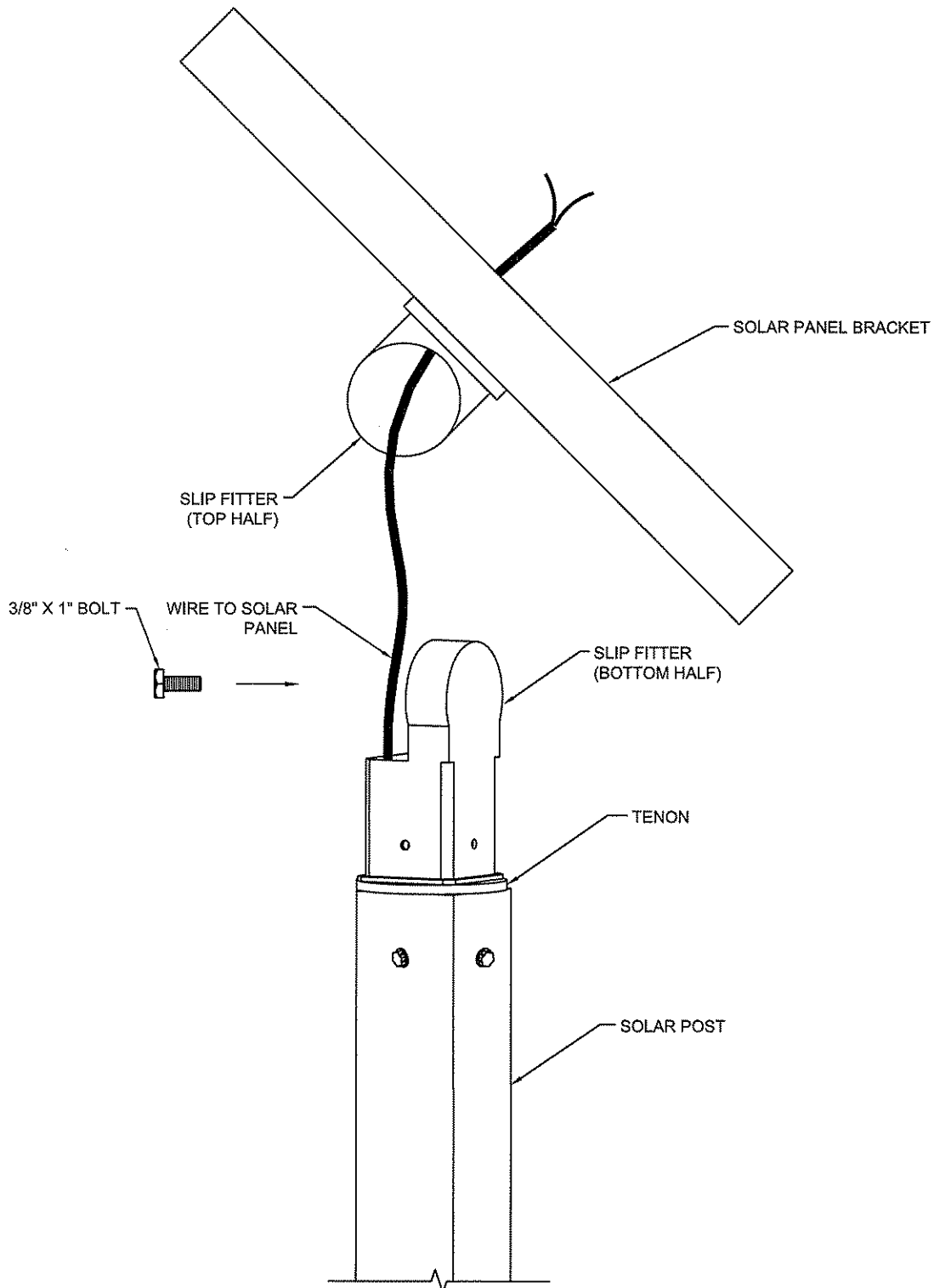

9) ROUTE WIRE THRU TOP HALF OF SLIP FITTER AND SOLAR PANEL BRACKET AND ATTACH SLIP FITTER HALVES TOGETHER AT A 45° ANGLE WITH (1) 3/8"-16 X 1" S.S. HEX HD BOLT.

BRASCO INTERNATIONAL, INC.
 1000 MT. ELLIOTT
 DETROIT, MICHIGAN 48207
 1-800-893-3665 WWW.BRASCO.COM

MODEL	SOLAR PACKAGE INSTALL EXPLODED VIEW	
DRAWN BY	SJT	DATE 4-20-09
SCALE	NONE	SHEET 5

THIS DRAWING IS PROPRIETARY AND IS FOR THE SOLE USE OF OUR CUSTOMERS AND MAY NOT BE REPRODUCED OR COPIED WITHOUT WRITTEN PERMISSION FROM BRASCO INTERNATIONAL.



SOLAR PANEL

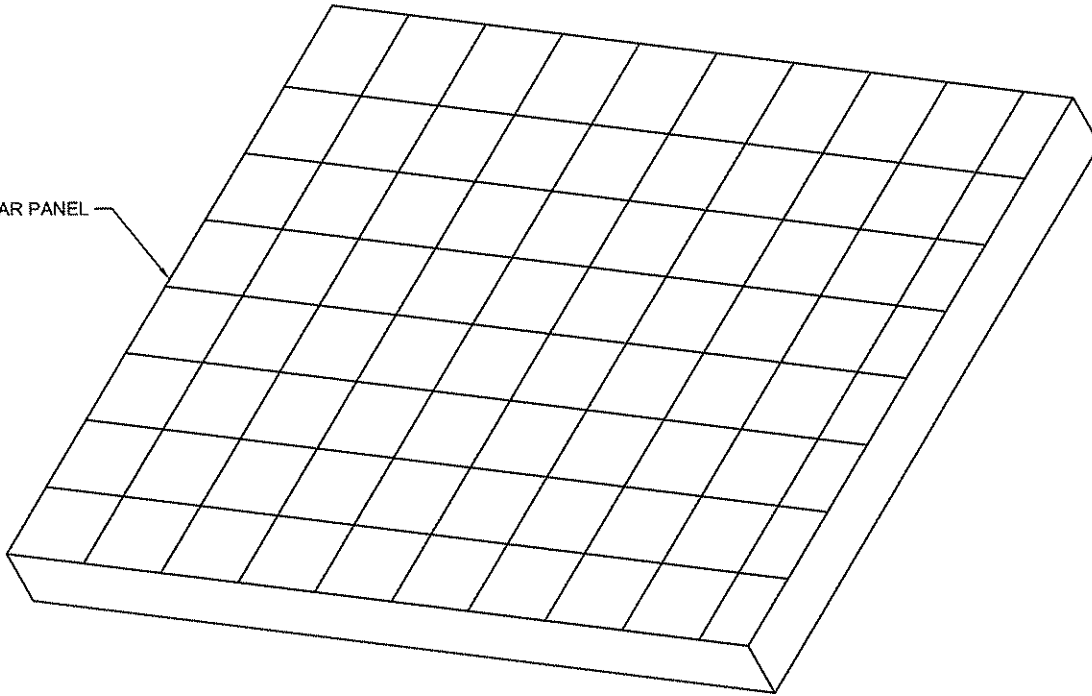

SOLAR PANEL BRACKET

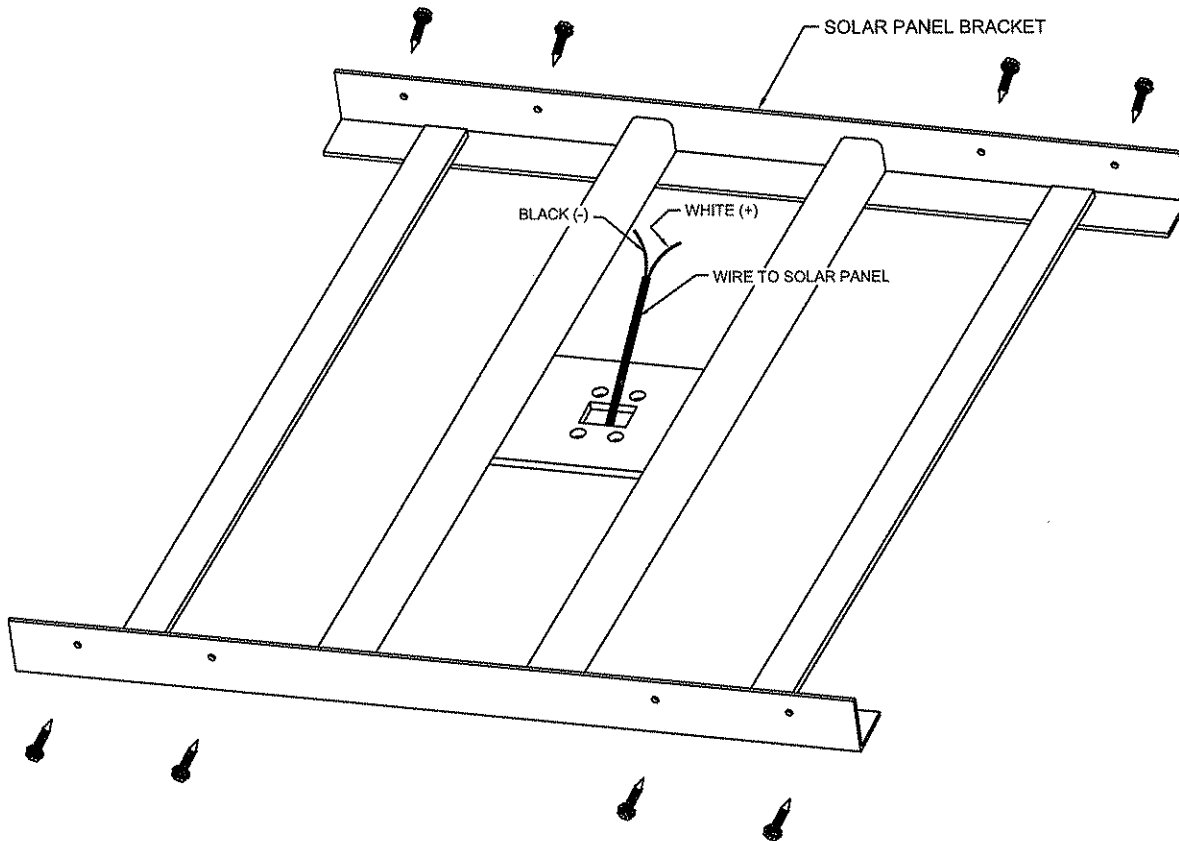

- 10) ATTACH WIRES TO SOLAR PANEL. BLACK WIRE TO NEGATIVE (-) TERMINAL AND WHITE WIRE TO POSITIVE (+) TERMINAL.
- 11) MOUNT SOLAR PANEL TO SOLAR PANEL BRACKET WITH (8) - #8 X $\frac{3}{4}$ " S.S. HEX HD TEK SCREW.

BRASCO INTERNATIONAL, INC.
 1000 MT. ELLIOTT
 DETROIT, MICHIGAN 48207
 1-800-893-3665 WWW.BRASCO.COM

MODEL	SOLAR PACKAGE INSTALL EXPLODED VIEW	
DRAWN BY	SJT	DATE 4-20-09
SCALE	NONE	SHEET 6
THIS DRAWING IS PROPRIETARY AND IS FOR THE SOLE USE OF OUR CUSTOMERS AND MAY NOT BE REPRODUCED OR COPIED WITHOUT WRITTEN PERMISSION FROM BRASCO INTERNATIONAL.		



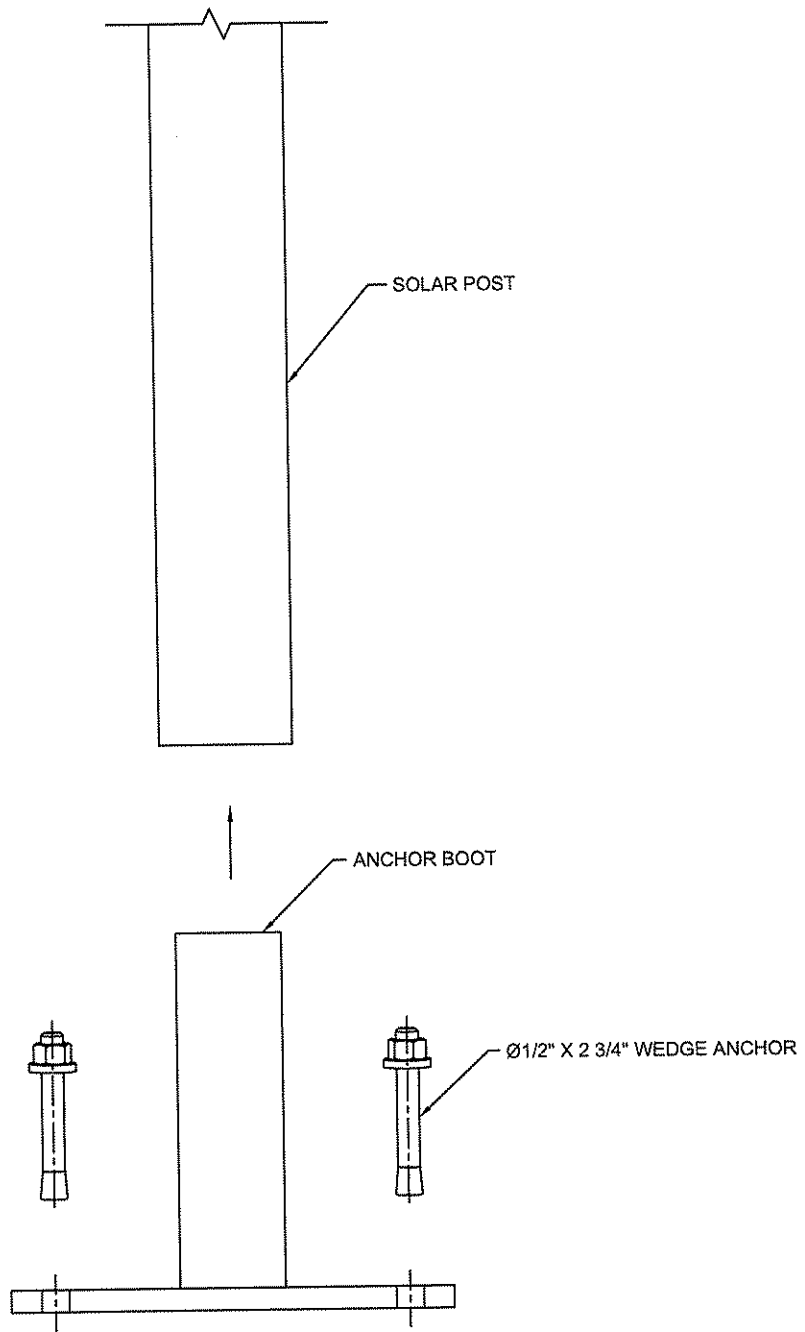

- 12) SLIDE ANCHOR BOOT INTO BOTTOM OF THE SOLAR POST - DO NOT ATTACH.
- 13) STAND SOLAR POST CLOSE TO WHERE IT IS BEING ATTACHED. FEED THE WIRE FOR THE LIGHT THRU THE Ø1" HOLES TO INSIDE OF SHELTER.
- 14) WITH SOLAR POST IN PLACE & PLUM & FLUSH TO THE HEADER, DRILL (2) - ½" HOLES IN CONCRETE AT LEAST 3" DEEP & MOUNT ANCHOR BOOT TO THE GROUND WITH (2) - Ø½" X 2¾" WEDGE ANCHOR BOLTS.

BRASCO INTERNATIONAL, INC.
 1000 MT. ELLIOTT
 DETROIT, MICHIGAN 48207
 1-800-893-3665 WWW.BRASCO.COM

MODEL	SOLAR PACKAGE INSTALL EXPLODED VIEW		
DRAWN BY	SJT	DATE	4-20-09
SCALE	NONE	SHEET	7
THIS DRAWING IS PROPRIETARY AND IS FOR THE SOLE USE OF OUR CUSTOMERS AND MAY NOT BE REPRODUCED OR COPIED WITHOUT WRITTEN PERMISSION FROM BRASCO INTERNATIONAL.			



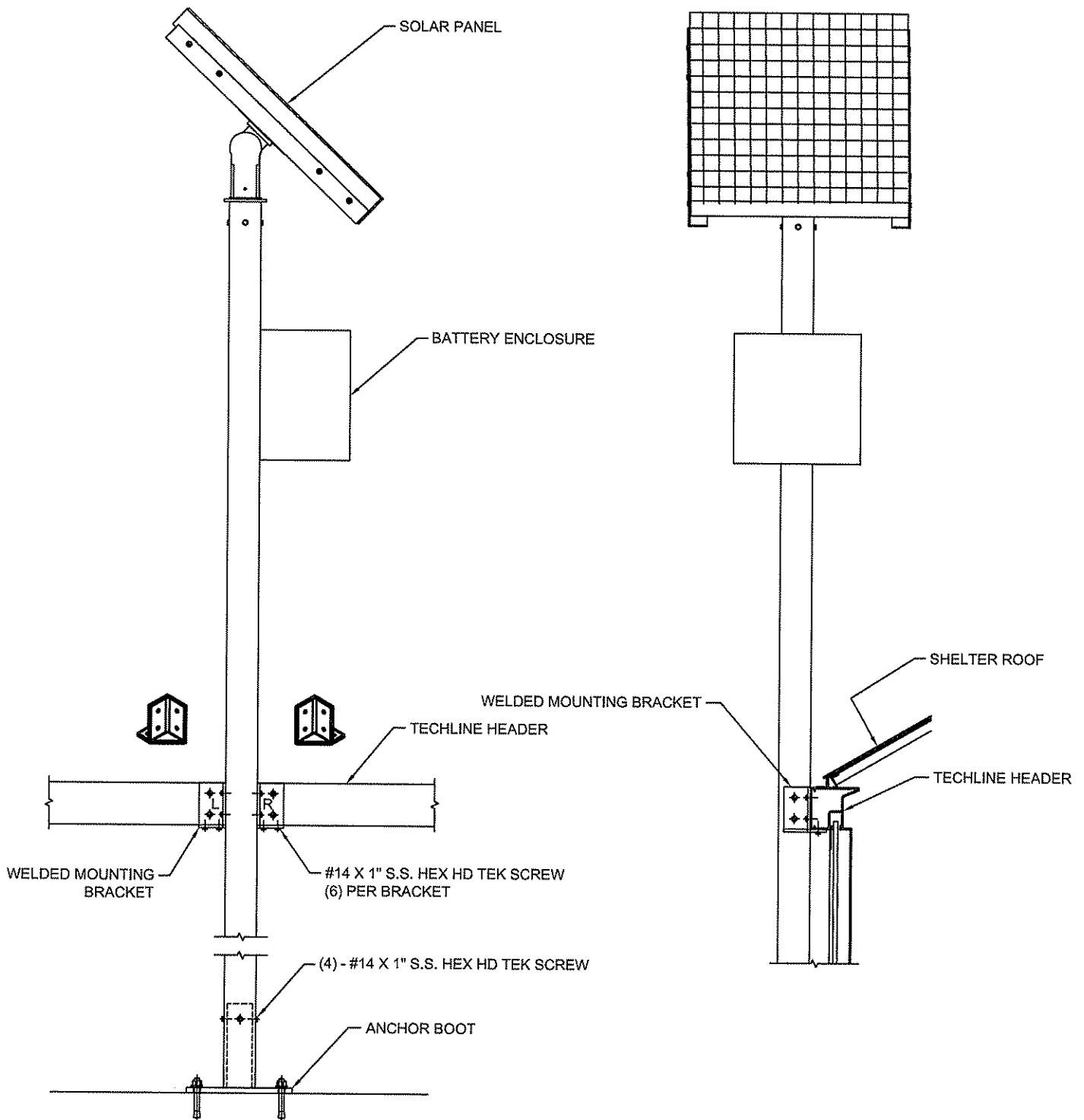

- 15) MOUNT WELDED MOUNTING BRACKET TO SOLAR POST AND HEADER BEAM WITH SUPPORT LEG ON UNDERSIDE OF HEADER USING (6) - #14 X 1" TEK SCREWS PER BRACKET.
 16) MOUNT SOLAR POST TO ANCHOR BOOT USING (4) - #14 X 1" TEK SCREWS.

BRASCO INTERNATIONAL, INC.
 1000 MT. ELLIOTT
 DETROIT, MICHIGAN 48207
 1-800-893-3665 WWW.BRASCO.COM

MODEL	SOLAR PACKAGE INSTALL EXPLODED VIEW		
DRAWN BY	SJT	DATE	4-20-09
SCALE	NONE	SHEET	8
THIS DRAWING IS PROPRIETARY AND IS FOR THE SOLE USE OF OUR CUSTOMERS AND MAY NOT BE REPRODUCED OR COPIED WITHOUT WRITTEN PERMISSION FROM BRASCO INTERNATIONAL.			



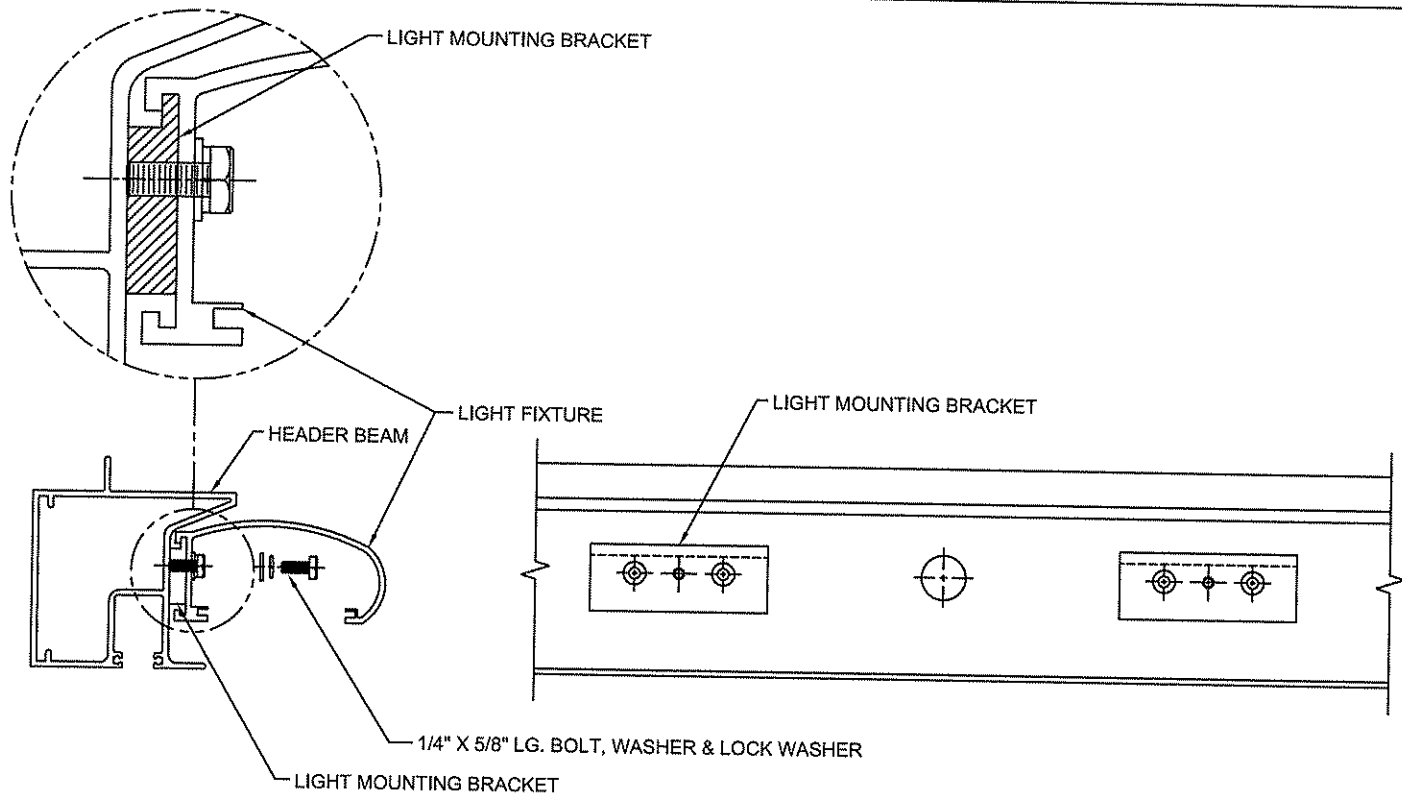

- 17) REMOVE (1) SIDE PLATE AND LENS FROM LIGHT FIXTURE. CONNECT WIRING TO LIGHT FIXTURE. FEED EXCESS WIRE INTO HEADER.
- 18) HANG LIGHT FIXTURE ON MOUNTING BRACKETS & ATTACH USING (2) - $\frac{1}{4}$ " X $\frac{5}{8}$ " BOLTS WITH FLAT WASHERS AND LOCK WASHERS.
- 19) REPLACE LENS AND SIDE PLATE.

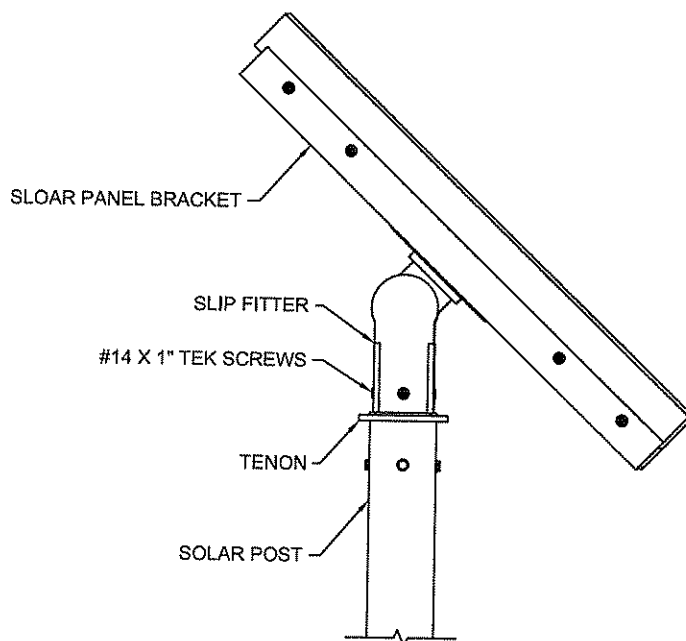

- 20) FACE SOLAR PANEL TO THE SOUTH AND VERIFY ANGLE (45° IS RECOMMENDED). ATTACH CAP TO SLIP FITTER.
- 21) ATTACH SLIP FITTER TO TENON WITH (4) - #14 X 1" TEK SCREWS.
- 22) TURN ON SUN LIGHT CONTROLLER WITH RED RESET BUTTON.
- 23) PRESS TEST BUTTON TO ENSURE LIGHT FUNCTIONS PROPERLY.
- 24) CLOSE AND LOCK BATTERY BOX.

BRASCO INTERNATIONAL, INC.
 1000 MT. ELLIOTT
 DETROIT, MICHIGAN 48207
 1-800-893-3665 WWW.BRASCO.COM

MODEL SOLAR PACKAGE INSTALL EXPLODED VIEW

DRAWN BY SJT DATE 4-20-09

SCALE NONE SHEET 9

THIS DRAWING IS PROPRIETARY AND IS FOR THE SOLE USE OF OUR CUSTOMERS AND MAY NOT BE REPRODUCED OR COPIED WITHOUT WRITTEN PERMISSION FROM BRASCO INTERNATIONAL.



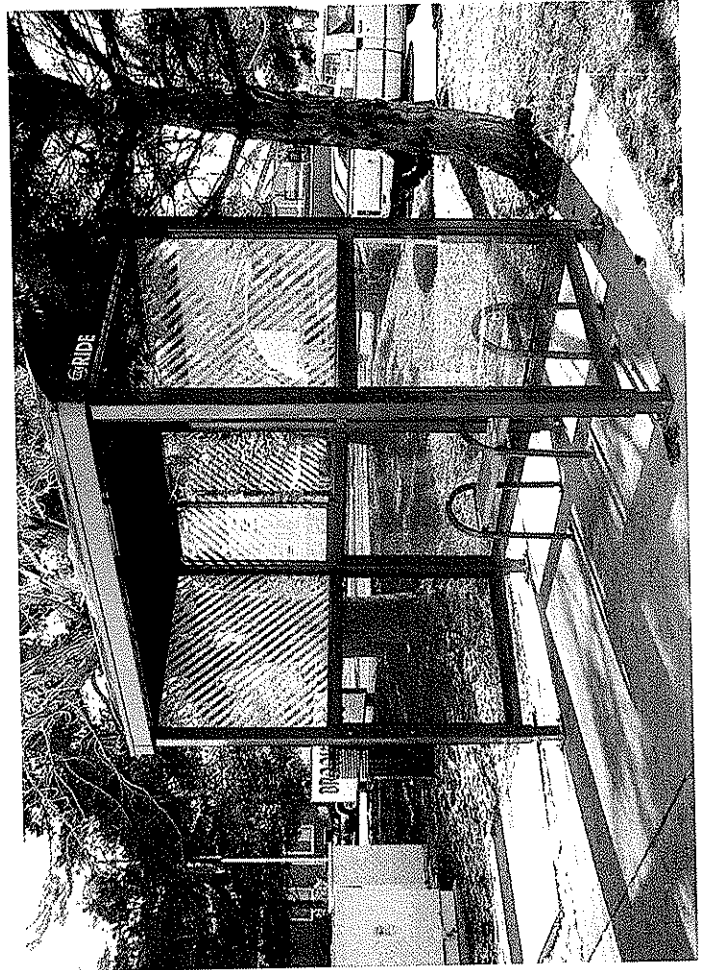

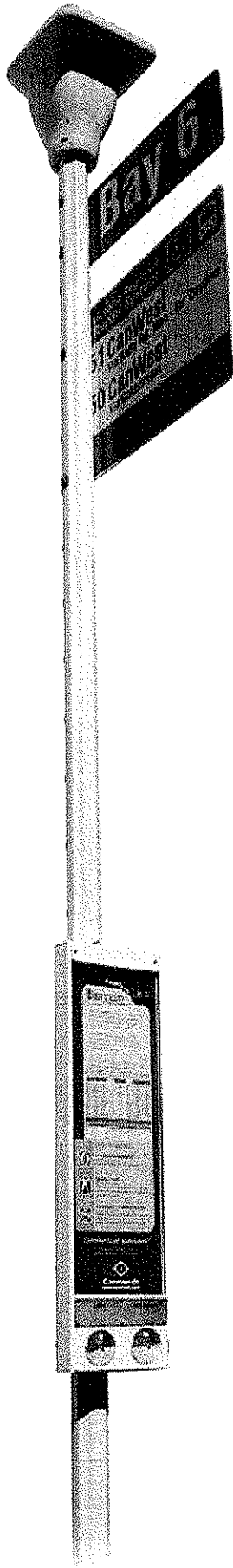

Solar Powered Transit Stop with LED Lighting

- Lighting with the push of a button
- Pole mounted design
- Bus signal device
- Security down lighting
- Warranted for one year
- Proprietary Drawings and Installation Guide can be submitted upon request

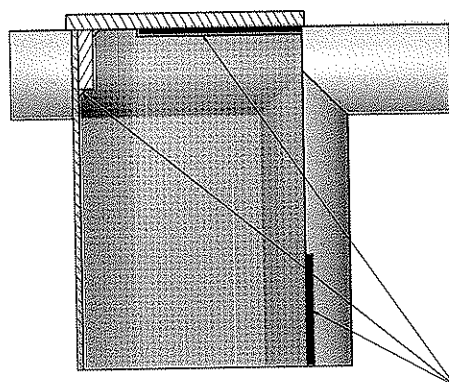
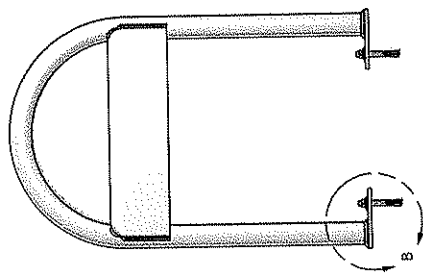
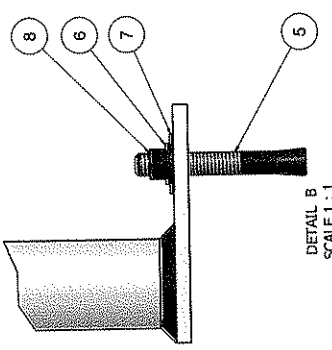
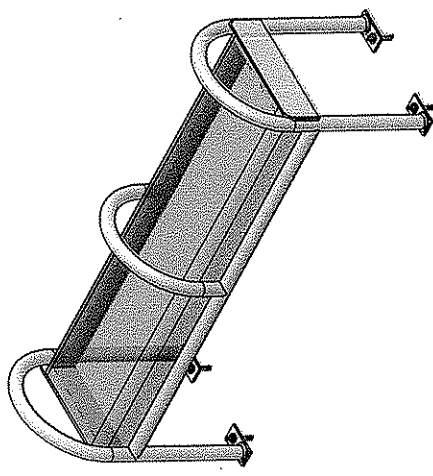
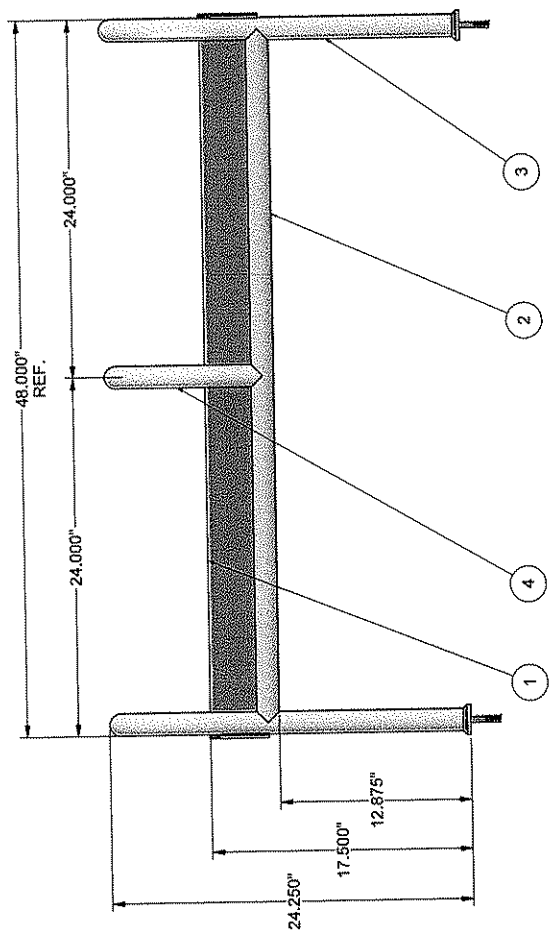
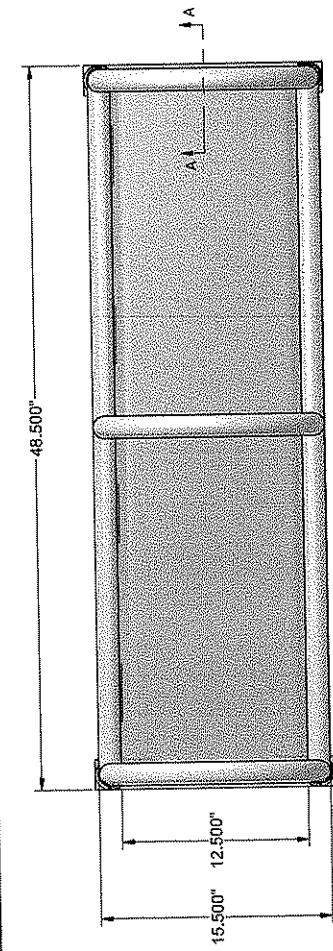

AREA SHOWN FOR WELDING
BENCH SEAT TO FRAME

BRASCO INTERNATIONAL PARTS LIST		
ITEM	QTY	DESCRIPTION
1	1	BENCH FRAME ASSEMBLY - BENCH SEAT
2	2	BENCH FRAME ASSEMBLY - SUPPORT RAIL
3	2	BENCH FRAME ASSEMBLY - BENCH BRACKET
4	1	BENCH FRAME ASSEMBLY - ARMREST
5	4	3/8" 16 X 2 3/4" S.S. WEDGE ANCHOR BOLT
6	4	3/8" S.S. LOCK WASHER
7	4	3/8" S.S. FLAT WASHER
8	4	5/16"-20 S.S. NUT



BRASCO INTERNATIONAL, INC.
1000 AF ELLIOTT
DETROIT, MICHIGAN 48207
1-800-853-3665 WWW.BRASCO.COM

CUSTOMER: BRASCO INTERNATIONAL

PROJECT: 4 PERFORATED BACKLESS BENCH (ALUM.)

DESIGNER: BMB
DATE: 3/3/10
JOB #
SHEET: 1

THIS DRAWING IS PROPRIETARY AND IS FOR THE SOLE USE OF OUR CUSTOMERS AND MAY NOT BE REPRODUCED OR COPIED WITHOUT WRITTEN PERMISSION FROM BRASCO INTERNATIONAL.

RFQ No. PTR 10035

STATE OF WEST VIRGINIA
Purchasing Division

PURCHASING AFFIDAVIT

West Virginia Code §5A-3-10a states: No contract or renewal of any contract may be awarded by the state or any of its political subdivisions to any vendor or prospective vendor when the vendor or prospective vendor or a related party to the vendor or prospective vendor is a debtor and the debt owed is an amount greater than one thousand dollars in the aggregate.

DEFINITIONS:

"Debt" means any assessment, premium, penalty, fine, tax or other amount of money owed to the state or any of its political subdivisions because of a judgment, fine, permit violation, license assessment, defaulted workers' compensation premium, penalty or other assessment presently delinquent or due and required to be paid to the state or any of its political subdivisions, including any interest or additional penalties accrued thereon.

"Debtor" means any individual, corporation, partnership, association, limited liability company or any other form or business association owing a debt to the state or any of its political subdivisions. "Political subdivision" means any county commission; municipality; county board of education; any instrumentality established by a county or municipality; any separate corporation or instrumentality established by one or more counties or municipalities, as permitted by law; or any public body charged by law with the performance of a government function or whose jurisdiction is coextensive with one or more counties or municipalities. "Related party" means a party, whether an individual, corporation, partnership, association, limited liability company or any other form or business association or other entity whatsoever, related to any vendor by blood, marriage, ownership or contract through which the party has a relationship of ownership or other interest with the vendor so that the party will actually or by effect receive or control a portion of the benefit, profit or other consideration from performance of a vendor contract with the party receiving an amount that meets or exceed five percent of the total contract amount.

EXCEPTION: The prohibition of this section does not apply where a vendor has contested any tax administered pursuant to chapter eleven of this code, workers' compensation premium, permit fee or environmental fee or assessment and the matter has not become final or where the vendor has entered into a payment plan or agreement and the vendor is not in default of any of the provisions of such plan or agreement.

Under penalty of law for false swearing (*West Virginia Code* §61-5-3), it is hereby certified that the vendor affirms and acknowledges the information in this affidavit and is in compliance with the requirements as stated.

WITNESS THE FOLLOWING SIGNATURE

Vendor's Name: Brasco International, Inc.

Authorized Signature: *Seaga* Date: 3/12/10

State of MICHIGAN

County of MACOMB, to-wit:

Taken, subscribed, and sworn to before me this 12TH day of MARCH, 2010.

My Commission expires 8/2/2012
CRISTINA BAN
MY COMMISSION EXPIRES

AFFIX SEAL HERE NOTARY PUBLIC - MACOMB COUNTY *Cristina Ban* **RY PUBLIC**