



State of West Virginia  
 Department of Administration  
 Purchasing Division  
 2019 Washington Street East  
 Post Office Box 50130  
 Charleston, WV 25305-0130

# Request for Quotation

RFQ NUMBER:  
**EDD327891**

PAGE:  
**1**

ADDRESS CORRESPONDENCE TO ATTENTION OF:  
**SHELLY MURRAY  
 304-558-8801**

**RFQ COPY**

**TYPE NAME/ADDRESS HERE**

VENDOR

Bridge Information Technology  
 586 Tallwood Road  
 Huntington, WV 25705  
 Phone: 304-736-2800  
 Fax: 304-736-2488

SHIP TO

DEPARTMENT OF EDUCATION  
  
 BUILDING 6  
 1900 KANAWHA BOULEVARD, EAST  
 CHARLESTON, WV  
 25305-0330

DATE PRINTED	TERMS OF SALE	SHIP VIA	F.O.B.	FREIGHT TERMS
04/05/2010				

BID OPENING DATE: **05/13/2010** BID OPENING TIME **01:30PM**

LINE	QUANTITY	UOP	CAT NO	ITEM NUMBER	UNIT PRICE	AMOUNT
0001	1	LS		920-45		
<p>THE WEST VIRGINIA PURCHASING DIVISION, FOR THE AGENCY, THE WEST VIRGINIA DEPARTMENT OF EDUCATION, IS SOLICITING BIDS FOR AN INTERNET FILTERING AND REPORTING SOLUTION PER THE ATTACHED SPECIFICATIONS.</p> <p>TECHNICAL QUESTIONS MUST BE SUBMITTED IN WRITING TO SHELLY MURRAY IN THE WEST VIRGINIA PURCHASING DIVISION VIA MAIL AT THE ADDRESS SHOWN AT THE TOP OF THIS RFQ, VIA FAX AT 304-558-4115, OR VIA E-MAIL AT SHELLY.L.MURRAY@WV.GOV. DEADLINE FOR ALL TECHNICAL QUESTIONS IS 04/27/2010 AT THE CLOSE OF BUSINESS. ALL TECHNICAL QUESTIONS RECEIVED, IF ANY, WILL BE ADDRESSED BY ADDENDUM AFTER THE DEADLINE.</p> <p>INTERNET FILTERING AND REPORTING SOLUTION</p> <p>EXHIBIT 3</p> <p>LIFE OF CONTRACT: THIS CONTRACT BECOMES EFFECTIVE UPON AWARD AND EXTENDS FOR A PERIOD OF ONE (1) YEAR OR UNTIL SUCH "REASONABLE TIME" THEREAFTER AS IS NECESSARY TO OBTAIN A NEW CONTRACT OR RENEW THE ORIGINAL CONTRACT. THE "REASONABLE TIME" PERIOD SHALL NOT EXCEED TWELVE (12) MONTHS. DURING THIS "REASONABLE TIME" THE VENDOR MAY TERMINATE THIS CONTRACT FOR ANY REASON UPON GIVING THE DIRECTOR OF PURCHASING 30 DAYS WRITTEN NOTICE.</p>						

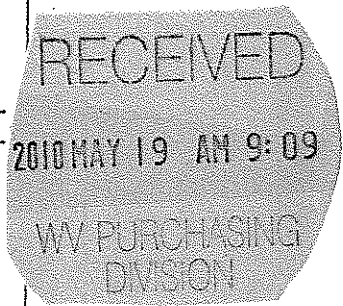

SEE REVERSE SIDE FOR TERMS AND CONDITIONS

SIGNATURE: <i>Stewart Varney</i>	TELEPHONE: 304-736-2800	DATE: 5-19-2010
TITLE: Branch Manager	FEIN: 47-0937677	ADDRESS CHANGES TO BE NOTED ABOVE

WHEN RESPONDING TO RFQ, INSERT NAME AND ADDRESS IN SPACE ABOVE LABELED 'VENDOR'

## GENERAL TERMS & CONDITIONS REQUEST FOR QUOTATION (RFQ) AND REQUEST FOR PROPOSAL (RFP)

1. Awards will be made in the best interest of the State of West Virginia.
2. The State may accept or reject in part, or in whole, any bid.
3. Prior to any award, the apparent successful vendor must be properly registered with the Purchasing Division and have paid the required \$125 fee.
4. All services performed or goods delivered under State Purchase Order/Contracts are to be continued for the term of the Purchase Order/Contracts, contingent upon funds being appropriated by the Legislature or otherwise being made available. In the event funds are not appropriated or otherwise available for these services or goods this Purchase Order/Contract becomes void and of no effect after June 30.
5. Payment may only be made after the delivery and acceptance of goods or services.
6. Interest may be paid for late payment in accordance with the *West Virginia Code*.
7. Vendor preference will be granted upon written request in accordance with the *West Virginia Code*.
8. The State of West Virginia is exempt from federal and state taxes and will not pay or reimburse such taxes.
9. The Director of Purchasing may cancel any Purchase Order/Contract upon 30 days written notice to the seller.
10. The laws of the State of West Virginia and the *Legislative Rules* of the Purchasing Division shall govern the purchasing process.
11. Any reference to automatic renewal is hereby deleted. The Contract may be renewed only upon mutual written agreement of the parties.
12. **BANKRUPTCY:** In the event the vendor/contractor files for bankruptcy protection, the State may deem this contract null and void, and terminate such contract without further order.
13. **HIPAA BUSINESS ASSOCIATE ADDENDUM:** The West Virginia State Government HIPAA Business Associate Addendum (BAA), approved by the Attorney General, is available online at [www.state.wv.us/admin/purchase/vrc/hipaa.htm](http://www.state.wv.us/admin/purchase/vrc/hipaa.htm) and is hereby made part of the agreement. Provided that the Agency meets the definition of a Cover Entity (45 CFR §160.103) and will be disclosing Protected Health Information (45 CFR §160.103) to the vendor.
14. **CONFIDENTIALITY:** The vendor agrees that he or she will not disclose to anyone, directly or indirectly, any such personally identifiable information or other confidential information gained from the agency, unless the individual who is the subject of the information consents to the disclosure in writing or the disclosure is made pursuant to the agency's policies, procedures, and rules. Vendor further agrees to comply with the Confidentiality Policies and Information Security Accountability Requirements, set forth in <http://www.state.wv.us/admin/purchase/privacy/noticeConfidentiality.pdf>.
15. **LICENSING:** Vendors must be licensed and in good standing in accordance with any and all state and local laws and requirements by any state or local agency of West Virginia, including, but not limited to, the West Virginia Secretary of State's Office, the West Virginia Tax Department, and the West Virginia Insurance Commission. The vendor must provide all necessary releases to obtain information to enable the director or spending unit to verify that the vendor is licensed and in good standing with the above entities.
16. **ANTITRUST:** In submitting a bid to any agency for the State of West Virginia, the bidder offers and agrees that if the bid is accepted the bidder will convey, sell, assign or transfer to the State of West Virginia all rights, title and interest in and to all causes of action it may now or hereafter acquire under the antitrust laws of the United States and the State of West Virginia for price fixing and/or unreasonable restraints of trade relating to the particular commodities or services purchased or acquired by the State of West Virginia. Such assignment shall be made and become effective at the time the purchasing agency tenders the initial payment to the bidder.

I certify that this bid is made without prior understanding, agreement, or connection with any corporation, firm, limited liability company, partnership, or person or entity submitting a bid for the same material, supplies, equipment or services and is in all respects fair and without collusion or fraud. I further certify that I am authorized to sign the certification on behalf of the bidder or this bid.

### INSTRUCTIONS TO BIDDERS

1. Use the quotation forms provided by the Purchasing Division. Complete all sections of the quotation form.
2. Items offered must be in compliance with the specifications. Any deviation from the specifications must be clearly indicated by the bidder. Alternates offered by the bidder as **EQUAL** to the specifications must be clearly defined. A bidder offering an alternate should attach complete specifications and literature to the bid. The Purchasing Division may waive minor deviations to specifications.
3. Unit prices shall prevail in case of discrepancy. All quotations are considered F.O.B. destination unless alternate shipping terms are clearly identified in the quotation.
4. All quotations must be delivered by the bidder to the office listed below prior to the date and time of the bid opening. Failure of the bidder to deliver the quotations on time will result in bid disqualifications: Department of Administration, Purchasing Division, 2019 Washington Street East, P.O. Box 50130, Charleston, WV 25305-0130
5. Communication during the solicitation, bid, evaluation or award periods, except through the Purchasing Division, is strictly prohibited (W.Va. C.S.R. §148-1-6.6).



State of West Virginia  
 Department of Administration  
 Purchasing Division  
 2019 Washington Street East  
 Post Office Box 50130  
 Charleston, WV 25305-0130

# Request for Quotation

RFQ NUMBER  
**EDD327891**

PAGE  
**2**

ADDRESS CORRESPONDENCE TO ATTENTION OF  
**SHELLY MURRAY  
 304-558-8801**

## RFQ COPY

TYPE NAME/ADDRESS HERE

Bridge Information Technology  
 586 Tallwood Road  
 Huntington, WV 25705  
 Phone: 304-736-2800  
 Fax: 304-736-2488

DEPARTMENT OF EDUCATION

BUILDING 6  
 1900 KANAWHA BOULEVARD, EAST  
 CHARLESTON, WV  
 25305-0330

DATE PRINTED <b>04/05/2010</b>	TERMS OF SALE	SHIP VIA	F.O.B.	FREIGHT TERMS
-----------------------------------	---------------	----------	--------	---------------

BID OPENING DATE: **05/13/2010** BID OPENING TIME **01:30PM**

LINE	QUANTITY	UQP	CAT. NO.	ITEM NUMBER	UNIT PRICE	AMOUNT
<p>UNLESS SPECIFIC PROVISIONS ARE STIPULATED ELSEWHERE IN THIS CONTRACT DOCUMENT, THE TERMS, CONDITIONS AND PRICING SET HEREIN ARE FIRM FOR THE LIFE OF THE CONTRACT.</p> <p>RENEWAL: THIS CONTRACT MAY BE RENEWED UPON THE MUTUAL WRITTEN CONSENT OF THE SPENDING UNIT AND VENDOR, SUBMITTED TO THE DIRECTOR OF PURCHASING THIRTY (30) DAYS PRIOR TO THE EXPIRATION DATE. SUCH RENEWAL SHALL BE IN ACCORDANCE WITH THE TERMS AND CONDITIONS OF THE ORIGINAL CONTRACT AND SHALL BE LIMITED TO TWO (2) ONE (1) YEAR PERIODS.</p> <p>CANCELLATION: THE DIRECTOR OF PURCHASING RESERVES THE RIGHT TO CANCEL THIS CONTRACT IMMEDIATELY UPON WRITTEN NOTICE TO THE VENDOR IF THE COMMODITIES AND/OR SERVICES SUPPLIED ARE OF AN INFERIOR QUALITY OR DO NOT CONFORM TO THE SPECIFICATIONS OF THE BID AND CONTRACT HEREIN.</p> <p>OPEN MARKET CLAUSE: THE DIRECTOR OF PURCHASING MAY AUTHORIZE A SPENDING UNIT TO PURCHASE ON THE OPEN MARKET, WITHOUT THE FILING OF A REQUISITION OR COST ESTIMATE, ITEMS SPECIFIED ON THIS CONTRACT FOR IMMEDIATE DELIVERY IN EMERGENCIES DUE TO UNFORESEEN CAUSES (INCLUDING BUT NOT LIMITED TO DELAYS IN TRANSPORTATION OR AN UNANTICIPATED INCREASE IN THE VOLUME OF WORK.)</p> <p>BANKRUPTCY: IN THE EVENT THE VENDOR/CONTRACTOR FILES FOR BANKRUPTCY PROTECTION, THE STATE MAY DEEM THE CONTRACT NULL AND VOID, AND TERMINATE SUCH CONTRACT WITHOUT FURTHER ORDER.</p> <p>THE TERMS AND CONDITIONS CONTAINED IN THIS CONTRACT SHALL SUPERSEDE ANY AND ALL SUBSEQUENT TERMS AND CONDITIONS WHICH MAY APPEAR ON ANY ATTACHED PRINTED</p>						

SEE REVERSE SIDE FOR TERMS AND CONDITIONS

SIGNATURE *Stewart Varney* TELEPHONE 304-736-2800 DATE 5-19-2010

TITLE Branch Manager FEIN 47-0937677 ADDRESS CHANGES TO BE NOTED ABOVE

WHEN RESPONDING TO RFQ, INSERT NAME AND ADDRESS IN SPACE ABOVE LABELED 'VENDOR'



State of West Virginia  
 Department of Administration  
 Purchasing Division  
 2019 Washington Street East  
 Post Office Box 50130  
 Charleston, WV 25305-0130

# Request for Quotation

RFQ NUMBER  
**EDD327891**

PAGE  
**3**

ADDRESS CORRESPONDENCE TO ATTENTION OF  
**SHELLY MURRAY  
 304-558-8801**

RECEIVED

**RFQ COPY**  
**TYPE NAME/ADDRESS HERE**  
 Bridge Information Technology  
 586 Tallwood Road  
 Huntington, WV 25705  
 Phone: 304-736-2800  
 Fax: 304-736-2488

SHIP TO

**DEPARTMENT OF EDUCATION**  
**BUILDING 6**  
**1900 KANAWHA BOULEVARD, EAST**  
**CHARLESTON, WV**  
**25305-0330**

DATE PRINTED	TERMS OF SALE	SHIP VIA	F.O.B	FREIGHT TERMS
04/05/2010				

BID OPENING DATE: **05/13/2010** BID OPENING TIME **01:30PM**

LINE	QUANTITY	UOP	CAT NO	ITEM NUMBER	UNIT PRICE	AMOUNT
<p>DOCUMENTS SUCH AS PRICE LISTS, ORDER FORMS, SALES AGREEMENTS OR MAINTENANCE AGREEMENTS, INCLUDING ANY ELECTRONIC MEDIUM SUCH AS CD-ROM.</p> <p style="text-align: center;">NOTICE</p> <p>A SIGNED BID MUST BE SUBMITTED TO:</p> <p style="text-align: center;">DEPARTMENT OF ADMINISTRATION          PURCHASING DIVISION          BUILDING 15          2019 WASHINGTON STREET, EAST          CHARLESTON, WV 25305-0130</p> <p>THE BID SHOULD CONTAIN THIS INFORMATION ON THE FACE OF THE ENVELOPE OR THE BID MAY NOT BE CONSIDERED:</p> <p>SEALED BID</p> <p>BUYER: <b>SHELLY MURRAY</b></p> <p>RFQ. NO.: <b>EDD327891</b></p> <p>BID OPENING DATE: <b>05/13/2010</b></p> <p>BID OPENING TIME: <b>1:30 PM</b></p> <p>PLEASE PROVIDE A FAX NUMBER IN CASE IT IS NECESSARY TO CONTACT YOU REGARDING YOUR BID: <b>304-736-2488</b></p>						

SEE REVERSE SIDE FOR TERMS AND CONDITIONS			
SIGNATURE <i>Stewart Varney</i>	TELEPHONE 304-736-2800	DATE 5-19-2010	
TITLE Branch Manager	FEIN 47-0937677	ADDRESS CHANGES TO BE NOTED ABOVE	

WHEN RESPONDING TO RFQ, INSERT NAME AND ADDRESS IN SPACE ABOVE LABELED 'VENDOR'



State of West Virginia  
 Department of Administration  
 Purchasing Division  
 2019 Washington Street East  
 Post Office Box 50130  
 Charleston, WV 25305-0130

# Request for Quotation

RFQ NUMBER:  
**EDD327891**

PAGE:  
**4**

ADDRESS CORRESPONDENCE TO ATTENTION OF:  
**SHELLY MURRAY  
 304-558-8801**

RFQ COPY  
 TYPE NAME/ADDRESS HERE

Bridge Information Technology  
 586 Tallwood Road  
 Huntington, WV 25705  
 Phone: 304-736-2800  
 Fax: 304-736-2488

DEPARTMENT OF EDUCATION  
 BUILDING 6  
 1900 KANAWHA BOULEVARD, EAST  
 CHARLESTON, WV  
 25305-0330

DATE PRINTED <b>04/05/2010</b>	TERMS OF SALE	SHIP VIA	F.O.B.	FREIGHT TERMS
-----------------------------------	---------------	----------	--------	---------------

BID OPENING DATE: **05/13/2010** BID OPENING TIME **01:30PM**

LINE	QUANTITY	UOP	CAT NO	ITEM NUMBER	UNIT PRICE	AMOUNT
CONTACT PERSON (PLEASE PRINT CLEARLY): <i>Stewart Vanney</i>						
***** THIS IS THE END OF RFQ EDD327891 ***** TOTAL: _____						

SEE REVERSE SIDE FOR TERMS AND CONDITIONS

SIGNATURE *Stewart Vanney* TELEPHONE 304-736-2800 DATE 5-19-2010

TITLE Branch Manager FEIN 47-0937677 ADDRESS CHANGES TO BE NOTED ABOVE

WHEN RESPONDING TO RFQ, INSERT NAME AND ADDRESS IN SPACE ABOVE LABELED 'VENDOR'



State of West Virginia  
 Department of Administration  
 Purchasing Division  
 2019 Washington Street East  
 Post Office Box 50130  
 Charleston, WV 25305-0130

# Request for Quotation

RFQ NUMBER  
**EDD327891**

PAGE  
**1**

ADDRESS CORRESPONDENCE TO ATTENTION OF  
**SHELLY MURRAY**  
**304-558-8801**

VENDOR

**RFQ COPY**  
**TYPE NAME/ADDRESS HERE**  
 Bridge Information Technology  
 586 Tallwood Road  
 Huntington, WV 25705  
 Phone: 304-736-2800  
 Fax: 304-736-2488

SHIP TO

**DEPARTMENT OF EDUCATION**  
**BUILDING 6**  
**1900 KANAWHA BOULEVARD, EAST**  
**CHARLESTON, WV**  
**25305-0330**

DATE PRINTED	TERMS OF SALE	SHIP VIA	F.O.B.	FREIGHT TERMS		
05/04/2010						
BID OPENING DATE: 05/19/2010		BID OPENING TIME: 01:30PM				
LINE	QUANTITY	UOP	CAT. NO.	ITEM NUMBER	UNIT PRICE	AMOUNT
ADDENDUM NO. 1						
<p>THIS ADDENDUM IS ISSUED TO ADDRESS THE QUESTIONS RECEIVED PRIOR TO THE QUESTION SUBMISSION DEADLINE OF 04/27/2010.</p> <p>THE BID OPENING DATE IS EXTENDED:</p> <p>FROM: 05/13/2010          TO : 05/19/2010</p>						
0001	1	LS		920-45		
INTERNET FILTERING AND REPORTING SOLUTION						
EXHIBIT 10						
REQUISITION NO.: EDD327891						
ADDENDUM ACKNOWLEDGEMENT						
I HEREBY ACKNOWLEDGE RECEIPT OF THE FOLLOWING CHECKED ADDENDUM(S) AND HAVE MADE THE NECESSARY REVISIONS TO MY PROPOSAL, PLANS AND/OR SPECIFICATION, ETC.						
ADDENDUM NO. 'S:						
NO. 1 ... ✓ .....						
NO. 2 .....						
NO. 3 .....						
SEE REVERSE SIDE FOR TERMS AND CONDITIONS						
SIGNATURE <i>Stewart Varney</i>		TELEPHONE 304-736-2800		DATE 5-19-2010		
TITLE Branch Manager		FERN 47-0937677		ADDRESS CHANGES TO BE NOTED ABOVE		

WHEN RESPONDING TO RFQ, INSERT NAME AND ADDRESS IN SPACE ABOVE LABELED 'VENDOR'



Bridge Information Technology  
586 Tallwood Road  
Huntington, WV 25705  
Phone: 304-736-2800 Fax: 304-736-2488

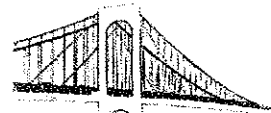

Bridging the gap between business and technology

Date: 5-18-2010

## RFQ: EDD327891 Internet Filtering and Reporting Solution

### Summary of Submittal

Enclosed: Summary of Submittal (this page)  
Original RFQ  
Addendum Acknowledgement  
RFQ Response  
Cost Sheet  
Purchasing Affidavit  
Vendor Preference Certificate (no points)  
Letter of Authorization (Cymphonix)

The enclosed solution provided by Bridge I.T. will meet the needs of the RFQ: EDD327891 for the WVDOE. The single source product we are offering is the Cymphonix Network Composer / Conductor. This enterprise class network appliance that can be centrally managed and was designed for networks such as the K12 network. Having its own operating system and housed in self contained rack mount units, it has a small footprint in the network cabinet. In addition, it doesn't rely on servers or other known operating systems to work. This will reduce maintenance and support costs on your servers as well as reducing the load a software based solution would produce.

#### Hardware Summary:

- 8- EX600 Network Composers (Three active units at each location and one failover)
- 1- EC700 Network Conductor (Housed at either location and can manage up to 100 Network Composers)

Thank you for the opportunity to place this bid for the K-12 Internet and Reporting Solution. Please don't hesitate to contact me with any questions you may have.

Stewart Varney  
PH: 304-736-2800  
FAX: 304-736-2488  
stewart.varney@bridgeit.com



State of West Virginia  
 Department of Administration  
 Purchasing Division  
 2019 Washington Street East  
 Post Office Box 50130  
 Charleston, WV 25305-0130

# Request for Quotation

RFQ NUMBER  
 EDD327891

PAGE  
 2

ADDRESS CORRESPONDENCE TO ATTENTION OF  
 SHELLY MURRAY  
 304-558-8801

## RFQ COPY

TYPE NAME/ADDRESS HERE

Bridge Information Technology  
 586 Tallwood Road  
 Huntington, WV 25705  
 Phone: 304-736-2800  
 Fax: 304-736-2488

DEPARTMENT OF EDUCATION

BUILDING 6  
 1900 KANAWHA BOULEVARD, EAST  
 CHARLESTON, WV  
 25305-0330

DATE PRINTED	TERMS OF SALE	SHIP VIA	FOB	FREIGHT TERMS		
05/04/2010						
BID OPENING DATE: 05/19/2010		BID OPENING TIME 01:30PM				
LINE	QUANTITY	UGP	CAT. NO.	ITEM NUMBER	UNIT PRICE	AMOUNT
NO. 4	.....					
NO. 5	.....					
<p>I UNDERSTAND THAT FAILURE TO CONFIRM THE RECEIPT OF THE ADDENDUM(S) MAY BE CAUSE FOR REJECTION OF BIDS.</p> <p>VENDOR MUST CLEARLY UNDERSTAND THAT ANY VERBAL REPRESENTATION MADE OR ASSUMED TO BE MADE DURING ANY ORAL DISCUSSION HELD BETWEEN VENDOR'S REPRESENTATIVES AND ANY STATE PERSONNEL IS NOT BINDING. ONLY THE INFORMATION ISSUED IN WRITING AND ADDED TO THE SPECIFICATIONS BY AN OFFICIAL ADDENDUM IS BINDING.</p> <p style="text-align: center;"><i>Stewart Kasney</i> SIGNATURE</p> <p style="text-align: center;"><i>Bridge Information Technology</i> COMPANY</p> <p style="text-align: center;">5-19-2010 DATE</p> <p>NOTE: THIS ADDENDUM ACKNOWLEDGEMENT SHOULD BE SUBMITTED WITH THE BID.</p> <p style="text-align: center;">----- END OF ADDENDUM NO. 1 -----</p>						

SEE REVERSE SIDE FOR TERMS AND CONDITIONS

SIGNATURE <i>Stewart Kasney</i>	TELEPHONE 304-736-2800	DATE 5-19-2010
TITLE Branch Manager	FEIN 47-0937677	ADDRESS CHANGES TO BE NOTED ABOVE

WHEN RESPONDING TO RFQ, INSERT NAME AND ADDRESS IN SPACE ABOVE LABELED 'VENDOR'



# West Virginia Department of Education

## REQUEST FOR QUOTATION

### EDD327891

#### Introduction

The West Virginia Department of Education (WVDE) is soliciting quotations for an **Internet filtering and reporting solution** that consists of software, licensing, software upgrades/updates, database updates and technical support. The vendor has the option to include servers or appliances and associated costs in the quotation if the vendor's software will not meet the requirements of this RFQ when installed on WVDE owned servers which are described in Section I-Current Environment.

**Throughout this Request for Quotation (RFQ) the term "filtering solution" is used to refer to all vendor provided software and hardware used to perform Internet filtering and reporting functions, including but not limited to application software, operating system and database software.**

**The terms "server" and "servers" are used to refer to the hardware or appliances on which any component of the filtering solution is installed.**

**Every statement of this RFQ that includes the word "must" or "shall" is a mandatory requirement. A vendor should not submit a bid if the filtering solution cannot meet every mandatory requirement.**

The products and services that are bid **must** be capable of providing a level of service appropriate for Internet Service Provider (ISP) facilities with 3 gigabits of Internet bandwidth. School based or district based filtering solutions are not an acceptable response to this RFQ.

The WVDE currently has two independent Internet connections for the K-12 public schools. Internet filtering solutions **must** be installed at both Points of Presence (POP). Because of the diverse needs of schools, the WVDE **must** have selective filtering levels and capabilities for delegated administration of tailored filtering policies or profiles for different subnets. Updates to the filtering solution **must** be provided at least once each day to ensure that the filtering database is up-to-date using multiple methods and resources for the review of content on Internet sites. The Internet filtering **must** meet the requirements of the E-rate program (refer to <http://www.sl.universalservice.org/>) and the West Virginia Board of Education Policy 2460 that is available online at <http://wvde.state.wv.us/policies/p2460.html>.

Information relevant to the Children's Internet Protection Act (CIPA) and the Federal requirement to implement Internet filtering is detailed at the URL <http://www.fcc.gov/cgb/consumerfacts/cipa.html>.

The Children's' Online Privacy Protection Act (COPPA) **must** not be violated by any requirements of the filtering solution to collect personal information about students. Refer to <http://www.ftc.gov/coppa/> for information about COPPA.

## **Section I - Current Environment**

Approximately 700 public schools in 57 school districts of West Virginia are connected with a privately addressed TCP/IP statewide network. The network uses the private Class A range of 10.0.0.0 IP addresses. The POPs are equipped with Cisco 6513 switches that contain Cisco router and Cisco PIX firewall modules that route and translate the private IP addresses to our Class B 168.216.0.0 public network IP addresses. A Packeteer appliance is used to manage bandwidth. The Internet filtering **shall** be done at the two POPs where the K-12 network is routed to the ISP. The POPs are located in the WVNET facilities in Morgantown, WV and in the IS&C facilities at Building 6 of the State Capitol Complex at Charleston, WV. Each one of the two POPs connects approximately 70,000 unique computers to the Internet with 3 gigabits/second of bandwidth.

**POP Site #1 Charleston, WV, is equipped with the following WVDE owned servers on which the filtering solution may be installed.**

8 (eight) Dell 2850 servers with following specifications:  
3 GHz XEON Processor with 2 MB cache, 2 GB DDR2 dimm, dual 73GB scsi drives in mirrored RAID, dual onboard gigabit copper ethernet NICs.

1 (one) Dell 2850 servers with following specifications:  
3 GHz XEON Processor with 2 MB cache, 2 GB DDR2 dimm, dual 73GB scsi drives in mirrored RAID, dual onboard gigabit copper ethernet NICs, and one 1 TB storage for reports and log files.

**POP Site #2 Morgantown, WV, is equipped with the following WVDE owned servers on which the filtering solution may be installed:**

8 (eight) Dell 2850 servers with following specifications:  
3 GHz XEON Processor with 2 MB cache, 2 GB DDR2 dimm, dual 73GB scsi drives in mirrored RAID, dual onboard gigabit copper ethernet NICs.

1 (one) Dell 2850 servers with following specifications:  
3 GHz XEON Processor with 2 MB cache, 2 GB DDR2 dimm, dual 73GB scsi drives in mirrored RAID, dual onboard gigabit copper ethernet NICs, and one 1 TB storage for reports and log files.

If the servers described above are not adequate to support the vendor's filtering solution, the vendor **must** include appropriate servers or appliances and associated costs in the response to this RFQ.

The total number of computers to be filtered is approximately 140,000 computers. The Internet filtering **must** occur at the point in the network after which the K-12 core routers consolidate Internet traffic but before the firewall dynamically changes the private IP addresses to public IP addresses as shown in the diagram on attachment A. The filtering servers and reporting servers **must** operate within the scope of the K-12 private network so that filtering control and reporting will reflect the private IP addresses of the client computers. In the event that portable computers are connected to residential, public, or other networks, an option **must** be available to provide continued filtering of Internet web sites. No caching appliances are currently in use: however the Internet filtering solution must support the option for the WVDE to install caching appliances.

## **Section II - Technical Requirements**

### **General**

The vendor bid **must** provide an Internet filtering solution capable of filtering 140,000 total computers in a network consisting of two POPs. The solution **must** be configured to support 70,000 client computers using 3 gigabits/sec of bandwidth at each POP.

**The Cymphonix solution as proposed by Bridge IT will support the user count and bandwidth requirements as listed above.**

The vendor **must** provide evidence of at least one current, successful installation of the Internet filtering solution in a network configuration servicing 70,000 computers with 3 gigabits/second of Internet bandwidth.

### **Pinellas Independent School District**

The filtering solution **must** be a POP based installation; a filtering solution which involves the installation of filtering software or hardware school districts or individual schools is not acceptable.

**The Cymphonix solution as proposed by Bridge IT will comply to the POP installation**

The vendor **must** provide Internet filtering and reporting application software and all necessary supporting software including, but not limited to, operating system and database software.

**The Cymphonix solution as proposed by Bridge IT contains all software, hardware, reporting and database requirements.**

The Internet filtering solution **must** meet the requirements of this RFQ using servers/appliances provided by the vendor or when installed on the WVDE owned equipment identified in Section I - Current Environment

**The Cymphonix solution as proposed by Bridge IT includes EX and EC series hardware which will not require any additional WVDE resources outside of what has been include in Section I –Current Environment**

The WVDE will provide server hardware, equipment racks, networking components and cabling as specified in Section I - Current Environment

### **Understood**

The filtering solution **must** support gigabit speed, copper based, Ethernet network interfaces.

**The Cymphonix solution as proposed by Bridge IT is in compliance**

The filtering solution **must** not exceed a total of 12 servers or appliances at each POP.

**The Cymphonix solution as proposed by Bridge IT would include 5 devices at one POP location and 4 at the other. Three primary devices and a single fail over device at each POP and one Network Conductor at the location of your choice. The Network Conductor is used to manage and synchronize the Network Composers.**

The total of all hardware components of the filtering solution for each POP **must** be rack mountable and not occupy more than 24 units of rack space (about 48") at each POP site. The equipment must operate on 110-120 Volts AC power

**The Cymphonix solution as proposed by Bridge IT includes 5 total devices at one POP and 4 at the other and are all rack mountable. The odd numbered device at one location is the Network Conductor (1) which is used to push out rules and policies to the other units. Each device would require 2 units of rack space totaling 8 total units at one location and 10 at the other. Each device operates on 110-120 Volts AC power.**

In the event the winning bid does not meet the requirements of this RFQ when installed on vendor provided server/appliances or on the existing equipment identified in Section 1 Current Environment, the vendor **must** provide additional servers and any other associated installation, shipping, labor and configuration expenses at no cost to the WVDE or the contract will be immediately terminated.

**Agreed**

There **must** be no requirement for any configuration changes of any networking equipment or computers that are connected to the private WV K-12 network at the school districts or individual schools.

**Based in the information contained in this RFQ and the additional questions submitted and responded to, the Cymphonix solution as proposed by Bridge IT would not require any changes in networking equipment or computers connected to the WV K-12 network for IP based reporting and filtering.**

The filtering solution **must** provide client software which can be installed on mobile computers that will enforce the same filtering parameters whether a mobile computer is connected to the WV K-12 network or connected by wired or Wireless networking to the Internet via any other Internet service provider. The client software **must** not be a VPN (virtual private networking) or similar type of client and **must** not rely on a web browser setting such as a proxy server configuration.

**The Cymphonix solution as proposed by Bridge IT includes a mobile client software that meets the above criteria.**

The filtering solution **must** have the capability to filter based on the IP address of the client computer and not require user authentication.

**The Cymphonix solution as proposed by Bridge IT is able to filter on IP address and not require user authentication.**

The filtering solution **must** have the capability to be integrated with unified authentication systems such as LDAP and Active Directory service.

**The Cymphonix solution as proposed by Bridge IT includes the ability to integrate to such systems.**

The Internet filtering solution **must** be engineered and operate with redundancy such that the failure of one server or appliance at a POP will not reduce the capability to provide filtering for 70,000 computers at 3 gigabits/sec of throughput.

**The Cymphonix solution as proposed by Bridge IT includes as requested, a back up device that will allow for the continued filtering of the client computers should an appliance fail.**

The vendor **must** begin installation no later than 30 days after receipt of the purchase order and must be completed within 60 days of receipt of the purchase order.

**Bridge IT accepts the timeline conditions and can perform as requested.**

### **Internet Filtering**

The filtering solution **must** provide a web based interface for all management and configuration tasks which can be performed by WVDE.

**The Cymphonix solution as proposed by Bridge IT is managed and configured via a Web Based Interface.**

The filtering solution **must** have the capability to be configured to block Internet access in the event of the failure of the filtering solution at a POP so that unfiltered Internet access is prevented.

**The Cymphonix solution as proposed by Bridge IT includes the ability to configure the solution to block Internet access if an appliance fails**

The Internet filtering provided as a result of this RFQ **must** be verified by the vendor to meet the requirements of the Children's Internet Protection Act (CIPA) (refer to <http://www.fcc.gov/cgb/consumerfacts/cipa.html>) and the West Virginia Board of Education Policy 2460 that is available online at <http://wvde.state.wv.us/policies/p2460.html>.

**The Cymphonix solution as proposed by Bridge IT has been installed in many educational organizations all across North America in order to satisfy CIPA requirements. Policy 2460 from the West Virginia Board of Education has been reviewed and the proposed solution meets the standards defined therein.**

The filtering solution **must** be verified by the vendor to comply with the Children's Online Privacy Protection Act (COPPA). The filtering process **must** not require the collection of any personal information from any users under the age of 13.

**The Cymphonix solution as proposed by Bridge IT requires no collection of personal data and relies on the existing systems to allow authenticated, user name based access to the Internet. Using the IP based reporting and management no authentication to the Cymphonix solution is required.**

The filtering solution **must** provide the capability for the WVDE to selectively enable filtering of content based on categories of web sites or individual web sites using the http and https protocols.

**The Cymphonix solution as proposed by Bridge IT allows for full content management both in HTTP and HTTPS encryption types. This management functionality includes the ability to block/allow/shape/prioritize across web categories and individual web sites.**

The vendor **must** include all categories that the vendor offers on the product. The vendor **must** not offer a reduced number of categories in an attempt to reduce costs by providing only the categories that are identified in this RFQ.

**The Cymphonix solution as proposed by Bridge IT includes all categories available on the Cymphonix Network Composer appliance.**

The vendor **must** provide, but is not limited to, the pre-populated categories of the following classifications or equivalent classifications of content on web sites:

-Pornography

**Yes**

-Obscenity

**Yes**

-Dating (including sites for the purpose of establishing personal relationships)

**Yes**

-Gambling

**Yes**

-Criminal Activities (sites that condone or provide instructions for criminal activity)

**Yes**

-Illegal Drugs (sites that condone or provide instructions for illegal drug use, manufacturing and distribution)

**Yes**

-Anonymous Proxies (anonymizers to bypass filtering or hide the true source of Internet activity)

**Yes**

-Computer crimes, cracking and hacking (sites that condone or provide instructions for these activities)

**Yes**

-Malicious code (sites that contain, distribute, or execute malicious code such as malware, viruses, root kits, bots, etc or retrieve information from computers that are infected with malicious code)

**Yes**

-Instant messaging sites

**Yes**

-Peer to Peer (P2P sites)

**Yes**

-Phishing (fraudulent sites that imitate authentic sites, often to lure people into submitting personal or financial information.)

**Yes**

-Hate, racism, discrimination (sites that condone or encourage violence against or suppression of any minorities or grouping based on race, religion, sexual orientation, ethnicity or any other social grouping characteristic)

**Yes**

The filtering solution **must** have the capability to allow or deny access to any individual web site, URL, or IP address whether or not it is included in any vendor provided category.

**The Cymphonix solution as proposed by Bridge IT allows the administrators of the system to allow or deny access based on web site, URL or ip address.**

The filtering solution **must** have the capability to permit the WVDE to create unlimited additional custom categories.

**The Cymphonix solution as proposed by Bridge IT allows for unlimited custom categories**

The filtering solution **must** have the capability to permit the use of "regular expressions" (includes wild-card characters and other variables to specify complex text strings) when creating custom allow or deny lists of URL web addresses or search terms.

**The Cymphonix solution as proposed by Bridge IT allows the use of regular expressions when creating the deny/allow lists.**

The filtering solution **must** have the capability to block traffic related to peer-to-peer file sharing protocols.

**The Cymphonix solution as proposed by Bridge IT will block peer to peer in multiple methods, including the web sites where one might download these files and clients but also the applications themselves if they have already been installed and are attempting to move peer to peer files**

The filtering solution **must** have the capability to enforce the "safe searching" mode of Google, Bing and Yahoo search engines, regardless of the settings chosen by an end user that is using those search engines.

**The Cymphonix solution as proposed by Bridge IT includes the ability to enforce safe searches across all major search engines including Google, Bing, and Yahoo.**

The filtering solution **must** provide capabilities to create manageable client groups based on IP address ranges and assign names to those groups.

**The Cymphonix solution as proposed by Bridge IT has the ability to create groups based on IP ranges among other additional logical or physical network parameters**

The capability **must** exist to delegate management of groups by creating additional administrators with restricted rights who can be assigned to manage filtering parameters for specific groups.

**The Cymphonix solution as proposed by Bridge IT also includes the ability to delegate the management and reporting of groups to administrators with a subset of rights and privileges.**

The filtering solution **must** provide for customizable, granular permissions so that additional administrator/user accounts can be tailored on a user by user basis to match the rights of a user to the tasks that a user needs to perform.

**The Cymphonix solution as proposed by Bridge IT includes the ability to create report only/manage only or report and manage as granular permission types. Those rights can then be isolated by user, group, ip range etc.**



The filtering solution **must** have the capability to selectively display WVDE customized "site blocked" pages based on the client group and/or the categorization of the blocked web site.

**The Cymphonix solution as proposed by Bridge IT allows for each defined group to have their own customized block page if desired.**

The filtering solution **must** have the capability to selectively display WVDE customized "informational" pages based on the client group and/or the categorization of web sites to which access is allowed.

**The Cymphonix solution as proposed by Bridge IT allows the administrator(s) access to the HTML code so that any customized page result can be deployed.**

The filtering solution **must** have the capability to be configured to only perform filtering of outgoing requests and to perform no filtering of incoming traffic.

**The Cymphonix solution as proposed by Bridge IT can be configured to perform as requested.**

The product offered by the vendor **must** perform Internet filtering primarily by comparing outgoing requests to a database of categorized URLs and IP addresses to determine whether an attempt to access a site on the Internet is to be blocked or permitted.

**The Cymphonix solution as proposed by Bridge IT includes multiple levels of content identification, the primary form is to compare against a list of categorized URL's and IP addresses.**

Any other Internet filtering methods of the filtering solution, such as "on the fly" evaluation of incoming content, **must** be able to be selectively disabled at the option of the WVDE.

**The Cymphonix solution as proposed by Bridge IT performs as requested**

The filtering solution **must** provide a web based display of status and performance graphs for all components of the filtering solution.

**The Cymphonix solution as proposed by Bridge IT includes detailed reports via the web interface that inform the administrators of all key areas of the filtering systems performance**

The filtering solution **must** have the capability for the WVDE to set customized filtering policies based on the time of day and the day of the week for individual IP addresses and/or groups of client IP addresses.

**The Cymphonix solution as proposed by Bridge IT includes these capabilities**

The Internet filtering solution **must** not masquerade, spoof or change the source IP address of the computers on the K-12 network. The source IP address of the client computer must be passed to the PIX firewall.

**The Cymphonix solution as proposed by Bridge IT will send the source IP address of the client computers through to the PIX firewall**

The Internet filtering and reporting servers **must** operate on and report on the 10.0.0.0 private network IP addresses of the WVDE K-12 network.

**The Cymphonix solution as proposed by Bridge IT can be configured to operate as requested.**

The filtering solution **must** have a synchronization capability. Synchronization means that when the WVDE makes a filtering configuration change using the web management tool, that change will be distributed to all of the filtering servers at both POPs. That change distribution **must** take effect automatically within 5 minutes after the act of saving of the configuration change, or be accomplished manually with no more than 5 mouse clicks after the configuration change is saved.

**The Cymphonix solution as proposed by Bridge IT includes a Cymphonix Conductor which performs the tasks requested above. Both the time request or the mouse click request can be satisfied.**

### **Internet Use Reporting**

The filtering solution **must** provide a web-based reporting application and a minimum of one terabyte of log file storage at each POP.

**The Cymphonix solution as proposed by Bridge IT includes reporting capabilities as part of the integrated web interface. The appliances proposed contain 2 Terabyte storage drives-1 as primary and 1 as a redundant drive.**

The filtering solution **must** provide a method for the WVDE to download log files in a generic text format for analysis and archival storage.

**The Cymphonix solution as proposed by Bridge IT provides this ability via a database connector which allows WVDE to access the data stored by the solution at anytime and can be shared in any number of generic text formats. This process can also be automated.**

Complete details of web browsing activity **must** be stored in log files and must include, at a minimum, the complete URL, date and time and IP address of the client computer.

**The Cymphonix solution as proposed by Bridge IT includes the ability to store all the information requested.**

All end user functions of the reporting application **must** be accessible via a web interface.

**The Cymphonix solution as proposed by Bridge IT includes all end user management and reporting functions as part of the web interface**

The reporting solution **must** provide the capability to create reports based on specific IP address, web site address, date and time of day.

**The Cymphonix solution as proposed by Bridge IT will comply to this reporting request**

The reporting capabilities **must** include the ability to schedule aggregate reports of web site accesses by categories, ranges of IP addresses and time periods.

**The Cymphonix solution as proposed by Bridge IT will comply to this reporting request**

The reporting capabilities **must** include the ability to create "on demand" custom reports on selected client IP addresses, specific URLs and time periods.

**The Cymphonix solution as proposed by Bridge IT carries a unique web interface which allows for on demand production of reports that include client IP addresses, URLs and time periods**

### **Section III - Contract Terms**

The contract that results from this RFQ will remain in effect for one (1) year from the date of award, with an option to renew for two (2) additional one (1) year periods.

#### **Understood**

The costs for software and the annual licensing for Internet filtering can be invoiced upon delivery and acceptance by the WVDE. The technical support costs are payable in arrears and **shall** be invoiced not more often than on a monthly basis.

#### **Understood**

Any terms and conditions **must** be submitted with the bid. After award, no changes will be allowed which modify and terms and conditions. Award will not be made until all terms and conditions are agreed to by the State.

#### **Understood**

The vendor is solely responsible for all work performed under the contract and for all services offered and products to be delivered under the terms of this contract.

#### **Understood**

If the successful vendor is not the direct source, the vendor **must** provide documentation of being an authorized reseller to provide the equipment, filtering updates, maintenance and technical support.

## **Understood and included**

### **Section IV - Service Requirements**

The vendor **must** provide modification or replacement of software that fails to perform according to the specifications. The vendor also **must** provide any software upgrades, at no cost to the State, that are necessary during the term of the contract in order to continue to meet the Internet filtering capabilities specified. This requirement includes replacement, at no cost to the State, which may be necessary due to possible end-of-life designation by the manufacturer.

#### **Understood**

The WVDE network staff will provide and maintain WVDE provided servers, associated networking hardware and wiring. The WVDE network engineers will be responsible for load balancing network traffic to the servers of the filtering solution. The WVDE will be responsible for purchasing additional servers and network hardware when necessary to accommodate increases in bandwidth the number of clients to be filtered.

#### **Understood**

The filtering solution installation, configuration and testing at both the Charleston and Morgantown sites **must** be completed by the vendor within 30 days after the award of the contract. The vendor is responsible for any transportation and lodging costs of the installer.

#### **Understood**

The Internet filtering **must** support the bandwidth requirements of 3 gigabits/sec and 70,000 client computers at each one of the two POPs as identified in the specifications in Section II Technical Requirements.

#### **Understood**

The vendor understands that technical support includes verifying that all hardware and/or software remains operational in the event of WVDE modification, replacement or upgrade of any servers or network configurations that impact the functioning of the filtering solution. These costs are to be included in the line item for technical support on the cost page.

#### **Understood**

Toll-free telephone and e-mail technical support **must** be available 7:00 AM to 5:00 PM Monday through Friday, Eastern Time (GMT -0500) for designated WVDE networking staff. Any costs associated with this requirement are to be included in the line item for technical support on the cost page.

#### **Understood**

The vendor **must** provide a function that permits any user of the WV K-12 network to submit a web site to be reviewed and appropriately categorized by the vendor. This function allows the vendor to receive feedback with the intent of improving delivery of services or product functionality.

**That function is provided by the solution.**

**Section V - Vendor Response**

The vendor is to complete the Cost Worksheet.

The vendor must provide evidence of at least one current, successful installation of the Internet filtering solution in a network configuration servicing 70,000 or more computers with 3 gigabits/second or more of Internet bandwidth. Use the following table.

Project Name	# of computers filtered	Internet bandwidth
<b>Pinellas ISD – Largo Fla.</b>	<b>75,000</b>	<b>3 gigabits/second</b>
<b>24<sup>th</sup> largest school district in US</b>		

If the vendor fails to identify any costs that are required to meet the terms, requirements and conditions of this Quotation, it **shall** be the responsibility of the successful vendor to pay those costs and such costs will not be passed on to the WVDE or the State of West Virginia.

**Understood**

Pricing **must** be stated on the basis of one-year contracts.

Note - Pricing is submitted for 1, 2 and 3 year licenses.

The actual number of licenses purchased may vary from year to year. The quantities of computers listed on the Cost Worksheets are estimates only. The actual quantity to be purchased will be specified in a purchase order.

**Understood**

Filtering licensing prices **must** be quoted based on the number of computers filtered annually so that the WVDE can determine the basis of the pricing submitted in the quote.

**Pricing has been submitted using the required specification. In addition, a blanket price as an option will give you unlimited license use through term of the contract if desired.**

Software updates/upgrades and technical support **must** be priced on an annual basis and this item is reflected as such on the cost page.

**Understood**

The vendor is responsible for any costs due to product end of life that will require replacement or upgrading of the vendor provided software or hardware during the term of the contract.

**Understood**

**Section VI - Cost Evaluation**

All quotes **shall** be all inclusive. No separate reimbursements will be made for travel or any other expense.

**Understood**

The State intends to award the bid to the vendor with the lowest grand total costs to provide a complete Internet filtering solution, including software, filtering updates, licensing, technical support and maintenance according to the specifications. As previously explained, the vendor may also include servers in the bid if the filtering solution cannot meet the requirements of this RFQ when installed on the WVDE equipment identified in Section I – Current Environment.

**Understood**

The WVDE reserves the right to purchase in part or in whole any products and services offered by the vendor in the response to this RFQ. The actual number of licenses purchased each year will be based on a count of computers, provided by the WVDE, on the date of the annual contract renewals.

**Understood**

## Cost Worksheet

Item	Vendor Description	Quantity	Unit Cost	Total Cost	Note
Annual software cost for Filtering Servers.*	NA-Included in License cost	NA-Included in License cost	NA-Included in License cost	NA-Included in License cost	NA-Included in License cost
Annual software cost for Reporting Servers.*	NA-Included in License cost	NA-Included License cost	NA-Included License cost	NA-Included License cost	NA-Included License cost
Annual License for filtering of client computers on K-12 network.		130,000	\$1.81 -or- \$235,300 1 year – unlimited licenses	\$235,300 -or- \$235,300 1 year – unlimited licenses	Your choice on how to purchase node licenses
Annual License for mobile computers. (see note 1 below.)		10,000	\$3.50 -or- \$35,000 1 year – unlimited licenses	\$35,000 -or- \$35,000 1 year – unlimited licenses	Your choice on how to purchase node licenses
Technical support and upgrades/updates for filtering solution	24/7 Technical Support	1 year	\$4,995	\$4,995	
One Day onsite training, 6 hours. Charleston WV (see note 2 below)		1 day	\$5560	\$5,560	Max 6 Students. Covers Composer and Conductor
Onsite installation, Charleston and Morgantown, WV (see note 2 below)		4 days	\$ 12,000	\$12,000	Price includes T&E
Filtering Servers (if required)*	NA	NA	NA	NA	NA
Reporting Servers (if required)*	NA	NA	NA	NA	NA
Other Hardware (if required)*		9 - Devices	\$43,000	\$387,000	Composer Appliances
Hourly rate for custom system modifications	Included with Onsite Installation, Training and Support	20 hours	Included with Onsite Installation, Training and Support	Included with Onsite Installation, Training and Support	
<b>Total Costs</b>				<b>\$ 679,855</b>	

**Note 1:** A mobile computer requires special client software that will force the computer to be filtered even when it is disconnected from the K-12 network and connected to any other network which provides Internet access. If there is no price difference for mobile computers, enter the same unit cost as for computers on the K-12 network.

**Note 2:** Costs for training and installation, configuration and testing **must** inclusive of all incidental costs. Travel expenses, training materials and other reimbursable expenses will not be paid separately. The distance between Charleston and Morgantown WV is approximately 180 miles.



**Item Pricing:**

This worksheet is for vendors to identify items, quantities and provide prices. The vendor should indicate "No Cost" or "N/A" in the appropriate cells or blanks of the cost worksheet for which there are no separate or applicable costs. Any cost area that is left blank will be assumed to be "No Cost." The vendor may add notes to explain or clarify the bid.

\* Vendor is encouraged to provide unit pricing for each of these items. However, it shall be the responsibility of the vendor to determine sufficient quantities needed for the scope of work outlined in the RFQ. For example, the quantity of servers needed to provide coverage for the WVDE's network may be set at one for vendor A, but be determined to be 5 by vendor B, due to design efficiencies.

# Attachment A

## West Virginia Department of Education K-12 State Network Logical Data Flow

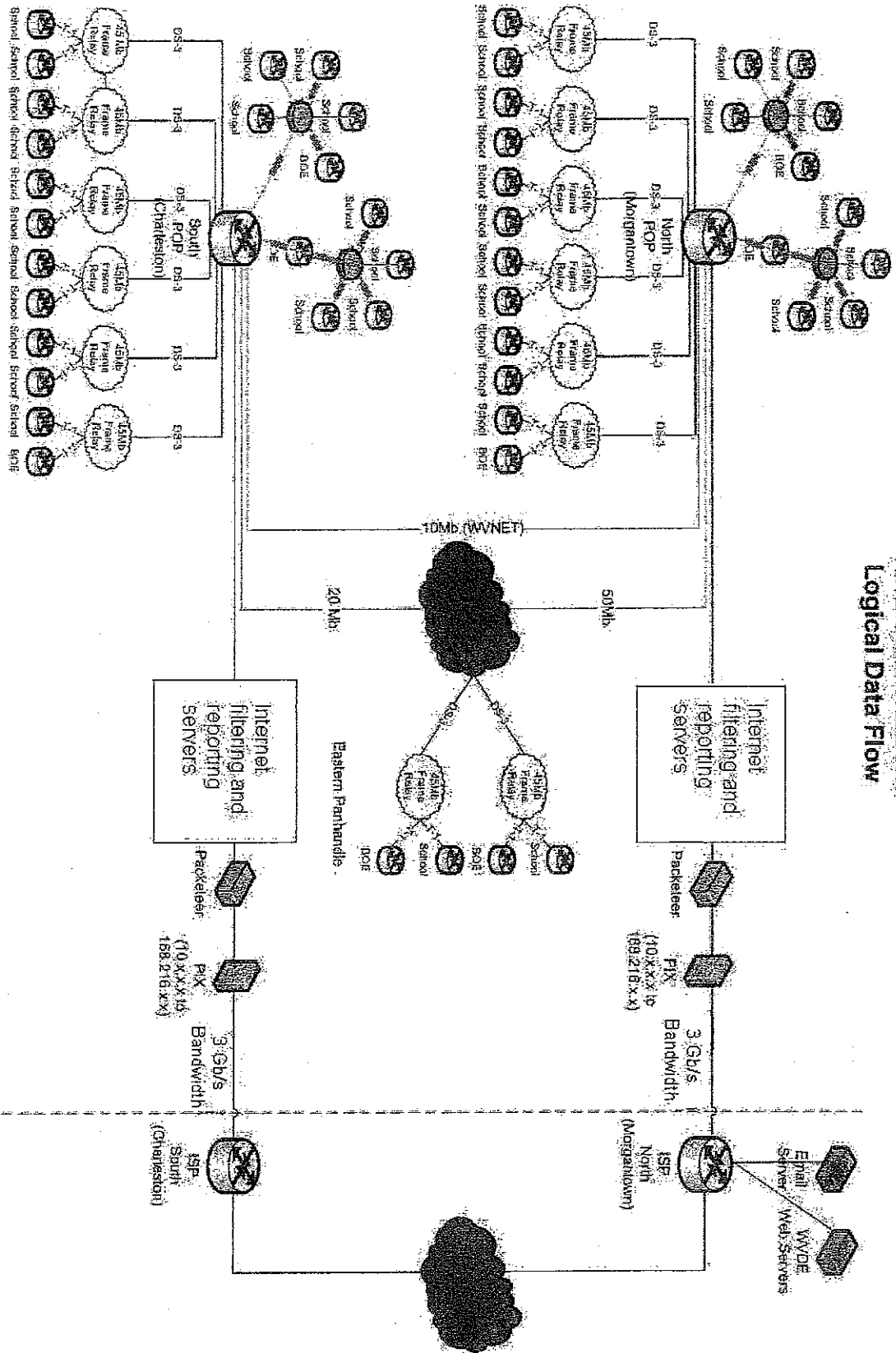



May 17, 2010

Bridge Information Technology  
Attn: Stewart Varney  
586 Tallwood Road  
Huntington, WV 25705

**Letter of authorization**

This letter will serve as confirmation that Bridge Information Technology is a Certified Cymphonix Partner and is authorized to sell Cymphonix solutions throughout the United States in accordance with the Partner and Sales Agreement that is place between Cymphonix and Bridge Information Technology.

Please direct any questions to your Cymphonix Representative.

Best Regards,

Dave Reardon  
Vice President of Sales  
Cymphonix, Inc.

State of West Virginia  
**VENDOR PREFERENCE CERTIFICATE**

Certification and application\* is hereby made for Preference in accordance with *West Virginia Code*, §5A-3-37. (Does not apply to construction contracts). *West Virginia Code*, §5A-3-37, provides an opportunity for qualifying vendors to request (at the time of bid) preference for their residency status. Such preference is an evaluation method only and will be applied only to the cost bid in accordance with the *West Virginia Code*. This certificate for application is to be used to request such preference. The Purchasing Division will make the determination of the Resident Vendor Preference, if applicable.

1. **Application is made for 2.5% resident vendor preference for the reason checked:**  
 Bidder is an individual resident vendor and has resided continuously in West Virginia for four (4) years immediately preceding the date of this certification; or,  
 Bidder is a partnership, association or corporation resident vendor and has maintained its headquarters or principal place of business continuously in West Virginia for four (4) years immediately preceding the date of this certification; or 80% of the ownership interest of Bidder is held by another individual, partnership, association or corporation resident vendor who has maintained its headquarters or principal place of business continuously in West Virginia for four (4) years immediately preceding the date of this certification; or,  
 Bidder is a nonresident vendor which has an affiliate or subsidiary which employs a minimum of one hundred state residents and which has maintained its headquarters or principal place of business within West Virginia continuously for the four (4) years immediately preceding the date of this certification; or,
2. **Application is made for 2.5% resident vendor preference for the reason checked:**  
 Bidder is a resident vendor who certifies that, during the life of the contract, on average at least 75% of the employees working on the project being bid are residents of West Virginia who have resided in the state continuously for the two years immediately preceding submission of this bid; or,
3. **Application is made for 2.5% resident vendor preference for the reason checked:**  
 Bidder is a nonresident vendor employing a minimum of one hundred state residents or is a nonresident vendor with an affiliate or subsidiary which maintains its headquarters or principal place of business within West Virginia employing a minimum of one hundred state residents who certifies that, during the life of the contract, on average at least 75% of the employees or Bidder's affiliate's or subsidiary's employees are residents of West Virginia who have resided in the state continuously for the two years immediately preceding submission of this bid; or,
4. **Application is made for 5% resident vendor preference for the reason checked:**  
 Bidder meets either the requirement of both subdivisions (1) and (2) or subdivision (1) and (3) as stated above; or,
5. **Application is made for 3.5% resident vendor preference who is a veteran for the reason checked:**  
 Bidder is an individual resident vendor who is a veteran of the United States armed forces, the reserves or the National Guard and has resided in West Virginia continuously for the four years immediately preceding the date on which the bid is submitted; or,
6. **Application is made for 3.5% resident vendor preference who is a veteran for the reason checked:**  
 Bidder is a resident vendor who is a veteran of the United States armed forces, the reserves or the National Guard, if, for purposes of producing or distributing the commodities or completing the project which is the subject of the vendor's bid and continuously over the entire term of the project, on average at least seventy-five percent of the vendor's employees are residents of West Virginia who have resided in the state continuously for the two immediately preceding years.

Bidder understands if the Secretary of Revenue determines that a Bidder receiving preference has failed to continue to meet the requirements for such preference, the Secretary may order the Director of Purchasing to: (a) reject the bid; or (b) assess a penalty against such Bidder in an amount not to exceed 5% of the bid amount and that such penalty will be paid to the contracting agency or deducted from any unpaid balance on the contract or purchase order.

By submission of this certificate, Bidder agrees to disclose any reasonably requested information to the Purchasing Division and authorizes the Department of Revenue to disclose to the Director of Purchasing appropriate information verifying that Bidder has paid the required business taxes, provided that such information does not contain the amounts of taxes paid nor any other information deemed by the Tax Commissioner to be confidential.

Under penalty of law for false swearing (*West Virginia Code*, §61-5-3), Bidder hereby certifies that this certificate is true and accurate in all respects; and that if a contract is issued to Bidder and if anything contained within this certificate changes during the term of the contract, Bidder will notify the Purchasing Division in writing immediately.

Bidder: \_\_\_\_\_ Signed: \_\_\_\_\_  
 Date: \_\_\_\_\_ Title: \_\_\_\_\_

\*Check any combination of preference consideration(s) indicated above, which you are entitled to receive.

STATE OF WEST VIRGINIA  
Purchasing Division

**PURCHASING AFFIDAVIT**

**West Virginia Code §5A-3-10a states:** No contract or renewal of any contract may be awarded by the state or any of its political subdivisions to any vendor or prospective vendor when the vendor or prospective vendor or a related party to the vendor or prospective vendor is a debtor and the debt owned is an amount greater than one thousand dollars in the aggregate

**DEFINITIONS:**

“Debt” means any assessment, premium, penalty, fine, tax or other amount of money owed to the state or any of its political subdivisions because of a judgment, fine, permit violation, license assessment, defaulted workers’ compensation premium, penalty or other assessment presently delinquent or due and required to be paid to the state or any of its political subdivisions, including any interest or additional penalties accrued thereon.

“Debtor” means any individual, corporation, partnership, association, Limited Liability Company or any other form or business association owing a debt to the state or any of its political subdivisions. “Political subdivision” means any county commission; municipality; county board of education; any instrumentality established by a county or municipality; any separate corporation or instrumentality established by one or more counties or municipalities, as permitted by law; or any public body charged by law with the performance of a government function or whose jurisdiction is coextensive with one or more counties or municipalities. “Related party” means a party, whether an individual, corporation, partnership, association, limited liability company or any other form or business association or other entity whatsoever, related to any vendor by blood, marriage, ownership or contract through which the party has a relationship of ownership or other interest with the vendor so that the party will actually or by effect receive or control a portion of the benefit, profit or other consideration from performance of a vendor contract with the party receiving an amount that meets or exceed five percent of the total contract amount.

**EXCEPTION:** The prohibition of this section does not apply where a vendor has contested any tax administered pursuant to chapter eleven of this code, workers’ compensation premium, permit fee or environmental fee or assessment and the matter has not become final or where the vendor has entered into a payment plan or agreement and the vendor is not in default of any of the provisions of such plan or agreement.

Under penalty of law for false swearing (*West Virginia Code* §61-5-3), it is hereby certified that the vendor affirms and acknowledges the information in this affidavit and is in compliance with the requirements as stated.

**WITNESS THE FOLLOWING SIGNATURE**

Vendor’s Name: Bridge Information Technology

Authorized Signature: Stewart Varney Date: 5-18-2010

State of West Virginia

County of Cabell, to-wit:

Taken, subscribed, and sworn to before me this 18 day of May, 2010.

My Commission expires June 27, 2012.

AFFIX SEAL HERE

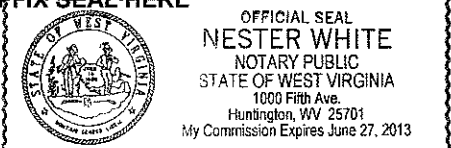

NOTARY PUBLIC [Signature]