

Department of Administration
Purchasing Division
Building 15
2019 Washigton Street East
Charleston, WV 25305
RFQ-DPS1044

We are pleased to respond to your request for pricing for the voting modules.

The areas in the requirements that need to be clarified:

Item:

1.10.1: The requirement calls for less than .5% the product we are proposing is less than 1%

1.12.1. Our components are housed in a 19 inch rack mountable chassis

1.12.3 Racks are not requested therefore we cannot confirm space allocation

2.2 Audio input is -20dbm to +10dbm

3.2 The warranty is 24 months from the date of invoice. Additional warranty is available.

The price for the additional warranty is 3% of the total price, and is for factory limited warranty.

Sincerely,

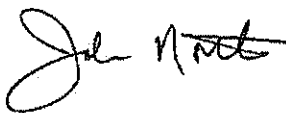

John North
General Manager
Kenwood USA Corporation
Communications Sector-Systems

RECEIVED

2010 JUN 16 A 10:09

PURCHASING DIVISION
STATE OF WV



State of West Virginia
 Department of Administration
 Purchasing Division
 2019 Washington Street East
 Post Office Box 50130
 Charleston, WV 25305-0130

Request for Quotation

RFQ NUMBER
DPS1044

PAGE
1

ADDRESS CORRESPONDENCE TO ATTENTION OF
**KRISTA FERRELL
 304-558-2596**

VENDOR

RFQ COPY
 TYPE NAME/ADDRESS HERE
 Kenwood USA Corporation
 3970 Johns Creek Court
 Suite 100
 Suwanee, GA 30024

SHIP TO

DEPARTMENT OF PUBLIC SAFETY
 4124 KANAWHA TURNPIKE
 SOUTH CHARLESTON, WV
 25309 746-2141

DATE PRINTED	TERMS OF SALE	SHIP VIA	FOB	FREIGHT TERMS
05/19/2010				

BID OPENING DATE: **06/16/2010** BID OPENING TIME **01:30PM**

LINE	QUANTITY	UOP	CAT NO	ITEM NUMBER	UNIT PRICE	AMOUNT
0001	1	LS		725-50	\$ 11,736	\$ 117,360
SIGNAL AND NOISE COMPARATORS REQUEST FOR QUOTATION (RFQ) OPEN END CONTRACT THE WEST VIRGINIA STATE PURCHASING DIVISION FOR THE AGENCY, THE WEST VIRGINIA STATE POLICE, IS SOLICITING BIDS TO PROVIDE THE AGENCY WITH AN OPEN END CONTRACT FOR SIGNAL AND NOISE COMPARATORS AND RELATED ACCESSORIES PER THE ATTACHED SPECIFICATIONS. TECHNICAL QUESTIONS CONCERNING THIS SOLICITATION MUST BE SUBMITTED IN WRITING TO KRISTA FERRELL IN THE WEST VIRGINIA STATE PURCHASING DIVISION VIA MAIL AT THE ADDRESS SHOWN IN THE BODY OF THIS RFQ, VIA FAX AT 304-558-4115, OR VIA EMAIL AT KRISTA.S.FERRELL@WV.GOV. DEADLINE FOR ALL TECHNICAL QUESTIONS IS 06/03/2010 AT THE CLOSE OF BUSINESS. ANY TECHNICAL QUESTIONS RECEIVED WILL BE ANSWERED BY FORMAL ADDENDUM ISSUED BY THE PURCHASING DIVISION AFTER THE DEADLINE HAS LAPSED. EXHIBIT 10 REQUISITION NO.: ADDENDUM ACKNOWLEDGEMENT I HEREBY ACKNOWLEDGE RECEIPT OF THE FOLLOWING CHECKED						

SEE REVERSE SIDE FOR TERMS AND CONDITIONS

SIGNATURE <i>Joe M...</i>	TELEPHONE 678-474-4700	DATE 6-15-10
TITLE General Manager	FEN 015-2948901	ADDRESS CHANGES TO BE NOTED ABOVE

WHEN RESPONDING TO RFQ, INSERT NAME AND ADDRESS IN SPACE ABOVE LABELED 'VENDOR'



State of West Virginia
 Department of Administration
 Purchasing Division
 2019 Washington Street East
 Post Office Box 50130
 Charleston, WV 25305-0130

Request for Quotation

RFQ NUMBER
DPS1044

PAGE
2

ADDRESS CORRESPONDENCE TO ATTENTION OF
**KRISTA FERRELL
 304-558-2596**

VENDOR

RFQ COPY
TYPE NAME/ADDRESS HERE
 Kenwood USA Corporation
 3970 Johns Creek Court
 Suite 100
 Suwanee, GA 30024

SHIP TO

DEPARTMENT OF PUBLIC SAFETY
 4124 KANAWHA TURNPIKE

 SOUTH CHARLESTON, WV
 25309 746-2141

DATE PRINTED	TERMS OF SALE	SHIP VIA	F.O.B.	FREIGHT TERMS
05/19/2010				

BID OPENING DATE: **06/16/2010** BID OPENING TIME **01:30PM**

LINE	QUANTITY	UOP	CAT NO	ITEM NUMBER	UNIT PRICE	AMOUNT
<p>ADDENDUM(S) AND HAVE MADE THE NECESSARY REVISIONS TO MY PROPOSAL, PLANS AND/OR SPECIFICATION, ETC.</p> <p>ADDENDUM NO.'S:</p> <p>NO. 1</p> <p>NO. 2</p> <p>NO. 3</p> <p>NO. 4</p> <p>NO. 5</p> <p>I UNDERSTAND THAT FAILURE TO CONFIRM THE RECEIPT OF THE ADDENDUM(S) MAY BE CAUSE FOR REJECTION OF BIDS.</p> <p>VENDOR MUST CLEARLY UNDERSTAND THAT ANY VERBAL REPRESENTATION MADE OR ASSUMED TO BE MADE DURING ANY ORAL DISCUSSION HELD BETWEEN VENDOR'S REPRESENTATIVES AND ANY STATE PERSONNEL IS NOT BINDING. ONLY THE INFORMATION ISSUED IN WRITING AND ADDED TO THE SPECIFICATIONS BY AN OFFICIAL ADDENDUM IS BINDING.</p> <p>.....<i>John W. ...</i>..... SIGNATURE KENWOOD USA CORP..... COMPANY 6/14/10..... DATE</p>						

SEE REVERSE SIDE FOR TERMS AND CONDITIONS

SIGNATURE <i>John W. ...</i>	TELEPHONE 678-474-4700	DATE 6-14-10
TITLE General MANAGER	ADDRESS CHANGES TO BE NOTED ABOVE	

WHEN RESPONDING TO RFQ, INSERT NAME AND ADDRESS IN SPACE ABOVE LABELED 'VENDOR'



State of West Virginia
 Department of Administration
 Purchasing Division
 2019 Washington Street East
 Post Office Box 50130
 Charleston, WV 25305-0130

Request for Quotation

RFQ NUMBER
DPS1044

PAGE
3

ADDRESS CORRESPONDENCE TO ATTENTION OF
**KRISTA FERRELL
 304-558-2596**

VENDOR

RFQ COPY
 TYPE NAME/ADDRESS HERE
 Kenwood USA Corporation
 3970 Johns Creek Court
 Suite 100
 Suwanee, GA 30024

SHIP TO

DEPARTMENT OF PUBLIC SAFETY
 4124 KANAWHA TURNPIKE
 SOUTH CHARLESTON, WV
 25309 746-2141

DATE PRINTED	TERMS OF SALE	SHIP VIA	F.O.B.	FREIGHT TERMS
05/19/2010				

BID OPENING DATE: **06/16/2010** BID OPENING TIME **01:30PM**

LINE	QUANTITY	UOP	CAT. NO.	ITEM NUMBER	UNIT PRICE	AMOUNT
<p>NOTE: THIS ADDENDUM ACKNOWLEDGEMENT SHOULD BE SUBMITTED WITH THE BID.</p> <p>REV. 09/21/2009</p> <p>EXHIBIT 3</p> <p>LIFE OF CONTRACT: THIS CONTRACT BECOMES EFFECTIVE ON AWARD AND EXTENDS FOR A PERIOD OF ONE (1) YEAR OR UNTIL SUCH "REASONABLE TIME" THEREAFTER AS IS NECESSARY TO OBTAIN A NEW CONTRACT OR RENEW THE ORIGINAL CONTRACT. THE "REASONABLE TIME" PERIOD SHALL NOT EXCEED TWELVE (12) MONTHS. DURING THIS "REASONABLE TIME" THE VENDOR MAY TERMINATE THIS CONTRACT FOR ANY REASON UPON GIVING THE DIRECTOR OF PURCHASING 30 DAYS WRITTEN NOTICE.</p> <p>UNLESS SPECIFIC PROVISIONS ARE STIPULATED ELSEWHERE IN THIS CONTRACT DOCUMENT, THE TERMS, CONDITIONS AND PRICING SET HEREIN ARE FIRM FOR THE LIFE OF THE CONTRACT.</p> <p>RENEWAL: THIS CONTRACT MAY BE RENEWED UPON THE MUTUAL WRITTEN CONSENT OF THE SPENDING UNIT AND VENDOR, SUBMITTED TO THE DIRECTOR OF PURCHASING THIRTY (30) DAYS PRIOR TO THE EXPIRATION DATE. SUCH RENEWAL SHALL BE IN ACCORDANCE WITH THE TERMS AND CONDITIONS OF THE ORIGINAL CONTRACT AND SHALL BE LIMITED TO TWO (2) ONE (1) YEAR PERIODS.</p> <p>CANCELLATION: THE DIRECTOR OF PURCHASING RESERVES THE RIGHT TO CANCEL THIS CONTRACT IMMEDIATELY UPON WRITTEN NOTICE TO THE VENDOR IF THE COMMODITIES AND/OR SERVICES SUPPLIED ARE OF AN INFERIOR QUALITY OR DO NOT CONFORM TO THE SPECIFICATIONS OF THE BID AND CONTRACT HEREIN.</p>						

SEE REVERSE SIDE FOR TERMS AND CONDITIONS

SIGNATURE <i>John Noster</i>	TELEPHONE 678-474-4700	DATE 6-15-10
TITLE GENERAL MANAGER	FEIN 95-2948901	ADDRESS CHANGES TO BE NOTED ABOVE

WHEN RESPONDING TO RFQ, INSERT NAME AND ADDRESS IN SPACE ABOVE LABELED 'VENDOR'



State of West Virginia
 Department of Administration
 Purchasing Division
 2019 Washington Street East
 Post Office Box 50130
 Charleston, WV 25305-0130

Request for Quotation

RFQ NUMBER:
DPS1044

PAGE:
4

ADDRESS CORRESPONDENCE TO ATTENTION OF:
**KRISTA FERRELL
 304-558-2596**

VENDOR

RFQ COPY
TYPE NAME/ADDRESS HERE
 Kenwood USA Corporation
 3970 Johns Creek Court
 Suite 100
 Suwanee, GA 30024

SHIP TO

DEPARTMENT OF PUBLIC SAFETY
 4124 KANAWHA TURNPIKE
 SOUTH CHARLESTON, WV
 25309 746-2141

DATE PRINTED	TERMS OF SALE	SHIP VIA	F.O.B.	FREIGHT TERMS
05/19/2010				
BID OPENING DATE: 06/16/2010		BID OPENING TIME 01:30PM		

LINE	QUANTITY	UOP	CAT NO	ITEM NUMBER	UNIT PRICE	AMOUNT
<p>OPEN MARKET CLAUSE: THE DIRECTOR OF PURCHASING MAY AUTHORIZE A SPENDING UNIT TO PURCHASE ON THE OPEN MARKET, WITHOUT THE FILING OF A REQUISITION OR COST ESTIMATE, ITEMS SPECIFIED ON THIS CONTRACT FOR IMMEDIATE DELIVERY IN EMERGENCIES DUE TO UNFORESEEN CAUSES (INCLUDING BUT NOT LIMITED TO DELAYS IN TRANSPORTATION OR AN UNANTICIPATED INCREASE IN THE VOLUME OF WORK.)</p> <p>QUANTITIES: QUANTITIES LISTED IN THE REQUISITION ARE APPROXIMATIONS ONLY, BASED ON ESTIMATES SUPPLIED BY THE STATE SPENDING UNIT. IT IS UNDERSTOOD AND AGREED THAT THE CONTRACT SHALL COVER THE QUANTITIES ACTUALLY ORDERED FOR DELIVERY DURING THE TERM OF THE CONTRACT, WHETHER MORE OR LESS THAN THE QUANTITIES SHOWN.</p> <p>ORDERING PROCEDURE: SPENDING UNIT(S) SHALL ISSUE A WRITTEN STATE CONTRACT ORDER (FORM NUMBER WV-39) TO THE VENDOR FOR COMMODITIES COVERED BY THIS CONTRACT. THE ORIGINAL COPY OF THE WV-39 SHALL BE MAILED TO THE VENDOR AS AUTHORIZATION FOR SHIPMENT, A SECOND COPY MAILED TO THE PURCHASING DIVISION, AND A THIRD COPY RETAINED BY THE SPENDING UNIT.</p> <p>BANKRUPTCY: IN THE EVENT THE VENDOR/CONTRACTOR FILES FOR BANKRUPTCY PROTECTION, THE STATE MAY DEEM THE CONTRACT NULL AND VOID, AND TERMINATE SUCH CONTRACT WITHOUT FURTHER ORDER.</p> <p>THE TERMS AND CONDITIONS CONTAINED IN THIS CONTRACT SHALL SUPERSEDE ANY AND ALL SUBSEQUENT TERMS AND CONDITIONS WHICH MAY APPEAR ON ANY ATTACHED PRINTED DOCUMENTS SUCH AS PRICE LISTS, ORDER FORMS, SALES AGREEMENTS OR MAINTENANCE AGREEMENTS, INCLUDING ANY ELECTRONIC MEDIUM SUCH AS CD-ROM.</p>						

SEE REVERSE SIDE FOR TERMS AND CONDITIONS

SIGNATURE <i>[Signature]</i>	TELEPHONE 678-474-4700	DATE 6-15-10
TITLE General Manager	FEIN 95-2948901	ADDRESS CHANGES TO BE NOTED ABOVE

WHEN RESPONDING TO RFQ, INSERT NAME AND ADDRESS IN SPACE ABOVE LABELED 'VENDOR'



State of West Virginia
 Department of Administration
 Purchasing Division
 2019 Washington Street East
 Post Office Box 50130
 Charleston, WV 25305-0130

Request for Quotation

RFQ NUMBER
DPS1044

PAGE
5

ADDRESS CORRESPONDENCE TO ATTENTION OF
**KRISTA FERRELL
 304-558-2596**

RFQ COPY

TYPE NAME/ADDRESS HERE
 Kenwood USA Corporation
 3970 Johns Creek Court
 Suite 100
 Suwanee, GA 30024

SHIP TO

DEPARTMENT OF PUBLIC SAFETY
 4124 KANAWHA TURNPIKE
 SOUTH CHARLESTON, WV
 25309 746-2141

DATE PRINTED	TERMS OF SALE	SHIP VIA	F.O.B.	FREIGHT TERMS
05/19/2010				

BID OPENING DATE: **06/16/2010** BID OPENING TIME **01:30PM**

LINE	QUANTITY	UOP	CAT. NO.	ITEM NUMBER	UNIT PRICE	AMOUNT
<p>REV. 05/26/2009</p> <p>EXHIBIT 4</p> <p>LOCAL GOVERNMENT BODIES: UNLESS THE VENDOR INDICATES IN THE BID HIS REFUSAL TO EXTEND THE PRICES, TERMS, AND CONDITIONS OF THE BID TO COUNTY, SCHOOL, MUNICIPAL AND OTHER LOCAL GOVERNMENT BODIES, THE BID SHALL EXTEND TO POLITICAL SUBDIVISIONS OF THE STATE OF WEST VIRGINIA. IF THE VENDOR DOES NOT WISH TO EXTEND THE PRICES, TERMS, AND CONDITIONS OF THE BID TO ALL POLITICAL SUBDIVISIONS OF THE STATE, THE VENDOR MUST CLEARLY INDICATE SUCH REFUSAL IN HIS BID. SUCH REFUSAL SHALL NOT PREJUDICE THE AWARD OF THIS CONTRACT IN ANY MANNER.</p> <p>REV. 3/88</p> <p>PURCHASING CARD ACCEPTANCE: THE STATE OF WEST VIRGINIA CURRENTLY UTILIZES A VISA PURCHASING CARD PROGRAM WHICH IS ISSUED THROUGH A BANK. THE SUCCESSFUL VENDOR MUST ACCEPT THE STATE OF WEST VIRGINIA VISA PURCHASING CARD FOR PAYMENT OF ALL ORDERS PLACED BY ANY STATE AGENCY AS A CONDITION OF AWARD.</p> <p style="text-align: center;">NOTICE</p> <p>A SIGNED BID MUST BE SUBMITTED TO:</p> <p style="text-align: center;">DEPARTMENT OF ADMINISTRATION PURCHASING DIVISION BUILDING 15 2019 WASHINGTON STREET, EAST CHARLESTON, WV 25305-0130</p>						

SEE REVERSE SIDE FOR TERMS AND CONDITIONS

SIGNATURE <i>John M...</i>	TELEPHONE 678-474-4700	DATE 6-15-10
TITLE General Manager	FEN 95-2948901	ADDRESS CHANGES TO BE NOTED ABOVE

WHEN RESPONDING TO RFQ, INSERT NAME AND ADDRESS IN SPACE ABOVE LABELED 'VENDOR'



State of West Virginia
 Department of Administration
 Purchasing Division
 2019 Washington Street East
 Post Office Box 50130
 Charleston, WV 25305-0130

Request for Quotation

RFQ NUMBER
DPS1044

PAGE
6

ADDRESS CORRESPONDENCE TO ATTENTION OF:
**KRISTA FERRELL
 304-558-2596**

VENDOR

RFQ COPY
TYPE NAME/ADDRESS HERE
 Kenwood USA Corporation
 3970 Johns Creek Court
 Suite 100
 Suwanee, GA 30024

SHIP TO

**DEPARTMENT OF PUBLIC SAFETY
 4124 KANAWHA TURNPIKE
 SOUTH CHARLESTON, WV
 25309 746-2141**

DATE PRINTED	TERMS OF SALE	SHIP VIA	FOB	FREIGHT TERMS
05/19/2010				

BID OPENING DATE: **06/16/2010** BID OPENING TIME **01:30PM**

LINE	QUANTITY	UOP	CAT NO	ITEM NUMBER	UNIT PRICE	AMOUNT
<p>THE BID SHOULD CONTAIN THIS INFORMATION ON THE FACE OF THE ENVELOPE OR THE BID MAY NOT BE CONSIDERED:</p> <p>SEALED BID</p> <p>BUYER: KRISTA FERRELL-FILE 21</p> <p>RFQ. NO.: DPS1044</p> <p>BID OPENING DATE: 06/16/2010</p> <p>BID OPENING TIME: 1:30 PM</p> <p>PLEASE PROVIDE A FAX NUMBER IN CASE IT IS NECESSARY TO CONTACT YOU REGARDING YOUR BID: <u>678-957-1880</u></p> <p>CONTACT PERSON (PLEASE PRINT CLEARLY): <u>John North</u></p>						

SEE REVERSE SIDE FOR TERMS AND CONDITIONS

SIGNATURE <i>John North</i>	TELEPHONE <i>678-474-4700</i>	DATE <i>6-15-10</i>
TITLE <i>General Manager</i> FEIN <i>95-2948901</i>	ADDRESS CHANGES TO BE NOTED ABOVE	

WHEN RESPONDING TO RFQ, INSERT NAME AND ADDRESS IN SPACE ABOVE LABELED 'VENDOR'

Signal to Noise Voter Comparator

The West Virginia State Police desire to establish an open-end contract for the purchase of Signal and Noise Voter Comparators, related accessories, and options. The contract shall be available for use by all other entities of state government, as well as counties and municipalities as this will assist in the State's Interoperable Radio Project.

	Comply?	
	Yes	No
1. <u>Signal to Noise Voter Comparator</u>		
1.1 Voting shall be accomplished by a signal to noise comparison of received signal.	X	
1.2 Voter shall have a capacity of 8 channels, expandable to at least 12 channels.	X	
1.3 Voting shall take place continuously.	X	
1.4 Voting criteria will be as little as 2db difference between channels.	X	
1.5 Audio input level shall be between 100 mv and 10 V p-p.		X
1.6 Each channel shall display visual indication of:		
1.6.1 Channel Active	X	
1.6.2 Channel Voted	X	
1.7 Each channel should display visual indication of:		
1.7.1 Channel Failed	X	
1.8 Each channel shall be capable of being disabled independently of others.	X	
1.8.1 Manual selection shall be by way of a toggle switch on the front panel of unit	X	

	Comply?	
	Yes	No
1.8.2 Manual (forced) selection shall be reflected by a visual indication.	<u>X</u>	_____
1.9 Each channel shall be independently selectable forcing voting to occur on that channel until manually deselected.	<u>X</u>	_____
1.9.1 Manual selection shall be by way of a toggle switch on the front panel of unit	<u>X</u>	_____
1.9.2 Manual (forced) selection shall be reflected by a visual indication.	<u>X</u>	_____
1.10 Audio output shall be up to 1v p-p and adjustable.	<u>X</u>	_____
1.10.1 Distortion shall be less than 0.5% at rated output <u>LESS THAN 1%</u>	_____	<u>X</u>
1.11 Each channel shall be individually adjustable.	<u>X</u>	_____
1.12 Mounting		
1.12.1 All components will be contained in a 19" rack. <u>COMPONENTS ARE RACK MOUNTABLE IN A 19" CHASSIS</u>	_____	<u>X</u>
1.12.2 Boards will plug into a back plane	<u>X</u>	_____
1.12.3 Space will be allocated in the rack for a power supply module as required. <u>RACK IS NOT PROVIDED</u>	_____	<u>X</u>
1.13 Power Supply		
1.13.1 Power supply will operate from 110v line input	<u>X</u>	_____
1.13.2 Modules will operate from +11 to +15 Volts DC provided by power supply in 1.13	<u>X</u>	_____
<u>2.0 Receiver Interface</u>		
2.1 Remotely mounted receivers shall utilize an interface module to provide COR indication over phone or radio interface. This may utilize pilot tones of either 1950 Hz or 2175 Hz.	<u>X</u>	_____
2.2 Audio output from this device shall be from -30 to +10dbm <u>AUDIO INPUT IS -30 TO +10 dBm</u>	_____	<u>X</u>
2.3 One receiver interface shall be provided for each voter channel.	<u>X</u>	_____

	Comply?	
	Yes	No
3.0 General Specifications and Warranty		
3.1 Upon request and/or prior to bid award vendors shall provide manufacturer's certification indicating they are an authorized reseller of the product(s) they are offering/bidding.	X	
3.2 All equipment shall be warranted for a period of 3 years, including parts and labor, and beginning when the equipment is first placed in service.		X
3.3 Each item bid should include make and model on Attachment II: Equipment List.	X	
3.4 All pricing should be line itemed as indicated on Attachment I: Cost Sheet.	X	
3.5 Special / Promotional pricing offered by vendors for limited periods of time and any item pricing provided for items not requested in this RFQ shall not be considered for bid award and/or price comparison.	X	

RFQ# DPS 1044
VHF and UHF Digital Mobile Radio
Attachment I: Cost Sheet

The vendor must provide pricing inclusive of all associated costs for the following items including the cost of delivery. The estimated quantities contained on the cost sheet are intended for bid evaluation purposes only. Actual quantities may vary based upon the needs of the agency. Vendors should complete this pricing sheet in lieu of submission of manufacturer's quotes.

Item No.	Description	Unit Cost	Estimated Qty.	Extended Cost
1	Signal to Noise Voter Comparator	\$5,136.00	10	\$51,360.00
2	Receiver Interface Module	\$1,410.00	10	\$14,100.00
3	Expansion Module (4 channel minimum)	\$5,190.00	10	\$51,900.00
Total Bid:				\$117,360.00

RFQ# DPS 1044

Signal to Noise Voter Comparator
Attachment II: Equipment List

Vendor must provide manufacturer, model number, and part number for the all equipment bid. Vendors should include with their bid, a copy of the manufacturer's product sheet and any other supporting documentation which demonstrates the vendor's adherence to the mandatory specifications as outlined in the specifications.

Item No.	Description	Manufacturer	Model Number	Part Number
1	Signal to Noise Comparator	RAYTHEON	SNV-12	5951-8000
2	Receiver interface module	RAYTHEON	SVM-2	5952-112000
3	Expansion Module (4 channel minimum)	RAYTHEON	SNV-12	5951-8000

VENDOR PREFERENCE CERTIFICATE

Certification and application* is hereby made for Preference in accordance with West Virginia Code, §5A-3-37. (Does not apply to construction contracts). West Virginia Code, §5A-3-37, provides an opportunity for qualifying vendors to request (at the time of bid) preference for their residency status. Such preference is an evaluation method only and will be applied only to the cost bid in accordance with the West Virginia Code. This certificate for application is to be used to request such preference. The Purchasing Division will make the determination of the Resident Vendor Preference, if applicable.

- 1. Application is made for 2.5% resident vendor preference for the reason checked: Bidder is an individual resident vendor and has resided continuously in West Virginia for four (4) years immediately preceding the date of this certification; or, Bidder is a partnership, association or corporation resident vendor and has maintained its headquarters or principal place of business continuously in West Virginia for four (4) years immediately preceding the date of this certification; or 80% of the ownership interest of Bidder is held by another individual, partnership, association or corporation resident vendor who has maintained its headquarters or principal place of business continuously in West Virginia for four (4) years immediately preceding the date of this certification; or, Bidder is a nonresident vendor which has an affiliate or subsidiary which employs a minimum of one hundred state residents and which has maintained its headquarters or principal place of business within West Virginia continuously for the four (4) years immediately preceding the date of this certification; or,
2. Application is made for 2.5% resident vendor preference for the reason checked: Bidder is a resident vendor who certifies that, during the life of the contract, on average at least 75% of the employees working on the project being bid are residents of West Virginia who have resided in the state continuously for the two years immediately preceding submission of this bid; or,
3. Application is made for 2.5% resident vendor preference for the reason checked: Bidder is a nonresident vendor employing a minimum of one hundred state residents or is a nonresident vendor with an affiliate or subsidiary which maintains its headquarters or principal place of business within West Virginia employing a minimum of one hundred state residents who certifies that, during the life of the contract, on average at least 75% of the employees or Bidder's affiliate's or subsidiary's employees are residents of West Virginia who have resided in the state continuously for the two years immediately preceding submission of this bid; or,
4. Application is made for 5% resident vendor preference for the reason checked: Bidder meets either the requirement of both subdivisions (1) and (2) or subdivision (1) and (3) as stated above; or,
5. Application is made for 3.5% resident vendor preference who is a veteran for the reason checked: Bidder is an individual resident vendor who is a veteran of the United States armed forces, the reserves or the National Guard and has resided in West Virginia continuously for the four years immediately preceding the date on which the bid is submitted; or,
6. Application is made for 3.5% resident vendor preference who is a veteran for the reason checked: Bidder is a resident vendor who is a veteran of the United States armed forces, the reserves or the National Guard, if, for purposes of producing or distributing the commodities or completing the project which is the subject of the vendor's bid and continuously over the entire term of the project, on average at least seventy-five percent of the vendor's employees are residents of West Virginia who have resided in the state continuously for the two immediately preceding years.

Bidder understands if the Secretary of Revenue determines that a Bidder receiving preference has failed to continue to meet the requirements for such preference, the Secretary may order the Director of Purchasing to: (a) reject the bid; or (b) assess a penalty against such Bidder in an amount not to exceed 5% of the bid amount and that such penalty will be paid to the contracting agency or deducted from any unpaid balance on the contract or purchase order.

By submission of this certificate, Bidder agrees to disclose any reasonably requested information to the Purchasing Division and authorizes the Department of Revenue to disclose to the Director of Purchasing appropriate information verifying that Bidder has paid the required business taxes, provided that such information does not contain the amounts of taxes paid nor any other information deemed by the Tax Commissioner to be confidential.

Under penalty of law for false swearing (West Virginia Code, §61-5-3), Bidder hereby certifies that this certificate is true and accurate in all respects; and that if a contract is issued to Bidder and if anything contained within this certificate changes during the term of the contract, Bidder will notify the Purchasing Division in writing immediately.

Bidder: _____ Signed: _____

Date: _____ Title: _____

*Check any combination of preference consideration(s) indicated above, which you are entitled to receive.

SNV-12 Signal-and-Noise Voter Comparator

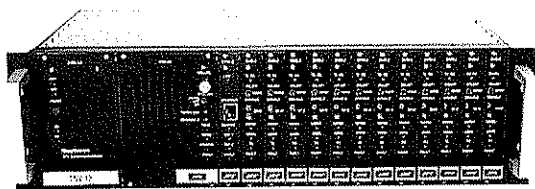

The SNV-12 modular receiver voting system uses individual Digital Signal Processing (DSP) channels to measure the quality of received signal for fast and accurate determination of the best signal. The SNV-12 chassis accommodates from 2 to 12 receiver Site Voter Modules and interfaces easily with standard dispatch consoles.

Benefits

- Detects and generates EIA keytones in addition to hard PTT.
- Can repeat voted audio.
- Local control plus IP and serial remote control.
- Automatic and manual transmit steering capability.
- Digital delay ensures no loss of initial syllables.
- System expansion to 36 sites by daisy-chaining multiple SNV-12s.
- 5.25" high by 19" wide rack-mount modular card-cage package.
- System statistics and voted audio monitoring available via IP.
- Dispatcher's transmit audio takes precedence over repeat of voted transmissions, or may be mixed with the repeat audio.

Overview

The SNV-12 uses Digital Signal Processors to continuously monitor multiple remote sites and select the receiver with the best signal quality. One application is a two-way radio application where mobiles and portables can hear a repeater, but due to lower transmit power and/or antenna placement, the repeater can't hear the mobiles and portables. Remote receivers can be positioned in the communications dead spots, with audio from each receiver linked to the voter via microwave, landline, twisted pair, or fiber optics. The voter will select the best quality signal from all remote receivers and forward this signal to the repeater for rebroadcast; providing greater talk back range for radios.

DSP Voting

The Site Voter Module (SVM) uses a spectral approach to continuously measure the

noise or Signal-to-Noise Ratio (SNR) of the audio signal from each receiver site. The signal and noise amplitudes are measured by proprietary speech detection and measurement algorithms. Each SVM continuously measures its receiver signal and calculates a Signal Quality Number in 31 discrete steps. The SNV-12 monitors all SVMs and votes the site with the best Signal Quality Number. The voting process ensures the best site is voted even if the received signal is emanating from a vehicle that is moving behind buildings or between remote voting receiver sites.

The SNV-12 parameters also allow the voter to be set to lock on the initially voted site, which is important in systems where no voted site transitions are desired during any individual field transmission.

The voting process is initiated

whenever any receiver is unswitched. This is signalled either by loss of pilot tone or by a hardwired receiver signal (COR output or multiplexer E-lead); individually configurable on each SVM. The SNV-12 will accept pilot tone frequencies of either 1950 or 2175 Hz, configured by dip-switch.

Transmit Steering

In automatic transmit steering applications, the transmitter associated with the currently voted receiver is used for the dispatcher's reply to the mobile or portable in the field that made the initial call. Manual control capability is also provided, allowing the dispatcher to decide which transmitter site to use for a reply. The voter can also be configured to group multiple voting receivers around individual remote transmitters.

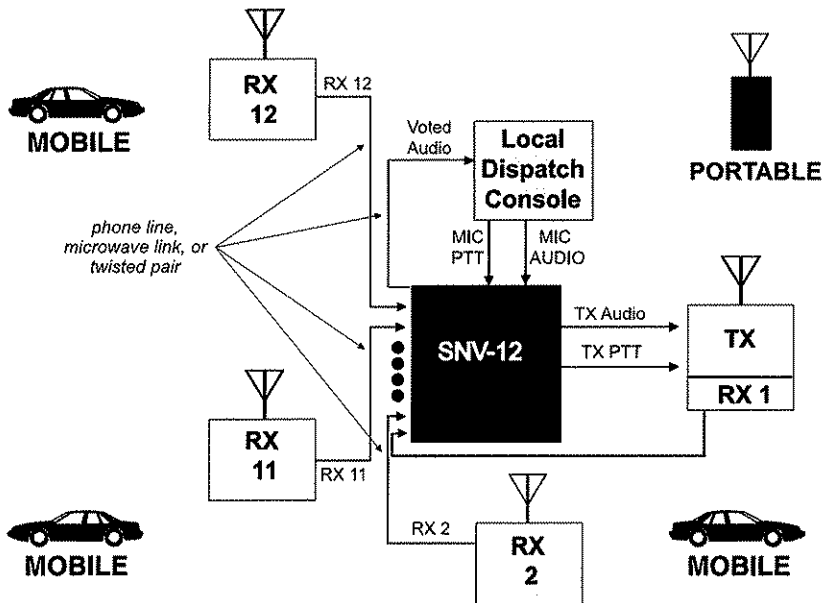

Diagram: Repeater System using the SNV-12 Voter with 12 Receivers.

Site Voter Module Audio Inputs

Radio RX Input: Balanced 600 Ohms or 10k Ohms, unbalanced 10k Ohms.

Input Level: -30 to +10 dBm, adjustable.

Unsquench Indications: 2175Hz pilot tone; 1950 Hz pilot tone; E-Lead input. Optional pilot tone generator accessory, PTG-10, enables the use of any receiver with a COR output.

Voting Audio Output

Output: Balanced 600 Ohms.

Output Level: -20 to +11 dBm, adjustable.

Frequency Response: 200 to 3200 Hz± 2dB. (300 to 3000 Hz ± 1dB).

Keying: EIA Keytones or E&M.

Absolute Output Delay: Less than 10msec.

Voting Comparator

Switching Time Between Sites: Less than 1 msec.

Unselected Output Rejection: Greater than 60 dBm.

Voting Thresholds: 31 steps.

General/Environmental

Site Voter Module Front Panel (SVM-2): Select/Normal/Disable Switch, Voted LED, Unsquenced LED, TX LED, TX Select LED, Fault LED, Norm and Peak input audio level LEDs, test point, and adjustment.

Console Interface Front Panel (CIM-2A): Speaker Off/RX/RX and TX, Volume control, Norm and Peak audio level LEDs, Fault LED, Remote LED, Adjustments for Console TX audio in and Voted audio out.

Serial Port : RS-232 DCE connector (female DB9). Baud rates: 300 - 57,600

Network Interface : RJ-45 Connector; 10/100 Base-T Ethernet, T1 5409A DSP, Ethernet (built in web page), Telnet.

AC Input Power : 115 or 230 VAC ± 15%, 47-63 Hz, 130 VA maximum when "fully loaded".

DC Input Power : +11 to +15 VDC @5A nominal.

Size : 5.25"H x 19"W x 11"D (13.3 x 48.3 x 28 cm).

Temperature : Operating: -20 to +60 degrees C. Storage: -40 to +85 degrees C.

Certifications : TUV, FCC Part 15. Class A.

Raytheon Company
Civil Communications Solutions
 5800 Departure Drive
 Raleigh, NC 27616
 voter.sales@raytheon.com

www.raytheon.com

Raytheon

Customer Success Is Our Mission

PTG-10 Pilot Tone Generator

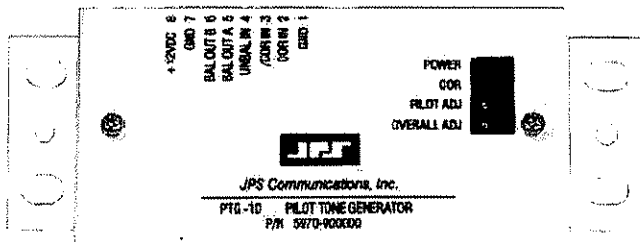

Benefits

- Allows use of low cost receiver in voting system.
- Permits audio and COR to occupy same pair of wires.
- Produces two standard pilot tones: 1950Hz or 2175Hz.
- Insures the integrity of voting receive link.
- Allows voter to ignore faulty receiver site.
- Provides screwdriver type terminal block.
- Operates from +11 to +15 VDC.
- Balanced audio output for long distance link.
- Provides two LEDs: Power and COR.

PTG-10 Overview

In an LMR voting system, receivers are strategically placed around a geographic area (at voting sites) to fill dead spots where portable or mobile radios can not talk to the main repeater site. The audio from each receiver is linked to the voter which continuously compares the signal from all receivers and passes through the best quality signal to the dispatcher, and/or repeater. In this system, it is necessary to transfer a receiver's COR (Carrier Operated Relay) or COS (Carrier Operated Squelch) signal to the voter from a remote receiver site. COR is an indication that the receiver has broken squelch. A COR signal (DC logic) exits the receiver separately from the audio lines (AC signal), making it impossible to carry both on same audio pair. The function of the PTG-10 is to convert the COR

The PTG-10 produces a crystal controlled pilot tone as a means of transferring a COR signal from a remote receiver site to a local site containing a voter or repeater. Use of the PTG-10 transfers the COR signal over the same path as the receive audio, eliminating the need for a second communications path for the COR signal.

logic to a pilot tone and send via the audio lines to the voter; therefore, making a two wire telephone circuit suitable for a remote receiver connection.

System Overview

The PTG-10 produces a crystal controlled pilot tone as a means of transferring a COR signal from a remote receiver site to a local site containing a voter or repeater.

The PTG-10 converts the COR signal to a pilot tone. The pilot tone is injected on the audio lines whenever the associated receiver is squelched, and removes the tone whenever the receiver is unsquelched. When the receiver used in the voting application detects carrier (receives a signal), it unsquelches and issues a COR signal to the PTG-10. When the PTG-10 receives a COR signal the tone is removed from the audio link and the receiver audio is passed through the link to the voter.

The pilot tone from the PTG-10 functions as a line proving tone to insure the integrity of the audio link in the following way: the removal of the pilot tone on the link notifies the voter to begin looking for voice signals from the voting receiver. If the voter doesn't sense voice coming from the receiver within a programmed time, it faults that particular voting site on the assumption that either the voting receiver is not functioning, or the link is broken between receiver and the voter. A voter such as the SNV-12 disallows use of that voting input until voice is received from the distant receiver or until the pilot tone returns.

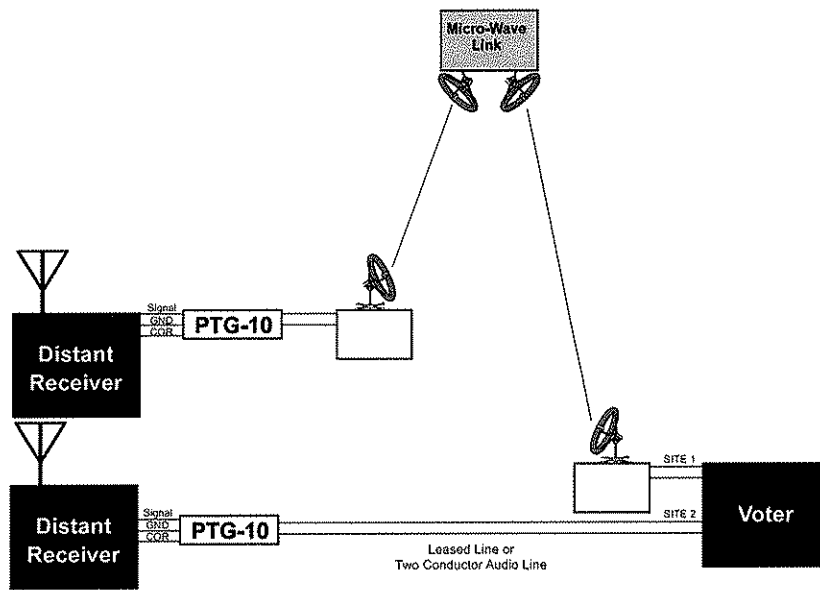

Electrical

DC Input Power:	+12 VDC ranging from +11 to +15 VDC @ 40 mA
Input Impedence:	50k Ohms unbalanced
Output Impedence:	600 Ohms balanced
Frequency Response:	Conservatively rated: 50 to 20 kHz \pm 2dB
Tone Frequencies:	1950Hz or 2175Hz, switch selectable
Tone Stability:	\pm 2Hz
Receiver Audio Input Range:	-30 to + 4 dBm, variable
Pilot Tone Output level:	-20 to + 9 dBm, variable

General

LED Indicators:	Power and COR
Size:	6.84" x 2.42" x 1.19"
Weight:	0.5lbs

Environmental

Temperature:	Operating: -20 to +55 degrees C. Storage: -40 to +85 degrees C
Humidity:	Up to 95% @ +55 degrees C.
Shock:	MIL-STD-810D, method 516.3 procedure VI
Vibration:	MIL-STD-810D, method 514.3 procedure I

Raytheon Company
Civil Communications Solutions
 5800 Departure Drive
 Raleigh, NC 27616
 legacy.sales@raytheon.com

www.raytheon.com

Raytheon

Customer Success Is Our Mission

RFQ No. _____

STATE OF WEST VIRGINIA
Purchasing Division

PURCHASING AFFIDAVIT

West Virginia Code §5A-3-10a states: No contract or renewal of any contract may be awarded by the state or any of its political subdivisions to any vendor or prospective vendor when the vendor or prospective vendor or a related party to the vendor or prospective vendor is a debtor and the debt owed is an amount greater than one thousand dollars in the aggregate.

DEFINITIONS:

"Debt" means any assessment, premium, penalty, fine, tax or other amount of money owed to the state or any of its political subdivisions because of a judgment, fine, permit violation, license assessment, defaulted workers' compensation premium, penalty or other assessment presently delinquent or due and required to be paid to the state or any of its political subdivisions, including any interest or additional penalties accrued thereon.

"Debtor" means any individual, corporation, partnership, association, limited liability company or any other form or business association owing a debt to the state or any of its political subdivisions. "Political subdivision" means any county commission; municipality; county board of education; any instrumentality established by a county or municipality; any separate corporation or instrumentality established by one or more counties or municipalities, as permitted by law; or any public body charged by law with the performance of a government function or whose jurisdiction is coextensive with one or more counties or municipalities. "Related party" means a party, whether an individual, corporation, partnership, association, limited liability company or any other form or business association or other entity whatsoever, related to any vendor by blood, marriage, ownership or contract through which the party has a relationship of ownership or other interest with the vendor so that the party will actually or by effect receive or control a portion of the benefit, profit or other consideration from performance of a vendor contract with the party receiving an amount that meets or exceeds five percent of the total contract amount.

EXCEPTION: The prohibition of this section does not apply where a vendor has contested any tax administered pursuant to chapter eleven of this code, workers' compensation premium, permit fee or environmental fee or assessment and the matter has not become final or where the vendor has entered into a payment plan or agreement and the vendor is not in default of any of the provisions of such plan or agreement.

Under penalty of law for false swearing (*West Virginia Code §61-5-3*), it is hereby certified that the vendor affirms and acknowledges the information in this affidavit and is in compliance with the requirements as stated.

WITNESS THE FOLLOWING SIGNATURE

Vendor's Name: Kenwood USA Corporation

Authorized Signature: John North Date: _____

State of Georgia

County of Forsyth, to-wit:

Taken, subscribed, and sworn to before me this 15 day of June, 2010.

My Commission expires January 6 2014

AFFIX SEAL HERE

NOTARY PUBLIC

Denise Ann Butler

DENISE ANN BUTLER
NOTARY PUBLIC
FORSYTH COUNTY, GEORGIA
MY COMMISSION EXPIRES JANUARY 6, 2014

1. 2. 3. 4. 5. 6. 7. 8. 9. 10. 11. 12. 13. 14. 15. 16. 17. 18. 19. 20. 21. 22. 23. 24. 25. 26. 27. 28. 29. 30. 31. 32. 33. 34. 35. 36. 37. 38. 39. 40. 41. 42. 43. 44. 45. 46. 47. 48. 49. 50. 51. 52. 53. 54. 55. 56. 57. 58. 59. 60. 61. 62. 63. 64. 65. 66. 67. 68. 69. 70. 71. 72. 73. 74. 75. 76. 77. 78. 79. 80. 81. 82. 83. 84. 85. 86. 87. 88. 89. 90. 91. 92. 93. 94. 95. 96. 97. 98. 99. 100.

