



State of West Virginia
 Department of Administration
 Purchasing Division
 2019 Washington Street East
 Post Office Box 50130
 Charleston, WV 25305-0130

Request for Quotation

RFQ NUMBER
DPS1014

PAGE
1

ADDRESS CORRESPONDENCE TO ATTENTION OF:
JOHN ABBOTT 304-558-2544

VENDOR

*810125207 276-647-4161
 TOWN POLICE SUPPLY
 PO BOX 417
 3985 VIRGINIA AVE
 COLLINSVILLE VA 24078

SHIP TO

WEST VIRGINIA STATE POLICE
 4124 KANAWHA TURNPIKE
 SOUTH CHARLESTON, WV
 25309 304-746-2141

DATE PRINTED	TERMS OF SALE	SHIP VIA	F.O.B.	FREIGHT TERMS
12/08/2009	Net 30	Best Way	Destination	Prepaid
BID OPENING DATE: 12/22/2009		BID OPENING TIME 01:30PM		

LINE	QUANTITY	UOP	CAT NO.	ITEM NUMBER	UNIT PRICE	AMOUNT
0001	1	LS		680-96	\$89.89	\$67,417.50
				EXPANDABLE BATONS		
				OPEN-END CONTRACT TO PROVIDE EXPANDABLE BATONS FOR THE WEST VIRGINIA STATE POLICE, PER THE ATTACHED SPECIFICATIONS.		
				EXHIBIT 3		
				LIFE OF CONTRACT: THIS CONTRACT BECOMES EFFECTIVE ON AND EXTENDS FOR A PERIOD OF ONE (1) YEAR OR UNTIL SUCH "REASONABLE TIME" THEREAFTER AS IS NECESSARY TO OBTAIN A NEW CONTRACT OR RENEW THE ORIGINAL CONTRACT. THE "REASONABLE TIME" PERIOD SHALL NOT EXCEED TWELVE (12) MONTHS. DURING THIS "REASONABLE TIME" THE VENDOR MAY TERMINATE THIS CONTRACT FOR ANY REASON UPON GIVING THE DIRECTOR OF PURCHASING 30 DAYS WRITTEN NOTICE.		
				UNLESS SPECIFIC PROVISIONS ARE STIPULATED ELSEWHERE IN THIS CONTRACT DOCUMENT, THE TERMS, CONDITIONS AND PRICING SET HEREIN ARE FIRM FOR THE LIFE OF THE CONTRACT.		
				RENEWAL: THIS CONTRACT MAY BE RENEWED UPON THE MUTUAL WRITTEN CONSENT OF THE SPENDING UNIT AND VENDOR, SUBMITTED TO THE DIRECTOR OF PURCHASING THIRTY (30) DAYS PRIOR TO THE EXPIRATION DATE. SUCH RENEWAL SHALL BE IN ACCORDANCE WITH THE TERMS AND CONDITIONS OF THE ORIGINAL CONTRACT AND SHALL BE LIMITED TO TWO (2) ONE (1) YEAR PERIODS.		

RECEIVED
 2009 DEC 21 P 12:02
 RECEIVED UNION
 STATE OF WV

SEE REVERSE SIDE FOR TERMS AND CONDITIONS		
SIGNATURE <i>Tony Lawson</i>	TELEPHONE (800) 752-5580	DATE 12/18/09
TITLE Sales Manager	FEIN 54-1273247	ADDRESS CHANGES TO BE NOTED ABOVE

WHEN RESPONDING TO RFQ, INSERT NAME AND ADDRESS IN SPACE ABOVE LABELED 'VENDOR'



State of West Virginia
 Department of Administration
 Purchasing Division
 2019 Washington Street East
 Post Office Box 50130
 Charleston, WV 25305-0130

Request for Quotation

RFQ NUMBER
DPS1014

PAGE
2

ADDRESS CORRESPONDENCE TO ATTENTION OF:
JOHN ABBOTT 304-558-2544

RECEIVED

*810125207 276-647-4161
 TOWN POLICE SUPPLY
 PO BOX 417
 3985 VIRGINIA AVE
 COLLINSVILLE VA 24078

SHIP TO

WEST VIRGINIA STATE POLICE
 4124 KANAWHA TURNPIKE
 SOUTH CHARLESTON, WV
 25309 304-746-2141

DATE PRINTED	TERMS OF SALE	SHIP VIA	F.O.B.	FREIGHT TERMS
12/08/2009	Net 30	Best Way	Destination	Prepaid
BID OPENING DATE: 12/22/2009		BID OPENING TIME 01:30PM		

LINE	QUANTITY	UOP	CAT NO	ITEM NUMBER	UNIT PRICE	AMOUNT
<p>CANCELLATION: THE DIRECTOR OF PURCHASING RESERVES THE RIGHT TO CANCEL THIS CONTRACT IMMEDIATELY UPON WRITTEN NOTICE TO THE VENDOR IF THE COMMODITIES AND/OR SERVICES SUPPLIED ARE OF AN INFERIOR QUALITY OR DO NOT CONFORM TO THE SPECIFICATIONS OF THE BID AND CONTRACT HEREIN.</p> <p>OPEN MARKET CLAUSE: THE DIRECTOR OF PURCHASING MAY AUTHORIZE A SPENDING UNIT TO PURCHASE ON THE OPEN MARKET, WITHOUT THE FILING OF A REQUISITION OR COST ESTIMATE, ITEMS SPECIFIED ON THIS CONTRACT FOR IMMEDIATE DELIVERY IN EMERGENCIES DUE TO UNFORESEEN CAUSES (INCLUDING BUT NOT LIMITED TO DELAYS IN TRANSPORTATION OR AN UNANTICIPATED INCREASE IN THE VOLUME OF WORK.)</p> <p>QUANTITIES: QUANTITIES LISTED IN THE REQUISITION ARE APPROXIMATIONS ONLY, BASED ON ESTIMATES SUPPLIED BY THE STATE SPENDING UNIT. IT IS UNDERSTOOD AND AGREED THAT THE CONTRACT SHALL COVER THE QUANTITIES ACTUALLY ORDERED FOR DELIVERY DURING THE TERM OF THE CONTRACT, WHETHER MORE OR LESS THAN THE QUANTITIES SHOWN.</p> <p>ORDERING PROCEDURE: SPENDING UNIT(S) SHALL ISSUE A WRITTEN STATE CONTRACT ORDER (FORM NUMBER WV-39) TO THE VENDOR FOR COMMODITIES COVERED BY THIS CONTRACT. THE ORIGINAL COPY OF THE WV-39 SHALL BE MAILED TO THE VENDOR AS AUTHORIZATION FOR SHIPMENT, A SECOND COPY MAILED TO THE PURCHASING DIVISION, AND A THIRD COPY RETAINED BY THE SPENDING UNIT.</p> <p>BANKRUPTCY: IN THE EVENT THE VENDOR/CONTRACTOR FILES FOR BANKRUPTCY PROTECTION, THE STATE MAY DEEM THE CONTRACT NULL AND VOID, AND TERMINATE SUCH CONTRACT WITHOUT FURTHER ORDER.</p> <p>THE TERMS AND CONDITIONS CONTAINED IN THIS CONTRACT</p>						

SEE REVERSE SIDE FOR TERMS AND CONDITIONS

SIGNATURE	TELEPHONE	DATE
<i>Tommy Lawson</i>	(800) 752-5580	12/18/09
TITLE	FEIN	ADDRESS CHANGES TO BE NOTED ABOVE
Sales Manager	54-1273247	

WHEN RESPONDING TO RFQ, INSERT NAME AND ADDRESS IN SPACE ABOVE LABELED 'VENDOR'



State of West Virginia
 Department of Administration
 Purchasing Division
 2019 Washington Street East
 Post Office Box 50130
 Charleston, WV 25305-0130

Request for Quotation

RFQ NUMBER
DPS1014

PAGE
3

ADDRESS CORRESPONDENCE TO ATTENTION OF
JOHN ABBOTT
304-558-2544

PURCHASER

*810125207 276-647-4161
 TOWN POLICE SUPPLY
 PO BOX 417
 3985 VIRGINIA AVE
 COLLINSVILLE VA 24078

SHIP TO

WEST VIRGINIA STATE POLICE
 4124 KANAWHA TURNPIKE
 SOUTH CHARLESTON, WV
 25309 304-746-2141

DATE PRINTED	TERMS OF SALE	SHIP VIA	F.O.B.	FREIGHT TERMS
12/08/2009	Net 30	Best Way	Destination	Prepaid

BID OPENING DATE: **12/22/2009** BID OPENING TIME **01:30PM**

LINE	QUANTITY	UOP	CAT NO	ITEM NUMBER	UNIT PRICE	AMOUNT
<p>SHALL SUPERSEDE ANY AND ALL SUBSEQUENT TERMS AND CONDITIONS WHICH MAY APPEAR ON ANY ATTACHED PRINTED DOCUMENTS SUCH AS PRICE LISTS, ORDER FORMS, SALES AGREEMENTS OR MAINTENANCE AGREEMENTS, INCLUDING ANY ELECTRONIC MEDIUM SUCH AS CD-ROM.</p> <p>REV. 05/26/2009</p> <p>EXHIBIT 4</p> <p>LOCAL GOVERNMENT BODIES: UNLESS THE VENDOR INDICATES IN THE BID HIS REFUSAL TO EXTEND THE PRICES, TERMS, AND CONDITIONS OF THE BID TO COUNTY, SCHOOL, MUNICIPAL AND OTHER LOCAL GOVERNMENT BODIES, THE BID SHALL EXTEND TO POLITICAL SUBDIVISIONS OF THE STATE OF WEST VIRGINIA. IF THE VENDOR DOES NOT WISH TO EXTEND THE PRICES, TERMS, AND CONDITIONS OF THE BID TO ALL POLITICAL SUBDIVISIONS OF THE STATE, THE VENDOR MUST CLEARLY INDICATE SUCH REFUSAL IN HIS BID. SUCH REFUSAL SHALL NOT PREJUDICE THE AWARD OF THIS CONTRACT IN ANY MANNER.</p> <p>REV. 3/88</p> <p style="text-align: center;">NOTICE</p> <p>A SIGNED BID MUST BE SUBMITTED TO:</p> <p style="text-align: center;">DEPARTMENT OF ADMINISTRATION PURCHASING DIVISION BUILDING 15 2019 WASHINGTON STREET, EAST CHARLESTON, WV 25305-0130</p>						

SEE REVERSE SIDE FOR TERMS AND CONDITIONS

SIGNATURE	TELEPHONE	DATE
<i>Tony Lawson</i>	(800) 752-5580	12/18/09
TITLE	FEIN	ADDRESS CHANGES TO BE NOTED ABOVE
Sales Manager	54-1273247	

WHEN RESPONDING TO RFQ, INSERT NAME AND ADDRESS IN SPACE ABOVE LABELED 'VENDOR'



State of West Virginia
 Department of Administration
 Purchasing Division
 2019 Washington Street East
 Post Office Box 50130
 Charleston, WV 25305-0130

Request for Quotation

RFQ NUMBER
DPS1014

PAGE
4

ADDRESS CORRESPONDENCE TO ATTENTION OF
JOHN ABBOTT
304-558-2544

***810125207 276-647-4161**
TOWN POLICE SUPPLY
PO BOX 417
3985 VIRGINIA AVE
COLLINSVILLE VA 24078

WEST VIRGINIA STATE POLICE
4124 KANAWHA TURNPIKE
SOUTH CHARLESTON, WV
25309 304-746-2141

DATE PRINTED 12/08/2009	TERMS OF SALE Net 30	SHIP VIA Best Way	F.O.B. Destination	FREIGHT TERMS Prepaid
-----------------------------------	-------------------------	----------------------	-----------------------	--------------------------

BID OPENING DATE: **12/22/2009** BID OPENING TIME **01:30PM**

LINE	QUANTITY	UOP	CAT. NO.	ITEM NUMBER	UNIT PRICE	AMOUNT
<p>THE BID SHOULD CONTAIN THIS INFORMATION ON THE FACE OF THE ENVELOPE OR THE BID MAY NOT BE CONSIDERED:</p> <p>SEALED BID</p> <p>BUYER: JOHN ABBOTT (32)</p> <p>RFQ. NO.: DPS1014</p> <p>BID OPENING DATE: 12/22/2009</p> <p>BID OPENING TIME: 1:30 PM</p> <p>PLEASE PROVIDE A FAX NUMBER IN CASE IT IS NECESSARY TO CONTACT YOU REGARDING YOUR BID: (276) 647-4812</p> <p>CONTACT PERSON (PLEASE PRINT CLEARLY): Tony Lawson</p> <p>***** THIS IS THE END OF RFQ DPS1014 ***** TOTAL: \$67,417.50</p>						

SEE REVERSE SIDE FOR TERMS AND CONDITIONS			
SIGNATURE <i>Tony Lawson</i>	TELEPHONE (800) 752-5580	DATE 12/18/09	
TITLE Sales Manager	FEIN 54-1273247	ADDRESS CHANGES TO BE NOTED ABOVE	

WHEN RESPONDING TO RFQ, INSERT NAME AND ADDRESS IN SPACE ABOVE LABELED 'VENDOR'

The West Virginia State Police is soliciting competitive bids for the purchase of ASP expandable baton or equal. Vendors submitting bids do not need to be a registered vendor with the State of West Virginia to submit a bid, however the lowest bidder that meets the minimum specifications will have to register with the West Virginia State Purchasing Division and pay the \$125.00 Vendor Registration fee prior to being awarded this contract. This contract will be available for all State, County, and Municipal agencies to purchase from.

GENERAL SPECIFICATIONS:

The baton shall equal, meet or exceed the following specifications:

	YES	NO
1. The Expandable baton shall be twenty six (26) inches (expanded)	<input checked="" type="checkbox"/>	<input type="checkbox"/>
2. The Expandable baton shall be 9.5" in length collapsed	<input checked="" type="checkbox"/>	<input type="checkbox"/>
3. Expandable batons shall be of an impact closing design	<input checked="" type="checkbox"/>	<input type="checkbox"/>
4. The baton closing system shall utilize gross motor skills	<input checked="" type="checkbox"/>	<input type="checkbox"/>
5. The baton shall have less than twenty (20) parts	<input checked="" type="checkbox"/>	<input type="checkbox"/>
6. Each baton shaft shall be produced from 4140 steel or equal	<input checked="" type="checkbox"/>	<input type="checkbox"/>
7. Batons shall have a Rockwell C-scale striking surface hardness of 49 to 57	<input checked="" type="checkbox"/>	<input type="checkbox"/>
8. Batons shall have a tensile strength of at least 238,000 PSI	<input checked="" type="checkbox"/>	<input type="checkbox"/>
9. The baton handle shall be undercoated with yellow zinc dichromate or equal	<input checked="" type="checkbox"/>	<input type="checkbox"/>
10. The baton handle shall be coated with a textured black industrial grade powder coating	<input checked="" type="checkbox"/>	<input type="checkbox"/>
11. The baton handle shall have a replacement foam grip at least 1/16" thick with a protective front collar and end cap	<input checked="" type="checkbox"/>	<input type="checkbox"/>
12. Batons shall have no knurling or sharp edges	<input checked="" type="checkbox"/>	<input type="checkbox"/>
13. The baton end cap shall be sealed with an o-ring	<input checked="" type="checkbox"/>	<input type="checkbox"/>

- | | | |
|---|---|-------|
| 14. Retention clips shall be tapered of a no snag design | ✓ | _____ |
| 15. Retention clips shall be easily replaceable as a unit | ✓ | _____ |
| 16. The successful bidder shall be a factory authorized service center and provide documentation from manufacturer certifying them | ✓ | _____ |
| 17. The manufacturer shall provide the name and resume of their litigation consultant including documentation of a minimum of fifty (50) cases of expert witness testimony concerning the use of force done on behalf of law enforcement agencies | ✓ | _____ |
| 18. A retention clip adjustment tool kit shall be available for the batons purchased | ✓ | _____ |
| 19. A repair and replacement parts kit shall be provided without charge as part of the bid | ✓ | _____ |
| 20. A grip repair kit shall be provided as part of the bid at no charge | ✓ | _____ |
| 21. A parts manual including an exploded view of the baton with part numbers shall be provided without charge as part of the bid | ✓ | _____ |
| 22. A cutaway model of the baton for training purposes shall be provided without charge as part of the bid | ✓ | _____ |
| 23. The baton shall be fully serviceable by a department armorer | ✓ | _____ |
| 24. Training of agency instructors shall be provided for no more than five (5) instructors and the training will occur at the West Virginia State Police Academy | ✓ | _____ |
| 25. The manufacturer shall provide a lifetime warranty on all products, a copy of which shall be provided with the bid | ✓ | _____ |
| 26. The baton will have concealed window-breaking device component | ✓ | _____ |
| 27. The end cap will have an engraving to be determined by the West Virginia State Police | ✓ | _____ |

- | | | |
|---|-------------------------------------|-------|
| 28. A serial number will be laser engraved on the mid-shaft of the baton | <input checked="" type="checkbox"/> | _____ |
| 29. The manufacturer shall be ISO 9001:2000 Certified and provide a copy of current certification at the time of the bid. | <input checked="" type="checkbox"/> | _____ |
| 30. The bid price will include the baton scabbard | <input checked="" type="checkbox"/> | _____ |
| A. The baton scabbard shall be made of injection molded black Delrin with a clarino finish | <input checked="" type="checkbox"/> | _____ |
| B. The scabbard shall retain either a retracted or expanded baton | <input checked="" type="checkbox"/> | _____ |
| C. A retracted baton shall not shake open in the scabbard | <input checked="" type="checkbox"/> | _____ |
| D. The belt slide shall be one piece | <input checked="" type="checkbox"/> | _____ |
| E. The scabbard belt width shall be screw lock adjustable | <input checked="" type="checkbox"/> | _____ |
| F. The scabbard shall rotate 360 degrees with at least twelve (12) retention positions | <input checked="" type="checkbox"/> | _____ |
| G. A free floating, adjustable steel retention clip shall provide constant holding pressure on a holstered baton | <input checked="" type="checkbox"/> | _____ |
| H. An expanded baton shall break out the side of the scabbard | <input checked="" type="checkbox"/> | _____ |
| I. A spare fastener shall be stored in the case for each type of scabbard screw | <input checked="" type="checkbox"/> | _____ |
| J. A disassembly and maintenance tool shall be included as part of the case | <input checked="" type="checkbox"/> | _____ |

Vendors not meeting the above specifications will be disqualified from the bid process.

ADDITIONAL INFORMATION

Vendors will provide a sample of the product for evaluation purposes upon request by the West Virginia State Police, prior to the award of this contract.

WARRANTY

Vendor will provide a lifetime warranty against manufacturer defects.

SHIPPING

Shipping will be included in the bid price. The product will be shipped to the West Virginia State Police, Procurement Division, 4124 Kanawha Turnpike, South Charleston, WV 25309.

BID QUOTATIONS

The West Virginia State Police has the intention of making an initial purchase of approximately 750 units (Batons/Scabbards). The West Virginia State Police has the potential to purchase approximately 50 units per year over the life of the contract.

750 units

Cost per unit \$ 89.89 Total Cost \$ 67,417.50

(Baton: \$63.34 / Scabbard: \$26.55)
F26FB # 52634

SUGGESTED VENDORS:

1. Galls * 709070358-02
 Jeffrey Bush
 2680 Palumbo Drive
 Lexington, KY 40509-1000

 Phone: 1-800-876-4242 ext. 2278 Fax: 1-877-914-2557

2. Adamson Industries Corporation * 514153221
 45 Research Drive
 Haverhill, MA 01832

 Phone: 1-800-232-0162 Fax: 1-800-710-9099

3. Ray O'Herron Company Incorporated * 306155824
 3549 North Vermilion
 PO Box 1070
 Danville, IL 61834-1070

 Phone: 1-800-223-2097 Fax: 1-888-223-3235

4. Town Police Supply * 810125207
 3985 Virginia Avenue
 Collinsville, VA 24078

 Toll-Free: (800) 752-5580 Fax: (276) 647-4812
 Phone: (276) 647-4161

5. Chief Supply * 702154751
 8604 Cliff Cameron Drive
 Suite 105
 Charlotte, NC 28269

 Phone: 1-888-588-8569 Fax: 1-888-588-8590

6. Southern Police Equipment * 319095428
 7609 Midlothian Turnpike
 Richmond, VA 23235

 Phone: 1-800-542-5243 Fax: 1-804-323-5067

7. ON NEXT PAGE * C 28123505

7. Blackheart International, L.L.C.
PO Box 9
RR3 Box 115
Philippi, WV 26416

Phone: 1-877-244-8166

Fax: 1-304-457-1281

STATE OF WEST VIRGINIA
Purchasing Division**PURCHASING AFFIDAVIT****VENDOR OWING A DEBT TO THE STATE:**

West Virginia Code §5A-3-10a provides that: No contract or renewal of any contract may be awarded by the state or any of its political subdivisions to any vendor or prospective vendor when the vendor or prospective vendor or a related party to the vendor or prospective vendor is a debtor and the debt owed is an amount greater than one thousand dollars in the aggregate

PUBLIC IMPROVEMENT CONTRACTS & DRUG-FREE WORKPLACE ACT:

If this is a solicitation for a public improvement construction contract, the vendor, by its signature below, affirms that it has a written plan for a drug-free workplace policy in compliance with Article 1D, Chapter 21 of the *West Virginia Code*. The vendor **must** make said affirmation with its bid submission. Further, public improvement construction contract may not be awarded to a vendor who does not have a written plan for a drug-free workplace policy in compliance with Article 1D, Chapter 21 of the *West Virginia Code* and who has not submitted that plan to the appropriate contracting authority in timely fashion. For a vendor who is a subcontractor, compliance with Section 5, Article 1D, Chapter 21 of the *West Virginia Code* may take place before their work on the public improvement is begun.

ANTITRUST:

In submitting a bid to any agency for the state of West Virginia, the bidder offers and agrees that if the bid is accepted the bidder will convey, sell, assign or transfer to the state of West Virginia all rights, title and interest in and to all causes of action it may now or hereafter acquire under the antitrust laws of the United States and the state of West Virginia for price fixing and/or unreasonable restraints of trade relating to the particular commodities or services purchased or acquired by the state of West Virginia. Such assignment shall be made and become effective at the time the purchasing agency tenders the initial payment to the bidder.

I certify that this bid is made without prior understanding, agreement, or connection with any corporation, firm, limited liability company, partnership or person or entity submitting a bid for the same materials, supplies, equipment or services and is in all respects fair and without collusion or fraud. I further certify that I am authorized to sign the certification on behalf of the bidder or this bid.

LICENSING:

Vendors must be licensed and in good standing in accordance with any and all state and local laws and requirements by any state or local agency of West Virginia, including, but not limited to, the West Virginia Secretary of State's Office, the West Virginia Tax Department, West Virginia Insurance Commission, or any other state agencies or political subdivision. Furthermore, the vendor must provide all necessary releases to obtain information to enable the Director or spending unit to verify that the vendor is licensed and in good standing with the above entities.

CONFIDENTIALITY:

The vendor agrees that he or she will not disclose to anyone, directly or indirectly, any such personally identifiable information or other confidential information gained from the agency, unless the individual who is the subject of the information consents to the disclosure in writing or the disclosure is made pursuant to the agency's policies, procedures and rules. Vendor further agrees to comply with the Confidentiality Policies and Information Security Accountability Requirements, set forth in <http://www.state.wv.us/admin/purchase/privacy/noticeConfidentiality.pdf>.

Under penalty of law for false swearing (*West Virginia Code* §61-5-3), it is hereby certified that the vendor affirms and acknowledges the information in this affidavit and is in compliance with the requirements as stated.

Vendor's Name: Town Police Supply
 Authorized Signature: Tommy Lawson Date: 12/18/09

State of West Virginia VENDOR PREFERENCE CERTIFICATE

Certification and application* is hereby made for Preference in accordance with *West Virginia Code*, §5A-3-37 (Does not apply to construction contracts). *West Virginia Code*, §5A-3-37, provides an opportunity for qualifying vendors to request (at the time of bid) preference for their residency status. Such preference is an evaluation method only and will be applied only to the cost bid in accordance with the *West Virginia Code*. This certificate for application is to be used to request such preference. The Purchasing Division will make the determination of the Resident Vendor Preference, if applicable.

1. **Application is made for 2.5% resident vendor preference for the reason checked:**
 Bidder is an individual resident vendor and has resided continuously in West Virginia for four (4) years immediately preceding the date of this certification; or,
 Bidder is a partnership, association or corporation resident vendor and has maintained its headquarters or principal place of business continuously in West Virginia for four (4) years immediately preceding the date of this certification; or 80% of the ownership interest of Bidder is held by another individual, partnership, association or corporation resident vendor who has maintained its headquarters or principal place of business continuously in West Virginia for four (4) years immediately preceding the date of this certification; or,
 Bidder is a nonresident vendor which has an affiliate or subsidiary which employs a minimum of one hundred state residents and which has maintained its headquarters or principal place of business within West Virginia continuously for the four (4) years immediately preceding the date of this certification; or,
2. **Application is made for 2.5% resident vendor preference for the reason checked:**
 Bidder is a resident vendor who certifies that, during the life of the contract, on average at least 75% of the employees working on the project being bid are residents of West Virginia who have resided in the state continuously for the two years immediately preceding submission of this bid; or,
3. **Application is made for 2.5% resident vendor preference for the reason checked:**
 Bidder is a nonresident vendor employing a minimum of one hundred state residents or is a nonresident vendor with an affiliate or subsidiary which maintains its headquarters or principal place of business within West Virginia employing a minimum of one hundred state residents who certifies that, during the life of the contract, on average at least 75% of the employees or Bidder's affiliate's or subsidiary's employees are residents of West Virginia who have resided in the state continuously for the two years immediately preceding submission of this bid; or,
4. **Application is made for 5% resident vendor preference for the reason checked:**
 Bidder meets either the requirement of both subdivisions (1) and (2) or subdivision (1) and (3) as stated above; or,
5. **Application is made for 3.5% resident vendor preference who is a veteran for the reason checked:**
 Bidder is an individual resident vendor who is a veteran of the United States armed forces, the reserves or the National Guard and has resided in West Virginia continuously for the four years immediately preceding the date on which the bid is submitted; or,
6. **Application is made for 3.5% resident vendor preference who is a veteran for the reason checked:**
 Bidder is a resident vendor who is a veteran of the United States armed forces, the reserves or the National Guard, if, for purposes of producing or distributing the commodities or completing the project which is the subject of the vendor's bid and continuously over the entire term of the project, on average at least seventy-five percent of the vendor's employees are residents of West Virginia who have resided in the state continuously for the two immediately preceding years.

Bidder understands if the Secretary of Revenue determines that a Bidder receiving preference has failed to continue to meet the requirements for such preference, the Secretary may order the Director of Purchasing to: (a) reject the bid; or (b) assess a penalty against such Bidder in an amount not to exceed 5% of the bid amount and that such penalty will be paid to the contracting agency or deducted from any unpaid balance on the contract or purchase order.

By submission of this certificate, Bidder agrees to disclose any reasonably requested information to the Purchasing Division and authorizes the Department of Revenue to disclose to the Director of Purchasing appropriate information verifying that Bidder has paid the required business taxes, provided that such information does not contain the amounts of taxes paid nor any other information deemed by the Tax Commissioner to be confidential.

Under penalty of law for false swearing (West Virginia Code, §61-5-3), Bidder hereby certifies that this certificate is true and accurate in all respects; and that if a contract is issued to Bidder and if anything contained within this certificate changes during the term of the contract, Bidder will notify the Purchasing Division in writing immediately.

Bidder: _____ Signed: _____

Date: _____ Title: _____

*Check any combination of preference consideration(s) indicated above, which you are entitled to receive



CERTIFICATE OF APPROVAL

This is to certify that the Quality Management System of:

**ASP Inc.
Appleton, Wisconsin, USA**

has been approved by Lloyd's Register Quality Assurance
to the following Quality Management System Standards:

ISO 9001:2000

The Quality Management System is applicable to:

**Packaging, Distribution and Management of
Design and Manufactured Law Enforcement Equipment.**

Approval
Certificate No: UQA 4000552

Original Approval: October 1, 2007

Current Certificate: October 1, 2007

Certificate Expiry: October 1, 2010

Mona Wobleski

Issued by: LRQA, Inc. Houston



001



This document is subject to the provision on the reverse
1401 Enclave Parkway, Suite 200, Houston, Texas 77077, USA

This approval is carried out in accordance with the LRQA assessment and certification procedures and monitored by LRQA.
The use of the UKAS Accreditation Mark indicates Accreditation in respect of those activities covered by the Accreditation Certificate Number 001
Metric Revision 13



16 December 2009

Mark Tosh
Town Police Supply
3985 Virginia AVE
Collinsville, VA 24078

RE: RFQ #DPS1014

MR Tosh:

ASP will conduct an ASP Instructor Course - Baton (AIC) providing Factory Instructor Certification in 2010 to support the requirement as described in the West Virginia State Police Request for Quotation #DPS1014 for Town Police Supply

This letter should serve as verification of this training requirement for this RFQ and can be duplicated for third party use.

The West Virginia State Police is welcome to contact ASP for assistance if they have any questions and/or comments.

Sincerely,

ASP, INC

Ken Cope
Director of Sales & Marketing

nn



16 December 2009

Mark Tosh
Town Police Supply
3985 Virginia AVE
Collinsville, VA 24078

RE: RFQ #DPS1014

MR Tosh:

On behalf of ASP, I am pleased to confirm that your company Town Police Supply is an ASP Factory Authorized Service Center.

Town Police Supply is authorized to make warranty and service repairs to ASP products in support of the West Virginia State Police Request for Quotation #DPS1014.

This letter should serve as verification of status for this Bid/Tender and can be duplicated for third party use.

The West Virginia State Police is welcome to contact ASP for assistance or if they have any questions and/or comments.

Sincerely,

ASP, INC

Ken Cope
Director of Sales & Marketing

nn



Warranty - Friction Loc Baton

LIFETIME LIMITED WARRANTY

ASP, INC warrants each Friction Loc Baton to be free from defects in materials and workmanship. Our obligation under this warranty shall be limited to replacing or repairing any Friction Loc Baton or part thereof returned (prepaid) to us and found to be defective in either material or workmanship. This service will be provided free of charge for parts or labor.

Misuse voids any warranty, expressed or implied. Any Friction Loc Baton damaged by misuse will be repaired at a minimal charge if returned (prepaid) to ASP, INC · 2511 E Capitol DR · Appleton, WI 54911.

ASP reserves the right to make changes at any time in prices, specifications or design without notice. ASP may add or remove accessory materials and add or discontinue models without incurring obligation.

This Limited Warranty gives you specific legal rights, and you may also have other rights which vary from state to state. This Limited Warranty and Statement of Liabilities supersedes all previous warranties and commitments.

DISCLAIMER OF ALL IMPLIED WARRANTIES AND STATEMENT OF LIABILITIES

The parties agree that this instrument constitutes the entire warranty agreement between the parties, superseding all previous communications, oral or written, and no changes, amendments, or additions hereto will be recognized unless in writing signed by both ASP and the client. It is expressly agreed by both parties that no representations or warranties, expressed or implied, have been or are made by ASP except as stated herein, and ASP makes NO WARRANTY, EXPRESSED OR IMPLIED, AS TO ANY IMPLIED WARRANTY OF MERCHANTABILITY OR AS TO ANY IMPLIED WARRANTY OF FITNESS FOR ANY PARTICULAR PURPOSE, or with respect to any other obligation or liability on the part of ASP.

The Laws of the State of Wisconsin shall govern construction and interpretation of this warranty.

The exclusive remedy for claims arising hereunder shall be for damages. The liability of ASP for any and all loss or damage resulting from any cause whatsoever including the negligence of ASP and for alleged damaged or defective goods, irrespective of whether such defects are discoverable or latent, shall in no event exceed the price of the particular Friction Loc Baton with respect to which losses or damages are claimed, or, at the election of ASP, the repair or replacement of defective or damaged equipment. IN NO EVENT, INCLUDING THE CASE OF A CLAIM OF NEGLIGENCE, SHALL ASP BE LIABLE FOR INCIDENTAL OR CONSEQUENTIAL DAMAGES ARISING IN CONNECTION WITH THE USE OR INABILITY TO USE THIS PRODUCT.

WARNING: BUYER POSSESSES, CARRIES AND USES THE ASP FRICTION LOC BATON AT HIS OR HER OWN RISK

The Friction Loc Baton is classified as an IMPACT or DANGEROUS WEAPON and is sold by ASP with the specific understanding that ASP assumes no liability whatsoever for the safe use, handling or resale of any Friction Loc Baton under federal, state or local laws and regulations. It is essential, and the client hereby agrees, that he or she will follow all safety procedures prescribed by ASP including use by only persons trained and certified by ASP Certified Baton Instructors. For a list of Certified Instructors and training programs, contact the Training and Certification Section of ASP at (920) 735-6242.

The Friction Loc Baton should never be extended open in the direction of any individual. It is possible with extreme use or after an extended period of time that the swages which form the locking mechanism for the baton shaft may fatigue or crack. This is a normal process due to wear of the metal surfaces. In such circumstances, the shafts of the Friction Loc Baton may separate rapidly and unexpectedly during extension. For this reason, when extending the Friction Loc Baton, always be certain that the tip of the unit is pointed in a safe direction.

ASP assumes no responsibility or liability whatsoever, regardless of nature, for physical injury or property damage resulting from intentional, accidental or negligent misuse, or for the function of any Friction Loc Baton subjected to influences beyond the control of ASP, and we will honor no claims which may result from careless handling, unauthorized adjustments, improper use, accident or negligence.



Warranty - SideBreak Scabbard

LIFETIME LIMITED WARRANTY

ASP, INC warrants each SideBreak Scabbard to be free from defects in materials and workmanship. Our obligation under this warranty shall be limited to replacing or repairing any SideBreak Scabbard or part thereof returned (prepaid) to us and found to be defective in either material or workmanship. This service will be provided free of charge for parts or labor.

Misuse voids any warranty, expressed or implied. Any SideBreak Scabbard damaged by misuse will be repaired at a minimal charge if returned (prepaid) to ASP, INC 2511 E Capitol DR - Appleton, WI 54911.

ASP reserves the right to make changes at any time in prices, specifications or design without notice. ASP may add or remove accessory materials and add or discontinue models without incurring obligation.

This Limited Warranty gives you specific legal rights, and you may also have other rights which vary from state to state. This Limited Warranty and Statement of Liabilities supersedes all previous warranties and commitments.

DISCLAIMER OF ALL IMPLIED WARRANTIES AND STATEMENT OF LIABILITIES

The parties agree that this instrument constitutes the entire warranty agreement between the parties, superseding all previous communications, oral or written, and no changes, amendments, or additions hereto will be recognized unless in writing signed by both ASP and the client. It is expressly agreed by both parties that no representations or warranties, expressed or implied, have been or are made by ASP except as stated herein, and ASP makes NO WARRANTY, EXPRESSED OR IMPLIED, AS TO ANY IMPLIED WARRANTY OF MERCHANTABILITY OR AS TO ANY IMPLIED WARRANTY OF FITNESS FOR ANY PARTICULAR PURPOSE, or with respect to any other obligation or liability on the part of ASP.

The Laws of the State of Wisconsin shall govern construction and interpretation of this warranty.

The exclusive remedy for claims arising hereunder shall be for damages. The liability of ASP for any and all loss or damage resulting from any cause whatsoever including the negligence of ASP and for alleged damaged or defective goods, irrespective of whether such defects are discoverable or latent, shall in no event exceed the price of the particular SideBreak Scabbard with respect to which losses or damages are claimed, or, at the election of ASP, the repair or replacement of defective or damaged equipment. IN NO EVENT, INCLUDING THE CASE OF A CLAIM OF NEGLIGENCE, SHALL ASP BE LIABLE FOR INCIDENTAL OR CONSEQUENTIAL DAMAGES ARISING IN CONNECTION WITH THE USE OR INABILITY TO USE THIS PRODUCT.

PARTS MANUAL

ASP, INC
Box 1794
2511 E Capitol DR
Appleton, WI 54911

O (800) 236-6243 · (920) 735-6242
F (800) 236-8601 · (920) 735-6245

asp-usa.com



January 2009

INDEX

Friction Loc Baton Technical Specifications	1
F16 ASP Tactical Baton	2
F21 ASP Tactical Baton	3
F26 ASP Tactical Baton	4
LeverLoc Baton Technical Specifications	5
L16 LeverLoc Baton	6
L21 LeverLoc Baton	7
L26 LeverLoc Baton	8
16 SideBreak Slide Scabbard	9
16 SideBreak Clip Scabbard	10
16 SideBreak Paddle Scabbard	11
16 Federal Slide Scabbard	12
16 Federal Paddle Scabbard	13
21 SideBreak Slide Scabbard	14
21 SideBreak Clip Scabbard	15
21 SideBreak Paddle Scabbard	16
21 Federal Slide Scabbard	17
21 Federal Paddle Scabbard	18
26 SideBreak Slide Scabbard	19
26 SideBreak Clip Scabbard	20
26 SideBreak Paddle Scabbard	21
26 Federal Slide Scabbard	22
26 Federal Paddle Scabbard	23
Palm Defender OC	24
Key Defender OC	25
Street Defender OC	26
Tactical Defender OC	27
21 Training Baton	28
26 Training Baton	29
Triad Elite	30
Tactical Handcuffs Technical Specifications	31
Chain Handcuff	32
Hinge Handcuff	33
Rigid Handcuff	34



Box 1794 · Appleton, WI 54912 (920) 735-6242 Fax (920) 735-6245 asp-usa.com

Friction Loc Baton

TECHNICAL SPECIFICATIONS

	F16	F21	F26
Material	4140 Alloy Steel (Airweights 7075)		
Tubing Designation	Seamless		
Striking Surface	49+ Rockwell C-Scale		
Diameter	1	1	1
	<i>25.4mm</i>	<i>25.4mm</i>	<i>25.4mm</i>
Length Closed	6.20	7.70	9.50
	<i>15.75cm</i>	<i>19.56cm</i>	<i>24.13cm</i>
Length Expanded	15.63	20.0	25.60
	<i>39.69cm</i>	<i>50.80cm</i>	<i>65.02cm</i>
Steel Weight	13.3	16.3	20.0
	<i>377g</i>	<i>462g</i>	<i>577g</i>
Airweight Weight	7.3	8.9	11.2
	<i>207g</i>	<i>252g</i>	<i>318g</i>
Handle			
Surface	Foam, DuraTec, Wavemaster		
Tubing	7/8 OD x 14 Gauge (.083)		
	<i>22.4mm OD x 14 Gauge (2mm)</i>		
Dimensions	5.80	7.30	9.20
	<i>14.73cm</i>	<i>18.54cm</i>	<i>23.37cm</i>
Coating	Textured Powdered Paint		
Corrosion Resistance	Yellow Zinc Dichromate (Black Anodized)		
Middle Shaft			
Tubing	5/8 OD x 16 Gauge (.065)		
	<i>15.63mm OD x 16 Gauge (1.63mm)</i>		
Dimensions	5.60	7.10	8.90
	<i>14.22cm</i>	<i>18.03cm</i>	<i>22.61cm</i>
Coating	Chrome, Electroless or Gold Plated		
End Shaft			
Tubing	7/16 OD x 14 Gauge (.083)		
	<i>10.90mm OD x 14 Gauge (2mm)</i>		
Dimensions	5.40	6.90	8.80
	<i>13.72cm</i>	<i>17.53cm</i>	<i>22.35cm</i>
Coating	Chrome, Electroless or Gold Plated		
Cap			
Coating	Textured Powdered Paint		
Corrosion Resistance	Yellow Zinc Dichromate (Black Anodized)		
O-Ring Sealed	Internal		
Retention Clip	Assembly	Assembly	Assembly

NOTE: Metric measurements are printed in italic

F16 DATABASE

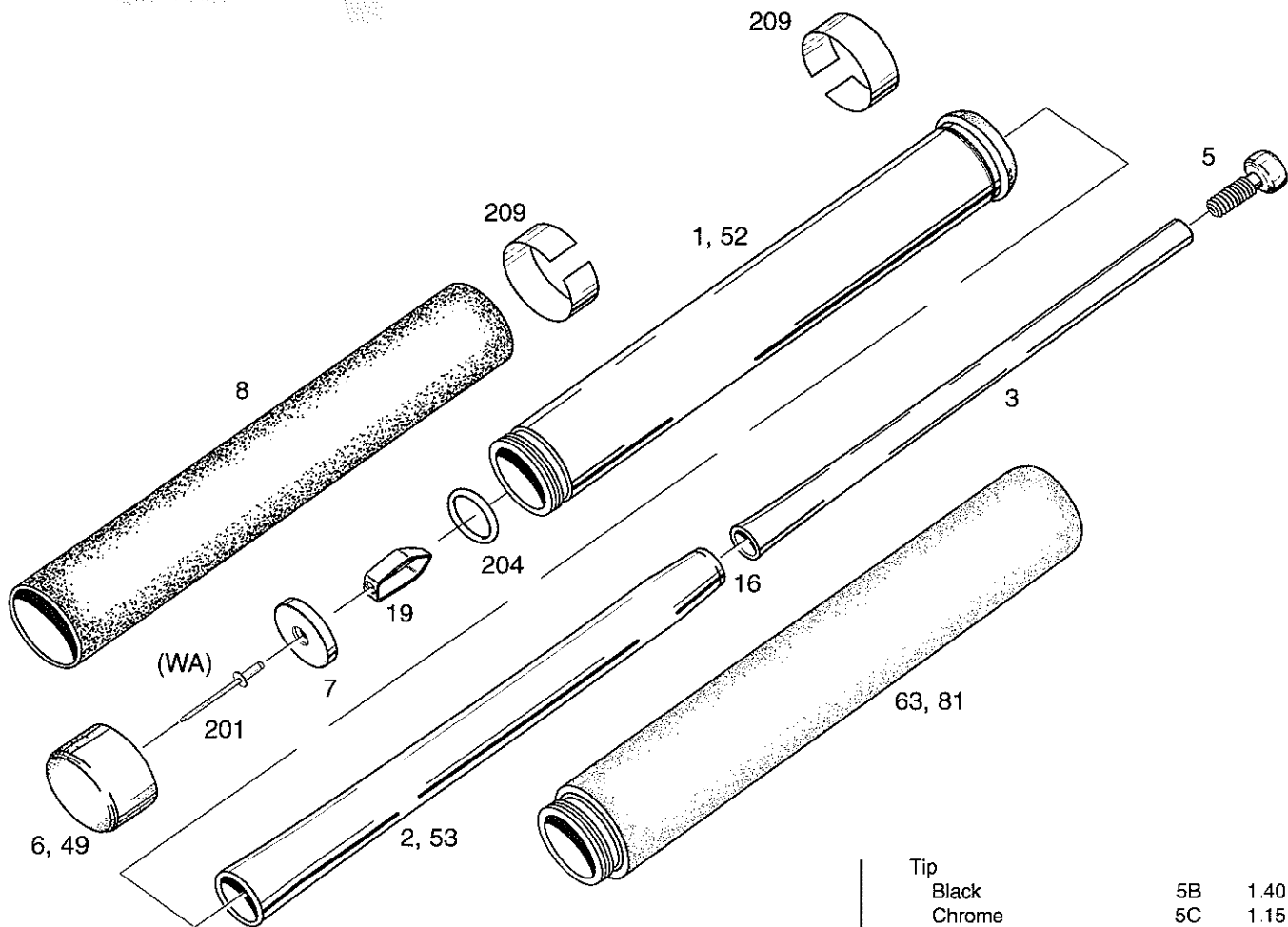
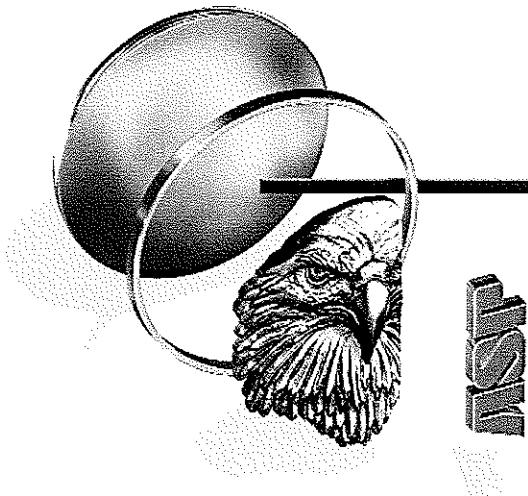

Handle		
Black	1	21.15
Electroless	1E	21.45
Airweight (Aluminum)	52	21.15
Federal	63	17.80
DuraTec (Aluminum)	81	16.75
Middle Tube		
Black	2B	9.25
Chrome	2C	8.05
Electroless	2E	9.50
Gold (Presentation)	2G	15.50
Airweight	53	17.45
End Tube		
Black	3B	10.25
Chrome	3C	9.05
Electroless	3E	10.20
Gold (Presentation)	3G	16.00

Tip		
Black	5B	1.40
Chrome	5C	1.15
Electroless	5E	.95
Gold (Presentation)	5G	12.45
Shaft Assembly*		
Airweight	16A	29.10
Black	16B	20.90
Chrome	16C	18.25
Electroless	16E	20.65
Gold (Presentation)	16G	43.95
Cap		
Black	6	2.30
Electroless	6E	1.95
Airweight	49	2.95
Retaining Clip Assembly** (WA)		
Washer	7	1.10
Retaining Clip	19	.25
Rivet	201	.15
Grip	8	1.60
O-Ring	204	.05
Tape	209	5.00/roll

* Shaft Assembly consists of the Middle Tube, End Tube and Tip
 ** Retaining Clip Assembly consists of the Washer, Retaining Clip and Rivet

F21 DATABASE

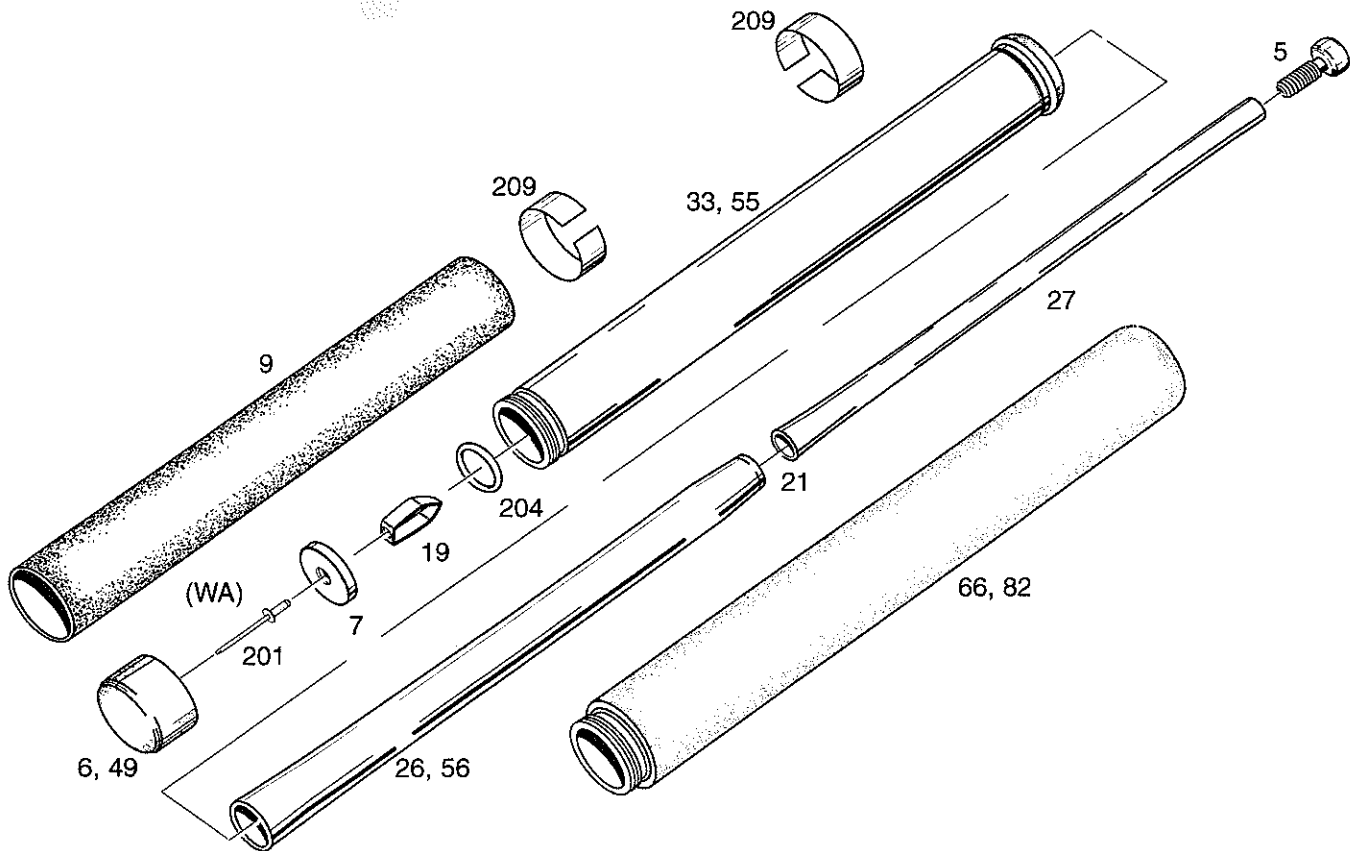
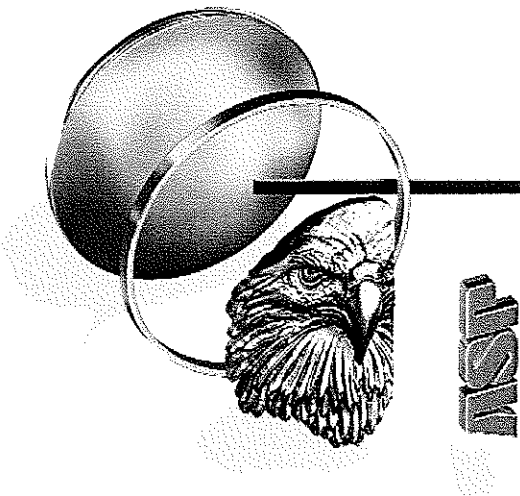

Handle		
Black	33	24.10
Electroless	33E	25.60
Airweight (Aluminum)	55	23.55
Federal	66	20.55
DuraTec (Aluminum)	82	18.50
Middle Tube		
Black	26B	11.55
Chrome	26C	10.35
Electroless	26E	11.95
Gold (Presentation)	26G	28.10
Airweight	56	19.50
End Tube		
Black	27B	13.00
Chrome	27C	11.80
Electroless	27E	13.10
Gold (Presentation)	27G	29.60

Tip		
Black	5B	1.40
Chrome	5C	1.15
Electroless	5E	.95
Gold (Presentation)	5G	12.45
Shaft Assembly*		
Airweight	21A	33.90
Black	21B	25.95
Chrome	21C	23.30
Electroless	21E	26.00
Gold (Presentation)	21G	70.15
Cap		
Black	6	2.30
Electroless	6E	1.95
Airweight	49	2.95
Retaining Clip Assembly** (WA)		
Washer	7	1.10
Retaining Clip	19	.25
Rivet	201	.15
Grip	9	1.90
O-Ring	204	.05
Tape	209	5.00 /roll

* Shaft Assembly consists of the Middle Tube, End Tube and Tip
 ** Retaining Clip Assembly consists of the Washer, Retaining Clip and Rivet

F26

DATABASE

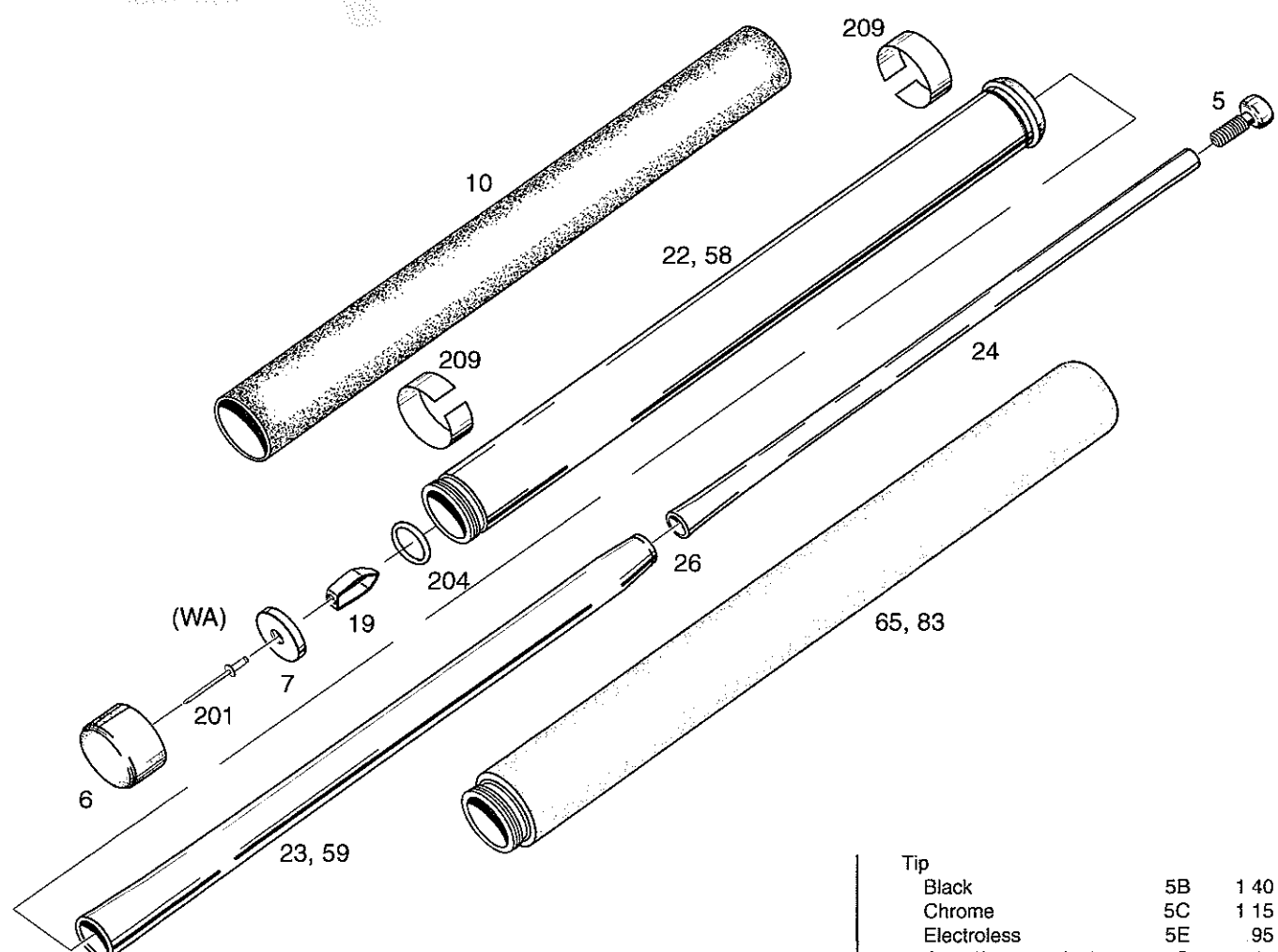
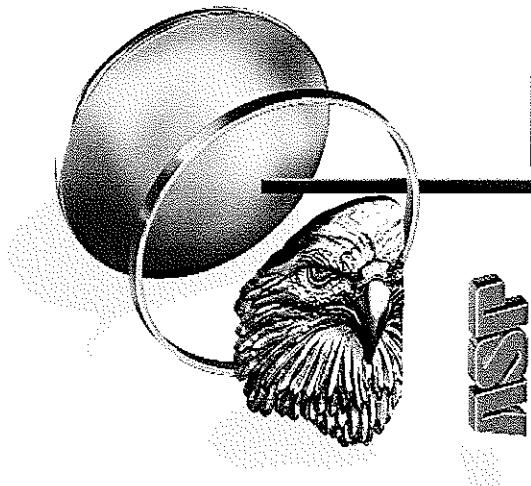

Handle		
Black	22	26.25
Electroless	22E	27.90
Airweight (Aluminum)	58	26.35
Federal	65	22.80
DuraTec (Aluminum)	83	22.05
Middle Tube		
Black	23B	13.00
Chrome	23C	11.85
Electroless	23E	13.30
Gold (Presentation)	23G	30.75
Airweight	59	22.75
End Tube		
Black	24B	14.50
Chrome	24C	13.35
Electroless	24E	14.75
Gold (Presentation)	24G	31.50

Tip		
Black	5B	1.40
Chrome	5C	1.15
Electroless	5E	.95
Gold (Presentation)	5G	12.45
Shaft Assembly*		
Airweight	26A	38.65
Black	26B	28.90
Chrome	26C	26.35
Electroless	26E	29.00
Gold (Presentation)	26G	74.70
Cap		
Black	6	2.30
Electroless	6E	1.95
Airweight	49	2.95
Retaining Clip Assembly** (WA)		1.50
Washer	7	1.10
Retaining Clip	19	.25
Rivet	201	.15
Grip	10	2.00
O-Ring	204	.05
Tape	209	5.00/roll

* Shaft Assembly consists of the Middle Tube End Tube and Tip
 ** Retaining Clip Assembly consists of the Washer, Retaining Clip and Rivet



Box 1794 · Appleton, WI 54912 · (920) 735-6242 Fax (920) 735-6245 · asp-usa.com

LeverLoc Baton

TECHNICAL SPECIFICATIONS

	L16	L21	L26
Material	4140 Alloy Steel (Airweights 7075)		
Tubing Designation	Seamless		
Striking Surface	49+ Rockwell C-Scale		
Diameter	1 <i>25.4mm</i>	1 <i>25.4mm</i>	1 <i>25.4mm</i>
Length Closed	7.25 <i>18.415cm</i>	8.75 <i>22.225cm</i>	10.61 <i>26.95cm</i>
Length Expanded	15.312 <i>38.9cm</i>	19.75 <i>50.16cm</i>	25.312 <i>64.30cm</i>
Steel Weight	16.6 <i>471g</i>	20.8 <i>589g</i>	24.0 <i>680g</i>
Airweight Weight	9.13 <i>259g</i>	10.9 <i>309g</i>	13.0 <i>369g</i>
Handle			
Surface	Foam, DuraTec, Wavemaster		
Tubing	7/8 OD x 14 Gauge (.083) <i>22.4mm OD x 14 Gauge (2mm)</i>		
Dimensions	6.75 <i>17.15cm</i>	8.25 <i>20.95cm</i>	10.07 <i>25.58cm</i>
Coating	Textured Powdered Paint		
Corrosion Resistance	Electroless (Black Anodized)		
Middle Shaft			
Tubing	21/32 OD x 13 Gauge (.095) <i>1.67mm OD x 13 Gauge (2.4mm)</i>		
Dimensions	5.80 <i>14.73cm</i>	7.30 <i>18.54cm</i>	9.13 <i>23.19cm</i>
Coating	Electroless		
End Shaft			
Tubing	7/16 OD x 14 Gauge (.083) <i>10.9mm OD x 14 Gauge (2.0mm)</i>		
Dimensions	4.12 <i>10.46cm</i>	5.62 <i>14.27cm</i>	7.45 <i>18.92cm</i>
Coating	Electroless		
Cap			
Coating	Textured Powdered Paint		
Corrosion Resistance	Yellow Zinc Dichromate (Black Anodized)		
O-Ring Sealed	Internal		
Retention Clip	Assembly	Assembly	Assembly

NOTE: Metric measurements are printed in italic.

L16

DATABASE

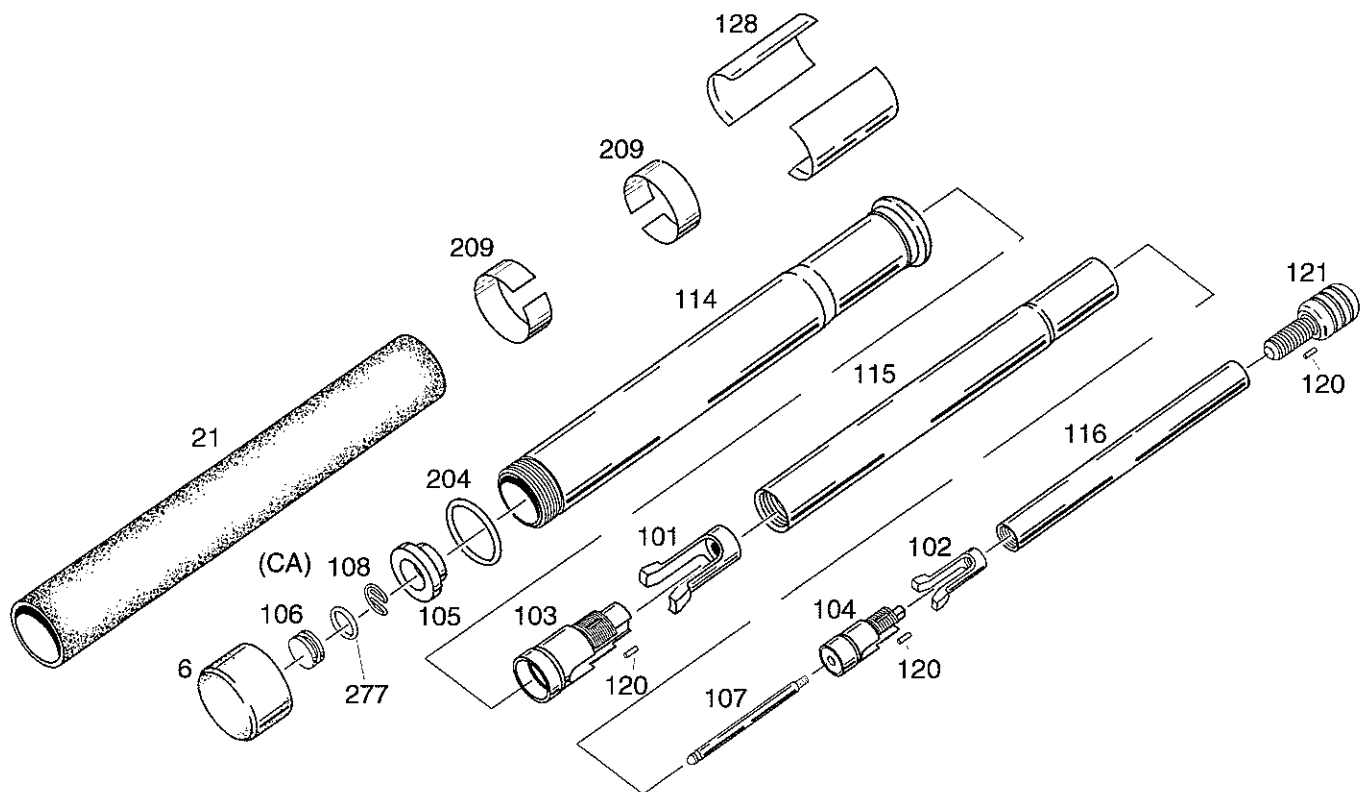
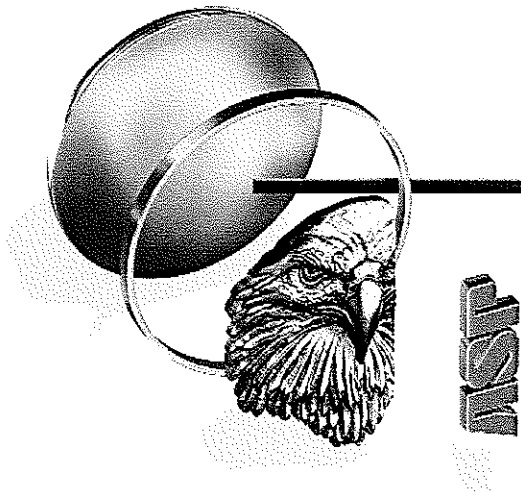

Handle			
Black	114B	28.00	
Electroless	114E	26.00	
Middle Tube			
Black	115B	18.00	
Chrome	115C	18.00	
Electroless	115E	20.00	
End Tube			
Black	116B	12.00	
Chrome	116C	12.00	
Electroless	116E	14.00	
Tip			
Black	121B	3.00	
Chrome	121C	3.00	
Electroless	121E	4.00	
Shaft Assembly*			
Black	LL16B	77.50	
Chrome	LL16C	77.50	
Electroless	LL16E	82.50	

Cap			
Black	6	2.30	
Electroless	6E	1.95	
Retaining Clip Assembly** (CA)		6.55	
Clip Disk	105	3.50	
Clip Disk Spacer	106	2.00	
Wire Retaining Clip	108	1.00	
O-Ring	277	.05	
Retaining Rod	107	3.00	
Large Spring	101	14.00	
Small Spring	102	12.00	
Large Plug	103	10.00	
Small Plug	104	8.00	
Nylon Thread Lock	120	.10	
O-Ring	204	.05	
Grip	21	2.50	
Tape	209	5.00/roll	
Spacer Sleeves	128	1.00/set	

* Shaft Assembly consists of the Middle Tube, End Tube, Tip, Springs and Plugs
 ** Retaining Clip Assembly consists of the Clip Disk Clip Disk Spacer, Wire Retaining Clip and O-Ring

L21 DATABASE

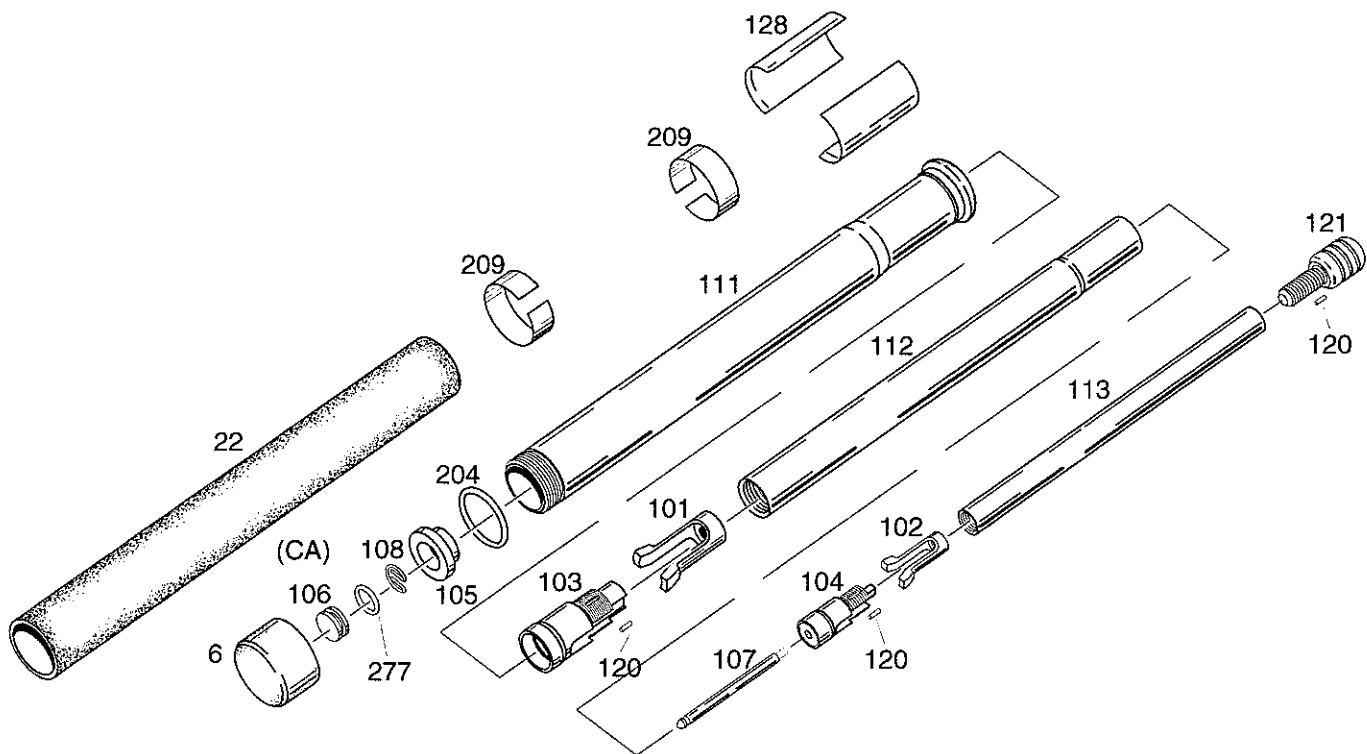
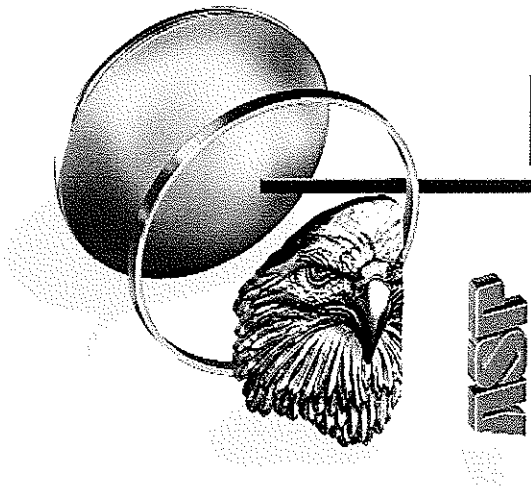

Handle			
Black	111B	30.00	
Electroless	111E	28.00	
Middle Tube			
Black	112B	20.00	
Chrome	112C	20.00	
Electroless	112E	22.00	
End Tube			
Black	113B	13.00	
Chrome	113C	13.00	
Electroless	113E	15.00	
Tip			
Black	121B	3.00	
Chrome	121C	3.00	
Electroless	121E	4.00	
Shaft Assembly*			
Black	LL21B	80.50	
Chrome	LL21C	80.50	
Electroless	LL21E	85.50	

Cap			
Black	6	2.30	
Electroless	6E	1.95	
Retaining Clip Assembly** (CA)		6.55	
Clip Disk	105	3.50	
Clip Disk Spacer	106	2.00	
Wire Retaining Clip	108	1.00	
O-Ring	277	.05	
Retaining Rod	107	3.00	
Large Spring	101	14.00	
Small Spring	102	12.00	
Large Plug	103	10.00	
Small Plug	104	8.00	
Nylon Thread Lock	120	.10	
O-Ring	204	.05	
Grip	22	3.00	
Tape	209	5.00/roll	
Spacer Sleeves	128	1.00/set	

* Shaft Assembly consists of the Middle Tube, End Tube, Tip, Springs and Plugs

** Retaining Clip Assembly consists of the Clip Disk, Clip Disk Spacer, Wire Retaining Clip and O-Ring.

L26

DATABASE

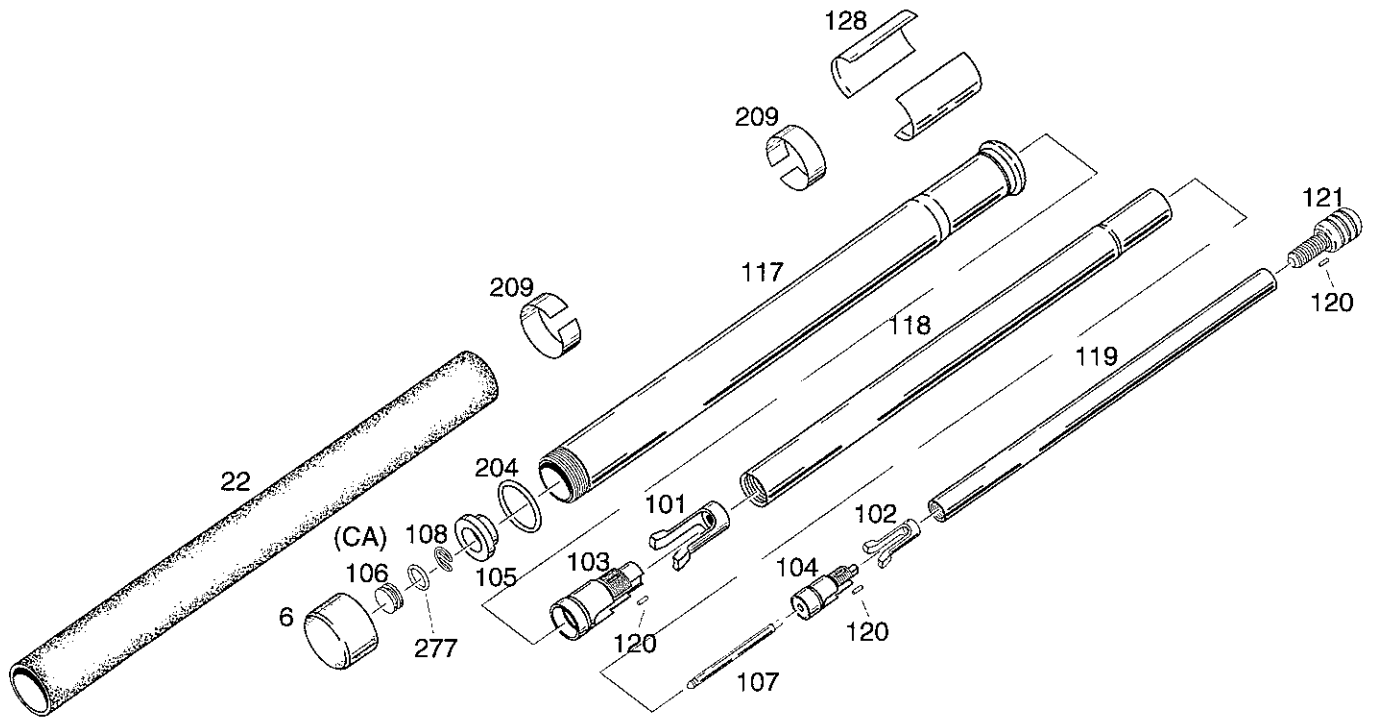
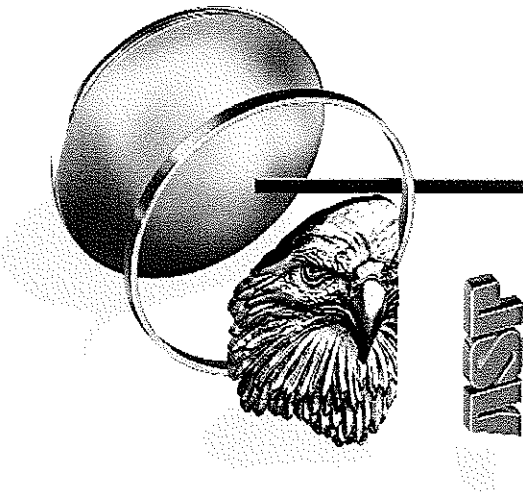

Handle			
Black	117B	32 00	
Electroless	117E	30 00	
Middle Tube			
Black	118B	21 00	
Chrome	118C	21 00	
Electroless	118E	23 00	
End Tube			
Black	119B	14 00	
Chrome	119C	14 00	
Electroless	119E	16 00	
Tip			
Black	121B	3 00	
Chrome	121C	3 00	
Electroless	121E	4 00	
Shaft Assembly*			
Black	LL26B	82 50	
Chrome	LL26C	82 50	
Electroless	LL26E	87 50	

Cap			
Black	6	2 30	
Electroless	6E	1 95	
Retaining Clip Assembly**	(CA)	6 55	
Clip Disk	105	3 50	
Clip Disk Spacer	106	2 00	
Wire Retaining Clip	108	1 00	
O-Ring	277	.05	
Retaining Rod	107	3 00	
Large Spring	101	14 00	
Small Spring	102	12 00	
Large Plug	103	10 00	
Small Plug	104	8 00	
Nylon Thread Lock	120	.10	
O-Ring	204	.05	
Grip	23	3 50	
Tape	209	5 00 /roll	
Spacer Sleeves	128	1 00 /set	

* Shaft Assembly consists of the Middle Tube, End Tube, Tip, Springs and Plugs.

** Retaining Clip Assembly consists of the Clip Disk, Clip Disk Spacer, Wire Retaining Clip and O-Ring.

16 SideBreak Slide Scabbard

DATABASE

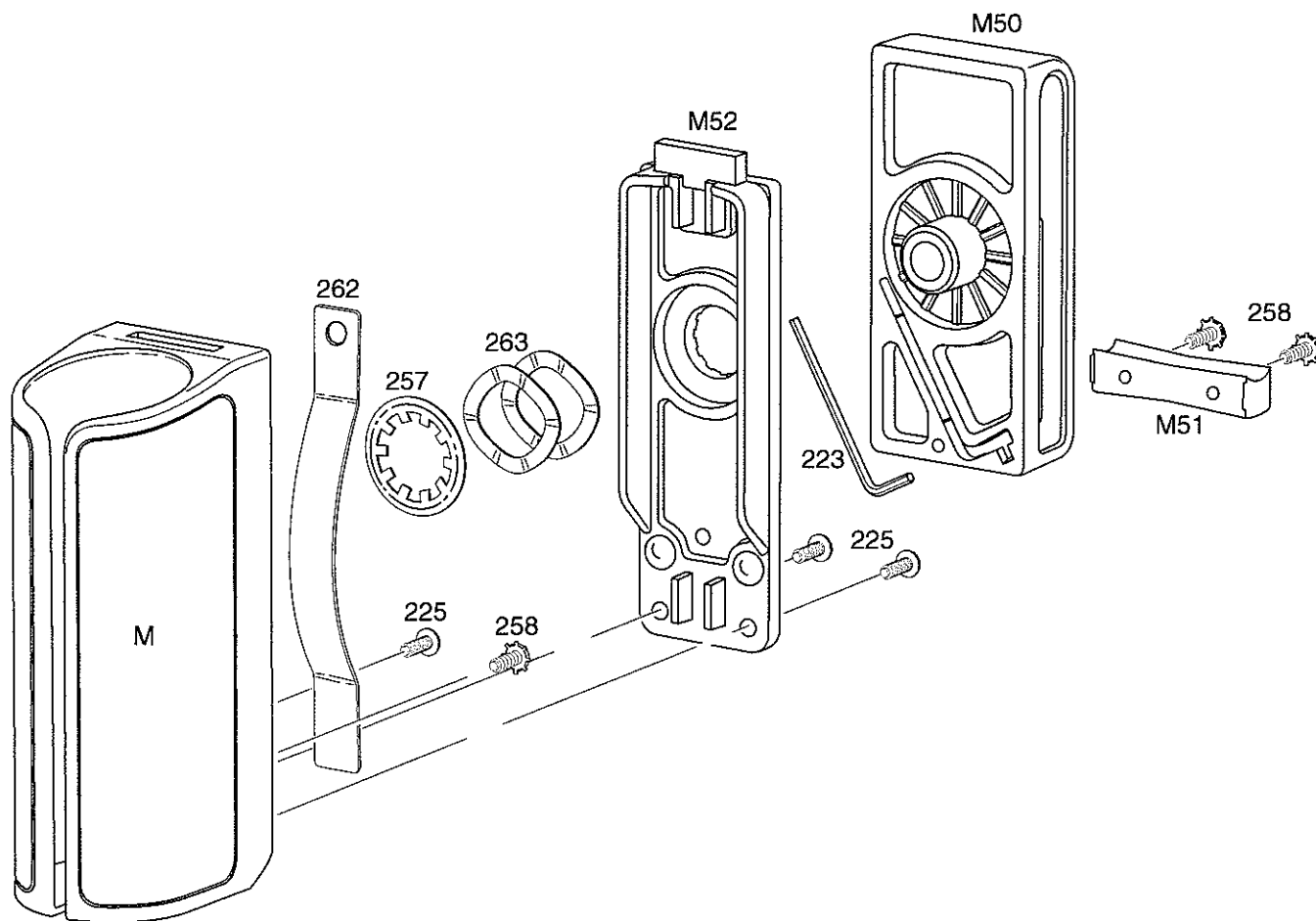
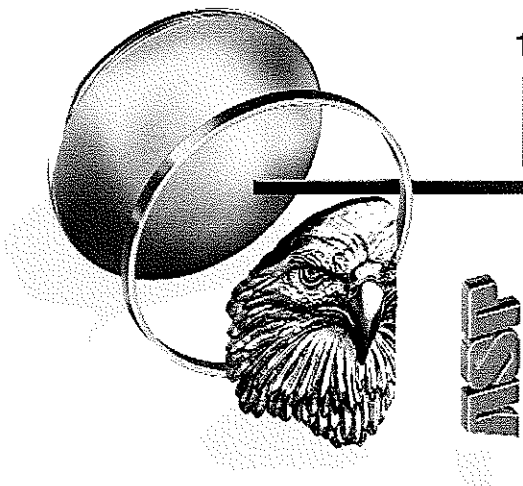

Rotating Belt Loop	M50	2 50
Slide Bar	M51	60
Back Plate	M52	1 80
Body		
Black	M53	5 20
Basketweave	M54	5 20
ASPTec	M55	5 20
Ballistic Weave	M56	5 20
Hex Key	223	25
Back Plate Screw	225	10
Lock Ring	257	20
Slide Bar Screw	258	25
Retention Clip	262	20
Wave Washer	263	25

16 SideBreak Clip Scabbard

DATABASE

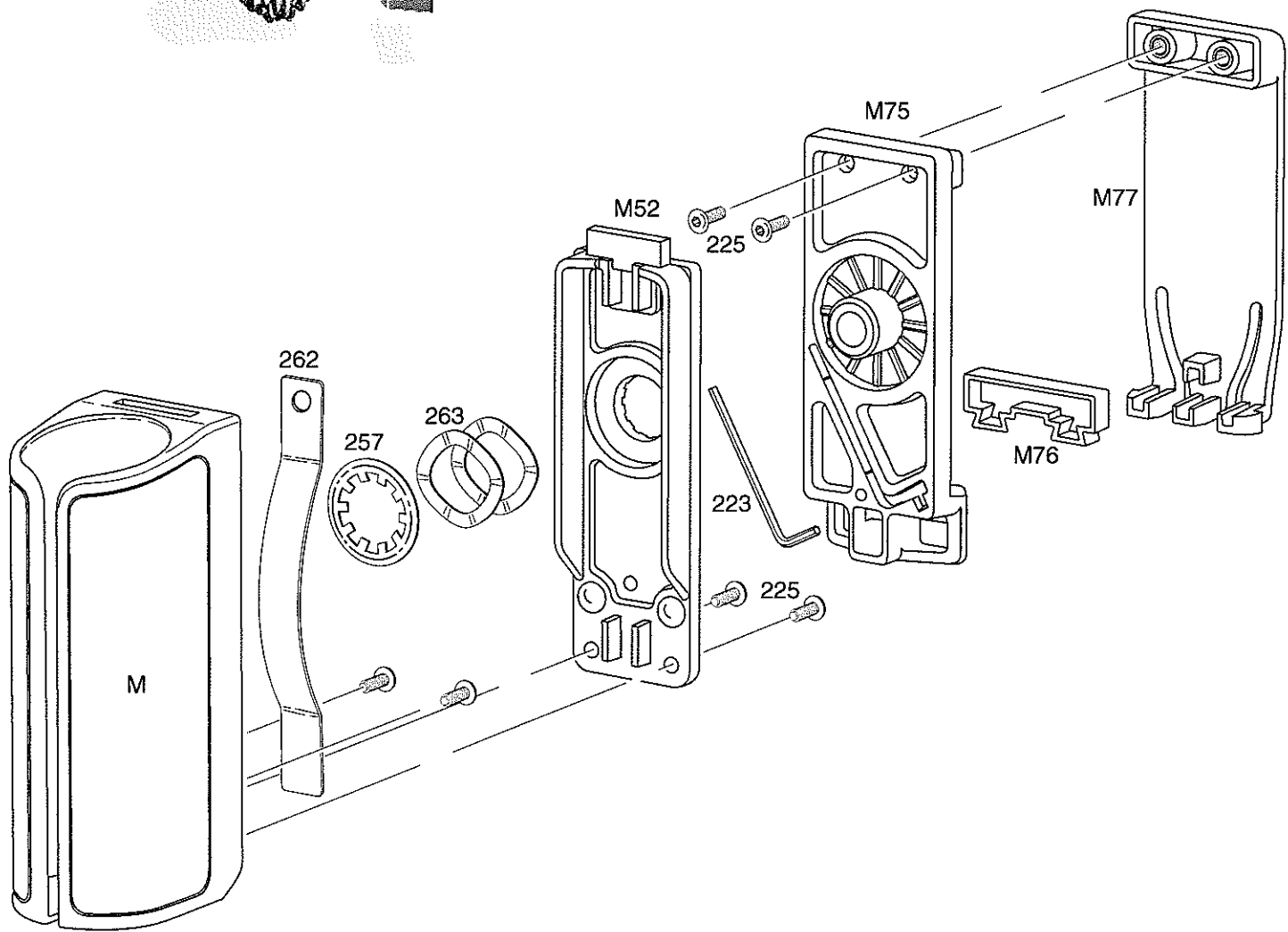
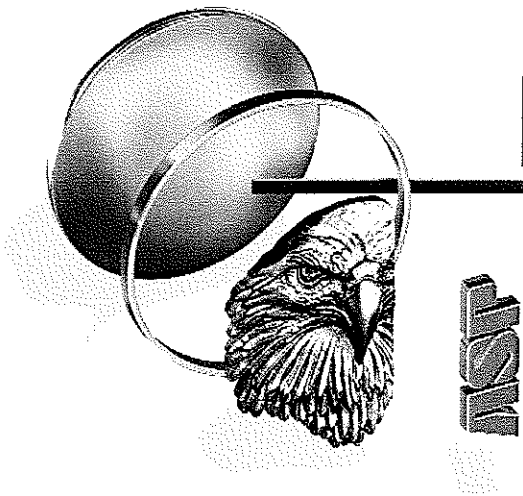

Back Plate	M52	1.80
Body		
Black	M53	5.20
Basketweave	M54	5.20
ASPtec	M55	5.20
Ballistic Weave	M56	5.20
Rotating Base	M75	2.50
2" Adjustment Block	M76	1.00
Belt Clip	M77	2.50
Hex Key	223	.25
Back Plate Screw	225	.10
Lock Ring	257	.20
Retention Clip	262	.20
Wave Washer	263	.25

16 SideBreak Paddle Scabbard

DATABASE

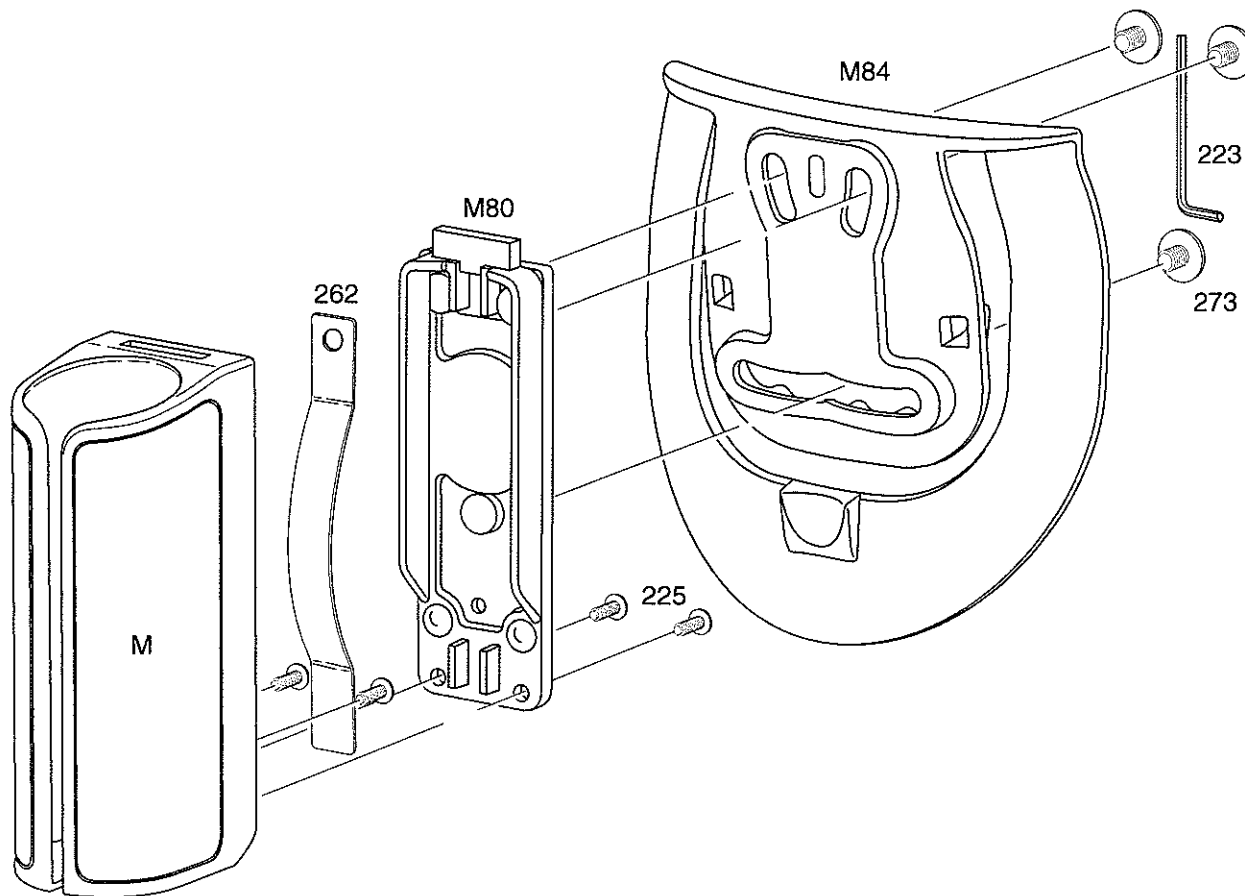
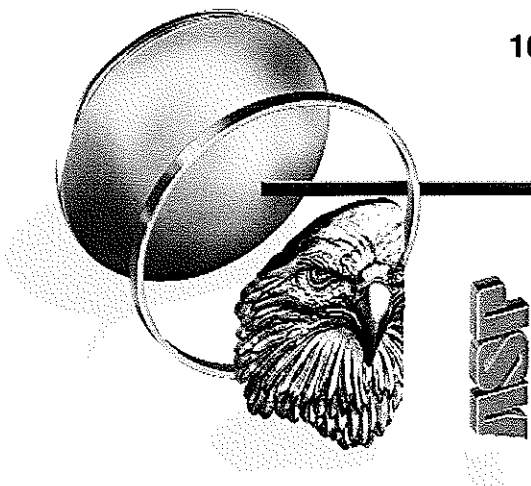

Body		
Black	M53	5.20
Basketweave	M54	5.20
ASPTec	M55	5.20
Ballistic Weave	M56	5.20
Back Plate	M80	1.80
Paddle	M84	5.00
Hex Key	223	.25
Back Plate Screw	225	.10
Retention Clip	262	.20
Adjustment Screw	273	.75

16 Federal Slide Scabbard
DATABASE

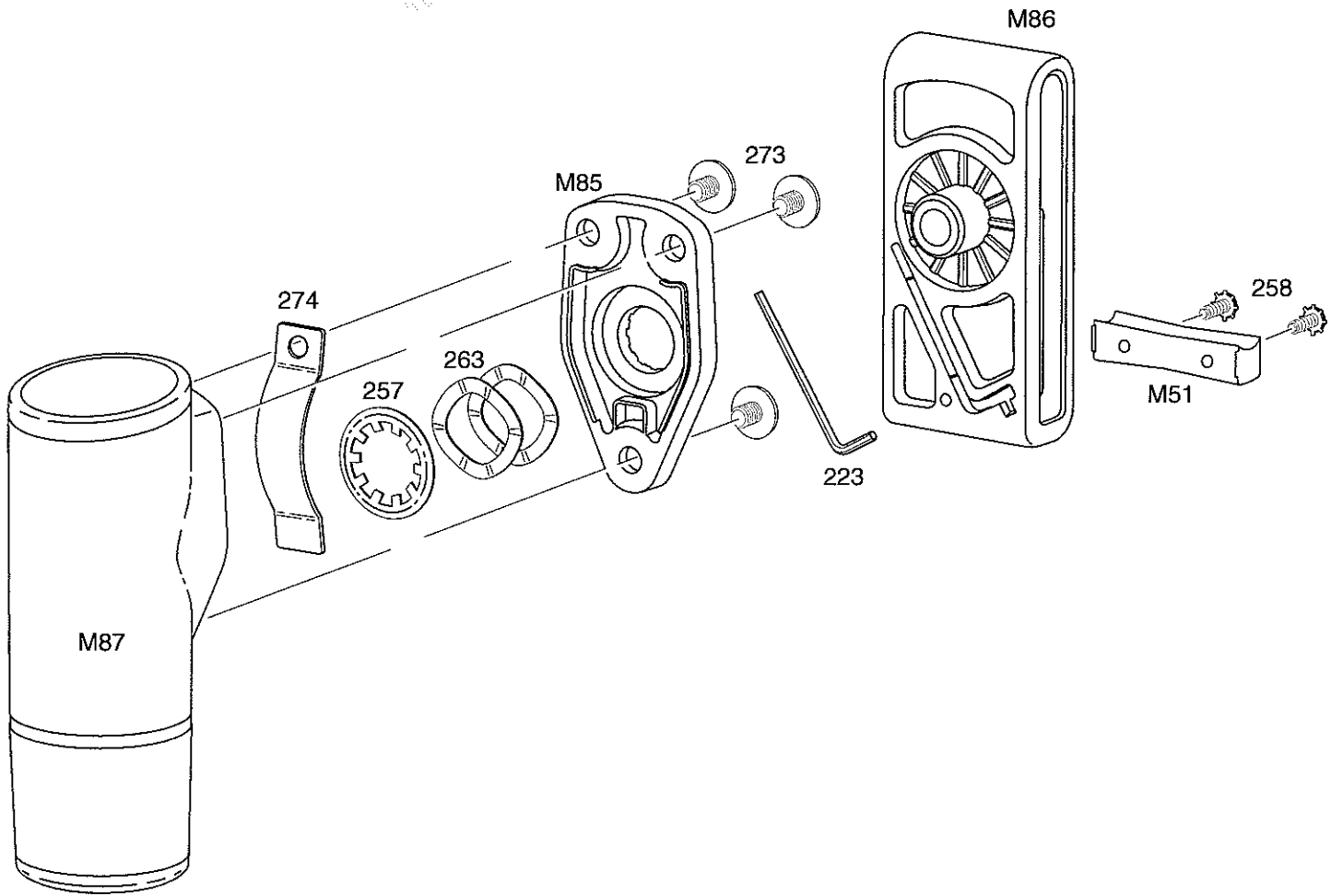
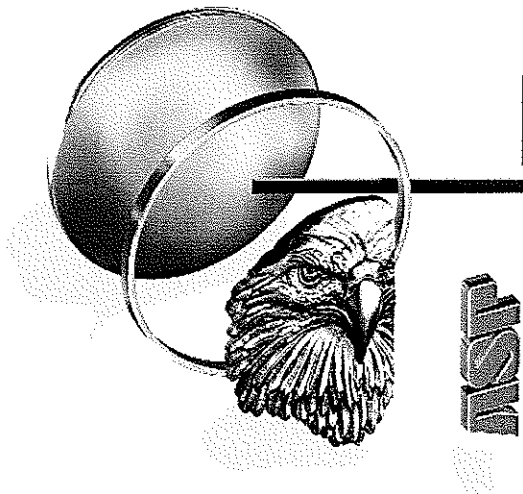

Slide Bar	M51	.60
Back Plate	M85	1.80
Belt Loop	M86	2.50
Body, Black	M87	5.20
Hex Key	223	.25
Lock Ring	257	.20
Slide Bar Screw	258	.25
Wave Washer	263	.25
Adjustment Screw	273	.75
Retention Clip	274	.20

DATABASE

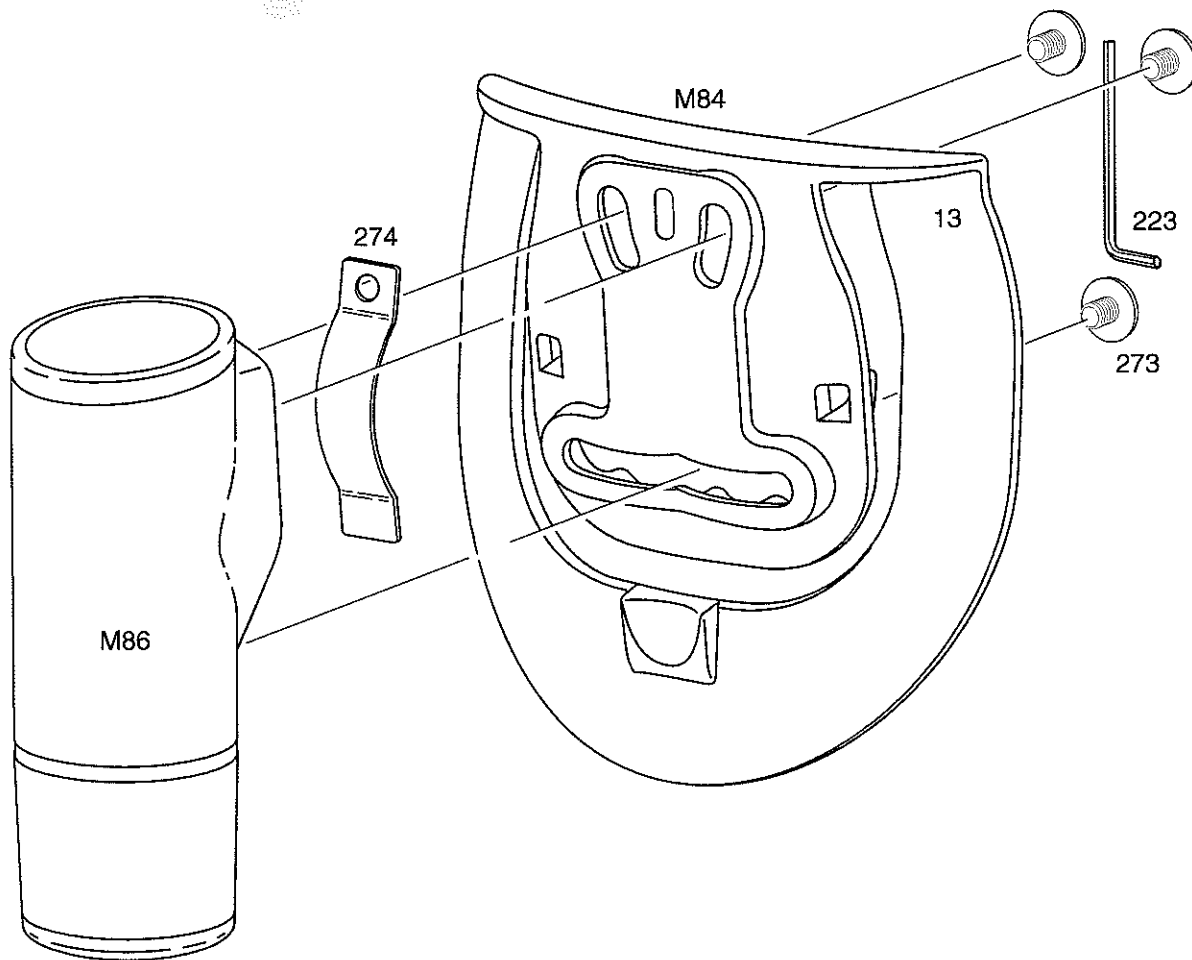
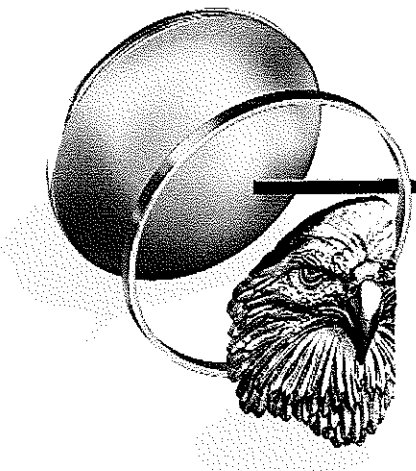

Paddle	M84	5 00
Body, Black	M86	5 20
Hex Key	223	25
Adjustment Screw	273	75
Retention Clip	274	20

21 SideBreak Slide Scabbard

DATABASE

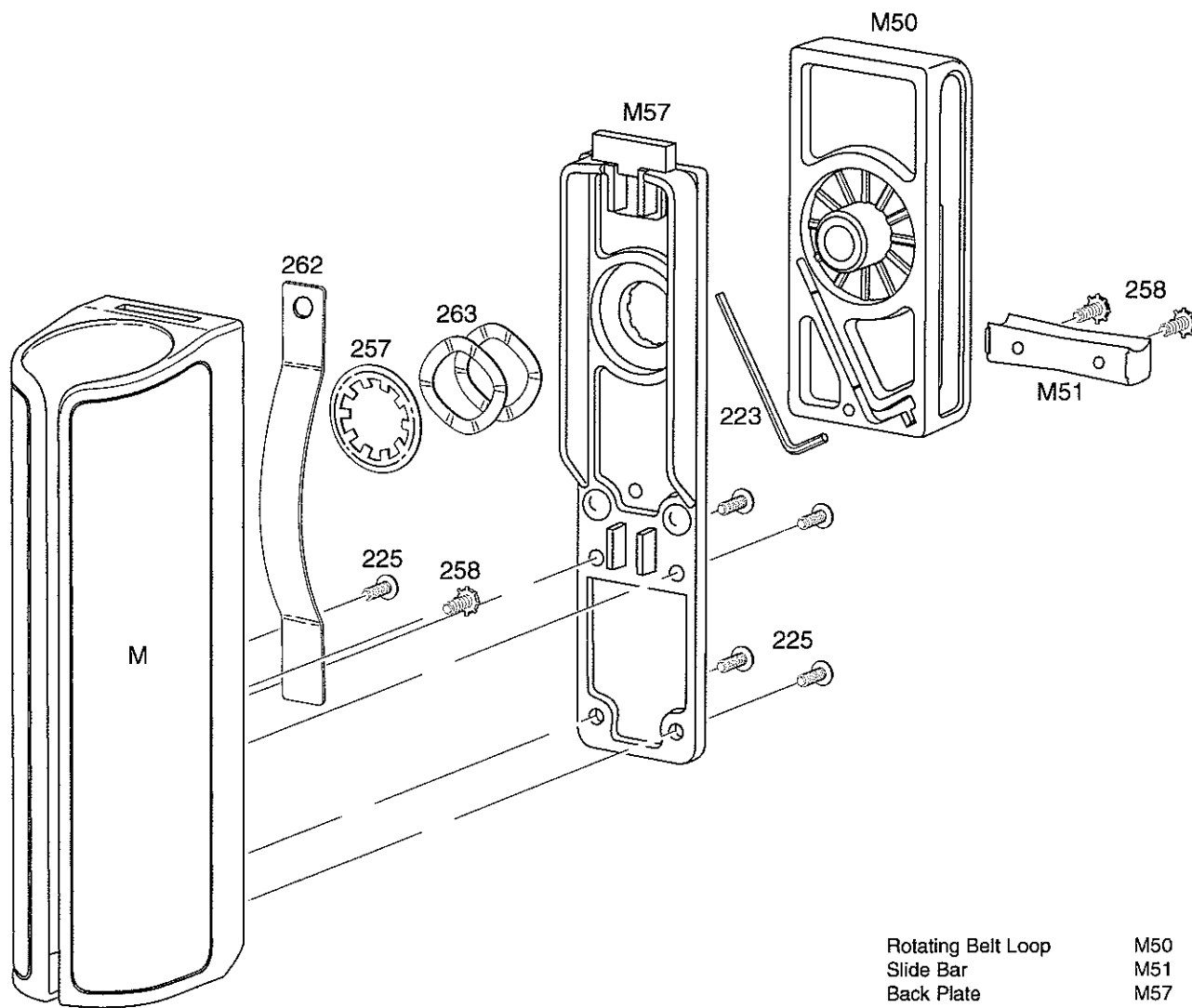
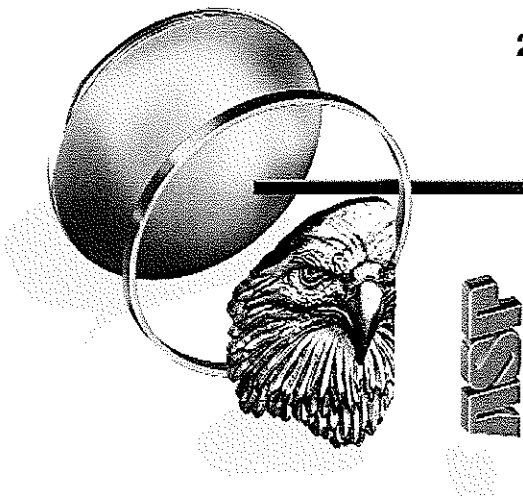

Rotating Belt Loop	M50	2 50
Slide Bar	M51	60
Back Plate	M57	1 90
Body		
Black	M58	5 35
Basketweave	M59	5 35
ASPtec	M60	5 35
Ballistic Weave	M61	5 35
Hex Key	223	25
Back Plate Screw	225	10
Lock Ring	257	.20
Slide Bar Screw	258	.25
Retention Clip	262	.20
Wave Washer	263	.25

21 SideBreak Clip Scabbard

DATABASE

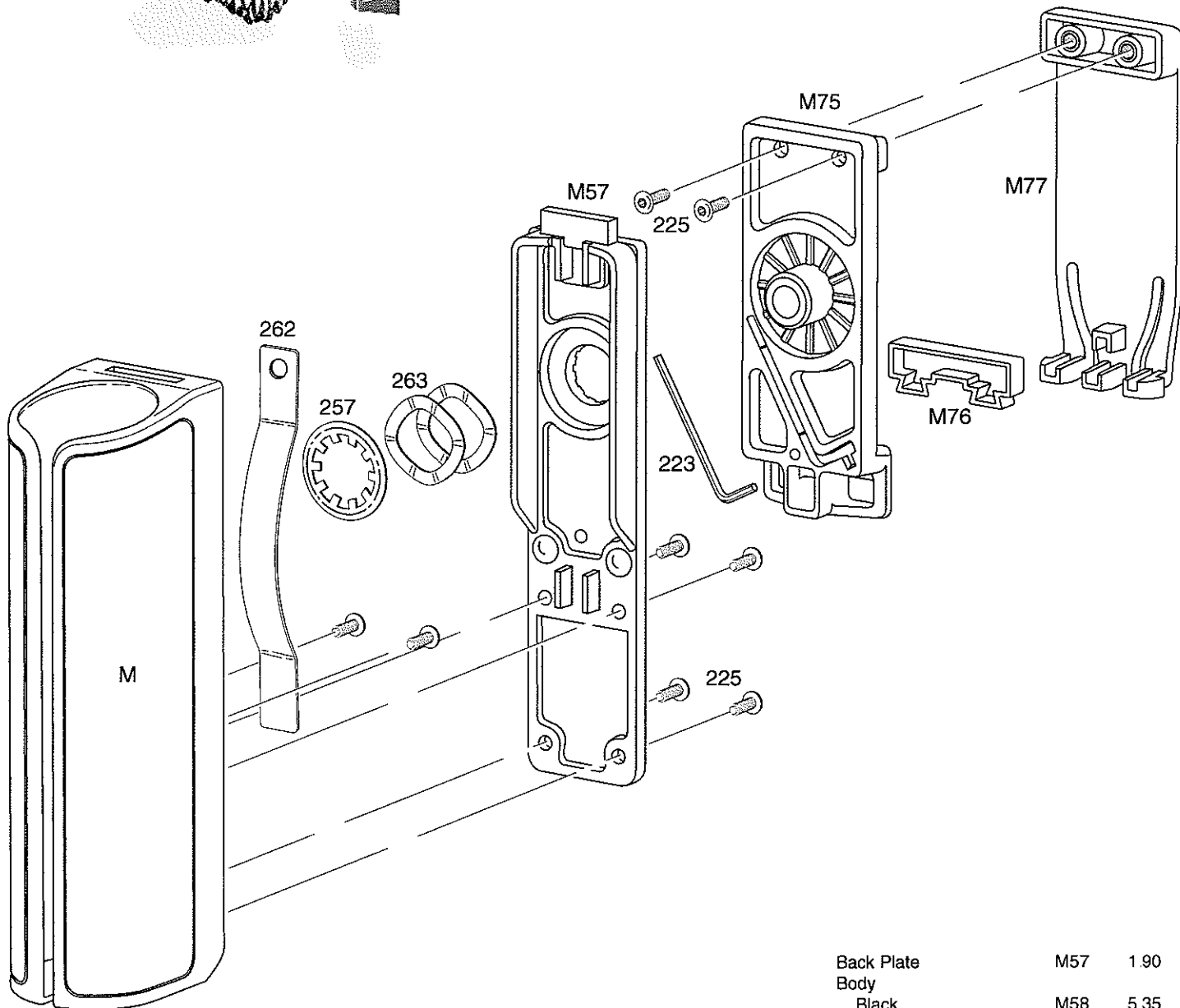
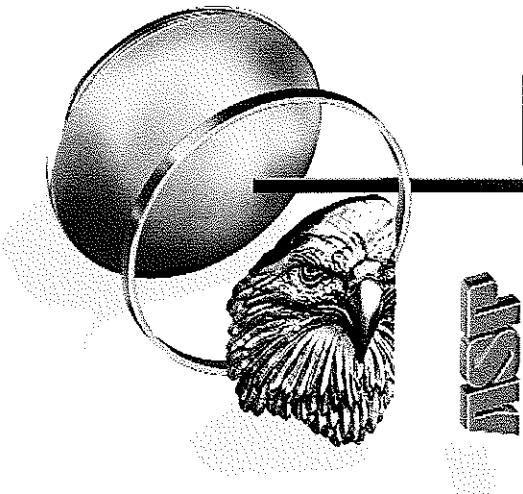

Back Plate	M57	1 90
Body		
Black	M58	5 35
Basketweave	M59	5 35
ASPTec	M60	5 35
Ballistic Weave	M61	5 35
Rotating Base	M75	2 50
2" Adjustment Block	M76	1 00
Belt Clip	M77	2 50
Hex Key	223	25
Back Plate Screw	225	10
Lock Ring	257	20
Retention Clip	262	20
Wave Washer	263	25

21 SideBreak Paddle Scabbard

DATABASE

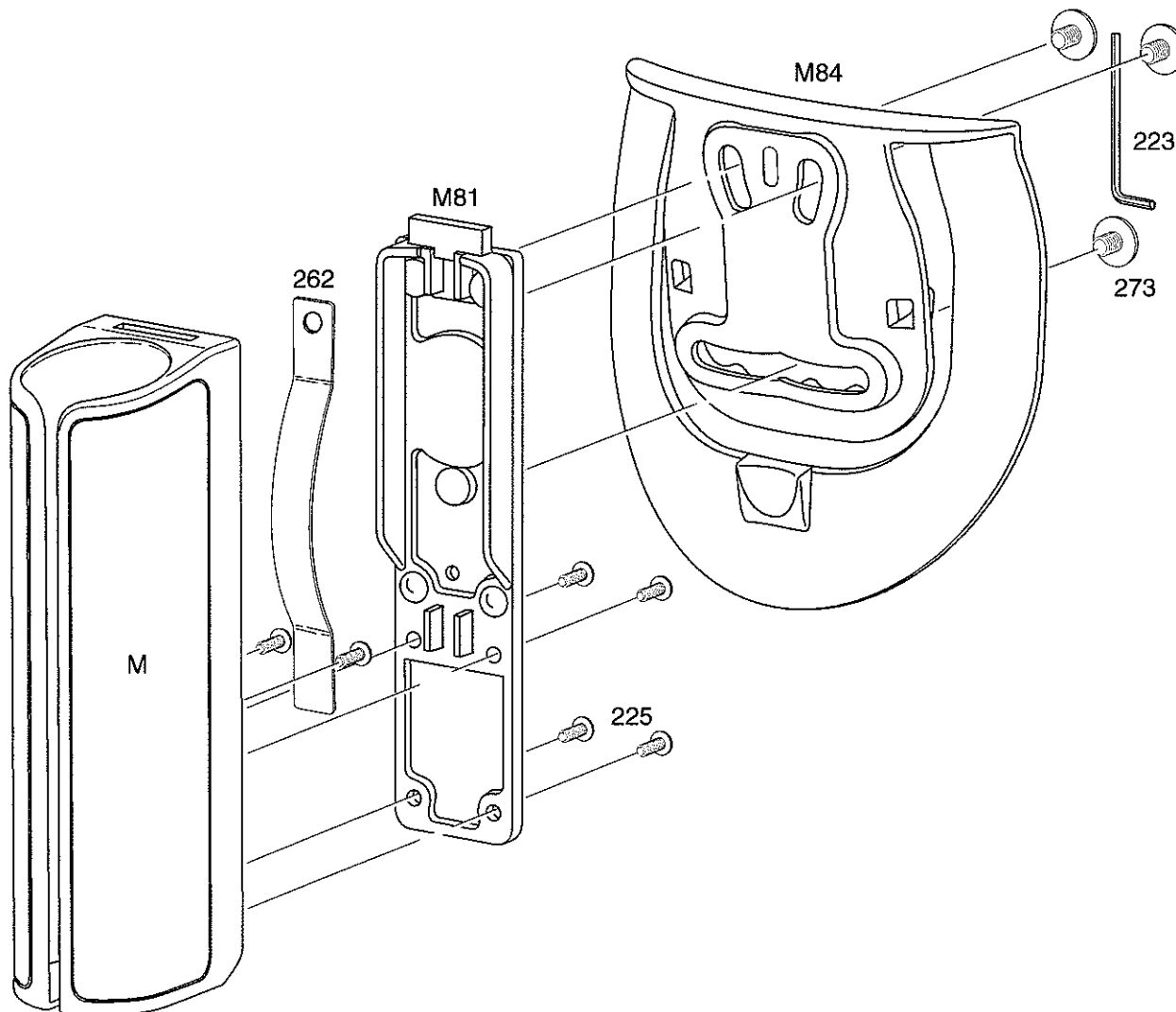
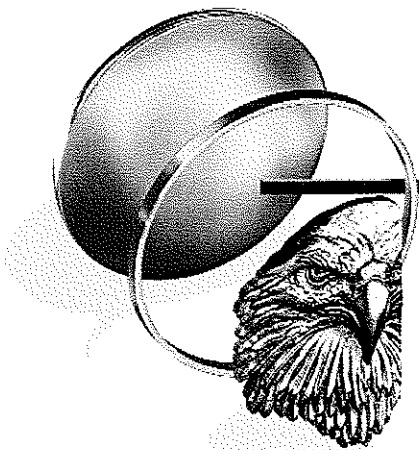

Body		
Black	M58	5.35
Basketweave	M59	5.35
ASPTec	M60	5.35
Ballistic Weave	M61	5.35
Back Plate	M81	1.90
Paddle	M84	5.00
Hex Key	223	.25
Back Plate Screw	225	.10
Retention Clip	262	.20
Adjustment Screw	273	.75

21 Federal Slide Scabbard DATABASE

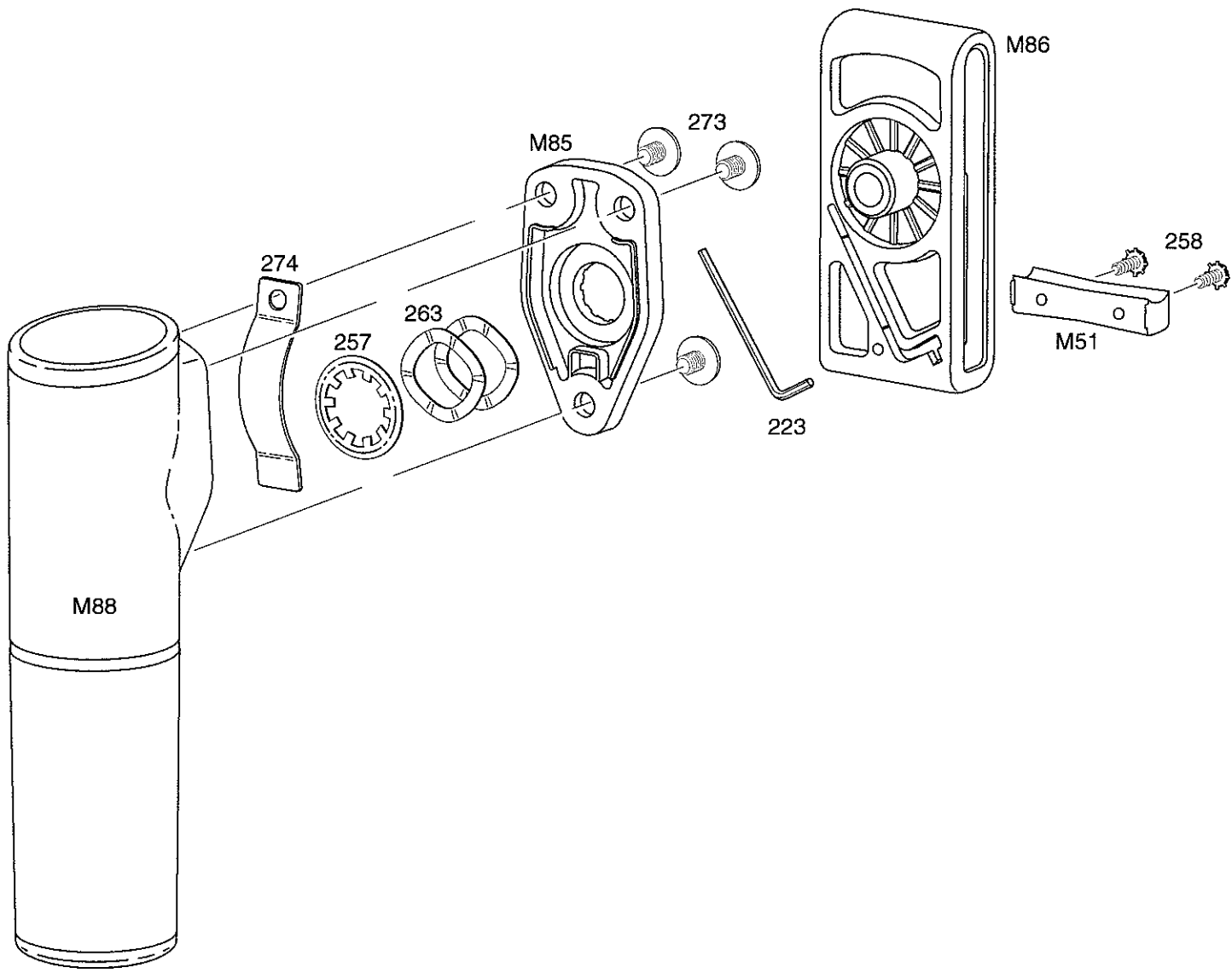
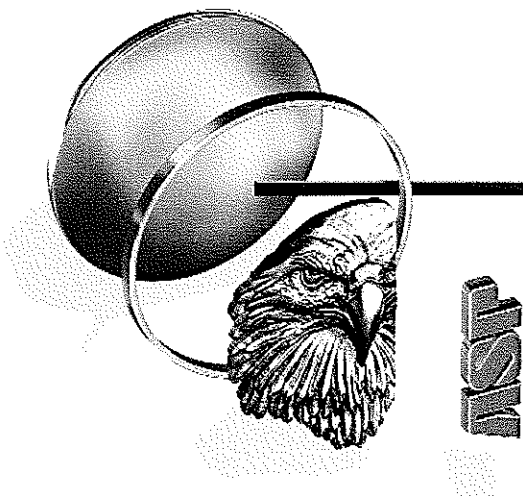

Slide Bar	M51	.60
Back Plate	M85	1.80
Rotating Belt Loop	M86	2.50
Body, Black	M88	5.35
Hex Key	223	.25
Lock Ring	257	.20
Slide Bar Screw	258	.25
Wave Washer	263	.25
Adjustment Screw	273	.75
Retention Clip	274	.20

21 Federal Paddle Scabbard

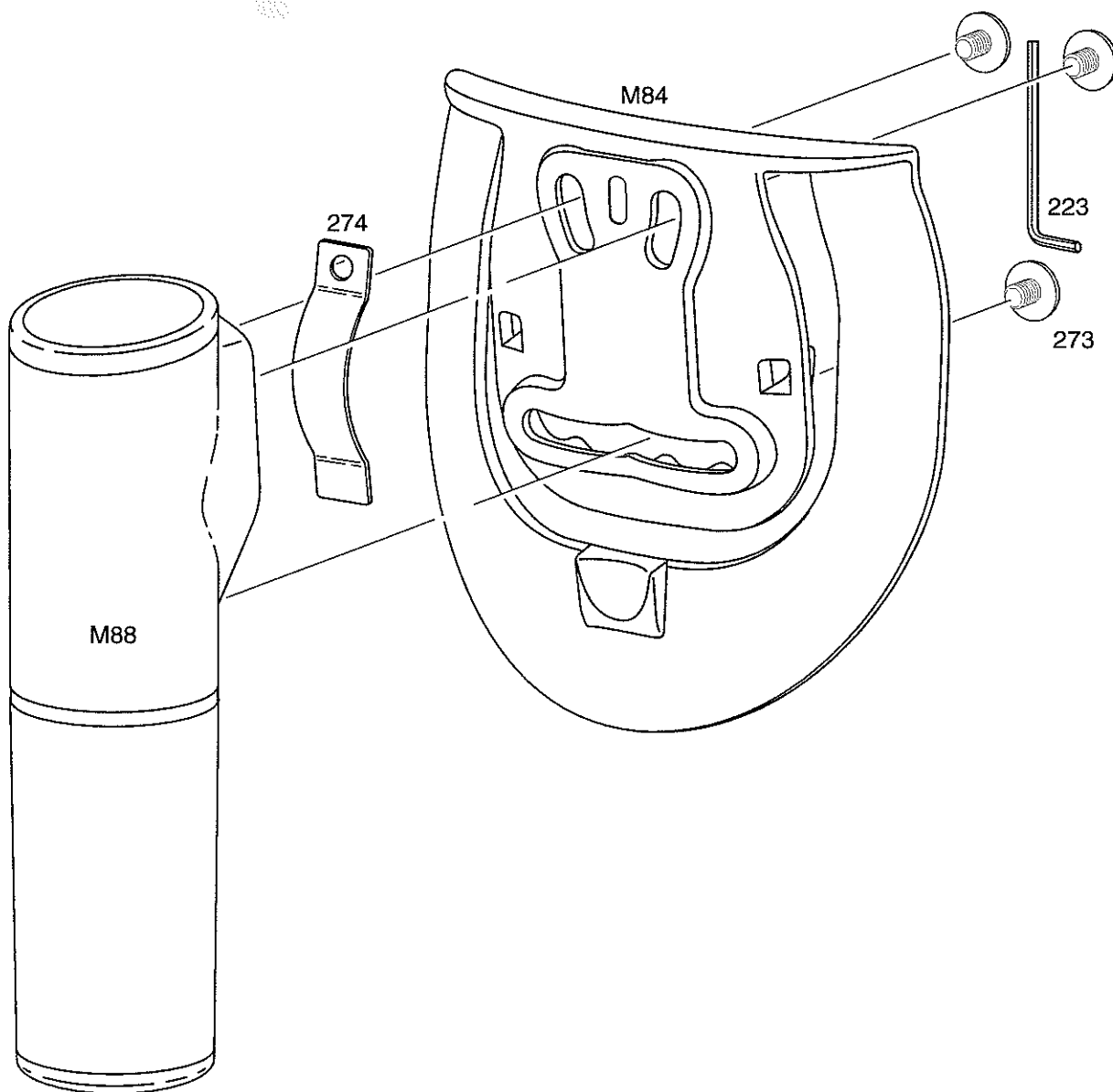
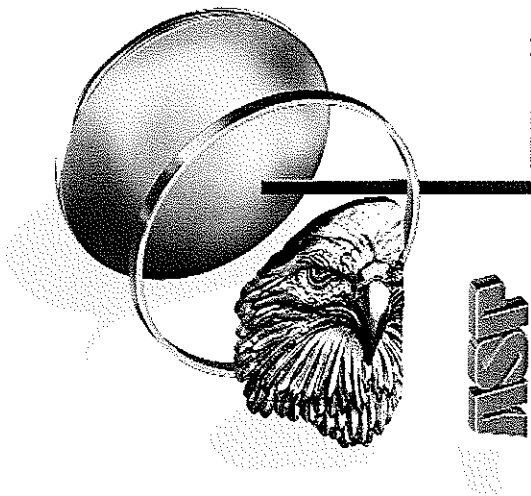
DATABASE

Paddle	M84	5.00
Body, Black	M88	5.35
Hex Key	223	.25
Adjustment Screw	273	.75
Retention Clip	274	.20

26 SideBreak Slide Scabbard

DATABASE

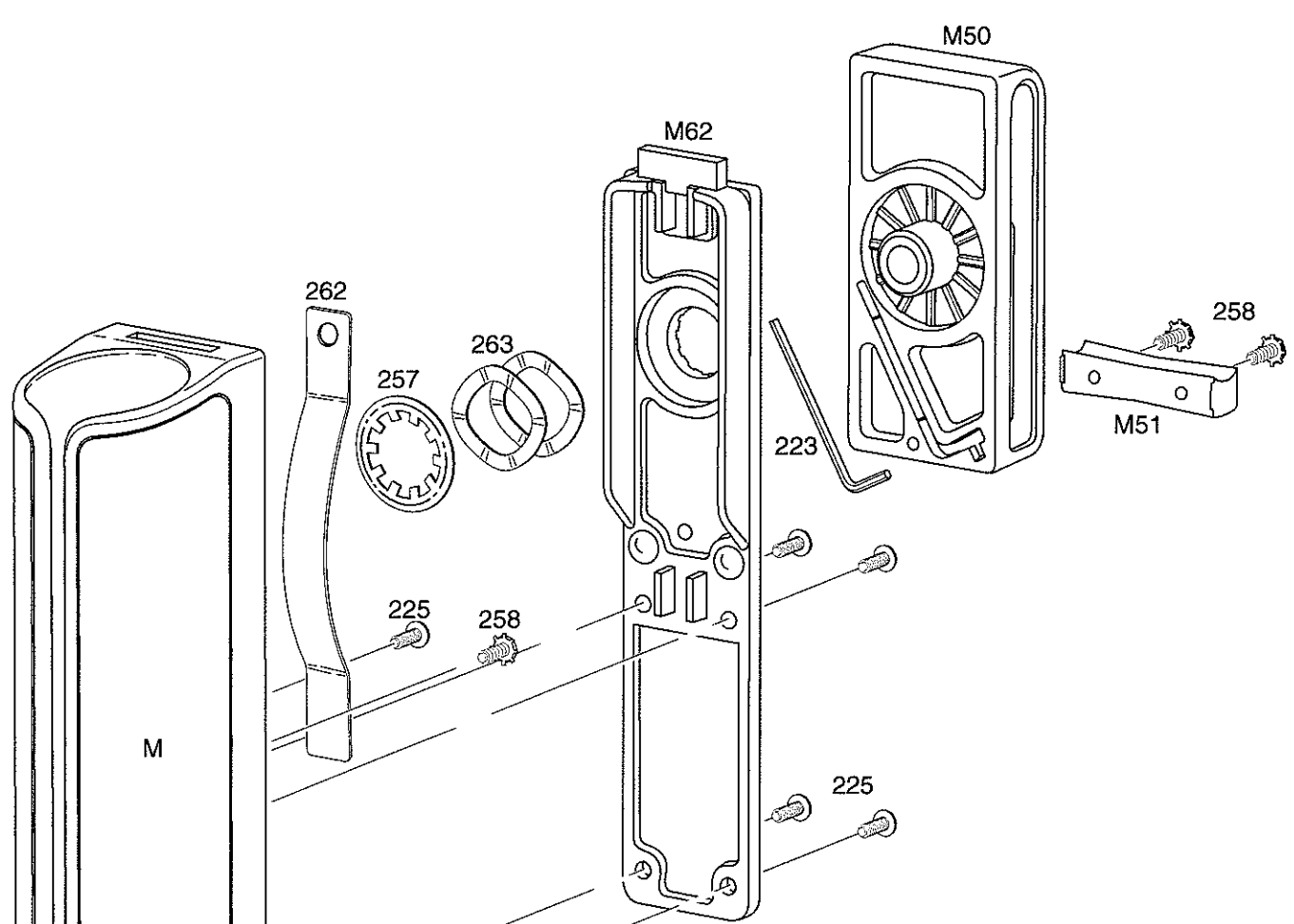
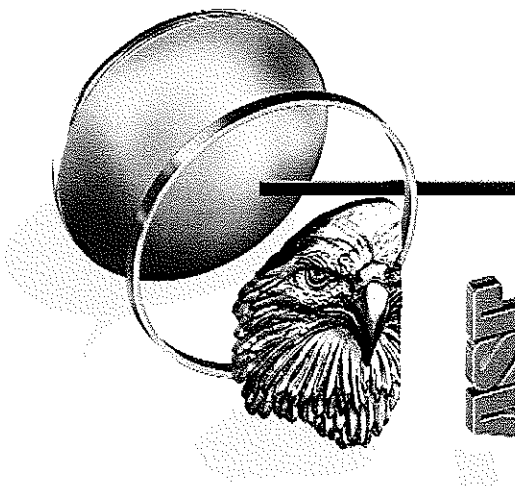

Rotating Belt Loop	M50	2.50
Slide Bar	M51	.60
Back Plate	M62	2.00
Body		
Black	M63	6.30
Basketweave	M64	6.30
ASPtec	M65	6.30
Ballistic Weave	M66	6.30
Hex Key	223	.25
Back Plate Screw	225	.10
Lock Ring	257	.20
Slide Bar Screw	258	.25
Retention Clip	262	.20
Wave Washer	263	.25

26 SideBreak Clip Scabbard

DATABASE

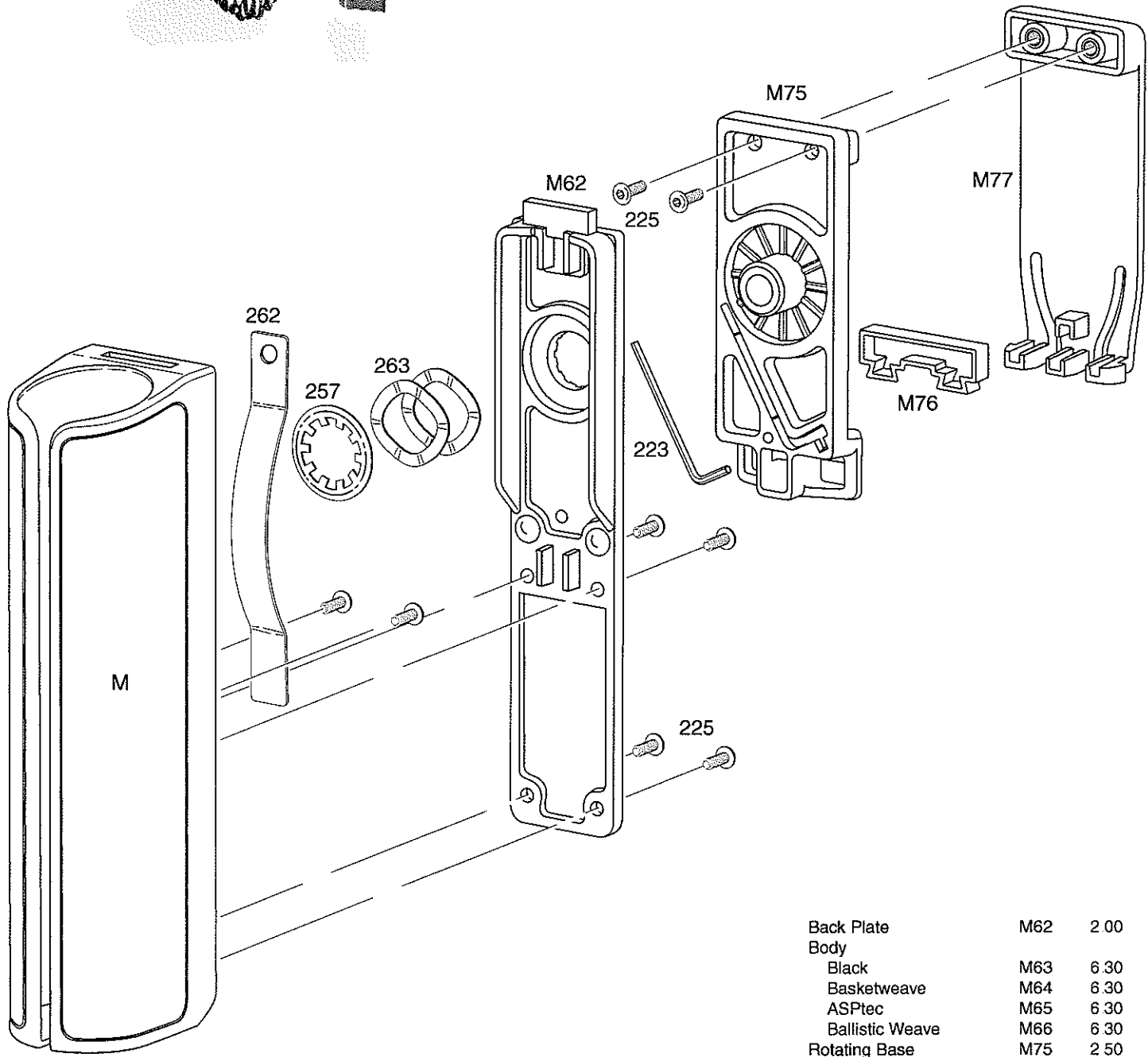
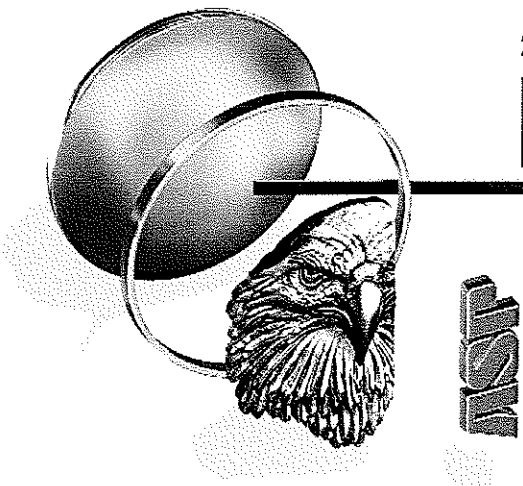

Back Plate	M62	2 00
Body		
Black	M63	6 30
Basketweave	M64	6 30
ASPTec	M65	6 30
Ballistic Weave	M66	6 30
Rotating Base	M75	2 50
2" Adjustment Block	M76	1 00
Belt Clip	M77	2 50
Hex Key	223	25
Back Plate Screw	225	10
Lock Ring	257	20
Retention Clip	262	20
Wave Washer	263	25

26 SideBreak Paddle Scabbard

DATABASE

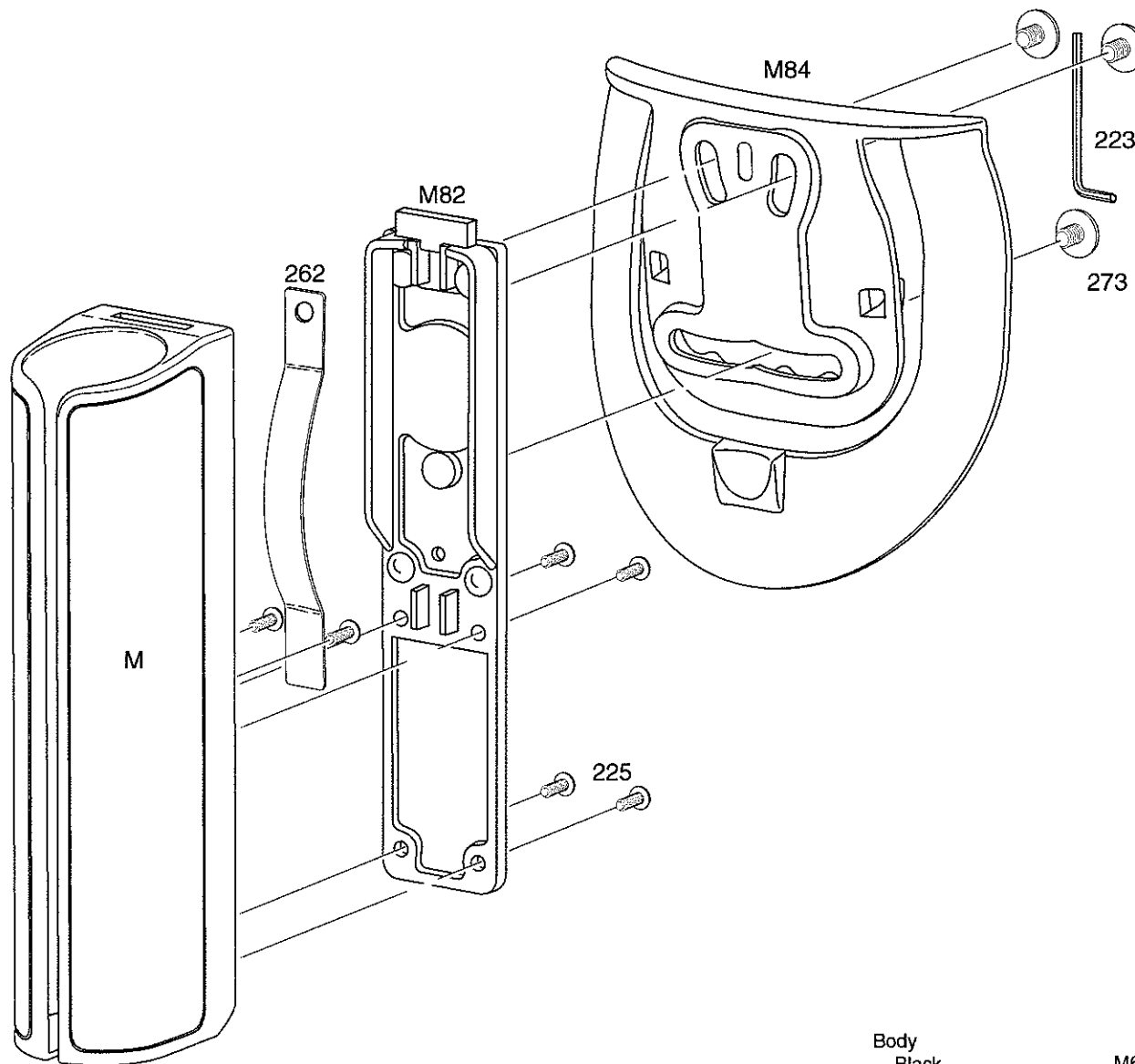
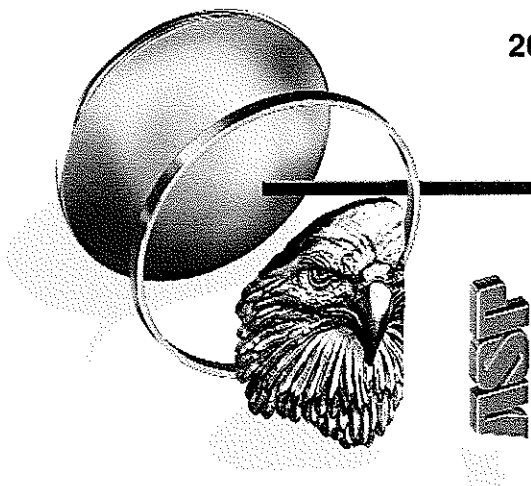

Body		
Black	M63	6.30
Basketweave	M64	6.30
ASPtec	M65	6.30
Ballistic Weave	M66	6.30
Back Plate	M82	2.00
Paddle	M84	5.00
Hex Key	223	.25
Belt Plate Screw	225	.10
Retention Clip	262	.20
Adjustment Screw	273	.75

DATABASE

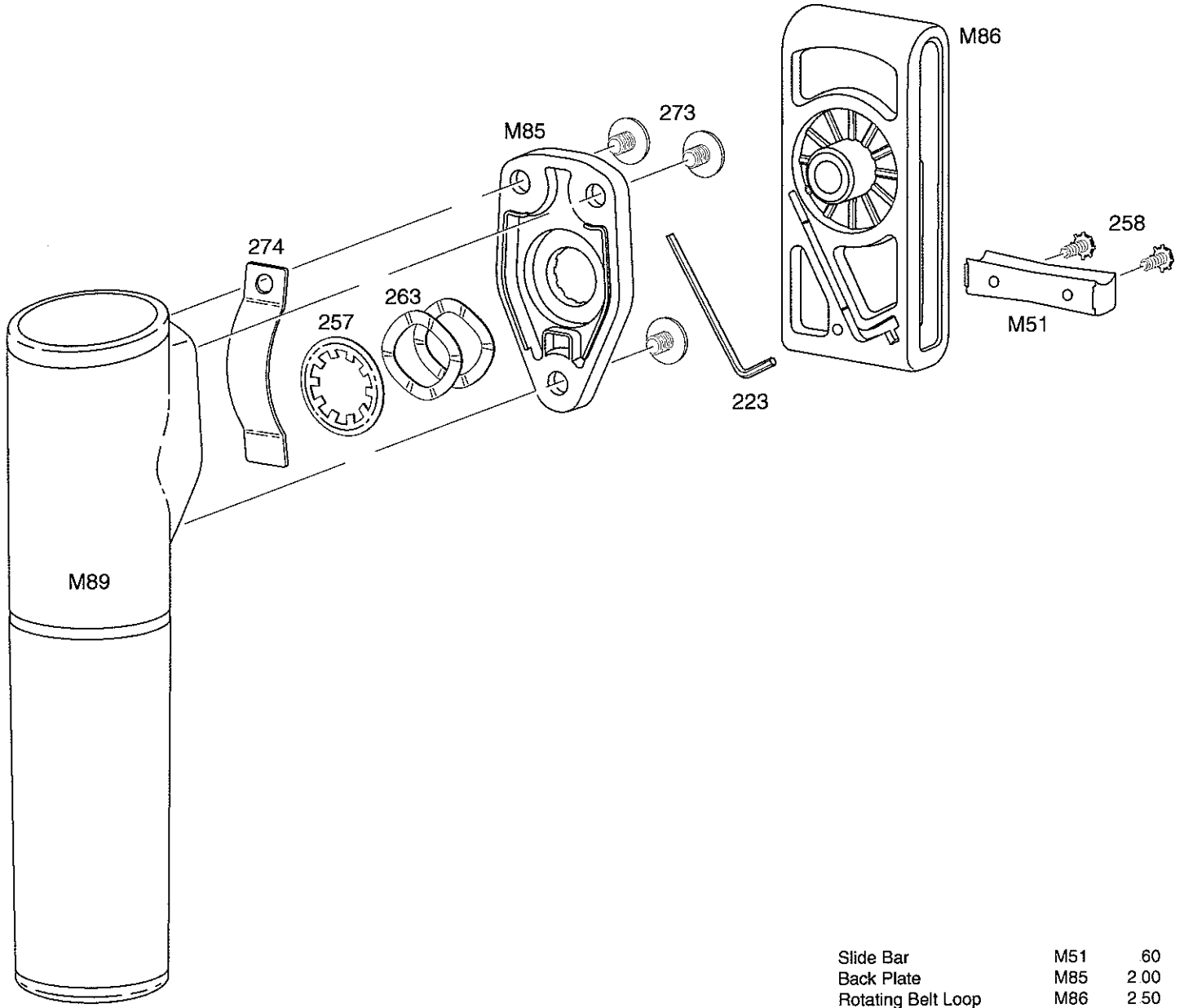
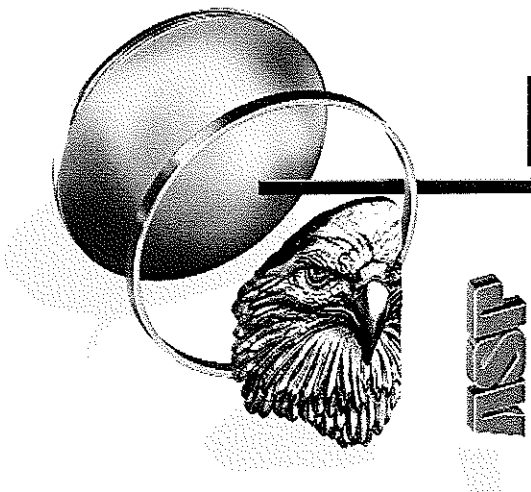

Slide Bar	M51	.60
Back Plate	M85	2.00
Rotating Belt Loop	M86	2.50
Body, Black	M89	6.30
Hex Key	223	.25
Lock Ring	257	.20
Slide Bar Screw	258	.25
Wave Washer	263	.25
Adjustment Screw	273	.75
Retention Clip	274	.20

DATABASE

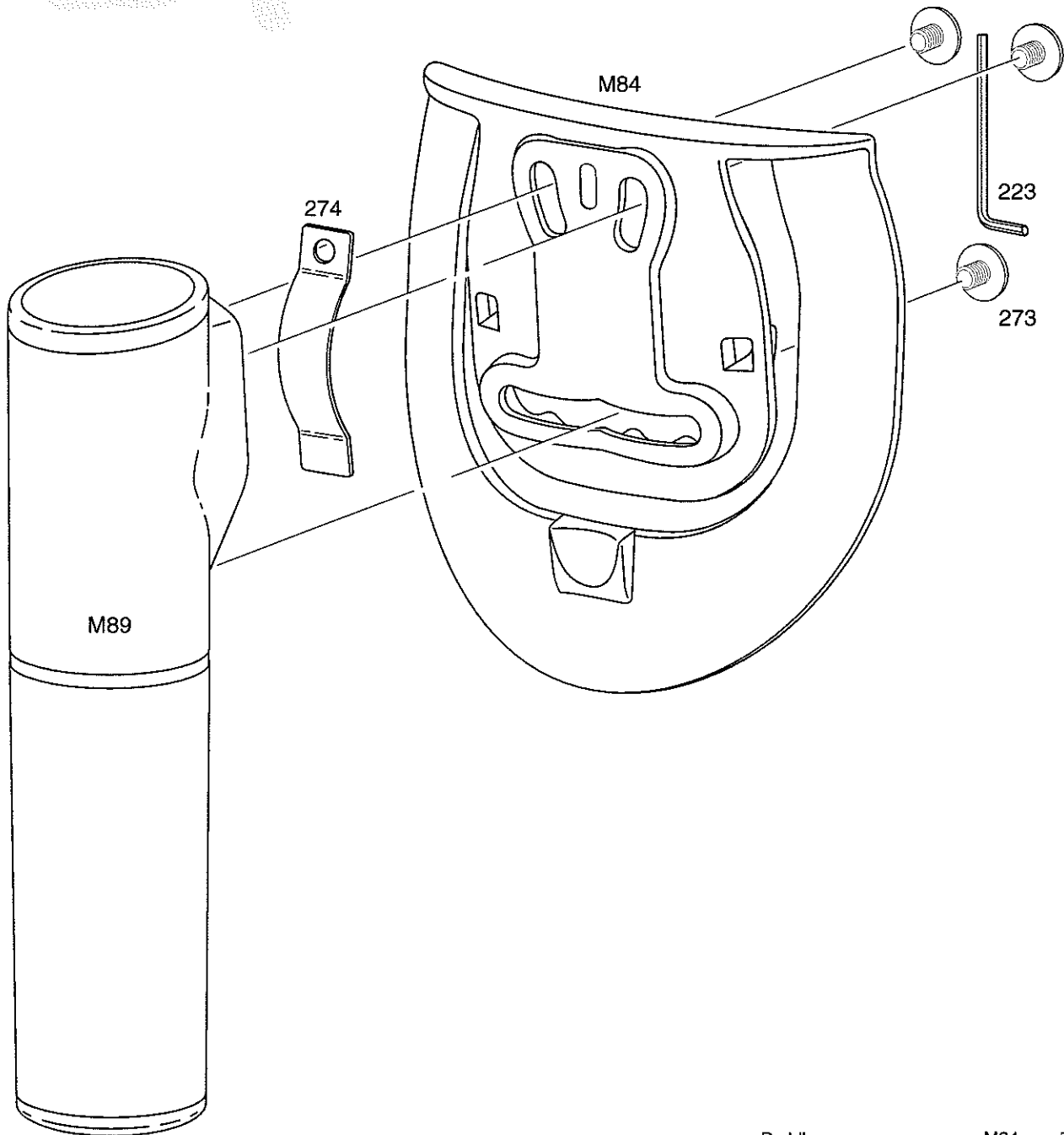
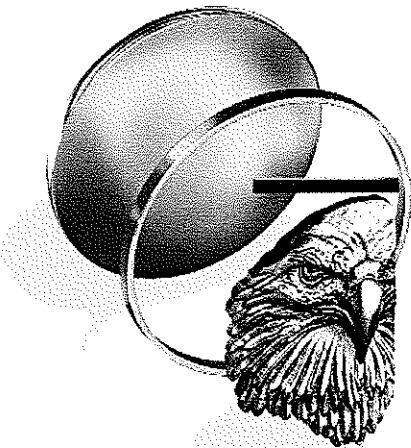

Paddle	M84	5.00
Body, Black	M89	6.30
Hex Key	223	.25
Adjustment Screw	273	.75
Retention Clip	274	.20

Palm Defender OC DATABASE

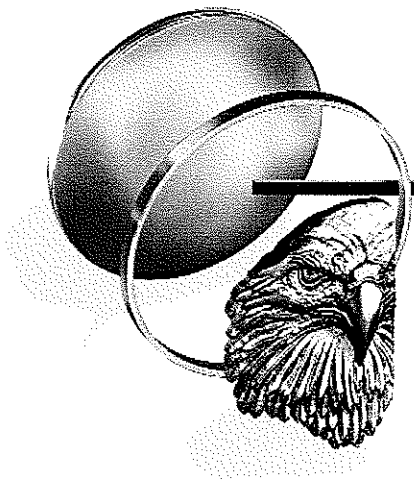

MSR

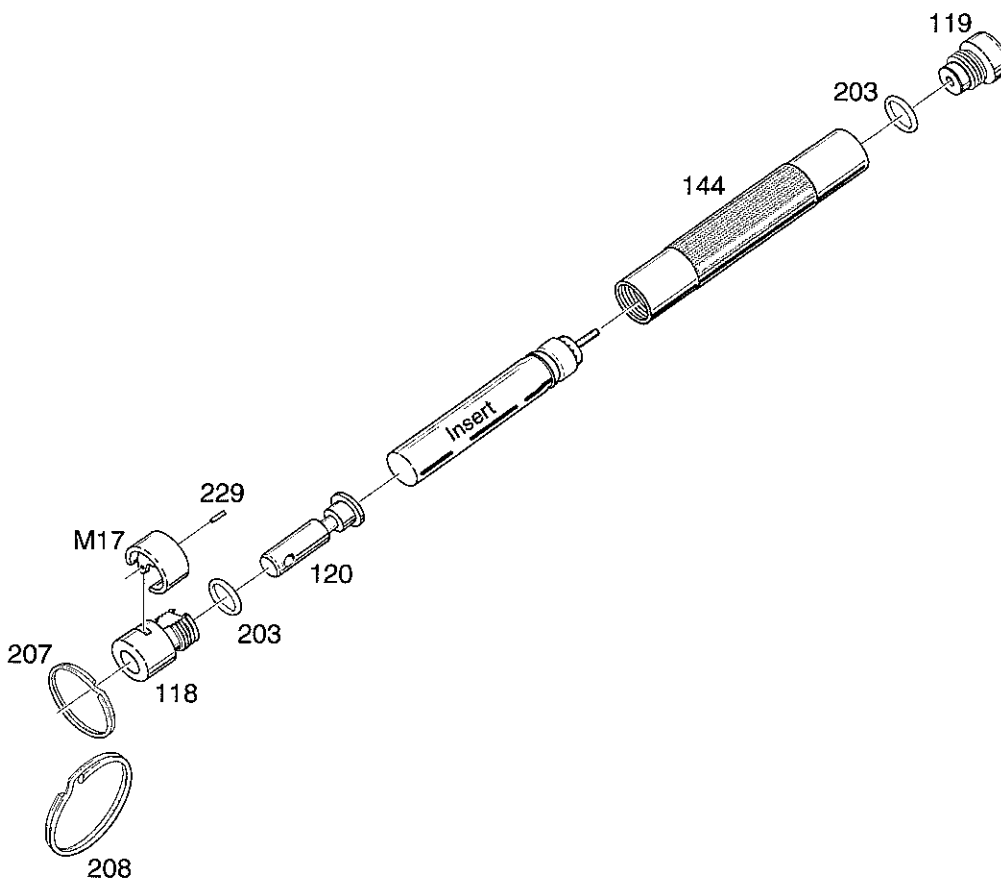

Body*	144	5.00	Swivel	120	1.50
Electroless	144E	7.50	Dowel Pin	229	10
18K Gold	144G	11.25	Safety Lock	M17	25
Textured	144T	7.50	Plug End O-Ring	203	05
Cap*	118	5.00	Tip End O-Ring	203	05
Electroless	118E	6.25	Small Split Ring	207	40
18K Gold	118G	8.75	Large Split Ring	208	50
Textured	118T	6.25			
Tip*	119	2.50			
Electroless	119E	3.75			
18K Gold	119G	6.25			
Textured	119T	3.75			

* For the Body (144), Cap (118), Tip (119), specify:
Blue Violet Pewter, Red, Black or Gold

Key Defender OC DATABASE

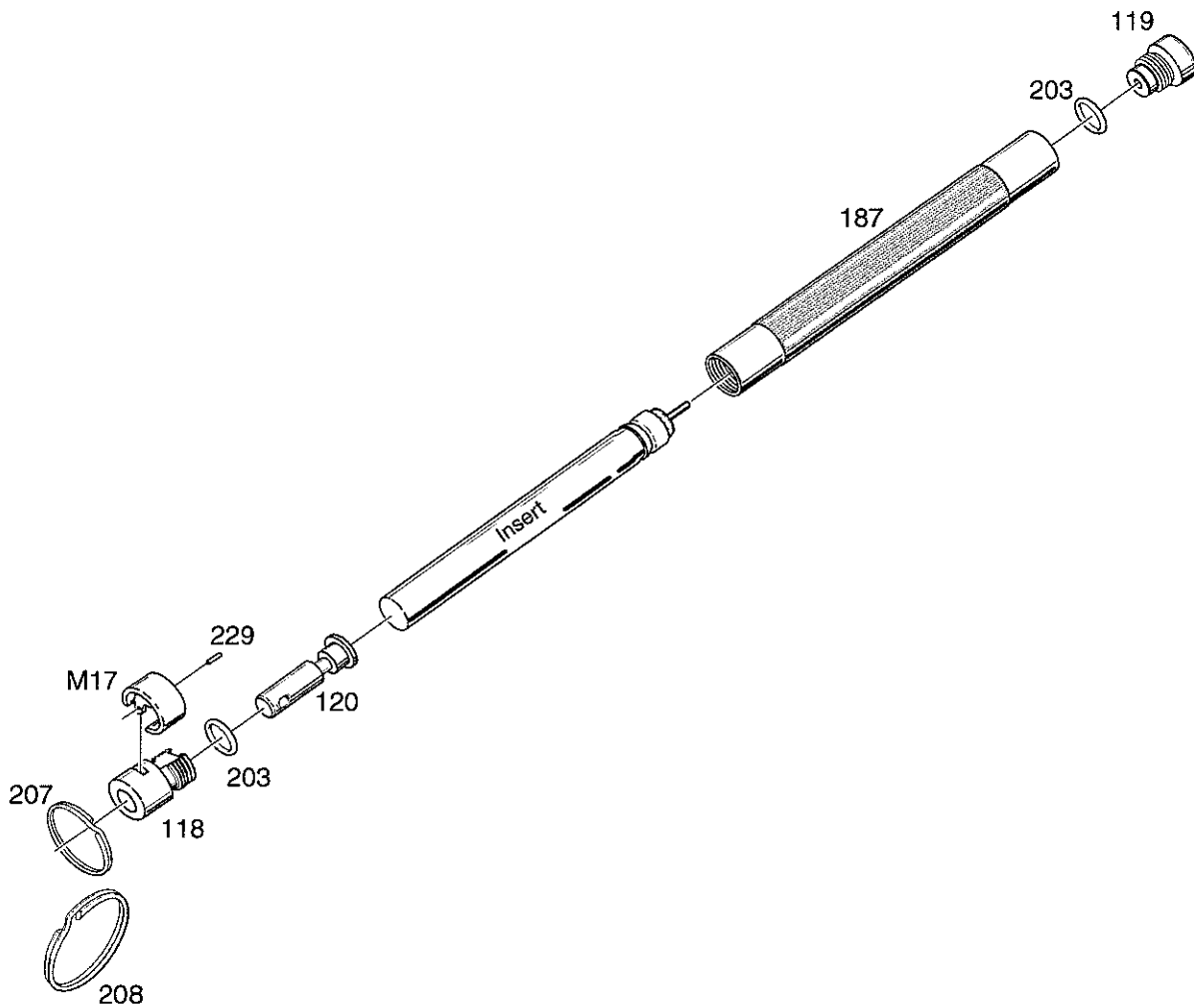
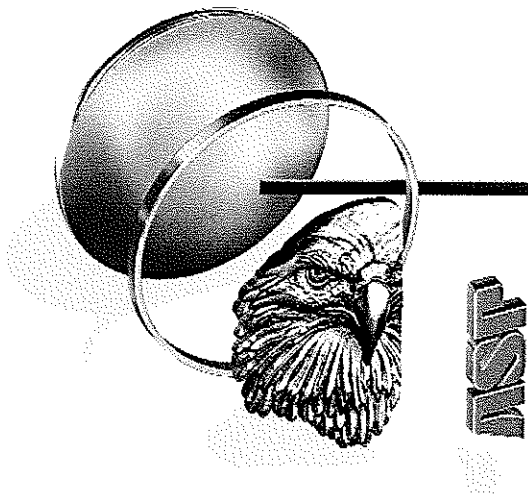

Body*	187	5.75	Swivel	120	1.50
Electroless	187E	8.75	Dowel Pin	229	.10
18K Gold	187G	12.50	Safety Lock	M17	.25
Textured	187T	8.75	Plug End O-Ring	203	.05
Cap*	118	5.00	Tip End O-Ring	203	.05
Electroless	118E	6.25	Small Split Ring	207	.40
18K Gold	118G	8.75	Large Split Ring	208	.50
Textured	118T	6.25			
Tip*	119	2.50			
Electroless	119E	3.75			
18K Gold	119G	6.25			
Textured	119T	3.75			

* For the Body (187), Cap (118), Tip (119), specify:
Blue, Violet, Pewter, Red, Black or Gold

Street Defender OC DATABASE

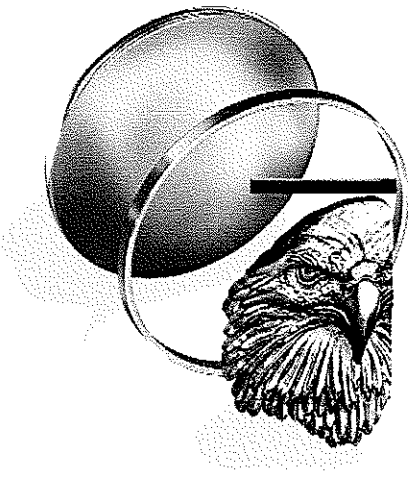

USA

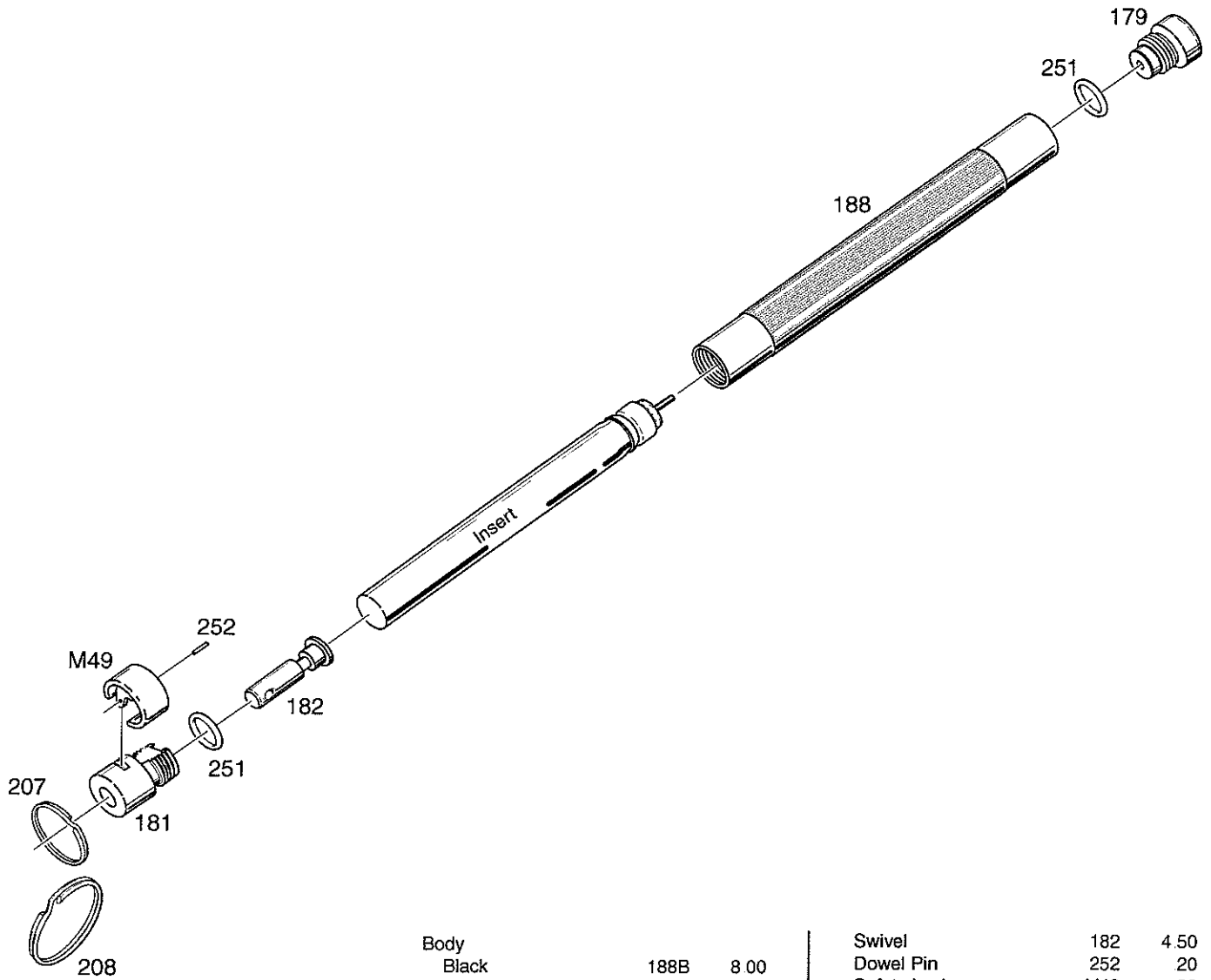

Body			
Black	188B	8 00	
Electroless	188E	9 50	
Textured	188T	10 25	
Cap			
Black	181B	6 25	
Electroless	181E	7 50	
Textured	181T	8 25	
Tip			
Black	179B	4 75	
Electroless	179E	6 25	
Textured	179T	7 00	

Swivel	182	4 50
Dowel Pin	252	20
Safety Lock	M49	30
Plug End O-Ring	251	10
Tip End O-Ring	251	10
Small Split Ring	207	40
Large Split Ring	208	50

Tactical Defender OC DATABASE

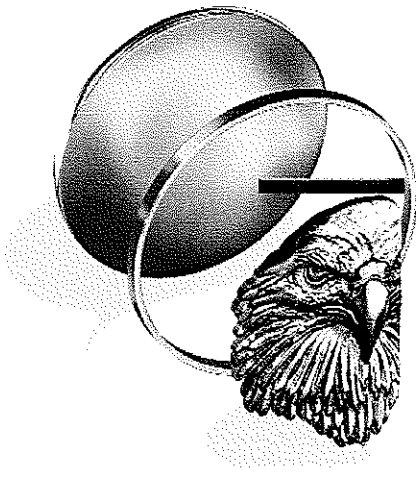

MSD

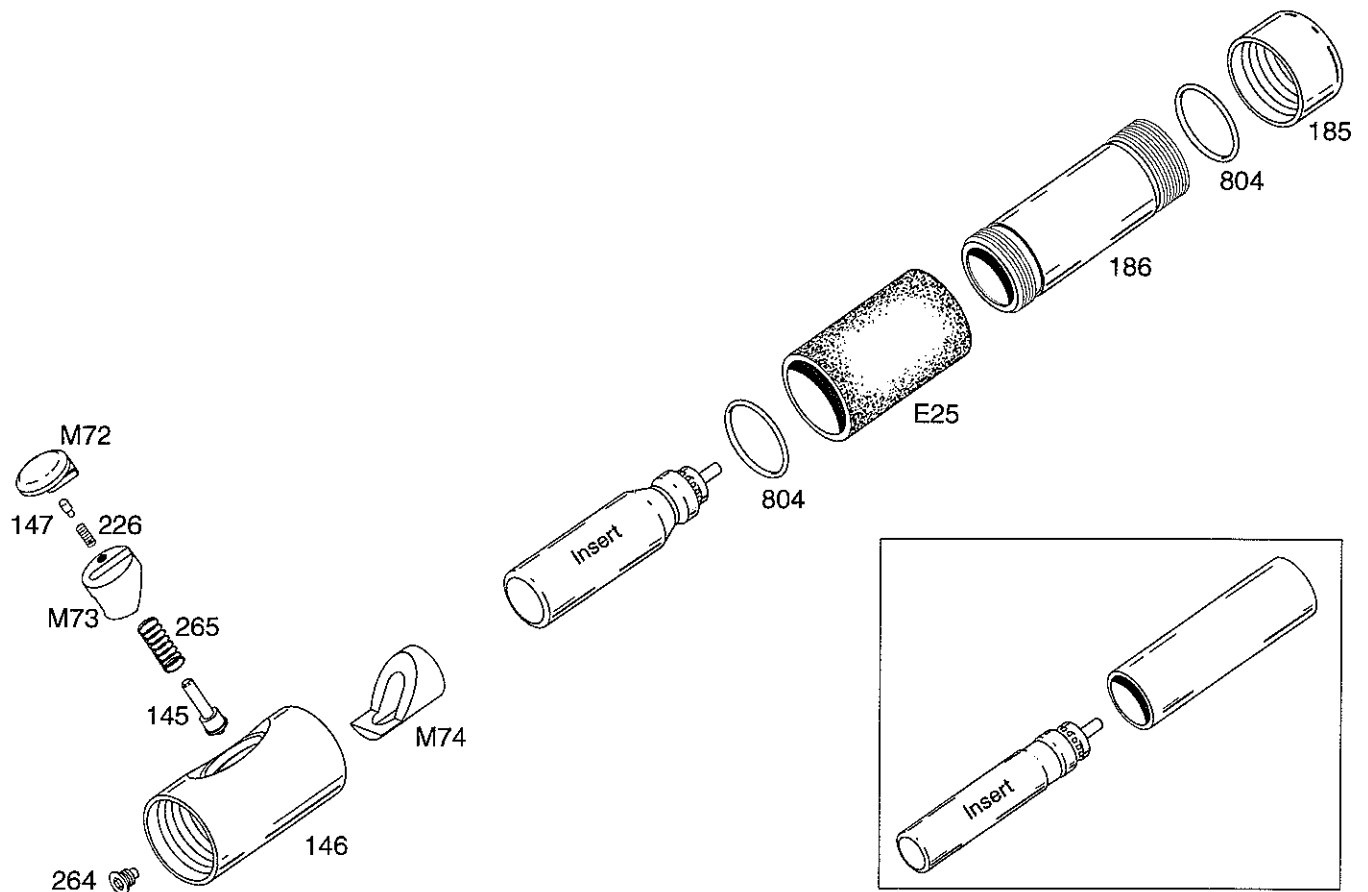

O-Ring, Canister Tube	804	10
Grip, Tactical Defender	E25	2.00
Canister Tube	186	18.05
Canister Head	185	10.00
Housing Actuator, Black	146	18.00
Pin, Actuator	145	2.50
Plunger, Safety	147	2.50

Screw	264	1.25
Spring, Button	265	.50
Spring, Plunger	226	.50
Button, Safety	M72	2.50
Button Actuator	M73	5.00
Plunger, Actuator	M74	7.50

26 Training Baton DATABASE

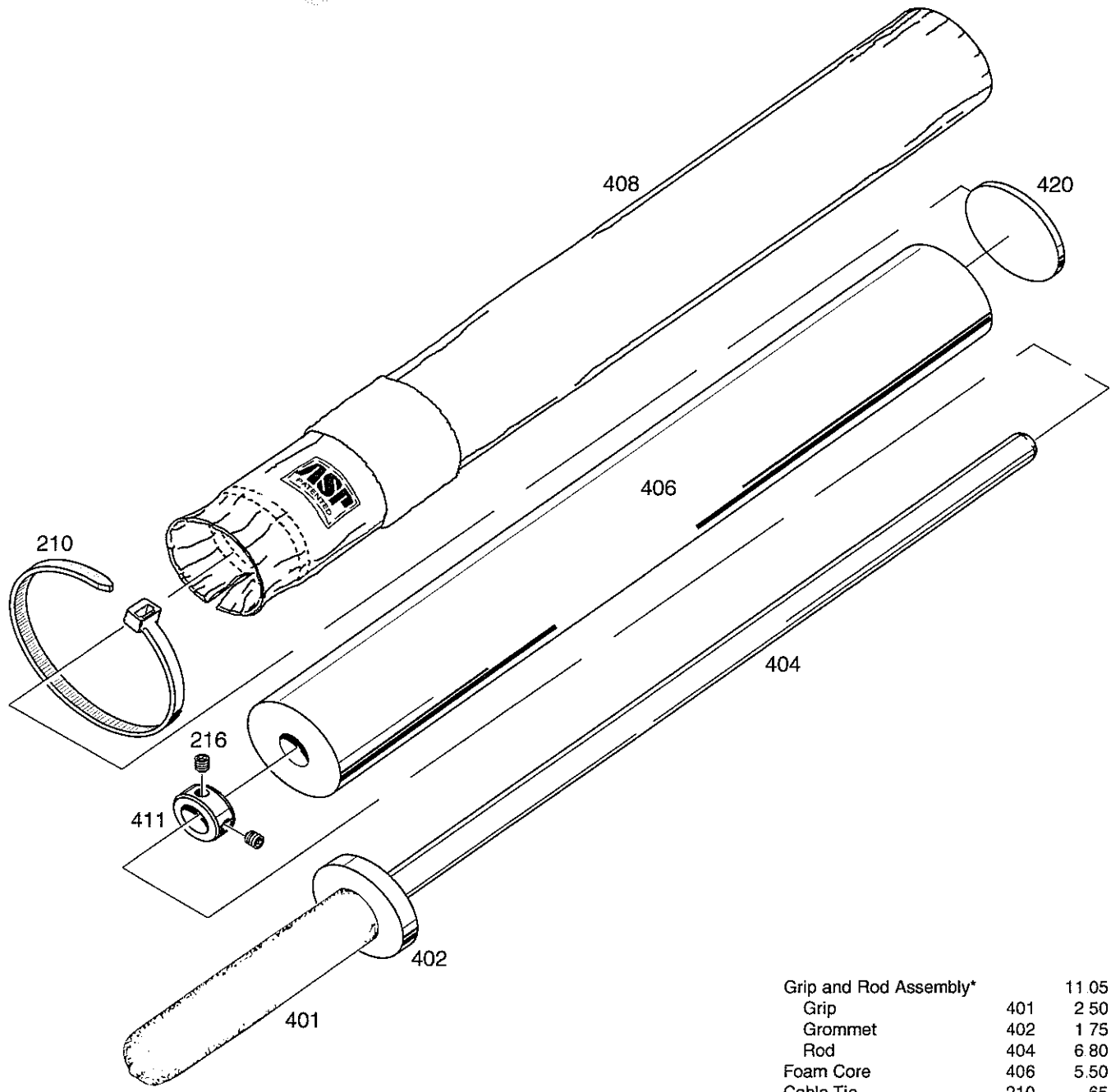
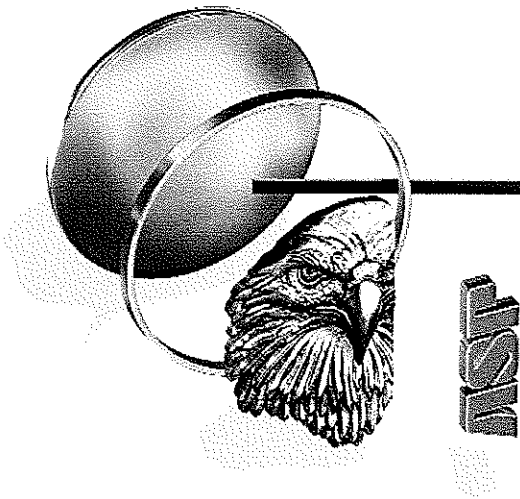

Grip and Rod Assembly*		11.05
Grip	401	2.50
Grommet	402	1.75
Rod	404	6.80
Foam Core	406	5.50
Cable Tie	210	.65
Cover	408	14.20
Locking Collar	411	2.50
Set Screw	216	.50
Tip Disk	420	.55

* Grip and Rod Assembly consists of Part Numbers 401 402 and 404.

Triad Elite DATABASE

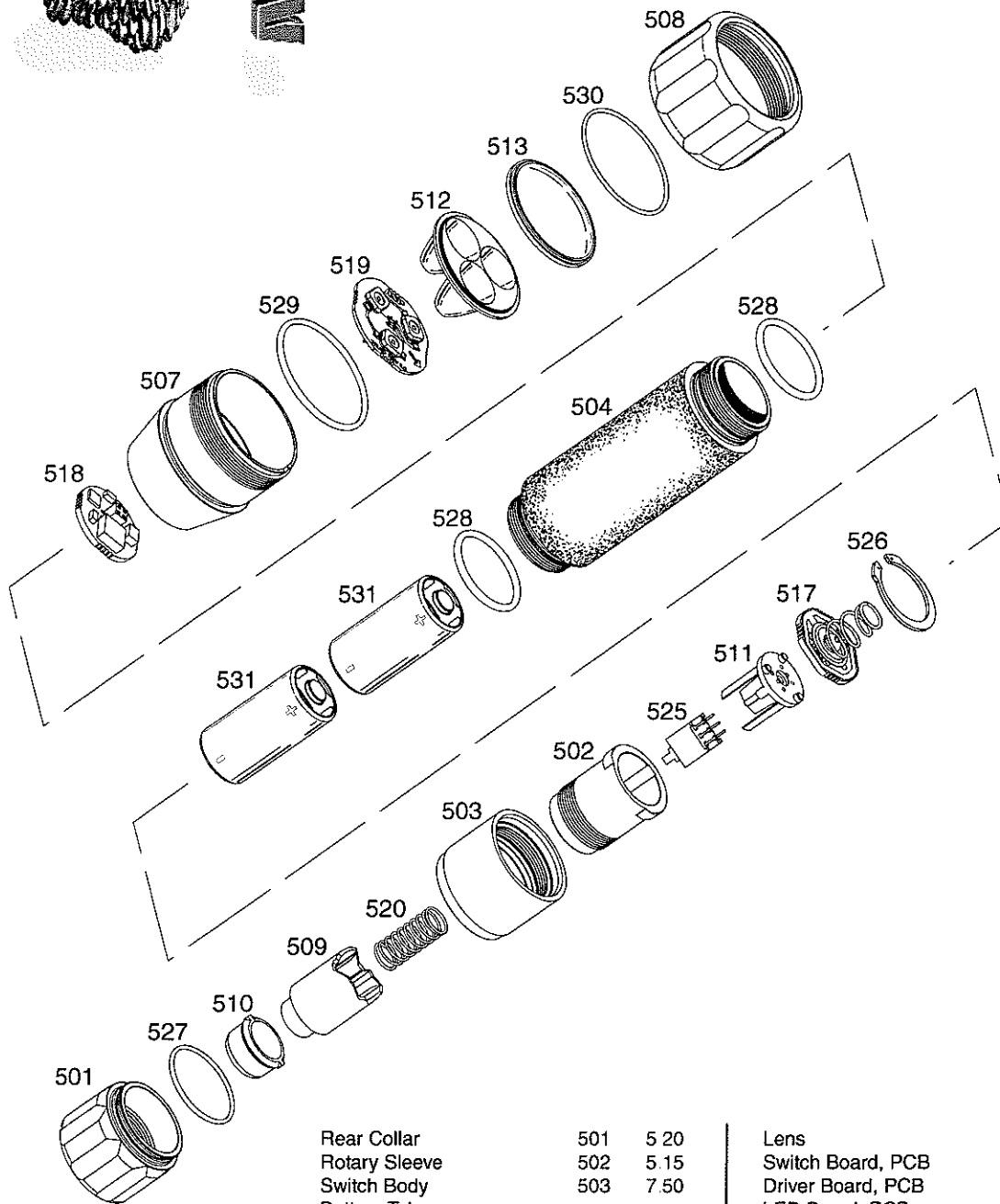
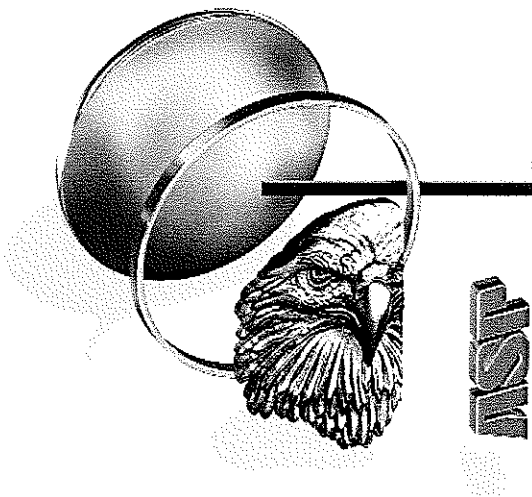

Rear Collar	501	5 20	Lens	513	1 00
Rotary Sleeve	502	5 15	Switch Board, PCB	517	6 00
Switch Body	503	7 50	Driver Board, PCB	518	30 00
Battery Tube			LED Board, PCB	519	70 00
2 Cell	504	6 25	Switch Spring	520	1 00
3 Cell	505	10 00	Switch	525	2 00
Powerhead	507	13 50	Internal Snap Ring	526	.50
Front Collar	508	5 20	O-Ring, Switch	527	.25
Button	509	2 00	O-Ring, Battery Tube	528	.25
Overmolded Button	510	1 00	O-Ring, Powerhead	529	.30
Cam Plate	511	1 25	O-Ring, Lens	530	.50
Reflector	512	5 00	Batteries, Lithium 3 Volt	531	1 75 each



Box 1794 · Appleton, WI 54912 (920) 735-6242 · Fax (920) 735-6245 · asp-usa.com

Tactical Handcuffs

TECHNICAL SPECIFICATIONS

	100/150	200/250	300/350
Format	Chain Cuff	Hinge Cuff	Rigid Cuff
Frame Material	Stainless Steel	Stainless Steel	Stainless Steel
Frame Design	Interlocking Folded Sheet	Interlocking Folded Sheet	Interlocking Folded Sheet
Frame Structure	Hardened	Hardened	Hardened
Rigidity	Tapered Ribs	Tapered Ribs	Tapered Ribs
Overmold Material	Polymer	Polymer	Polymer
Colors	Black	Black	Black
Identifier (100, 200)	Blue, Brown, Gray Yellow, Orange, Pink	Blue, Brown, Gray Yellow, Orange, Pink	
Overmold Finish	Textured	Textured	Textured
Edges	.035 Minimum Radius	.035 Minimum Radius	.035 Minimum Radius
Bow Material	[Model 100] High Carbon Steel [Model 150] 7075 T6 Aluminum	[Model 200] High Carbon Steel [Model 250] 7075 T6 Aluminum	[Model 300] High Carbon Steel [Model 350] 7075 T6 Aluminum
Steel Bow Finish	Satin Chrome	Satin Chrome	Satin Chrome
Aluminum Bow Finish	Matte Black	Matte Black	Matte Black
Bow Guides	Pierced Arc	Pierced Arc	Pierced Arc
Bow Locking Positions	22	22	22
Bow Teeth	Deep Set	Deep Set	Deep Set
Bow Face	Flat, High Contact	Flat, High Contact	Flat, High Contact
Bow Geometry	Conical	Conical	Conical
Bow Pivot	Stainless Bushing	Stainless Bushing	Stainless Bushing
Smallest Cuff Area	2.8 Square Inches	2.8 Square Inches	2.8 Square Inches
Largest Cuff Area	5.68 Square Inches	5.68 Square Inches	5.68 Square Inches
Cuff Range (Square Inches)	2.88	2.88	2.88
Weight (Steel Bow)	9.0 Ounces	10 Ounces	12.8 Ounces
Weight (Aluminum Bow)	7 Ounces	8.5 Ounces	10.7 Ounces
Overall Length	9.4 Inches	9.2 Inches	9.2 Inches

Chain Handcuff DATABASE

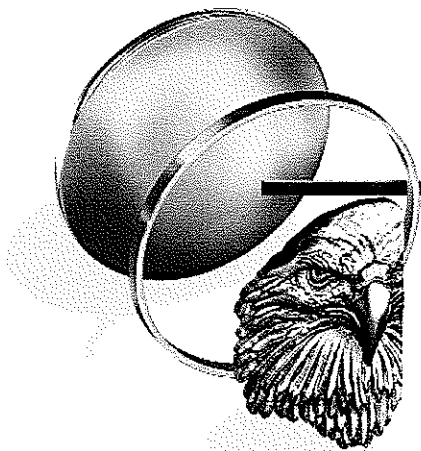

TSP

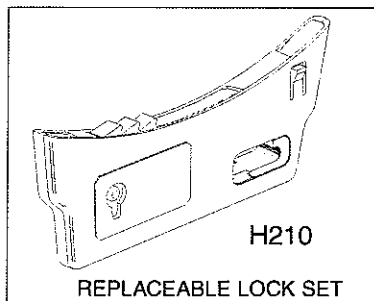
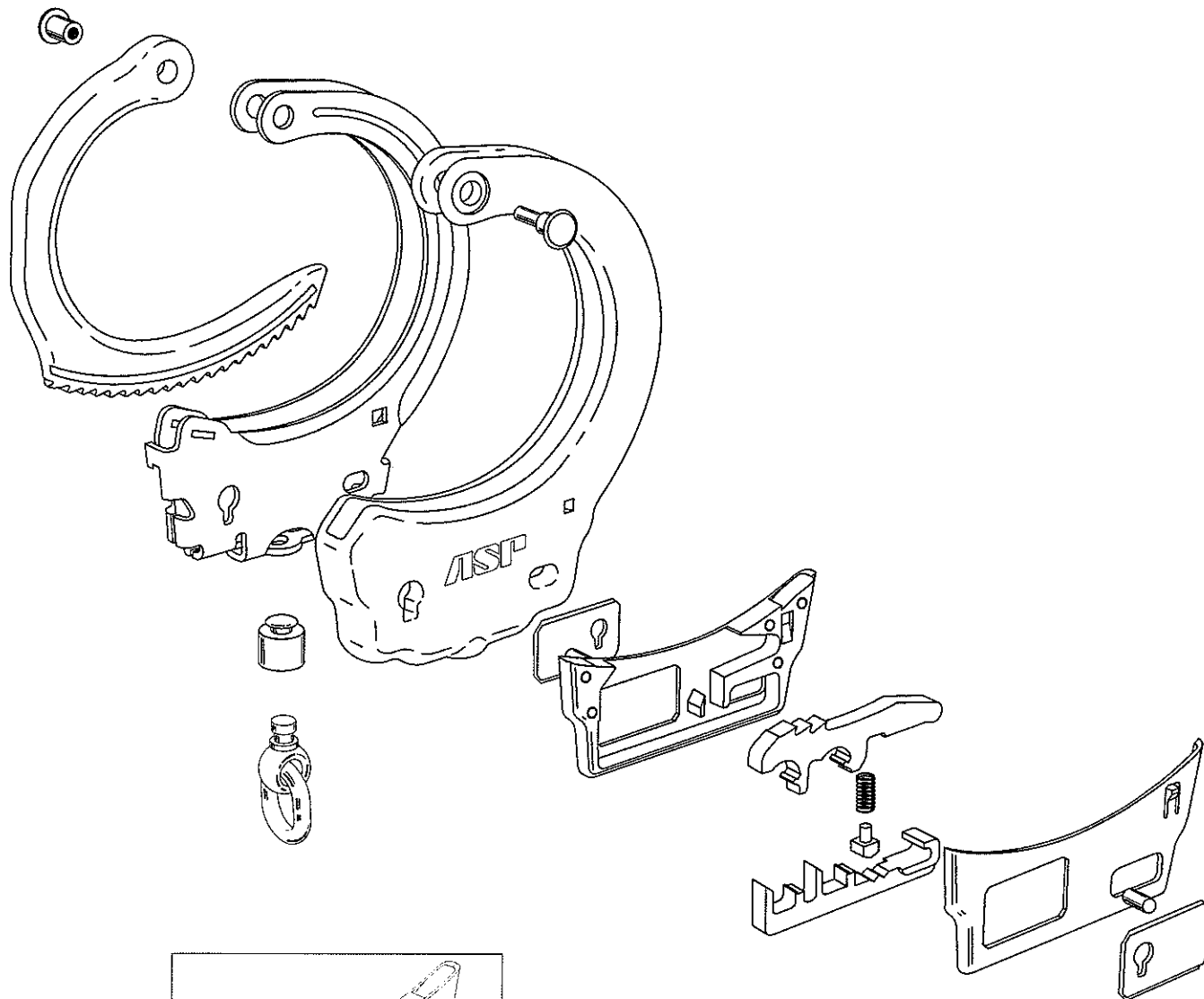

H210

REPLACEABLE LOCK SET

Lock Set

H210

6 25

Hinge Handcuff DATABASE

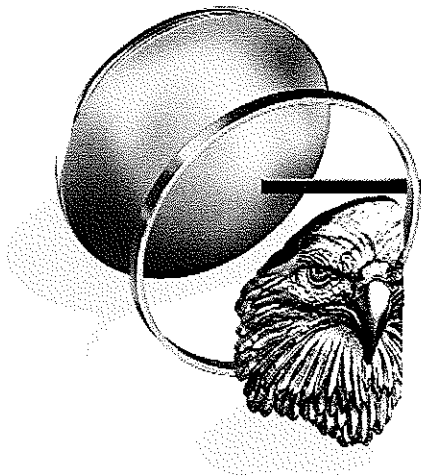

ASP

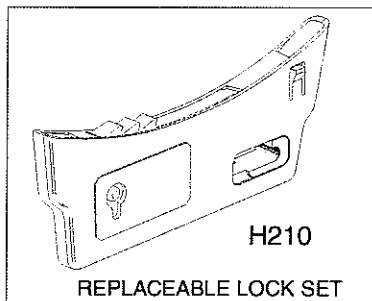
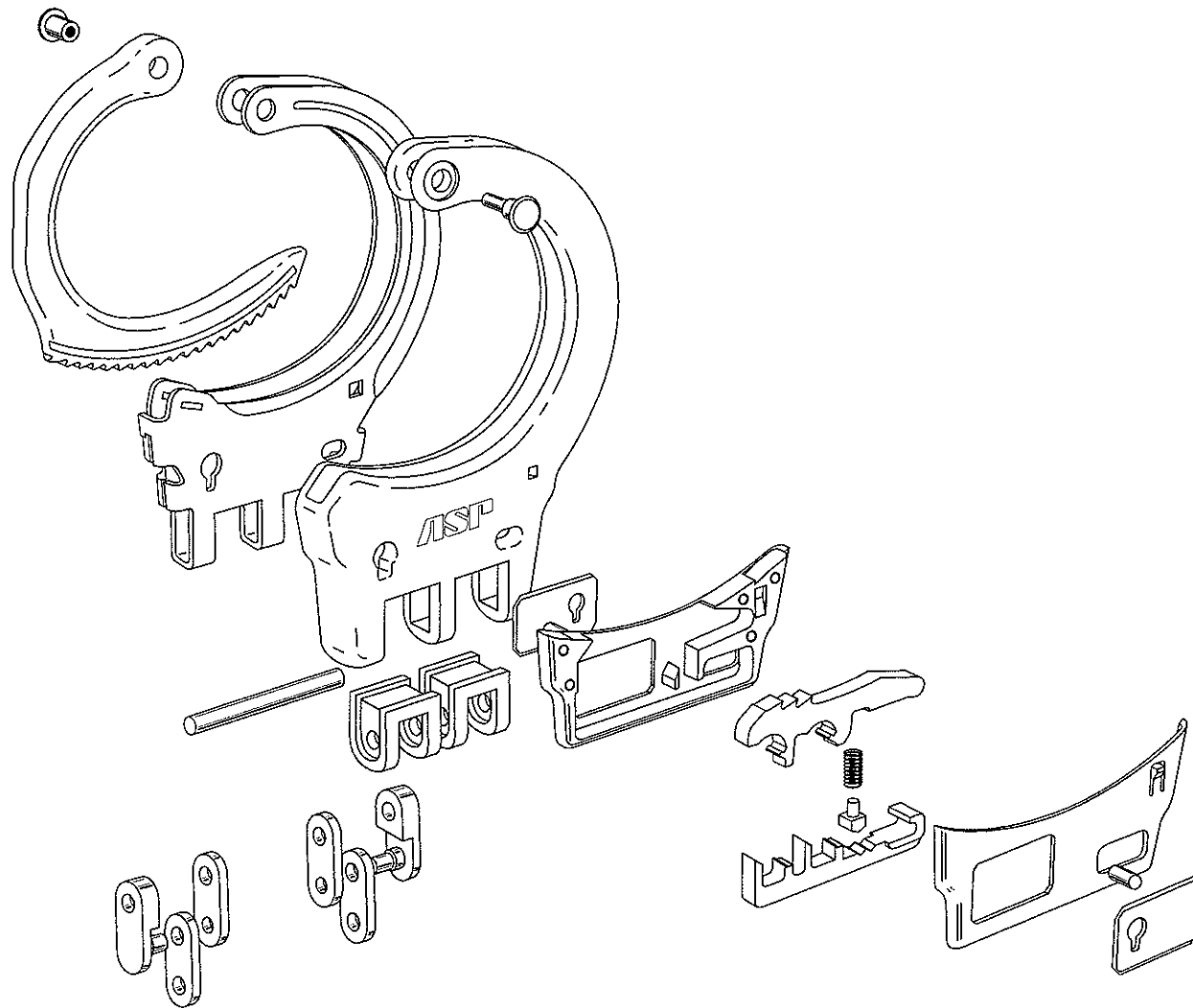

Lock Set

H210

6.25

Rigid Handcuff DATABASE

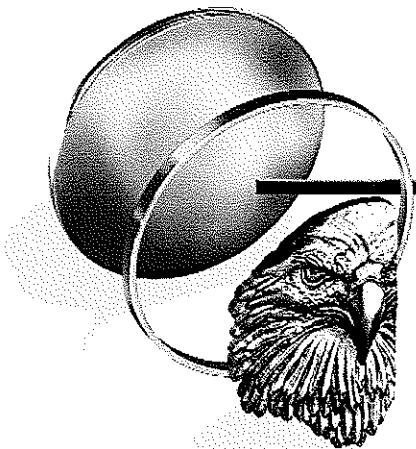

ASP

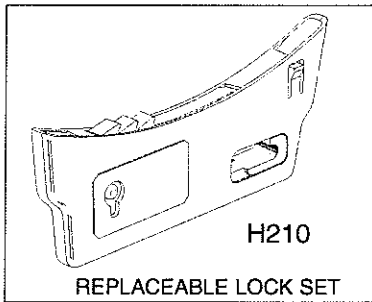
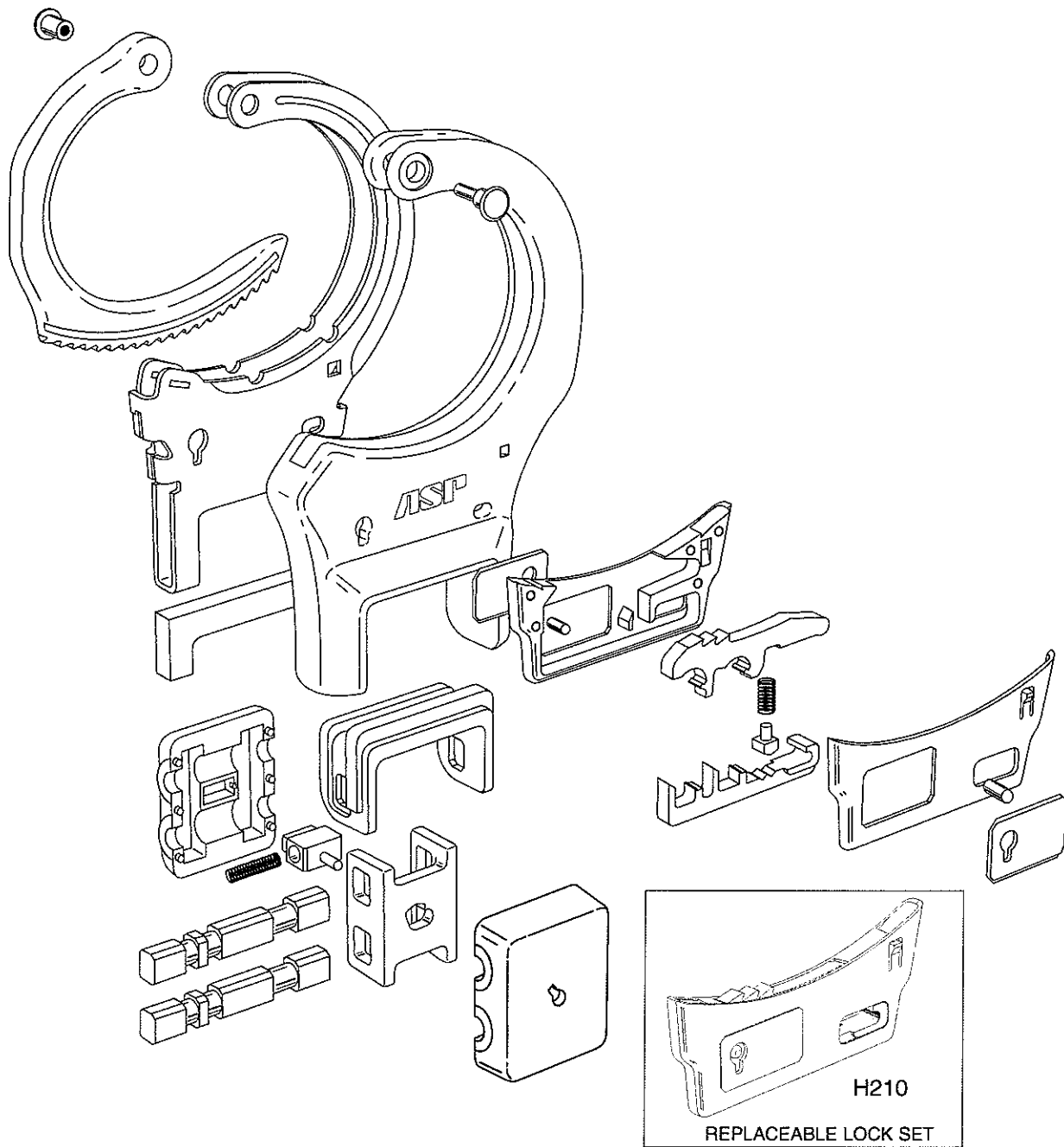

H210

REPLACEABLE LOCK SET

Lock Set

H210

6 25

Professional Vita and Client References

POLICE USE OF FORCE

Kevin Parsons, PhD
KEVIN PARSONS AND ASSOCIATES, INC
Box 356
Appleton, WI 54912

Phone (920) 735-6240
Fax (920) 735-6245

January 1998

KEVIN PARSONS, PhD

Kevin Parsons is a frequent lecturer on force issues for national organizations including the American Bar Association and the AELE Law Enforcement Legal Defense Institute. A force consultant, he has designed programs and conducted training for major agencies including the Federal Bureau of Investigation, US Drug Enforcement Administration, Royal Canadian Mounted Police and United States Secret Service. His firm trains in excess of forty law enforcement agencies per month. At the present time, DR Parsons is working on Use of Force training programs for the Swedish Secret Service and the 40,000-member Police Federation of Britain and Wales. He holds ten United States Patents on Law Enforcement Weapon Designs including side handle and expandable batons, holsters and training devices.

Frequently called as an expert witness in major police misconduct litigation, Kevin Parsons has testified over 500 times in 43 states. His twenty-seven member firm is located in Appleton, Wisconsin.



KEVIN PARSONS and ASSOCIATES, INC

Box 356 Appleton, WI 54912 · (920) 735-6240 Fax (920) 735-6245

PROFESSIONAL VITA

PERSONAL DATA

Name: Kevin Parsons

Office Address: 2511 E Capitol Drive
Appleton, WI 54911

Telephone: Office (920) 735-6240
Fax (920) 735-6245
Home (920) 731-9282

Date of Birth: 16 January 1950

Family Status: Married
Two Daughters

EDUCATION

BA University of Northern Iowa
(Honors Graduate - Communication)
1972

MA University of Nebraska - Omaha
(Criminal Justice Administration)
1976

PhD School of Criminal Justice
Michigan State University
1981

Areas of Specialization:
Police Administration
Policy Development
Training System Design

PRESENT OCCUPATION

Use of Force consultant specializing in policy formation, training system design and performance evaluation of federal, state and municipal agencies.

EXPERT WITNESS EXPERIENCE

Analyst and witness in both State and United States District Courts.

Analyst and witness in both Civil and Criminal cases.

Analyst and witness in Use of Force, Protection from Force and Force Technology cases.

Analysis of techniques, tactics, procedures, training and policy as they relate to established standards of professional conduct.

Testimony in excess of 500 times regarding all major categories of force litigation. (Dialog, control procedures, hands and feet, impact weapons, flashlight, electrical weapons, tactical team procedures, chemical agents, neck restraints, firearms, handcuffs)

CONSULTING EXPERIENCE

Selected Training Contracts

1979	Police Training Institute University of Illinois Champaign, Illinois Evaluation of Training System
1980-1989	Hillsborough County Sheriff's Department Tampa, Florida Baton Instructor Training System
1981	International Association of Chiefs of Police Denver, Colorado Managing Police Training Programs
1982	Southwest Louisiana Police Training Institute Mechanics of Arrest and Impact Weapons Training
1982	United States Secret Service Use of Force Policy Board
1982-1986	State of Wisconsin Bureau of Police Standards and Training Subject Control Training System Design (Five Contracts)
1982-1984	Milwaukee Police Department Subject Control and Mechanics of Arrest Training System Design (Two Contracts)
1983-1986	State of Wisconsin Bureau of Police Standards and Training Impact Weapons Training System Design (Five Contracts)

1983-1984	Milwaukee Police Department Impact Weapons Training System Design (Two Contracts)
1983	United States Secret Service Active Countermeasures Agency Wide Instructor Training
1984	Smith & Wesson Academy Use of Force Training System Design (Two Contracts)
1984	Office of the Inspector General Annual Supervisor Training Conference New Directions in Use of Force Training
1984-1989	Office of the Inspector General Washington, DC Subject Control Training System Design (Eight Contracts)
1984	Greater St. Louis Chiefs of Police Use of Force Liability Defense
1984	State of North Dakota Office of the Attorney General Use of Force Training System Design
1985	Federal Bureau of Investigation National Academy Vicarious Liability Defense Strategy
1985-1989	Hillsborough County Sheriff's Department Tampa, Florida Baton Instructor Training System (Three Contracts)
1985	Illinois Institute for Continuing Legal Education Chicago, Illinois Use of Force by Security Personnel
1985-1986	Institute of Police Technology and Management Jacksonville, Florida Use of Force Training System Design (Two Contracts)
1986-Date	Governmental Programs Police Policies and Procedures Advisory Council (Semi-Annual Meetings)
1986	Wisconsin Association of SWAT Personnel Subject Control During SWAT Operations
1986	Arizona Department of Public Safety Liability Assessment

1986	American Bar Association National Institute of Transportation Facility Negligence Terrorism and the Use of Force
1986-1988	International Association of Chiefs of Police The Investigation of Shootings by Police Officers 1986 (2), 1987, 1988
1986-1989	Hillsborough County Sheriff's Department Tampa, Florida Subject Control Instructor Training System (Four Contracts)
1986-1989	Hillsborough County Sheriff's Department Tampa, Florida Tactical Control Instructor Training System (Two Contracts)
1986-Date	AELE Law Enforcement Legal Defense Center Police Civil Liability Workshop Analysis of Use of Force Litigation 1986 (2), 1987 (2), 1988 (3), 1989, 1990, 1991, 1992, 1993, 1994 (2)
1986	Annual Conference of State Police Training Academy Directors Issues in the Use of Force
1986-Date	National Law Enforcement Explorers Conference Use of Force Issues and Procedures (1986, 1988, 1990, 1992)
1986-1987	AELE Law Enforcement Legal Defense Center Issues Involving Use of Expert Witnesses in Police Misconduct Litigation (Two Contracts)
1986-1988	Institute of Police Technology and Management Strategies for Defense of Police Use of Force Liability Suits (Three Contracts)
1987	United States Drug Enforcement Administration Tactical Baton Use in High Risk Incidents
1987	Midwest Association of Legal Investigators Analysis of Use of Force Litigation (Two Contracts)
1987	Institute of Police Technology and Management Tactical Control for Drug Enforcement Officers
1987	International Association of Chiefs of Police Developing Policies and Procedures
1987	International Association of Chiefs of Police Police Firearm Instructor Certification School

1987-1988	International Association of Chiefs of Police Workshop for Newly Appointed Chiefs of Police (Three Contracts)
1987	Tampa Police Department Subject Control Instructor Training System
1987	Tampa Police Department Baton Instructor Training System
1987	Florida Association of Police Attorneys Analysis of Use of Force Incidents
1987	Albuquerque Police Department Recruit Class Implications of Use of Force on the Street
1987	Internal Revenue Service Criminal Investigation Division Annual Training Conference The Need for Intermediate Force Training
1987	National Association of Legal Investigators Educational Seminar for Legal Investigators
1988	Florida Law Enforcement Trainers Design of Use of Force Training Systems
1988-1990	AELE Law Enforcement Legal Defense Center Developing Police Policies and Procedures 1988, 1989 (2), 1990
1988	United States Drug Enforcement Administration Use of Force Issues for Drug Team Commanders
1988	United States Coast Guard - Maritime Law Enforcement Command/West Coast Use of Force Instructor Certification
1988	Iowa Association of Police Trainers Designing Use of Force Training Systems
1988	Wisconsin Court Reporters The Expert Witness During Deposition
1988	United States Coast Guard - Maritime Law Enforcement Command/East Coast Use of Force Instructor Certification (Two Contracts)
1988	Anchorage Police Department Supervision and Discipline of Use of Force Incidents
1988	FBI - Atlanta SWAT Team Use of Force Training

1988	Albuquerque Police Department RISC Management Training System Design
1988-1989	Northwest Illinois Police Academy Development of Use of Force Policies and Procedures (Two Contracts)
1989	Kent County (MI) Sheriff's Department Supervising and Discipline of Use of Force Incidents
1989	Kent County (MI) Sheriff's Department Subject Control Instructor Certification
1989	Kent County (MI) Sheriff's Department Baton Instructor Certification
1989	Northeast (IL) Multi Regional Training Academy Investigating Use of Force Incidents
1989	Institute of Police Technology and Management Baton Instructor Certification
1990	AELE Law Enforcement Legal Defense Center Private Security Legal Issues
1990	San Bernardino County (CA) Sheriff's Department Use of Force Training Systems
1990	New Hampshire Municipal Association Use of Force Policy, Training and Supervision
1990	US Drug Enforcement Association Impact Weapon Instructor Certification
1990	US State Department Impact Weapon Instructor Certification
1990	Royal Canadian Mounted Police British Columbia, Canada Impact Weapon Instructor Certification
1990	Baton Instructor Trainer Certification International Conference
1990-1991	Texas Municipal League Risk Management in Law Enforcement (Two Contracts)
1991	Illinois Institute for Continuing Legal Education Section 1983 Civil Rights Liability & Litigation Annual Conference
1991	Toronto, Canada Police Department Impact Weapon Instructor Certification

1991	FBI - Southern California Impact Weapon Instructor Certification
1991	Minnesota Training Officers Association Designing Use of Force Training Programs
1991	Canadian Military Police Impact Weapon Instructor Certification
1992	Baton Instructor Trainer Certification International Conference
1992	Scottsdale Insurance Company Evaluating Use of Force Incidents
1992	State of Alaska Advanced Criminal Investigation Training Investigating Use of Force Incidents
1992	Avon and Somerset, England Constabulary Impact Weapon Instructor Certification
1992	Police Federation of Britain and Wales Reducing Assaults Upon Law Enforcement Personnel
1992	FBI/DEA Baton Instructor Certification
1992	Peoria (IL) Police Department Supervision and Discipline of Use of Force Incidents
1992-Date	American Bar Association Section 1983 Civil Rights Liability and Litigation 1992 (2), 1993 (2), 1994 (2)
1992-1993	SEAK Expert Witness Conference The Role of Expert Witnesses in the 1990's (Two Contracts)
1993	Cleveland Mayor's Task Force on Excessive Force Special Consultant
1993	Swedish Secret Service Instructor Training
1993	Baton Instructor Trainer Certification International Conference
1993	Use of Force Standards Illinois Municipal League Risk Management Association
1994	Butler & Binion Law Firm (TX) Managing Complex Litigation

1994	Georgia Association of Defensive Tactics Instructors Designing Use of Force Training Systems
1994	Sioux Falls (SD) Police Department RISC Management
1994	Baton Instructor Trainer Certification International Conference
1994	Mineral CO Sheriff's Office (WV) Use of Force By Police in the 90's

PROFESSIONAL EXPERIENCE

Instructor	Firearms and Defensive Tactics; Area VII, State of Iowa (1969-1975)		
Director	Justice System Training Association National Training Seminar for Police Firearms, Defensive Tactics and Physical Training Instructors		
	Miami Beach, Florida	Americana Hotel	1975
	Cincinnati, Ohio	Convention Center	1976
	Pittsburgh, Pennsylvania	Marriott Hotel	1977
	Cincinnati, Ohio	Netherland Hilton	1978
	New Orleans, Louisiana	Marriott Hotel	1979
	Washington, DC	Marriott Hotel	1980
	New Orleans, Louisiana	Hyatt Regency	1981
	Chicago, Illinois	Hyatt Regency	1982
	Kansas City, Missouri	Hyatt Regency	1983
	Indianapolis, Indiana	Radisson Plaza	1984
	New Orleans, Louisiana	Hyatt Regency	1985
	Milwaukee, Wisconsin	Red Carpet Hotel	1986
	Orlando, Florida	Orlando Marriott	1987
	Washington, DC	Fairfax Holiday Inn	1988
	Tampa, FL	Harbor Island	1989
Consultant	Design, Implementation and Monitoring of Use of Force Training Systems (1980-Date)		

PATENTS

Telescoping Self-Defense Keychain	4,752,072	21 JUN 88
Baton Clip	4,953,769	4 SEP 90
Baton Clip for Expandable Batons	4,955,518	11 SEP 90
Auxiliary Folding Handle	5,085,433	4 FEB 92
Baton: Method of Heat Treating Expandable	5,110,375	5 MAY 92

Locking Means for Extendable Baton	5,149,092	22 SEP 92
Button Lock (Canada)	2,067,030	12 APR 94
Retaining Clip for Expanding Baton	5,161,800	10 NOV 92
Baton Clip (Canada)	2,061,540	12 APR 94
Police Side Handle Baton	D333,692	2 MAR 93
Police Side Handle Training Baton	D333,693	2 MAR 93
BackPocket Expandable Scabbard	5,217,151	8 JUN 93
Alert Whistle	D344,037	8 FEB 94
Expandable Baton Apparatus	5,348,297	20 SEP 94
Airweight Baton	5,356,139	18 OCT 94
Search Mirror	5,386,322	31 JAN 95

PUBLICATIONS

Textbooks

TECHNIQUES OF VIGILANCE: A TEXTBOOK FOR POLICE SELF DEFENSE, Charles C. Thomas Publisher (1980)

Use and Abuse of the Expert Witness in Police Litigation in CIVIL RIGHTS LITIGATION AND ATTORNEY FEES ANNUAL HANDBOOK, National Lawyers' Guild, Clark Boardman Company, Volume 5 (1989)

Chapter 3: Security Requirements for Different Types of and Uses of Property
Chapter 7: Use of Force in SAFE PLACES? - SECURITY PLANNING AND LITIGATION
by Richard S. Kuhlman, The Michie Company (1989)

Decision to Use Force: The Confrontational Continuum in CIVIL RIGHTS LITIGATION AND ATTORNEY FEES ANNUAL HANDBOOK, National Lawyers' Guild, Clark Boardman Company, Volume 8 (1992)

Understanding the Weapons of Police Litigation in CIVIL RIGHTS LITIGATION AND ATTORNEY FEES ANNUAL HANDBOOK, National Lawyers' Guild, Clark Boardman Callaghan, Volume 10 (1995)

SCIENTIFIC PAPERS

- The Effect of a Simulation Model Upon the Comprehension and Retention of Dependent Performance Measures - Annual Meeting of the Midwest Association of Criminal Justice Educators (1978)
- Training v Education: A Decade of futile Debate - Annual Meeting of the Midwest Association of Criminal Justice Educators (1979)
- The Team Model: An Alternative Perspective - Annual Meeting of the Academy of Criminal Justice Sciences (1980)
- Criminal Justice Training System Design: A Decade in Perspective - Annual Meeting of the Academy of Criminal Justice Sciences (1980)
- Security Administration: Pseudo Science or Social Science Frontier - Annual Meeting of the Academy of Criminal Justice Sciences (1980)
- Psycho-Motor Skill System Design: Toward a Theory of Training in Criminal Justice - Annual Meeting of the Academy of Criminal Justice Sciences (1980)
- The Academic Consultant: A Review of Process, Potential and Pitfalls - Annual Meeting of the Academy of Criminal Justice Sciences (1980)
- Confrontational Stress: A Trainer's Perspective - 87th Annual Conference of the International Association of Chiefs of Police (1980)
- Organizational Theory: A Social Science Model for Undergraduate Criminal Justice Education - Annual Meeting of the Midwest Association of Criminal Justice Educators (1980)
- Confrontational Stress: Psycho-Biological Implications for Operational Agencies - Annual Meeting of the Academy of Criminal Justice Sciences (1980)
- Psycho-Motor Skill System Design: An Evaluation of the Yelon Model - Annual Meeting of the Academy of Criminal Justice Sciences (1981)
- Confrontational Stress: Psycho-Biological Implications for Operational Agencies - Annual Meeting of the American Society of Criminology (1981)
- Administrative Reorganization: The Implementation of Innovation in a Small Police Department - National Conference of the American Society of Public Administration (1982)
- Police Supervisory Skills: A Framework for Assessment - Annual Meeting of the Academy of Criminal Justice Sciences (1983)
- Current Issues in Law Enforcement Training - Annual Meeting of the Academy of Criminal Justice Sciences (1983)
- RISC Management: Designing Court Defensible Training Systems - 91st Annual Conference of the International Association of Chiefs of Police (1984)

TECHNICAL ARTICLES

- Female Performance in the Law Enforcement Function: A Review of Past Research, Current Issues, and Future Potential - LAW AND ORDER Magazine (January 1978)
- Proactive Weaponry Planning: A Systematic Police Formulation Model for Law Enforcement Agencies - LAW AND ORDER Magazine (January 1979)
- Is There a Place for the Martial Arts in 20th Century Law Enforcement - LAW AND ORDER Magazine (February 1979)
- Toward a Philosophy of Police Self Defense - LAW AND ORDER Magazine (March 1979)
- Administrative Implications of Neglecting Training Programs - LAW AND ORDER Magazine (April 1979)
- The Physiology of Training - LAW AND ORDER Magazine (June 1979)
- Psycho-Motor Skill Design Instruction - LAW AND ORDER Magazine (September 1979)
- The Role of Stress in Psycho-Motor Skill Training - LAW AND ORDER Magazine (October 1979)
- Principles of Training System Design - LAW AND ORDER Magazine (November 1979)
- Training or Technology: The Administrator's Dilemma - LAW AND ORDER Magazine (January 1980)
- The Delusion of Economical Training - LAW AND ORDER Magazine (April 1980)
- The Medical Implications of Training Techniques - LAW AND ORDER Magazine (May 1980)
- The Seven Components of Power - LAW AND ORDER Magazine (November 1980)
- Developing Policies, Procedures and Rules in THE POLICE YEARBOOK 1988: The Official Proceedings of the 94th IACP Annual Conference (1988)
- Use-of-Force Tactics and Non-Lethal Weaponry in ALERT BULLETIN 3, Americans for Effective Law Enforcement (1988)

RESEARCH GRANTS

- 1975 Law Enforcement Assistance Administration
Institutional Fellowship
University of Nebraska - Omaha
- 1978 Law Enforcement Assistance Administration
Institutional Fellowship
Michigan State University
- 1978 Law Enforcement Assistance Administration
National Competitive Fellowship

- 1979 University of Wisconsin
CAS Curriculum Development Grant
Security Administration Curriculum Design
- 1980 University of Wisconsin
CAS Curriculum Development Grant
Police Officer Survival Workshop
- 1980 University of Wisconsin
CAS Curriculum Development Grant
Organizational Theory Curriculum Design
- 1981 University of Wisconsin
CAS Curriculum Development Grant
Law Enforcement Videotape Project
- 1981 City of Appleton, Wisconsin
Police Management Evaluation Study
- 1981 City of Oshkosh, Wisconsin
Police Management Reorganizational Study
- 1982 University of Wisconsin
Team Training Evaluation Study
- 1982 University of Wisconsin
CAS Curriculum Development Grant
Wisconsin Criminal Justice Education - Needs Analysis
- 1983 University of Wisconsin
CAS Curriculum Development Grant
Personnel Administration Audio Tape Project
- 1983 University of Wisconsin
CAS Curriculum Development Grant
Police Administration Videotape Project
- 1986 State of Arizona
Department of Public Safety (State Police)
Agency Wide Liability Assessment

PROFESSIONAL ORGANIZATIONS

- International Association of Chiefs of Police (Training Committee 1987-1988)
- Justice System Training Association (Director, 1975-1989)
- National Forensic Center (Board of Directors)
- US DEPT of Justice - Criminal Justice Editors Resource Group
- National Tactical Officers Association