



State of West Virginia  
 Department of Administration  
 Purchasing Division  
 2019 Washington Street East  
 Post Office Box 50130  
 Charleston, WV 25305-0130

### Request for Quotation

RFQ NUMBER  
**DPS1011**

SE  
**1**

ADDRESS CORRESPONDENCE TO ATTENTION OF  
**JOHN ABBOTT**  
**304-558-2544**

VENDOR

**RFQ COPY**  
**TYPE NAME/ADDRESS HERE**

Communication Service, Inc.  
 12403 MacCorkle Avenue  
 Charleston, WV 25315

SHIP TO

**WEST VIRGINIA STATE POLICE**  
  
**4124 KANAWHA TURNPIKE**  
**SOUTH CHARLESTON, WV**  
**25309 304-746-2141**

DATE PRINTED	TERMS OF SALE	SHIP VIA	F.O.B.	FREIGHT TERMS
10/26/2009	NET 30	Bestway	Destination	INCL

BID OPENING DATE: **11/12/2009** BID OPENING TIME **01:30PM**

LINE	QUANTITY	UOP	CAT NO	ITEM NUMBER	UNIT PRICE	AMOUNT
0001	1	LS		Federal Signal 055-54		\$390,226.00
<p><b>LIGHTS: EMERGENCY AND TROUBLE (AUTOMOTIVE)</b></p> <p>OPEN-END CONTRACT TO PROVIDE EMERGENCY LIGHTING AND WARNING EQUIPMENT FOR THE WEST VIRGINIA STATE POLICE, AND ALL OTHER AUTHORIZED AGENCIES, PER THE SPECIFICATIONS.</p> <p>EXHIBIT 3</p> <p>LIFE OF CONTRACT: <sup>award</sup> THIS CONTRACT BECOMES EFFECTIVE ..... AND EXTENDS FOR A PERIOD OF ONE (1) YEAR OR UNTIL SUCH "REASONABLE TIME" THEREAFTER AS IS NECESSARY TO OBTAIN A NEW CONTRACT OR RENEW THE ORIGINAL CONTRACT. THE "REASONABLE TIME" PERIOD SHALL NOT EXCEED TWELVE (12) MONTHS. DURING THIS "REASONABLE TIME" THE VENDOR MAY TERMINATE THIS CONTRACT FOR ANY REASON UPON GIVING THE DIRECTOR OF PURCHASING 30 DAYS WRITTEN NOTICE.</p> <p>UNLESS SPECIFIC PROVISIONS ARE STIPULATED ELSEWHERE IN THIS CONTRACT DOCUMENT, THE TERMS, CONDITIONS AND PRICING SET HEREIN ARE FIRM FOR THE LIFE OF THE CONTRACT.</p> <p>RENEWAL: THIS CONTRACT MAY BE RENEWED UPON THE MUTUAL WRITTEN CONSENT OF THE SPENDING UNIT AND VENDOR, SUBMITTED TO THE DIRECTOR OF PURCHASING THIRTY (30) DAYS PRIOR TO THE EXPIRATION DATE. SUCH RENEWAL SHALL BE IN ACCORDANCE WITH THE TERMS AND CONDITIONS OF THE ORIGINAL CONTRACT AND SHALL BE LIMITED TO TWO (2) ONE (1) YEAR PERIODS.</p>						

RECEIVED  
 2009 NOV 12 AM 11:46  
 WV PURCHASING  
 DIVISION

SEE REVERSE SIDE FOR TERMS AND CONDITIONS

SIGNATURE <i>Hanna Thayer</i>	TELEPHONE 304-949-4160	DATE 11-11-09
TITLE <i>Office manager</i>	FEIN 55-0547641	ADDRESS CHANGES TO BE NOTED ABOVE

WHEN RESPONDING TO RFQ, INSERT NAME AND ADDRESS IN SPACE ABOVE LABELED 'VENDOR'

**GENERAL TERMS & CONDITIONS  
REQUEST FOR QUOTATION (RFQ) AND REQUEST FOR PROPOSAL (RFP)**

1. Awards will be made in the best interest of the State of West Virginia
2. The State may accept or reject in part, or in whole, any bid.
3. All quotations are governed by the **West Virginia Code** and the **Legislative Rules** of the Purchasing Division.
4. Prior to any award, the apparent successful vendor must be properly registered with the Purchasing Division and have paid the required \$125 fee.
5. All services performed or goods delivered under State Purchase Order/Contracts are to be continued for the term of the Purchase Order/Contracts, contingent upon funds being appropriated by the Legislature or otherwise being made available. In the event funds are not appropriated or otherwise available for these services or goods, this Purchase Order/Contract becomes void and of no effect after June 30.
6. Payment may only be made after the delivery and acceptance of goods or services.
7. Interest may be paid for late payment in accordance with the **West Virginia Code**.
8. Vendor preference will be granted upon written request in accordance with the **West Virginia Code**
9. The State of West Virginia is exempt from federal and state taxes and will not pay or reimburse such taxes.
10. The Director of Purchasing may cancel any Purchase Order/Contract upon 30 days written notice to the seller.
11. The laws of the State of West Virginia and the **Legislative Rules** of the Purchasing Division shall govern all rights and duties under the Contract, including without limitation the validity of this Purchase Order/Contract.
12. Any reference to automatic renewal is hereby deleted. The Contract may be renewed only upon mutual written agreement of the parties.
13. **BANKRUPTCY:** In the event the vendor/contractor files for bankruptcy protection, the State may deem this contract null and void, and terminate such contract without further order.
14. **HIPAA BUSINESS ASSOCIATE ADDENDUM:** The West Virginia State Government HIPAA Business Associate Addendum (BAA), approved by the Attorney General, and available online at the Purchasing Division's web site (<http://www.state.wv.us/admin/purchase/vrc/hipaa.htm>) is hereby made part of the agreement. Provided that, the Agency meets the definition of a Cover Entity (45 CFR §160.103) and will be disclosing Protected Health Information (45 CFR §160.103) to the vendor.
15. **WEST VIRGINIA ALCOHOL & DRUG-FREE WORKPLACE ACT:** If this Contract constitutes a public improvement construction contract as set forth in Article 1D, Chapter 21 of the West Virginia Code ("The West Virginia Alcohol and Drug-Free Workplace Act"), then the following language shall hereby become part of this Contract: "The contractor and its subcontractors shall implement and maintain a written drug-free workplace policy in compliance with the West Virginia Alcohol and Drug-Free Workplace Act, as set forth in Article 1D, Chapter 21 of the West Virginia Code. The contractor and its subcontractors shall provide a sworn statement in writing, under the penalties of perjury, that they maintain a valid drug-free work place policy in compliance with the West Virginia and Drug-Free Workplace Act. It is understood and agreed that this Contract shall be cancelled by the awarding authority if the Contractor: 1) Fails to implement its drug-free workplace policy; 2) Fails to provide information regarding implementation of the contractor's drug-free workplace policy at the request of the public authority; or 3) Provides to the public authority false information regarding the contractor's drug-free workplace policy."

---

**INSTRUCTIONS TO BIDDERS**

1. Use the quotation forms provided by the Purchasing Division.
2. **SPECIFICATIONS:** Items offered must be in compliance with the specifications. Any deviation from the specifications must be clearly indicated by the bidder. Alternates offered by the bidder as **EQUAL** to the specifications must be clearly defined. A bidder offering an alternate should attach complete specifications and literature to the bid. The Purchasing Division may waive minor deviations to specifications.
3. Complete all sections of the quotation form.
4. Unit prices shall prevail in case of discrepancy.
5. All quotations are considered F.O.B. destination unless alternate shipping terms are clearly identified in the quotation.
6. **BID SUBMISSION:** All quotations must be delivered by the bidder to the office listed below prior to the date and time of the bid opening. Failure of the bidder to deliver the quotations on time will result in bid disqualifications: Department of Administration, Purchasing Division, 2019 Washington Street East, P.O. Box 50130, Charleston, WV 25305-0130



State of West Virginia  
 Department of Administration  
 Purchasing Division  
 2019 Washington Street East  
 Post Office Box 50130  
 Charleston, WV 25305-0130

# Request for Quotation

RFQ NUMBER  
**DPS1011**

PAGE  
**2**

ADDRESS CORRESPONDENCE TO ATTENTION OF  
**JOHN ABBOTT  
 304-558-2544**

RFQ COPY  
 TYPE NAME/ADDRESS HERE

PURCHASING

SHIP TO

**WEST VIRGINIA STATE POLICE**  
  
**4124 KANAWHA TURNPIKE  
 SOUTH CHARLESTON, WV  
 25309 304-746-2141**

DATE PRINTED	TERMS OF SALE	SHIP VIA	F.O.B.	FREIGHT TERMS
10/26/2009				
BID OPENING DATE: 11/12/2009		BID OPENING TIME 01:30PM		

LINE	QUANTITY	UCP	CAT. NO.	ITEM NUMBER	UNIT PRICE	AMOUNT
<p><b>CANCELLATION:</b> THE DIRECTOR OF PURCHASING RESERVES THE RIGHT TO CANCEL THIS CONTRACT IMMEDIATELY UPON WRITTEN NOTICE TO THE VENDOR IF THE COMMODITIES AND/OR SERVICES SUPPLIED ARE OF AN INFERIOR QUALITY OR DO NOT CONFORM TO THE SPECIFICATIONS OF THE BID AND CONTRACT HEREIN.</p> <p><b>OPEN MARKET CLAUSE:</b> THE DIRECTOR OF PURCHASING MAY AUTHORIZE A SPENDING UNIT TO PURCHASE ON THE OPEN MARKET, WITHOUT THE FILING OF A REQUISITION OR COST ESTIMATE, ITEMS SPECIFIED ON THIS CONTRACT FOR IMMEDIATE DELIVERY IN EMERGENCIES DUE TO UNFORESEEN CAUSES (INCLUDING BUT NOT LIMITED TO DELAYS IN TRANSPORTATION OR AN UNANTICIPATED INCREASE IN THE VOLUME OF WORK.)</p> <p><b>QUANTITIES:</b> QUANTITIES LISTED IN THE REQUISITION ARE APPROXIMATIONS ONLY, BASED ON ESTIMATES SUPPLIED BY THE STATE SPENDING UNIT. IT IS UNDERSTOOD AND AGREED THAT THE CONTRACT SHALL COVER THE QUANTITIES ACTUALLY ORDERED FOR DELIVERY DURING THE TERM OF THE CONTRACT, WHETHER MORE OR LESS THAN THE QUANTITIES SHOWN.</p> <p><b>ORDERING PROCEDURE:</b> SPENDING UNIT(S) SHALL ISSUE A WRITTEN STATE CONTRACT ORDER (FORM NUMBER WV-39) TO THE VENDOR FOR COMMODITIES COVERED BY THIS CONTRACT. THE ORIGINAL COPY OF THE WV-39 SHALL BE MAILED TO THE VENDOR AS AUTHORIZATION FOR SHIPMENT, A SECOND COPY MAILED TO THE PURCHASING DIVISION, AND A THIRD COPY RETAINED BY THE SPENDING UNIT.</p> <p><b>BANKRUPTCY:</b> IN THE EVENT THE VENDOR/CONTRACTOR FILES FOR BANKRUPTCY PROTECTION, THE STATE MAY DEEM THE CONTRACT NULL AND VOID, AND TERMINATE SUCH CONTRACT WITHOUT FURTHER ORDER.</p>						

SEE REVERSE SIDE FOR TERMS AND CONDITIONS

SIGNATURE	TELEPHONE	DATE
TITLE	FEIN	ADDRESS CHANGES TO BE NOTED ABOVE

WHEN RESPONDING TO RFQ, INSERT NAME AND ADDRESS IN SPACE ABOVE LABELED 'VENDOR'



State of West Virginia  
 Department of Administration  
 Purchasing Division  
 2019 Washington Street East  
 Post Office Box 50130  
 Charleston, WV 25305-0130

# Request for Quotation

RFQ NUMBER
DPS1011

PAGE
3

ADDRESS CORRESPONDENCE TO ATTENTION OF:
JOHN ABBOTT 304-558-2544

RFQ COPY  
 TYPE NAME/ADDRESS HERE

COUNTY

SHIP TO

WEST VIRGINIA STATE POLICE  
  
 4124 KANAWHA TURNPIKE  
 SOUTH CHARLESTON, WV  
 25309 304-746-2141

DATE PRINTED	TERMS OF SALE	SHIP VIA	F.O.B.	FREIGHT TERMS
10/26/2009				

BID OPENING DATE: 11/12/2009 BID OPENING TIME 01:30PM

LINE	QUANTITY	UOP	CAT NO	ITEM NUMBER	UNIT PRICE	AMOUNT
<p>THE TERMS AND CONDITIONS CONTAINED IN THIS CONTRACT SHALL SUPERSEDE ANY AND ALL SUBSEQUENT TERMS AND CONDITIONS WHICH MAY APPEAR ON ANY ATTACHED PRINTED DOCUMENTS SUCH AS PRICE LISTS, ORDER FORMS, SALES AGREEMENTS OR MAINTENANCE AGREEMENTS, INCLUDING ANY ELECTRONIC MEDIUM SUCH AS CD-ROM.</p> <p>REV. 05/26/2009</p> <p>EXHIBIT 4</p> <p>LOCAL GOVERNMENT BODIES: UNLESS THE VENDOR INDICATES IN THE BID HIS REFUSAL TO EXTEND THE PRICES, TERMS, AND CONDITIONS OF THE BID TO COUNTY, SCHOOL, MUNICIPAL AND OTHER LOCAL GOVERNMENT BODIES, THE BID SHALL EXTEND TO POLITICAL SUBDIVISIONS OF THE STATE OF WEST VIRGINIA. IF THE VENDOR DOES NOT WISH TO EXTEND THE PRICES, TERMS, AND CONDITIONS OF THE BID TO ALL POLITICAL SUBDIVISIONS OF THE STATE, THE VENDOR MUST CLEARLY INDICATE SUCH REFUSAL IN HIS BID. SUCH REFUSAL SHALL NOT PREJUDICE THE AWARD OF THIS CONTRACT IN ANY MANNER.</p> <p>REV. 3/88</p> <p>PURCHASING CARD ACCEPTANCE: THE STATE OF WEST VIRGINIA CURRENTLY UTILIZES A VISA PURCHASING CARD PROGRAM WHICH IS ISSUED THROUGH A BANK. THE SUCCESSFUL VENDOR MUST ACCEPT THE STATE OF WEST VIRGINIA VISA PURCHASING CARD FOR PAYMENT OF ALL ORDERS PLACED BY ANY STATE AGENCY AS A CONDITION OF AWARD.</p> <p>NOTICE</p> <p>A SIGNED BID MUST BE SUBMITTED TO:</p>						

SEE REVERSE SIDE FOR TERMS AND CONDITIONS

SIGNATURE	TELEPHONE	DATE
-----------	-----------	------

TITLE	FEIN	ADDRESS CHANGES TO BE NOTED ABOVE
-------	------	-----------------------------------

WHEN RESPONDING TO RFQ, INSERT NAME AND ADDRESS IN SPACE ABOVE LABELED 'VENDOR'



State of West Virginia  
 Department of Administration  
 Purchasing Division  
 2019 Washington Street East  
 Post Office Box 50130  
 Charleston, WV 25305-0130

### Request for Quotation

RFQ NUMBER  
**DPS1011**

PAGE  
**4**

ADDRESS CORRESPONDENCE TO ATTENTION OF  
**JOHN ABBOTT**  
**304-558-2544**

RFQ COPY

TYPE NAME/ADDRESS HERE

SHIP TO

**WEST VIRGINIA STATE POLICE**  
  
**4124 KANAWHA TURNPIKE**  
**SOUTH CHARLESTON, WV**  
**25309 304-746-2141**

DATE PRINTED	TERMS OF SALE	SHIP VIA	F.O.B.	FREIGHT TERMS
10/26/2009				

BID OPENING DATE: **11/12/2009** BID OPENING TIME **01:30PM**

LINE	QUANTITY	UOP	CAT NO	ITEM NUMBER	UNIT PRICE	AMOUNT
DEPARTMENT OF ADMINISTRATION PURCHASING DIVISION BUILDING 15 2019 WASHINGTON STREET, EAST CHARLESTON, WV 25305-0130						
THE BID SHOULD CONTAIN THIS INFORMATION ON THE FACE OF THE ENVELOPE OR THE BID MAY NOT BE CONSIDERED:  SEALED BID						
BUYER:				JOHN ABBOTT (32)-----		
RFQ. NO.:				DPS1011-----		
BID OPENING DATE:				11/12/2009-----		
BID OPENING TIME:				1:30 PM-----		
PLEASE PROVIDE A FAX NUMBER IN CASE IT IS NECESSARY TO CONTACT YOU REGARDING YOUR BID:  ----- 304-949-4164 -----						
CONTACT PERSON (PLEASE PRINT CLEARLY):				-----		
				Donna Thaxton -----		

SEE REVERSE SIDE FOR TERMS AND CONDITIONS

SIGNATURE		TELEPHONE		DATE
TITLE	FEIN	ADDRESS CHANGES TO BE NOTED ABOVE		

WHEN RESPONDING TO RFQ, INSERT NAME AND ADDRESS IN SPACE ABOVE LABELED 'VENDOR'

## SPECIFICATIONS FOR EMERGENCY VEHICLE LIGHTING AND WARNING EQUIPMENT

The West Virginia State Police is requesting competitive bids for police emergency vehicle lighting and warning equipment as per the attached specifications. The contract shall be available for use by all other entities of state government, as well as counties and municipalities.

All vendors bidding on any equipment listed in these specifications are required to submit in writing, an indication as to if the product(s) they are bidding meets or exceeds ALL the specifications set forth in these specifications for those item(s) they are bidding on. If a vendor bids a product which does not meet ALL the specifications as outlined for that item, the vendor is required to submit their exceptions in writing being specific listing the item and line-specification(s) they are taking exception to. Vendors are also required to submit a product sheet for each item bid, which is to include at a minimum: picture, manufacturer, model number, and general specifications for the item. **Any bid received without this required written documentation will not be considered for bid award.**

The agency has listed multiple items in this bid specification and has numbered each as a separate item. The agency reserves the right to make multiple or split awards from this single solicitation.

YES      NO

### 1. SIREN AND LIGHT CONTROL SYSTEM (TIER-1)

1.0.1 The emergency vehicle siren and light control system shall be as specified below and shall be the Federal Signal PA640 Series or equivalent. All major components must be designed and manufactured in the United States of America. Bids that contain major components manufactured outside the United States of America are not acceptable.

\_\_\_\_\_ x \_\_\_\_\_

#### 1.1.0 SIREN AMPLIFIER:

1.1.1 The remote siren system shall consist of a control head with a 4-position slide switch and a minimum of six (6) push button switches, and a combined electronic siren amplifier and relays in one (1) module capable of providing a minimum of a five (5) function siren, plus radio repeat and public address

\_\_\_\_\_ x \_\_\_\_\_

1.1.2 The system shall be capable of being utilized as a single unit or by separating the control head and the amplifier/relay module (ARM) and mounting the pieces separately to conserve space needed in the front of the vehicle.

  X   \_\_\_\_\_

1.1.3 The system shall have a small single connector to connect the control head to the AMP/Relay Module as described in the following specification.

  X   \_\_\_\_\_

1.1.4 The system shall be constructed to be immune to radio frequency interference (RFI) and electromagnetic interference (EMI). The system shall be constructed in a manner to not create any radio frequency interference (RFI) and electromagnetic interference (EMI).

  X   \_\_\_\_\_

1.2.0 CONTROL HEAD:

1.2.1 The control head shall be supplied with an adjustable universal style mounting bracket and a semi-flush trim ring. All necessary mounting hardware for these mounts shall also be supplied. The unit shall be no larger than 2-1/2 inches deep (including slide switch) x 3-3/8 inches high x 6 8 inches wide (excluding mounting hardware).

  X   \_\_\_\_\_

1.2.2 The control head connector shall be built into the back of the unit. The connector shall be designed so it cannot be easily pulled apart from the connection. The location of this connector shall not be in a location that is visible or interferes with installation of the unit into a console.

  X   \_\_\_\_\_

1.2.3 The control head must incorporate a single circuit board design. Each push button switch must have both tactile and audible ("beep") feedback to the user. Control heads that do not have this feature are not acceptable since the driver would have to take his eyes off the road to determine if the switch is operating. Control heads with multi-board designs are unacceptable; since the internal interconnect cable can become disconnected unknowingly, with service not user friendly.

  X   \_\_\_\_\_

1.2.4 Each tactile switch must be backlit and each switch must include a separate LED or lamp "On" indicator above or on the switch face that provides enough light to allow it to be seen even in bright day light without washing out, or the switch must change colors to indicate it is activated "On". Both the switch backlight and the LED "On" indicator must have a low intensity feature for ease of night time visibility. Units that are not backlit, or which do not have a separate LED "On" indicator visible in bright day light or do not change colors to indicate it is "On" are not acceptable. Each of the push button switches shall have its own back-lit legend tab. This will help in identifying the functions that are in use. There shall be a minimum of (36) legends to choose from

1.2.5 The control head shall be supplied completely assembled with a minimum of the following:

- 4-position positive detent slide switch (programmable)
- Six (6) (minimum) push button switches located in a row that directly interface with the control head electronics and operates external equipment such as lightbars, headlight flashers, etc.
- 5-position siren control knob
- PA/Volume control knob

Noise-canceling microphone with 3 ft. coiled cord

1.2.6 The control head shall have a rotary style switch with a minimum of five (5) positions to control the siren which shall include the following: *Wail*, *Yelp*, *Piercer (or Hi/Lo)*, *Manual*, and *Airhorn*. There shall also be a minimum of five (5) push button switches in a row which are programmable for On/Off; Momentary; or 8 Second Timer. There shall also be a slide switch containing a minimum of 4-positions (Off, 1, 2, & 3) which shall be located on the left-hand side of the device. The Horn Ring Transfer shall be transferred when the slide switch is in position-3 and will scroll through the siren tones, starting with the tone chosen on the selector switch



1.3.0 AMPLIFIER/RELAY MODULE (ARM):

1.3.1 The aluminum/metal housing of the ARM shall have built-in ventilator ports to assist in keeping all internal components cool for long life and reliability. It shall be supplied with all necessary mounting hardware. The amplifier shall measure no more than approximately 7 inches wide x 7-3/4 inches deep x 3.0 inches high

X \_\_\_\_\_

1.3.2 The ARM operates on a 12 volt negative ground automotive electrical system. The amplifier shall be designed to operate from a minimum of 11V to 15V and shall be reverse-polarity protected to ensure that the unit will not be damaged if polarity is reversed.

X \_\_\_\_\_

1.3.3 The ARM shall have all power and device control connectors on the rear of the module.

X \_\_\_\_\_

1.3.4 The siren shall be capable of operating a minimum of one (1) 100 watt speakers and must meet Class "A" requirements with most 100 watt speakers. If the siren speaker(s) or any speaker wires are shorted, the siren amplifier will shut down to avoid damage to the circuitry until the short circuit is removed.

X \_\_\_\_\_

1.3.5 The PIT ("Push To Talk") switch on the microphone will override all siren functions.

X \_\_\_\_\_

1.4.0 WARRANTY:

1.4.1 The system specified shall be warranted to the user to be free of defects of material or workmanship for a minimum period of two (2) years from date of purchase

X \_\_\_\_\_

1.4.2 The amplifier shall be warranted for a minimum period of five (5) years.

\_\_\_\_\_

1.4.3 Written proof of this warranty shall be provided with bid.

\_\_\_\_\_

2. SIREN AND LIGHT CONTROL SYSTEM (TIER-2)

2.0.1 The emergency vehicle siren and light control system shall be as specified below and shall be either the Federal Signal SmartSiren or Whelen Model CCSRN2 Siren/Switch, and SA315P Speaker or equivalent. All major components must be designed and manufactured in the United States of America. Bids that contain major components manufactured outside the United States of America are not acceptable.   X   \_\_\_\_\_

2.1.0 SIREN AMPLIFIER:

2.1.1 The remote siren system shall consist of a control head with a 4-position slide switch and a minimum of seventeen (17) push button switches, and a combined electronic siren amplifier and relays in one (1) module.   X   \_\_\_\_\_

2.1.2 The system shall utilize a small single connector to connect the control head to the AMP/Relay Module as described in the following specification   X   \_\_\_\_\_

2.1.3 The system shall be constructed to be immune to radio frequency interference (RFI) and electromagnetic interference (EMI). The system shall be constructed in a manner to not create any radio frequency interference (RFI) and electromagnetic interference (EMI).   X   \_\_\_\_\_

2.2.0 CONTROL HEAD:

2.2.1 The control head shall be supplied with an adjustable universal style mounting bracket, a semi-flush trim ring, and a pivot or swing style bracket for mounting the control head in front of the am/fm radio which is designed so the control head can easily be rotated out of the way of the am/fm radio controls. All necessary mounting hardware for these mounts shall also be supplied. The unit shall be no larger than 2.15 inches deep (including slide switch) x 3-5/8 inches high x 6-13/16 inches wide (excluding mounting hardware)   X   \_\_\_\_\_

2.2.2 The control head connector shall be built into the back or end of the unit. The connector shall be designed so it cannot be easily pulled apart from the connection. The location of this connector shall not be in a location that is visible or interferes with installation of the unit into a console.

X

2.2.3 The control head must incorporate a single circuit board design. Each push button switch must have both tactile and audible ("beep") feedback to the user. Control heads that do not have this feature are not acceptable since the driver would have to take his eyes off the road to determine if the switch is operating. Control heads with multi-board designs are unacceptable; since the internal interconnect cable can become disconnected unknowingly, with service not user friendly

X

2.2.4 Each tactile switch must be backlit and each switch must include a separate LED "On" indicator above or on the switch face that provides enough light to allow it to be seen even in bright day light without washing out, or the switch must change colors to indicate it is activated "On". Both the switch backlight and the LED "On" indicator must have a low intensity feature for ease of night time visibility. Units that are not backlit, or which do not have a separate LED "On" indicator visible in bright day light or do not change colors to indicate it is "On" are not acceptable. Each of the push button switches shall have its own back-lit legend tab. This will help in identifying the functions that are in use. There shall be a minimum of (136) legends to choose from.

X

2.2.5 The control head shall be supplied completely assembled with a 4-position (positive detent) slide switch that is programmable, and minimum of eighteen (17) push button switches that directly interface with the control head electronics and operates external equipment such as lightbars, headlight flashers, Traffic Advisors, etc.

X

2.2.6 The control head shall have a minimum of eight (8) On/Off siren switches located in a row or grouped together to include: *Stand-By*, *Radio Repeat*, *Hands-Free*, *Wail*, *Yelp*, *Piercer (or Hi/Lo)*, *Manual*, and *Airhorn*. There shall also be a minimum of four (4) switches in a row or grouped together to include: *Traffic Advisor Direction Control (Left, Right, Split)*, *Aux 1*, *Aux 2*, and *Low Power*. There shall also be a minimum of five (5) switches in a row or grouped together which will activate a minimum of (4) 10 amp circuits and a minimum of (1) switch which will operate an open, dry contact relay in the AMP/Relay Module. All five (5) switches are programmable for On/Off; Momentary; or 8 Second Timer. There shall also be a slide switch containing a minimum of 4-positions which shall be located on the left-hand side of the device. It shall be programmable as independent switches or progressive, and will have (2) 20 amp and (1) 40 amp positions. The slide switch must be programmable to include either *Wail* with *Yelp* override or *Hands Free* operation in any one of the three "On" positions. Each slide switch position will also be programmable to operate Traffic Advisor flasher mode, Aux1/Aux2, Low Power and all five (5) programmable switches

          X          

2.3.0 AMPLIFIER/RELAY MODULE (ARM):

2.3.1 The aluminum/metal housing of the ARM shall have built-in ventilator ports to assist in keeping all internal components cool for long life and reliability. It shall be supplied with a minimum of two (2) mounting feet that must be built into the design of the assembly for superior strength, and includes all necessary mounting hardware. The amplifier shall measure no more than approximately 7 inches wide x 7 inches deep x 3.0 inches high.

          X          

2.3.2 The ARM operates on a 12 volt negative ground automotive electrical system. The amplifier shall be designed to operate from a minimum of 11V to 15V and shall be reverse-polarity protected to ensure that the unit will not be damaged if polarity is reversed.

          X

2.3.3 The ARM shall have all power and control connectors on one side of the module. There shall be a minimum of three (3) heavy duty Anderson style power connectors for main power to the amplifier and for power distribution to other warning accessories. Units that require that the module be opened to change fuses or make any power or control connections are not acceptable. X

2.3.4 The siren shall be capable of operating one (1) or two (2) 100 watt speakers and must meet Class "A" requirements with most 100 watt speakers. If the siren speaker(s) or any speaker wires are shorted, the siren amplifier will shut down to avoid damage to the circuitry until the short circuit is removed. X

2.3.5 In the *Hands-Free* mode, the siren shall be in a "Stand By" state, awaiting electronic commands. The siren will progressively change from *Wail* to *Yelp* to *Piercer* (Tone 3) by simply tapping the horn ring only once, each time. This provides the driver with a means of changing siren selections while keeping both hands on the wheel, and eyes on the road at all times. X

2.3.6 The ARM shall consist of two (2) parts: a Top and a Bottom aluminum housing which fits together in a clamshell design. The design shall be constructed so the amplifier and logic boards for the system are contained in either the top or the bottom of the housing and the relay outputs and optional Traffic Advisor modules (if required) are contained in the other portion of the housing. This design will assure ease of service to all internal components in a non-stacking PC board design; which is unacceptable since it is very difficult to easily service the unit. X

2.3.7 System programming shall be accomplished either through the use of a computer using a USB or Ethernet interface to the system, or through the use of the control head by pushing a sequence of switches to enter the programming mode of the system. The program must be able to be extracted from one system and inserted into an unlimited number of systems. Systems that allow changes or through internal DIP switches are not acceptable. X

2.3.8 The unit must be supplied complete with a noise-canceling microphone with at least a 3 ft. coiled cord. If the microphone connection is located on the ARM and not the Control Head, then a 20 ft. (minimum) microphone extension cable shall be provided. The PTT ("Push To Talk") switch on the microphone will override all siren functions. The volume control for the microphone and radio rebroadcast shall have an adjustable volume control that is easily adjustable without the need to open the ARM.

X \_\_\_\_\_

2.4.0 WARRANTY:

2.4.1 The system specified shall be warranted to the user to be free of defects of material or workmanship for a minimum period of two (2) years from date of purchase.

\_\_\_\_\_

2.4.2 The amplifier shall be warranted for a minimum period of five (5) years

\_\_\_\_\_

2.4.3 Written proof of this warranty shall be provided with bid.

\_\_\_\_\_

3. HANDHELD PROGRAMMABLE SIREN AND LIGHT CONTROL SYSTEM (TIER 3)

3.1.0 The emergency vehicle siren and light control system shall be as specified below and shall be the Whelen HHS2200 Siren or equivalent. All major components must be designed and manufactured in the United States of America. Bids that contain major components manufactured outside the United States of America are not acceptable.

X \_\_\_\_\_

3.2.0 SIREN AMPLIFIER:

3.2.1 The Programmable remote siren system shall consist of a Handheld control with a three (3) progressive push button switch and nine (9) non-progressive push button switches, and a combined electronic siren amplifier and relays in (1) module. It utilizes a small single phone style connector that plugs into the amplifier/relay module as described as follows.

\_\_\_\_\_

3.3.0 CONTROL HEAD

3.3.1 The handheld control head shall be supplied with all necessary mounting hardware. The unit shall be no larger than 1 1/2 inches deep (including slide switch) x 5 3/8 inches high x 2 25/64 inches wide (excluding mounting hardware).

3.3.2 The control head must incorporate a single circuit board design equipped with a solid silicon rubber overlay for maximum moisture resistance from water or beverage spills. Each switch will also produce a "click" sound when pushed On/Off as positive feedback method that the switch has been changed. Control heads that do not have this feature are not acceptable since the driver would have to take his eyes off the road to determine if the switch is operating. The handheld control head must include a microphone with a push-to-talk switch located on the left side of the unit.

3.3.3 Each Tactile switch must be backlit in Green, must change color to Red when activated and must provide enough light to allow it to be seen in bright daylight without washing out. Units that are not backlit or which do not change color when activated are not acceptable. Each of the push button switches shall have its own backlit legend tab. This will help in identifying the functions that are in use.

3.3.4 There shall be more than (225) legends to choose from. A Windows based program shall allow full custom set-up configuration of each of the twelve (12) buttons to control all lights and siren functions, including the ability to enable and disable functions. Siren/Switch systems that are not completely programmable are not acceptable.

3.3.5 The default setting shall be as follows:

The control head shall have three(3) On/Off progressive switches across the *FIRST* row:

Button 1 activates Outlet 1

Button 2 activates Outlets 1 and 2

Button 3 shall activate Outlets 1, 2 and 3, with the option of operating the siren via a dip switch located on the amplifier module.

\_\_\_\_\_

The *SECOND* row shall contain three (3) siren switches:

\_\_\_\_\_

Button 4 activates the siren's Hands-Free mode. In this mode, the "wail" tone is activated but the horn ring, or Push Button 5. This will also activate Outlet 9.

\_\_\_\_\_

Button 5 with button 4 active, button 5 (or the horn ring) will cycle from "wail" to "yelp". If button 4 inactive button 5 will generate a tone that ramps up and sustains a specific pitch until the button is released.

\_\_\_\_\_

Button 6 will activate an airhorn until released

\_\_\_\_\_

The siren contains a *THIRD* row of three (3) switches.

\_\_\_\_\_

Button 7 shall produce a "wail" tone. Pressing button 5 will change the tone to "yelp".

\_\_\_\_\_

Button 8 will activate radio rebroadcast.

\_\_\_\_\_

Button 9 will cycle through Outlet 4,5, 4+5, and deactivates 4+5.

\_\_\_\_\_

The *FOURTH* row of three (3) switches with pushes shall operate as follows:

\_\_\_\_\_

Button 10 activates output 6

\_\_\_\_\_

Button 11 activates output 7

\_\_\_\_\_

Button 12 activates output 8.

\_\_\_\_\_

To deactivate all functions, press and hold any button for more than two (2) seconds.

\_\_\_\_\_



3.4.0 AMPLIFIER/RELAY MODULE (ARM):

- 3.4.1 The aluminum housing of the ARM shall have built-in mounting feet that shall be built into the design of the assembly for superior strength, and includes all necessary mounting hardware. The amplifier shall measure approximately 8.082 inches wide x 7.275 inches deep x 2.56 inches high. \_\_\_\_\_
- 3.4.2 The ARM operates on a 12 volt negative ground automotive electrical system. The amplifier shall be designed to operate from 10V to 16V and shall be reverse polarity protected to ensure that the unit will not be damaged if polarity is reversed. \_\_\_\_\_
- 3.4.3 The siren shall be capable of operating one (1) or two (2) 100 watt speakers and must meet Class "A" requirements with most 100 watt speakers. If the siren speaker(s) or any speaker wires are shorted, the siren amplifier will shutdown (via fuse) to avoid damage to the circuitry until the short circuit is removed. \_\_\_\_\_
- 3.4.4 In the Hands-Free mode, the siren shall be in a "Stand By" state (Button 4 activated), awaiting electronic commands. The siren will progressively change from Wail to Yelp by simply tapping the horn ring only once, each time. This eliminates the need for one-handed driving while fumbling for the siren controls (both hands stay on the wheel, and eyes are on the road at all times). \_\_\_\_\_
- 3.4.5 The ARM shall consist of two (2) parts: a Top and a Bottom aluminum housing which fits together in a clamshell design. This design will assure ease of service to all internal components in a non-stacking PC board design. Designs that require stacking of PC boards are unacceptable, since it is very difficult to easily service the unit. \_\_\_\_\_

3.4.6 The unit shall be supplied complete with a handheld control with a noise-cancelling microphone. A three (3) ft. coiled cord and a twenty (20) ft. extension cable shall be provided. The PTI ("Push To Talk") switch on the microphone will override all siren functions. The microphone and radio rebroadcast circuits shall have an "adjustable Preset" volume control that is recessed in the side of the amplifier for ease of adjustment without the need to open the ARM.

X \_\_\_\_\_

3.5.0 WARRANTY:

3.5.1 The siren system shall be warranted by the manufacturer to the user directly to be free from defects of material or workmanship for a period of 24 months from the date of purchase. The siren amplifier shall be warranted for a period of five (5) years from date of purchase. Written proof of this warranty by the manufacturer must be furnished by the bidder and attached to the bid.

X \_\_\_\_\_

3.5.2 The manufacturer shall provide a 24 month warranty on both parts and factory labor. This shall include 48 hour factory turnaround repair service. Out-of-warranty product shall receive the same quality service and be repaired at a flat service rate of \$75.00, which includes shipping/handling fee for each unit returned (excluding new or necessary hardware such as lenses, flash tubes, etc.)

\_\_\_\_\_ X \_\_\_\_\_

3.5.3 The successful bidder must be the manufacturer or an authorized stocking distributor for Whelen Engineering Company or equivalent, and stock sufficient quantities of service parts to maintain the needs of the department within forty-eight (48) hours after call.

X \_\_\_\_\_

4. SWITCHED CONTROL CENTER

4.0.1 The switched control center shall be as specified below.

4.1.0 DESIGN:

4.1.1 The housing of the control center shall be constructed of steel/metal and shall have a black-epoxy finish, measuring no larger than 2-1/4 inches high x 6 inches wide x 4-3/4 inches deep. Control centers that are larger than these dimensions are not acceptable.   X   \_\_\_\_\_

4.1.2 The switched control center shall consist of a pre-wired control box with a minimum of six (6) rocker style or push button switches, which illuminate when function controlled is in use.   X   \_\_\_\_\_

4.1.3 The control center shall have a legend window with backlight directly below or above each switch for easy visibility in any light. There shall be a minimum of fifty (50) legend tabs supplied with the control center.   X   \_\_\_\_\_

4.1.4 The control center shall have a backlight circuit which can be connected to the vehicle's dimmer switch to control the backlight intensity of the unit.   X   \_\_\_\_\_

4.1.5 The control center shall be fully wired, with one (1) single pole - single throw 40 amp and five (5) single pole - single throw 20 amp rocker style or push button switches. Switches shall be fused independently with spade-type fuses which are to be located on a fuse strip on the rear of the unit.   X   \_\_\_\_\_

4.1.6 The control center shall utilize a "captive" style terminal block located on the rear of the unit for securing the wiring of devices controlled by the control center.   X   \_\_\_\_\_

4.1.7 The control center shall be constructed to be immune to radio frequency interference (RFI) and electromagnetic interference (EMI). The system shall be constructed in a manner to not create any radio frequency interference (RFI) and electromagnetic interference (EMI).   X   \_\_\_\_\_

4.2.0 MOUNTING:

4.2.1 There shall be a universal bail bracket mount (black in color) supplied with the control center for mounting.   X   \_\_\_\_\_

4.3.0 WARRANTY:

4.3.1 The system shall be warranted by the manufacturer to the user directly to be free from defects of material or workmanship for a minimum period of two (2) years from date of purchase. Written proof of this warranty by the manufacturer must be furnished by the bidder and attached to the bid.

  X   \_\_\_\_\_

**5. SIREN SPEAKER**

5.0.1 The Siren Speaker with mounting bracket shall be as specified below. The speaker must be designed and manufactured in the United States of America, including the housing and mounting bracket.

  X   \_\_\_\_\_

5.1.0 DESIGN:

5.1.1 The electronic speaker must utilize a multi-port reentrant design, which produces higher sound levels as well as clear sound. Single or dual reentrant speakers are unacceptable.

  X   \_\_\_\_\_

5.1.2 The siren speaker must meet or exceed SAE requirements for a "Class A" speaker when used with a standard siren amplifier. The speaker must produce a minimum sound level of 120 to 122 dB at 10 feet. Siren speakers that do not produce a minimum of 120 dB are not acceptable.

  X   \_\_\_\_\_

5.1.3 The speaker shall be made of a polycarbonate or solid aluminum in a black non-corrosive finish and be of compact size, measuring no larger than 6-1/4 inches H x 6-1/2 inches W x 3-1/4 inches D. Speakers that are larger than these dimensions are not acceptable.

  X   \_\_\_\_\_

5.1.4 The siren speaker shall have only two main parts: the housing that contains the Projector, resonant chamber and reentrant parts; and the speaker driver.

  X   \_\_\_\_\_

5.1.5 The speaker shall utilize a high efficiency 100 watt driver. This will allow for a maximum sound output and clarity. Driver must be easily replaceable by the end user. Units that require that the speaker be sent to a service center for repair are unacceptable.

  X   \_\_\_\_\_

5.1.6 The 100 watt driver shall be compressed style and shall bolt on to the Projector. The driver shall not be of threaded throat style, since this type may either untwist over the course of time and cause speaker failure, or seize together due to oxidation, thereby becoming impossible to repair or replace

  X   \_\_\_\_\_

5.2.0 MOUNTING:

5.2.1 A variety of speaker mounting brackets (minimum 15) must be available for most late model vehicles. A complete list of these mounting brackets must be provided with the bid. Speakers with only a few vehicle-specific mounting brackets are unacceptable because of the wide range of vehicles the department utilizes.

  X   \_\_\_\_\_

5.2.2 There shall be one (1) speaker bracket supplied with each speaker, which shall be designated at the time of order.

  X   \_\_\_\_\_

5.3.0 WARRANTY:

5.3.1 The speaker driver must have a minimum of a two (2) year warranty. A copy of the manufacturer's official warranty statement must be supplied with the bid

  X   \_\_\_\_\_

6. LED LIGHTBAR

6.0.1 The emergency lightbar as requested herein shall be as specified below and shall be the Whelen LFL Liberty Super-LED Lightbar or equivalent. All electronics shall be contained inside the lightbar. There shall be no mechanical drive motors, chains, belts, or gears. The lightbar shall be based on a standard production model of the manufacturer. Official printed product literature clearly explaining all necessary features of the lightbar as contained in this bid, as well as an official printed "Warranty Policy" stating both warranty/non-warranty terms and conditions, is required for this bid. All major components must be designed and manufactured in the United States of America, including LED panels, I/O cards, etc. Bids that contain major components manufactured outside of the United States are not acceptable.

  X   \_\_\_\_\_

- 6.0.2 The main structure of the lightbar shall be of heavy gauge extruded aluminum top and bottom, and must be designed for superior structural strength. Lightbars with plastic polycarbonate tops are not acceptable. The lightbar shall house all electronic components. The lightbar shall measure approximately 49.75 inches in length with a maximum height of 2.55 inches and a maximum width of 12 inches, excluding mounting brackets. The lightbar must have Hi/Low power control of all LED modules. Lightbars that do not offer this feature are not acceptable. X \_\_\_\_\_
  
- 6.0.3 The lightbar shall contain one (1) control module I/O board which shall contain all the electronics required to operate all internal lightheads. This single module is required for ease of servicing the lightbar. Lightbars with multiple boards are unacceptable. X \_\_\_\_\_
  
- 6.0.4 Each I/O card shall produce a high energy envelope of four (4) pulses to each LED head at a rate of 75 envelopes per minute per head. There shall be a minimum of twelve (12) flash patterns to choose from. Each pair of linear LED lamps must be capable of activating independently of each other. X \_\_\_\_\_
  
- 6.0.5 The I/O Card shall drive the LED light heads offering Hi/Low capabilities. The Halogen Lightheads shall operate from the I/O board allowing the takedowns and alleys to both steady burn and flash, and permitting the alleys to be controlled individually. The Traffic Advisor will only require two (2) wire control (no control head) when operated from the I/O board. The linear LED corners will be capable of a cruise light application. The lights will remain activated at a low power level, producing a cruise light mode. Lightbars without these features are not acceptable. X \_\_\_\_\_

6.0.6 The lightbar's primary warning shall have a maximum of four (4) linear LED modules [1 in each corner] that meets SAE Class 1 requirements. Lightbars that utilize more than four modules to meet SAE Class I requirements are not acceptable. *A copy of the Testing Lab or AMECA Certificate confirming that the lightbar conforms to SAE Class I requirements is required with this bid. Failure to submit this document will disqualify the bidder.* Lightbars that do not use Linear LED's as primary warning are not acceptable. The lightbar shall have linear LED modules in the four corners. Each Linear LED corner module shall consist of a minimum of twelve (12) LED's permanently mounted within a single "removable" highly mirrored parabolic reflector for maximum light output. Corner light modules that utilize multiple reflectors or mirrors are not acceptable since they do not provide a true even light spread. The twelve (12) LED's shall be mounted in a straight line and have a single diffuser panel mounted in front of them for maximum light output. X \_\_\_\_\_

6.0.7 The I/O module shall be 100% solid state with built-in reverse-polarity protection and output-short protection. They shall operate from 10-16 VDC with no degradation in flash rate, and shall operate through a temperature range of -22 degrees Fahrenheit to 140 degrees Fahrenheit. The lightbar shall be designed to have up to eight (8) lamps to the front, eight (8) lamps to the rear, and one (1) on each end. Each lamp module position shall have a choice of five (5) single-layer colored lens sections, independent of the others. The lenses shall be constructed of polycarbonate with built-in spreader optics and a horizontal non-fluted strip across the center of each lens for maximum light output at the "zero" H-V point. The LED panel must be mounted within the lightbar. Systems in which the LED panel/lens assembly makes up the outside configuration of the lightbar (clear outer lenses and colored inner filters) are not acceptable. X \_\_\_\_\_

6.0.8 The lightbar shall have:

Six (6) Linear LED's to the front (Blue)

Eight (8) inboard Linear LED's to the rear  
(1 Red/1 Amber/6 Blue) X \_\_\_\_\_

6.0.9 All inboard linear LED panels shall be of the same design. All inboard lightheads must be of the same series LED's whether LED or halogen to allow for placement of these lightheads in any inboard position. All LED modules must produce a minimum 180 degree light pattern. LED panels that do not produce significant light output at 45 degrees are not acceptable. The lightbar shall also contain Lightbar Options listed below. No substitute options will be accepted. X \_\_\_\_\_

6.0.10 The lightbar must utilize lenses that may be replaced without removing the lightbar from the roof of the vehicle. It is preferred that the lenses slide into a track and be held in place by two end caps that secure to the lightbar via four screws each. Lightbars that utilize domes held in place by clips are unacceptable as the domes will allow sunlight to wash out the warning light, and clips can fail over time. The outer lens color shall be clear. The use of clear outer domes with colored filter is not acceptable. X \_\_\_\_\_

6.0.11 The lightbar shall contain a mounting kit to adapt the lightbar to most late model vehicles, and there shall be a "high-rise" mount available to raise the lightbar approximately five (5) inches to improve the rear view of the lightbar on vehicles with varying roof contours. Y \_\_\_\_\_

6.1.0 LIGHTBAR OPTIONS

6.1.1 Option #2 (Takedowns):  
 The lightbar shall contain two (2) 27 watt (minimum) halogen lamps that must allow for steady burn, as well as flashing takedowns. The halogen lamps shall be snap-in style and must be mounted inside the lightbar in a deep-dish, highly mirrored reflector for maximum light output. The two (2) halogens shall come "ON" together as take-downs or alternately flash, and must be controlled by the lightbar's I/O board. X \_\_\_\_\_

6.1.2 Option #3 (Alley Lights):  
 The lightbar shall contain two (2) MR11 halogen lamps that must allow for independent control of each lamp in a steady burn mode, and shall alternately flash. The halogen lamps shall be mounted inside the lightbar by snap-in style and must be mounted in a deep-dish, highly mirrored reflector for maximum light output. The two (2) MR11 halogens must be controlled by the lightbar's I/O board. X \_\_\_\_\_



6.2.0 WARRANTY

6.2.1 The system shall be warranted by the manufacturer to the user directly to be free from defects of material or workmanship for a minimum period of two (2) years from date of purchase, with the exception of optical plastic parts and halogen bulbs. LED's shall be warranted for a minimum period of five (5) years. Written proof of this warranty by the manufacturer must be furnished by the bidder and attached to the bid.

  x   \_\_\_\_\_

6.2.2 The manufacturer shall provide a minimum two (2) years warranty on both parts and factory labor. This shall include forty-eight (48) hour factory turnaround repair service. Out-of-warranty product shall receive the same quality service and be repaired at a flat service rate, which includes a shipping/handling fee for each unit returned (excluding new or necessary hardware such as lenses, flash tubes, etc.).

  x   \_\_\_\_\_

6.2.3 The successful bidder must be the manufacturer or an authorized stocking distributor of the product, and shall stock sufficient quantities of service parts to maintain the needs of the department within forty-eight (48) hours after call.

  x   \_\_\_\_\_

7. LED LOW PROFILE INTERIOR LIGHTBAR

7.0.1 The low profile LED Interior Warning Light shall be as specified below and shall be the Galls LED Interior Warning Light or Mallimar Warning Phantom Model ULB42-BB-WV-2, manufactured by Star Headlight & Lantern Co., Inc. or equivalent. The unit must be completely designed and manufactured in the United States of America. No major subassemblies manufactured offshore shall be utilized. This includes, but is not limited to, housings, LED PC boards, lenses, etc

  x   \_\_\_\_\_

7.1.0 BASIC STRUCTURAL DESIGN:

7.1.1 The device shall be housed in a heavy duty polycarbonate housing. The unit shall appear to be void of color until the LED's are turned on. The unit must be supplied with universal mounting brackets for ease of mounting to most vehicles.

  x   \_\_\_\_\_

7.1.2 The device shall be no shorter than 42 inches and no longer than 45.50 inches in length, no more than 1-1/8 inches in height, and no more than 7.00 inches in width; and be designed to fit snugly to the windshield to prevent flash back into the passenger compartment.

X \_\_\_\_\_

7.2.0 WARNING LAMP MODULES:

7.2.1 The device shall contain a minimum of ten (10) Blue LED panels. Each panel shall utilize high intensity LED's (Light Emitting Diodes). The unit must have a minimum of eight (8) wide angle Linear-LED modules facing straight out of the housing and two (2) Linear-LED modules at 45 degrees. These LED's shall have a life expectancy of at least 100,000 hours. Each LED panel shall utilize a minimum of twenty four (24) LED's.

X \_\_\_\_\_

7.2.2 Each light head shall contain a minimum of twenty four (24) individual LED's in two rows of twelve (12) that have a life expectancy of at least 100,000 hours.

X \_\_\_\_\_

7.2.3 The maximum amperage draw in any mode shall be no more than 1 amp at 12.8 volts DC. The amp draw is critical because the unit is designed to be used in a parked vehicle with its ignition off for long periods of time.

X \_\_\_\_\_

7.2.4 The LED Interior Warning light shall include a minimum eight (8) foot power cable with a cigarette style plug.

X \_\_\_\_\_

7.2.5 The LED Interior Warning light shall be equipped with two (2) buttons (one to turn on/off the unit, and one to control the 27 warning patterns) installed in the housing in a location readily accessible to the operator of the vehicle.

X \_\_\_\_\_

7.3.0 WARRANTY:

7.3.1 The system specified shall be warranted to the user to be free of defects of material or workmanship for a minimum period of seven (7) years from date of purchase.

X X

7.3.2 LED panels shall be warranted for a minimum period of seven (7) years. Written proof of this warranty shall be provided with bid.

\_\_\_\_\_ X \_\_\_\_\_

**8. LED INTERIOR REAR DECK LIGHT**

8.0.1 The interior lighthouse shall contain one (1) LED lighthouse as specified below and shall be the Whelen Talon Model: TLNVCV5BB or equivalent, and must be supplied with all standard mounting hardware. All major components such as LED panels, housings, and lenses must be designed and manufactured in the United States of America or the bid will be considered non-responsive

X \_\_\_\_\_

**8.1.0 REAR DECK LED LIGHTHEAD:**

8.1.1 The system shall contain two (2) LED modules (BLUE), each of which contain a minimum of six (6) individual LEDs (Minimum Generation 3.5) that are mounted in a single highly polished reflector in a straight line and having a design to provide considerable light at a 90 degree angle. Units that do not utilize this linear design in a single reflector are unacceptable. The two (2) Blue panels shall each contain its own clear outer lens for a stealth look, and shall be mounted in a black polycarbonate housing for long life and durability. The units will be mounted inside the passenger compartment; therefore, for passenger safety, units that are housed in metal housings are unacceptable. The unit shall come complete with a glamour cap and mounting bracket to allow the unit to be mounted around the vehicle's third brake light and eliminate flash back.

X \_\_\_\_\_

8.1.2 There shall be a minimum of fourteen (14) flash patterns to choose from, along with Hi/Low power; both of which must be controlled by an external wire. The unit will have a non-volatile memory and stay in the pattern selected until changed by the operator.

X \_\_\_\_\_

8.1.3 The assembly shall be no larger than 19.5 inches long x 2.6 inches high with the mounting bracket, and 5.8 inches deep with the shroud. The lighthouse shall be molded polycarbonate with rounded over corners. Units made of a metal substance or with non-rounded corners are unacceptable.

X \_\_\_\_\_

8.2.0 WARRANTY:

8.2.1 The system shall be warranted by the manufacturer to the user directly to be free from defects of material or workmanship for a minimum period of two (2) years from date of purchase (It shall be understood that no warranty is offered on optical plastic parts). LED modules shall be warranted for a minimum period of five (5) years. Written proof of this warranty by the manufacturer must be furnished by the bidder and attached to the bid.

Y \_\_\_\_\_

8.2.2 The manufacturer shall provide a minimum two (2) years warranty on both parts and labor. This shall include forty-eight (48) hour factory turnaround repair service. Out-of-warranty product shall receive the same quality service and be repaired at a flat service rate, which includes a shipping/handling fee for each unit returned (excluding new or necessary hardware such as lenses, flash tubes, etc.).

X \_\_\_\_\_

8.2.3 All successful bidders must be an authorized stocking distributor for the manufacturer of the product line, and stock sufficient quantities of service parts to maintain the needs of the department within 72 hours after call.

X \_\_\_\_\_

9. SURFACE MOUNT DIRECTIONAL LED ASSEMBLY (TIER-1)

9.0.1 The LED assembly shall be the Whelen TIR3 Super-LED, Model RSB03ZCR or equivalent. The assembly shall be a self-contained directional LED lighthouse assembly containing a minimum of three (3) LED's and shall come complete with a built-in flasher and with all standard mounting hardware and brackets to mount the unit to any flat surface. The unit must be completely designed and manufactured within the United States of America. No major subassemblies manufactured offshore shall be utilized.

X \_\_\_\_\_

9.1.0 DESIGN:

9.1.1 The directional head assembly shall be supplied with an aluminum mounting plate and a black flange as standard and will be completely sealed for long life and durability. The unit must be designed to mount to any flat surface.

X \_\_\_\_\_

9.1.2 The lighthouse assembly shall measure a maximum 3.6 inches long x 1.3 inch protrusion, x 1.3 inches high, larger units will not be accepted. Size is a major issue due to specific mounting location needs of the agency.

  X   \_\_\_\_\_

9.1.3 The directional head assembly shall have an LED panel which contains a minimum of three (3) individual Blue LED's (Minimum Generation 3.5) in a straight row that have a life expectancy of at least 100,000 hours. The panel shall contain ballast and TIR lens, and shall be mounted to an aluminum base, and must be completely encapsulated for long life and durability. The unit shall draw no more than 25 amps.

  X   \_\_\_\_\_

9.1.4 There must be four (4) wires exiting the unit, one for each of the following: Power, Ground, Flash Pattern and Synchronize. The Flash Pattern wire will allow a choice of five flash patterns and steady burn options to choose from. Each of the five patterns shall have a Phase 1 and Phase 2. When using multiple lighthouses, the synchronized wires are attached to simultaneously or alternately flash Phase 1 and Phase 2 of each of the five patterns. The unit will have a non-volatile memory and stay in the pattern selected. Units that do not have a synchronization feature are not acceptable.

  X   \_\_\_\_\_

9.1.5 The lens must be made of clear polycarbonate and must have a smooth outer lens (for self cleaning) with built-in optics for horizontal mounting to insure maximum light output. The lens must be permanently imprinted with the appropriate SAE number.

  X   \_\_\_\_\_

9.2.0 MOUNTING OPTIONS:

9.2.1 The specified LED panels shall come with all standard mounting hardware and brackets to mount the unit to any flat surface

  X   \_\_\_\_\_

9.2.2 At a minimum the following additional mounting assemblies shall be available:

  X   \_\_\_\_\_

Aluminum bracket to measure a maximum of 4.0 inches long x 1.37 inch protrusion x 1.6 inches high.

  X   \_\_\_\_\_

Black polycarbonate with a chrome finish and shall measure a maximum of 3.6 inches long x .625 protrusion x 1.3 inches high.

Black polycarbonate designed to hold two (2) LED panels (as specified) for surface mount application and shall measure a maximum of 3.6 inches long x .625 protrusion x 2.5 inches high.

X \_\_\_\_\_

Aluminum grille mounting bracket that fits one (1) LED panels (as specified) for the Ford *Crown Victoria*. The bracket must be easily installed in the grille area of the vehicle, with dimensions of 3-3/4 inches Length x 2-1/8 Height x 1 inch Depth. The bracket will be supplied with all hardware to insure proper installation.

X \_\_\_\_\_

9.3.0 WARRANTY:

9.3.1 LED modules shall be warranted for a period of five (5) years. Written proof of this warranty by the manufacturer must be furnished by the bidder and attached to the bid.

X \_\_\_\_\_

9.3.2 All successful bidders must be an authorized distributor for the product bid and stock sufficient quantities of service parts to maintain the needs of the department within twenty-four (24) hours after called.

X \_\_\_\_\_

10. SURFACE MOUNT DIRECTIONAL LED ASSEMBLY (TIER-2)

10.0.1 The LED assembly shall be the Whelen TIR6 Super-LED, Model 50B03ZBR or equivalent. The LED assembly shall be a self-contained directional LED lighthouse assembly containing a minimum of six (6) LED's and shall come complete with a built-in flasher and with all standard mounting hardware and brackets to mount the unit to any flat surface. The unit must be completely designed and manufactured within the United States of America.

X \_\_\_\_\_

10 1 0 DESIGN:

10.1.1 The directional head assembly shall be built with an aluminum backing plate and will be completely sealed for long life and durability. The unit must be designed to mount to any flat surface and shall come with all necessary mounting hardware and brackets to mount the unit to any flat surface.

X \_\_\_\_\_

10.1.2 The lighthouse assembly shall measure a maximum 5 inches long x 1 5/8 inch high. Size is a major issue due to mounting locations.

X \_\_\_\_\_

10.1.3 The directional head assembly shall have an LED panel which contains a minimum of six (6) individual Blue LED's (Minimum Generation 3.5) in a staggered row that have a life expectancy of at least 100,000 hours. The panel shall contain ballast and LED lens, and shall be mounted to an aluminum base. The unit shall draw no more than .50 amps.

X \_\_\_\_\_

10.1.4 There must be four (4) wires exiting the unit, one for each of the following: Power, Ground, Flash Pattern and Synchronize. The Flash Pattern wire will allow a choice of five flash patterns and steady burn options to choose from. Each of the five patterns shall have a Phase 1 and Phase 2. When using multiple lighthouses, the synchronized wires are attached to simultaneously or alternately flash Phase 1 and Phase 2 of each of the five patterns. The unit will have a non-volatile memory and stay in the pattern selected. Units that do not have a synchronization feature are not acceptable.

X \_\_\_\_\_

10.1.5 The lens must be removable, made of clear or blue polycarbonate and must have a smooth outer lens (for self cleaning) with built-in optics for horizontal mounting to insure maximum light output. The lens must be permanently imprinted with the appropriate SAE number.

X \_\_\_\_\_

10.2.0 MOUNTING OPTIONS:

10.2.1 The LED assembly shall come with all standard mounting hardware and brackets to mount the unit to any flat surface.

  ✓   \_\_\_\_\_

10.2.2 There must also be available an aluminum grille mounting bracket that fits one LED assembly as specified for easy installation of the assembly into the grille area of a Ford Crown Victoria.

  x   \_\_\_\_\_

10.3.0 WARRANTY:

10.3.1 LED modules shall be warranted for a period of five (5) years. Written proof of this warranty by the manufacturer must be furnished by the bidder and attached to the bid.

  λ   \_\_\_\_\_

10.3.2 All successful bidders must be an authorized distributor for the product bid and stock sufficient quantities of service parts to maintain the needs of the department within twenty-four (24) hours after called.

  x   \_\_\_\_\_



DPS 1011 Emergency Vehicle Lighting Equipment					
Item #	Description	Quantity	Model #	Unit Price	Extended Price
1	Siren and Light Control System (Tier-1)	100	PA640	\$ 321.04	\$ 32,104.00
2	Siren and Light Control System (Tier-2)	100	SS2000	\$ 661.50	\$ 66,150.00
3	Handheld Programmable Siren and Light Control System (Tier-3)	100	65003	\$ 311.85	\$ 31,185.00
4	Switched Control Center	100	SW300	\$ 82.03	\$ 8,203.00
5	Siren Speaker	100	ES100	\$ 128.47	\$ 12,847.00
6	LED Lightbar	100	Legend	\$ 1359.75	\$ 135,900.00
	Option #1 - Takedown Lights	100		\$	\$
	Option #2 - Ailey Lights	100		\$	\$
7	LED Low Profile Interior Lightbar	100	Solaris ILS	\$ 703.50	\$ 70,350.00
8	LED Interior Rear Deck Light	100	329003-33	\$ 189.34	\$ 18,934.00
9	LED surface Mount Assembly (Tier-1)	100	IPX300	\$ 51.82	\$ 5,182.00
10	LED surface Mount Assembly (Tier-2)	100	VPX300	\$ 93.71	\$ 9,371.00
				<b>Total</b>	<b>\$ 390,226.00</b>

Failure to use this form may result in disqualification.

**Bidder / Vendor Information:**

Name: Communication Service, Inc.  
 Address: 12403 MacCorkle Avenue  
Charleston, WV 25315  
 Phone#: 304-949-4160  
 Email Address: csiomt@suddenlinkmail.com

**Contract Coordinator Information:**

Name: \_\_\_\_\_  
 Address: \_\_\_\_\_  
 Phone#: \_\_\_\_\_  
 Email Address: \_\_\_\_\_

\* Quantities are estimated annual usage for bidding purposes and bidder's information

VENDOR PREFERENCE CERTIFICATE

Certification and application\* is hereby made for Preference in accordance with West Virginia Code, §5A-3-37 (Does not apply to construction contracts) West Virginia Code, §5A-3-37, provides an opportunity for qualifying vendors to request (at the time of bid) preference for their residency status. Such preference is an evaluation method only and will be applied only to the cost bid in accordance with the West Virginia Code. This certificate for application is to be used to request such preference. The Purchasing Division will make the determination of the Resident Vendor Preference, if applicable.

- 1. Application is made for 2.5% resident vendor preference for the reason checked: Bidder is an individual resident vendor and has resided continuously in West Virginia for four (4) years immediately preceding the date of this certification; or, Bidder is a partnership, association or corporation resident vendor and has maintained its headquarters or principal place of business continuously in West Virginia for four (4) years immediately preceding the date of this certification; or 80% of the ownership interest of Bidder is held by another individual, partnership, association or corporation resident vendor who has maintained its headquarters or principal place of business continuously in West Virginia for four (4) years immediately preceding the date of this certification; or, Bidder is a nonresident vendor which has an affiliate or subsidiary which employs a minimum of one hundred state residents and which has maintained its headquarters or principal place of business within West Virginia continuously for the four (4) years immediately preceding the date of this certification; or,
2. Application is made for 2.5% resident vendor preference for the reason checked: Bidder is a resident vendor who certifies that, during the life of the contract, on average at least 75% of the employees working on the project being bid are residents of West Virginia who have resided in the state continuously for the two years immediately preceding submission of this bid; or,
3. Application is made for 2.5% resident vendor preference for the reason checked: Bidder is a nonresident vendor employing a minimum of one hundred state residents or is a nonresident vendor with an affiliate or subsidiary which maintains its headquarters or principal place of business within West Virginia employing a minimum of one hundred state residents who certifies that, during the life of the contract, on average at least 75% of the employees or Bidder's affiliate's or subsidiary's employees are residents of West Virginia who have resided in the state continuously for the two years immediately preceding submission of this bid; or,
4. XX Application is made for 5% resident vendor preference for the reason checked: Bidder meets either the requirement of both subdivisions (1) and (2) or subdivision (1) and (3) as stated above; or,
5. Application is made for 3.5% resident vendor preference who is a veteran for the reason checked: Bidder is an individual resident vendor who is a veteran of the United States armed forces, the reserves or the National Guard and has resided in West Virginia continuously for the four years immediately preceding the date on which the bid is submitted; or,
6. Application is made for 3.5% resident vendor preference who is a veteran for the reason checked: Bidder is a resident vendor who is a veteran of the United States armed forces, the reserves or the National Guard, if, for purposes of producing or distributing the commodities or completing the project which is the subject of the vendor's bid and continuously over the entire term of the project, on average at least seventy-five percent of the vendor's employees are residents of West Virginia who have resided in the state continuously for the two immediately preceding years.

Bidder understands if the Secretary of Revenue determines that a Bidder receiving preference has failed to continue to meet the requirements for such preference, the Secretary may order the Director of Purchasing to: (a) reject the bid; or (b) assess a penalty against such Bidder in an amount not to exceed 5% of the bid amount and that such penalty will be paid to the contracting agency or deducted from any unpaid balance on the contract or purchase order.

By submission of this certificate, Bidder agrees to disclose any reasonably requested information to the Purchasing Division and authorizes the Department of Revenue to disclose to the Director of Purchasing appropriate information verifying that Bidder has paid the required business taxes, provided that such information does not contain the amounts of taxes paid nor any other information deemed by the Tax Commissioner to be confidential.

Under penalty of law for false swearing (West Virginia Code, §61-5-3), Bidder hereby certifies that this certificate is true and accurate in all respects; and that if a contract is issued to Bidder and if anything contained within this certificate changes during the term of the contract, Bidder will notify the Purchasing Division in writing immediately.

Bidder: Communication Service, Inc. Signed: [Signature]
Date: 11-11-09 Title: Office Manager

\*Check any combination of preference consideration(s) indicated above, which you are entitled to receive

STATE OF WEST VIRGINIA  
Purchasing Division**PURCHASING AFFIDAVIT****VENDOR OWING A DEBT TO THE STATE:**

*West Virginia Code* §5A-3-10a provides that: No contract or renewal of any contract may be awarded by the state or any of its political subdivisions to any vendor or prospective vendor when the vendor or prospective vendor or a related party to the vendor or prospective vendor is a debtor and the debt owed is an amount greater than one thousand dollars in the aggregate.

**PUBLIC IMPROVEMENT CONTRACTS & DRUG-FREE WORKPLACE ACT:**

If this is a solicitation for a public improvement construction contract, the vendor, by its signature below, affirms that it has a written plan for a drug-free workplace policy in compliance with Article 1D, Chapter 21 of the *West Virginia Code*. The vendor **must** make said affirmation with its bid submission. Further, public improvement construction contract may not be awarded to a vendor who does not have a written plan for a drug-free workplace policy in compliance with Article 1D, Chapter 21 of the *West Virginia Code* and who has not submitted that plan to the appropriate contracting authority in timely fashion. For a vendor who is a subcontractor, compliance with Section 5, Article 1D, Chapter 21 of the *West Virginia Code* may take place before their work on the public improvement is begun.

**ANTITRUST:**

In submitting a bid to any agency for the state of West Virginia, the bidder offers and agrees that if the bid is accepted the bidder will convey, sell, assign or transfer to the state of West Virginia all rights, title and interest in and to all causes of action it may now or hereafter acquire under the antitrust laws of the United States and the state of West Virginia for price fixing and/or unreasonable restraints of trade relating to the particular commodities or services purchased or acquired by the state of West Virginia. Such assignment shall be made and become effective at the time the purchasing agency tenders the initial payment to the bidder.

I certify that this bid is made without prior understanding, agreement, or connection with any corporation, firm, limited liability company, partnership or person or entity submitting a bid for the same materials, supplies, equipment or services and is in all respects fair and without collusion or fraud. I further certify that I am authorized to sign the certification on behalf of the bidder or this bid.

**LICENSING:**

Vendors must be licensed and in good standing in accordance with any and all state and local laws and requirements by any state or local agency of West Virginia, including, but not limited to, the West Virginia Secretary of State's Office, the West Virginia Tax Department, West Virginia Insurance Commission, or any other state agencies or political subdivision. Furthermore, the vendor must provide all necessary releases to obtain information to enable the Director or spending unit to verify that the vendor is licensed and in good standing with the above entities.

**CONFIDENTIALITY:**

The vendor agrees that he or she will not disclose to anyone, directly or indirectly, any such personally identifiable information or other confidential information gained from the agency, unless the individual who is the subject of the information consents to the disclosure in writing or the disclosure is made pursuant to the agency's policies, procedures and rules. Vendor further agrees to comply with the Confidentiality Policies and Information Security Accountability Requirements, set forth in <http://www.state.wv.us/admin/purchase/privacy/noticeConfidentiality.pdf>.

Under penalty of law for false swearing (*West Virginia Code* §61-5-3), it is hereby certified that the vendor affirms and acknowledges the information in this affidavit and is in compliance with the requirements as stated.

Vendor's Name: Communication Service, Inc.  
Authorized Signature: *Alana Thayer* Date: 11-11-09



FEDERAL SIGNAL

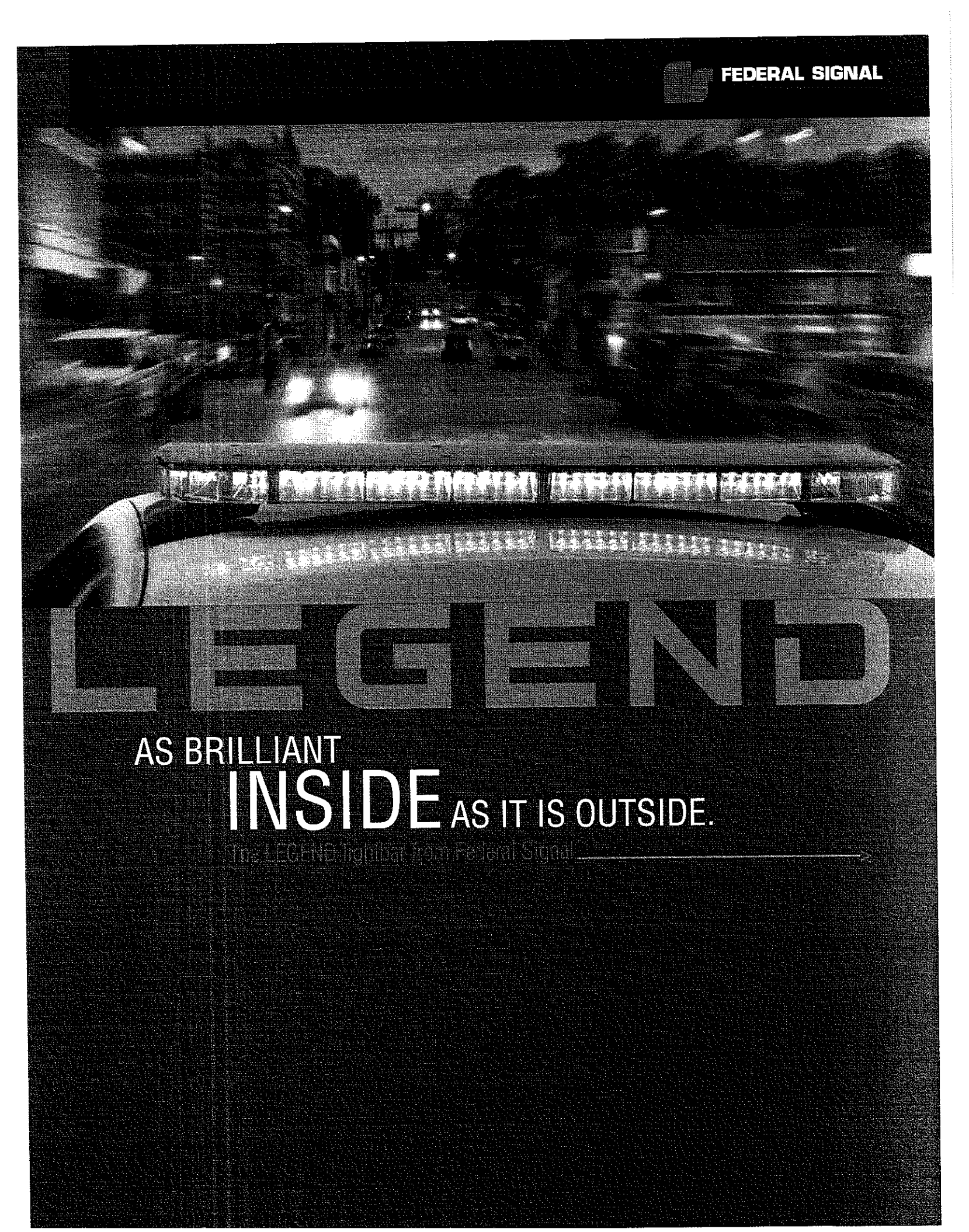

# LEGEND

AS BRILLIANT  
**INSIDE** AS IT IS OUTSIDE.

The LEGEND lightbar from Federal Signal

THE LEGEND™ LIGHTBAR

# BRIGHT NEW THINKING

From the leader in emergency warning technology.

Introducing a brilliant new design for a stealthy appearance.

## > SMARTER

ROC SOLID CONSTRUCTION Patent-pending ROC (Reliable Onboard Circuitry) technology eliminates 85% of potential failure points in the lightbar — reducing repair costs and increasing the hours your emergency vehicles stay on the road.

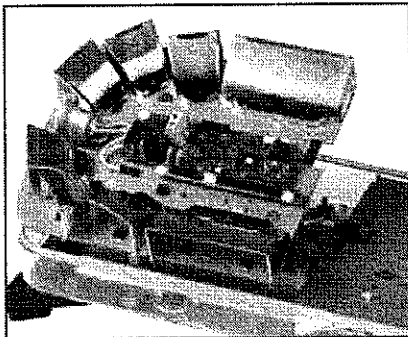

*ROC with the Micro-Processor Controller delivers advanced communication between the controller head and lightbar.*

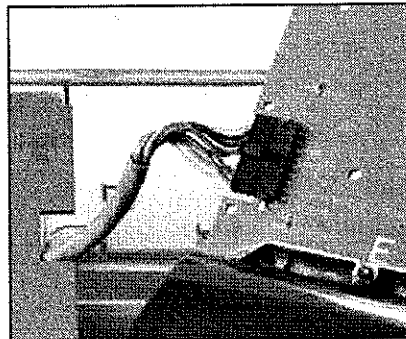

*Minimal Board-to-Board Connections reduce about 85% of potential failure points. ROC uses a printed circuit board in one assembly to significantly reduce the electrical connections found in a typical lightbar.*

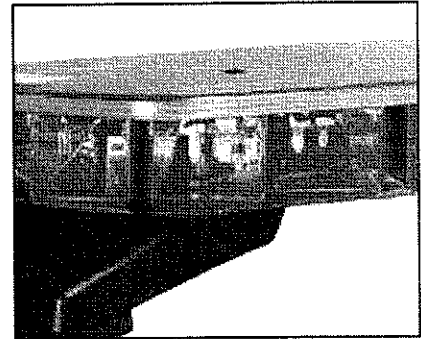

*Solaris Technology and ROC design provide exceptional 360-degree coverage, which eliminates dark spots and creates superior off-axis warning around the lightbar.*

**YESTERDAY'S TECHNOLOGY.** The most common failure points found in a typical lightbar, as shown below, occur between the connector to its light source and the lightbar's power source. With older technology, each light head usually has at least two, sometimes four, connections per light head. ROC technology reduces the number of parts found in a typical lightbar by approximately 65%.

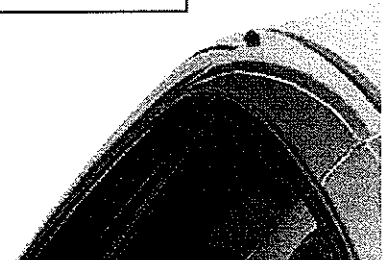
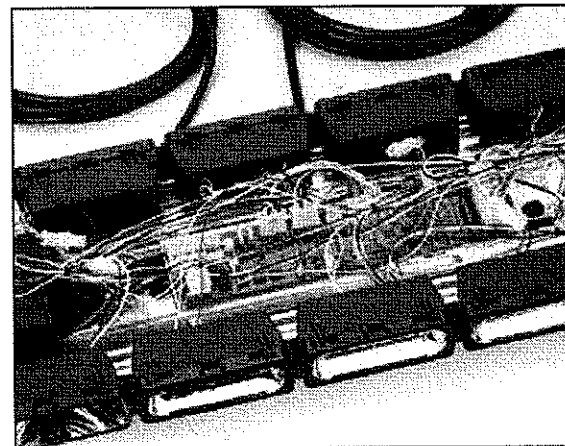
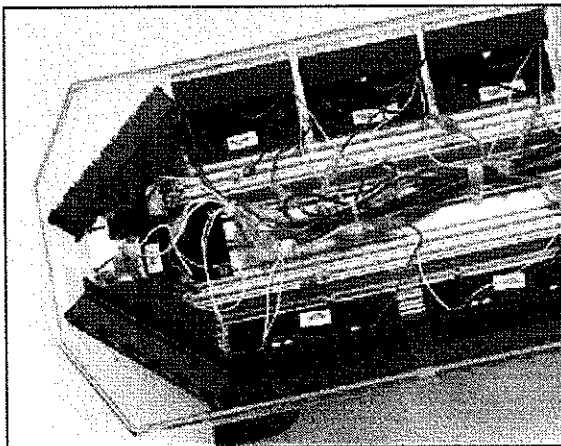

way to improve safety - the Legend from Federal Signal. Featuring a popular, low-profile appearance. The Legend provides 360-degree coverage and superior off-axis warning.

## > SIMPLER

**SIMPLE TO CUSTOMIZE AND CONFIGURE** Legend can be easily reconfigured in minutes, right on the vehicle, without removing and rewiring individual modules. ROC boards are also individually labeled to make reconfiguration easy.

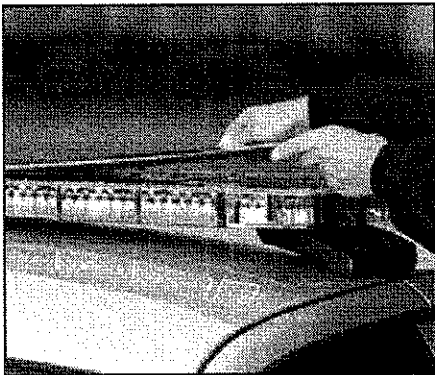

1 Remove the top dome with only four screws

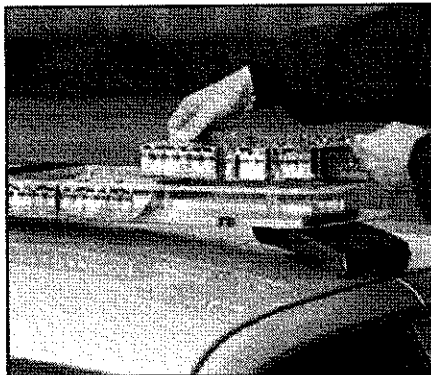

2 Disconnect the ROC board by the 22-gauge wire harness

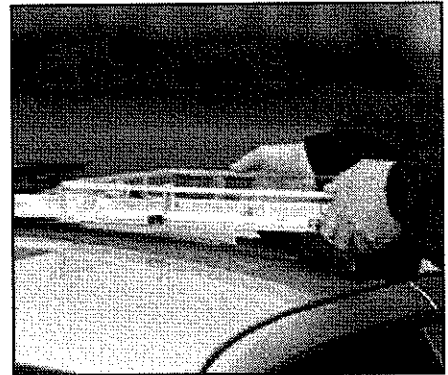

3 The base slides off for quick replacement

### *Internal SignalMaster. Directional Warning*

Legend can be configured for internal Federal Signal SignalMaster control operation. In this mode, an external SignalMaster controller is not required. A simple slide switch activates the lightbar's internal SignalMaster.

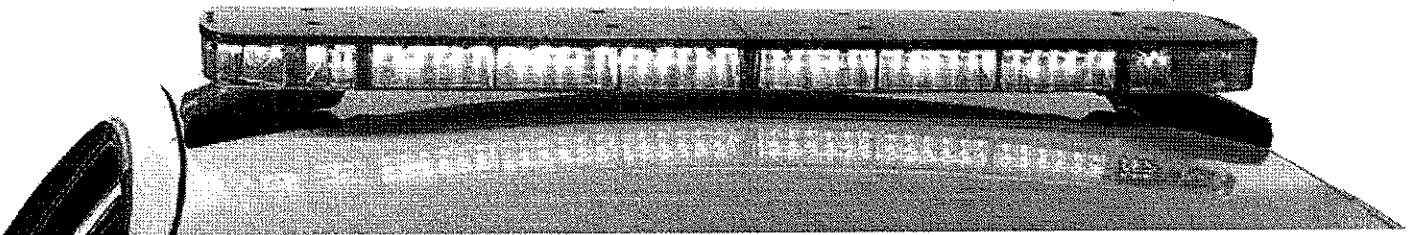

While operating in three priority modes, all modules keep sequence with the flash pattern. Once directional warning is selected, the SignalMaster modules override the current flash pattern.

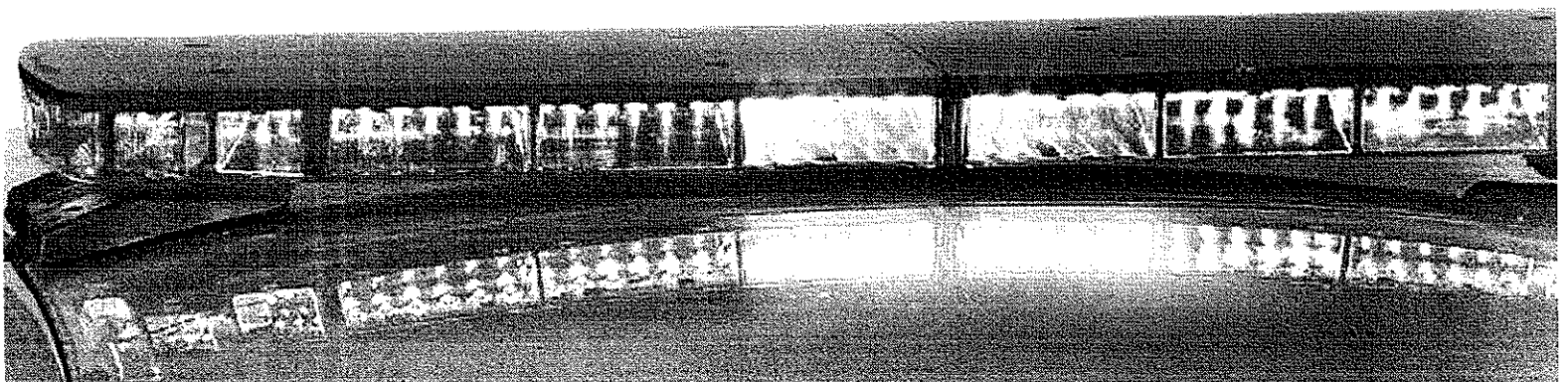



**LEGEND AND RS485 SYSTEM** With the RS485 System, it is fast and easy to clone and duplicate patterns from vehicle to vehicle. The function of each individual light head can be controlled with the RS485 system.

- Four default patterns are included for positions 1, 2, 3 and the intersection clearing mode
- Lightbars are controlled through a standard RS485 bus connection. Protocol is based on SAE J1708 and J1587 standards
- Compact serial interface module is included with every lightbar for those vehicles not equipped to accept RS485 bus connections.
- Built-in SignalMaster directional warning capability is standard with the Legend. SignalMaster patterns can be activated via a standard switch and do not need a separate directional warning controller
- Additional pre-programmed options such as front/rear cut-off, intersection warning, and dimming can easily be programmed into the lightbar operation and cloned from vehicle to vehicle.

## EASY CONFIGURATION

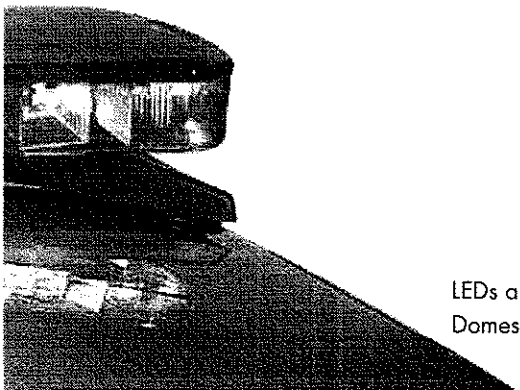
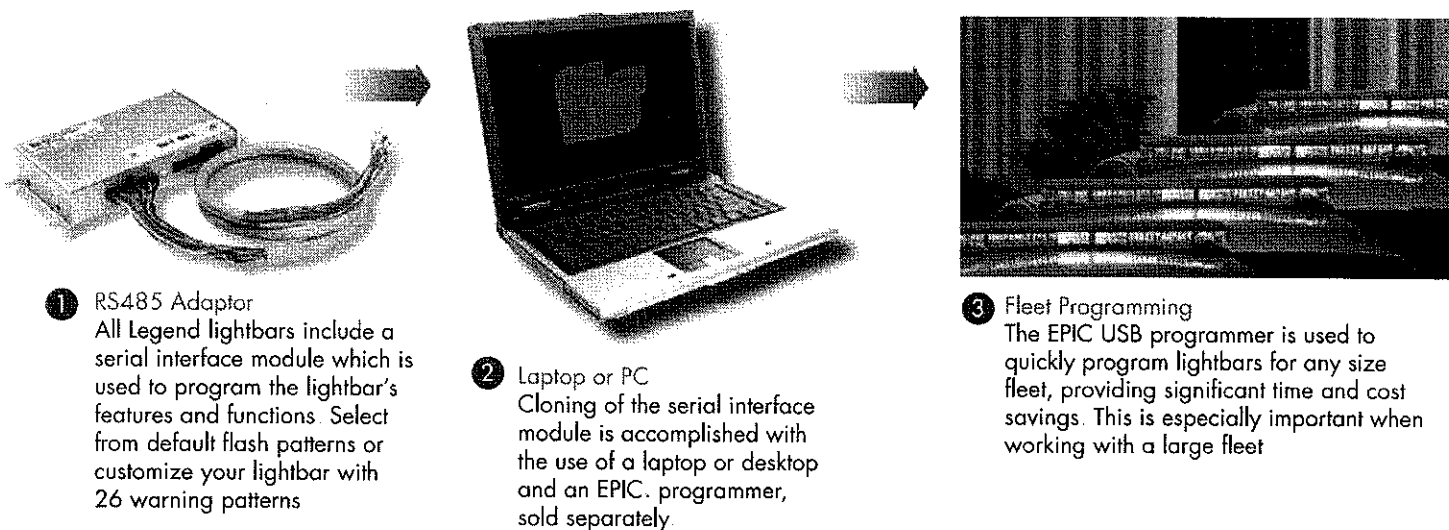

LEDs are offered in red, blue, white, amber, and green  
Domes are available in red, blue, amber, and clear.

# THE LEGEND® LIGHTBAR

## NEW THINKING

From the leader in emergency warning technology.

### SOLARIS - THE BEST AND BRIGHTEST IN LIGHTING TECHNOLOGY

Our patent-pending Federal Signal Solaris design features the latest in LED reflector technology for a bright and intense off-axis light output.



## Optional ultra bright white LED Takedown lights!

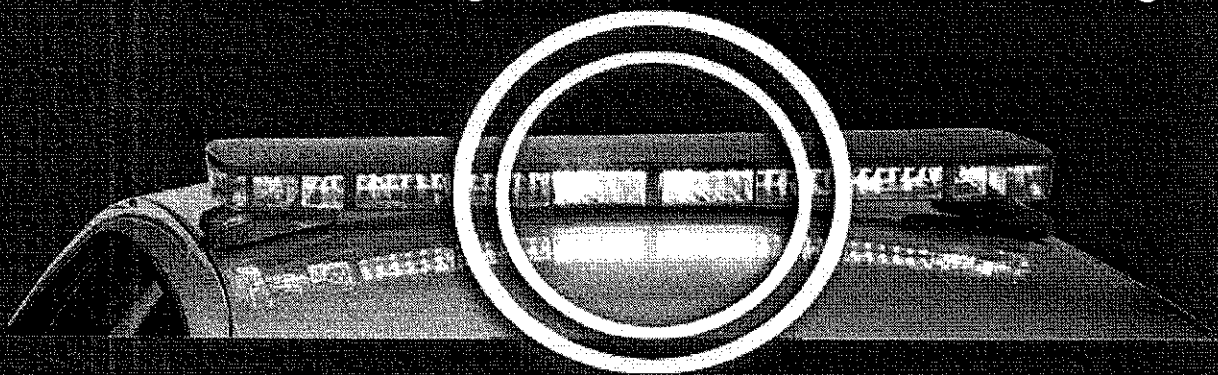

- The brightness of halogens with Federal Signal's patent pending Solaris high performance LED takedowns.
- Solaris reflector design provides focused lighting for increased officer safety and protection.
- LEDs reduce the current draw, freeing up amperage for other essential vehicle equipment.

Note: Halogen takedown lights are also available.

### MORE FEATURES FOR SAFER OPERATION

All Legend lightbars contain an advanced micro-processor controller which provides three modes of operation, a library of flash patterns, adjustable alley and takedown lights (halogen), front/rear cut-off, dimming, and intersection warning.

#### *Dimming Feature for Approaching On-car and Pedestrian Safety*

Operable in modes one and two, the dimming feature reduces light output to half its intensity. For officer safety, the dimming feature is not activated in mode three.

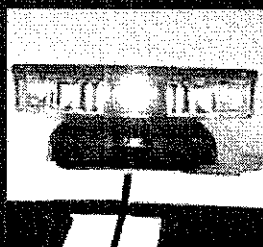

#### *Adjustable Alley and Takedown Lights (Halogen)*

The halogen alley and takedown lights can be adjusted horizontally and vertically to ensure proper visibility.

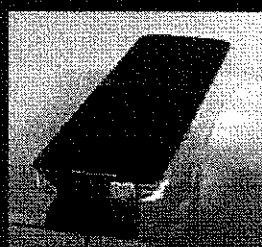

Rear Cut-off

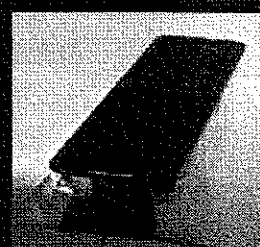

Front Cut-off



## SMARTER, SIMPLER, AND SAFER – DISCOVER THE LEGEND ADVANTAGE

To learn more about what the LEGEND performance can do for you, call 800-264-3578.

### FEDERAL SIGNAL'S ON-LINE LIGHTBAR CONFIGURATOR IS QUICK AND EASY TO USE.

To configure your Legend 24", 45", 53", and 61" lightbars, go to [www.fedsig.com](http://www.fedsig.com). Save, print, or e-mail your configuration to a Federal Signal Customer Support Representative or contact your local distributor today.

Warning Light Specifications				
Lighting Options	Current Draw	Lamp/Technology	Watts	Reflector Style
LED Takedown Light	1.0 A**	Six Gen III high brightness LEDs	-	Offset, compound-curve, polished spot beam reflector
Halogen Takedown Light	3.9 A*	Bi-pin halogen	50	Polished
Alley Light	2.7 A*	Bi-pin halogen	35	Faceted
Solaris LED-Main Lightbar	1.0 A**	Six Gen III high brightness LEDs	-	Offset, compound-curve polished reflector

\* Amperage per pair, with flashing takedown and alley lights.  
\*\* Amperage in steady burn mode

Technical Specifications						
Model	Length	Height	Width	Weight	Operating Voltage	Operating Temperature
LGD24	24.25 in (61.6 cm)	2.5 in (6.4 cm)	11.2 in (28.4 cm)	16.6 lbs*	12.8 VDC	-30°C to +65°C
LGD45	44.5 in (113.0 cm)	2.5 in (6.4 cm)	11.2 in (28.4 cm)	20.4 lbs*	12.8 VDC	-30°C to +65°C
LGD53	52.7 in (133.9 cm)	2.5 in (6.4 cm)	11.2 in (28.4 cm)	24.2 lbs*	12.8 VDC	-30°C to +65°C
LGD61	60.9 in (154.7 cm)	2.5 in (6.4 cm)	11.2 in (28.4 cm)	28.0 lbs*	12.8 VDC	-30°C to +65°C

\* Standard foot included.



**FEDERAL SIGNAL**  
Safety and Security Systems

*Advancing security and well-being.*

2645 Federal Signal Drive, University Park, IL 60466-3195

Tel.: (800) 264-3578 • Fax: (800) 682-8022

[www.fedsig.com](http://www.fedsig.com)

#M1025

Legend, Solaris, Reliable Onboard Circuitry, and SignalMaster are trademarks of Federal Signal Corporation. EPIC is a trademark of Microchip Technology Inc.

©2008 Federal Signal Corporation.

# PA640 SIREN



## Experience Counts

Federal Signal has taken another giant step as the leader in siren electronics technology. Crystal controlled microprocessors, integrated circuits, and silicon based output transistors work together to make the PA640 the most reliable, most versatile totally enclosed siren/light controller available. Years of design and manufacturing experience has allowed Federal Signal to incorporate the most desired features along with advanced electronics into one affordable and compact siren package.

## Functional

PA640 sirens provide 100-watt output and will meet Class A and SAE J1849 requirements for sound when paired with any Federal Signal high output speaker. Every siren comes with its own mounting bracket, hard-wired microphone and is electronically short circuit and reverse polarity protected. The PA640 can operate from any 12-volt negative ground electrical system and be powered through a Federal Signal Power Distribution Center or directly from the vehicle battery.

This compact siren (6.8"W x 3"H x 7.75"D) is packed with standard features, built-in versatility and product reliability that simply can't be matched by similar competitive products. Nine on-board relays are used to deliver 80 amperes of total switching capacity and can control primary, secondary, take down, alley, and auxiliary lighting circuits. The PA640 siren has two built-in flasher circuits available, provides advanced "dynamic" short circuit protection and allows the installer to easily change switch functions via internal programming.

Wail, Yelp, Priority or Hi-Lo, Manual Peak-and-Hold, and Air Horn, are all standard tones and can be enabled by a heavy-duty five position rotary switch. There are six backlighted rubber membrane auxiliary relay push button switches, a user-friendly four position high current slide switch, separate push buttons for Air Horn and Manual activation, and a rotary PA/Volume control knob – all smartly located on the face-plate. Park-Siren Deactivation is built into the PA640 PC board. It is automatically activated once the vehicle transmission is shifted into Park. The Horn Ring Transfer (HRT) function allows siren and light step-through control and delivers effective traffic management, using the steering wheel horn ring.

## > Features

- Full-featured electronic siren with light control, PA and Air Horn.
- 100-watt output and 80-amp total switching capacity.
- Advanced crystal controlled microprocessor technology.
- Meets Class A and SAE J1849 sound output requirements.
- Internally programmable tones, switch functions and relay outputs.
- Reversed polarity and "dynamic" short circuit protection.
- Horn Ring Transfer (HRT) and two built-in flashers included.

## > Approvals

- SAE J1849/ July '02 compliant
- CCR (CAC) Title 13 Class A

## > How to Order

### Versatile

Unmatched versatility is achieved through internal programming built into the PA640 siren. Any of the six auxiliary push buttons can be changed from a standard on/off switch into a momentary, flasher, or eight second timer. In addition, auxiliary relays, standard tones and even HRT functions can be programmed to operate off of any slide switch position desired.

### Reliable

Advanced electronic technology that features the use of crystal-controlled microprocessors dramatically enhances the reliability of the PA640 siren. This type of microprocessor continuously monitors current flow between the output transistors and the speaker. This "dynamic" style of short circuit protection between the output transistors and the amplifier delivers a quicker, more effective way to protect your siren warning system.

### Selector Switch Functions

- RADIO** Incoming radio messages are amplified by the siren and rebroadcast over the outside speaker.
- MANUAL** Allows siren operation via the Air Horn or Manual push button switches or through the vehicle horn ring if the HRT function is enabled.
- WAIL** Produces continuous "wailing" sound.
- YELP** Produces a continuous and rapid "warbled" tone.
- PRIORITY** Produces a continuous and extremely rapid "warbled" tone.

### Vehicle Horn Ring Switch

#### Horn Ring Transfer (HRT)

(Horn Ring and siren tones are factory set to be dependent on the slide switch position.)

**Slide switch positions – Off, 1 and 2** HRT is not transferred (Horn Ring operates the vehicle horn).

**Slide Switch position 3** – HRT is transferred and will scroll through tones starting with tone chosen on selector switch.

### Specify the model

**Model 640000** Siren, 100-watt, light control, 80-amp switch capacity, internally programmable, standard tones and HRT (Horn Ring Transfer)

Specifications	
Input Voltage	11 VDC to 16 VDC
Standby Current	0mA (ignition off) 150mA (ignition on)
Operating Current	9.25A (@ 13.6V with 11-ohm load, amplifier in wail)
Operating Temperature	-30° C to +65° C
Voltage Output (approx.)	64V peak-to-peak
Total Current Rating for Relays	80A Combined Total – all relays
Slide Switch Outputs	Mode 1 (30A) Mode 2 (30A) Mode 3 (30A), (40A combined total)
Push button Switch Outputs	20A each
Physical Dimensions	
Width	6.8 in (17.3 cm)
Height	3.0 in (7.6 cm)
Depth	7.75 in (19.7 cm)
Ship Weight	
	6 lbs (2.7 kg)

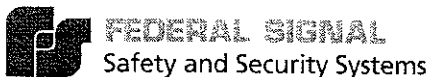

2645 Federal Signal Drive University Park, IL 60466-3195  
Tel.: (800) 264-3578 • Fax: (800) 682-8022  
www.fedsig.com

Warning: Sirens and Speakers may produce LOUD sounds necessary to request the right-of-way. Sirens and Speakers may cause hearing damage. Wear hearing protection.

# SMARTSIREN®

## ELECTRONIC SIREN AND LIGHT CONTROL SYSTEM

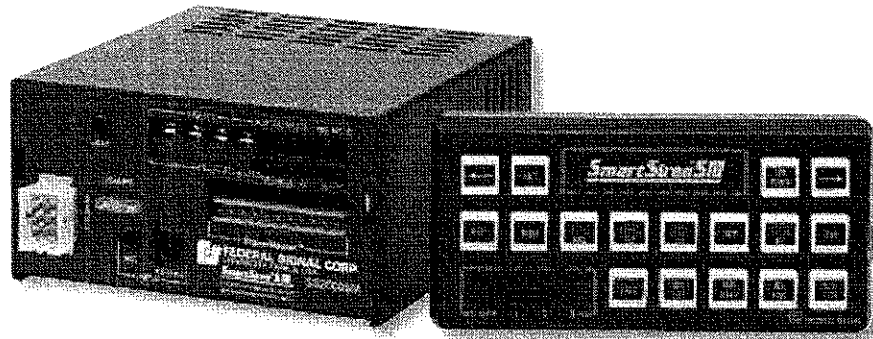

Federal Signal's SmartSiren® electronic siren and light control is the most technologically advanced unit available. Using microprocessors and state-of-the-art design, SmartSiren systems pack all the features you need into an ultra-compact package!

The SmartSiren system consists of a control head and a separate amplifier/relay unit. The control head features a four-position slide-switch, for quick activation of warning functions, and up to seventeen push-buttons. Model SS2000SM-SD adds four buttons for control of a SignalMaster™ directional light. Both models provide for activation of six auxiliary circuits.

SmartSiren units offer the standard siren tones (Wail, Yelp, Hi-Lo, Priority, Air Horn and Manual) and several advanced features, such as horn ring transfer, radio rebroadcast, and PA. There is also provision for the installation of a user-supplied switch to activate lights and siren in pursuit mode.

To use the PA feature, a separate microphone, model MNCT-SB, must be purchased. If the amplifier is mounted remotely, an extension cable, model RMK, is also required.

The SmartSiren system can drive 58-watt, 100-watt, and 200-watt speakers. For control of lights and auxiliary functions, eight relay outputs are available: one 40-amp, two 20-amp, and five 10-amp outputs.

Additionally, model SS2000SM-SD enables control of seven distinct patterns (three directional and four flashing warning) on six-lamp or eight-lamp SignalMaster units. An LED display on the control head flashes in the same pattern as the one currently selected.

For added versatility, the SmartSiren system can be configured at the point of installation. Users can select desired functions and program them through the control head.

Installing the SmartSiren system is easy. The amplifier/relay unit can be remotely located and connected to the control head via a 25-foot wire with telephone-style connectors. The supplied mounting bracket allows the assembly to be located in a variety of positions.

The SmartSiren control head is "Air Bag Wise." When installed properly, it won't interfere with deploying air bags. For safe equipment mounting zones inside the vehicle, consult the manufacturer's guidelines.

### > Features

- Electronic siren and light control combined.
- Functions programmable at the point of installation.
- Power versatility – 58, 100 and 200 watts.
- "Air Bag Wise" – 1-inch thick control head.
- Easy action rubberized push-buttons.
- Buttons backlit for easy nighttime viewing.
- Optional SignalMaster™ directional light control (SS2000SM).
- Easy installation with supplied connectors.

### > Approvals

- Meets SAE J1849 and CCR (CAC) Title 13, article 8 requirements for sound when coupled with any Federal Signal, SAE and CCR approved speaker.

## > How to Order

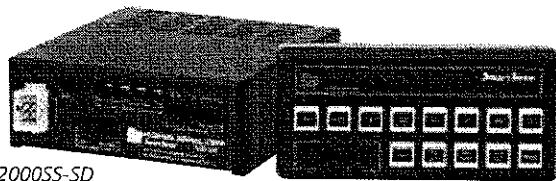

SS2000SS-SD

### SmartSiren Features

- Slide-switch positions can activate one or more light and siren functions
- Push-buttons can be specified to be on/off or momentary
- Eight-second timer can be programmed to any switch function
- Audible "chirp" feature can remind user of the active status of the siren
- Supplied function labels identify switches and are easily replaced

### SS2000SS-SD Features

- Wail, Yelp, Hi-Lo, Air Horn, Manual, Priority, and horn ring transfer
- Program mode can be disabled to prevent unauthorized reprogramming
- Siren tones and light functions can be configured independently of each other
- "Power Up" siren tone may be selected (Wail, Yelp, Hi-Lo, or Priority)
- Each slide-switch position can be configured to operate any combination of eight relays, PA, horn ring transfer, and siren enable
- Any button on the siren row, except STBY, can be enabled or disabled

### SS2000SM-SD Features

- Same as SS2000SS-SD plus:
- Control of up to seven distinct SignalMaster patterns
- Configuration of the slide-switch positions to operate any combination of eight relays, PA, horn ring transfer, siren enable, and any of the four SignalMaster warning patterns

### Select Model

- SS2000SS-SD** Electronic siren and light control system
- SS2000SM-SD** Electronic siren and light control system with SignalMaster control

### Order Accessories (if necessary)

- MNCT-SB** Noise-cancelling microphone
- RMK** Extension cable for microphone
- AS124** 100-watt speaker (model 750501)
- MS100** DynaMax 100-watt speaker
- UPKM-3** Park siren deactivator module

Specifications	
Input Voltage	11-16 VDC
Standby Current	0.5A
Operating Temperature	-30°C to +65° C
Frequency Range	700 to 1500 Hz (nominal)
Nominal Cycle Rate	Wail - 12 cycles/min.
	Yelp - 180 cycles/min.
	Hi-Lo - 60 cycles/min.
Voltage Output	62-66 volts peak-to-peak
Audio Response	300-3000 Hz +/- 3dB
Audio Power	45W in PA mode
Input Impedance (PA)	4000 ohms (nominal)
Physical Specifications (Amplifier)	
Length	6.3 in (15.9 cm)
Width	6.4 in (16.2 cm)
Height	2.3 in (5.9 cm)
Ship Weight	6.0 lbs (2.7 kg)
Physical Specifications (Control Head)	
Length	6.8 in (17.2 cm)
Width	1.3 in (3.3 cm)
Height	3.1 in (7.9 cm)
Shipping Weight	1.0 lbs (0.5 kg)



2645 Federal Signal Drive University Park IL 60466-3195  
 Tel : (800) 264-3578 • Fax: (800) 682-8022  
 www.fedsig.com

Warning Sirens and Speakers may produce ECUID sounds necessary to request the right of way. Sirens and Speakers may cause hearing damage. Hearing protection.

SmartSiren, SignalMaster and DynaMax are trademarks of Federal Signal Corporation

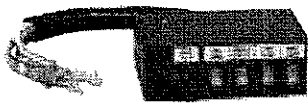

SW400SS



SW300-012

Three-Toggle Switch Control  
(SW30)Three-Rocker Switch Control  
(670132)

210633

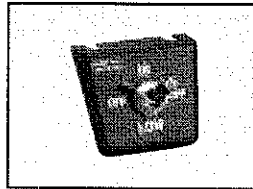

Switch kit (210390)

Two-Rocker Switch Control  
(SW2)

## SWITCHES

Federal Signal offers a complete line of switches for any warning equipment package, from a single light or backup alarm to strobe systems and warning light combinations.

### “SW” SERIES SWITCH CONTROLS

SW switch controls are full-featured to provide complete control for larger warning systems. The SW400SS offers switching capacity for up to seven separate lighting or auxiliary functions. This model features a three-position slide-switch that can activate a single device or multiple devices quickly. Positions 1 and 3 on the slide-switch have a 20-amp relay and are fused at 20-amperes. Position 2 has a 40-amp relay and a self-resetting 40-amp circuit breaker. The SW400SS also has four rocker switches, each with 20-amp capacity.

The SW300 and SW200 switch controls use single-pole/single-throw rocker switches for activation of equipment. The SW300 has six rocker switches, and the SW200 has four. On both models, the first switch has 40-amp switching capability, and the remaining switches provide 15-amp capability.

Three-switch and two-switch controls are available for users with fewer than four functions. The SW30 is a three-toggle switch control panel. The 670132 is a three-rocker switch control panel and the SW2 is a two-rocker switch control panel. All models feature switches that are rated for 15 amperes. The panels are designed to mount flush to the vehicle dashboard.

### TOGGLE SWITCHES

For simple warning systems, toggle switches can provide an economical solution.

- Standard toggle switches are single-pole/single-throw, 12VDC, and rated for 10 amperes.
- Three-position toggle switch is rated for 15 amperes at 30VDC.
- Chrome toggle switch is a two-position, one-inch bat type chrome on metal lever that is single-pole/single-throw and rated for 35 amperes.
- Switch kit is a three-position switch and panel kit that allows for multiple light controls and is isolated for joint use of light.

### EFFECTIVE

- Variety of models available to control virtually any light function.
- Backlighting gives easy nighttime visibility.
- Easy to install.

### RELIABLE

- Self-resetting circuit breakers.
- Blade-type fuses for ease of replacement.

### DURABLE

- Fused circuitry.

### APPLICATIONS

- All applications that require light function controls.

## ORDERING INFORMATION

### “SW” SWITCH CONTROL MODELS

SW400SS	SW Switch Panel with slide-switch and four rocker switches
SW300-012	SW Switch Panel with six rocker switches
SW200-012	SW Switch Panel with four rocker switches
SW30	SW Switch Panel with three toggle switches
670132	SW Switch Panel with three rocker switches
SW2	SW Switch Panel with two rocker switches

### “SW” SWITCH CONTROL OPTIONS

SW-BK	Mount bracket for SW400SS and SW300
SW-BK1	Mount bracket for SW200

### “SW” SWITCH CONTROL REPLACEMENT PARTS

671512	Rocker switch, 15-amp
671522	Toggle switch
Z122287	Slide-switch

### TOGGLE SWITCH MODELS

210620	Toggle switch, black
200564	Three-position toggle switch
210633	Chrome on metal toggle switch
210390	Switch kit with three-position toggle switch

### TOGGLE SWITCH OPTIONS

210624	Single-hole switch panel for use with 1/2-inch diameter toggle switches
--------	---

## SPECIFICATIONS

Model	L. x W. x H.		Ship. Weight	
	in	mm	lbs	kg
SW400SS	4.9 x 6.1 x 2.2	125 x 155 x 56	3.0	1.3
SW300	4.9 x 6.1 x 2.2	125 x 155 x 56	3.0	1.3
SW200	4.9 x 4.75 x 2.2	125 x 121 x 56	2.5	1.1

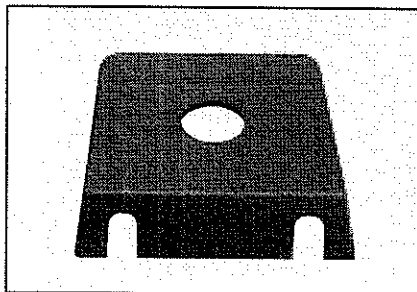

210624

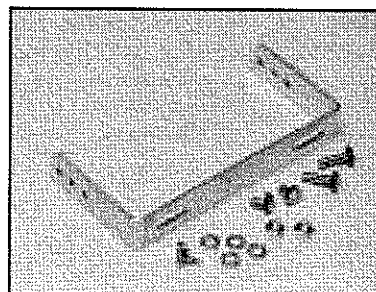

SW-BK

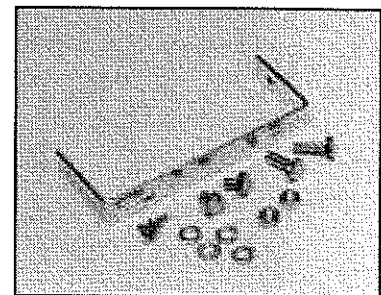

SW-BK1

# 650 SERIES SIREN

## REMOTE MICROPHONE-CONTROLLED SIREN

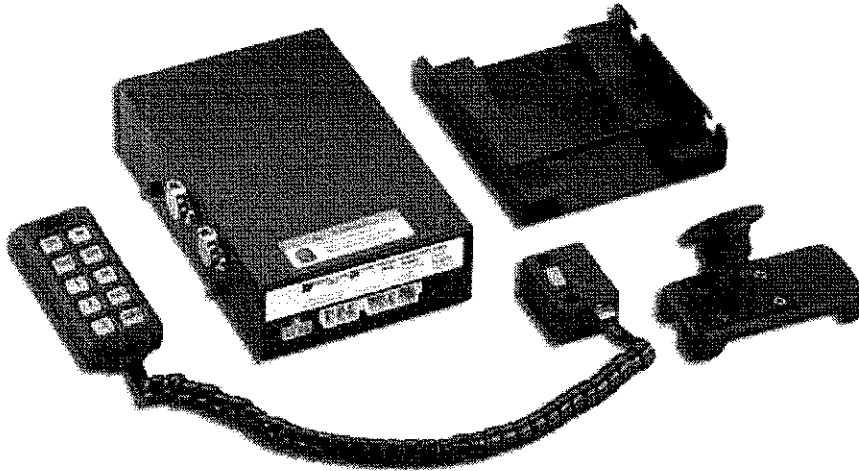

Federal Signal's innovative 650 series siren allows for all sound and light functions to be enabled by rubberized push buttons located on the unit's compact (4.5" L x 2" W x 1" H) and easy to use microphone control head. The advanced microprocessor based amplifier exemplifies Federal Signal's commitment to remain today's unmatched leader in the field of siren technology.

### Compact Microphone Controller

All siren and light functions are located on the 650 series microphone. Ten rubberized push buttons control three progressive "slide switch-like" positions, on/off, PA, Air Horn, Peak-and-Hold, tone switching, and up to 30-amps of additional auxiliary power. The microphone controller "snaps" into a small plastic remote junction box where PA volume and a secondary on-off switch are located, then runs directly to the 650 series amplifier. Both of these connections are plug-and-play via eight conductor telephone jacks. An innovative microphone holder that can rotate and pivot to almost any angle allows for a wide variety of installation possibilities.

### Advanced Amplifier Design

The 650 series remote siren provides 100-watt speaker output and can operate from any 12-volt negative ground vehicle electrical system. It is short circuit protected and can be powered through an installed power distribution center (PDC), or directly from the vehicle's battery. Reliability and efficiency is maximized by the use of advanced microprocessor based technology. The 650 series amplifier comes equipped with eight 10 amp light or auxiliary relay connections, is horn ring control ready, and has its own bracket mount to allow for quick and easy removal or replacement. Also provided is a 16.5' wire harness and all necessary hardware.

### > Features

- Microphone controlled siren amplifier and light functions
- Progressive 3-position "slide switch like" push button control
- Backlit/rubberized microphone control head
- Microprocessor based amplifier with plug-and-play connections
- Eight 10-amp light and Aux relay positions
- 100-watt output – Wail, Priority, Air Horn, Manual Peak, and Hold tones.
- Versatile microphone and amplifier mounting brackets
- Remote on/off switch box with built-in PA volume control
- Horn ring transfer
- Installs quickly and is easy to operate

### > Approvals

- Meets SAE J1849 requirements for sound output



## > How to Order

### Specify Model

- 650001** 100-watt, microphone push-button controlled, full featured, wail/no wail tone activation, (8) 10-amp relay outputs
- 650003** 100-watt, microphone push-button controlled, full featured, wail-to-priority tone activation, (8) 10-amp relay outputs

Specifications	
Input Voltage	11 VDC to 15 VDC
Polarity	Negative Ground Only
Operating Temp.	-30° to +65°C
Standby Current	<0.22 amperes
Separating Current (no lamps on)	8A (nominal) (13.6 V battery, 11 ohm load)
Frequency Range	725 – 1550 Hz
Voltage Output	62-66 V peak-to-peak
Physical Dimensions	
Amplifier	8.5"L (21.6 cm) x 5.5"W (13.9 cm) x 2"H (5.1 cm) (without base)
Control Head	4.5"L (11.4 cm) x 2"W (5.1 cm) x 1"H (2.5 cm)
Ship Weight	
Siren	6.5 lbs (3.0 kg)
Control Head	0.5 lbs (0.25 kg)

### 10 Push-Button Controller Switch Operation

- OFF** Turns off all enabled tone and light functions
- PA** Allows speech/RRB through vehicle's speaker / overrides all other functions
- MAN** Manual Peak-and-Hold / functions when all other tones are off
- AH** Air Horn
- POS #1** Activates 10-amp relay
- POS #2** Keeps #1 enabled and activates second 10-amp relay (progressive)
- POS #3** Keeps #1 and #2 enabled and activates third 10-amp relay (progressive)
- AUX 1** Scrolls through (2) 10-amp relays
- AUX 2** Activates third AUX 10-amp relay

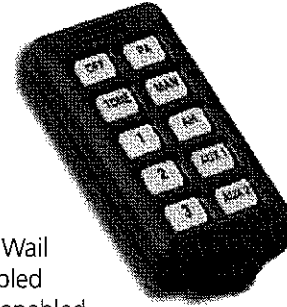

**TONE 650001** – Eliminates Wail tone when #3 is enabled (priority tone can be enabled via HRT)

**650003** – Switches tone between Wail and Priority when #3 is enabled

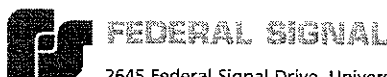

**FEDERAL SIGNAL**

2645 Federal Signal Drive University Park, IL 60466-3195  
Tel.: (800) 264-3578 • Fax: (800) 682-8022  
www.fedsig.com

Warning: Sirens and Speakers may produce LOUD sounds necessary to require the right of way. Sirens and Speakers may cause hearing damage. Wear hearing protection.

# IMPAXX<sup>®</sup> EXTERNAL MOUNT/PERIMETER LIGHTS

## IMPAXX<sup>®</sup>

available in: 

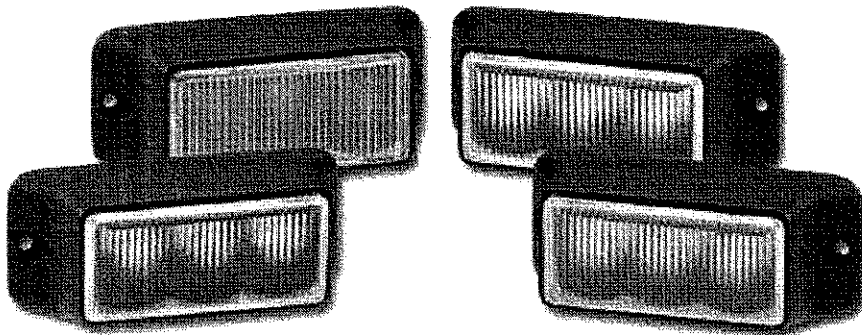

### Highly Effective Warning

IMPAXX light heads combine Solaris<sup>®</sup> reflector technology with the most advanced LEDs for the brightest, most efficient auxiliary, compact light available

IMPAXX can operate independently, synchronize with other IMPAXX, or synchronize with Federal Signal lightheads equipped with the advanced 2-phase wire feature. IMPAXX lightheads are programmed with up to 23 built-in flash patterns. These patterns can be synchronized to flash in the same pattern, flash in a sliding progression or flash in opposite sequence of each other

### Optimized Lighting

IMPAXX light heads are available with either center focused or off axis lensing. The center focused lens directs the LED light forward making them ideal for front or rear vehicle applications. The advanced off-axis lens provides warning light forward and to both sides, allowing for intersection or side vehicle mounting

### Easy Installation

IMPAXX lights come complete with a weatherproof housing, black bezel, and rubber grommet for quick and easy installation. A wide variety of brackets are available for various vehicle types and applications

## > Features

- High output LEDs and Solaris reflective technology
- Compact size allows for a variety of mount locations
- Advanced off-axis and center focused lenses available
- Fully encapsulated weatherproof housing
- Wide variety of synchronized patterns
- Available in Red, Blue, White, Amber, and Green LEDs and lenses
- Variety of mounting brackets available

## > Approvals

- SAE J595, Class 1
- CCR Title 13
- NFPA 1901 Compliant models available
- EMI and RFI approved

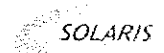

## > How to Order

### Select Model

- IPX300-X** Clear lens – Advanced off-axis light output  
**IPX310-X** Clear lens – Center focused light output  
**IPX302-X** Colored lens – Advanced off-axis light output  
**IPX312-X** Colored lens – Center focused light output

2 = Amber, 3 = Blue, 4 = Red, 5 = White, 6 = Green

### Optional Accessory

**IPXM-1** Chrome bezel, all models (sold separately)

*Note. Black bezel and mounting grommet is included with every model*

Specifications	
Voltage	12.8 VDC
Current Draw	0.7A
Operating Temp.	-30° C to +65° C
Physical Specifications	
Length	3.5 in (8.9 cm)
Width	1.3 in (3.3 cm)
Height	1.5 in (3.8 cm)
Ship Weight	
	0.75 lbs (0.34 kg)

Patterns	
1	Off
2	79 FPM Power Quad
3	150 FPM Single
4	151 FPM Single
5	74 FPM Single
6	75 FPM Single
7	240 FPM Single
8	241 FPM Single
9	240 FPM Double
10	241 FPM Double
11	150 FPM Double
12	151 FPM Double
13	74 FPM Double
14	75 FPM Double
15	150 FPM Triple
16	75 FPM Triple
17	5 Single @ 680 FPM/ 4 Single @ 216 FPM
18	4 Single @ 570 FPM/ 3 Single @ 246 FPM
19	3 Single @ 460 FPM/ 2 Quad @ 75 FPM
20	Progressive Flash
21	4 Single @ 154 FPM/ 2 Quad @ 75 FPM
22	Random Flash
23	Steady Burn



**IPX-TRNK1**  
 IMPAXX/Viper® EXT, pair of inner trunk lid brackets with hardware '02-'08 Ford Crown Victoria Police Interceptor package



**IPX-TRNK2**  
 IMPAXX/Viper EXT, pair of inner trunk lid brackets with hardware '07-'08 Dodge Charger



**IPX-LPV1**  
 IMPAXX/Viper EXT, flat surface license plate mount various vehicles without recessed plate mounting locations



**IPX-LPVX1**  
 IMPAXX/Viper EXT, extended license plate bracket for vehicles with a recessed license plate mount location including but not limited to the '02-'08 Ford Crown Victoria Police Package



**IPX-LPH1**  
 IMPAXX/Viper EXT, generic high side license plate holder with horizontal mount tab on each side fits most vehicles



**IPX-LPF1**  
 IMPAXX only, generic low side license plate holder for horizontal IMPAXX install, most vehicles



**IPX-SW1**  
 IMPAXX/Viper EXT, pair of rear side window mount brackets, '02-'08 Ford Crown Victoria Police Package vehicles



**IPX-PB45H**  
 IMPAXX/Viper EXT, pair of 45-degree slanted push bumper mounts with hardware horizontal light orientation fits most push bumpers



**IPX-PB45V**  
 IMPAXX/Viper EXT, pair of 45-degree slanted push bumper mounts with hardware vertical light orientation fits most push bumpers



**IPX-GRL1**  
 IMPAXX/Viper EXT, (1) grille brackets with hardware vertical mount orientation Ford Crown Victoria Police Package vehicles, '02-'08



**IPX-GRL2**  
 IMPAXX/Viper EXT, (1) grille brackets with hardware horizontal mount orientation Ford Crown Victoria Police Package vehicles, '02-'08

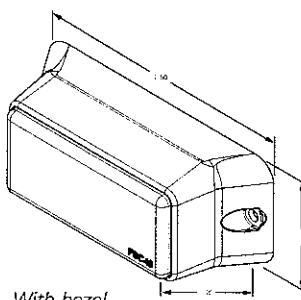

With bezel

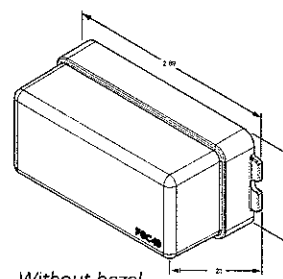

Without bezel

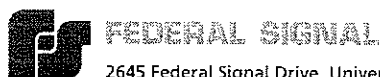

2645 Federal Signal Drive, University Park, IL 60484  
 Tel : (800) 264-3578 • Fax: (800) 682-8022  
 www.fedsig.com

IMPAXX Solaris, and Viper S2 are trademarks of Federal Signal Corporation

©2009 Federal Signal Corporation M4060 I 709

# VIPER® EXT EXTERNAL MOUNT/PERIMETER LIGHTS

available in: 

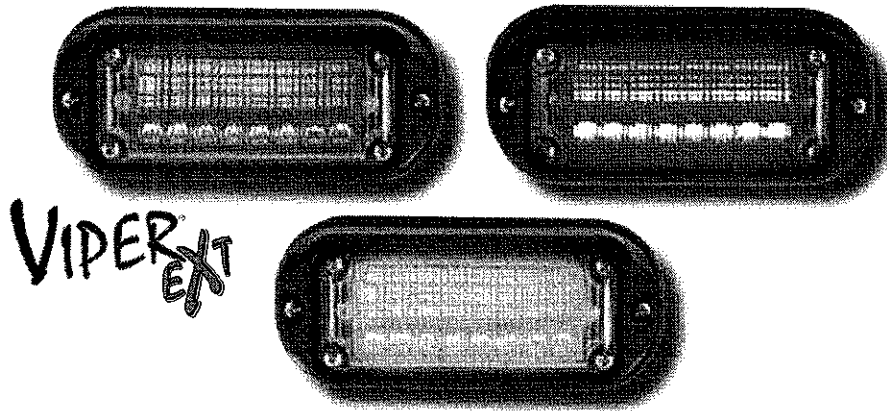

The eight-LED Viper® EXT uses the latest Solaris® reflector and the most effective off-axis lens to deliver the best compact light head that can be installed anywhere inside or outside an emergency vehicle

### Bright and Effective Warning

As a stand alone light, the Viper EXT can flash any of the 23 built-in warning patterns independently Synchronize up to a dozen other Viper EXT lights or with any other Federal Signal light head equipped with our advanced 2-phase wire technology Viper EXT lights are intended to perform as effective secondary warning light signals and can be ordered with either clear or colored lenses

### Reliable and Versatile Installation

Viper EXT lights are designed to be weather resistant and impervious to extreme temperature or climatic conditions The eight high-output LEDs are mounted to a conformal coated PC board that is secured to the cast aluminum housing which pulls away the heat generated by LEDs This assures consistent, long lasting product reliability The lens rests on a fitted gasket and is secured by screws to the housing preventing outside weather conditions from interfering with the performance of the product The Viper EXT comes complete with a 12 inch wire harness, mounting gasket, black polycarbonate bezel and associated hardware There are a variety of vehicle specific brackets currently available for quick and easy installation

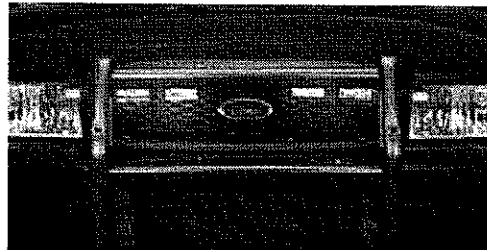

## > Features

- Eight LED lights offered in Amber, Blue, Green, Red, and White
- High-output Solaris LED reflector technology.
- Wide angle lens for unsurpassed off-axis warning capability
- Clear or colored lens with black bezel included; chrome bezel is also available
- Fully encapsulated water resistant housing
- Large library of warning patterns and configurations
- Advanced two-phase pattern synchronization technology
- Wide variety of mounting brackets available
- Extremely low amperage draw

## > Approvals

- SAE J595, Class 1
- CCR Title 13
- NFPA 1901 compliant models available

## > How to Order

### SELECT MODEL

#### Clear Lens

**VPX800-**(color) (8) LEDs, clear lens, off-axis

#### Color Lens

**VPX802-** (color) (8) LEDs, clear lens, off-axis

2 = Amber, 3 = Blue, 4 = Red, 5 = White, 6 = Green

Example: IPX302-3 = IMPAXX light, 3 Blue high output LEDs, blue advanced off-axis lens, black bezel and mounting grommet

### Accessory and Kit

**VPXM-1** Chrome bezel, fits all models

Specifications	
Voltage	12.8 VDC
Current Draw	1.5A
Operating Temp	-30°C to +65°C
Ship Weight	
	1.0 lb (0.45 kg)
Physical Specifications (L x H x W)	
Without Bezel	4.5 in x 1.89 in x 1.5 in (11.4 cm x 4.8 cm x 3.8 cm)
With Bezel	5.7 in x 2.38 in x 1.5 in (14.5 cm x 6.0 cm x 3.8 cm)

Flash Pattern	Description	Flash Pattern	Description
1	Null (off)	14	75 FPM Double
2	79 FPM Power Quad*	15	150 FPM Triple
3	150 FPM Single	16	75 FPM Triple
4	151 FPM Single	17	5 Single @ 680 FPM 4 Single @ 216 FPM
5	74 FPM Single*	18	4 Single @ 570 FPM 3 Single @ 246 FPM
6	75 FPM Single*	19	3 Single @ 460 FPM 2 Quad @ 75 FPM
7	240 FPM Single	20	Progressive (flashes start slow and increase in speed)
8	241 FPM Single	21	4 Single @ 154 FPM 2 Quad @ 75 FPM
9	240 FPM Double	22	Random
10	241 FPM Double	23	3 quick flashes, then stays in Steady Burn
11	150 FPM Double	24	FedPulse 75
12	151 FPM Double	25	Steady Burn
13	74 FPM Double		

\*Conforms to CCR Title 13

Note: Single Double and Quad refer to the number of flashing intervals

### Viper EXT Brackets (optional)

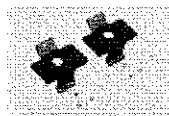

#### IPX-TRNK1

IMPAXX/Viper® EXT, pair of inner trunk lid brackets with hardware '02-'08 Ford Crown Victoria Police Interceptor package



#### IPX-TRNK2

IMPAXX/Viper EXT, pair of inner trunk lid brackets with hardware '07-'08 Dodge Charger



#### IPX-LPV1

IMPAXX/Viper EXT, flat surface license plate mount, various vehicles without recessed plate mounting locations



#### IPX-LPVX1

IMPAXX/Viper EXT, extended license plate bracket for vehicles with a recessed license plate mount location including but not limited to the '02-'08 Ford Crown Victoria Police Package

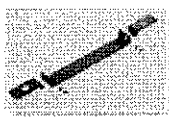

#### IPX-LPH1

IMPAXX/Viper EXT, generic high side license plate holder with horizontal mount tab on each side fits most vehicles



#### IPX-SW1

IMPAXX/Viper EXT, pair of rear side window mount brackets, '02-'08 Ford Crown Victoria Police Package vehicles



#### IPX-PB45H

IMPAXX/Viper EXT, pair of 45-degree slanted push bumper mounts with hardware horizontal light orientation fits most push bumpers



#### IPX-PB45V

IMPAXX/Viper EXT, pair of 45-degree slanted push bumper mounts with hardware vertical light orientation fits most push bumpers



#### IPX-GRL1

IMPAXX/Viper EXT, (1) grille brackets with hardware vertical mount orientation Ford Crown Victoria Police Package vehicles, '02-'08



#### IPX-GRL2

IMPAXX/Viper EXT, (1) grille brackets with hardware horizontal mount orientation Ford Crown Victoria Police Package vehicles, '02-'08

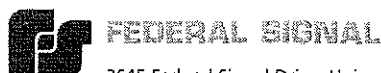
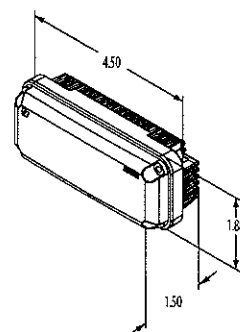
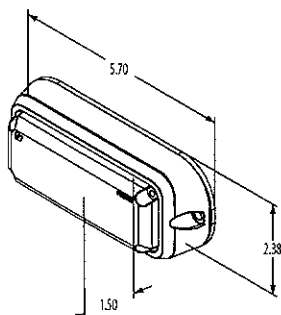

2645 Federal Signal Drive, University Park IL 60466-3195  
Tel.: (800) 264-3578 • Fax: (800) 682-8022  
www.fedsig.com

Viper EXT and Solans are trademarks of Federal Signal Corporation

©2009 Federal Signal Corporation M3531 | 309



## Warranty

### LIMITED WARRANTY

Federal Signal Corporation, Emergency Products, (Federal) warrants each new product, except speakers, to be free from defects in material and workmanship, under normal use and service, for a period of (3) years on parts replacement from the date of manufacture stamped on the product and (1) year on labor from the date of delivery to the first user-purchaser except for noted products. Speakers are warranted for a period of (2) years on parts replacement from the date of manufacture stamped on the product and (1) year on labor from the date of delivery to the first user-purchaser. The following products are warranted for (5) years on parts replacement from the date of manufacture stamped on the product and (1) year on labor from the date of delivery to the first user-purchaser: "Light Emitting Diode" (LED) products (Signaltech products not included), "Ricochet" strobe power supplies, "Unitrol" brand products, rotating light assemblies from all lightbars, all rotating beacons and mini-lightbars (Sentinel not included), all Phase II strobe beacon models, all 901 and 951 strobe beacon models, all 651 and 851 strobe beacon models, all US5, US6, and US7 UltraStar strobe beacon models, and all Arctic strobe beacon models. Strobe flashtubes are warranted for (1) one year parts replacement from the date of delivery of the first user-purchase. During this warranty period, the obligation of Federal is limited to repairing or replacing, as Federal may elect, any part or parts of such product which after examination by Federal, is found to be defective as the result of a defect in material and/or workmanship. Federal will provide warranty for any unit which is delivered, transported prepaid, to the Federal factory or designated authorized warranty service center for examination and such examination reveals a defect in material and/or workmanship. This warranty does not cover travel expenses, the cost of specialized equipment for gaining access to the product, or labor charges for removal and re-installation of the product. Domes & lenses, lamps or batteries are not covered under warranty. This warranty does not extend to any unit which has subjected to abuse, misuse, improper installation or which has been inadequately maintained, nor damage resulting from incompatible chemicals or cleaning material, nor to units which have problems relating to service or modification at any facility other than the Federal factory or authorized service centers. This warranty is in lieu of all other warranties, express or implied, including warranties of merchantability and fitness for a particular purpose.

[\[print\]](#)

entire contents copyright © 2004-2009 Federal Signal | [Privacy Policy](#) | [Terms of Use](#) | [Site Map](#)

# ILS INTERNAL LIGHT SYSTEM

## > Features

available in: 

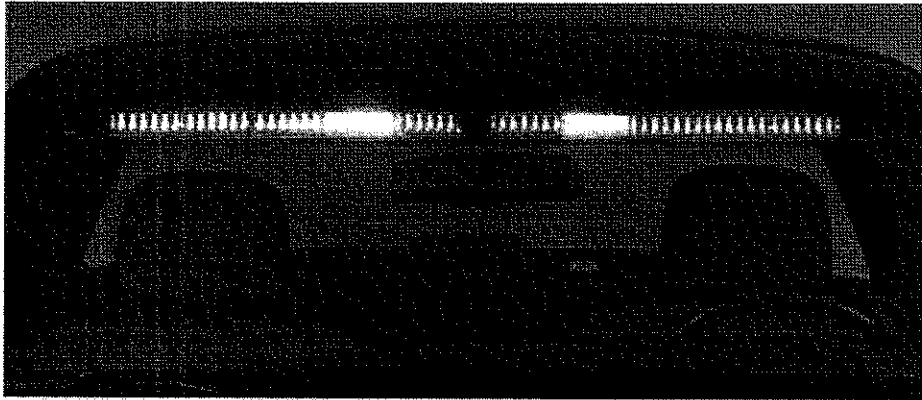

Lightbar performance for low profile vehicles

26 selectable flash patterns and three modes of operation

Solaris LED assemblies are available in red, amber, blue, white, and green

LED takedowns available

Five-year warranty

### Advanced Engineering

Federal Signal ILS systems feature ROC (Reliable Onboard Circuitry) and Solaris LED reflector technology. ROC eliminates approximately 85% of the potential failure points found in traditional lighting assemblies. SOLARIS reflectors incorporate off-set reflector surfaces to reach the highest optical efficiency.

ILS systems also utilize advanced microprocessor controller provides three modes of operation and a selection of new pre-programmed flash patterns and two test patterns. While RS485 bus connection simplifies installation with only power, ground, and snap-in RJ-style connections.

### Front Headliner Models

Select model ILSFF for low profile effective warning for the front of the vehicle. The system provides the highest level of flash activity while LED takedowns provide added effectiveness. From the inside the vehicle, the SOLARIS ILS blends right into the headliner to complement the existing interior of the vehicle.

### Rear Headliner and Deck Models

For bright emergency warning to the rear of the vehicle, select the Solaris ILS Rear Deck models. These can operate as standard emergency warning or SignalMaster directional light. The Rear Deck models were specifically designed to pick up the radius of the rear window to maximize off axis warning.



## > How to Order

### Customize Models

Choose one of the popular models below, customize your own with our online configurator or contact a local Federal Signal representative or distributor.

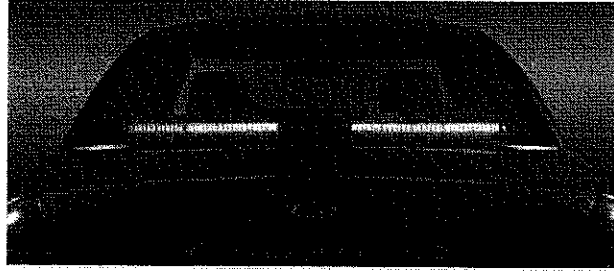

### Solaris ILS Front Headliner

**ILSFF-XXXXX** (10) 6-LED reflectors

### Solaris ILS Rear Deck

**ILSFD-XXXXX** (10) 6-LED reflectors

	ILS Crown Victoria	ILS Chevrolet Impala	ILS Dodge Charger	ILSFD Crown Victoria	ILSFD Chevrolet Impala	ILSFD Dodge Charger
<b>Specifications</b>						
Current Draw	TBD					
Input Voltage	11 VDC - 12 VDC					
Standby Current	Less than 10 mA					
<b>Physical Dimensions</b>						
Height	1.70 in (4.30 cm)	1.70 in (4.30 cm)	1.70 in (4.30 cm)	1.95 in (5.00 cm)	1.75 in (4.40 cm)	1.5 in (3.80 cm)
Length	41.66 in (105.80 cm)	39.80 in (101.10 cm)	40.74 in (103.50 cm)	47.72 in (121.20 cm)	39.58 in (100.50 cm)	39.49 in (100.30 cm)
Depth	6.60 in (16.80 cm)	8.49 in (21.6 cm)	6.54 (16.60 cm)	6.27 in (15.90 cm)	6.36 in (16.20 cm)	5.66 in (14.40 cm)
<b>Ship Weight</b>						
	8 lbs (3.3 kg)					

## Popular Solaris.. ILS Models

### Front Headliner Models



Crown Vic - ILSFF-00003  
Charger - ILSFF-00036  
Impala - ILSFF-00040  
Tahoe - ILSFF-00061  
F-150 - ILSFF-00062



Crown Vic - ILSFF-00006  
Charger - ILSFF-00033  
Impala - ILSFF-00038  
Tahoe - ILSFF - 00059  
F-150 - ILSFF-00058

### Rear Deck Models



Crown Vic - ILSFD-00021  
Charger - ILSFD-00083  
Impala - ILSFD-00057



Crown Vic - ILSFD-00091  
Charger - ILSFF-00102  
Impala - ILSFD-00101

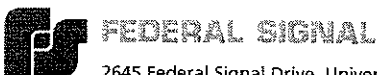

FEDERAL SIGNAL  
2645 Federal Signal Drive University Park, IL 60484  
Tel : (800) 264-3578 • Fax: (800) 682-8022  
www.fedsig.com

Reliable Onboard Circuitry. Solaris and SignalMaster  
are trademarks of Federal Signal Corporation



# DYNAMAX™ SPEAKERS

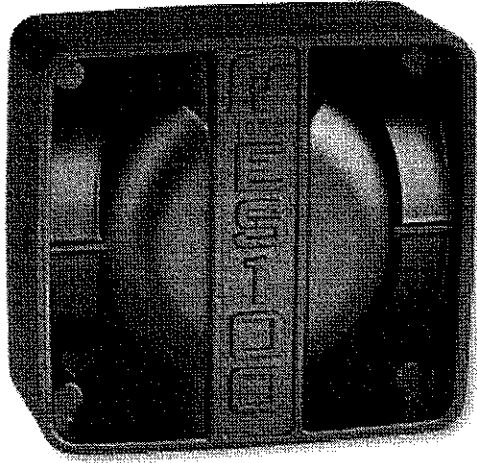

## Sleek Design Meets High-Performance

The Dynamax, ES100, speaker features the Federal Signal Neo driver for increased performance and reliability. The larger diaphragm of the ES100 allows the speaker to capture lower frequency ranges for a more robust sound.

The ES100 is a 100-watt speaker designed to withstand the toughest conditions. The Dynamax is made of black corrosion resistant aluminum housing and is fully encapsulated.

Designed for versatility, the ES100 mounts easily into grille, flush between the bumper and hose tray of large apparatus and to most vehicle bumpers. A variety of mounts and brackets are also available to make installation as simple as possible.

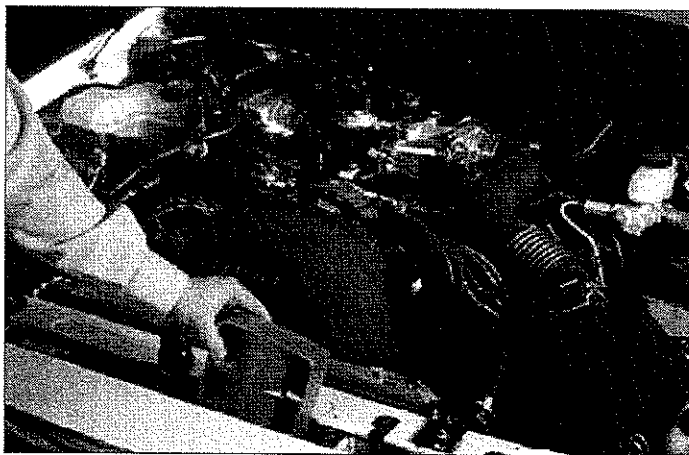

*DynaMax speakers fit easily behind the grille.*

## > Features

- Neo driver
- 100-watt power
- Slim and lightweight
- Easy to install and maintain
- Can be used on large apparatus, ambulances, law enforcement vehicles, and command fleet
- Durable and reliable

## > Approval

- SAE and CCR specifications when paired with Class A Federal Signal amplifier and electronic siren

## > How to Order

### Select Model

**ES100** Speaker, 100-watt, high output compact

### Brackets

**ESB-U** Universal bail bracket, all vehicles  
**ESB-V97** Ford Crown Vic Interceptor, '97  
**ESB-V01** Ford Crown Vic, Interceptor, '98-'01  
**ESB-V08** Ford Crown Vic, Interceptor, '02-'08  
**ESB-TAH02** Chevrolet Tahoe, '02 & earlier  
**ESB-TAH05** Chevrolet Tahoe, '03-'05 Police only  
**ESB-TAH08** Chevrolet Tahoe, '03-'08  
**ESB-IMP02** Chevrolet, Impala, '00-'02 police, '04 civilian  
**ESB-IMP08** Chevrolet, Impala, '06-'08  
**ESB-CRG07** Dodge Charger, '07  
**ESB-HMR** Hummer H3, '07  
**ESB-EXP07** Ford Explorer, '07  
**ESB-EXP05** Ford Explorer/Expedition, '95-'05  
**ESBMT-SB** Bumper/surface mount bracket  
**ESFMT** Recess mount, polished trim ring  
**ESFMT-EF** Recess mount, stainless steel "Electric F" grille

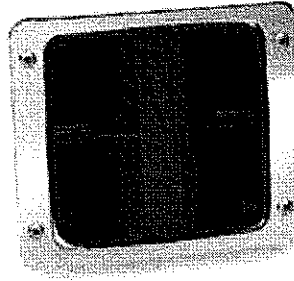

Flush mount, ESFMT

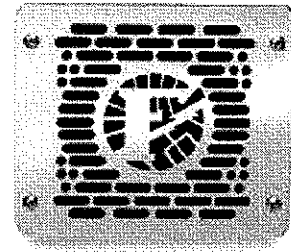

Flush mount with grille, ESMFT-EF

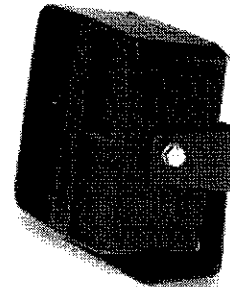

Bumper mount, ESBMT

Factory Set Specifications	
Input Voltage	32VRMS
Power	100W
Sound Output	SAE J1849 CCR Title 13
Impedance	11 ohms
Physical Dimensions	
Height	5.5 in (14 cm)
Width	5.9 in (15 cm)
Depth	2.7 in (6.9 cm)
Ship Weight	
	5.5 lbs (2.5 kg)

### Dimensional Diagrams

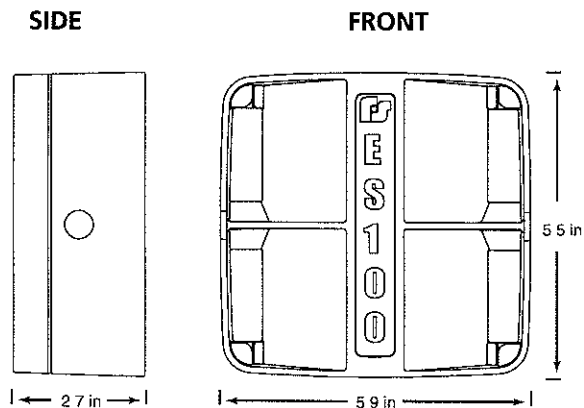

2645 Federal Signal Drive, University Park, IL 60466-3195  
 Tel.: (800) 264-3578 • Fax: (800) 682-8022  
 www.fedsig.com

Warning: Sirens and speaker only produce 100dB sound is necessary to request the right priority. Sirens and speakers may cause hearing damage. Wear hearing protection.

DynaMax is a trademark of Federal Signal Corporation

©2009 Federal Signal Corporation M2516 I 609