



State of West Virginia  
 Department of Administration  
 Purchasing Division  
 2019 Washington Street East  
 Post Office Box 50130  
 Charleston, WV 25305-0130

**Request for  
 Quotation**

RFQ NUMBER  
**DNR210130**

PAGE  
**1**

ADDRESS CORRESPONDENCE TO ATTENTION OF  
**FRANK WHITTAKER  
 304-558-2316**

RFQ COPY  
 FEIN: 04-3716862  
 TYPE NAME/ADDRESS HERE

FEIN: 04-3716862

Alpha Contracting, LLC  
 198 Prosperity Road  
 Beckley, WV 25801  
 304-252-4339

DIVISION OF NATURAL RESOURCES  
 VARIOUS LOCALES AS INDICATED  
 BY ORDER

DATE PRINTED	TERMS OF SALE	SHIP VIA	FOB	FREIGHT TERMS
03/17/2010				

BID OPENING DATE: **04/14/2010** BID OPENING TIME **01:30PM**

LINE	QUANTITY	UQP	QNT NO	ITEM NUMBER	UNIT PRICE	AMOUNT
0001	1	LS		968-42		
KEY CARD LOCK SYSTEM WITH INSTALLATION						
0002		EA		968-42		
GENERAL CONSTRUCTION						
<p>THE WEST VIRGINIA PURCHASING DIVISION, FOR THE AGENCY, THE WEST VIRGINIA DIVISION OF NATURAL RESOURCES, IS SOLICITING BIDS FOR KEY CARD DOOR LOCK SYSTEMS FOR FOUR WV STATE PARK LODGES, PER THE ATTACHED SPECIFICATIONS.</p> <p>ALL TECHNICAL QUESTIONS MUST BE SUBMITTED IN WRITING TO FRANK WHITTAKER IN THE PURCHASING DIVISION VIA EMAIL AT FRANK.M.WHITTAKER@WV.GOV OR VIA FAX AT 304-558-4115. DEADLINE FOR TECHNICAL QUESTIONS IS 03/29/2010 AT 3:00 PM. ALL TECHNICAL QUESTIONS WILL BE ADDRESSED BY ADDENDUM AFTER THE DEADLINE.</p> <p>EXHIBIT 5</p> <p>WEST VIRGINIA CODE 21-1D-5 PROVIDES THAT: ANY SOLICITATION FOR A PUBLIC IMPROVEMENT CONSTRUCTION CONTRACT REQUIRES EACH VENDOR THAT SUBMITS A BID FOR THE WORK TO SUBMIT AT THE SAME TIME AN AFFIDAVIT OF COMPLIANCE WITH THE BID. THE ENCLOSED DRUG-FREE WORKPLACE AFFIDAVIT MUST BE SIGNED AND SUBMITTED WITH THE BID AS EVIDENCE</p>						

RECEIVED  
 2010 APR 22 PM 12:33  
 WV PURCHASING DIVISION

SIGNATURE <i>[Signature]</i>			TELEPHONE <b>304-252-4339</b>		DATE <b>4/21/10</b>
TITLE <b>C.O.O.</b>		FEIN <b>04-3716862</b>		ADDRESS CHANGES TO BE NOTED ABOVE	

WHEN RESPONDING TO RFQ, INSERT NAME AND ADDRESS IN SPACE ABOVE LABELED 'VENDOR'



State of West Virginia  
 Department of Administration  
 Purchasing Division  
 2019 Washington Street East  
 Post Office Box 50130  
 Charleston, WV 25305-0130

**Request for  
 Quotation**

RFQ NUMBER  
**DNR210130**

PAGE  
**1**

ADDRESS CORRESPONDENCE TO ATTENTION OF  
**FRANK WHITTAKER  
 304-558-2316**

VENDOR

RFQ 04BY16862  
 TYPE NAME ADDRESS HERE  
 FEIN: 04-3716862

**Alpha Contracting, LLC**  
 198 Prosperity Road  
 Beckley, WV 25801  
 304-252-4339

SHIP TO

**DIVISION OF NATURAL RESOURCES  
 VARIOUS LOCALES AS INDICATED  
 BY ORDER**

DATE PRINTED	TERMS OF SALE	SHIP VIA	FOB	FREIGHT TERMS
04/09/2010				

BID OPENING DATE: **04/22/2010** BID OPENING TIME **01:30PM**

LINE	QUANTITY	UOP	CAT NO	ITEM NUMBER	UNIT PRICE	AMOUNT
***** ADDENDUM NO. 2 *****						
THIS ADDENDUM IS ISSUED TO:						
1) EXTEND THE BID OPENING DATE TO 04/22/2010 AT 1:30 P						
2) PROVIDE TECHNICAL QUESTIONS AND ANSWERS OMITTED FROM THE BREVIOUS ADDENDUM.						
3) CHANGE PARAGRAPH 1 ON PAGE 18 OF THE REQUEST FOR QUOTATION AS FOLLOWS.						
THE WEST VIRGINIA DIVISION OF NATURAL RESOURCES, HEREAFTER DIVISION, IS REQUESTING BIDS FOR THE UPGRADE AND REPLACEMENT OF KEY ENTRY LOCKS WITH ELECTRONIC CARD READING LOCKING SYSTEM AT FOUR WEST VIRGINIA STATE PARKS. ALL ITEMS ARE TO BE F.O.B. DESTINATION, DELIVER AND INSTALLATION MUST BE INCLUDED IN UNIT PRICING.						
0001	1	IS	968-42	KEY CARD LOCK SYSTEM WITH INSTALLATION		
***** THIS IS THE END OF RFQ DNR210130 *****						TOTAL: <u>\$80,408.20</u>

SEE REVERSE SIDE FOR TERMS AND CONDITIONS

SIGNATURE	TELEPHONE <b>304-252-4339</b>	DATE <b>4/21/10</b>
TITLE <b>C.O.O.</b>	FEIN <b>04-3716862</b>	ADDRESS CHANGES TO BE NOTED ABOVE

WHEN RESPONDING TO RFQ, INSERT NAME AND ADDRESS IN SPACE ABOVE LABELED 'VENDOR'



State of West Virginia  
 Department of Administration  
 Purchasing Division  
 2019 Washington Street East  
 Post Office Box 50130  
 Charleston, WV 25305-0130

**Request for  
 Quotation**

RFQ NUMBER
DNR210130

PAGE
2

ADDRESS CORRESPONDENCE TO ATTENTION OF
FRANK WHITTAKER 304-558-2316

RFQ COPY

TYPE NAME/ADDRESS HERE  
 FEIN: 04-3716862

Alpha Contracting, LLC  
 198 Prosperity Road  
 Beckley, WV 25801  
 304-252-4339

DIVISION OF NATURAL RESOURCES  
 VARIOUS LOCALES AS INDICATED  
 BY ORDER

DATE PRINTED	TERMS OF SALE	SHIP VIA	FOB	FREIGHT TERMS
03/17/2010				
BID OPENING DATE: 04/14/2010		BID OPENING TIME 01:30PM		

LINE	QUANTITY	UQP	GAT NO	ITEM NUMBER	UNIT PRICE	AMOUNT
<p>OF THE VENDOR'S COMPLIANCE WITH THE PROVISIONS OF ARTICLE 1D, CHAPTER 21 OF THE WEST VIRGINIA CODE. FAILURE TO SUBMIT THE SIGNED DRUG-FREE WORKPLACE AFFIDAVIT WITH THE BID SHALL RESULT IN DISQUALIFICATION OF SUCH BID.</p> <p>NOTICE TO PROCEED: THIS CONTRACT IS TO BE PERFORMED WITHIN 180 CALENDAR DAYS AFTER THE NOTICE TO PROCEED IS RECEIVED. UNLESS OTHERWISE SPECIFIED, THE FULLY EXECUTED PURCHASE ORDER WILL BE CONSIDERED NOTICE TO PROCEED.</p> <p>CANCELLATION: THE DIRECTOR OF PURCHASING RESERVES THE RIGHT TO CANCEL THIS CONTRACT IMMEDIATELY UPON WRITTEN NOTICE TO THE VENDOR IF THE MATERIALS OR WORKMANSHIP SUPPLIED ARE OF AN INFERIOR QUALITY OR DO NOT CONFORM WITH THE SPECIFICATIONS OF THE BID AND CONTRACT HERE IN.</p> <p>WAGE RATES: THE CONTRACTOR OR SUBCONTRACTOR SHALL PAY THE HIGHER OF THE U.S. DEPARTMENT OF LABOR MINIMUM WAGE RATES AS ESTABLISHED FOR EACH COUNTY, PURSUANT TO WEST VIRGINIA CODE 21-5A, ET, SEQ. (PREVAILING WAGE RATES APPLY TO THIS PROJECT)</p> <p>ARBITRATION: ANY REFERENCES MADE TO ARBITRATION OR INTEREST FOR PAYMENTS DUE (EXCEPT FOR ANY INTEREST REQUIRED BY STATE LAW) CONTAINED IN THIS CONTRACT OR IN ANY AMERICAN INSTITUTE OF ARCHITECTS DOCUMENTS PERTAINING TO THIS CONTRACT ARE HEREBY DELETED.</p> <p>WORKERS' COMPENSATION: VENDOR IS REQUIRED TO PROVIDE A CERTIFICATE FROM WORKERS' COMPENSATION IF SUCCESSFUL.</p> <p>ALL OF THE ITEMS CHECKED BELOW WILL BE A REQUIREMENT OF THIS CONTRACT:</p>						

SEE REVERSE SIDE FOR TERMS AND CONDITIONS

SIGNATURE	TELEPHONE	DATE
<i>[Signature]</i>	304-252-4339	4/21/10
TITLE	FEIN	ADDRESS CHANGES TO BE NOTED ABOVE
C.O.O.	04-3716862	

WHEN RESPONDING TO RFQ, INSERT NAME AND ADDRESS IN SPACE ABOVE LABELED 'VENDOR'



State of West Virginia  
 Department of Administration  
 Purchasing Division  
 2019 Washington Street East  
 Post Office Box 50130  
 Charleston, WV 25305-0130

# Request for Quotation

RFQ NUMBER  
**DNR210130**

PAGE  
**3**

ADDRESS CORRESPONDENCE TO ATTENTION OF  
**FRANK WHITTAKER**  
**304-558-2316**

PROPERTY

RFQ COPY  
 TYPE NAME/ADDRESS HERE  
 FEIN: 04-3716862

**Alpha Contracting, LLC**  
**198 Prosperity Road**  
**Beckley, WV 25801**  
**304-252-4339**

SHIP TO

**DIVISION OF NATURAL RESOURCES**  
**VARIOUS LOCALES AS INDICATED**  
**BY ORDER**

DATE PRINTED	TERMS OF SALE	SHIP VIA	F.O.B.	FREIGHT TERMS
03/17/2010				

BID OPENING DATE: **04/14/2010** BID OPENING TIME **01:30PM**

LINE	QUANTITY	UOP	CAT. NO.	ITEM NUMBER	UNIT PRICE	AMOUNT
<p>(XX) INSURANCE: SUCCESSFUL VENDOR SHALL FURNISH PROOF OF COMMERCIAL GENERAL LIABILITY INSURANCE PRIOR TO ISSUANCE OF CONTRACT. UNLESS OTHERWISE SPECIFIED IN THE BID DOCUMENTS, THE MINIMUM AMOUNT OF INSURANCE COVERAGE REQUIRED IS \$250,000.</p> <p>( ) BUILDERS RISK INSURANCE: SUCCESSFUL VENDOR SHALL FURNISH PROOF OF BUILDERS RISK - ALL RISK INSURANCE IN AN AMOUNT EQUAL TO 100% OF THE AMOUNT OF THE CONTRACT.</p> <p>(XX) BONDS: FIVE PERCENT (5%) OF THE TOTAL AMOUNT OF THE BID PAYABLE TO THE STATE OF WEST VIRGINIA, SHALL BE SUBMITTED WITH EACH BID AS A BID BOND. THE SUCCESSFUL BIDDER SHALL ALSO FURNISH A PERFORMANCE BOND AND LABOR/MATERIAL BOND FOR 100% OF THE AMOUNT OF THE CONTRACT. BONDS MAY BE PROVIDED IN THE FORM OF A CERTIFIED CHECK, IRREVOCABLE LETTER OF CREDIT, OR BOND FURNISHED BY A SOLVENT SURETY COMPANY AUTHORIZED TO DO BUSINESS IN THE STATE OF WEST VIRGINIA. A LETTER OF CREDIT SUBMITTED IN LIEU OF A BOND WILL ONLY BE ALLOWED FOR PROJECTS UNDER \$100,000. PERSONAL OR BUSINESS CHECKS ARE NOT ACCEPTABLE IN LIEU OF THE 5% BID BOND, PERFORMANCE BOND, OR LABOR AND MATERIAL BOND.</p> <p>( ) MAINTENANCE BOND: A TWO (2) YEAR MAINTENANCE BOND COVERING THE ROOFING SYSTEM WILL BE A REQUIREMENT OF THE SUCCESSFUL VENDOR.</p> <p>REV. 11/00</p> <p>EXHIBIT 7</p> <p>DOMESTIC ALUMINUM, GLASS &amp; STEEL IN PUBLIC WORKS PROJECTS</p>						

SEE REVERSE SIDE FOR TERMS AND CONDITIONS

SIGNATURE 	TELEPHONE 304-252-4339	DATE 4/21/10
TITLE C.O.O.	FEIN 04-3716862	ADDRESS CHANGES TO BE NOTED ABOVE

WHEN RESPONDING TO RFQ, INSERT NAME AND ADDRESS IN SPACE ABOVE LABELED 'VENDOR'



State of West Virginia  
 Department of Administration  
 Purchasing Division  
 2019 Washington Street East  
 Post Office Box 50130  
 Charleston, WV 25305-0130

# Request for Quotation

RFQ NUMBER  
**DNR210130**

PAGE  
**4**

ADDRESS CORRESPONDENCE TO ATTENTION OF  
**FRANK WHITTAKER**  
**304-558-2316**

VENDOR

RFQ COPY  
 TYPE NAME/ADDRESS HERE  
 FEIN: 04-3716862

Alpha Contracting, LLC  
 198 Prosperity Road  
 Beckley, WV 25801  
 304-252-4339

SHIP TO

DIVISION OF NATURAL RESOURCES  
 VARIOUS LOCALES AS INDICATED  
 BY ORDER

DATE PRINTED	TERMS OF SALE	SHIP VIA	FOB	FREIGHT TERMS
03/17/2010				

BID OPENING DATE: **04/14/2010** BID OPENING TIME **01:30PM**

LINE	QUANTITY	UOP	CAT NO	ITEM NUMBER	UNIT PRICE	AMOUNT
<p>IN ACCORDANCE WITH WEST VIRGINIA CODE 5-19-1 ET., SEQ., EVERY CONTRACT FOR CONSTRUCTION, RECONSTRUCTION, ALTERATION, REPAIR, IMPROVEMENT OR MAINTENANCE OF PUBLIC WORKS, WHERE THE COST IS MORE THAN \$50,000 AND, IN THE CASE OF STEEL ONLY, WHERE THE COST OF STEEL IS MORE THAN \$50,000 OR WHERE MORE THAN 10,000 POUNDS OF STEEL ARE REQUIRED, THE STATE WILL ACCEPT ONLY ALUMINUM GLASS, OR STEEL PRODUCTS PRODUCED IN THE UNITED STATES. IN ADDITION, ITEMS OF MACHINERY OR EQUIPMENT PURCHASED FOR USE AT THE SITE OF PUBLIC WORKS SHALL BE MADE OF DOMESTIC ALUMINUM, GLASS OR STEEL, UNLESS THE COST OF THE PRODUCT IS LESS THAN \$50,000 OR LESS THAN 10,000 POUNDS OF STEEL ARE USED IN PUBLIC WORKS PROJECTS.</p> <p>FOREIGN MADE ALUMINUM, GLASS OR STEEL PRODUCTS MAY BE ACCEPTED ONLY IF THE COST OF DOMESTIC PRODUCTS IS FOUND TO BE UNREASONABLE. SUCH COST IS UNREASONABLE IF IT IS 20% OR MORE HIGHER THAN THE BID PRICE FOR FOREIGN MADE PRODUCTS. IF THE DOMESTIC ALUMINUM, GLASS OR STEEL PRODUCTS TO BE SUPPLIED OR PRODUCED IN A "SUBSTANTIAL LABOR SURPLUS AREA", AS DEFINED BY THE UNITED STATES DEPARTMENT OF LABOR, FOREIGN PRODUCTS MAY BE SUPPLIED ONLY IF DOMESTIC PRODUCTS ARE 30% OR MORE HIGHER IN PRICE THAN THE FOREIGN MADE PRODUCTS.</p> <p>IF, PRIOR TO THE AWARD OF A CONTRACT UNDER THE ABOVE PROVISIONS, THE SPENDING OFFICER OF THE SPENDING UNIT DETERMINES THAT THERE EXISTS A BID FOR LIKE FOREIGN ALUMINUM, GLASS OR STEEL THAT IS REASONABLE AND LOWER THAN THE LOWEST BID DOMESTIC PRODUCTS, THE SPENDING OFFICE MAY REQUEST, IN WRITING, A REEVALUATION AND REDUCTION IN THE LOWEST BID FOR SUCH DOMESTIC PRODUCTS. ALL VENDORS MUST INDICATE IN THEIR BID IF THEY ARE SUPPLYING FOREIGN ALUMINUM, GLASS OR STEEL.</p> <p>REV. 3/88</p>						

SEE REVERSE SIDE FOR TERMS AND CONDITIONS

SIGNATURE <i>[Signature]</i>	TELEPHONE 304-252-4339	DATE 4/21/10
TITLE C.O.O.	FEIN 04-3716862	ADDRESS CHANGES TO BE NOTED ABOVE

WHEN RESPONDING TO RFQ, INSERT NAME AND ADDRESS IN SPACE ABOVE LABELED 'VENDOR'



State of West Virginia  
 Department of Administration  
 Purchasing Division  
 2019 Washington Street East  
 Post Office Box 50130  
 Charleston, WV 25305-0130

# Request for Quotation

RFQ NUMBER:  
**DNR210130**

PAGE:  
**5**

ADDRESS CORRESPONDENCE TO ATTENTION OF:  
**FRANK WHITTAKER  
 304-558-2316**

**RFQ COPY**  
 TYPE NAME/ADDRESS HERE  
 FEIN: 04-3716862  
 Alpha Contracting, LLC  
 198 Prosperity Road  
 Beckley, WV 25801  
 304-252-4339

**DIVISION OF NATURAL RESOURCES  
 VARIOUS LOCALES AS INDICATED  
 BY ORDER**

DATE PRINTED	TERMS OF SALE	SHIP VIA	FOB	FREIGHT TERMS		
03/17/2010						
BID OPENING DATE: 04/14/2010		BID OPENING TIME 01:30PM				
LINE	QUANTITY	UOP	CAT NO	ITEM NUMBER	UNIT PRICE	AMOUNT
<p>EXHIBIT 9</p> <p>NOTICE FOR ISSUANCE &amp; ACKNOWLEDGEMENT OF CONSTRUCTION PROJECT ADDENDA</p> <p>THE ARCHITECT/ENGINEER AND/OR AGENCY SHALL BE REQUIRED TO ABIDE BY THE FOLLOWING SCHEDULE IN ISSUING CONSTRUCTION PROJECT ADDENDA FOR STATE AGENCIES:</p> <p>(1) THE ARCHITECT/ENGINEER SHALL PREPARE THE ADDENDUM AND A LIST OF ALL PARTIES THAT HAVE PROCURED DRAWINGS AND SPECIFICATIONS FOR THE PROJECT. THE ADDENDUM AND LIST SHALL BE FORWARDED TO THE BUYER IN THE STATE PURCHASING DIVISION. THE ARCHITECT/ENGINEER SHALL ALSO SEND A COPY OF THE ADDENDUM TO THE STATE AGENCY FOR WHICH THE CONTRACT IS ISSUED.</p> <p>(2) THE BUYER SHALL SEND THE ADDENDUM TO ALL INTERESTED PARTIES AND, IF NECESSARY, EXTEND THE BID OPENING DATE. ANY ADDENDUM SHOULD BE RECEIVED BY THE BUYER WITHIN FOURTEEN (14) DAYS PRIOR TO THE BID OPENING DATE.</p> <p>(3) ALL ADDENDA SHOULD BE FORMALLY ACKNOWLEDGED BY ALL BIDDERS AND SUBMITTED TO THE STATE PURCHASING DIVISION. THE SAME RULES AND REGULATIONS THAT APPLY TO THE ORIGINAL BIDDING DOCUMENT SHALL ALSO APPLY TO AN ADDENDUM DOCUMENT. THE ONLY EXCEPTION MAY BE FOR AN ADDENDUM THAT IS ISSUED FOR THE SOLE PURPOSE OF CHANGING A BID OPENING TIME AND/OR DATE.</p> <p>REV. 11/96</p>						
SEE REVERSE SIDE FOR TERMS AND CONDITIONS						
SIGNATURE				TELEPHONE 304-252-4339	DATE 4/21/10	
TITLE C.O.O.		FEIN 04-3716862		ADDRESS CHANGES TO BE NOTED ABOVE		

WHEN RESPONDING TO RFQ, INSERT NAME AND ADDRESS IN SPACE ABOVE LABELED 'VENDOR'



State of West Virginia  
 Department of Administration  
 Purchasing Division  
 2019 Washington Street East  
 Post Office Box 50130  
 Charleston, WV 25306-0130

# Request for Quotation

RFO NUMBER  
**DNR210130**

PAGE  
**6**

ADDRESS CORRESPONDENCE TO ATTENTION OF  
**FRANK WHITTAKER**  
**304-558-2316**

VENDOR

**RFQ COPY**  
 TYPE NAME/ADDRESS HERE  
**FEIN: 04-3716862**  
**Alpha Contracting, LLC**  
**198 Prosperity Road**  
**Beckley, WV 25801**  
**304-252-4339**

SHIP TO

**DIVISION OF NATURAL RESOURCES**  
**VARIOUS LOCALES AS INDICATED**  
**BY ORDER**

DATE PRINTED	TERMS OF SALE	SHIP VIA	FOB	FREIGHT TERMS
03/17/2010				

BID OPENING DATE: **04/14/2010** BID OPENING TIME **01:30PM**

LINE	QUANTITY	UQP	CAT NO	ITEM NUMBER	UNIT PRICE	AMOUNT
<b>EXHIBIT 10</b>						
<b>ADDENDUM ACKNOWLEDGEMENT</b>						
I HEREBY ACKNOWLEDGE RECEIPT OF THE FOLLOWING CHECKED ADDENDUM(S) AND HAVE MADE THE NECESSARY REVISIONS TO MY PROPOSAL, PLANS AND/OR SPECIFICATION, ETC.						
ADDENDUM NOS.:						
NO. 1	.....		.....			
NO. 2	.....		.....			
NO. 3	.....		.....			
NO. 4	.....		.....			
NO. 5	.....		.....			
I UNDERSTAND THAT FAILURE TO CONFIRM THE RECEIPT OF THE ADDENDUM(S) MAY BE CAUSE FOR REJECTION OF THE BIDS.						
VENDOR MUST CLEARLY UNDERSTAND THAT ANY VERBAL REPRESENTATION MADE OR ASSUMED TO BE MADE DURING ANY ORAL DISCUSSION HELD BETWEEN VENDOR'S REPRESENTATIVES AND ANY STATE PERSONNEL IS NOT BINDING. ONLY THE INFORMATION ISSUED IN WRITING AND ADDED TO THE SPECIFICATIONS BY AN OFFICIAL ADDENDUM IS BINDING.						
					SIGNATURE	
					COMPANY	Alpha Contracting Inc.

SEE REVERSE SIDE FOR TERMS AND CONDITIONS

SIGNATURE	TELEPHONE <b>304-252-4339</b>	DATE <b>4/21/10</b>
TITLE <b>C.O.O.</b>	FEIN <b>04-3716862</b>	ADDRESS CHANGES TO BE NOTED ABOVE

WHEN RESPONDING TO RFQ, INSERT NAME AND ADDRESS IN SPACE ABOVE LABELED 'VENDOR'



State of West Virginia  
 Department of Administration  
 Purchasing Division  
 2019 Washington Street East  
 Post Office Box 50130  
 Charleston, WV 25305-0130

# Request for Quotation

RFQ NUMBER  
**DNR210130**

PAGE  
**7**

ADDRESS CORRESPONDENCE TO ATTENTION OF  
**FRANK WHITTAKER  
 304-558-2316**

ADDRESS

RFQ COPY  
 TYPE NAME/ADDRESS HERE  
 FEIN: 04-3716862

**Alpha Contracting, LLC  
 198 Prosperity Road  
 Beckley, WV 25801  
 304-252-4339**

ADDRESS

**DIVISION OF NATURAL RESOURCES  
 VARIOUS LOCALES AS INDICATED  
 BY ORDER**

DATE PRINTED	TERMS OF SALE	SHIP VIA	FOB	FREIGHT TERMS
03/17/2010				

BID OPENING DATE: **04/14/2010** BID OPENING TIME **01:30PM**

LINE	QUANTITY	UOP	CAT NO	ITEM NUMBER	UNIT PRICE	AMOUNT
<p>.....DATE</p> <p>REV. 11/96</p> <p><b>CONTRACTORS LICENSE</b></p> <p>WEST VIRGINIA STATE CODE 21-11-2 REQUIRES THAT ALL PERSONS DESIRING TO PERFORM CONTRACTING WORK IN THIS STATE MUST BE LICENSED. THE WEST VIRGINIA CONTRACTORS LICENSING BOARD IS EMPOWERED TO ISSUE THE CONTRACTORS LICENSE. APPLICATIONS FOR A CONTRACTORS LICENSE MAY BE MADE BY CONTACTING THE WEST VIRGINIA DIVISION OF LABOR CAPITOL COMPLEX, BUILDING 3, ROOM 319, CHARLESTON, WV 25305. TELEPHONE: (304) 558-7890.</p> <p>WEST VIRGINIA STATE CODE 21-11-11 REQUIRES ANY PROSPECTIVE BIDDER TO INCLUDE THE CONTRACTORS LICENSE NUMBER ON THEIR BID.</p> <p>BIDDER TO COMPLETE:</p> <p>CONTRACTORS NAME: ..... <i>Alpha Contracting, Inc.</i> .....</p> <p>CONTRACTORS LICENSE NO.: ..... <i>WV 033678</i> .....</p> <p>THE SUCCESSFUL BIDDER WILL BE REQUIRED TO FURNISH A COPY OF THEIR CONTRACTORS LICENSE PRIOR TO ISSUANCE OF A PURCHASE ORDER/CONTRACT</p> <p><b>APPLICABLE LAW</b></p> <p>THE WEST VIRGINIA STATE CODE, PURCHASING DIVISION RULES AND REGULATIONS, AND THE INFORMATION PROVIDED IN THE "REQUEST FOR QUOTATION" ISSUED BY THE PURCHASING DIVISION IS THE SOLE AUTHORITY GOVERNING THIS</p>						

SEE REVERSE SIDE FOR TERMS AND CONDITIONS		
SIGNATURE <i>[Signature]</i>	TELEPHONE <b>304-252-4339</b>	DATE <b>4/21/10</b>
TITLE <b>C.O.O.</b>	FEIN <b>04-3716862</b>	ADDRESS CHANGES TO BE NOTED ABOVE

WHEN RESPONDING TO RFQ, INSERT NAME AND ADDRESS IN SPACE ABOVE LABELED 'VENDOR'





State of West Virginia  
 Department of Administration  
 Purchasing Division  
 2019 Washington Street East  
 Post Office Box 50130  
 Charleston, WV 25305-0130

# Request for Quotation

RFQ NUMBER  
**DNR210130**

PAGE  
**8**

ADDRESS CORRESPONDENCE TO ATTENTION OF  
**FRANK WHITTAKER  
 304-558-2316**

PROSPERITY

RFQ COPY  
 TYPE NAME/ADDRESS HERE  
 FEIN: 04-3716862

**Alpha Contracting, LLC**  
**198 Prosperity Road**  
**Beckley, WV 25801**  
**304-252-4339**

SHIP TO

**DIVISION OF NATURAL RESOURCES  
 VARIOUS LOCALES AS INDICATED  
 BY ORDER**

DATE PRINTED	TERMS OF SALE	SHIP VIA	F.O.B.	FREIGHT TERMS
<b>03/17/2010</b>				

BID OPENING DATE: **04/14/2010** BID OPENING TIME **01:30PM**

LINE	QUANTITY	UOP	CAT NO	ITEM NUMBER	UNIT PRICE	AMOUNT
<p><b>PROCUREMENT.</b></p> <p>ANY INFORMATION PROVIDED IN SPECIFICATION MANUALS, OR ANY OTHER SOURCE, VERBAL OR WRITTEN, WHICH CONTRADICTS OR ALTERS THE INFORMATION PROVIDED FROM THE SOURCES AS DESCRIBED IN THE ABOVE PARAGRAPH IS VOID AND OF NO EFFECT.</p> <p><b>BANKRUPTCY:</b> IN THE EVENT THE VENDOR/CONTRACTOR FILES FOR BANKRUPTCY PROTECTION, THE STATE MAY DEEM THE CONTRACT NULL AND VOID, AND TERMINATE SUCH CONTRACT WITHOUT FURTHER ORDER.</p> <p>REV. 5/2009</p> <p style="text-align: center;"><b>NOTICE</b></p> <p><b>A SIGNED BID MUST BE SUBMITTED TO:</b></p> <p style="text-align: center;">DEPARTMENT OF ADMINISTRATION          PURCHASING DIVISION          BUILDING 15          2019 WASHINGTON STREET, EAST          CHARLESTON, WV 25305-0130</p> <p><b>THE BID SHOULD CONTAIN THIS INFORMATION ON THE FACE OF THE ENVELOPE OR THE BID MAY NOT BE CONSIDERED:</b></p> <p><b>SEALED BID</b></p> <p><b>BUYER:</b> 44</p> <p><b>REQ. NO.:</b> DNR210130</p>						

SEE REVERSE SIDE FOR TERMS AND CONDITIONS

SIGNATURE	TELEPHONE 304-252-4339	DATE 4/21/10
TITLE C.O.O.	FEIN 04-3716862	ADDRESS CHANGES TO BE NOTED ABOVE

WHEN RESPONDING TO RFQ, INSERT NAME AND ADDRESS IN SPACE ABOVE LABELED 'VENDOR'



State of West Virginia  
 Department of Administration  
 Purchasing Division  
 2019 Washington Street East  
 Post Office Box 50130  
 Charleston, WV 25305-0130

# Request for Quotation

RFQ NUMBER  
**DNR210130**

PAGE  
**9**

ADDRESS CORRESPONDENCE TO ATTENTION OF  
**FRANK WHITTAKER  
 304-558-2316**

VENDOR

RFQ COPY  
 TYPE NAME/ADDRESS HERE  
 FEIN: 04-3716862

**Alpha Contracting, LLC**  
**198 Prosperity Road**  
**Beckley, WV 25801**  
**304-252-4339**

SHIP TO

**DIVISION OF NATURAL RESOURCES**  
**VARIOUS LOCALES AS INDICATED**  
**BY ORDER**

DATE PRINTED	TERMS OF SALE	SHIP VIA	FOB	FREIGHT TERMS
03/17/2010				

BID OPENING DATE: **04/14/2010** BID OPENING TIME **01:30PM**

LINE	QUANTITY	UQP	CAT NO	ITEM NUMBER	UNIT PRICE	AMOUNT
<p>BID OPENING DATE: 04/14/2010</p> <p>BID OPENING TIME: 1:30 PM</p> <p>PLEASE PROVIDE A FAX NUMBER IN CASE IT IS NECESSARY TO CONTACT YOU REGARDING YOUR BID:            -----  <b>304-252-4340</b></p> <p>PLEASE PRINT OR TYPE NAME OF PERSON TO CONTACT CONCERNING THIS QUOTE:            -----  <b>Travis Hicks</b></p> <p>THE WEST VIRGINIA PURCHASING DIVISION, FOR THE AGENCY, THE WEST VIRGINIA DIVISION OF NATURAL RESOURCES, IS SOLICITING BIDS FOR KEY CARD DOOR LOCK SYSTEMS FOR FOUR WV STATE PARK LODGES, PER THE ATTACHED SPECIFICATIONS.</p> <p>ALL TECHNICAL QUESTIONS MUST BE SUBMITTED IN WRITING TO FRANK WHITTAKER IN THE PURCHASING DIVISION VIA EMAIL AT FRANK.M.WHITTAKER@WV.GOV OR VIA FAX AT 304-558-4115. DEADLINE FOR TECHNICAL QUESTIONS IS 03/29/2010 AT 3:00 PM. ALL TECHNICAL QUESTIONS WILL BE ADDRESSED BY ADDENDUM AFTER THE DEADLINE.</p> <p>EXHIBIT 5</p>						

SEE REVERSE SIDE FOR TERMS AND CONDITIONS

SIGNATURE 	TELEPHONE <b>304-252-4339</b>	DATE <b>4/21/10</b>
TITLE <b>C.O.O.</b>	FEIN <b>04-3716862</b>	ADDRESS CHANGES TO BE NOTED ABOVE

WHEN RESPONDING TO RFQ, INSERT NAME AND ADDRESS IN SPACE ABOVE LABELED 'VENDOR'



State of West Virginia  
 Department of Administration  
 Purchasing Division  
 2019 Washington Street East  
 Post Office Box 50130  
 Charleston, WV 25305-0130

# Request for Quotation

RFQ NUMBER  
**DNR210130**

PAGE  
**10**

ADDRESS CORRESPONDENCE TO ATTENTION OF  
**FRANK WHITTAKER  
 304-558-2316**

PROSPECTOR

RFQ COPY  
 TYPE NAME/ADDRESS HERE  
 FEIN: 04-3716862

Alpha Contracting, LLC  
 198 Prosperity Road  
 Beckley, WV 25801  
 304-252-4339

PROSPECTOR

DIVISION OF NATURAL RESOURCES  
 VARIOUS LOCALES AS INDICATED  
 BY ORDER

DATE PRINTED	TERMS OF SALE	SHIP VIA	FOB	FREIGHT TERMS
03/17/2010				

BID OPENING DATE: **04/14/2010** BID OPENING TIME **01:30PM**

LINE	QUANTITY	UOP	CAT NO	ITEM NUMBER	UNIT PRICE	AMOUNT
<p>WEST VIRGINIA CODE 21-1D-5 PROVIDES THAT: ANY SOLICITATION FOR A PUBLIC IMPROVEMENT CONSTRUCTION CONTRACT REQUIRES EACH VENDOR THAT SUBMITS A BID FOR THE WORK TO SUBMIT AT THE SAME TIME AN AFFIDAVIT OF COMPLIANCE WITH THE BID. THE ENCLOSED DRUG-FREE WORKPLACE AFFIDAVIT MUST BE SIGNED AND SUBMITTED WITH THE BID AS EVIDENCE OF THE VENDOR'S COMPLIANCE WITH THE PROVISIONS OF ARTICLE 1D, CHAPTER 21 OF THE WEST VIRGINIA CODE. FAILURE TO SUBMIT THE SIGNED DRUG-FREE WORKPLACE AFFIDAVIT WITH THE BID SHALL RESULT IN DISQUALIFICATION OF SUCH BID.</p> <p>NOTICE TO PROCEED: THIS CONTRACT IS TO BE PERFORMED WITHIN 180 CALENDAR DAYS AFTER THE NOTICE TO PROCEED IS RECEIVED. UNLESS OTHERWISE SPECIFIED, THE FULLY EXECUTED PURCHASE ORDER WILL BE CONSIDERED NOTICE TO PROCEED.</p> <p>CANCELLATION: THE DIRECTOR OF PURCHASING RESERVES THE RIGHT TO CANCEL THIS CONTRACT IMMEDIATELY UPON WRITTEN NOTICE TO THE VENDOR IF THE MATERIALS OR WORKMANSHIP SUPPLIED ARE OF AN INFERIOR QUALITY OR DO NOT CONFORM WITH THE SPECIFICATIONS OF THE BID AND CONTRACT HERE IN.</p> <p>WAGE RATES: THE CONTRACTOR OR SUBCONTRACTOR SHALL PAY THE HIGHER OF THE U.S. DEPARTMENT OF LABOR MINIMUM WAGE RATES AS ESTABLISHED FOR EACH COUNTY, PURSUANT TO WEST VIRGINIA CODE 21-5A, ET, SEQ. (PREVAILING WAGE RATES APPLY TO THIS PROJECT)</p> <p>ARBITRATION: ANY REFERENCES MADE TO ARBITRATION OR INTEREST FOR PAYMENTS DUE (EXCEPT FOR ANY INTEREST REQUIRED BY STATE LAW) CONTAINED IN THIS CONTRACT OR IN ANY AMERICAN INSTITUTE OF ARCHITECTS DOCUMENTS PERTAINING TO THIS CONTRACT ARE HEREBY DELETED.</p>						

SEE REVERSE SIDE FOR TERMS AND CONDITIONS

SIGNATURE 	TELEPHONE 304-252-4339	DATE 4/21/10
TITLE C.I.O.O.	FEIN 04-3716862	ADDRESS CHANGES TO BE NOTED ABOVE

WHEN RESPONDING TO RFQ, INSERT NAME AND ADDRESS IN SPACE ABOVE LABELED 'VENDOR'



State of West Virginia  
 Department of Administration  
 Purchasing Division  
 2019 Washington Street East  
 Post Office Box 50130  
 Charleston, WV 25305-0130

# Request for Quotation

RFQ NUMBER  
**DNR210130**

PAGE  
**11**

ADDRESS CORRESPONDENCE OR ATTENTION OF  
**FRANK WHITTAKER  
 304-558-2316**

A U S E C O R

**RFQ COPY**  
 TYPE NAME/ADDRESS HERE  
 FEIN: 04-3716862

**Alpha Contracting, LLC**  
 198 Prosperity Road  
 Beckley, WV 25801  
 304-252-4339

S E P T O

**DIVISION OF NATURAL RESOURCES  
 VARIOUS LOCALES AS INDICATED  
 BY ORDER**

DATE PRINTED	TERMS OF SALE	SHIP VIA	F.O.B.	FREIGHT TERMS
03/17/2010				

BID OPENING DATE: **04/14/2010** BID OPENING TIME **01:30PM**

LINE	QUANTITY	UOP	CAT NO.	ITEM NUMBER	UNIT PRICE	AMOUNT
<p><b>WORKERS' COMPENSATION: VENDOR IS REQUIRED TO PROVIDE A CERTIFICATE FROM WORKERS' COMPENSATION IF SUCCESSFUL.</b></p> <p><b>ALL OF THE ITEMS CHECKED BELOW WILL BE A REQUIREMENT OF THIS CONTRACT:</b></p> <p><b>(XX) INSURANCE: SUCCESSFUL VENDOR SHALL FURNISH PROOF OF COMMERCIAL GENERAL LIABILITY INSURANCE PRIOR TO ISSUANCE OF CONTRACT. UNLESS OTHERWISE SPECIFIED IN THE BID DOCUMENTS, THE MINIMUM AMOUNT OF INSURANCE COVERAGE REQUIRED IS \$250,000.</b></p> <p><b>( ) BUILDERS RISK INSURANCE: SUCCESSFUL VENDOR SHALL FURNISH PROOF OF BUILDERS RISK - ALL RISK INSURANCE IN AN AMOUNT EQUAL TO 100% OF THE AMOUNT OF THE CONTRACT.</b></p> <p><b>(XX) BONDS: FIVE PERCENT (5%) OF THE TOTAL AMOUNT OF THE BID PAYABLE TO THE STATE OF WEST VIRGINIA, SHALL BE SUBMITTED WITH EACH BID AS A BID BOND. THE SUCCESSFUL BIDDER SHALL ALSO FURNISH A PERFORMANCE BOND AND LABOR/MATERIAL BOND FOR 100% OF THE AMOUNT OF THE CONTRACT. BONDS MAY BE PROVIDED IN THE FORM OF A CERTIFIED CHECK, IRREVOCABLE LETTER OF CREDIT, OR BOND FURNISHED BY A SOLVENT SURETY COMPANY AUTHORIZED TO DO BUSINESS IN THE STATE OF WEST VIRGINIA. A LETTER OF CREDIT SUBMITTED IN LIEU OF A BOND WILL ONLY BE ALLOWED FOR PROJECTS UNDER \$100,000. PERSONAL OR BUSINESS CHECKS ARE NOT ACCEPTABLE IN LIEU OF THE 5% BID BOND, PERFORMANCE BOND, OR LABOR AND MATERIAL BOND.</b></p> <p><b>( ) MAINTENANCE BOND: A TWO (2) YEAR MAINTENANCE BOND COVERING THE ROOFING SYSTEM WILL BE A REQUIREMENT OF THE SUCCESSFUL VENDOR.</b></p> <p>REV. 11/00</p>						

SEE REVERSE SIDE FOR TERMS AND CONDITIONS

SIGNATURE 	TELEPHONE 304-252-4339	DATE 4/21/10
TITLE C.O.O.	FEIN 04-3716862	ADDRESS CHANGES TO BE NOTED ABOVE

WHEN RESPONDING TO RFQ, INSERT NAME AND ADDRESS IN SPACE ABOVE LABELED 'VENDOR'



State of West Virginia  
 Department of Administration  
 Purchasing Division  
 2019 Washington Street East  
 Post Office Box 50130  
 Charleston, WV 25305-0130

# Request for Quotation

RFQ NUMBER  
**DNR210130**

PAGE  
**12**

ADDRESS CORRESPONDENCE TO ATTENTION OF  
**FRANK WHITTAKER**  
**304-558-2316**

PROSPECTOR

RFQ COPY  
 TYPE NAME/ADDRESS HERE  
 FEIN: 04-3716862  
 Alpha Contracting, LLC  
 198 Prosperity Road  
 Beckley, WV 25801  
 304-252-4339

SHIP TO

DIVISION OF NATURAL RESOURCES  
 VARIOUS LOCALES AS INDICATED  
 BY ORDER

DATE PRINTED	TERMS OF SALE	SHIP VIA	FOB	FREIGHT TERMS
03/17/2010				

BID OPENING DATE: **04/14/2010** BID OPENING TIME **01:30PM**

LINE	QUANTITY	UOP	CAT NO	ITEM NUMBER	UNIT PRICE	AMOUNT
<p><b>EXHIBIT 7</b></p> <p><b>DOMESTIC ALUMINUM, GLASS &amp; STEEL IN PUBLIC WORKS PROJECTS</b></p> <p>IN ACCORDANCE WITH WEST VIRGINIA CODE 5-19-1 ET., SEQ., EVERY CONTRACT FOR CONSTRUCTION, RECONSTRUCTION, ALTERATION, REPAIR, IMPROVEMENT OR MAINTENANCE OF PUBLIC WORKS, WHERE THE COST IS MORE THAN \$50,000 AND, IN THE CASE OF STEEL ONLY, WHERE THE COST OF STEEL IS MORE THAN \$50,000 OR WHERE MORE THAN 10,000 POUNDS OF STEEL ARE REQUIRED, THE STATE WILL ACCEPT ONLY ALUMINUM GLASS, OR STEEL PRODUCTS PRODUCED IN THE UNITED STATES. IN ADDITION, ITEMS OF MACHINERY OR EQUIPMENT PURCHASED FOR USE AT THE SITE OF PUBLIC WORKS SHALL BE MADE OF DOMESTIC ALUMINUM, GLASS OR STEEL, UNLESS THE COST OF THE PRODUCT IS LESS THAN \$50,000 OR LESS THAN 10,000 POUNDS OF STEEL ARE USED IN PUBLIC WORKS PROJECTS.</p> <p>FOREIGN MADE ALUMINUM, GLASS OR STEEL PRODUCTS MAY BE ACCEPTED ONLY IF THE COST OF DOMESTIC PRODUCTS IS FOUND TO BE UNREASONABLE. SUCH COST IS UNREASONABLE IF IT IS 20% OR MORE HIGHER THAN THE BID PRICE FOR FOREIGN MADE PRODUCTS. IF THE DOMESTIC ALUMINUM, GLASS OR STEEL PRODUCTS TO BE SUPPLIED OR PRODUCED IN A "SUBSTANTIAL LABOR SURPLUS AREA", AS DEFINED BY THE UNITED STATES DEPARTMENT OF LABOR, FOREIGN PRODUCTS MAY BE SUPPLIED ONLY IF DOMESTIC PRODUCTS ARE 30% OR MORE HIGHER IN PRICE THAN THE FOREIGN MADE PRODUCTS.</p> <p>IF, PRIOR TO THE AWARD OF A CONTRACT UNDER THE ABOVE PROVISIONS, THE SPENDING OFFICER OF THE SPENDING UNIT DETERMINES THAT THERE EXISTS A BID FOR LIKE FOREIGN ALUMINUM, GLASS OR STEEL THAT IS REASONABLE AND LOWER THAN THE LOWEST BID DOMESTIC PRODUCTS, THE SPENDING</p>						

SEE REVERSE SIDE FOR TERMS AND CONDITIONS

SIGNATURE <i>[Signature]</i>	TELEPHONE 304-252-4339	DATE 4/21/10
TITLE C.O.O.	FEIN 04-3716862	ADDRESS CHANGES TO BE NOTED ABOVE

WHEN RESPONDING TO RFQ, INSERT NAME AND ADDRESS IN SPACE ABOVE LABELED 'VENDOR'



State of West Virginia  
 Department of Administration  
 Purchasing Division  
 2019 Washington Street East  
 Post Office Box 50130  
 Charleston, WV 25305-0130

# Request for Quotation

RFQ NUMBER  
**DNR210130**

PAGE  
**13**

ADDRESS CORRESPONDENCE TO ATTENTION OF  
**FRANK WHITTAKER  
 304-558-2316**

PROSPERITY

RFQ COPY  
 TYPE NAME/ADDRESS HERE  
 FEIN: 04-3716862

**Alpha Contracting, LLC  
 198 Prosperity Road  
 Beckley, WV 25801  
 304-252-4339**

SHIP TO

**DIVISION OF NATURAL RESOURCES  
 VARIOUS LOCALES AS INDICATED  
 BY ORDER**

DATE PRINTED	TERMS OF SALE	SHIP VIA	F.O.B.	FREIGHT TERMS
03/17/2010				

BID OPENING DATE: **04/14/2010** BID OPENING TIME **01:30PM**

LINE	QUANTITY	LOP	CAT. NO.	ITEM NUMBER	UNIT PRICE	AMOUNT
<p>OFFICE MAY REQUEST, IN WRITING, A REEVALUATION AND REDUCTION IN THE LOWEST BID FOR SUCH DOMESTIC PRODUCTS. ALL VENDORS MUST INDICATE IN THEIR BID IF THEY ARE SUPPLYING FOREIGN ALUMINUM, GLASS OR STEEL.</p> <p>REV. 3/88</p> <p>EXHIBIT 9</p> <p>NOTICE FOR ISSUANCE &amp; ACKNOWLEDGEMENT OF CONSTRUCTION PROJECT ADDENDA</p> <p>THE ARCHITECT/ENGINEER AND/OR AGENCY SHALL BE REQUIRED TO ABIDE BY THE FOLLOWING SCHEDULE IN ISSUING CONSTRUCTION PROJECT ADDENDA FOR STATE AGENCIES:</p> <p>(1) THE ARCHITECT/ENGINEER SHALL PREPARE THE ADDENDUM AND A LIST OF ALL PARTIES THAT HAVE PROCURED DRAWINGS AND SPECIFICATIONS FOR THE PROJECT. THE ADDENDUM AND LIST SHALL BE FORWARDED TO THE BUYER IN THE STATE PURCHASING DIVISION. THE ARCHITECT/ENGINEER SHALL ALSO SEND A COPY OF THE ADDENDUM TO THE STATE AGENCY FOR WHICH THE CONTRACT IS ISSUED.</p> <p>(2) THE BUYER SHALL SEND THE ADDENDUM TO ALL INTERESTED PARTIES AND, IF NECESSARY, EXTEND THE BID OPENING DATE. ANY ADDENDUM SHOULD BE RECEIVED BY THE BUYER WITHIN FOURTEEN (14) DAYS PRIOR TO THE BID OPENING DATE.</p> <p>(3) ALL ADDENDA SHOULD BE FORMALLY ACKNOWLEDGED BY ALL BIDDERS AND SUBMITTED TO THE STATE PURCHASING DIVISION. THE SAME RULES AND REGULATIONS THAT APPLY TO THE ORIGINAL BIDDING DOCUMENT SHALL ALSO APPLY TO AN ADDENDUM DOCUMENT. THE ONLY</p>						

SEE REVERSE SIDE FOR TERMS AND CONDITIONS

SIGNATURE	TELEPHONE <b>304-252-4339</b>	DATE <b>4/21/10</b>
TITLE <b>C.O.O.</b>	FEIN <b>04-3716862</b>	ADDRESS CHANGES TO BE NOTED ABOVE

WHEN RESPONDING TO RFQ, INSERT NAME AND ADDRESS IN SPACE ABOVE LABELED 'VENDOR'



State of West Virginia  
 Department of Administration  
 Purchasing Division  
 2019 Washington Street East  
 Post Office Box 50130  
 Charleston, WV 25305-0130

**Request for Quotation**

RFQ NUMBER  
**DNR210130**

PAGE  
**14**

ADDRESS CORRESPONDENCE TO ATTENTION OF  
**FRANK WHITTAKER  
 304-558-2316**

RFQ COPY  
 TYPE NAME/ADDRESS HERE  
 FEIN: 04-3716862  
**Alpha Contracting, LLC  
 198 Prosperity Road  
 Beckley, WV 25801  
 304-252-4339**

**DIVISION OF NATURAL RESOURCES  
 VARIOUS LOCALES AS INDICATED  
 BY ORDER**

DATE PRINTED	TERMS OF SALE	SHIP VIA	FOB	FREIGHT TERMS
03/17/2010				

BID OPENING DATE: **04/14/2010** **BID OPENING TIME 01:30PM**

LINE	QUANTITY	UOF	QAT NO.	ITEM NUMBER	UNIT PRICE	AMOUNT
<p>EXCEPTION MAY BE FOR AN ADDENDUM THAT IS ISSUED FOR THE SOLE PURPOSE OF CHANGING A BID OPENING TIME AND/OR DATE.</p> <p>REV. 11/96</p> <p>EXHIBIT 10</p> <p>ADDENDUM ACKNOWLEDGEMENT</p> <p>I HEREBY ACKNOWLEDGE RECEIPT OF THE FOLLOWING CHECKED ADDENDUM(S) AND HAVE MADE THE NECESSARY REVISIONS TO MY PROPOSAL, PLANS AND/OR SPECIFICATION, ETC.</p> <p>ADDENDUM NOS.:</p> <p>NO. 1 ..... <i>[Signature]</i></p> <p>NO. 2 ..... <i>[Signature]</i></p> <p>NO. 3 .....</p> <p>NO. 4 .....</p> <p>NO. 5 .....</p> <p>I UNDERSTAND THAT FAILURE TO CONFIRM THE RECEIPT OF THE ADDENDUM(S) MAY BE CAUSE FOR REJECTION OF THE BIDS.</p> <p>VENDOR MUST CLEARLY UNDERSTAND THAT ANY VERBAL REPRESENTATION MADE OR ASSUMED TO BE MADE DURING ANY ORAL DISCUSSION HELD BETWEEN VENDOR'S REPRESENTATIVES AND ANY STATE PERSONNEL IS NOT BINDING. ONLY THE INFORMATION ISSUED IN WRITING AND ADDED TO THE SPECIFICATIONS BY AN OFFICIAL ADDENDUM IS BINDING.</p>						

SEE REVERSE SIDE FOR TERMS AND CONDITIONS

SIGNATURE *[Signature]* TELEPHONE **304-252-4339** DATE **4/21/10**

TITLE **C.O.O.** FEIN **04-3716862** ADDRESS CHANGES TO BE NOTED ABOVE

WHEN RESPONDING TO RFQ, INSERT NAME AND ADDRESS IN SPACE ABOVE LABELED 'VENDOR'



State of West Virginia  
 Department of Administration  
 Purchasing Division  
 2019 Washington Street East  
 Post Office Box 50130  
 Charleston, WV 25305-0130

# Request for Quotation

RFQ NUMBER  
**DNR210130**

PAGE  
**15**

ADDRESS CORRESPONDENCE TO ATTENTION OF  
**FRANK WHITTAKER  
 304-558-2316**

**RFQ COPY**  
 TYPE NAME/ADDRESS HERE  
 FEIN: 04-3716862  
 Alpha Contracting, LLC  
 198 Prosperity Road  
 Beckley, WV 25801  
 304-252-4339

**SUBJECT**  
 DIVISION OF NATURAL RESOURCES  
 VARIOUS LOCALES AS INDICATED  
 BY ORDER

DATE PRINTED <b>03/17/2010</b>	TERMS OF SALE	SHIP VIA	FOB	FREIGHT TERMS
-----------------------------------	---------------	----------	-----	---------------

BID OPENING DATE: **04/14/2010** BID OPENING TIME **01:30PM**

LINE	QUANTITY	UOP	CAT NO	ITEM NUMBER	UNIT PRICE	AMOUNT
<p>..... SIGNATURE</p> <p>..... COMPANY</p> <p>..... DATE</p> <p>REV. 11/96</p> <p>CONTRACTORS LICENSE</p> <p>WEST VIRGINIA STATE CODE 21-11-2 REQUIRES THAT ALL PERSONS DESIRING TO PERFORM CONTRACTING WORK IN THIS STATE MUST BE LICENSED. THE WEST VIRGINIA CONTRACTORS LICENSING BOARD IS EMPOWERED TO ISSUE THE CONTRACTORS LICENSE. APPLICATIONS FOR A CONTRACTORS LICENSE MAY B MADE BY CONTACTING THE WEST VIRGINIA DIVISION OF LABOR CAPITOL COMPLEX, BUILDING 3, ROOM 319, CHARLESTON, WV 25305. TELEPHONE: (304) 558-7890.</p> <p>WEST VIRGINIA STATE CODE 21-11-11 REQUIRES ANY PROSPECTIVE BIDDER TO INCLUDE THE CONTRACTORS LICENSE NUMBER ON THEIR BID.</p> <p>BIDDER TO COMPLETE:</p> <p>CONTRACTORS NAME: ..... Alpha Contracting Inc. ....</p> <p>CONTRACTORS LICENSE NO.: ..... WV 033678 .....</p> <p>THE SUCCESSFUL BIDDER WILL BE REQUIRED TO FURNISH A COPY OF THEIR CONTRACTORS LICENSE PRIOR TO ISSUANCE OF A PURCHASE ORDER/CONTRACT</p>						

SEE REVERSE SIDE FOR TERMS AND CONDITIONS

SIGNATURE	TELEPHONE <b>304-252-4339</b>	DATE <b>4/21/10</b>
TITLE <b>C.O.O.</b>	FEIN <b>04-3716862</b>	ADDRESS CHANGES TO BE NOTED ABOVE

WHEN RESPONDING TO RFQ, INSERT NAME AND ADDRESS IN SPACE ABOVE LABELED 'VENDOR'





State of West Virginia  
 Department of Administration  
 Purchasing Division  
 2019 Washington Street East  
 Post Office Box 50130  
 Charleston, WV 25305-0130

**Request for  
 Quotation**

RFQ NUMBER  
**DNR210130**

PAGE  
**16**

ADDRESS CORRESPONDENCE TO ATTENTION OF  
**FRANK WHITTAKER  
 304-558-2316**

RFQ COPY

TYPE NAME / ADDRESS HERE  
 FEIN: 04-3716862  
 FEIN: 04-3716862

Alpha Contracting, LLC  
 198 Prosperity Road  
 Beckley, WV 25801  
 304-252-4339

DIVISION OF NATURAL RESOURCES  
 VARIOUS LOCALES AS INDICATED  
 BY ORDER

DATE PRINTED	TERMS OF SALE	SHIP VIA	FOB	FREIGHT TERMS
03/17/2010				

BID OPENING DATE: **04/14/2010** BID OPENING TIME **01:30PM**

LINE	QUANTITY	UOM	CAT NO	ITEM NUMBER	UNIT PRICE	AMOUNT
<p><b>APPLICABLE LAW</b></p> <p>THE WEST VIRGINIA STATE CODE, PURCHASING DIVISION RULES AND REGULATIONS, AND THE INFORMATION PROVIDED IN THE "REQUEST FOR QUOTATION" ISSUED BY THE PURCHASING DIVISION IS THE SOLE AUTHORITY GOVERNING THIS PROCUREMENT.</p> <p>ANY INFORMATION PROVIDED IN SPECIFICATION MANUALS, OR ANY OTHER SOURCE, VERBAL OR WRITTEN, WHICH CONTRADICTS OR ALTERS THE INFORMATION PROVIDED FROM THE SOURCES AS DESCRIBED IN THE ABOVE PARAGRAPH IS VOID AND OF NO EFFECT.</p> <p>BANKRUPTCY: IN THE EVENT THE VENDDR/CONTRACTOR FILES FOR BANKRUPTCY PROTECTION, THE STATE MAY DEEM THE CONTRACT NULL AND VOID, AND TERMINATE SUCH CONTRACT WITHOUT FURTHER ORDER.</p> <p>REV. 5/2009</p> <p><b>NOTICE</b></p> <p>A SIGNED BID MUST BE SUBMITTED TO:</p> <p>DEPARTMENT OF ADMINISTRATION          PURCHASING DIVISION          BUILDING 15          2019 WASHINGTON STREET, EAST          CHARLESTON, WV 25305-0130</p> <p>THE BID SHOULD CONTAIN THIS INFORMATION ON THE FACE OF THE ENVELOPE OR THE BID MAY NOT BE CONSIDERED:</p>						

SEE REVERSE SIDE FOR TERMS AND CONDITIONS

SIGNATURE  TELEPHONE **304-252-4339** DATE **4/21/10**  
 TITLE **C.O.O.** FEIN **04-3716862** ADDRESS CHANGES TO BE NOTED ABOVE

WHEN RESPONDING TO RFQ, INSERT NAME AND ADDRESS IN SPACE ABOVE LABELED 'VENDOR'



State of West Virginia  
 Department of Administration  
 Purchasing Division  
 2019 Washington Street East  
 Post Office Box 50130  
 Charleston, WV 25305-0130

# Request for Quotation

RFQ NUMBER  
**DNR210130**

PAGE  
**17**

ADDRESS CORRESPONDENCE TO ATTENTION OF  
**FRANK WHITTAKER**  
**304-558-2316**

RFQ COPY

TYPE NAME/ADDRESS HERE  
 FEIN: 04-3716862

**Alpha Contracting, LLC**  
**198 Prosperity Road**  
**Beckley, WV 25801**  
**304-252-4339**

RFQ COPY

**DIVISION OF NATURAL RESOURCES**  
**VARIOUS LOCALES AS INDICATED**  
**BY ORDER**

DATE PRINTED	TERMS OF SALE	SHIP VIA	FOB	FREIGHT TERMS
<b>03/17/2010</b>				

BID OPENING DATE: **04/14/2010** BID OPENING TIME **01:30PM**

LINE	QUANTITY	LOP	CAT NO	ITEM NUMBER	UNIT PRICE	AMOUNT
<b>SEALED BID</b>						
<b>BUYER:</b>				<b>44</b>		
<b>REQ. NO.:</b>				<b>DNR210130</b>		
<b>BID OPENING DATE:</b>				<b>04/14/2010</b>		
<b>BID OPENING TIME:</b>				<b>1:30 PM</b>		
PLEASE PROVIDE A FAX NUMBER IN CASE IT IS NECESSARY TO CONTACT YOU REGARDING YOUR BID:						
				<b>304-252-4340</b>	-----	
PLEASE PRINT OR TYPE NAME OF PERSON TO CONTACT CONCERNING THIS QUOTE:						
				<b>Travis Hicks</b>	-----	
***** THIS IS THE END OF RFQ DNR210130 ***** TOTAL:						<b>\$80,408.20</b>

SEE REVERSE SIDE FOR TERMS AND CONDITIONS

SIGNATURE	TELEPHONE <b>304-252-4339</b>	DATE <b>4/21/10</b>
TITLE <b>C.O.O.</b>	FEIN <b>04-3716862</b>	ADDRESS CHANGES TO BE NOTED ABOVE

WHEN RESPONDING TO RFQ, INSERT NAME AND ADDRESS IN SPACE ABOVE LABELED 'VENDOR'



State of West Virginia  
 Department of Administration  
 Purchasing Division  
 2019 Washington Street East  
 Post Office Box 50130  
 Charleston, WV 25305-0130

# Request for Quotation

RFQ NUMBER  
**DNR210130**

PAGE  
**1**

ADDRESS CORRESPONDENCE TO ATTENTION OF  
**FRANK WHITTAKER  
 304-558-2316**

PROPERTY

RFQ COPY  
 TYPE NAME/ADDRESS HERE  
**FEIN: 04-3716862**  
**Alpha Contracting, LLC**  
**198 Prosperity Road**  
**Beckley, WV 25801**  
**304-252-4339**

SHIP TO

**DIVISION OF NATURAL RESOURCES  
 VARIOUS LOCALES AS INDICATED  
 BY ORDER**

DATE PRINTED	TERMS OF SALE	SHIP VIA	FOB	FREIGHT TERMS
04/06/2010				

BID OPENING DATE: **04/14/2010** BID OPENING TIME: **01:30PM**

LINE	QUANTITY	UOP	CAT NO	ITEM NUMBER	UNIT PRICE	AMOUNT
***** ADDENDUM NO. 1 *****						
THIS ADDENDUM IS ISSUED TO:						
1) PROVIDE THE ATTACHED TECHNICAL QUESTIONS AND ANSWER						
2) ADD ADDITIVE ALTERNATE NUMBER ONE.						
3) PROVIDE REVISED PRICING PAGE TO REFLECT ADDITIVE ALTERNATE NUMBER ONE.						
4) PROVIDE BID BOND APPLICATION AND PREPARATION INSTRUCTIONS.						
5) PROVIDE THE DRUG FREE WORKPLACE CONFORMANCE AFFIDAVIT.						
***** END ADDENDUM NO. 1 *****						
0001	1	LS		968-42		
KEY CARD LOCK SYSTEM WITH INSTALLATION						

SEE REVERSE SIDE FOR TERMS AND CONDITIONS

SIGNATURE 	TELEPHONE <b>304-252-4339</b>	DATE <b>4/21/10</b>
TITLE <b>C.O.O.</b>	FEIN <b>04-3716862</b>	ADDRESS CHANGES TO BE NOTED ABOVE

WHEN RESPONDING TO RFQ, INSERT NAME AND ADDRESS IN SPACE ABOVE LABELED 'VENDOR'



Blackwater Falls State Park, Davis WV (color satin brass)

Item	Description	Quantity	Unit Price	Extended
1	Locks for Lodge Room Doors - Inside Entrance / Standard wood door	54	\$ 374.80	\$20239.20
2	Locks For Storage and Housekeeping Doors - Inside Entrance	4	\$ 374.80	\$ 1499.20
3	Locks for Pool and Fitness Access Doors. Metal/Glass interior door. Locks shall be rated for pool and spa environment.	3	\$ 374.80	\$ 1124.40
4	Spare guest room lockset - interior Entrance	2	\$ 374.80	\$ 749.60
5	Front Desk Encoder System	1	\$ -	\$ -
6	Portable Programmer	1	\$ 2824.00	\$ 2824.00
7	New Key Cards for Guest and Master Card Use	1000	\$ 1.52	\$ 1520.00
8	New Key Cards for Emergency Card Use	100	\$ 1.52	\$ 152.00

Included

SUBTOTAL \$4326.24 \$ 28,108.20

Hawks Nest State Park, Ansted WV (color satin chrome)

Item	Description	Quantity	Unit Price	Extended
9	Locks for Lodge Room Doors - Inside Entrance / Standard wood door	23	\$ 374.80	\$ 8620.40
10	Locks for Lodge Rooms - Exterior Lockset (All Weather)	8	\$ 374.80	\$ 2998.40
11	Locks for Storage and Housekeeping Doors - Inside Entrance	5	\$ 374.80	\$ 1874.00
12	Lock for Pool Access Door. This door is an outside entrance and shall require an all weather lockset.	1	\$ 374.80	\$ 374.80
13	Locks for Lobby Doors. Metal/Glass exterior doors (All Weather)	2	\$ 374.80	\$ 749.60
14	Lock for Maintenance Office. Exterior Entrance - shall require an all weather lockset	1	\$ 374.80	\$ 374.80
15	Spare guest room lockset - interior Entrance	2	\$ 374.80	\$ 749.60
16	Front Desk Encoder System	1	\$ -	\$ -
17	Portable Programmer	1	\$ 2824.00	\$ 2824.00
18	New Key Cards for Guest and Master Card Use	1000	\$ 1.52	\$ 1520.00
19	New Key Cards for Emergency Card Use	50	\$ 1.52	\$ 760.00

Included

SUBTOTAL \$5450.64 \$ 20161.60

North Bend State Park, Cairo WV (color satin brass)

Item	Description	Quantity	Unit Price	Extended
20	Locks for Lodge Room Doors - Inside Entrance / Standard wood door	29	\$ 374.80	\$ 10869.20
21	Lock for Kitchen Access Door - Inside Entrance	1	\$ 374.80	\$ 374.80
22	Locks For Storage and Housekeeping Doors - Inside Entrance	1	\$ 374.80	\$ 374.80
23	Spare guest room lockset - Inside Entrance	2	\$ 374.80	\$ 749.60
24	Front Desk Encoder System	1	\$ -	\$ -
25	Portable Programmer	1	\$ 2824.00	\$ 2824.00
26	New Key Cards for Guest and Master Card Use	1000	\$ 1.52	\$ 1520.00
27	New Key Cards for Emergency Card Use	50	\$ 1.52	\$ 760.00

Included

SUBTOTAL \$4326.24 \$ 16782.40

Tygart Lake State Park, Grafton WV (color satin chrome)

Item	Description	Quantity	Unit Price	Extended
28	Locks for Lodge Room Doors - Inside Entrance / Standard wood door	7	\$ 374.80	\$ 2623.60
29	Locks for Lodge Rooms - Exterior Lockset (All Weather)	13	\$ 374.80	\$ 4872.40
30	Locks For Storage and Housekeeping Doors - Interior Entrance	3	\$ 374.80	\$ 1124.40
31	Spare guest room lockset	2	\$ 374.80	\$ 749.60
32	Front Desk Encoder System	1	\$ -	\$ -
33	Portable Programmer	1	\$ 2824.00	\$ 2824.00
34	New Key Cards for Guest and Master Card Use	1000	\$ 1.52	\$ 1520.00
35	New Key Cards for Emergency Card Use	50	\$ 1.52	\$ 760.00

Included

SUBTOTAL \$4326.24 \$ 13790

GRAND TOTAL ALL PARKS \$ 78848.20

AA1 Add Alternate To Provide Staff Training At One Location \$ 1560.00

GRAND TOTAL ALL PARKS WITH ADD ALTERNATE \$ 80408.20

# InnLock 800 Series

Electronic Door Lock Systems  
Hotels/Dorms/Office Buildings  
& Timeshares

807-BN: Smart Card  
817-BN: Mag Stripe  
BN-Brushed Nickel

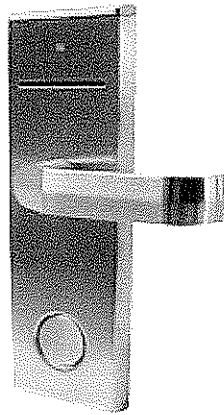

807-SB: Smart Card  
817-SB: Mag Stripe  
SB-Satin Brass

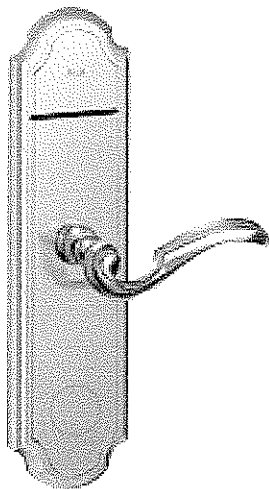
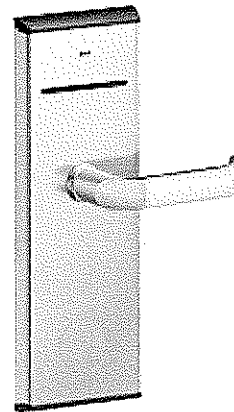

809-SC: Smart Card  
819-SC: Mag Stripe  
SC-Satin Chrome

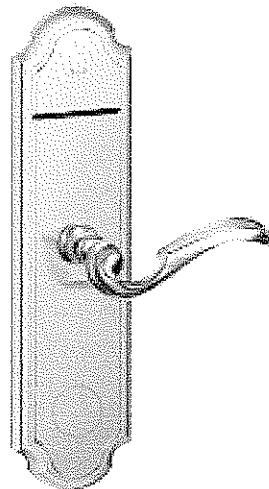

809-G: Smart Card  
819-G: Mag Stripe  
G-Gold

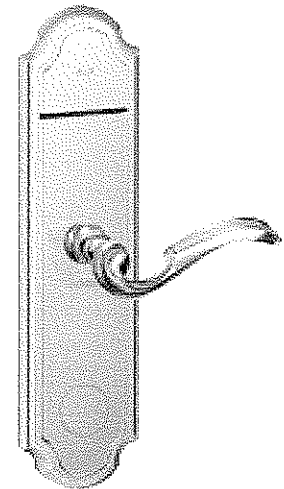

809-GBN: Smart Card  
819-GBN: Mag Stripe  
GBN-Brushed Nickel  
& Gold



Rev1.0

# InnLock 1000 Series

Radio Frequency (RF) Technology

Electronic Door Lock Systems

Hotels/Dorms/Office Buildings/Timeshares

BIO-1000  
Satin Chrome

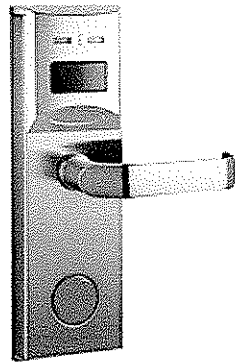

BIO-1100  
Satin Brass

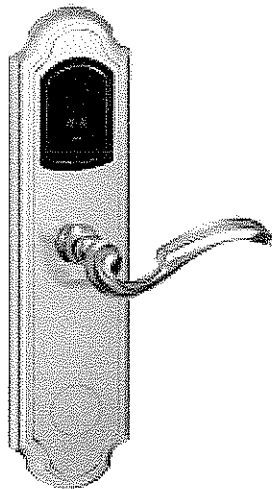
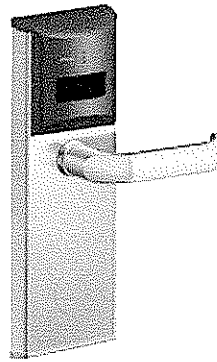

BIO-1200  
Satin Chrome

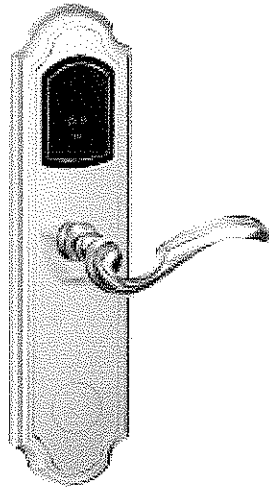

BIO-1300  
Gold

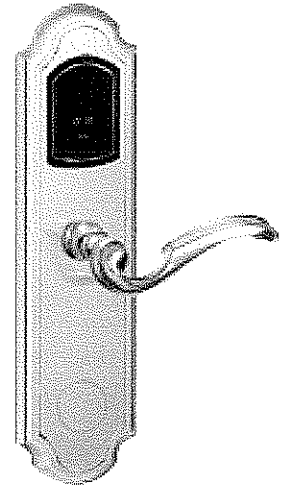

BIO-1400  
Brushed Nickel  
& Gold



Rev1.0

www.akcessbiometrics.com

## Electronic Door Lock Systems Hotels/Dorms/Office Buildings & Timeshares

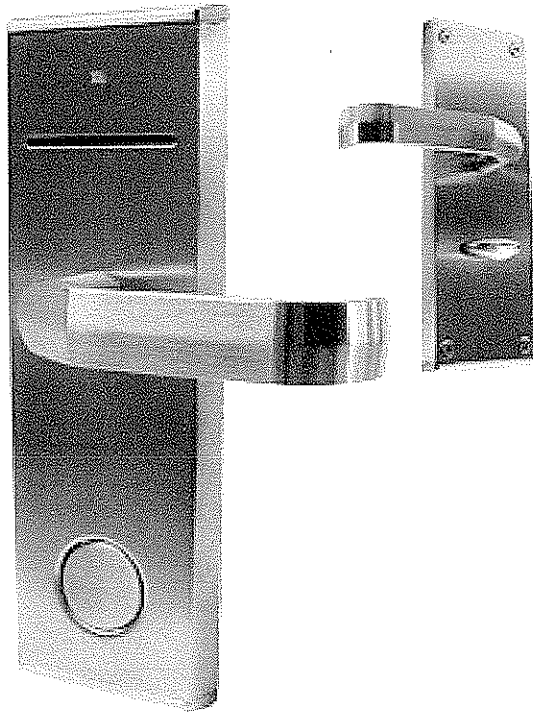

### InnLock 800

Akcess BioMetrics' InnLock 800 is an advanced door lock system for hotels, school dorms or office buildings. The InnLock System allows any front desk or security center to quickly and easily issue cards for access to rooms, gyms, pools and other types of limited access areas. The InnLock System uses a Front Desk Control System software that runs on most Windows Operating Systems. The Innlock 800 is mechanically sound and solid by design to guarantee the reliability that all institutions require. The InnLock 800 also integrates an industry standard size mortise deadbolt cylinder. The InnLock 800's body is designed with a sleek stainless steel brushed nickel color finish that is attractive on all door finishes. For a reliable door lock system inquire today!

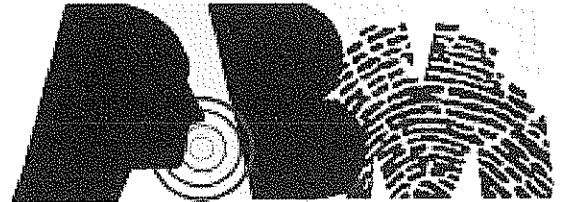

**Akcess BioMetrics Corporation**

21 Wilbraham Street  
Palmer, MA 01069  
Main 413.289.0104  
Fax 413.228.0094  
info@akcessbiometrics.com

Designed For Reliability

# InnLock 800

Electronic Door Lock Systems  
Hotels/Dorms/Office Buildings  
& Timeshares

---

## InnLock 800 Features

---

Attractive Stainless Steel Body  
High Quality Bonding Agents and Paint  
Error Free Smart Card Type Cardkey  
Storage of Name on Smart Card  
Optional Magnetic Stripe Type Cardkey  
Unlimited Cardkey Generation  
Public Door or Group Programmable  
Audit Trail Includes Date, Time & Type of Card  
Hierarchical Management Cards for Leveled Access  
Emergency Cardkeys to Open All Doors and Free Deadbolts  
Long Lasting Battery Operation  
Weatherproof for Outdoor Use  
Password Protected Software  
Hidden Mechanical Key Override  
Industry Standard Size Mortise Cylinder for Deadbolt

---

## InnLock 800 Programmer

---

- Secure administration with password
  - Flexible hotel layout for multiple buildings
  - Card issue cross check
  - Database backup and restore
  - Retrieval of transaction log records
  - Unlimited foreman and guest cardkey generation
  - Terminate Cardkey to stop door access
  - Individual cardkey expiration
  - DB9 serial port card programmer interface
  - Extended stay cardkey reprogramming
  - Intuitive user menus
  - Multiple level access by group programming
  - Extended stay cardkey reprogramming
  - Intuitive user menus
- 

## Technical Specifications

---

•Supply Voltage	4 AA Batteries	•Dimension	77 x 17 x 240 [mm]
•Amperage	18 mA	•Weight	~5 LBS
•Relative Humidity	20% - 98%	•LED	Single Multicolor
•Operating Temperature	0C - 70C	•Low Battery Indicator	by LED
•Storage Temperature	0C - 85C	•Access/Denial Indicator	by LED



www.akcessbiometrics.com

## Electronic Door Lock Systems Hotels/Dorms/Office Buildings & Timeshares



### InnLock 1000

Access BioMetrics' InnLock 1000 is an advanced door lock system for hotels, school dorms or office buildings. The 1000 series is designed using Radio Frequency (RF) Technology. All cards are read by the contactless RF reader and open space is eliminated to allow the door lock to operate in a clean and dry space. The InnLock System uses a Front Desk Control System software that runs on most Windows Operating Systems. The Innlock 1000 is mechanically sound and solid by design to guarantee the reliability that all institutions require. The InnLock 1000 also integrates an industry standard size mortise deadbolt cylinder. The InnLock 1000's body is designed with a sleek stainless steel brushed nickel color finish that is attractive on all door finishes. For a reliable door lock system inquire today!

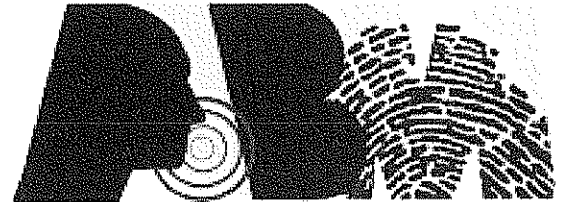

**Access BioMetrics Corporation**

21 Wilbraham Street

Palmer, MA 01069

Main 413.289.0104

Fax 413.228.0094

info@akcessbiometrics.com

**Designed For Reliability**

# InnLock 1000 Series

Radio Frequency (RF) Technology

Electronic Door Lock Systems

Hotels/Dorms/Office Buildings/Timeshares

BIO-1000  
Satin Chrome

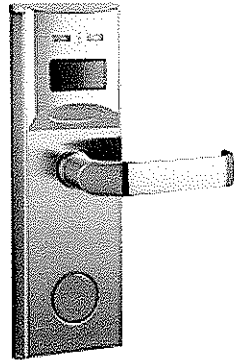

BIO-1100  
Satin Brass

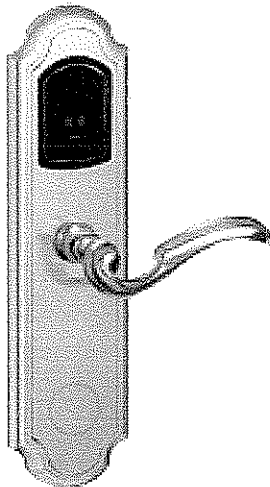
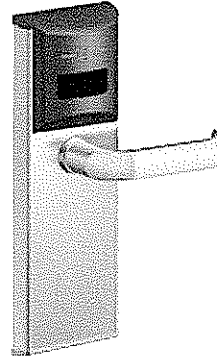

BIO-1200  
Satin Chrome

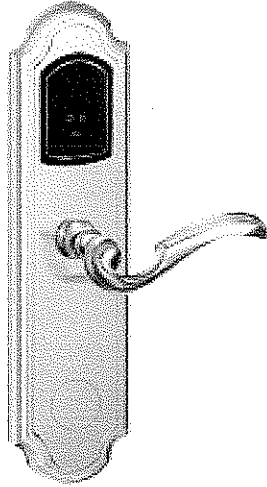

BIO-1300  
Gold

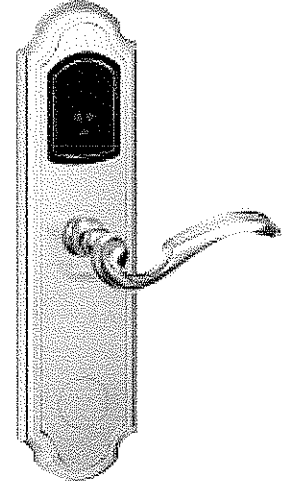

BIO-1400  
Brushed Nickel  
& Gold



Rev1.0

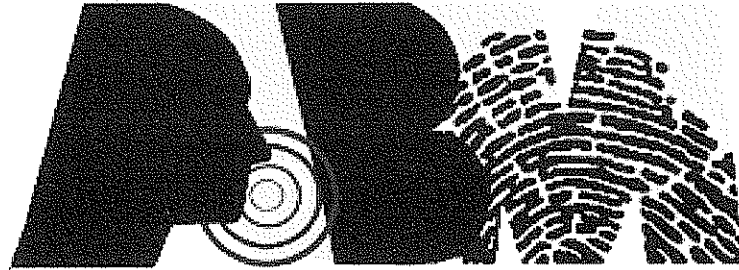

**Akcess Biometrics Corporation**  
**800 Series**  
**InnLock Installation Guide**

**Akcess Biometrics Corporation**

21 Wilbraham Street

Palmer, MA 01069

Main (413)289-0104

Fax (413)228-0094

[www.akcessbiometrics.com](http://www.akcessbiometrics.com)

[info@akcessbiometrics.com](mailto:info@akcessbiometrics.com)

## Unpacking the 800 series InnLock

The 800 series InnLock is packed with the following items:

EXTERIOR LOCK BODY (QUANTITY =1)

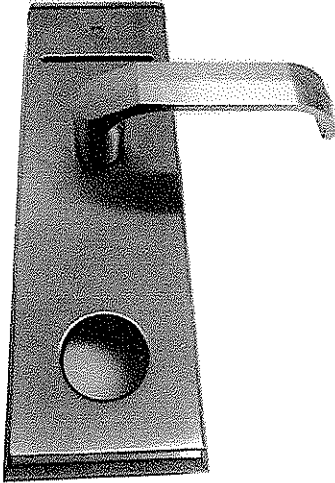

INTERIOR LOCK BODY (QUANTITY =1)



LOCK BODY SCREWS (QUANTITY =4)

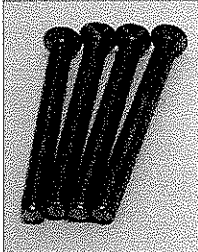

MORTISE (QUANTITY =1)

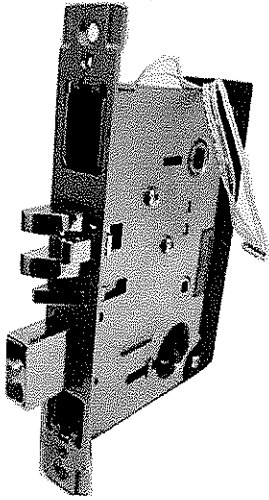

SQUARE MORTISE DRIVE (QUANTITY =2)

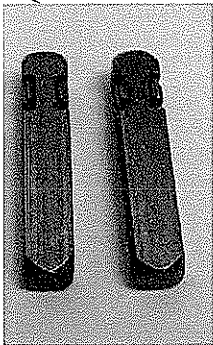

SQUARE THUMBTURN DRIVE (QUANTITY =1)

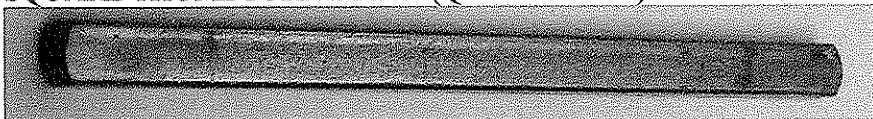

CYLINDER CAP AND KEY SET (QUANTITY =1)

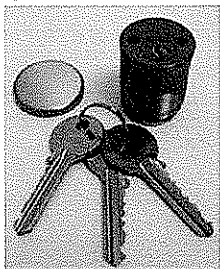

*CYLINDER, KEYS AND CYLINDER CAP*

BATTERY TRAY (QUANTITY =1)



*BATTERIES NOT INCLUDED*

STRIKE SET

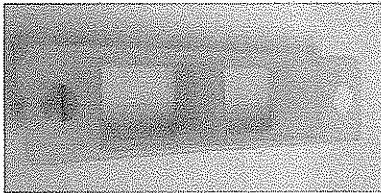

*STRIKE CUP (QUANTITY =1)*

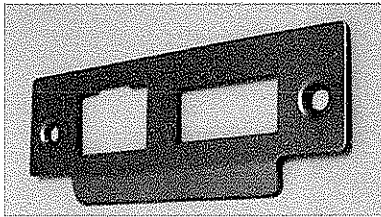

*STRIKE PLATE (QUANTITY =1)*

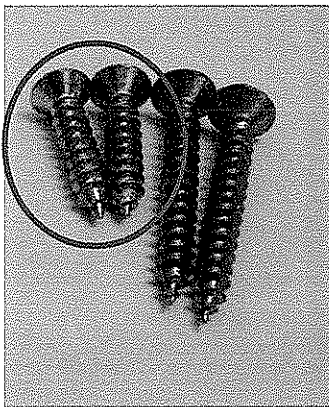

*STRIKE WOOD SCREWS (QUANTITY =2)*

MORTISE FACE PLATE (QUANTITY =1)

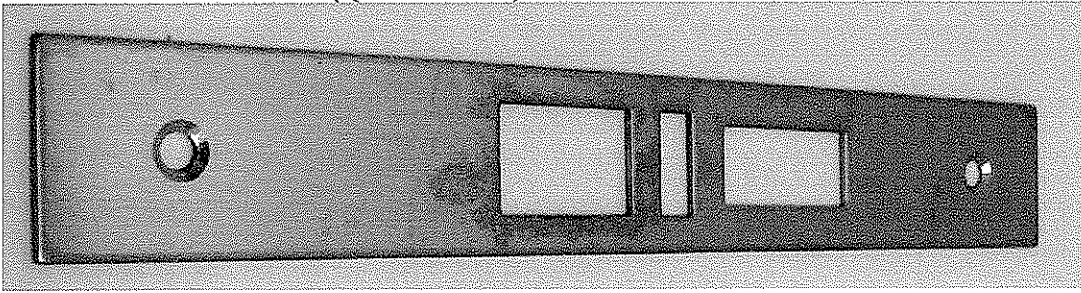

MORTISE FACE PLATE SCREWS (QUANTITY =2)

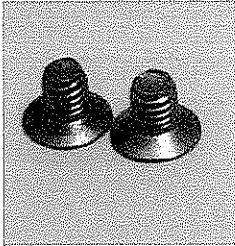

CARD READER (QUANTITY =1)

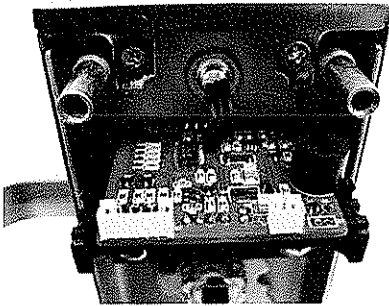

*ATTACHED TO INTERIOR LOCK BODY*

### Template for Routing a Door

*Akcess BioMetrics strongly suggests that the installer purchase a metal template guide from Akcess BioMetrics for the door cutout process. The drawings listed below are for dimensional footprint purposes only.*

800 Series Dimensional Layout for Cutout

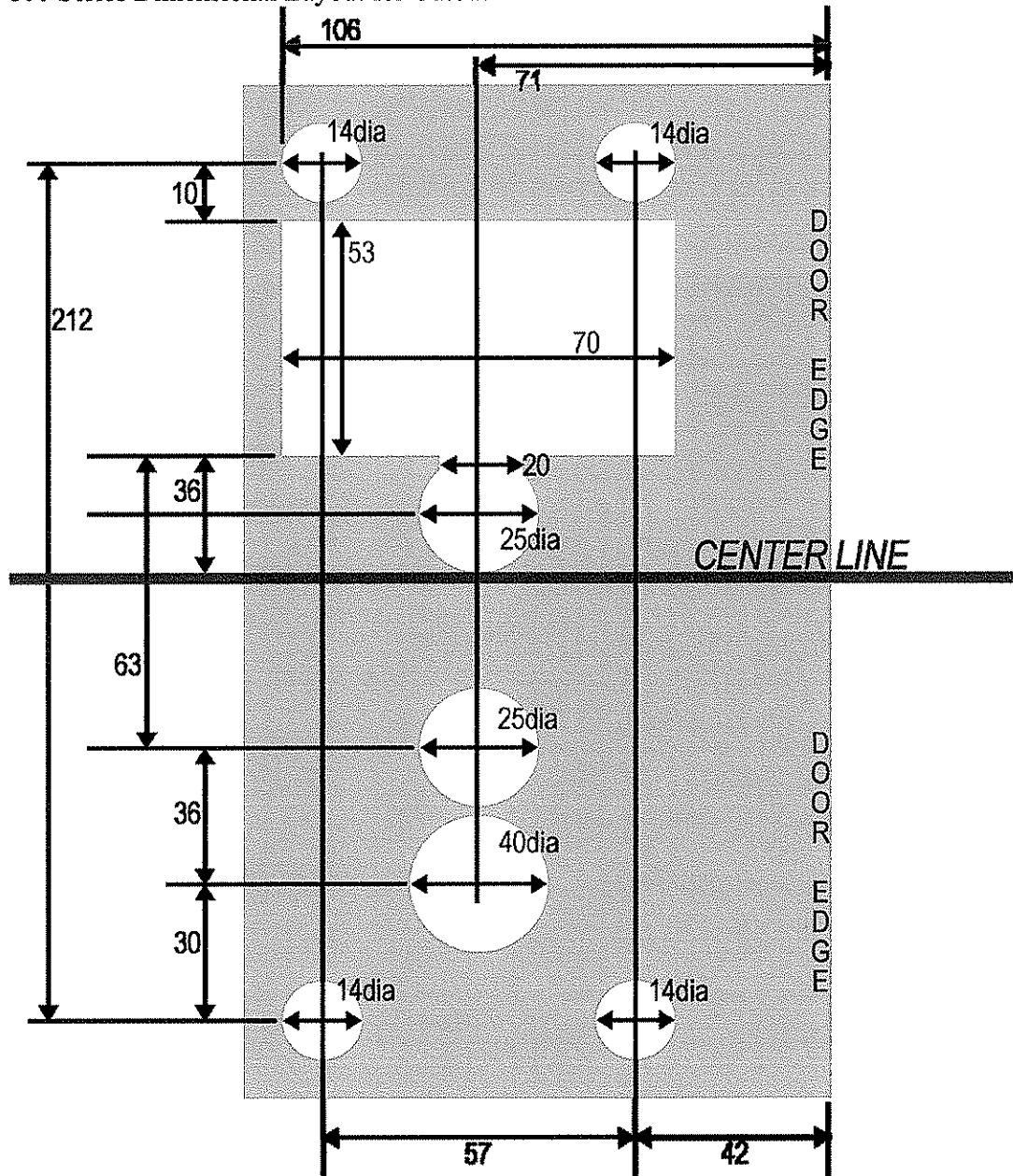

**INNLOCK 800 SERIES CUTOUT  
ALL DIMENSIONS ARE IN MILLIMETERS  
THIS DRAWING IS NOT TO SCALE**



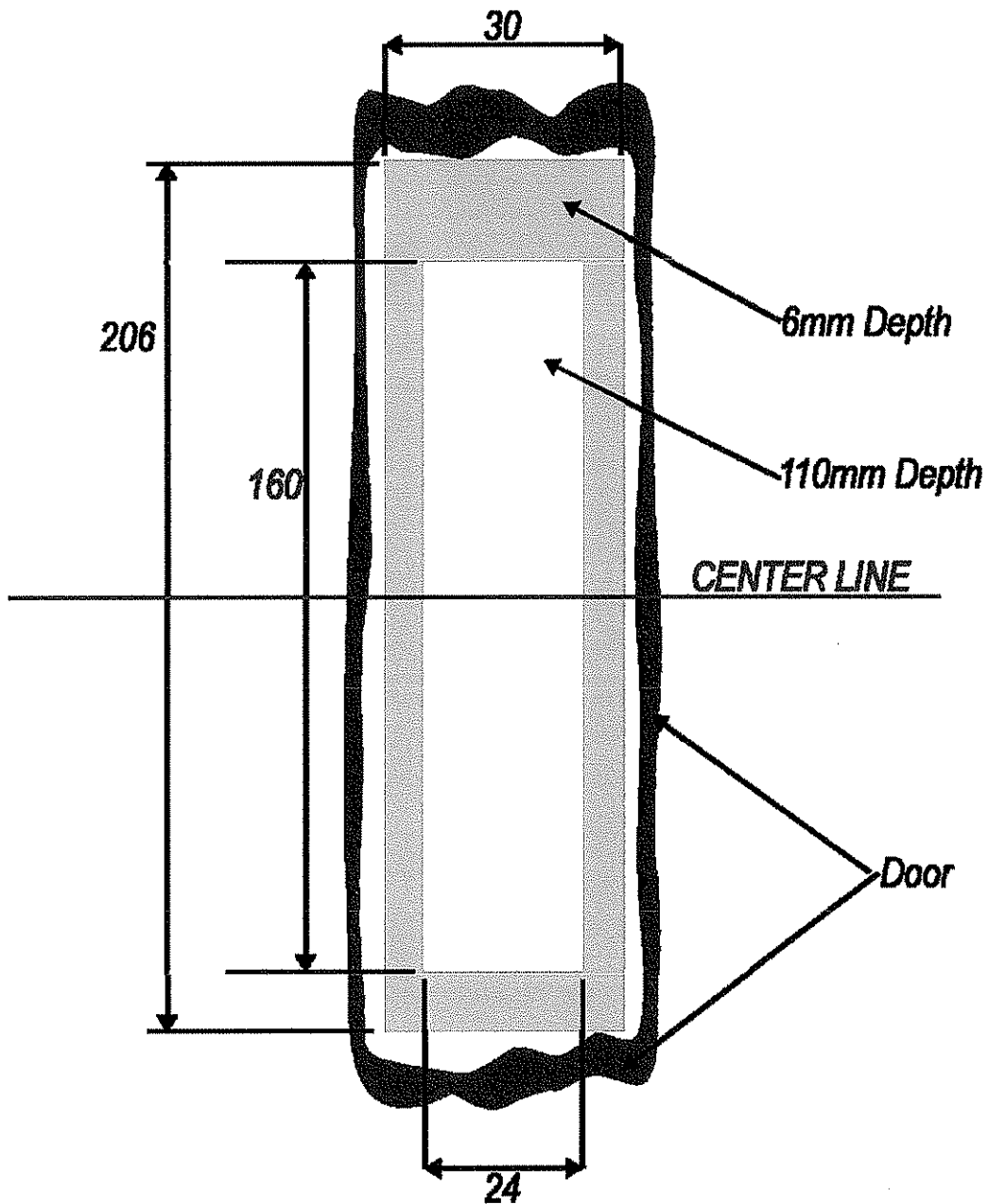

**ALL DIMENSIONS ARE IN MILLIMETERS  
THIS DRAWING IS NOT TO SCALE**

A Recommended Tool for Carpenters:

- Mortise Jig

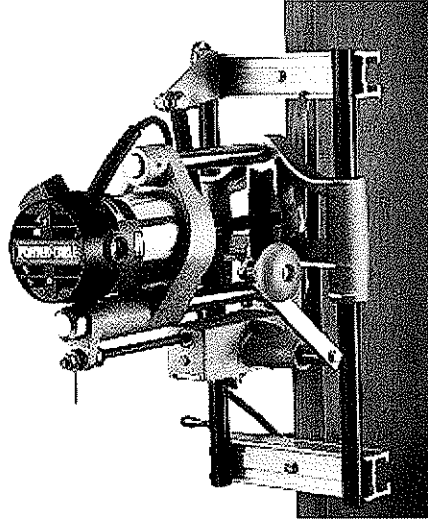

**Step 1. Insert the Mortise and drive in wood screws**

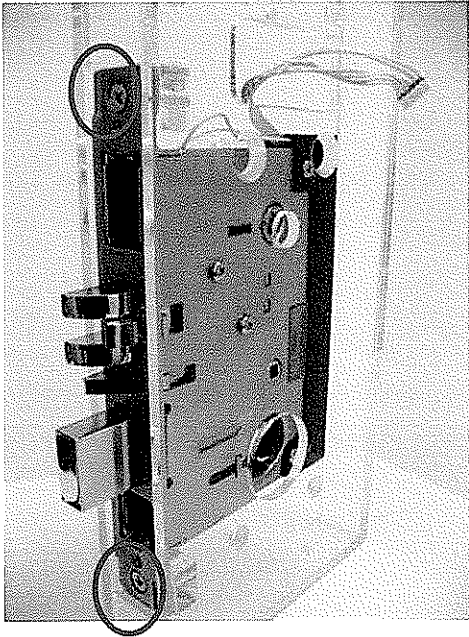

**Step 2. Hand screw the Cylinder into the Mortise**

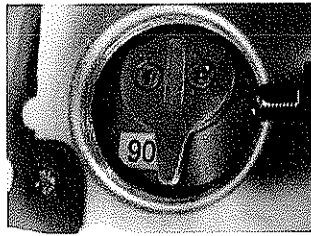
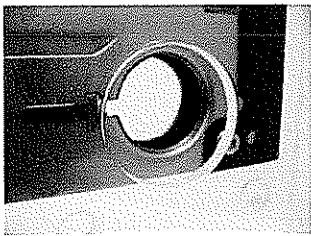

When then key is inserted into the Cylinder and turned to unlock, the arm of the Cylinder needs enough room to rotate.

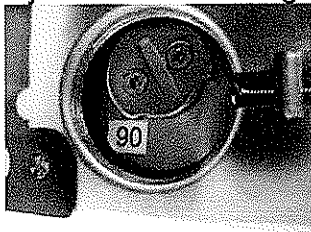

A tight fit will result in a Cylinder over screwed into the Mortise.

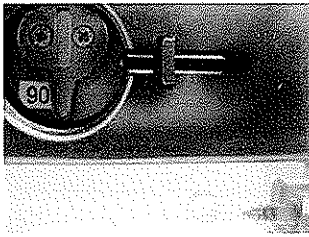

Note: The Cylinder must be in the orientation shown above to allow the locking screw to secure the Cylinder (shown in Step 3.).

### Step 3. Securing the Cylinder

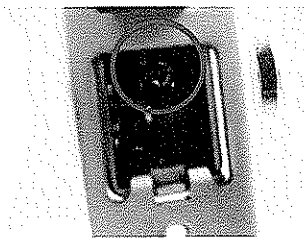

Use a philips screwdriver to turn this screw.

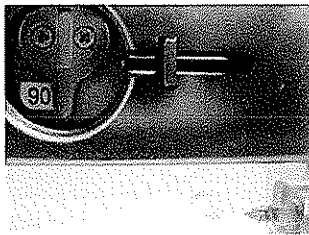

Turning the screw will extend it into the outer edge of the cylinder.

### Step 4. Insert the Square Mortise Drive into the exterior side of the Mortise

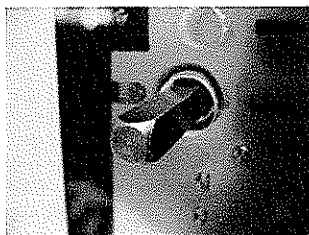

**Step 5. Position Exterior Lock Body on Door**

Note: For easy slip on of the Exterior Lock Body the square shaft that was previously inserted into the Mortise must be aligned with the lever.

**Step 6. Route and connect the mortise cable to the Card Reader**

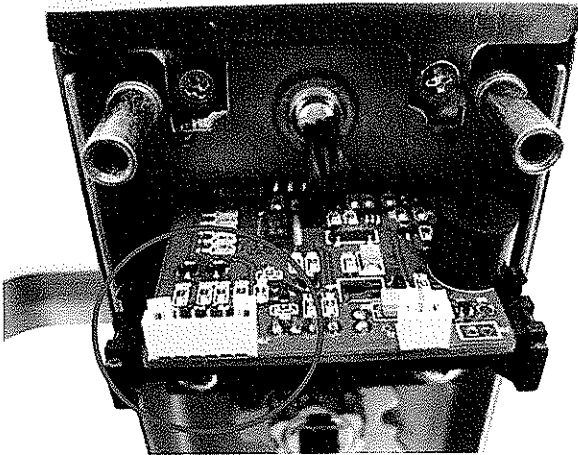

**Step 7. Mount the Battery Tray**

The battery tray will slide into the door lock through the bottom

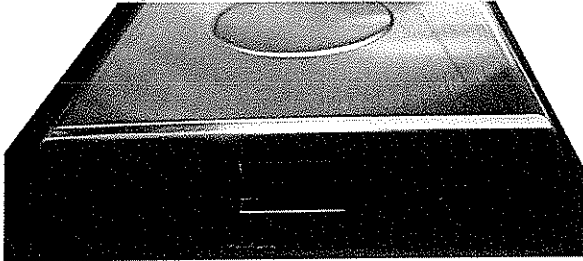

**Step 8. Route and connect the Battery Tray cable into the Card Reader**

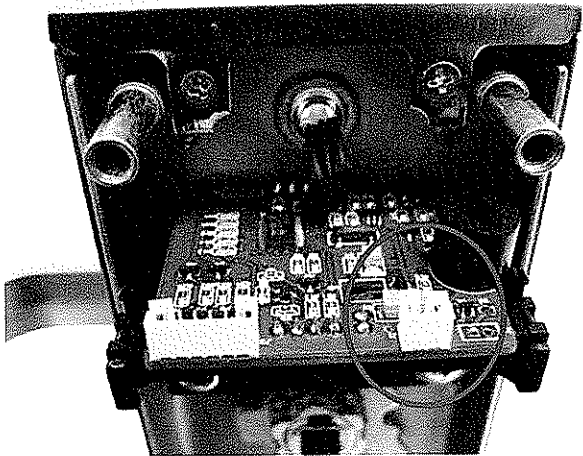

**Step 9. Insert the Square Thumbturn Drive into the Mortise**

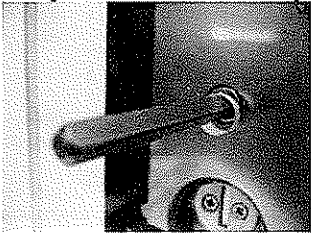

**Step 10. Mount Interior Door Lock Body and lightly screw in Lock Body Screws**



**Step 11. Attach Mortise Edge Faceplate**



### **Step 12. Check for smooth rotation from both handles**

### **Step 13. Check for smooth non binding movement of the latch and deadbolt when the key is turned**

### **Step 14. Tighten screws and test lock action again**

- Check that the door closes properly and the Mortise latch and deadbolt can be fully extended into the strike plate
- Check the lock and door frame alignment
- Inspect for any mechanical binding from over tightened screws

### FAQs

1. Why does the key turn but not unlatch the deadbolt?

Check to see that the cylinder is not inverted. When looking at the back of the cylinder and then key is rotated the arm behind the cylinder should extend high enough to touch the latching system.

2. How can I invert the cylinder if i've already secured it to the mortise?

Loosen the securing screw. Insert the key and turn. When finalizing the position of the cylinder the key hole should always be in a vertical position.

3. Everything is lined up but the action from the mortise is a little rough. How can I make it smoother?

Loosen the door lock body screws and test the action. If the action is smoother then realign the lock body and then retighten the body screws.

4. What do I do if the handle does not seem to be engaging with the mortise?

The length of the square drive shaft may be too short for the width of the door or the door lock body is not seated flat on the door.

5. Which side of the mortise is for the exterior side?

The exterior side of the mortise is the freely turning side. You can test this by inserting a screwdriver inside each side of the mortise to see which side turns freely. The freely turning side eventually engages when a valid card is read and the system activates a solenoid.

6. What happens if the freely turning side is on the wrong side for the orientation of my door.

Unfortunately you have the wrong part. The mortises are shipped preconfigured for Left Handed Outside swing (LO), Left Handed Inside swing (LI), Right Handed Outside swing (RO) or Right Handed Inside swing (RI). Consult with Akcess BioMetrics support before attempting to open and reconfigure the mortise. Opening the mortise will void the warranty on your lock.

7. What kind of lubrication can I use on the InnLock 800 series?

Silicon spray for mechanical parts is preferred.

8. How long will the batteries last?

The batteries will last approximately 18 months with average traffic.

9. When will I know it's time to change the batteries?  
A low battery indicator will appear by a blinking red light.

### **Programming the InnLock 800 Series**

**BEFORE ISSUING ANY CARDS THE REVOKE [F5] FUNCTION MUST BE USED TO CLEAR ANY CONTENTS FROM THE CARD FIRST. IF THE CARD IS NEW AND HAS NEVER BEEN PROGRAMMED THEN THE REVOKE [F5] FUNCTION DOES NOT NEED TO BE PERFORMED. IF INFORMATION EXISTS ON THE CARD AND THE REVOKE [F5] FUNCTION IS NOT PERFORMED THEN THE CARD WILL BE TERMINATED AFTER 3 PROGRAMMING ATTEMPTS. UPON TERMINATION THE CARD WILL NO LONGER BE AVAILABLE TO USE. THIS IS A SAFETY FEATURE. THIS APPLIES TO INNLOCK 807 SERIES ONLY.**

- 1) Assure batteries are installed and the Battery Tray is connected.
- 2) Insert a **TIME CARD**.
- 3) Insert a Room Card with the room number of your choice.

The InnLock 800 series will have saved the room number and time. The battery must be connected from this point on to maintain an accurate time.

#### ***RESETTING TIME***

Insert a **TIME CARD**

#### ***CHANGING THE ROOM NUMBER***

Insert a **DATA CLEAR CARD**. The **DATA CLEAR CARD** is used to clear all the data stored in a lock. This card will reset the lock to factory settings.

To clear the data from the lock:

1. Insert the override metal key into the lock. Do not turn it yet.
2. Insert the **DATA CLEAR CARD** into the lock (keep the card inside the lock) and wait for a green light.
3. Turn the override key to unlatch it and pull the dead bolt inside the mortise. Hold the key in that position for 10 seconds. **TIP: Instead of holding the key in the turned position you can also place your hand over the mortise latch to keep it from popping out. When the mortise latch is inside a switch is set. Keeping the mortise latch inside will keep this small switch pressed down. The switch needs to be pressed down for 10 seconds while the card is inside the lock.**

#### ***OTHER FUNCTIONS***

Other functions are described in the document, *Card Types and Usage*.



# CONTRACTOR LICENSE

Authorized by the

West Virginia Contractor Licensing Board

Number: WV033678

Classification:

ELECTRICAL  
EXCAVATION

ALPHA CONTRACTING INC  
DBA ALPHA CONTRACTING INC  
198 PROSPERITY ROAD  
BECKLEY, WV 25801

Date Issued

MARCH 10, 2010

Expiration Date

MARCH 10, 2011

  
Authorized Company Signature

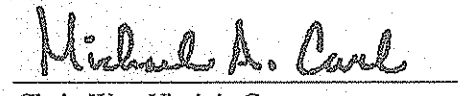
  
Chair, West Virginia Contractor  
Licensing Board

WEST VIRGINIA  
CONTRACTOR  
LICENSING  
BOARD

This license, or a copy thereof, must be posted in a conspicuous place at every construction site where work is being performed. This license number must appear in all advertisements, on all bid submissions and on all fully executed and binding contracts. This license cannot be assigned or transferred by licensee. Issued under provisions of West Virginia Code, Chapter 21, Article 11.



# CERTIFICATE OF INSURANCE

— THIS CERTIFICATE IS ISSUED AS A MATTER OF INFORMATION ONLY —

DATE (MM/DD/YY) 4/22/10
----------------------------

NAME AND ADDRESS OF AGENCY <b>MOUNTAINEER INS ASSOC., INC.</b> 583 CANTERBURY DRIVE BECKLEY, WV 25801-9453  (304)255-6163	AGENT'S NO. EE1168	<b>COMPANY(IES) AFFORDING COVERAGE</b> Co.: C ERIE INSURANCE COMPANY Co.: D ERIE INSURANCE PROPERTY & CASUALTY COMPANY Co.: E ERIE INSURANCE EXCHANGE Erie Indemnity Co., Attorney-in-Fact Co.: F ERIE INSURANCE COMPANY OF NEW YORK Co.: G FLAGSHIP CITY INSURANCE COMPANY
--	-----------------------	---

NAME AND MAILING ADDRESS OF INSURED Doug Hicks Electric Co Inc Alpha Contracting Inc ATIMA 198 Prosperity Rd Beckley, WV 25801	This Certificate is issued for information purposes only. It does not list, amend, extend, or otherwise alter the terms and conditions of insurance coverage contained in the Policy(ies) indicated below issued by ERIE. The terms and conditions of the Policy(ies) govern the insurance coverage as applied to any given situation.  Any party can request a policy and/or Declaration by asking the Insured or the Agent. Limits shown may have been reduced by claims paid.
--	--

**This is to certify that policies, as indicated by the Policy Number below, are in force for the Named Insured at the time that the Certificate is being issued.**

CO (Auto) LTR (Inst'l)	TYPE OF INSURANCE	POLICY NUMBER	POLICY EFFECTIVE DATE (MM/DD/YY)	POLICY EXPIRATION DATE (MM/DD/YY)	LIMITS														
D	<input type="checkbox"/> GENERAL LIABILITY <input checked="" type="checkbox"/> COMMERCIAL GENERAL LIABILITY <input type="checkbox"/> CLAIMS MADE <input checked="" type="checkbox"/> OCCUR  GEN'L AGGREGATE LIMIT APPLIES PER: <input checked="" type="checkbox"/> POLICY <input type="checkbox"/> PROJECT <input type="checkbox"/> LOC	Q31 6920061	7/19/09	7/19/10	<table border="1" style="width: 100%; border-collapse: collapse;"> <tr><td>EACH OCCURRENCE</td><td style="text-align: right;">\$ 1,000,000</td></tr> <tr><td>FIRE DAMAGE (Any One Fire)</td><td style="text-align: right;">\$ 1,000,000</td></tr> <tr><td>MED EXP (Any One Person)</td><td style="text-align: right;">\$ 5,000</td></tr> <tr><td>PERSONAL &amp; ADV. INJURY</td><td style="text-align: right;">\$ 1,000,000</td></tr> <tr><td>GENERAL AGGREGATE</td><td style="text-align: right;">\$ 2,000,000</td></tr> <tr><td>PRODUCTS-COMP/OP AGG</td><td style="text-align: right;">\$ 2,000,000</td></tr> </table>	EACH OCCURRENCE	\$ 1,000,000	FIRE DAMAGE (Any One Fire)	\$ 1,000,000	MED EXP (Any One Person)	\$ 5,000	PERSONAL & ADV. INJURY	\$ 1,000,000	GENERAL AGGREGATE	\$ 2,000,000	PRODUCTS-COMP/OP AGG	\$ 2,000,000		
EACH OCCURRENCE	\$ 1,000,000																		
FIRE DAMAGE (Any One Fire)	\$ 1,000,000																		
MED EXP (Any One Person)	\$ 5,000																		
PERSONAL & ADV. INJURY	\$ 1,000,000																		
GENERAL AGGREGATE	\$ 2,000,000																		
PRODUCTS-COMP/OP AGG	\$ 2,000,000																		
D	<input type="checkbox"/> AUTOMOBILE LIABILITY <input type="checkbox"/> "ANY AUTO" (OWNED, HIRED, NON-OWNED) <input type="checkbox"/> OWNED <input type="checkbox"/> HIRED <input type="checkbox"/> NON-OWNED <input type="checkbox"/> GARAGE				<table border="1" style="width: 100%; border-collapse: collapse;"> <tr><td>BODILY INJURY (EACH PERSON)</td><td style="text-align: right;">\$</td></tr> <tr><td>BODILY INJURY (EACH ACCIDENT)</td><td style="text-align: right;">\$</td></tr> <tr><td>PROPERTY DAMAGE</td><td style="text-align: right;">\$</td></tr> <tr><td>BODILY INJURY AND PROPERTY DAMAGE COMBINED</td><td style="text-align: right;">\$</td></tr> </table>	BODILY INJURY (EACH PERSON)	\$	BODILY INJURY (EACH ACCIDENT)	\$	PROPERTY DAMAGE	\$	BODILY INJURY AND PROPERTY DAMAGE COMBINED	\$						
BODILY INJURY (EACH PERSON)	\$																		
BODILY INJURY (EACH ACCIDENT)	\$																		
PROPERTY DAMAGE	\$																		
BODILY INJURY AND PROPERTY DAMAGE COMBINED	\$																		
D	<input type="checkbox"/> EXCESS LIABILITY <input checked="" type="checkbox"/> OCCURRENCE  <input type="checkbox"/> RETENTION \$	Q31 6970011	7/19/09	7/19/10	<table border="1" style="width: 100%; border-collapse: collapse;"> <tr><td>EACH OCCURRENCE</td><td style="text-align: right;">\$ 4,000,000</td></tr> <tr><td>AGGREGATE</td><td style="text-align: right;">\$ 4,000,000</td></tr> <tr><td></td><td style="text-align: right;">\$</td></tr> <tr><td></td><td style="text-align: right;">\$</td></tr> </table>	EACH OCCURRENCE	\$ 4,000,000	AGGREGATE	\$ 4,000,000		\$		\$						
EACH OCCURRENCE	\$ 4,000,000																		
AGGREGATE	\$ 4,000,000																		
	\$																		
	\$																		
D	<input type="checkbox"/> WORKERS COMPENSATION & EMPLOYERS LIABILITY	Q92 1800517	8/18/09	8/18/10	<table border="1" style="width: 100%; border-collapse: collapse;"> <tr><th colspan="4" style="text-align: left;">STATUTORY</th></tr> <tr><td rowspan="3" style="text-align: center;">BODILY INJURY BY</td><td>ACCIDENT</td><td style="text-align: right;">\$ 100,000</td><td>EACH ACCIDENT</td></tr> <tr><td>DISEASE</td><td style="text-align: right;">\$ 500,000</td><td>POLICY LIMIT</td></tr> <tr><td>DISEASE</td><td style="text-align: right;">\$ 100,000</td><td>EACH EMPLOYEE</td></tr> </table>	STATUTORY				BODILY INJURY BY	ACCIDENT	\$ 100,000	EACH ACCIDENT	DISEASE	\$ 500,000	POLICY LIMIT	DISEASE	\$ 100,000	EACH EMPLOYEE
STATUTORY																			
BODILY INJURY BY	ACCIDENT	\$ 100,000	EACH ACCIDENT																
	DISEASE	\$ 500,000	POLICY LIMIT																
	DISEASE	\$ 100,000	EACH EMPLOYEE																
D	<input type="checkbox"/> OTHER Rented/Leased Equipment	Q31 6920061	7/19/09	7/19/10	50,000														

DESCRIPTION OF OPERATIONS/LOCATIONS/VEHICLES/EXCLUSIONS ADDED BY ENDORSEMENT/SPECIAL PROVISIONS

**CANCELLATION FOR NON-PAYMENT, CAUSE OR NAMED INSURED'S REQUEST:** When an automobile policy is cancelled, written notice will be mailed to the Certificate Holder. When any of the above described policies (other than automobile) are cancelled before the expiration date thereof, ERIE will endeavor to mail written notice to the Certificate Holder after the decision to cancel. Failure to mail such notice shall impose no obligation or liability of any kind upon ERIE, its Agents or representatives.

**CANCELLATION FOR SPECIAL CONTRACTS:** (If the box is checked, this Certificate involves a special contract and the following cancellation provisions apply.) When an automobile policy is cancelled, written notice will be mailed to the Certificate Holder. When any of the above described policies (other than automobile) are cancelled before the expiration date thereof, ERIE will endeavor to mail \_\_\_\_\_ days written notice to the Certificate Holder after the decision to cancel. Failure to mail such notice shall impose no obligation or liability of any kind upon ERIE, its Agents or representatives.

<b>CERTIFICATE HOLDER</b>	<b>ATTENTION CERTIFICATE HOLDER</b> If your firm is a Certificate Holder for other policies of this Insured, Certificates of Insurance for these other policies will be forwarded to you as soon as they are processed.  AUTHORIZED REPRESENTATIVE 
---------------------------	---

**BID BOND**

Alpha Contracting Inc ATIMA  
KNOW ALL MEN BY THESE PRESENTS, That we, the undersigned, Doug Hicks Electric Co Inc  
of Beckley WV, as Principal, and Erie Ins Property &  
Casualty of Erie, PA, a corporation organized and existing under the laws of the State of WV  
with its principal office in the City of Beckley, WV, as Surety, are held and firmly bound unto the State  
of West Virginia, as Obligee, in the penal sum of (\$ 4,819.00) for the payment of which,  
well and truly to be made, we jointly and severally bind ourselves, our heirs, administrators, executors, successors and assigns.

The Condition of the above obligation is such that whereas the Principal has submitted to the Purchasing Section of the  
Department of Administration a certain bid or proposal, attached hereto and made a part hereof, to enter into a contract in writing for  
State of West Virginia Department of Administration, Division of  
Natural Resources. Various Locales as Indicated by Order

NOW THEREFORE,

- (a) If said bid shall be rejected, or
- (b) If said bid shall be accepted and the Principal shall enter into a contract in accordance with the bid or proposal attached hereto and shall furnish any other bonds and insurance required by the bid or proposal, and shall in all other respects perform the agreement created by the acceptance of said bid, then this obligation shall be null and void, otherwise this obligation shall remain in full force and effect. It is expressly understood and agreed that the liability of the Surety for any and all claims hereunder shall, in no event, exceed the penal amount of this obligation as herein stated.

The Surety, for the value received, hereby stipulates and agrees that the obligations of said Surety and its bond shall be in no way impaired or affected by any extension of the time within which the Obligee may accept such bid, and said Surety does hereby waive notice of any such extension.

IN WITNESS WHEREOF, Principal and Surety have hereunto set their hands and seals, and such of them as are corporations have caused their corporate seals to be affixed hereunto and these presents to be signed by their proper officers, this  
22 day of April, 20 10

Principal Corporate Seal

Alpha Contracting Inc ATIMA  
Doug Hicks Electric Co Inc

(Name of Principal)  
By *Doug Hicks*  
(Must be President or Vice President)

Doug Hicks- President  
(Title)

Surety Corporate Seal

Erie Insurance Property & Casualty  
(Name of Surety)  
*Jandee Blankenship*  
Attorney-in-Fact

**IMPORTANT - Surety executing bonds must be licensed in West Virginia to transact surety insurance. Raised corporate seals must be affixed, a power of attorney must be attached.**



Erie  
Insurance®

ERIE INSURANCE  
PROPERTY & CASUALTY COMPANY  
ERIE, PA 16530  
POWER OF ATTORNEY

KNOW ALL MEN BY THESE PRESENTS: That ERIE INSURANCE PROPERTY & CASUALTY COMPANY, a corporation duly organized under the laws of the Commonwealth of Pennsylvania, does hereby make, constitute and appoint

----- Annetta Bryant, Cynthia Farrell and Sandra Blankenship -----

individually, its true and lawful Attorney-in-Fact, to make, execute, seal and deliver for and on its behalf, and as its act and deed: any and all bonds and undertakings of suretyship,

----- in a penalty not to exceed the sum of five hundred thousand dollars (\$500,000.00). -----

And to bind ERIE INSURANCE PROPERTY & CASUALTY COMPANY thereby as fully and to the same extent as if such bonds and undertakings and other writings obligatory in the nature thereof were signed by the appropriate officer of ERIE INSURANCE PROPERTY & CASUALTY COMPANY and sealed and attested by one other of such officers, and hereby ratifies and confirms all that its said Attorney(s)-in-Fact may do in pursuance hereof.

The Power of Attorney is granted under and by authority of the following Resolution adopted by the Board of Directors of ERIE INSURANCE PROPERTY & CASUALTY COMPANY on the 11th day of March, 2008, and said Resolution has not been amended or repealed:

“RESOLVED, that the President, or any Senior Vice President or Vice President shall have power and authority to: (a) Appoint Attorney(s)-in-Fact and to authorize them to execute on behalf of the Company, bonds and undertakings, recognizances, contracts of indemnity and other writings obligatory in the nature thereof, and, (b) Remove any such Attorney-in-Fact at any time and revoke the power and authority given to him; and

RESOLVED, that Attorney(s)-in-Fact shall have power and authority, subject to the terms and limitations of the Power of Attorney issued to them, to execute and deliver on behalf of the Company, bonds and undertakings, recognizances, contracts of indemnity and other writings obligatory in the nature thereof. The corporate seal is not necessary for the validity of any bonds and undertakings, recognizances, contracts of indemnity and other writings obligatory in the nature thereof.”

This Power of Attorney is signed and sealed by facsimiles under and by virtue of the following Resolution adopted by the Board of Directors of ERIE INSURANCE PROPERTY & CASUALTY COMPANY on the 18th day of September, 2008, at which a quorum was present and said Resolution has not been amended or repealed:

“RESOLVED, that the signature of Terrence W. Cavanaugh, as President and Chief Executive Officer of the Company, and the Seal of the Company may be affixed by the following facsimiles on any Limited Power of Attorney for the execution of bonds, undertakings, recognizances, contracts and other writings in the nature thereof, and the signature of James J. Tanous, as Secretary of the Company, the Seal of the Company, the signature of Sheila M. Hirsch, as Notary Public, and her Notarial Seal, may also be affixed by the following facsimiles to any certificate or acknowledgment of any such Limited Power of Attorney, and only under such circumstances shall said facsimiles be valid and binding on the Company.”

IN WITNESS WHEREOF, ERIE INSURANCE PROPERTY & CASUALTY COMPANY has caused these presents to be signed by its President and Chief Executive Officer, and its corporate seal to be hereto affixed this 18th day of September, 2008.

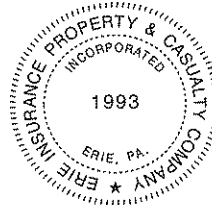

*Terrence W. Cavanaugh*  
Terrence W. Cavanaugh  
President and Chief Executive Officer

STATE OF PENNSYLVANIA } ss.  
COUNTY OF ERIE

On this 18th day of September, 2008, before me personally came Terrence W. Cavanaugh, to me known, who being by me duly sworn, did depose and say: that he is President and Chief Executive Officer of ERIE INSURANCE PROPERTY & CASUALTY COMPANY, the corporation described in and which executed the above instrument; that he knows the Seal of said corporation; that the Seal affixed to the said instrument is such corporate Seal; that it was so affixed by order of the Board of Directors of said corporation and that he signed his name thereto by like order.

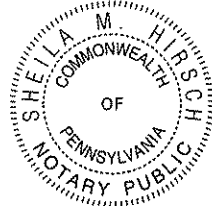

*Sheila M. Hirsch*  
My commission expires June 27, 2012  
Notary Public

CERTIFICATE

I, James J. Tanous, Secretary of ERIE INSURANCE PROPERTY & CASUALTY COMPANY, do hereby certify that the original POWER OF ATTORNEY, of which the foregoing is a full, true and correct copy, is still in full force and effect as of the date below.

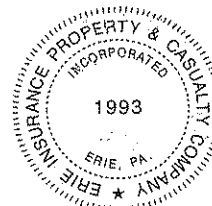

*James J. Tanous*  
James J. Tanous Secretary

In witness whereof, I have hereunto subscribed my name and affixed corporate Seal of the Company by facsimiles pursuant to the action of the Board of Directors of the Company,

this 22<sup>nd</sup> day of Apr. 20 10



State of West Virginia  
DRUG FREE WORKPLACE CONFORMANCE AFFIDAVIT  
West Virginia Code §21-1D-5

STATE OF West Virginia  
COUNTY OF Raleigh, TO-WIT:

I, Travis Hicks, after being first duly sworn, depose and state as follows:

- 1. I am an employee of Alpha Contracting Inc.; and,  
(Company Name)
- 2. I do hereby attest that Alpha Contracting Inc  
(Company Name)

maintains a valid written drug free workplace policy and that such policy is in compliance with **West Virginia Code §21-1D-5.**

The above statements are sworn to under the penalty of perjury.

Alpha Contracting Inc.  
(Company Name)

By: Travis Hicks  
Title: C.O.O.  
Date: 4/21/10

Taken, subscribed and sworn to before me this 21 day of April 2010  
STATE OF WEST VIRGINIA  
NOTARY PUBLIC  
By Commission expires Oct. 29 2017



136 Chestnut Avenue  
Oakhill, WV 25901  
My Commission Exp. Oct. 29, 2017

Kimberly Gil  
(Notary Public)

**THIS AFFIDAVIT MUST BE SUBMITTED WITH THE BID IN ORDER TO COMPLY WITH WV CODE PROVISIONS. FAILURE TO INCLUDE THE AFFIDAVIT WITH THE BID SHALL RESULT IN DISQUALIFICATION OF THE BID.**