

SILLING
ARCHITECTURE PLANNING INTERIORS

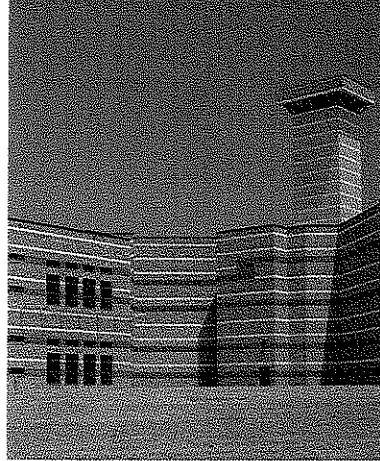
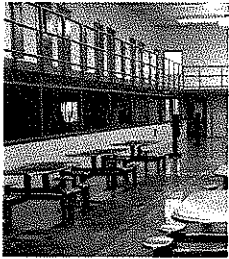

EXPRESSION OF INTEREST
Davis Center Renovations
WV Division of Juvenile Services
RFQ #DJS010291

RECEIVED

2010 MAY 13 AM 11:51

WV PURCHASING
DIVISION

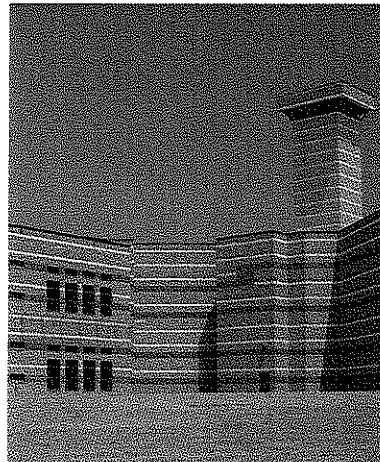
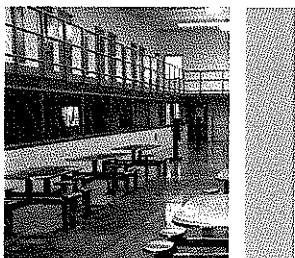

EXPRESSION OF INTEREST
Davis Center Renovations
WV Division of Juvenile Services
RFQ #DJS010291



Table of Contents

TAB 1	Cover Letter
TAB 2	Introduction of the Design Team Overview of Experience
TAB 3	Silling Associates Architecture
TAB 4	Scheeser Buckley Mayfield MEP Engineering
TAB 5	Shelley Metz Baumann Hawk Structural Engineering
TAB 6	GAI Consultants Civil/Site Engineering





SILLING

ASSOCIATES • ARCHITECTS

405 Capitol Street, Upper Atrium
Charleston, WV 25301-1727
p 304.346.0565 f 304.346.1522
email: info@silling.com

May 11, 2010

Ms. Krista Ferrell
Purchasing Division
2019 Washington Street, East
Charleston, West Virginia 25305-0130

Re: RFQ #DJS010291

Dear Selection Committee Members:

Silling Associates, Inc. is pleased to submit an Expression of Interest to provide complete architectural/engineering design and construction administration services to the Division of Juvenile Services for the Davis Center project. We offer the Division of Juvenile Services the most professional and experienced team of correctional facility design professionals in the state of West Virginia.

Silling Associates Incorporated is the longest continuing architectural practice in West Virginia with origins dating to the early 1900s. We offer an unparalleled experience working with the Division of Corrections, Division of Juvenile Services, and the Regional Jail and Correctional Facility Authority, including work at eight major facilities totaling over 1 million square feet and 2,200+ beds of new construction, renovation, and adaptive reuse projects. This design experience includes the Industrial Home for Youth, Mount Olive Correctional Complex, St. Marys Correctional Center, Huttonsville Correctional Center, Stevens Correctional Facility, Martinsburg Correctional Center, and Pruntytown Correctional Center, to name a few.

Complimenting the architectural team will be **Scheeser Buckley Mayfield**, consulting mechanical/electrical/plumbing engineers; **Shelley Metz Baumann Hawk**, consulting structural engineers; and **GAI Consultants**, consulting civil/site engineers. These design professionals have routinely served as Silling Associates' engineering and consulting team members and provide a carefully orchestrated, seamless approach to the design process.

Overall, Silling leads a design team comprised of more than one hundred design professionals with significant principal involvement, who will be dedicated to the successful design of the Davis Center Renovation project. We offer an extensive background in correctional facility design, an intimate understanding of state juvenile facility operations, a creative and appropriate design approach grounded in the need for efficiency, economy, and security, rigorous attention to construction detail, and responsible administration of the construction contract.

We have enclosed a summary of our Design Team's qualifications for your review. We look forward to discussing our experience and approach to the Davis Center project in greater detail.

Sincerely,



Thomas M. Potts, AIA
President

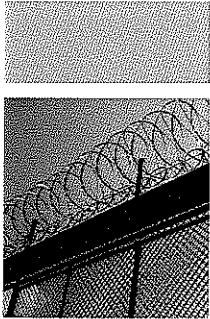

INTRODUCTION

The design team led by **Silling Associates** represents an outstanding assembly of firms, all with a record of design excellence, management skill and technical expertise. As a seamless force, we bring a unique familiarity to the state's correctional system and its facilities, we exhibit a history of design virtuosity, and we possess a vast range of experience in correctional design and major building renovation and rehabilitation work. Working with the Division of Juvenile Services, we bring the potential of realizing well-coordinated, well-designed, and a well-built project at the Davis Center.

Silling Associates IS THE LONGEST CONTINUING ARCHITECTURAL PRACTICE IN WEST VIRGINIA originating in 1902. Many of our state's most notable buildings are the result of the efforts of our predecessors. Today we are recognized as the correctional design leader in the state and we continue the firm's tradition of high quality design and project management. Silling Associates offers the Division of Juvenile Services local presence, accountability and high quality client service in the successful delivery of multiple design and renovation projects throughout the state. As the local anchor-design team member, we are excited about the extraordinary qualifications of our team and the possibility of continuing to enhance West Virginia's juvenile correctional facilities that we so highly value.

We have long been recognized for our quality of work, project coordination and management, and our ability to handle multiple projects throughout the state of West Virginia. We have most recently managed design and construction projects in Martinsburg, Berkeley Springs, Huttonsville, and Welch, as well as projects in Maryland, Ohio, Kentucky, and Pennsylvania.

We also offer a proven understanding of all applicable State Federal, and ACA codes and regulations while also maintaining an excellent working relationship with the State Fire Marshal's office.

In summary, our correctional planning and design experience covers projects of all sizes, scope and complexity including new construction, large- and small-scale renovations, and adaptive reuse. Our work within the state of West Virginia includes the **Industrial Home for Youth, Mount Olive Correctional Complex**, various expansion and renovation projects at **Huttonsville Correctional Center**, the conversion of a former hospital creating the **Stevens Correctional Facility**, renovations to **Martinsburg Correctional Center, St. Marys Correctional Center**, four Work Release/Training Centers for the **WV Division of Corrections**, a women's maternity unit at **Lakin Correctional Center**, and renovations to **Pruntytown Correctional Center**, among others.



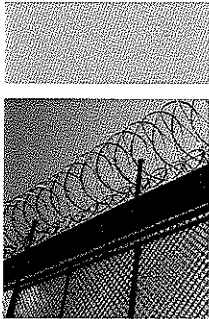

THE DESIGN TEAM

The Project Team offers the full spectrum of services required for the Davis Center project which will include the following disciplines:

- Project Programming
- Architectural Design
- Interior Design /Furniture Fixtures and Equipment Design
- Civil Engineering
- Geotechnical Engineering
- Mechanical Engineering
- Electrical Engineering
- Food Service and Laundry Design
- Communications and Electronic Security Design
- Construction Contract Administration

The team is led by **Silling Associates, Inc.** as the Project Manager, Designer, and Construction Administrator. Silling will be responsible for all communications with the Division of Juvenile Services; project budget development; programming; architectural design; design schedule; and quality assurance. All phases of the architectural design; i.e., schematic design, design development, and contract documents will be developed by the staff of this office.

The other team members indicated will provide the required engineering support and the work will be accomplished in each firm's home office. All firms have significant presence and experience in West Virginia and are extremely familiar with ACA guidelines, the state's applicable building codes, traditional methods of construction, as well as purchasing and contracting requirements. As will be seen, each has a history of experience with secure facility design involving all levels of inmate security and building classifications.

The Team brings to the table both design continuity and stability, as well as the resources of each individual firm. Each team member has significant experience with project collaboration, having worked together for more than a decade on numerous projects throughout the state. We estimate more than 20 licensed design professionals will have significant assignment to the Davis Center project. Additionally, each firm brings to the project significant support staff, including CAD operators experienced in their respective disciplines.

Team members share a common design tradition that is focused on "*design excellence.*" The end result is achieved through a mutual acceptance of responsibility; a methodical step-by-step approach to all phases of the project; effective and timely communication; and a rigorous attention to value.

This Expression of Interest outlines the experience of each member firm and includes the resumes of key personnel assigned to the project.



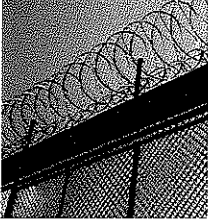

KEY PERSONNEL

ARCHITECTURE

Thomas Potts, AIA; President, Silling Associates
Jody S. Driggs, AIA, Principal, Silling Associates
Sean Simon, AIA; Silling Associates
Jason Rutledge, Assoc. AIA, Silling Associates

Principal in Charge
Project Support
Construction Period Manager
Production Coordinator

MEP ENGINEERING

Jim Eckman, PE, LEED AP; President, SBM
Mike Wesner, PE, LEED AP; Principal, SBM

Electrical Engineering
Mechanical Engineering

STRUCTURAL ENGINEERING

Bob Baumann, PE; President, SMBH

Structural Engineering

CIVIL/SITE ENGINEERING

James Hemme, PE; Senior Project Manager, GAI

Civil Engineering

ORGANIZATIONAL CHART

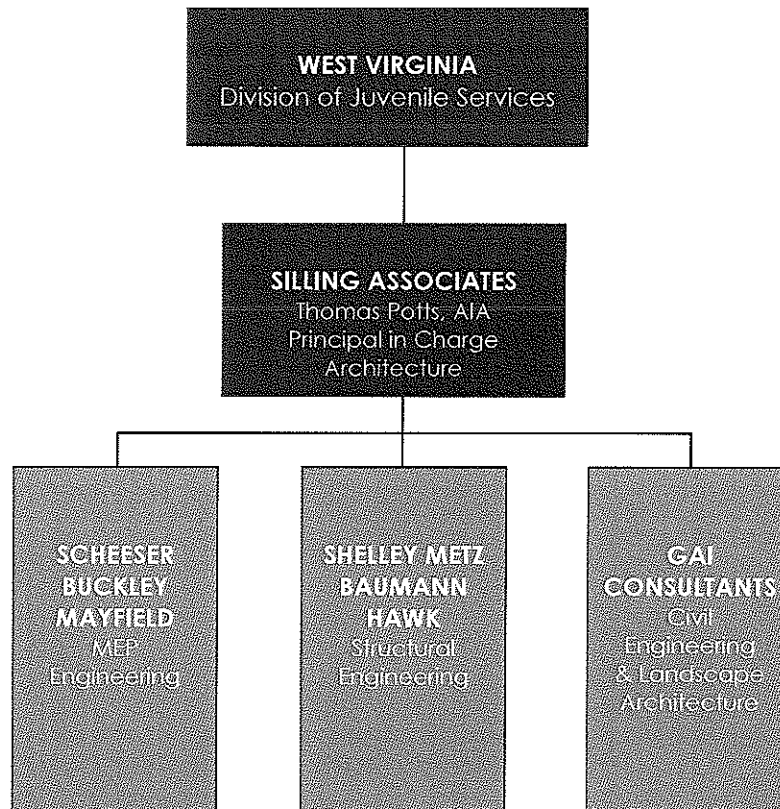

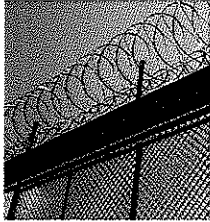

ROLES & RESPONSIBILITIES

Silling Associates Incorporated

Silling Associates Incorporated will be the **Architect of Record**, maintaining and facilitating effective communication and coordination with the WV Division of Juvenile Services, the Design Committee, and the team of consulting engineers. Silling Associates will maintain overall project responsibility throughout each phase of the project, including:

- Programming
- Schematic Design
- Design Development
- Project Budget
- Design Schedule
- Document Production
- Bidding & Negotiating
- Construction Contract Administration

Mr. Tom Potts, president of Silling Associates, with 22 years' experience in project design and production, will be the Principal-in-Charge with final design team authority.

Scheeser Buckley Mayfield

Scheeser Buckley Mayfield, **mechanical/electrical Engineers**, will become actively involved in the design effort midway through schematic design. Mike Wesner, PE, lead mechanical engineer, with 23 years' experience, and James Eckman, lead electrical engineer, with 22 years' experience, will then develop design concepts based on the various parameters set forth by Silling and begin to integrate Mechanical/Electrical/Plumbing solutions coordinated within the building structural and architectural system. They will provide critical cost and value engineering input to Silling as the process deepens. During construction documentation, they will finalize design drawings, continuing to evaluate budget information and focus on interdisciplinary systems coordination.

Shelley Metz Baumann Hawk

Shelley Metz Baumann Hawk, **structural engineer**, will become involved from the initial steps in the design. Parallel with the programming process, site analysis will involve some preliminary subsurface investigation to provide rough foundation concepts with preliminary budget input. Midway through the schematic design, they, like Scheeser Buckley Mayfield, will begin to have increased involvement with Silling as design development concepts unfold. During this phase they will support Silling with critical value engineering input and their expertise of regional construction methods will be beneficial to the overall project budget. They will continue to work with Silling Associates during construction documentation as details become finalized and interdisciplinary reviews are performed and specifications are developed.

GAI Consultants

GAI Consultants will provide **civil engineering** and **landscape architecture** services for the project and will be led by James Hemme, PE, and David Gilmore, ASLA.



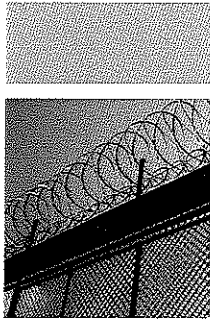

RESOURCES AND RESPONSIVENESS

With a team of fifteen architects, designers, production staff, and administrative support, Silling Associates has consistently proven itself capable of delivering a large volume of work annually, both in terms of numbers of projects as well as individual project size, scope, and complexity. Silling ensures principal involvement in all projects which is fostered within a studio environment, allowing our firm to build multiple-person teams within the office to focus on a variety of projects simultaneously. Likewise, open sharing of project information, project status, and large picture scheduling of our workload allow architects, designers, and technicians to be informed on a number of current project needs and deadlines and cross-pollinate from job to job and task to task. It is this efficiency and teamwork that is fundamental to our ability to service the number of very satisfied clients that we are fortunate to have.

However, it is primarily a culture of service that permeates everything that Silling does and leads to very satisfied clients. Aggressive communication is an axiom of our firm, and the heart-felt desire to be highly responsive to client needs and demands has proven to be one of the many reasons that owners select Silling Associates. This is most obvious in the number and references of our many repeat clients across the state, particularly with the state correctional system.

Regarding the cost effectiveness with which we can provide design services for WVDJS, our firm remains extremely efficient, once again, due to principal involvement. As owners of the firm, the partners at Silling are actively engaged as work-producing project managers surrounded by a highly talented and effective group of project managers and designers. We employ an aggressive and talented team and impress each of our clients with the speed with which we can arrive at thorough and engaging concepts. Non-billable overhead is kept low through work-producing partners, and talented design staff empowered by the latest in design technology and software allow us to consistently outperform both large-scale national firms and under-powered smaller competitors. We pride ourselves on delivering design excellence within the most competitive fee structures, which is evidenced by over a century of consistent practice and perpetual line of prospective clients eager to get the absolute best design service for their cost. You will find that the hourly rates of our firm partners, architects, managers, and technicians are highly competitive, and we are geared to be a very lean and productive team with extensive capacity to handle the Davis Center project efficiently and effectively.

FAMILIARITY & EXPERIENCE

Silling Associates offers an appropriate familiarity with the WV Division of Juvenile Services leadership and the state's correctional system, key facilities managers, and administrative personnel. These relations, in addition to our unique understanding of correctional facility design, project management and coordination, have resulted in a number of highly successful correctional facility projects throughout the state.



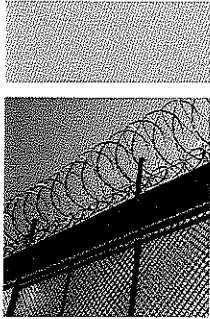

PROJECT APPROACH

Moving forward, we are prepared to assist the WVDJS in developing a highly functional and secure female residential facility in Davis, West Virginia. Working in close collaboration with DJS and key Davis Center leadership, Silling will provide the following services in a timely and efficient manner:

- Verification of the Building Program
- Assessment of the existing building inventory
- Recommendations for building demolition
- Building improvement needs (including architectural, mechanical, electrical, plumbing, telecommunications, and fire protection systems)
- Physical and electronic security
- Food service and laundry
- Health and life safety upgrades
- ADA improvements (site and building)
- Site improvements (site-related infrastructure, parking, security, etc.)
- Conceptual site and building floor plans, elevations, and renderings
- Project cost estimating & budget management
- Development of construction documents
- Furniture, fixtures, & equipment specification
- Bidding and negotiating
- Construction contract administration
- Project close-out

Given the nature of our state's economy and potential limitations on project funding, Silling will approach the Davis Center project with great attention to functionality, cost, and quality while delivering a safe and secure female residential facility for the WVDJS.

Over the last ten years, the Division of Corrections has routinely called on Silling to meet some of the most challenging renovation and adaptive reuse projects, often involving dated buildings with critical deficiencies and limited construction budgets, and ultimately requiring highly technical and creative problem solving to meet the needs of our state's correctional system. Similarly, Silling offers the very same level of commitment, expertise, and service to the Division of Juvenile Services for this very important project.





SUMMARY OF QUALIFICATIONS

Resources

Silling Associates offers the WV Division of Juvenile Services one of the most talented and resourceful correctional design firms in the state of West Virginia. Our staff of fifteen serving the architectural disciplines include two principal architects, a senior associate architect, a construction period manager (licensed architect), project managers and designers, interior designers, CAD technicians, and administrative staff members. Our team of consulting engineers provide an additional 80+ design professionals serving the mechanical, electrical, plumbing, telecommunications, structural, and civil engineering disciplines. In total, we offer exceptional resources to effectively manage the Davis Center Renovation project.

Project Leadership

The WVDJS will receive PrincipaHed project management across all design disciplines from project conception through completion. Mr. Tom Potts, serving as your Project Executive, will assume comprehensive responsibility for the entire project including overall project management, architectural design, coordination of the engineering team, and direct communication with you, the owner.

Project Collaboration

Each of the Design Team members share extensive collaborative experience together, which facilitates a highly technical, yet seamless approach to the successful integration of architectural and engineering systems. Rather than employing only a handful of in-house engineers, Silling (and your project) have access to an expansive engineering team that brings a wealth of diverse project experience, technical capabilities, and talent.

Direct Experience

Silling Associates and the Design Team offers a diverse level of experience that is well-suited for the Davis Center project. This experience includes over 1.5 million square feet and approximately 2,500 beds for the WV Division of Corrections, WV Division of Juvenile Services, and the WV Regional Jail and Correctional Facility Authority.

Commitment

Silling Associates and our Design Team are truly excited to build upon our long and rich history serving the state's correctional system, continuing a long-standing partnership by providing our services with extraordinary care and diligence, exceptional leadership, and an unwavering commitment to complete client satisfaction. While we are very proud of the architectural solutions we have sought in partnership with our clients, we are most proud of the level of service we have provided and, more importantly, humbled by the level of trust we have earned from the people we serve. We believe you will see and hear from our references that we are committed to client service and work very hard to exceed every expectation of our projects, and that we are called on repeatedly by the people for which we work. Furthermore, you will see that our firm has an incredibly broad range of experiences and has earned a reputation as problem solvers with a unique combination of research skills and creative thinking required to develop something meaningful yet cost effective. Working within the West Virginia marketplace, we are accustomed to maintaining strict design schedules and budgets and are routinely charged with doing more for less. We look forward with great anticipation to the opportunity to interview before your Committee and further outline our specific approach to the Davis Center project.



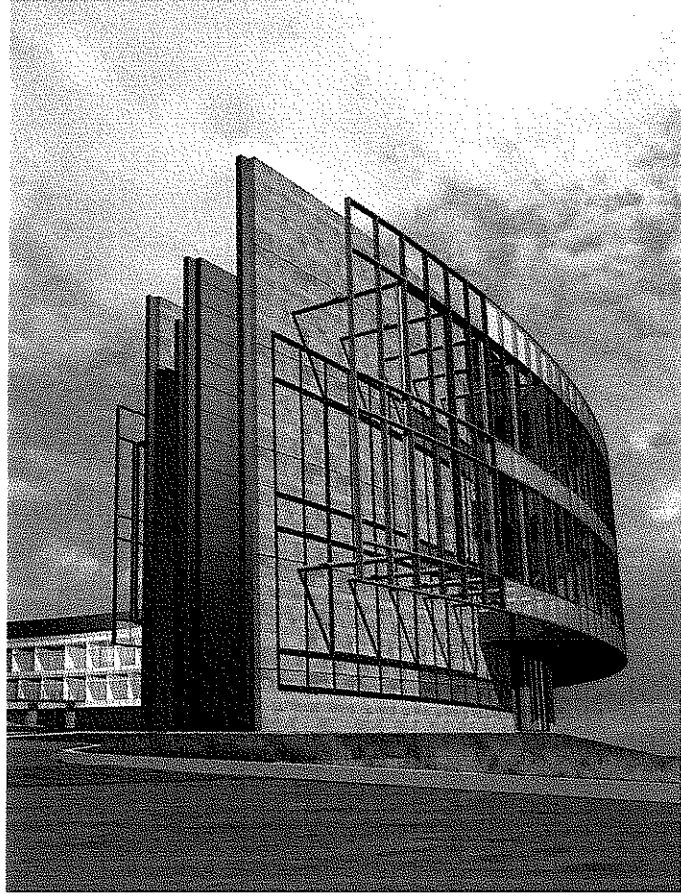
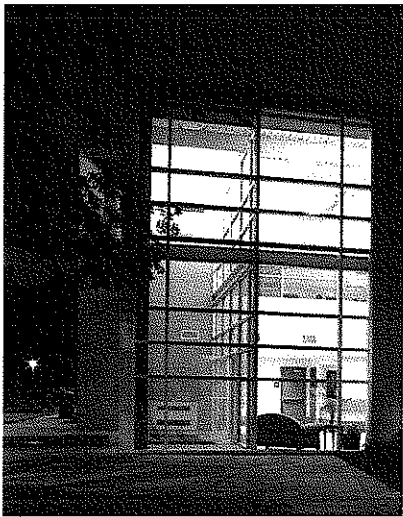

About SILLING ASSOCIATES

Architectural success is measured by vision and an unwavering dedication to excellence. This axiom was the philosophical birth of Silling Associates Incorporated by H. Rus Warne in 1902. Following the lead of partners like Warne and its namesake, Cy Silling, the firm today has the proud distinction of being the oldest continuing architectural firm in West Virginia and one of the oldest in the eastern United States. Throughout, Silling Associates has woven itself into the very fabric of West Virginia, providing planning and architectural services that have touched the lives of virtually every citizen and delivering landmark projects collectively defining its built environment.

Whether through its early century beaux arts and neo-classical collection, its mid-century modern and post-modern portfolio, or its current contextual vocabulary, Silling has always been renowned as one of the premier architectural firms in the state. Today, Silling Associates continues to have a powerful impact on the region's architectural landscape through fresh, yet solid design and responsible project management.



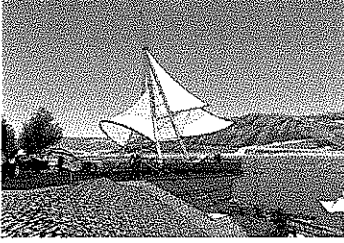

DESIGN Philosophy

At Silling, design drives everything that we do in architecture, planning and interiors. We believe that design fulfills and propels each client's goals and aspirations; that design articulates spaces to new levels of effectiveness; that design engages, inspires and fulfills; and that design elevates the human experience.

We begin each project by listening to our client. We listen to understand a client's vision, goals and objectives. We believe the concept of design in architecture applies not only to sketches, plans, specifications, and the building process, but to every aspect of the project. We design each project in a synthesis of everything that we heard from a client, and of our own professional design expertise—working collaboratively and uniting all professional disciplines in the process to create truly integrated design solutions. We deliver each project with responsive service and technical excellence to the complete satisfaction of our client, which is the ultimate measure of our success. This is why you can depend on Silling to walk you through every phase of the process.

From our firm's inception over 100 years ago, Silling has remained committed to four essential principles: listening to the needs of our clients, understanding the challenges they face, solving their problems, and producing high quality results. These guiding principles are contributing factors to the foundation and success of every project Silling undertakes. We are dedicated to providing outstanding analysis, planning, design, and construction for every one of our projects.



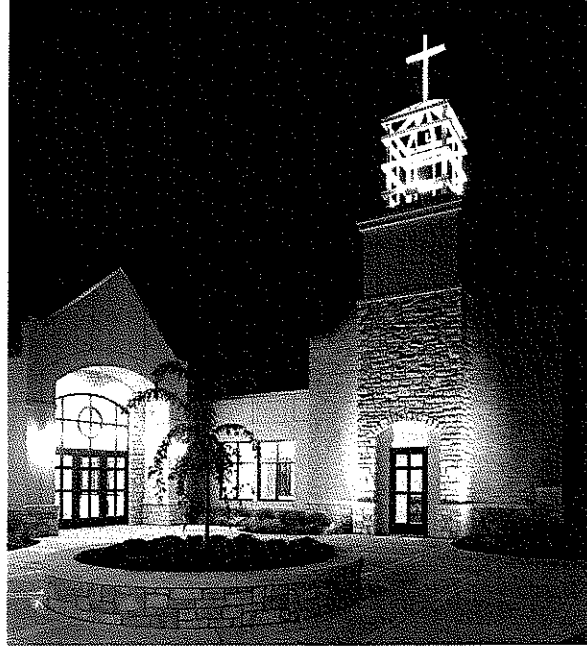
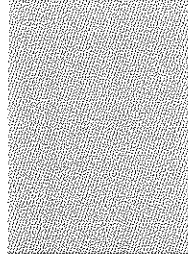

ORGANIZATIONAL Structure

Silling Associates is a principal-led design practice, and the organizational structure of our firm is very much studio-oriented. The principals of our practice are actively engaged in all projects and routinely serve as daily project managers for all major design commissions. This structure ensures that first-hand project criteria, relayed directly from clients in programming and design review meetings, is directly applied to all work within the office; from conceptual design through construction detailing, specification writing, and construction observations services. Likewise, through this studio environment structure, all the talents and perspectives of the entire design and production staff at Silling are brought to each design task, allowing our firm to build multiple-person teams within the office to focus on a variety of projects simultaneously. Likewise, open sharing of project information, project status, and large picture scheduling of our workload allow architects, designers, and technicians to be informed on a number of current project needs and deadlines and cross-pollinate from job to job and task to task. This highly interactive and collaborative structure yield compelling design solutions, maintains client expectations throughout the process, and most importantly ensures quality through principal leadership.

However, it is primarily a culture of service that permeates everything that Silling does and leads to very satisfied clients. Aggressive communication is an axiom of our firm, and the heart-felt desire to be highly responsive to client needs and demands has proven to be one of the many reasons that owners select Silling Associates. This is most obvious in the number and references of our many repeat clients across the state.



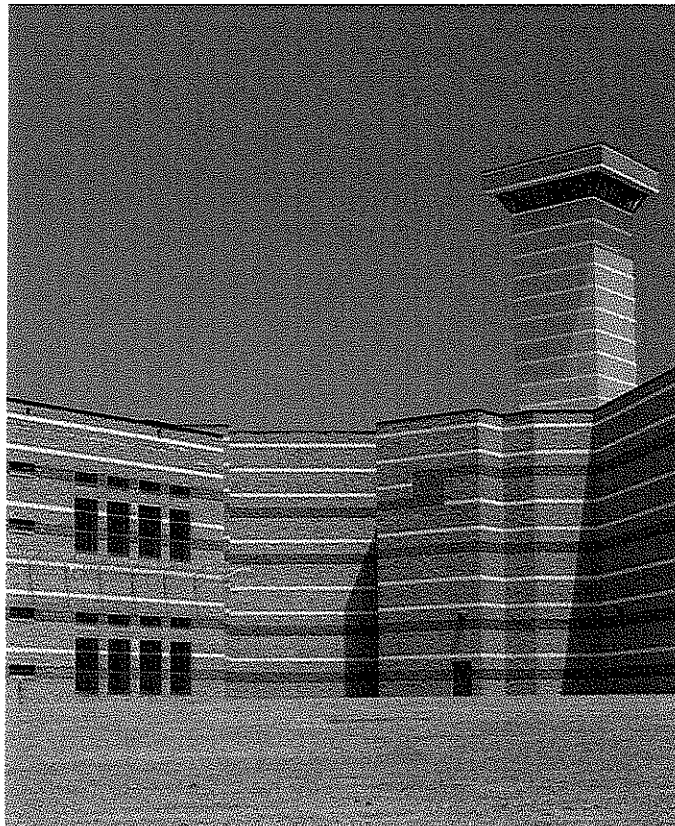
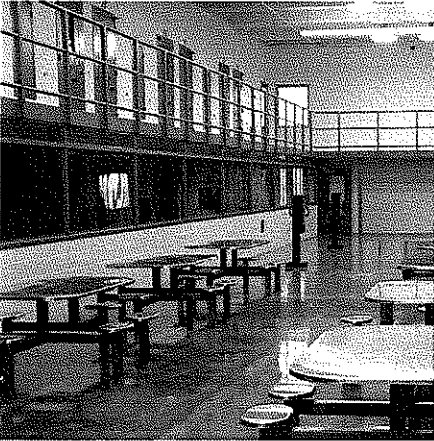

Correctional DESIGN LEADERSHIP

In the late 1930s, the original Huttonsville Correctional Center was completed and began housing inmates for the State of West Virginia's prison system. This facility, still in operation today, was designed by Tucker and Silling, now known as Silling Associates, Incorporated.

Today, Silling remains a trusted leader in providing architectural design services for many of our state's correctional institutions. Within the last twenty years alone, Silling Associates has completed over 1.5 million square feet of correctional facility work totaling over 2,500 beds throughout the state of West Virginia. Our experience with both juvenile and adult correctional facility designs have provided housing and rehabilitative services for the state's low, medium, and maximum security population via new construction, addition and renovation, and adaptive reuse projects of all sizes, complexities, and budgets.



Our Services

INTRODUCTION

Today's dynamic marketplace demands versatility of the design professional. Silling Associates is structured to meet the needs of design/build, construction management, and the traditional design/bid/build delivery methods. Technology has driven the demand for increased design specialization. Collaboration and consensus are principles that are critical to the success of a project. Our staff has a track record of successful projects created both independent of, and in concert with, the most talented professionals within a given building type and engineering discipline. We are committed to delivering quality through understanding the nature of the project and composing the appropriate talents to achieve design excellence.

FEASIBILITY STUDIES

When an owner is exploring the possibility of, or is seeking justification for, a given project they turn to an architect to provide this service. Over the years, Silling has been called upon to assist numerous clients in making decisions relative to the development of a project.

Our first assignment involves the assimilation of information regarding a client's wants and needs and the general scope of the project being considered. It is from this data that we glean important facts that constitute the basis of our study.

An outline is prepared; ideas and concepts which we deem workable are considered and developed; and associated costs are computed. The result is a finished product which allows the owner to effectively weigh the pros and cons of a proposed project and make an educated judgment as to its feasibility.

MASTER PLANNING

Silling Associates is well-respected throughout the industry for its insightful, viable planning services. Over our storied history, Silling has prepared Master Plans for the State Capitol Complex, various institutions for higher education, regional medical centers, courthouse campuses, worship centers, as well as corporate offices, to name a few.

Our Master Plans feature a thoughtful blend of functionality and aesthetics—cost-conscious solutions which fit a client's expressed criteria. The process begins with an overview of the site—defining its parameters; determining site conditions both above and below ground; and assessing existing structures. Taking these factors into consideration, our design experts go to work committing their vision to a three-dimensional computer-generated image of the project. It is this methodology which allows the client an opportunity to "visit" the site and take a virtual tour of the project.

Silling's successful ongoing relationships with our clients serve as testament to our success in assisting them in developing successful strategies and accurate assessments of their existing facilities to both determine their current needs and define their future goals.



Our Services

PROGRAMMING

Exploration of the building concept is but a single element in the steps of the design process. Silling Associates utilizes a proven Design Approach Method that permits a high degree of interaction from the facility's end-users at every level of design.

During programmatic workshops, we begin with documentation, which indicates general building considerations, proposed building sites, and lists each required space with its relative required square footage. We analyze proposed sites and make appropriate recommendations. We seek to identify the broader issues of circulation, function, building image, and project budget. The programmatic requirements are the point of departure for the generation of both a two- and three-dimensional design solution. The internal circulation structure becomes the organizing element—the backbone for the alignment of space. Departments are grouped. Commonality and order are sought with the structural and mechanical systems in mind. The arrangement of components with respect to security, public arrival, departmental flow, relationship to natural light, and code-required egress are all explored. The relationship to the site is considered, orientation to the sun, to views, parking, and other site amenities are incorporated. Silling utilizes sophisticated three dimensional computer modeling as a vehicle to realistically study the variety of options that arise. This modeling tool provides the client a real ability to visualize and make sound design choices.

SCHEMATIC DESIGN

For over a century, Silling has delivered exceptional architectural services to an immensely diverse clientele. The commonality of our work is not depicted in any particular architectural style or design vocabulary. Rather, our work is about a great appreciation of people — those people that entrust in us the responsibility of creating space through the investment of human and financial resources. We hope that our designs resemble who they are, and hope that our services are delivered with a care that resembles our client relationships.

Through a proven Design Approach methodology, we begin the design's development with further analysis of the proposed site. We routinely explore iterations of the preferred concept to perfect the space planning, site planning and ideas for exterior expression. Development of building floor plans result in a depiction of the arrangement of all of the functional components, the illustration of the building circulation, and the detail indicating the size and relationship of all spaces. The process then includes the development of the site plan to include pedestrian and vehicular site circulation, topography, site features and utilities. Three-dimensional models and video animation are typically developed to best convey the building and its features in site context.

The Schematic Design phase is a process of design proposal, review with the client, and the consideration of design alternatives to achieve the highest degree of functionality and expression while developing consensus.



Our Services

DESIGN DEVELOPMENT

The Design Development phase is focused on the selection of building materials and systems and continues to involve uncovering the needs of the end-user(s). Design reviews are held generally on a biweekly basis with the appropriate groups and input into the design is documented. The architectural and engineering team pay particular attention to the quality of the design, its documentation, and agreement with the original goals detailed in the workshop process. Selections are tested against the overall project budget. Value engineering and choices are made, if necessary, to align project scope against costs. Code officials are included in the design process to build consensus and eliminate future potential surprises, and a formal quality control group begins their evaluation of generated documents. Drawings and specifications are reviewed for agreement with recognized standards of detailing and documentation. Specifications are evaluated for alignment with drawings and their ability to generate competitive bids

INTERIOR DESIGN

Over the years, Silling Associates has accumulated a substantial portfolio of projects for a wide variety of building types, sizes, and complexities. The firm has a particular strength in defining client needs for interiors planning, function, feasibility, and image – both in new construction and renovation projects.

We offer a comprehensive list of interior design services including:

- Space Planning - Furniture & Accessories Design
- Conceptual Design - Furniture Specifications
- Strategic Consulting - Purchasing Coordination
- Adaptive Reuse - Budget Planning

Our clients routinely call on us to create interior environments that will enhance the performance of their products, services, staff, and visitors. Our talented interior designers have an ability to provide numerous design solutions and alternatives for virtually every project type and budget.

SUSTAINABILITY & LEED CERTIFICATION

The environments where our clients live, work, and play impacts discovery and changes lives. At Silling, this is a responsibility that we take very seriously. Good design and sustainability should work together to result in increased building efficiency, improves users' health and productivity, conserves the Earth's resources, and reduces operational and maintenance costs. A building should wear its sustainability not only as a demonstration serving to inspire those who interact with the facility, but also as a model of achievement for the community. Our approach to creating sustainable buildings begins with the following core design principles: optimal use of the site, use of non-renewable energy consumption, use of environmentally preferable products, conservation of water, enhancement of indoor air quality, and optimization of operational and maintenance practices.



Our Services

Our team of LEED-accredited design professionals provide leadership in defining sustainable planning initiatives for each project, implementing sustainable strategies, and working through the LEED Certification process. As a member of the United States Green Building Council (USGBC), we are committed to creating environmentally and economically effective buildings for our clients and communities.

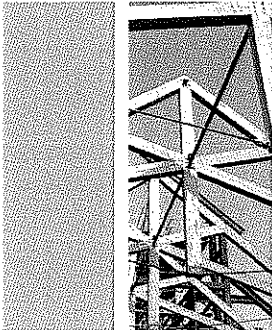

CONSTRUCTION PERIOD MANAGEMENT

Pre-construction meetings are facilitated by the design team and a clear definition of project goals and owner's expectations are verbalized. Submittals, product samples, and shop drawings are thoroughly reviewed for conformance to the contract drawings and specifications. Throughout construction, designer and owner's representatives attend weekly or biweekly progress meetings to maintain clear communication with builders and continually monitor the project schedule.

In addition, architects and engineers periodically visit the construction site to observe installation of materials and systems and to verify their conformance with the design intent. Contractor's pay applications are reviewed and approved by the designers to ensure a fair disbursement of the total construction cost.

We conduct final inspections upon substantial completion and routinely assist in the occupancy of the facility by the owner.

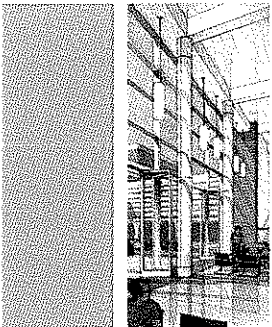

PROJECT DELIVERY

Many clients today are faced with the difficult decision of how to develop their project. A major capital building program involves important decisions regarding the method by which the projects will be designed and constructed - the project delivery method. This decision has become more complex as a variety of alternative delivery methods have been developed in addition to traditional design-bid-build process. Methods that have gained in popularity include fast-track construction, multiple prime contracting, and design-build. Though each of these delivery methods offers its share of positive attributes to project developers, there are inherent "risks" and potential shortfalls as well. Issues such as competitive pricing versus guaranteed maximum pricing, project schedule, single/multiple source responsibility, change orders, owner liability, and quality control must all be considered prior to choosing the RIGHT delivery method for you.

In addition to our long and successful record of managing design-bid-build projects, Silling Associates has considerable experience in successfully delivering a diverse mix of building projects, large and small, in some of the newest, most collaborative construction delivery models in the marketplace in concert with many of the region's leading general contractors and design builders.

We encourage you to call on the experienced leaders at Silling to "walk" you through the project delivery evaluation process and help you make the RIGHT decision for your project.





Thomas M. Potts, AIA

Principal

Professional Bio

Tom is president of Silling Associates. A fourteen-year member of the firm, Tom has been a driving force in securing and implementing new work. He oversees projects from inception to completion, working closely with clients and contractors to insure the success of projects under his direction. He takes a "hands-on" approach to each and every project, working closely with clients to define and detail requirements for their facilities.

He has considerable experience in the design of justice facilities, including courthouses, judicial centers, and correctional institutions. With over 1 million square feet of justice-related designs under his belt, Tom has led the firm's efforts in making Silling a regional leader in the field of justice architecture.

Tom graduated with honors in 1990 from the University of Tennessee College of Architecture and Planning. He is a member of the American Institute of Architects and is past president of the West Virginia Chapter of the American Institute of Architects.

Education

Bachelor of Architecture with High Honors
The University of Tennessee 1990

Licenses & Certifications

Licensed to practice architecture West Virginia (1994) , Virginia (2001)

Professional Affiliations

West Virginia AIA, Ex-President & Executive Committee Member
Academy for Justice Architecture, American Institute of Architects

Awards & Recognition

2004 AIA WV Honor Award for Excellence in Architecture, Star USA Federal Credit Union

Notable Project Experience

*Morgan County Courthouse
Berkeley Springs, WV*

*Hampshire County Judicial Center
Romney, WV*

*Putnam County Judicial Building &
Courthouse Addition
Winfield, WV*

*Raleigh County Judicial Center
Beckley, WV*

*Jefferson County Judicial Center
Charles Town, WV*

*Greenbrier County Courthouse
Administrative Services Center
Lewisburg, WV*

*Medina County Courthouse
Medina, OH*

*Allegany County District Court
Cumberland, MD*

*Mineral County 911 Center
Keyser, WV*

*Huttonsville Correctional Center
Huttonsville, WV*

*Mount Olive Correctional Center
Mount Olive, WV*

*Stevens Correctional Facility
Welch, WV*

*St. Marys Correctional Center
St. Marys, WV*

*Martinsburg Correctional Center
Martinsburg, WV*

*WV Lottery Headquarters
Charleston, WV*

*Fleming Hall Athletic, Convocation,
& Academic Center
West Virginia State University*

*Multi-Campus Master Plan
New River Community and
Technical College*

*Star USA Federal Credit Union
St. Albans, WV*





Jody S. Driggs, AIA

Principal

Professional Bio

Jody is a principal with Silling Associates with fourteen years' experience in the design practice. He has led the development of design concepts for a diverse mix of project types, size, and complexity. As a project architect, he is responsible for working closely with the owner to establish clear programmatic needs and design criteria, as well as to develop responsive schematic site plans, floor plans and elevations that blend the meaning and spirit of the owner's program with site and cultural forces.

His conceptual design talents, artistic ability, and versatility have been illustrated in such projects as the award-winning James C. Wilson Student Union, Bible Center Church, Chesapeake Energy's Eastern Regional Headquarters, Tri-State Casino Resort Hotel, and the West Virginia Lottery Headquarters.

Prior to joining Silling, Jody worked in the Urban Design Consultancy Studio in Chattanooga, Tennessee, under AIA Thomas Jefferson Award Winner J. Stroud Watson. Jody is a 1996 graduate of the University of Tennessee College of Architecture and Planning, a member of the American Institute of Architects, a member of the WVAIA Scholarship Committee, and 2010-2011 president for the WVAIA (2010-2011).

Education

Bachelor of Architecture
The University of Tennessee 1996

Licenses & Certifications

Licensed to practice architecture in WV, KY, OH, MD, PA

Professional Affiliations

Past Vice-President, WV Chapter, American Institute of Architects, 2008-2009
President, WV Chapter, American Institute of Architects, 2010-2011

Awards & Recognition

-2005 AIA WV Merit Award for Achievement in Architecture, James C. Wilson Student Union
-2006 The State Journal "40 Under 40" Award Winner
-2007 West Virginia Executive "Young Gun" Award-Winner
-2009 AIA WV Honor Award for Excellence in Architecture, Chesapeake Energy Eastern Regional Headquarters
-2010 AIA WV Merit Award for Achievement in Architecture, Bible Center Church

Notable Project Experience

James C. Wilson
West Virginia State University

Bible Center Church
Charleston, WV

Chesapeake Energy Eastern
Regional Headquarters
Charleston, WV

WV Lottery Headquarters
Charleston, WV

Tri-State Casino Resort Hotel
Cross Lanes, WV

Tri-State Casino Resort Convention
& Conference Center
Cross Lanes, WV

St. Timothy Lutheran Church
Charleston, WV

WVU Tech Student Union
WVU Institute of Technology

Industrial Home for Youth
Salem, WV

St. Marys Correctional Center
St. Marys, WV

Kanawha Valley Heart Specialists
Medical Office Center
South Charleston, WV

Huntington Pediatric Dentistry
Huntington, WV

Downtown Media Center
West Virginia State University

Fleming Hall Athletic, Convocation,
& Academic Center
West Virginia State University

Campus Master Plan
West Virginia State University

Multi-Campus Master Plan
New River Community and
Technical College

Haddad Riverfront Park Stage,
Amphitheatre, & Canopy
Charleston, WV

Orthoclinic, Dr. David Soulsby
South Charleston, WV



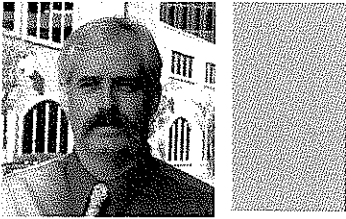

Sean Simon, AIA

Architect & Construction Period Service Manager

Professional Bio

Sean has sixteen years' experience involving all phases of architectural programming, design, construction document production, and construction contract administration. From 1998 through 2007, he operated his own architectural practice providing comprehensive design and project management services for a variety of project types including banking, commercial, government, education, health care, religious, and residential.

Sean joined Silling in 2008 as a Construction Period Service Manager, working closely with the firm's production staff throughout the construction document phase and providing construction contract administration services. He is responsible for facilitating pre-construction meetings providing clear definition of project goals and owner expectations, reviewing contractor submittals, product samples, and shop drawings for conformance to the contract drawings and specifications, attending progress meetings to maintain clear communication with builders, observing installation of materials and systems to verify their conformance with the design intent, and monitoring the project schedule.

Sean earned a Bachelor of Architecture from the University of Tennessee in 1992 and is a member of the West Virginia Chapter of the American Institute of Architects.

Education

Bachelor of Architecture
The University of Tennessee, 1992

Licenses & Certifications

Licensed to practice architecture in West Virginia, Maryland, Ohio, Virginia, and Pennsylvania.

Professional Affiliations

American Institute of Architects, West Virginia Chapter (AIAWV)

Civic Involvement

Cub Scoutmaster for Pack 434—Serves as Unit Commissioner for Little Kanawha District, Allhok Council; Little Kanawha District Roundtable

Notable Project Experience

*Morgan County Courthouse
Berkeley Springs, WV*

*Raleigh County Judicial Center
Beckley, WV*

*Hampshire County WPA Annex
Romney, WV*

*Hampshire County Sheriff's Building
Romney, WV*

*Tri-State Casino Resort Hotel
Cross Lanes, WV*

Anthony Correctional Center

*Huttonsville Correctional Work Camp
Huttonsville, WV*

*Martinsburg Correctional Center
Martinsburg, WV*

*Putnam County Courthouse
Winfield, WV*

*Hamblin Hall Boiler Replacement
West Virginia State University*

*Ferrell Hall Chiller Replacement
West Virginia State University*

*Sullivan Hall Elevator Replacement
West Virginia State University*

*Wyoming County Courthouse Annex
Pineville, WV*





Martin Klapproth, Associate AIA

Architectural Project Manager

Professional Bio

Martin is a graduate architect with 22 years' experience in the architectural industry, including all phases of project design. From 1986 through 1996, he served as an Architectural Designer providing schematic design, construction document, and I.T. support. Martin joined The HDMR Group in 1996 where spent the next ten years providing schematic and construction document production support, project management and supervision, as well as marketing, website, and I.T. support. During this period, he provided various design, production, and/or project management services for the Marshall University Robert C. Byrd Biotechnology/Science Center, Marshall University-South Charleston Campus, West Liberty State College Academic, Sports, & Recreation Facility, and the Petroleum Development Corporation Headquarters, among others.

Mr. Klapproth joined Silling Associates in 2008 as a Project Manager. His primary responsibilities include schematic design, contract document production and coordination, construction contract administration support, and overall project support.

Education

Bachelor of Architecture

The University of Cincinnati, 2003

Previous Experience

ZMM, Inc.—Charleston, WV (1986-1996)

Architectural Designer

The HDMR Group, Inc.—Charleston, WV (1996-2006)

Architectural Designer

Professional Affiliations

American Institute of Architects - WV Chapter (AIAWV)

Notable Project Experience

Jefferson County Courthouse
Charles Town, WV

Raleigh County Judicial Center
Beckley, WV

Morgan County Courthouse
Berkeley Springs, WV

Medina County Courthouse
Medina, OH

Tri-State Casino Resort Hotel
Cross Lanes, WV

Robert C. Byrd Biotechnology Science
Center, Huntington, WV

Marshall University Graduate College
South Charleston, WV

Academic, Sports, & Recreation
Center, West Liberty State College

Petroleum Development Corporation
Headquarters, Bridgeport, WV

Student Housing Study
Marshall University

Bigley Mall LLC, Foodland
Charleston, WV



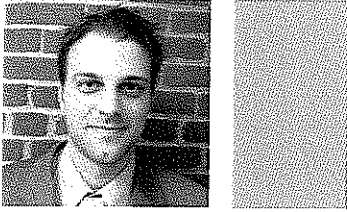

Jeremy Jones, Associate AIA

Architectural Project Manager

Professional Bio

Jeremy is a graduate architect with nine years' experience in the architectural industry, including all phases of project design, development, production, presentation, and coordination of contract documents. He has completed all IDP training requirements and is currently testing for licensure through the National Council of Architectural Registration Boards. Jeremy's educational experience included a study abroad of European Architecture at the Polytechnic Institute of Krakow, Poland, spring semester of 2002. Travel included Austria, Germany, the Netherlands, Italy, England, France, the Czech Republic, and Spain.

He possesses advanced skills using three-dimensional computer modeling programs and rendering techniques.

Education

Bachelor of Architecture, Cum Laude
The University of Tennessee 2003

Professional Affiliations

American Institute of Architects - WV Chapter
Historic Resources Committee

Awards & Recognition

- Fourth Year Design of Excellence Award, top design fourth year level
- 2002 West Virginia AIA Scholarship, state's top architectural student award
- 2001 & 2002 Mark Freeman Scholarships, architecture program's top monetary award
- 2001 U.T. Foreign Travel Scholarship, university's top abroad studies award
- 2000 Tennessee Foundation Scholarship, middle Tennessee AIA award
- Tau Sigma Delta Architecture Honor Society
- Golden Key International Honor Society
- National Collegiate Scholar
- Phi Eta Sigma Honor Society, freshman honorary
- Phi Kappa Phi Honor Society, senior honorary.

Notable Project Experience

*Allegheny County District Court
Cumberland, MD*

*Haddad Riverfront Park
Amphitheatre, Stage, & Canopy
Charleston, WV*

*Chesapeake Energy Eastern Regional
Headquarters, Charleston, WV*

*Chesapeake Energy Building One
Oklahoma City, OK*

*Jefferson County Courthouse
Charles Town, WV*

*Kanawha Valley Heart Specialists
South Charleston, WV*

*Morgan County Courthouse
Berkeley Springs, WV*

*Raleigh County Judicial Center
Beckley, WV*

*WV Lottery Headquarters
Charleston, WV*

*WVDOC Work Release Centers
Multiple Locations, WV*

*St. Johns United Methodist Church
Spencer, WV*

*St. Matthews Episcopal Church
Charleston, WV*

*Dr. Holmes Orthodontist
Charleston, WV*

*Beverly Hills Baptist Church
Huntington, WV*

*Governor's Mansion Restoration
WV State Capital Complex*

*New Health & Technical Center
Southern WV Community College*



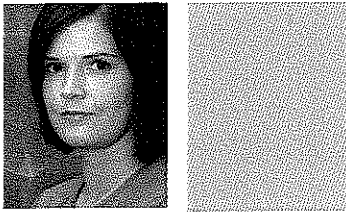

Kim Ellis, Associate AIA

Interior Designer

Professional Bio

Kim Ellis joined Silling Associates in 2008 and brings a diverse experience within both the architectural and interior design industries. Upon completing her Interior Design Internship at the award-winning Dorothy Draper and Company in New York, Kim has enjoyed over twelve years working within the architectural interiors discipline. She has a particular strength in defining client needs for interiors planning, function, feasibility, and image -- both in new construction and renovation projects. In addition, Kim leads the firm's interior design services including space planning, conceptual design, strategic consulting, adaptive reuse, furniture & accessories design, furniture specifications, purchasing coordination, and budget planning.

She has provided extensive interior design, architectural production and coordination, construction administration, and architectural team training services. In addition, Kim's previous professional experience includes code research for various restaurant, retail, petroleum, educational, and business projects in many jurisdictions across the United States, as well as local building, electrical, plumbing, mechanical, fire, and ADA accessibility guidelines.

Education

Bachelor of Interior Design

Minor: Fine Arts, Carney Varney Department of Art and Design
University of Charleston, 1997

Previous Experience

Dorothy Draper and Company—New York NY (1996)
Interior Design Intern

Shremshock Architects—Columbus, OH (1997-1999)
Interior Designer

WD Partners—Columbus, OH (1999-2004)
Architectural Project Leader and Team Trainer

ZMM, Inc.—Charleston, WV (2004-2008)
Interior Designer/Architectural Technician

Professional Affiliations

American Institute of Architects - WV Chapter (AIAWV)

Civic Involvement

Vice-President, Fort Hill Child Development Center Parent Advisory Council * Member-Holtz Elementary School PTO * Parent Volunteer-Holtz Elementary School Yearbook * Volunteer-Chandler Elementary School Reading Tutor Program

Notable Project Experience

*Allegany County District Court
Cumberland, MD*

*Morgan County Courthouse
Berkeley Springs, WV*

*Raleigh County Courthouse
Beckley, WV*

*Moses Residence
Barboursville, WV*

*WV Supreme Court of Appeals
Charleston, WV*

*Tri-State Casino and Hotel
Cross Lanes, WV*

*Hacker Valley Pre-K – 8 School
Webster County, WV*

*New River Elementary
Fayette County, WV*

*Mountaineer Middle School
Harrison County, WV*

*Southside Elementary
Cabell County, WV*

*Huntington Middle School
Cabell County, WV*

*The Boulevard at 2412
Charleston, WV*

*Bob Evans Restaurants
National Locations*

*Perkins Restaurants
National Locations*

*The Home Depot
National Locations*

*BP Oil
National Locations*

*Exxon Mobil
National Locations*

*Abercrombie and Fitch
National Locations*

*The Grand Hotel
Mackinac Island, MI*





Jason Rutledge, Associate AIA

Senior CAD Technician

Professional Bio

Jason provides over eight years' experience with Silling Associates and provides production coordination primarily during the design development and construction document phases. In addition to his primary CAD production responsibilities, he provides construction administration support, office IT support, production team training and support, archived drawing management, and project coordination.

He possesses advanced skills using three-dimensional computer modeling programs and rendering techniques.

Education

Certificate in Computer-Aided Drafting & Design
West Virginia State University, 2002
Ben Franklin Career & Technical College, 1999

Technical Skills

Microstation, AutoCAD, Photoshop, 3-Dimensional Modeling

Professional Affiliations

Associate Member, WV Chapter of the American Institute of Architects

Awards & Recognition

First Place - WV VICA Architectural Drafting & Design Competition, 2002

Notable Project Experience

James C. Wilson
West Virginia State University

Bible Center Church
Charleston, WV

Chesapeake Energy Eastern
Regional Headquarters
Charleston, WV

Morgan County Courthouse
Berkeley Springs, WV

Raleigh County Judicial Center
Beckley, WV

Hampshire County Judicial Center
Romney, WV

Tri-State Casino Resort Hotel
Cross Lanes, WV

St. Timothy Lutheran Church
Charleston, WV

Spilman, Thomas, & Battle Law Office
Charleston, WV

WVU Tech Student Union
WVU Institute of Technology

Stevens Correctional Facility
Welch, WV

Huffonsville Correctional Center
Huffonsville, WV

Martinsburg Correctional Center
Martinsburg, WV

St. Marys Correctional Center
St. Marys, WV

Mt. Olive Correctional Complex
Mt. Olive, WV

Orthoclinic, Dr. David Soulsby
South Charleston, WV

Star USA Federal Credit Union
St. Albans, WV

McDowell County National Banks
Beaver & Daniels, WV

First National Bank
White Sulphur Springs, WV





Diversity of Experience.

ARCHITECTURE FOR JUSTICE

Courthouses
Judicial Centers
Governmental Administration
Correctional Institutions
Public Safety Centers

ARCHITECTURE FOR LEARNING

Colleges & Universities
Community & Technical Colleges
Secondary Education

ARCHITECTURE FOR HEALTH

Hospitals & Medical
Medical Office Buildings

ARCHITECTURE FOR LIVING

Custom Residences
Loft Housing & Urban Living
Condominiums

ARCHITECTURE FOR WORKING

Corporate & Office
Governmental
Banking & Financial
Retail & Hospitality

ARCHITECTURE FOR WORSHIP

Worship Centers
Educational Centers

ARCHITECTURE FOR RECREATION

Hotels & Resorts
Riverfront Development
Athletic Recreation



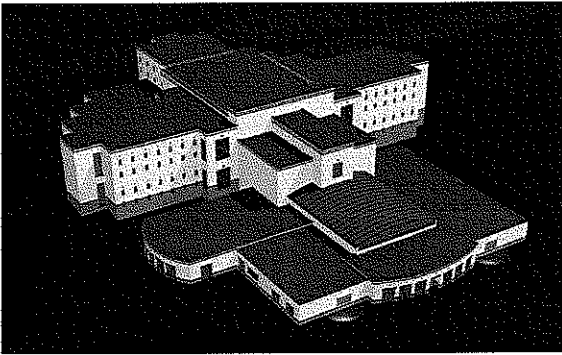
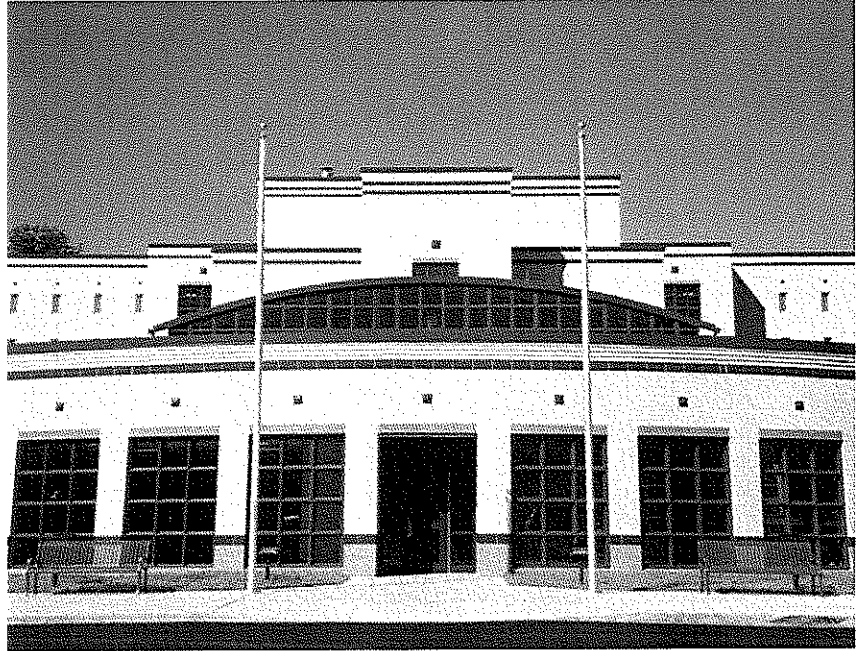
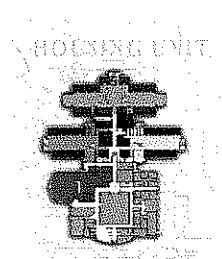
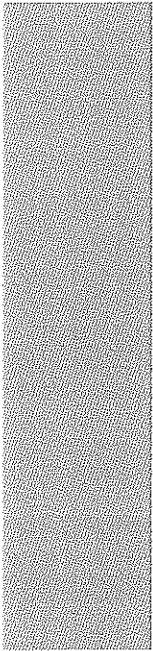

Industrial Home for Youth Salem, West Virginia

The existing Industrial Home for Youth was a secure compound which originally included a resident capacity of 115 post-adjudicated youths with an inventory of seven structures located along the contours of two distinct ridges. The project scope included a 200-bed, 100,000 gsf new housing building, a 17,000 gsf educational building, demolition of Sutton and Silver Hall, and a 138-space parking area to a very limited campus site.

SIZE: 117,000 GSF

TYPE: NEW CONSTRUCTION

STATUS: COMPLETED IN 2000

CONTACT: STEVE CANTERBURY, ADMINISTRATIVE DIRECTOR, WV SUPREME COURT, 304.558.0145

Operationally, the Housing building called for a design that greatly minimized supervision while maximizing security. The housing units are designed to operate under a direct supervision model with unit managers, counselors and corrections staff physically located on the unit. A corrections officer is located at an electronic locking panel located in the dayroom with clear visibility of all resident rooms. Thus, one housing building with limited circulation and primary security checkpoint was favored over independent housing units. Programmatically, the housing building contains six housing units, main campus kitchen and dining, gymnasium and recreation spaces, housing, medical, administration, intake, campus central control, operations center, and staff services.

The Educational Building is located on the opposite hilltop to the west of the housing building. The building floor plan is a simple double loaded corridor with a "T" entry. General classrooms align a single side along the front of the building, while vocational/ trades classrooms align the back.



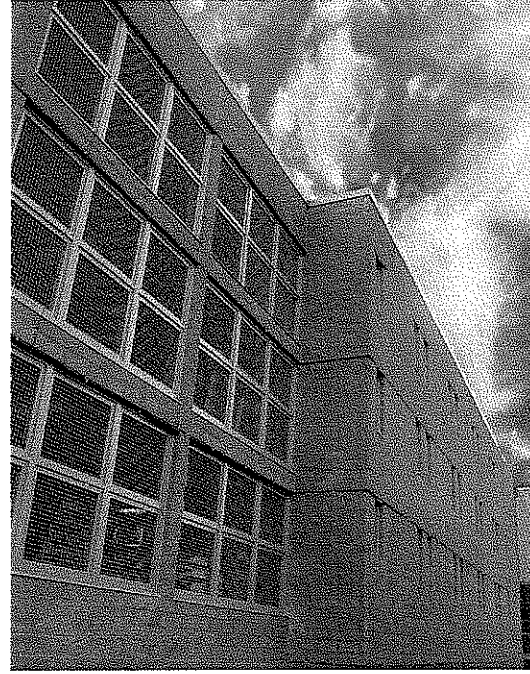
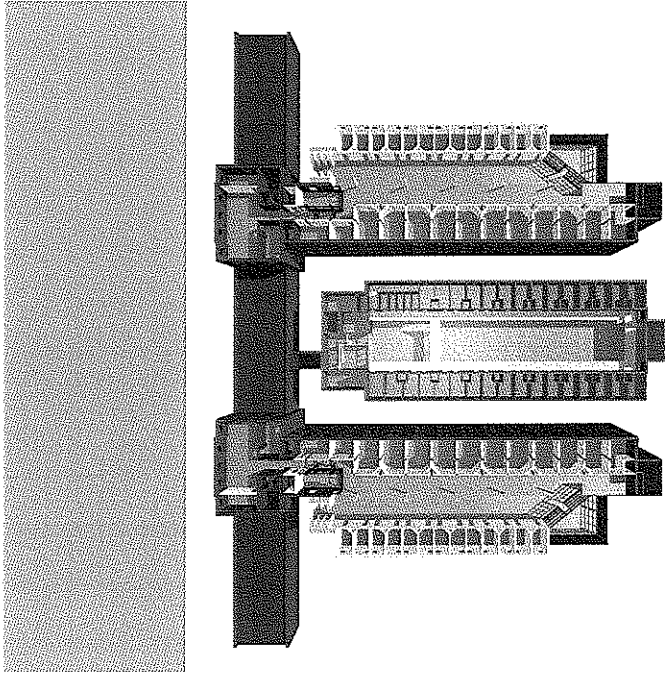

SIZE: 74,500 GSF

TYPE: ADDITIONS & RENOVATIONS

STATUS: 2007

CONTACT: JIM RUBENSTEIN, COMMISSIONER, WV
DIVISION OF CORRECTIONS, 304.558.2036

Huttonsville Correctional Center

Huttonsville, West Virginia

Completed in early 2007, the Dormitory Addition and Renovation project involved a creative lateral expansion of the two three-story dormitory wings and converting them from open, dormitory style housing into more secure two- and six-man housing cells. The primary objective of this phase was to add 200 beds while increasing both staff efficiency and safety.

The conversion increases each floor from 45 to 80 inmates, while maintaining current staffing patterns and introducing effective direct supervision. Six-man cells are developed inside the footprint of the 1938 section with steel cell walls that can be accommodated by the existing structural system. Two-man CMU cells are developed within the new footprint. All cells are wet with electronically controlled stainless steel combination toilet/lav units that minimize utility maintenance costs. Secure direct access recreation areas support effective management, allowing inmate outdoor access without mixing population with other housing units.

As second phase of the project included the replacement of two existing 1975 fuel oil 600hp Cleaver Brooks boilers and related support, including electrical service, de-aerator tanks, and water softeners. A third phase of the project involved the replacement of the institution's kitchen concrete floor slab, which had suffered extreme deterioration, including cracked beams, erosion and spalling of the concrete from the joists, and exposed and rusted steel reinforcing. Our design solution included the temporary closure of the kitchen during structural repairs, the removal and temporary storage of existing kitchen equipment, the demolition and replacement of nine structural bays with a new elevated slab, new kitchen flooring, and new electrical conduit and mechanical piping.



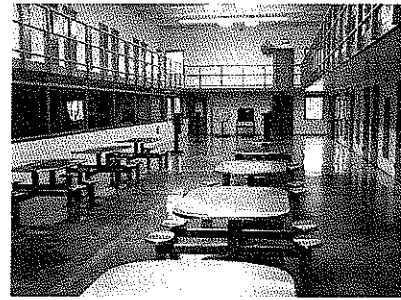
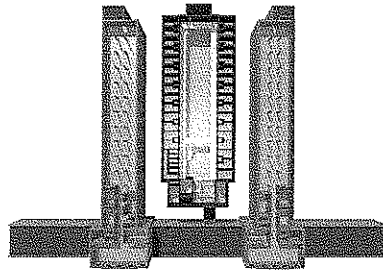
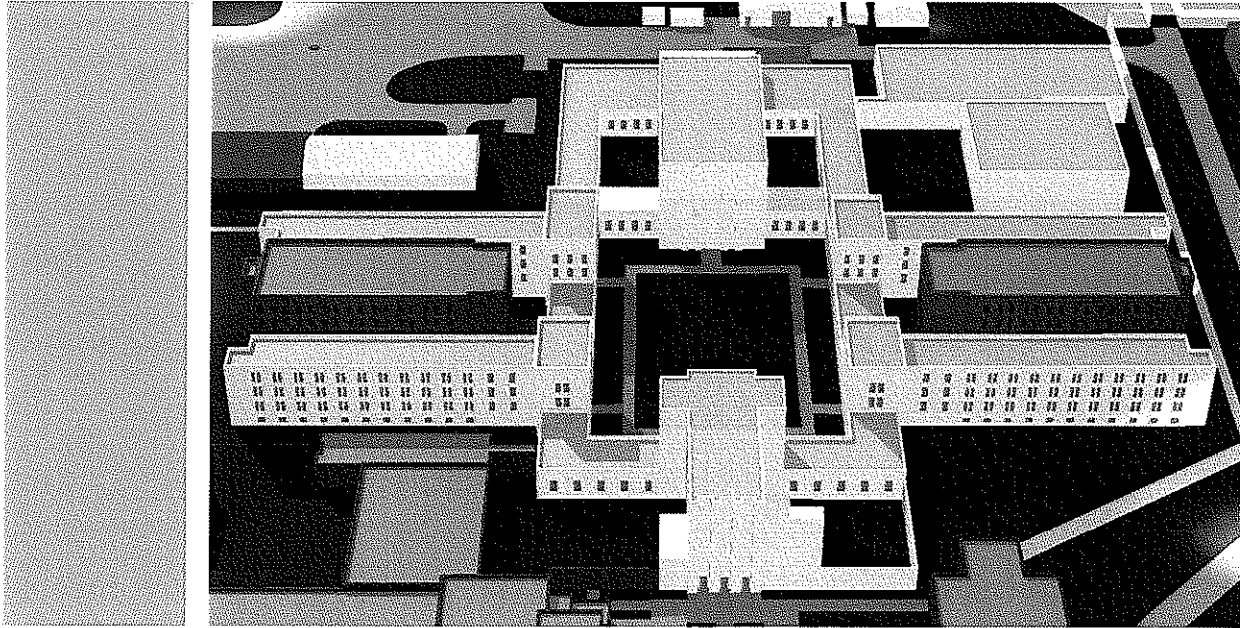

SIZE: 101,875 GSF COMBINED

TYPE: NEW CONSTRUCTION & RENOVATIONS

STATUS: 2000

CONTACT: JIM RUBENSTEIN, COMMISSIONER, WV
DIVISION OF CORRECTIONS, 304.558.2036

Huttonsville Correctional Center

Huttonsville, West Virginia

Originally designed by Tucker and Silling Architects (a forerunner to Silling Associates) in 1938, the Huttonsville Correctional Center has undergone numerous renovations and additions to maintain its usefulness as a primary adult male correctional facility. The Huttonsville Correctional Center Cell Block Addition project involved additions and renovations totaling a combined 101,875 square feet and included two, 120-bed medium security cell blocks placed between the existing dormitory components and linked to the primary corridor system.

Additional project components included prison industries, vocational education, administration renovation and addition, security tower, chapel, laundry renovation and addition, kitchen renovation, security fence and high mast lighting, clinical facilities renovation, and mechanical upgrades.



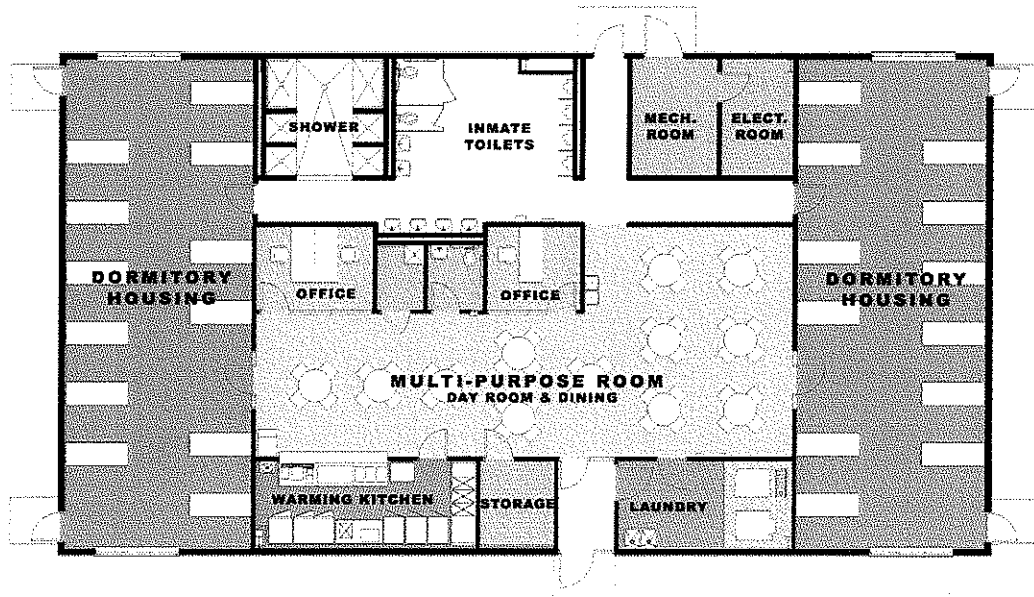
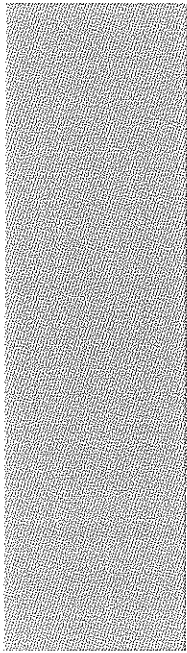

SIZE: 5,400 GSF

TYPE: NEW CONSTRUCTION

STATUS: CONSTRUCTION PHASE

CONTACT: PHILLIP FARLEY, CONSTRUCTION MANAGER,
WV DIVISION OF CORRECTIONS, 304.558.8045

Huttonsville Correctional Center Work Camp

Huttonsville, West Virginia

This latest addition to the Huttonsville Correctional Center campus provides a new, 5,400 square foot work camp housing 48 inmates for the WV Division of Corrections. The facility also includes an open multi-purpose room which will serve as a day room and dining area, two C.O. offices, a full warming kitchen, showers and toilets, and laundry room. Construction is set to begin in the Spring of 2010.

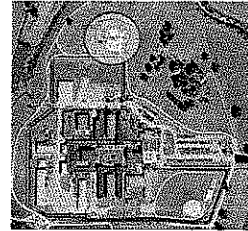

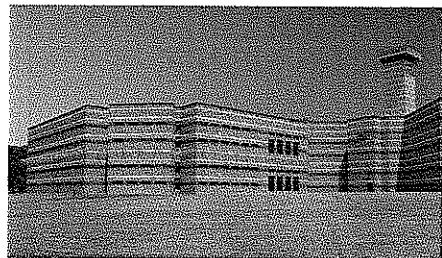
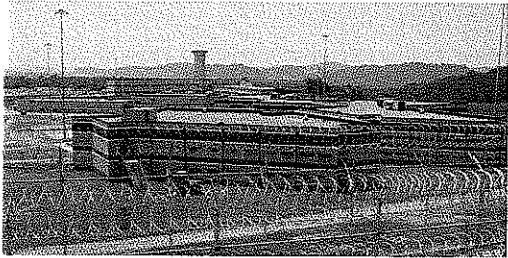
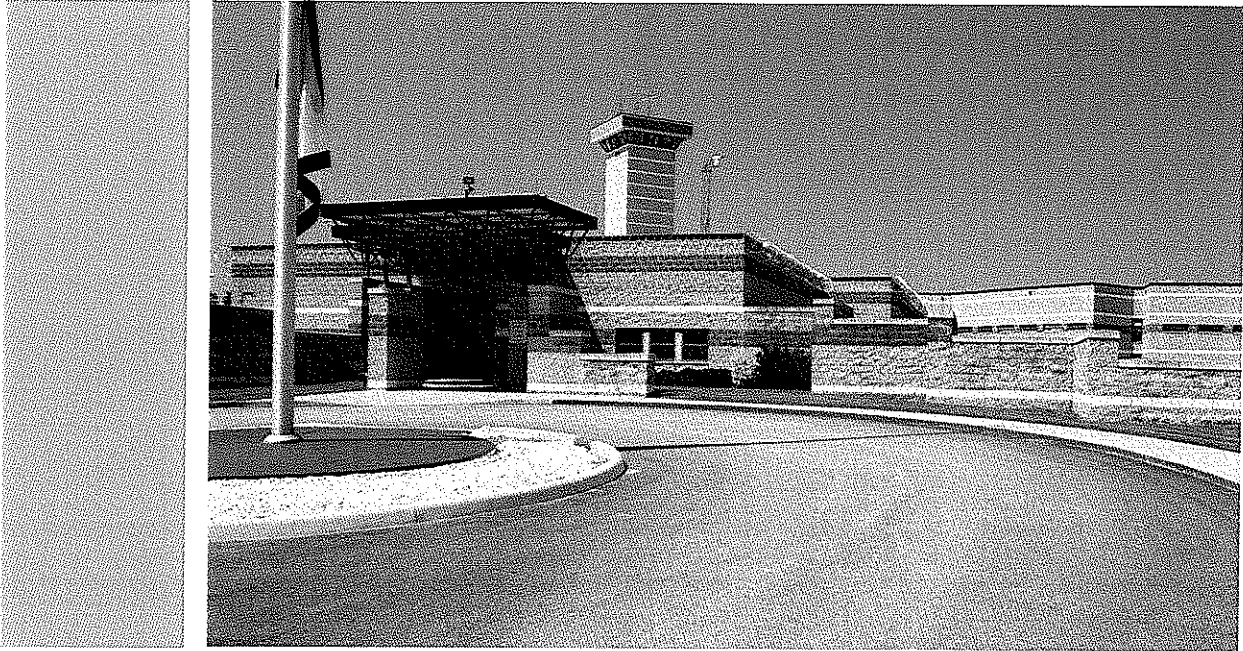

SIZE: 425,000 GSF

TYPE: NEW CONSTRUCTION

STATUS: 1995

CONTACT: JIM RUBENSTIEN, COMMISSIONER, WEST VIRGINIA DIVISION OF CORRECTIONS, 304.558.2036

Mt. Olive Correctional Complex

Mount Olive, West Virginia

Mount Olive is West Virginia's primary correctional facility with a capacity of 800 adult male inmates. It is a 425,000 sf campus of fifteen buildings arranged in a classic fan shape arrangement inside a secure compound. The building inventory included medium, maximum and minimum security housing with typical support facilities such as education, recreation, prison industries, kitchen and dining, visitation, intake and classification, medical, and administration.

The 80-acre former strip mine site which had uncontrolled mine overburden fill had been deep mined below, requiring extensive study and engineering to design several different foundation structural systems. The infrastructure and support services were designed for future growth and can accommodate 240 additional beds when needed.



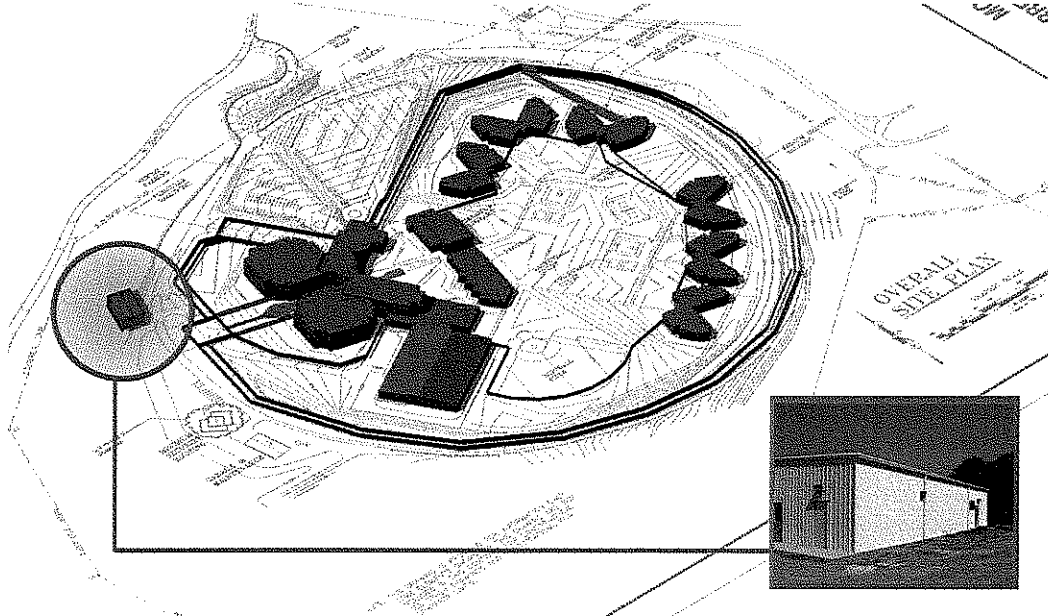
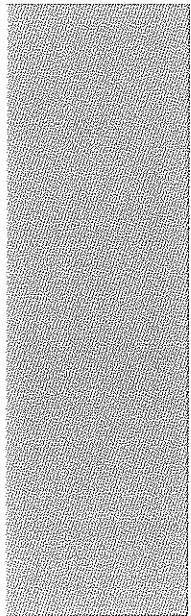

SIZE: 3,800 GSF

TYPE: NEW CONSTRUCTION

STATUS: COMPLETED IN 2009

CONTACT: JIM RUBENSTIEN, COMMISSIONER, WEST VIRGINIA DIVISION OF CORRECTIONS, 304.558.2036

Mt. Olive Command Center

Mt. Olive, West Virginia

Completed in 2009, the new Command Center project involved the design and construction of a 3,800 gsf pre-engineered metal building housing the Complex's Emergency Command Center, a training room for correctional officers, an armory, offices, and kitchenette.



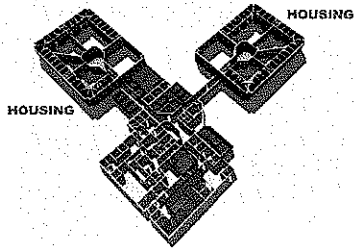

SIZE: 47,400 GSF

TYPE: ADDITIONS & RENOVATIONS

STATUS: COMPLETED IN 2005 & 2008

CONTACT: JIM RUBENSTIEN, COMMISSIONER, WEST VIRGINIA DIVISION OF CORRECTIONS, 304.558.2036

Martinsburg Correctional Center Martinsburg, West Virginia

This \$2.9 million project involved the conversion of the original 45,000 sf regional jail into an intake facility for the WV Division of Corrections. The facility houses 120 inmates for Classification. The renovations included upgrades to the mechanical and electrical systems, physical security, and addition of intake administrative space. Construction was completed in 2005.

In 2008, Silling provided comprehensive design services for a 2,400 square foot addition to the Center, featuring a large conference/meeting room, administrative offices, and hallway. The project also involved an expansion of the parking area.





SIZE: 7,560 GSF

TYPE: RENOVATIONS & PRESERVATION

STATUS: 2002

CONTACT: JIM RUBENSTEIN, COMMISSIONER, WV
DIVISION OF CORRECTIONS, 304.558.2036

Pruntytown Wardens Residence

Pruntytown, West Virginia

Designed for the WV Division of Corrections, the Pruntytown Warden's Residence project provided state-of-the-art office space within this 7,560 square foot, 1920s arts and crafts style former residence. Key components of the design included exterior upgrades and restoration, interior refinishing and improvements, ADA improvements, and complete mechanical, electrical, plumbing, and data & telecommunications upgrades. This project is a prime example of our design team's ability to provide all of the necessary amenities of 21st century office space while remaining sympathetic to the language of a historical residential structure.



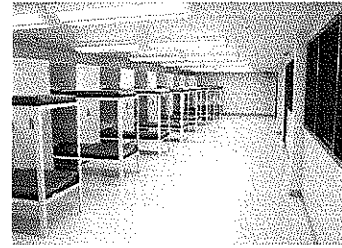
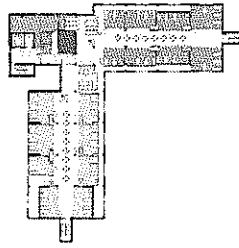
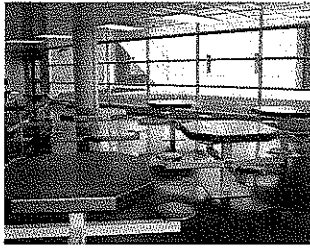
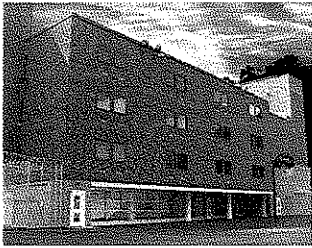

SIZE: 76,160 GSF

TYPE: ADAPTIVE REUSE

STATUS: COMPLETED IN 2006

CONTACT: JACK CAFFREY, MCDOWELL COUNTY
ECONOMIC DEVELOPMENT AUTHORITY, 304.436.5291

Stevens Correctional Facility

Welch, West Virginia

The Stevens project was an endeavor of the McDowell County Economic Development Authority to convert a former hospital into a state correctional facility. Renovations and additions resulted in housing for 334 inmates and support facilities including classrooms, administration, medical, kitchen and

laundry. Each wing of the four-story 1976 building becomes a housing unit consisting of 46 inmates in double-bunk cells constructed of CMU. Each housing unit shares a secure indirect supervision unit that promotes efficient staffing and inmate control. Dining, education and administration are located on the ground floor in captured open vehicular circulation space beneath the wings of the 1976 building. Vertical inmate movement and perimeter building/site security is monitored by a master control unit strategically located on the ground floor in the heart of inmate circulation. Master control has direct visual observation of visitation, outdoor recreation, dining and education entrance. The facility features state of the art electronic security video surveillance and perimeter management system. The project featured a total reconstruction of all interior architectural, mechanical, electrical, fire protection, and communications systems into the shell of the abandoned hospital.



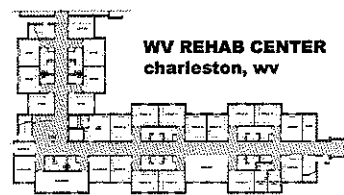
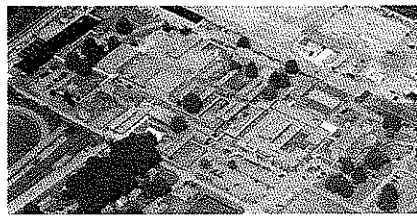
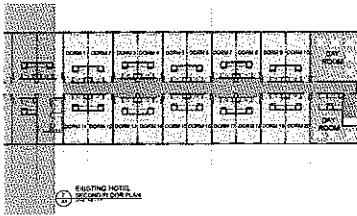

SIZE: VARIOUS

TYPE: ADDITIONS & RENOVATIONS

STATUS: PROGRAMMING/DESIGN

CONTACT: PHILLIP FARLEY, CONSTRUCTION MANAGER,
WV DIVISION OF CORRECTIONS, 304.558.2036

WVDOC Work Release Centers

Various Locations, West Virginia

In an effort to help alleviate jail and prison overcrowding and to save taxpayer money and better utilize existing state facilities, the WVDOC commissioned Silling to help create four strategically-located work release/training centers within the state. The project includes the renovation and adaptive reuse of a former hotel in Parkersburg, the renovation of a portion of the existing WV Rehabilitation Center in Charleston, the renovation of the 4th floor of the Jackie Withrow Hospital in Beckley, and a new facility in Fairmont. These facilities will combine to house over 350 inmates for the WVDOC, with each facility housing approximately 60-120 inmates.



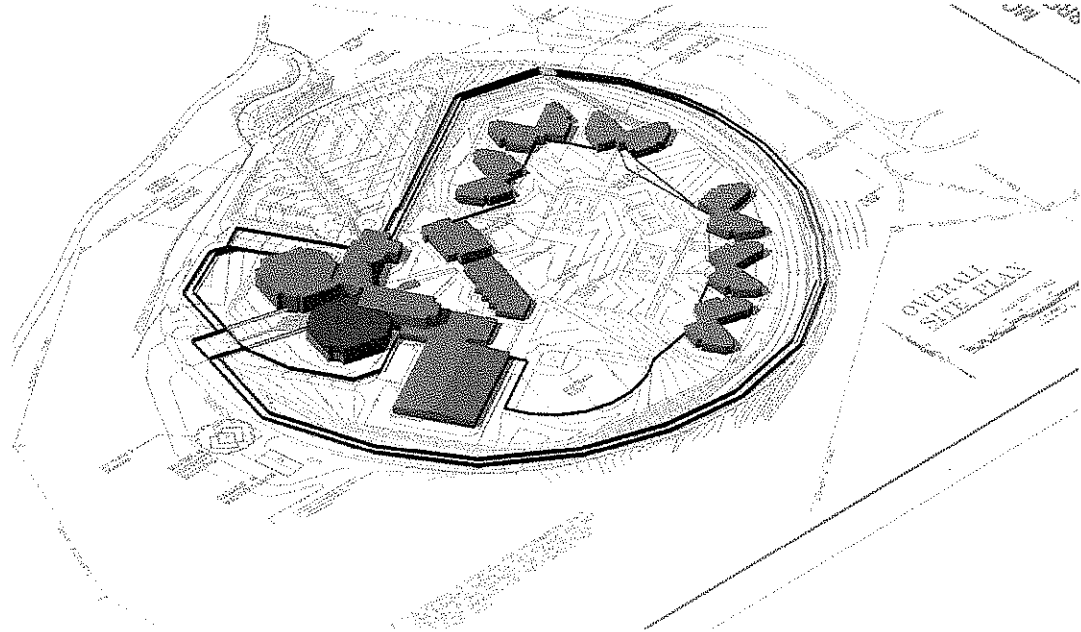
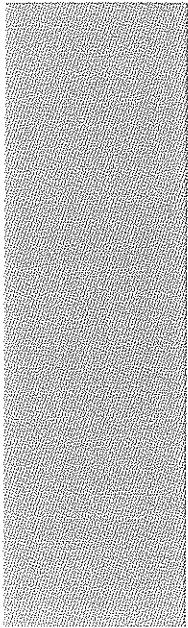

SIZE: 41,000 GSF

TYPE: MEDICAL SERVICES & HOUSING ADDITION

STATUS: SCHEMATIC DESIGN COMPLETE

CONTACT: JIM RUBENSTIEN, COMMISSIONER, WEST VIRGINIA DIVISION OF CORRECTIONS, 304.558.2036

Mt. Olive Special Needs Unit

Mt. Olive, West Virginia

Current trends in corrections in the US has seen an increased demand for special inmate housing that includes mental health, drug treatment, sexual offenders, and depression/suicide observation. An aging and characteristically increasingly ill population is also placing greater demand on health care services in correctional facilities. This fundamental change in inmate population dramatically impacts the cost of operations and greatly increases staff to inmate ratios.

A new special needs facility is needed to address this change at the MOCC. The original 1994 planning projected a mirror image of a maximum security housing pod at a strategic facility location connecting to primary circulation at master control. As needs changed this area will be utilized for the special housing unit. The special needs unit is a 41,000 SF single story building and includes a comprehensive medical clinic, trauma center, pharmacy, and medical offices. Primary goals and concepts include: Facilitating inmate movement through treatment and returning inmates to the general population within a minimum period resulting in less operating costs, and an efficient arrangement of program to minimize staff and operational costs. The floor plan is thus arranged to combine a complex mix of populations with an efficient amount of correctional, program and medical staff. Natural light is introduced into dayroom and medical areas with a series of clerestory windows at raised building sections.

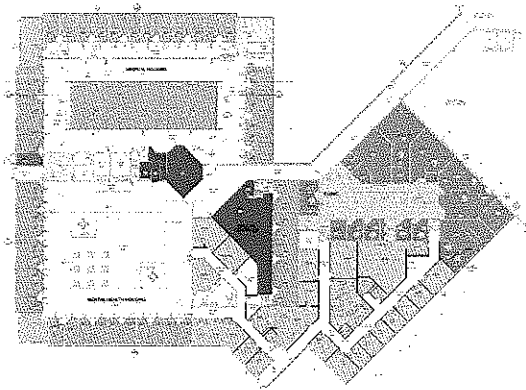



SIZE: 1,700 GSF & 1,500 GSF

TYPE: NEW CONSTRUCTION

STATUS: COMPLETED IN 2001

CONTACT: BRYCE CASTO, VP OF STUDENT SERVICES,
WEST VIRGINIA STATE UNIVERSITY , 304.766.3000

Women's Transitional Housing West Virginia State University

The H.O.U.S.E. Project provides transitional living for two different groups of undergraduate students. Phase I provides a safe and stable environment for at-risk and former foster youth wanting to complete a college education. The students receive life-skills assistance and other support services to make the transition to college life. The 1,700 gsf facility includes four student bedrooms, living/dining room, full kitchen, laundry room, resident assistant suite, and case manager office.

Phase II housing provides living space to former residents of women's shelters and their children. The project provides education on becoming self-sufficient, while the residents obtain a college education. The 1,500 gsf facility includes three separate suites—one 2-bedroom suite with living/dining/kitchen—and two 1-bedroom suites with living/dining/kitchen.





See What Our Clients Have To Say About Us.

Mr. Jim Rubenstein, Commissioner
WV Division of Corrections
112 California Avenue, Room 300
Charleston, WV 25305
304.558.2036

Mr. Steve Canterbury, Administrative Director
WV Supreme Court
State Capitol Complex
Building 1, Room E-100
Charleston, WV 25305-0830
304.558.0145

Mr. Phillip Farley, Construction Manager
WV Division of Corrections
112 California Avenue, Room 300
Charleston, WV 25305
304.558.2036

Mr. Bill Wimer
Former Construction Manager
WV Division of Corrections
112 California Avenue, Room 300
Charleston, WV 25305
304.419.0213 (cell)

Mr. Walt Davis, Chairman
Hampshire County Building Commission
405 West Main Street
Romney, WV 26757
540.539.1909 (cell)



ABOUT THE FIRM

Scheeser Buckley Mayfield LLC is an Ohio-based Consulting Engineering firm that serves clients throughout Ohio and the surrounding states. The firm was established in 1959 by Walter L. Scheeser and Edwin J. Buckley, specializing in the design of mechanical systems for the construction industry. The firm has enjoyed a steady growth in clients and geographical area served throughout its history, and its services now include electrical, civil, and telecommunication design.

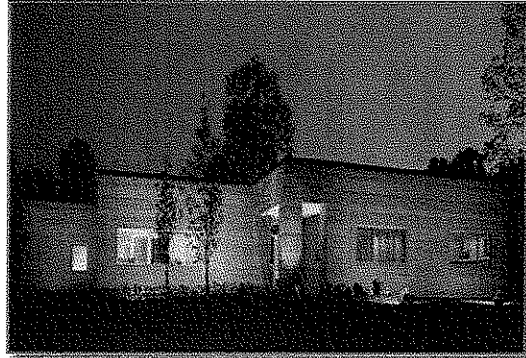

Scheeser Buckley Mayfield LLC has developed an outstanding reputation for both its accessibility to its clients and the clarity and completeness of its documents. The firm has been a leader in the application of new technology. It has extensive experience in the design and analysis of projects of all sizes, which it can draw upon for future projects. Each project requires an analysis of the most cost effective system available based on the client's design parameters. It is also the responsibility of the design team to determine if other options exist which may be beyond the scope of the current budget and which need to be considered on the current project to allow for future growth. Scheeser Buckley Mayfield LLC gives this personal attention to each project by determining the project design which can be implemented within the client's budget while applying innovative design concepts.

Many of Scheeser Buckley Mayfield's projects originate from clients who have used its services previously and wish to continue a professional association. Scheeser Buckley Mayfield LLC strives to provide very professional and competent engineering services to all of our clients and to develop a personal relationship with these clients. This on-going association with clients provides an opportunity for them to better understand design concepts as well as the logic behind the decisions which may affect their systems for many years after the project's completion.

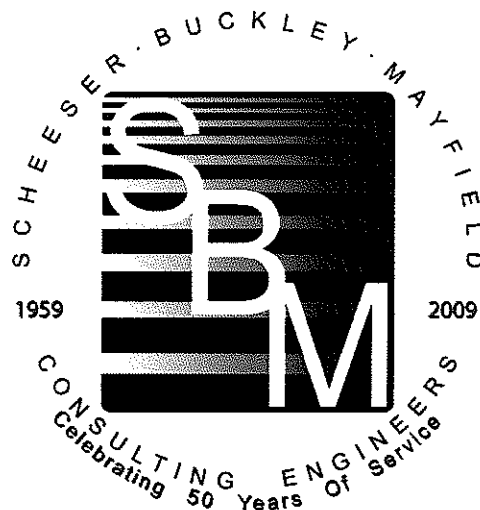

MICHAEL P. WESNER, P.E., LEED AP, CBCP VICE PRESIDENT - MECHANICAL ENGINEERING

PERSONAL RESUME

Mike is a graduate of Ohio State University in Columbus, Ohio. He received a Bachelor of Science Degree in Mechanical Engineering in 1981 and later that year joined the consulting firm of Scheeser Buckley Mayfield LLC which was then known as Scheeser*Buckley*Keyser.

During his first few years with the firm, Mike was heavily involved with the Title III of the National Energy Conservation Policy Act (NECPA). This governmental program was established as a cost sharing energy conservation grant programs. This program provided funds to study the operation of schools and hospitals to determine if there were ways to reduce their energy consumption. The program then funded energy conservation measures identified in the reports. As a result of this involvement in many audits and retrofit programs for public school buildings, college and university buildings and hospitals, Mike gained valuable experience in formulating and implementing energy conservation programs in buildings that result in real world savings. This experience carries on in the work that Mike does today.

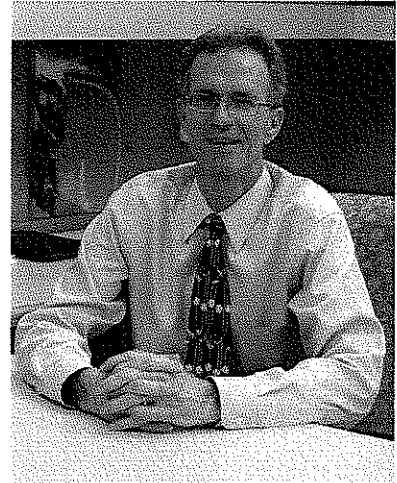

Since the mid 1980's Mike's project experience has been concentrated in the following areas:

- Large hospital Expansion and remodeling projects.
- Hospital Boiler Plant / Chiller Plant replacement projects.
- University Laboratory projects, both new construction and renovation.
- University Classroom Facilities
- University Dormitory Facilities
- Animal research facilities.
- Secondary education facilities.
- Industrial facilities.
- Telephone / Communications buildings
- Recreation/Athletic Fitness Centers
- Worship Centers

On all of the above facility types, Mike has acted as the Principal in Charge for the firm. The Principal in Charge (PIC) is the single point of contact and is responsible to make sure the project gets done on time and on budget.

Other types of project experience Mike has had are listed as follows:

- Projects where SBM was the prime design professional hired by the Owner. Typically this has been for chiller plant/boiler plant or other type of main A/C system replacement. This work involved hiring the sub-consultants, preparing the budget/schedule, writing the "front end" specification documents and doing all of the day to day construction administration.
- Projects where SBM was hired to diagnose and correct mechanical system problems
- Projects where SBM was hired to do Mechanical and Electrical Construction Cost Estimating

Mike is a LEED™ 2.0 Accredited Professional and a member of ASHRAE, ASPE, NFPA and BOCA. In 2009, Mike received his Certified Building Commissioning Professional (CBCP) administered by the AEE (Association of Energy Engineers).

JAMES E. ECKMAN, P.E., LC, LEED AP, CBCP PRESIDENT - ELECTRICAL ENGINEER

PERSONAL RESUME

Mr. Eckman attended The University of Akron where he received his Bachelor of Science Degree in Electrical Engineering in 1984.

After graduation, Mr. Eckman began his career as a consulting engineer by accepting a position as junior engineer with Kucheman, Peters and Tschantz, Inc., an electrical consulting firm in Akron, Ohio. During this engagement, he gained experience in the electrical design of commercial, industrial and healthcare facilities. Mr. Eckman also served as project manager for many of the projects he designed.

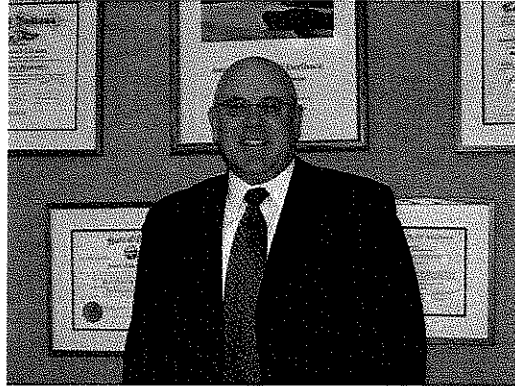

Concurrently, Mr. Eckman taught an electrical engineering course called "Illumination" at The University of Akron.

After leaving KPT, Inc. in 1987, Mr. Eckman gained additional experience in the construction industry by accepting the position of Engineer/Estimator for Thompson Electric, Inc. in Munroe Falls, Ohio. During this engagement, he designed and acted as project manager for several large industrial projects. He also earned electrical contractor licenses in several area communities.

Desiring to further his career as a consulting engineer, Mr. Eckman accepted a position of Senior Engineer with Scheeser Buckley Mayfield LLC in 1989. Mr. Eckman was promoted to the position of Associate in 1990, became a Principal in the firm in 1991 and Vice President of Electrical Engineering in 1992, and President in 2003.

Mr. Eckman was a member of the Institute of Electrical and Electronics Engineers for eight years and is currently an active member of the Electrical League of Northeastern Ohio and the Illuminating Engineering Society (IES). Mr. Eckman has served as Treasurer and President of the Cleveland/Akron IES section and a member of the Executive Committee for the Electrical League. Mr. Eckman served on the College of Engineering Advancement Council for The University of Akron from 2002 to 2004 and is currently serving as Secretary of The University of Akron Electrical Engineering and Computer Engineering Advisory Council as Vice Chairman.

Jim is a LEED v2 Accredited Professional and is registered in the State of Ohio, West Virginia, Pennsylvania and Indiana.

In 2005, Jim received his Lighting Certification (LC) from the National Council on Qualifications for Lighting Professionals (NCQLP).

In 2009, Jim received his Certified Building Commissioning Professional (CBCP) administered by the AEE (Association of Energy Engineers).

KEVIN M. NOBLE, P.E., LEED AP PRINCIPAL – CIVIL / PLUMBING ENGINEERING

PERSONAL RESUME

Mr. Noble attended the University of Akron where he received his Bachelor of Science degree in Civil Engineering in 1987 and continued his education through night school to receive his Masters of Business Administration from Averett College in 1991.

After graduating with a Civil Engineer degree, Mr. Noble accepted a position as a Water Resource Engineer at Dewberry & Davis, Inc., a top fifty engineering firm located in Washington, D.C. Mr. Noble was assigned to work on the firm's contract with the Federal Emergency Management Agency. His responsibilities included hydrologic and hydraulic analyses, flood plain delineations and storm water management facilities. Prior to leaving the company, he was promoted to project manager where he obtained valuable experiences in hydraulics and storm water control from projects involving the U.S. Army Corp of Engineers and Tennessee Valley Authority.

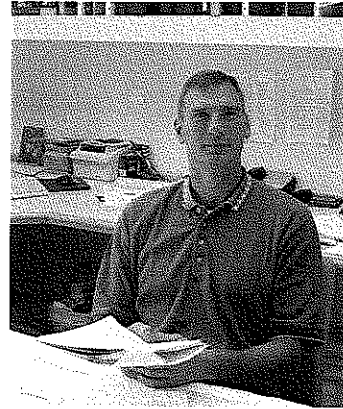

From Washington, D.C., Mr. Noble joined the staff of Elewski & Associates, Inc., a municipal civil engineering firm located in Independence, Ohio. There, he engineered a wide range of residential, commercial and industrial development projects and provided field support to facilitate timely completion of construction. Projects included public and private schools, athletic facilities, planned residential developments, multi-phased office parks, municipal building and retail centers. The site engineering involved design of water mains and pumps, sanitary sewers, force mains, pump stations and storm sewer and stormwater management systems. Prior to leaving, he was promoted to Village Engineer, in charge of plan review, infrastructure design, public work projects and construction inspection.

Mr. Noble joined Scheeser Buckley Mayfield LLC in early 1995 as a department head. Since that time he has participated and managed the design of numerous private and public civil and plumbing projects, including prisons, healthcare, utility companies, universities, municipalities, churches, schools and Federal Government. He attends local and national plumbing and civil conventions and seminars to stay in tune with current developing technologies.

He is registered in the State of Ohio, the State of West Virginia, the State of Florida, the State of South Carolina, the Commonwealth of Virginia and the Commonwealth of Kentucky and is a member of the American Society of Civil Engineers and American Society of Plumbing Engineers.

SCHEESER BUCKLEY MAYFIELD LLC

CORRECTIONAL FACILITY EXPERIENCE

West Virginia Department of Corrections Denmar Correction New Electrical Service Study

Scheeser Buckley Mayfield performed an electrical study for the facility to provide recommendations for ways to improve the system to make it safer, more reliable, and code compliant. The study included a site visit in order to determine the existing conditions, along with a report detailing the existing conditions along with options and recommendations with construction cost estimates and one-line diagrams. Some of these options included ways to eliminate the existing generator/transformer set-up on the primary lines, and provide a new generator and distribution system and back-fed existing loads. Another option was to upgrade wiring on the existing 1930's building. Many options also included ways to give the campus more capacity on the system in order to accommodate possible future air-conditioning loads. Options also included ways to eliminate the multiple incoming services into the same building, and have one main service into each building where possible.

West Virginia Department of Corrections Denmar Correction Kitchen/Dining

The project consisted of the addition of a new kitchen area along with a staff dining area, restrooms, office and a few storage rooms. New 2x4 acrylic fixtures were provided throughout the space with general strip fixtures in storage rooms. New smoke detectors were installed along with fire alarm audio/visual devices throughout the space. The existing electrical service was revised in order to upgrade the existing system to be code compliant. A new 400A, 240V/3 phase/3 wire MDP was installed and the existing kitchen area panelboard was back-fed from the new distribution system. A new 250A, 240V/3 phase panelboard was installed to feed the new 3 phase kitchen equipment loads, along with a new 200A, 120/240V, 1 phase panelboard to feed the 1 phase loads. The new distribution system also back-fed existing 240V, 3 phase loads and existing 120/240V, 1 phase loads, through a 75KVA transformer.

St. Mary's Correctional Facility Dining Hall Additions and Renovations

The project consisted of 2500 sq ft of new additions for the expansion of the existing dining room and storage spaces. The existing 8800 sq ft building that contained a dining room, kitchen, offices, and storage space was renovated. The HVAC design involved the installation of a rooftop unit to serve the new and existing dining room. Ductless split system heat pumps were installed to serve existing office spaces. Packaged terminal air conditioning units were used in the storage rooms. Plumbing design involved relocating site storm piping to accommodate the additions. A restroom was added to the building, one existing restroom was renovated, and a new water service was installed under the project. A dry pipe fire protection system was installed under the project as the existing building was not sprinkled. The system required a new fire service entrance and associated dry pipe system trim. New 2x4 acrylic lighting was installed in the kitchen and dining areas. A new 600A, 208/120V, 3-phase, 4W MDP was designed and fed from the existing MDP. This new MDP then backfed branch circuit panelboards, along with a new 200A, 120/208V, 3-phase, 4W panelboard, which fed new mechanical loads along with some branch circuits for lighting and receptacles. The new HVAC unit was also fed from this panelboard. New kitchen equipment was fed from existing panelboards. A new fire alarm system was installed throughout the new space. New telecommunications was provided in the new space, along with tying existing campus buildings together.

**Huttonsville Correctional Institution
Dormitory Addition and Fire Alarm Upgrade
Huttonsville, WV**

Scheeser Buckley Mayfield LLC provided HVAC, plumbing, and electrical design for the renovation and expansion of two dormitory wings as well as expansion of fire alarm systems at Huttonsville Correctional Institution. Electrical design included lighting, power and systems for the new dormitory. This power design included the coordination of a new utility service as well as installation of backup power for the renovated dormitories. The backup power consisted of a new diesel generator near the dorms and automatic transfer switches/distribution to support the facility. Additional aspects to the design included rework of existing salleyport entrance to the facility, Security systems including door hardware set requirements were integrated into the design for the dormitory. Fire alarm systems for the renovated dormitories were connected to the facility wide fire alarm system via a fire alarm network. This facility wide campus network was upgraded in order to allow a fully integrated system which could be monitored at Master Control. A large number of fire alarm signaling devices (smoke detectors, heat detectors, pullstations, strobes, etc.) were added throughout the facility to ensure that the facility complied with current fire alarm code.

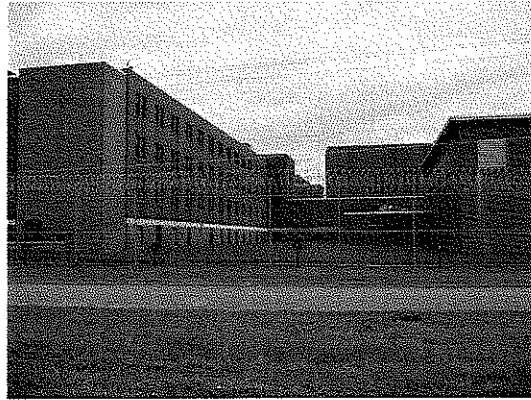

A new heating/cooling system was installed to replace the existing heating only system consisting of steam and condensate risers located throughout the resident areas. The new HVAC design includes multiple constant volume DX cooling rooftop air handling units to serve the new resident areas. The new



air handling units do not contain heat, but are supplemented with hot water reheat coils located throughout the spaces. A steam to hot water heat exchanger with associated heating water pump and condensate pump located in the basement of each new resident wing provides the heating water for the reheat coils. The steam and condensate utilized in the new heating water system originate in the main mechanical room with services extended to the new resident wings. The design of the airside system includes security diffusers and grilles along with security bars located throughout the spaces at designated security walls. Due to limited spacing in the plumbing/HVAC chases for each resident room, coordination of mechanical, electrical, plumbing and fire protection services was critical.

**Huttonsville Correctional Institution
Boiler Replacement
Huttonsville, WV**

Scheeser Buckley Mayfield LLC provided electrical design associated with the installation of replacement boilers serving the facility. The electrical renovation included rework of an existing feeder and replacement of existing distribution in the boiler plant to support the new equipment. Lighting in the boiler plant was also replaced as part of the project.

Huttonsville Correctional Institution
Kitchen Renovation
Huttonsville, WV

Scheeser Buckley Mayfield LLC provided plumbing and electrical design associated with the renovation of the existing kitchen. The renovation included the removal and replacement of approximately 60% of the floor under the kitchen area of the building. The electrical renovation included replacement of existing distribution and branch panels in the renovated space, demolition and refeeding of branch circuits serving existing and new kitchen equipment, and rework of existing branch circuiting which could be reused to refeed equipment. Prior to the work associated with the demolition and renovation, a temporary kitchen was installed at the site. This involved the installation of a temporary utility service, and temporary power distribution to multiple trailers housing serving lines, dishwashing lines, and food prep areas.

The Kitchen Renovation required a major shut-down due to the replacement of the kitchen floor slab. This required a temporary kitchen be set in place consisting of leased trailers which required temporary domestic water and sanitary service. The plumbing design within the kitchen consisted of completely removing all equipment and associated plumbing utilities. Once the floor slab was repaired, the kitchen equipment was reinstalled with new plumbing service. The new plumbing work consisted of providing the existing and new kitchen equipment with the required connections and to meet and update the requirements of the local health department. The design included reworking the existing steam system, install mixing valves to provide tempered water at hand washing sinks, and extending all kitchen equipment with grease laden waste through the existing grease filtering system.

London Correctional Institution
New Power Substation Improvement
Columbus, OH

The project includes the design and installation of a new 69 kV to 13.2 kV electric substation outside the facilities boundary fence. The new substation will be located in the existing well field. The old substation is scheduled to be torn down and removed under this project. The substation design is of the low profile type and include voltage regulators and automatic power factor correction capacitor banks. The installation of the regulators will help correct low voltage conditions the facility is experiencing. The substation will have two transformers with a secondary tie at the 13.2 kV level. One transformer would serve the London Facility and the second transformer would serve the Madison Facility. The substation secondary tie will permit feeding all substation loads in the event one of the transformers failed or was taken off line for maintenance. The design of the substation includes a 13.2 kv switchgear house to enclose the substation's 13.2 kV switchgear. This is being done to improve reliability and ease of maintenance of the substation's 13.2 kV switchgear. The design of the new substation will cover the extension of the existing 69 kV line to the substation as well as the installation of new 13.2 kV underground feeders to refeed the existing substation's London and Madison facility loads. The project will also include the design of a small section of underground ductbank so that a small section of 2400 volt, 3-phase overhead wiring that crosses over the perimeter fence can be placed underground. The project includes the design of two (2) new 13.2 kV electric services for the Police Academy and the BCI building that would be tapped off the existing Madison overhead feeder. Each service would have separate submetering.

**Stevens Correctional Facility
Welch, West Virginia**

The project consisted of converting approximately 100,000 square feet of former health care space into a 300 bed correction center. The HVAC system consisted of multiple packaged roof top units zone to provide zoning and a smoke removal system to provide the required floor pressurization along with the required ventilation for the kitchen. The domestic hot water system consisted of a centralized gas fired storage system with a master mixing valve assembly and a recalculating pump. The electrical system included a diesel generator providing back up power for all Life Safety systems and for the building HVAC system.

**Mount Olive Correctional Facility
Command and Training Facility
Mt. Olive, WV**

Scheeser-Buckley-Mayfield LLC provided mechanical, electrical, plumbing, and fire protection design services for this 4,000 sq. ft. training center. The project included an open area for group training as well as support spaces including offices, storage areas, command center, and an armory area.

**Mount Olive Correctional Facility
New Substation
Mt. Olive, WV**

The project consists of the design of a new 34.5kV to 12.47kV electric substation outside the facilities' boundary fence to replace the facilities' trouble prone 34.5KV distribution system. Drawings and Specifications are being prepared for the installation of a new electric substation, the replacement of the facilities' padmount transformers, and the underground high voltage cable loop feeding the transformers. The substation design is the low profile type and includes voltage regulation. Heating and ventilation systems for the switchgear house are provided.

The substation will have two transformers with a secondary tie at the 12.47 KV level. The substation secondary tie would permit feeding all substation loads in the event one of the transformers fails or is taken off line for maintenance. The design of the substation includes a 12.47 KV switchgear house to enclose the substation's 12.47kV switchgear. This is being done to improve reliability and ease of maintenance of the substation's switchgear. Project design will cover the extension of the existing 35 KV power company line to the new substation.

The project presents a design challenge in the area of substation grounding as the facility is on the top of a mountain in a reclaimed mine area having suspect soil conditions that can adversely affect a good grounding installation. The project presents challenges in interfacing with the facilities' standby power system as the system is old and interfaced with the distribution system in an unconventional manner. An additional design challenge is to maintain power to each of the facility buildings during the construction of the project. This will be taken care of by starting at one end of the facilities 34.5kV loop and reconnecting each padmount transformer on a one by one basis to the new 12.47kV distribution loop. A temporary generator will be connected to each building as its associated padmount transformer is replaced.

Multi-County Juvenile Attention Center

Scheeser Buckley Mayfield LLC performed mechanical and electrical design engineering services for a new 37,000 square foot facility. The building was designed to house 36 high security inmates and 20 inmates at a lower level of security. All inmates will live in the building full-time and the building was designed for a 24 x 7 occupancy. Included in the design of the building was a complete kitchen and dining area. In addition to serving the inmates, staff would also be served by the kitchen. The kitchen and dining area were totally air-conditioned. Kitchen exhaust systems included the use of a UL approved reduced flow kitchen hood and special fire suppression system for the kitchen hood. HVAC systems for the building included VAV and constant volume air systems along with hydronic perimeter heating systems. Smoke exhaust systems were also designed in areas where overnight occupancy is required. The entire building is controlled with a DDC control system which allows for remote monitoring for all mechanical systems. The plumbing design for the building included specialized fixtures for hostile prison environment. Plumbing also included special connections to multiple pieces of kitchen equipment.

Electrical design included low voltage remote relay controlled lighting for nighttime group shutdown. Lighting control features are integrated with the security system for remote emergency operations. All lighting fixtures in the facility are security type design. An addressable fire alarm system was also integrated with the security system for controlled exit/release of residents. All HVAC systems, egress lighting and the complete courtroom area are supported by an exterior diesel generator in the event of a utility outage. In addition, the entire security system is supported by an uninterruptible power supply (UPS) system for uninterrupted monitoring. Elevator design included power wiring for each elevator controller from the buildings distribution system as well as cab lighting. Elevator breakers were provided with shunt trip capabilities if the shafts, machine rooms and pits were sprinklered. Controllers were also tied in to the building fire alarm system as required for elevator recall (fireman's service functions). All functions were designed to NFPA, OBBC and ANSI/ASME codes and requirements that were applicable at the time of design.

Pickaway Correctional Institution Dormitories

Scheeser Buckley Mayfield LLC provided HVAC, plumbing, electrical and civil design for two 38,000 sq ft, two-story dormitories for Pickaway Correctional Institution. The buildings are equipped with steam heat exchangers, hot water heating, ventilation systems with smoke purge controls, and full direct digital control systems. Site civil includes a shallow tunnel approximately 750 feet long housing new steam and condensate mains for the new buildings. Steam and condensate mains utilized ball joints and expansion compensators. SBM was also responsible for the design of the tie-in to the existing mains and required modifications to the existing piping which is fed from a central boiler plant. Electrical design includes lighting, power, and security systems for the two dorm buildings. Each building is serviced electrically by tying into the existing 13,200V high voltage loop system currently in service on the campus as well as via a new 750KVA transformer that splits the power between the two buildings. Emergency power is also being provided to each building through a common 200KW, 208V, 3 phase generator. Low voltage switching was utilized for lighting control throughout the building. In addition to interior lighting, exterior building and site lighting was also incorporated into the design. The security system is a state-of-the art touch-screen system that matches the current security system and allows for security control and integration throughout other areas of the campus. Additional site design included upgrades to the sanitary, storm and water system that were extended through the campus setting, site clearing and grading, erosion control plan and narratives, and vehicular and pedestrian access.

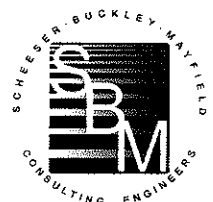

SHELLEY

METZ

BAUMANN

HAWK



STRUCTURAL ENGINEERING

Shelley Metz Baumann Hawk, Inc. specializes in providing structural engineering services for architects, contractors and building owners. Our commitment to providing quality service since 1972 has resulted in exceptional experience with all project types including:

- Educational
- Institutional
- Residential
- Commercial
- Recreational
- Industrial & Distribution Centers
- Healthcare
- Public Projects

As a full service structural engineering firm **Shelley Metz Baumann Hawk, Inc.** provides the following services:

- Design and documentation of building projects including new construction and renovations
- Assessment and Analysis of existing structural systems
- Failure Analysis and Investigations
- Expert Witness Testimony
- Foundation Systems
- Feasibility Studies
- Code Analysis

The firm and individual staff members are committed to providing high quality service. The key to success of any project is balancing design, functionality and costs. We work closely with our clients to ensure that the structural design compliments each building.

Our staff of 22 includes, 10 registered engineers, 5 design engineers, 4 CAD specialists, and 3 administrative assistants. Four of our engineers are LEED Accredited Professionals.

The leadership team of **Shelley Metz Baumann Hawk, Inc.** has over 185 years of combined experience in structural design.

Shelley Metz Baumann Hawk, Inc. enjoys the challenge of developing creative structural engineering solutions.

We listen to our clients.





Robert A. Baumann, PE - Vice President
Shelley Metz Baumann Hawk, Inc.
Project Responsibility: Project Manager

DEGREES/REGISTRATION/EXPERIENCE

Bachelor of Science
Master of Science

Civil Engineering, University of Cincinnati 1980
Civil Engineering, University of Cincinnati 1981

Registration

West Virginia, Rhode Island, Washington, South Carolina, Oregon, Ohio,
Nevada, Nebraska, Kentucky, Iowa, Georgia

Member

American Concrete Institute
American Concrete Institute - Central Ohio Chapter
American Council of Engineering Companies (ACEC)
American Forest & Paper Association
American Institute of Architects
American Institute of Architects - West Virginia Chapter
American Institute of Steel Construction (AISC)
American Society of Civil Engineers (ASCE)
St. Elizabeth Church-Finance Committee Chairman
Structural Engineers Association of Ohio (SEAOO)
Tilt-Up Concrete Association

BACKGROUND EXPERIENCE

Mr. Baumann has been employed in the consulting structural engineering business since 1981. His prior office and field experience with a registered land surveyor contributes to his knowledge of the design and construction process. His work experience with a general contractor included the construction of building types built of reinforced concrete, steel, wood, masonry and precast concrete. Mr. Baumann has designed new buildings as well as additions and large renovation projects.

Mr. Baumann is experienced in the design of structures built from many types of construction materials including post tensioned concrete. His many years of experience allow him to design innovative, economical, and serviceable structures. Mr. Baumann is experienced in investigative work for adaptive reuse of existing structures. He has provided field observation during construction of many of the projects that he has designed.

PROJECT RESPONSIBILITIES

As Project Manager, Bob will provide design input during the conceptual and schematic design phases. Bob will lead the scheduling of the project and coordinate with the Project Engineer for the design and production of the construction documents. He will be involved with the project from beginning to end.

Representative Experience

Shelley Metz Baumann Hawk, Inc.

Photos courtesy of Silling Associates, Inc.

☒ Dining Addition

St. Marys Correctional Center

The dining addition expanded the food service facilities at the medium security prison. The expanded seating allows the 450 inmates to be fed in three shifts.

St. Marys, West Virginia

Construction Cost: \$200,000

Completion Date: 2005

☒ Phase III - Administration Building Renovations

St. Mary's Correctional Center

St. Mary's Correctional Center is a medium security facility for adult male felons. Specialized facilities for geriatric or chronically ill inmates are available on site. The renovations of the administration building accommodates staff supervising approximately 700 inmates.

St. Mary's, West Virginia

Construction Cost: \$8,000,000

Completion Date: 2001

☒ Corrections at St. Mary's

St. Mary's, West Virginia

Construction Cost: \$500,000

Completion Date: 1999

☒ Cell Block Addition (Housing Units)

Huttonsville Correctional Facility

The existing facility had military style dormitories for the inmates. This existing space was reconfigured in conjunction with a single-cell type house addition to enlarge the facility. Each level added had an outdoor fenced balcony for inmate exercise.

Huttonsville, West Virginia

Construction Cost: \$10,000,000

Completion Date: 2005

☒ Boiler Room Slab - Cell Block Addition

Huttonsville Correctional Facility

Huttonsville, West Virginia

Construction Cost: \$2,000,000

Completion Date: 2007

☒ Work Camp

Huttonsville Correctional Center

This 6,000 square foot facility provides a work camp for forty inmates meeting all needs including sleeping, eating, recreation and personal hygiene.

Construction Cost: \$675,000

Completion Date: 2009



Huttonsville Correctional Center

The Huttonsville Correctional Center – located near Huttonsville, West Virginia in Randolph County – is considered a medium security

prison. In 1999, two three-story medium security cell block housing units were added to provide additional space. The units were constructed in the abandoned exercise yard and include 240 beds. Further additions and renovations included the laundry, chapel, medical and dental facilities as well as upgrades to the electronic security. In 2005, SMBH was retained to provide structural design and documentation for new building renovations as well as an assessment and analysis of existing structural systems. In their design and assessment, SMBH had to closely review the extra detailing needed to meet the requirements of the correction authority. All construction had to be consistent with the building codes along with an additional scope of services to provide security to resist destruction and escape. Existing three-story units were expanded laterally so that the units could be reconfigured into two-man and six-man cells. These changes allowed for a safer and more efficient operation of the unit as well as an increase in bed count by 200, bringing the overall capacity to 890. New indoor and outdoor day rooms and shower facilities also were added and are now visible from the new supervision stations.

Huttonsville, West Virginia

Construction Cost: \$17,000,000

Completion Date: 1999

☒ Beckley Federal Correctional Institution

Medium Security facility housing male inmates, visitors building, and the industries building.

Construction Cost: \$72,000,000.

Beckley, West Virginia

Construction Cost: \$72,000,000

Completion Date: 1995

Representative Experience

Shelley Metz Baumann Hawk, Inc.

Photos courtesy of Silling Associates, Inc.

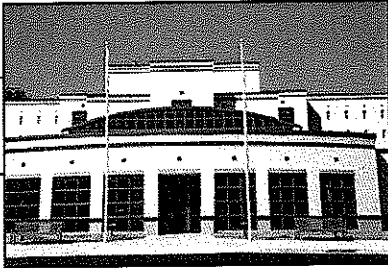

West Virginia Industrial Home for Youth

This 200-bed facility houses both male and female juvenile offenders. The inmates are classified into six categories with respect to their offense and the required level of security. The facility occurs on multiple levels with support for educational, recreational, dining and administrative functions. The facility accommodates the separation of genders and inmate classifications with a shared use without compromising security. Classrooms and labs for computer training, business education, food preparation, construction technology and building maintenance are included inside the facility. The ornamental stone detailing reflects the architecture of buildings on the grounds.

Industrial, West Virginia

Construction Cost: \$20,000,000

Completion Date: 2000

Law Enforcement Center Guernsey County

Combined detention facility and sheriffs office. Primarily one-story structure with concrete frame and precast planks at the detention facility. The sheriffs offices are steel frame construction.

Cambridge, Ohio

Construction Cost: \$6,000,000

Completion Date: 1994

South Central Juvenile Correction Center

This juvenile correction center was a masonry and composite concrete metal deck structure. The addition included training areas, residential areas and security monitoring stations.

Chillicothe, Ohio

Construction Cost: \$5,000,000

Completion Date: 2002

Mt. Olive Correctional Center - Fayette County

The Mount Olive Correctional Complex is a new reformatory prison facility that includes provision for maximum, medium, and minimum security inmates. The multi-building complex provides housing, classification, treatment, services, education, and work opportunity for 800 inmates in separate populations.

Montgomery, West Virginia

Construction Cost: \$50,000,000

Completion Date: 1994

Command Center Mt. Olive Correctional Center

The Command Center is a 3,750 square foot stand-alone facility for training and support of the facility's corrections officers. The building contains an armory for weapons storage. This building provides an additional level of control and security for monitoring the inmates in the maximum security facility.

Wheeling, West Virginia

Construction Cost: \$500,000

Completion Date: 2008

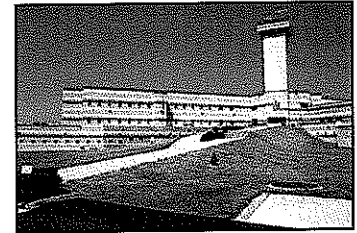

Main Entry/Visitor's Center - Stevens Correctional Facility

This project is the conversion a former hospital into a state correctional facility. Renovations and additions resulted in housing for 334 inmates and support facilities including classrooms, administration, medical, kitchen and dining, and laundry. Each wing of the four-story 1976 building became a housing unit consisting of 46 inmates in double-bunk cells constructed of CMU. Each housing unit shares a secure indirect supervision unit that promotes efficient staffing and inmate control. Dining, education and administration are located on the ground floor in captured open vehicular circulation space beneath the wings of the 1976 building. Vertical inmate movement and perimeter building/site security is monitored by a

master control unit strategically located on the ground floor in the heart of inmate circulation. Master control has direct visual observation of visitation, outdoor recreation, dining and education entrance. The facility features state of the art electronic security video surveillance and perimeter

management system. The project features a total reconstruction of all interior architectural, mechanical, electrical, fire protection, and communications systems into the shell of the abandoned hospital.

Weich, West Virginia

Construction Cost: \$12,000,000

Completion Date: 2005



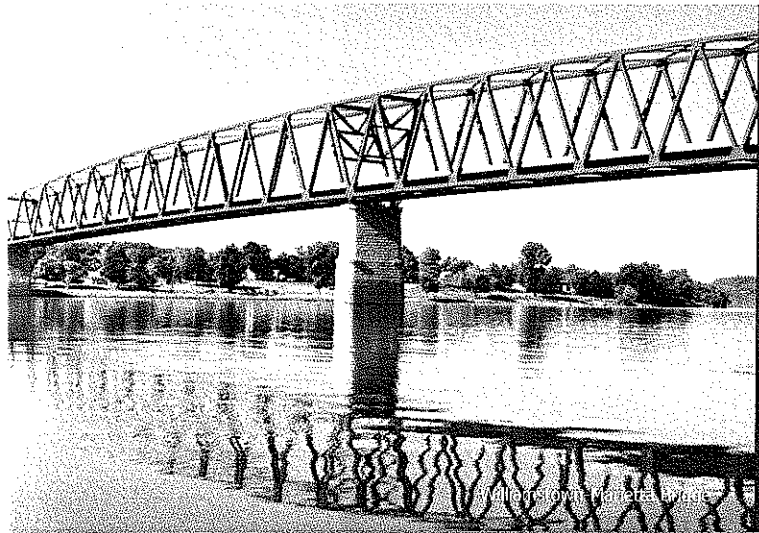

Engineering Solutions
Environmental Stewardship
Community Enhancement

GAI Consultants, Inc. - Corporate Profile

Transforming Ideas Into Reality

What We Do

GAI Consultants, Inc. delivers professional and personalized consulting in the fields of engineering, planning, environmental, and construction services. Our clients are provided exceptional value through full-service capabilities, state-of-the-art design, and talented, experienced staff.

Our primary service areas address project conception through construction, and meet the needs of our clients in five targeted market sectors.

Primary Market Sectors

Government

Maintaining our nation's infrastructure and national security are top concerns in today's government market. Whether at the federal, state, or local level, government agencies continually find themselves understaffed, overburdened, and under funded. Yet they are expected to fulfill their duties and meet the growing needs of the public whether designing flood control measures or providing environmental compliance services. GAI constantly scans and analyzes the needs of the government market sector to assist our government clients in meeting the needs of the public and in achieving their goals. We act as an extension to the governments' team of professionals. We are able to accomplish this in an efficient manner through providing the "best value" to the government by deploying our skilled professionals to perform specialized services, or by providing a full range of services.

Real Estate

The competitive world of private land development and real estate has created an ever-growing need for fast, accurate, and cost-effective information on which to base critical business decisions. We understand the importance of this information to public and private developers and, in response, provide our clients with a full range of professional services for all stages of the development life cycle - from initial concept, through planning, investigation, design, construction,

commissioning, operations, and maintenance. Our goal is to present real solutions to today's most prevalent development challenges by focusing on quality service and achieving the greatest return on our clients' investment dollars.

Transportation

The need for expanded and improved transportation systems at the state and local levels is continually increasing, while federal funding is under constant pressure. This requires state and local transportation agencies to discover new and inventive ways to reduce costs and overhead, while improving efficiency. Through cooperation and innovation we are assisting our transportation clients with everything from preliminary to final design services by fostering public/private partnerships that lead to cost savings, improved quality, accommodation of peak demand, better managed risks, technology sharing, and faster project delivery. Our goal is to enter into these partnerships by assisting our transportation clients and providing them with the support and expertise necessary to meet the transportation-related infrastructure demands of thriving economies.

Energy

Meeting the demands of the ever-increasing energy consuming public, as well as the regulatory requirements of the government, presents specific challenges to the various energy utilities. To be successful, companies involved with the production and transmission of energy products must provide reliable and low cost output to survive. GAI provides expertise, guidance, and a comprehensive support system that enables our clients to make informed decisions and successfully navigate the challenges of this highly regulated and competitive market. Our goal is that through sound information and guidance on items such as coal combustion byproduct disposition and transmission line siting, we will alleviate the regulatory burden that our clients face, while providing them with the ability to remain competitive within their market.

Industry

The industrial market, as well as the industrial processing and manufacturing of various consumable goods, continues to play a vital role in the growth and stability of our national economy. Due to the effects of the global economy, industry in the United States must remain competitive through increased efficiency and tight cost-control measures. GAI fully understands the constraints faced by the industrial sector, especially the high cost of regulatory compliance with federal, state, and local mandates. Our goal is to partner with our industrial clients in an all-out effort to remain competitive by providing them with the expertise necessary, such as environmental compliance, or structural analysis, to effectively and efficiently comply with the various regulatory bodies as well as make informed and cost-effective decisions regarding their operational and infrastructure needs.

Primary Service Areas

Land Development and Planning

- Site Selection and Design
- Land Use Studies, Economic Feasibility, and Site Planning
- Community and Regional Planning
- Planning and Engineering Approvals/Permitting
- Land Surveying and Construction Layout
- Code Impact Assessment and Permit Acquisition
- Facilities Planning and Infrastructure Design
- Landscape Architecture and Streetscape Design

Construction Engineering and Inspection

- Construction Monitoring and Inspection
- Constructability Reviews
- Materials Testing
- CPM Scheduling and Reporting
- Innovative Construction Management
- Utility Construction Coordination

Environmental Engineering, Sciences, & Remediation

- Hydrogeologic and Hydraulic Studies and Design
- Ground-water Modeling and Monitoring
- Water and Wastewater Treatment Systems
- Flood Control and Coastal Studies
- Solid and Hazardous Waste Management Design
- Industrial Hygiene and Safety Compliance
- Environmental Impact Statements and Assessments
- Wetland Delineation, Watershed and Stream Restoration, Threatened and Endangered Species
- Gas and Electric Transmission Line Siting
- Geographic Information Systems (GIS) Mapping and Information Management

Transportation Planning and Design

- Bridge, Highway, and Roadway Design
- Bridge Inspection and Rehabilitation
- Transportation Planning and Transit Studies
- Airport Facilities Design and Reconstruction
- Traffic Studies and Traffic Control Plans
- Eminent Domain Consultation
- Public and Private Agency Coordination
- NEPA / Section 4f Studies / Section 106 Studies

Geotechnical and Structural Engineering

- Dam Rehabilitation and Design
- Transmission Line Design
- Geologic Studies and Subsurface Explorations
- Subsidence Studies and Remediation
- Mining Engineering and Mine Fire Abatement
- Vibration, Seismic, and Structural Reliability Studies
- Slope Stabilization Analysis and Design
- Foundation Research and Design
- Earth and Rock Retaining Structure Design
- Structural Rehabilitation

Cultural Resources and Historic Preservation

- Historic Architectural Surveys and Context Studies
- Comprehensive Historic Preservation Plans
- Geographic Information Systems Predictive Modeling
- Prehistoric, Historical and Urban Archaeology
- Phase I, II, and III Surveys and Mitigation
- Public Outreach Programs
- Geomorphology, Pedology, and Soils Surveys
- National Register Inventories and Evaluations

Our Clients. We take great pride in serving both public and private sector clients with whom we have developed long-term relationships. These include public utilities, transportation departments, federal, state and local governments, private developers, and private corporations.

Our People. Our employee-owned firm consists of a team of more than 450 highly dedicated and talented engineers, scientists, planners, environmental specialists, construction specialists, and support staff that are known for their solid professional reputations, and personalized quality service.

Our Ideals. Built on 45 years of a strong vision and mission, GAI's ethics, principles, and core values guide us and our work. We are committed to the success of our clients and our employees. Quality, respect, innovation, and teamwork are the values that drive our company.

Our Work. Simply put, we are in this business to deliver successful projects to our clients, and to help them exceed the expectations of the communities that they serve.

Pittsburgh, PA
412.476.2000

Jacksonville, FL
904.363.1110

Charleston, WV
304.926.8100

Philadelphia, PA
610.640.7456

Orlando, FL
407.423.8398

Fort Wayne, IN
260.625.4155

Richmond, VA
804.360.5893

*For more information on
GAI Consultants, Inc., please visit
www.gaiconsultants.com or
call 1.800.292.6076*

James Hemme, P.E., L.R.S.

Senior Engineering Manager

Education

B.S. Civil Engineering, 1989 West Virginia University Institute of Technology
Marshall University Graduate College – Various Courses in Environmental Engineering

Registrations

West Virginia Professional Engineer No. 12195
Kentucky Professional Engineer No. 25437
Ohio Professional Engineer No. 72851
Indiana Professional Engineer No. 10809277
Pennsylvania Professional Engineer No. 75494
New York Professional Engineer No. 85794
West Virginia Licensed Remediation Specialist No. 003

Professional Development

OSHA 40 hour Hazwopper Training
NICET 1 – Geosynthetics Installation Inspection (expired)
Nuclear Density Gage Training – DOT and NRC (expired)
MSHA Safety Training (expired)

Awards

- National Radio Astronomy Observatory (NRAO) Wastewater Treatment Plant Design (Project Manager) – WV ACEC Gold Award
- Florida Street Streetscape Masterplan (Senior Engineer) - WV ASLA Honor Award
- Dupont Hyper Plaza Design (Senior Engineer) – WV ASLA Honor Award
- Kanawha Trestle Rail Trail Masterplan (Project Manager) – WV ASLA Merit Award and WV ACEC Silver Award
- April Dawn Park Sprayground “Teays Valley Monster” (Senior Engineer)–WV ASLA Honor Award and WV ACEC Gold Award
- Coldwater Creek Distribution Center Site Preparation (Project Manager) – WV ACEC Gold Award

Professional Experience

Mr. Hemme has a wide variety of experience with correctional and judicial projects and other environmental, civil engineering, site development, streetscape, and planning projects while at GAI and through previous employment. He has worked extensively with private developers, architects, municipalities and governmental agencies. He is an expert in site engineering, NEPA compliance and storm water management. He has worked on landfills, quarries, mines, industrial, and commercial facilities. He has performed many Phase 1 environmental site assessments; solid waste, industrial waste, erosion and sediment control permitting; designed extensive storm water management systems; designed both large and small site developments ranging from 1 acres to hundreds of acres in size; designed wetland mitigation areas; assisted in the preparation of geotechnical reports; flood plain modeling, highway/roadway design, right-of-way plans, prepared detailed construction plans and cost estimates for projects ranging from \$10,000 to multiple millions.

Representative Project Experience:

Correctional and Judicial Facilities:

- Huttonsville Work Camp – Project Manager for the site design and permitting associated with the proposed work camp facility to be located across Rt. 250 from the maximum security location.

Correctional and Judicial Facilities (continued):

- Huttonsville Correctional Facility – Project Manager for the retrofit design of the current wastewater treatment facility experiencing temperature, grease and trash issues
- Anthony Correctional Center – Project Manager for the design of a package potable water treatment plant for a rural correctional facility running off of springs.
- Morgan County Courthouse Replacement, Berkeley Springs, WV – Senior Engineering Manager for site design and permitting associated with a new facility in a historic location. Includes the establishment of a TMDL for Warm Springs Run to use the naturally warm water with an innovative HVAC system to supply inexpensive heating and cooling for the facility.
- Greenbrier County Courthouse Annex and Expansion, Lewisburg, WV – Project Manager for the site design development drawings and budgetary cost estimation.
- Raleigh County Courthouse Annex Design, Beckley WV – Urban infill location with coordination of existing structures and utilities.
- Hampshire County Courthouse – Remedial storm water drainage design.
- Pruntytown Correctional Facility – Site design for an emergency generator pad and maintenance access.
- St. Marys Correctional Facility – Environmental investigation to determine if contaminants of concern were present as a potential cause of a K-9 officer illness and fatality at the kennel.
- Correctional Officer Training Academy – Feasibility study to determine siting requirements for a modular training academy building at property located near Ripley WV.

General Engineering and Permitting Experience:

- Site Design for over 100 different projects throughout WV, OH, KY and PA
- Design of over 50 storm water management systems
- Detailed design of over 100 different ponds, embankments and lagoons
- Preparation of over 100 detailed erosion and sediment control plans
- Preparation of over 100 NPDES Construction Storm water Permit Applications
- NEPA compliance for wetlands, streams, cultural resources, endangered species, etc.
- Phase 1 Environmental Site Assessments for a wide range of facilities

Site Development and Planning:

- Chesapeake Energy Regional Headquarters, Charleston, West Virginia (**LEED Project**)
- Chesapeake Energy Field Office, Jane Lew, West Virginia
- Chesapeake Energy Field Office, Mount Morris, Pennsylvania
- Chesapeake Energy Field Office, Honey Branch, Kentucky
- The Pines Country Club, Morgantown, West Virginia
- Dow Chemical South Charleston Plant – Entrance, Parking and Pedestrian Improvements
- Coldwater Creek Distribution Center and Wetland Mitigation in Parkersburg, WV
- Tamarack Phase 2 Expansion, Beckley, WV
- Marshall University Clinical Outreach and Education Center, Huntington, WV

Business Park and Subdivision Planning:

- Cheat Landing Office Park, Morgantown, West Virginia
- Ft. Boreman Development–Master Plan Site Preparation and Roadway Design, Parkersburg, WV
- The Villages at Cheat Landing, Morgantown, West Virginia
- Almost Heaven Habitat for Humanity – South Fork Crossing Subdivision, Pendleton Co., WV
- Stonegate at Cranberry, Cranberry Township, Pennsylvania

Parks & Recreation:

- Golf Club House and Lodge Site Development at Stonewall Jackson State Park
- Cedar Creek State Park Camp Ground Expansion, Glenville, West Virginia
- Dow Heritage Park, Charleston, West Virginia
- Fort Boreman Historic Park, Parkersburg, West Virginia
- Dupont 'Hyper' Plaza, Belle, West Virginia
- April Dawn Sprayground and Park "Teays Valley Monster"
- Rotary park Improvements, Huntington, WV

Streetscape and Trails:

- Kanawha Trestle and Rail Trail Master Plan
- Florida Street Master Plan for the City of Charleston, West Side Neighborhood Association
- City of Richwood, West Virginia Streetscape Master Plan and Phase 1 Construction
- Phase 1 of the Florida Street Streetscape
- Washington Street East Phase 2 Streetscape, Charleston, WV
- Pennsylvania Avenue Streetscape, Charleston, WV
- City of Charleston, East End Design Cheret
- City of Charleston, "Think Tank" Design Cheret
- Volunteer in preparation of Greater Charleston Greenway Initiative by the WV Land Trust Co.
- Current volunteer with the Riverside South Committee / Charleston Land Trust
- North Bend Rail Trail Flood Damage Repair

Solid Waste Management and Engineering:

- **Design and permitting for 50 different solid waste facilities in WV, VA, OH.**
- Berkeley County Solid Waste Authority – Siting Study regarding suitability of property
- North Fork Landfill – 50 acre landfill over previously deep mined area
- Nicholas County Landfill – Small rural landfill expansion with special steep slope design
- Disposal Service Landfill – Unique multi-stage expansion of a landfill including steep slope design
- Boone County Commission – Permitting of various solid waste transfer stations
- Page County Virginia – Comprehensive Countywide search for a regional landfill
- Anker Energy – Conceptual study to determine feasibility of fly ash disposal facility
- Elkem Metals – Fly ash landfill utilizing a geosynthetic clay liner and special slope design

Waste Water and Potable Water Design:

- National Radio Astronomy Observatory – Design of a unique, non-mechanical, award winning treatment system that uses no electricity and treats the entire campus wastewater load.
- Manufactured Housing Development Waterline Replacement – Design of over 5 miles of water line within an existing 1000+ unit manufactured housing development.
- Pocahontas County Landfill – Modular trickling sand filters with aeration pond and polishing wetland
- Multiple Landfills – Pre-treatment system design to remove high BOD levels prior to WWTP
- Storage Tank Design – Multiple bolted or welded steel tanks primarily for leachate storage

Abandoned Mine Land (AML) Reclamation and Acid Mine Drainage (AMD) Treatment:

- Richard Mine Acid Mine Drainage – Treatment Alternatives Report, Monongalia County, WV
- Richard Mine Flow Monitoring Study – Design, installation, full time flow monitoring and reporting for a 1 year period on drainage from a substantial AMD discharge.
- East Branch Raccoon Creek AMD Treatment Design – ODNR
- Vens Run Landslide Reclamation #2 Design and Permitting – Harrison County, WV
- Whites Run Reclamation Permitting – Randolph County, WV

Environmental Compliance

Correctional Facilities



Huttonsville Correctional Facility Waste Water Treatment Plant Improvements

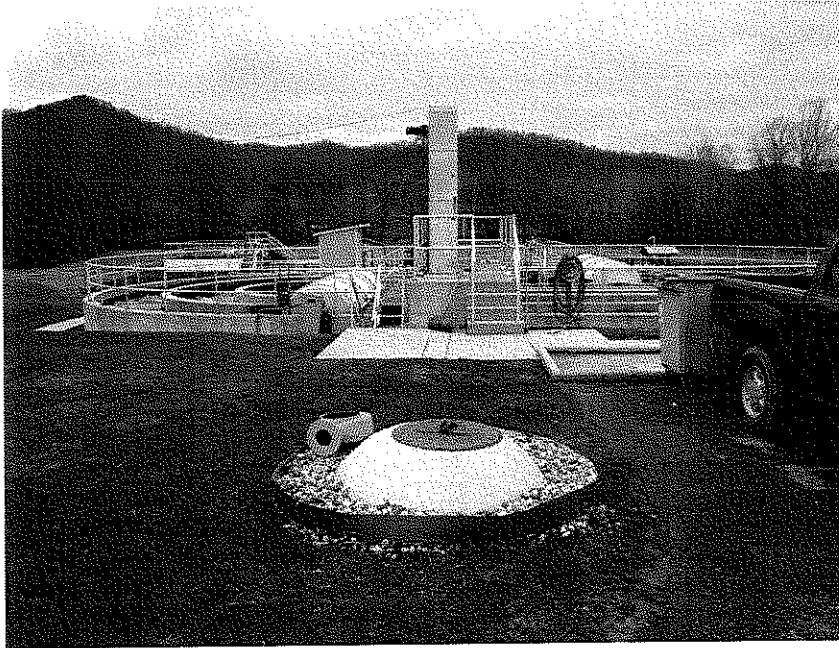

GAI Project Manager:
James Hemme, P.E., L.R.S.

Project Team
Silling Associates, Architects
(Prime)
GAI Consultants, Inc.

Owner:
West Virginia Department
of Corrections

Estimated Completion Date:
Summer 2010

Estimated Construction Cost:
\$450,000

Brief Project Description

GAI Consultants, Inc., through Silling Associates Architects designed process improvements for the existing 200,000 gallon per day wastewater plant for the Huttonsville Correctional Facility located in Randolph county West Virginia.

The existing wastewater plant was constructed in the mid 1990's as part of a large expansion project. Over the past decade increasing monthly flow rates, elevated wastewater temperatures, grease and trash became critical operational concerns. GAI worked with correctional facility staff to explore the root causes of these issues and formulate a retrofit that would not adversely impacting plant operations during construction. GAI initially performed extensive research to compare historical wastewater flow to precipitation events to determine if stormwater inflow and infiltration (I&I) was a contributing factor. Results of that study indicated that I&I was not a substantial contributor to the increased flow.

The solution came in the form of a partially buried concrete surge tank/basin. This 50,000 gallon reinforced concrete surge basin was sized to handle excessive peak flows that had been determined from the historical flow monitoring records. The partially buried tank with open top also provided a stilling basin out of the direct sun to assist in cooling the wastewater. An oil and grease separator was added to the end of the surge basin to remove additional oils and greases. By installing at the end of the tank system, cooling time was maximized to allow the oils and greases to better coalesce and improve removal rates. At the entrance to the surge basin a new screen system was installed to improve removal of the multitude of trash encountered in correctional facility wastewater while still allowing the important organic matter to continue on to the treatment process. The proposed facility has been designed to be constructed adjacent to the existing plant and supplement its operation without impacting the current and successful treatment system.

Environmental Compliance

Correctional Facilities – Potable Water Treatment



Potable Water Treatment Plant for Anthony Correctional Facility

Brief Project Description

GAI Consultants, Inc., through Silling Associates, Architects designed a new potable water treatment plant for the Anthony Correctional Facility in rural Greenbrier County.

The Correctional Facility had operated for years using groundwater from wells and a basic filtration system to provide water for the site. As the wells and filtration system have aged, the level of iron has increased and filtration capacity decreased so a modern treatment system had become necessary. Due to the rural nature and topography surrounding the site, utilizing surface water from nearby Anthony Creek or construction of a water line from a public service district was determined to be infeasible.

GAI designed a system that could treat the daily required water in one 8 hour shift for an operator. This involved one 18,000 gallon raw water storage tank and two parallel 20 GPM packaged water treatment plants with each plant having single stage flocculation, tube settler and mixed media filter and new chemical mixing equipment. The system was set up to use treated water to backwash the filters. The system was also designed to be contained in a simple concrete building that could be brought to the site in two pieces and provide greater security than a standard stick built structure. The plant design provides redundancy and also facilitates maintenance by allowing one plant to be shut down while still maintaining treatment capabilities in the other plant.

GAI Project Manager:
James Hemme, P.E., L.R.S.

Project Team
Silling Associates, Architects
(Prime)

GAI Consultants, Inc.

Owner:
West Virginia Department
of Corrections

Estimated Completion Date:
April 2010

Estimated Construction Cost:
\$550,000

