



State of West Virginia
 Department of Administration
 Purchasing Division
 2019 Washington Street East
 Post Office Box 50130
 Charleston, WV 25305-0130

Request for Quotation

| |
|------------|
| RFO NUMBER |
| AGR1019 |

| |
|------|
| PAGE |
| 1 |

| |
|--|
| ADDRESS CORRESPONDENCE TO ATTENTION OF |
| RON PRICE 304-558-0492 |

RFQ COPY
 TYPE NAME/ADDRESS HERE

PLEASANT AIR HEATING & COOLING, INC.
 5200 Emerson Ave. Parkersburg, WV 26101
 (304)428-5799 (304)684-2323
 WV009708

DEPARTMENT OF AGRICULTURE
 BUILDINGS & GROUNDS DIVISION
 BUILDING 17
 4720 BRENDA LANE
 CHARLESTON, WV
 25312 558-2222

| | | | | |
|--------------|---------------|----------|-----|---------------|
| DATE PRINTED | TERMS OF SALE | SHIP VIA | FOB | FREIGHT TERMS |
| 04/01/2010 | | | | |

BID OPENING DATE: 05/04/2010 BID OPENING TIME 01:30PM

| LINE | QUANTITY | UOP | CAT. NO. | ITEM NUMBER | UNIT PRICE | AMOUNT |
|--|----------|-----|----------|-------------|------------------------------|----------------------|
| 0001 | 1 | LS | | 031-06 | NOTE * SEE ATTACHMENT #16 | \$6530 ⁰⁰ |
| <p>HVAC INSTALLATION</p> <p>TO PROVIDE ALL LABOR AND MATERIALS REQUIRED TO INSTALL NEW HEATING, AIR CONDITIONING AND VENTILATION (HVAC) EQUIPMENT IN SEVEN BUILDINGS LOCATED AT THE GUS R. DOUGLASS AGRICULTURAL CENTER.</p> <p>THIS PROJECT IS PAID FOR WITH FEDERAL FUNDING THROUGH THE AMERICAN RECOVERY AND REINVESTMENT ACT OF 2009.</p> <p>MANDATORY PRE-BID</p> <p>A MANDATORY PRE-BID WILL BE HELD ON 4/13/10 @ 10:00 AT THE J.T. JOHNSON CONFERENCE ROOM AT GUTHRIE CENTER. ALL INTERESTED PARTIES ARE REQUIRED TO ATTEND THIS MEETING. FAILURE TO ATTEND THE MANDATORY PRE-BID SHALL RESULT IN DISQUALIFICATION OF THE BID. NO ONE PERSON MAY REPRESENT MORE THAN ONE BIDDER.</p> <p>AN ATTENDANCE SHEET WILL BE MADE AVAILABLE FOR ALL POTENTIAL BIDDERS TO COMPLETE. THIS WILL SERVE AS THE OFFICIAL DOCUMENT VERIFYING ATTENDANCE AT THE MANDATORY PRE-BID. FAILURE TO PROVIDE YOUR COMPANY AND REPRESENTATIVE NAME ON THE ATTENDANCE SHEET WILL RESULT IN DISQUALIFICATION OF THE BID. THE STATE WILL NOT ACCEPT ANY OTHER DOCUMENTATION TO VERIFY ATTENDANCE. THE BIDDER IS RESPONSIBLE FOR ENSURING THEY HAVE COMPLETED THE INFORMATION REQUIRED ON THE ATTENDANCE SHEET. THE PURCHASING DIVISION AND THE STATE AGENCY WILL NOT ASSUME ANY RESPONSIBILITY FOR A BIDDER'S FAILURE TO COMPLETE THE PRE-BID ATTENDANCE SHEET. IN ADDITION, WE REQUEST THAT ALL POTENTIAL BIDDERS INCLUD</p> | | | | | | |

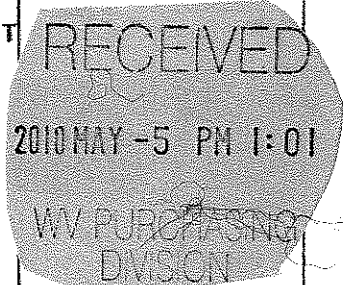

| | | | |
|---|--------------|-----------------------------------|--|
| SEE REVERSE SIDE FOR TERMS AND CONDITIONS | | | |
| SIGNATURE | TELEPHONE | DATE | |
| <i>Robert K. ...</i> | 304-428-5799 | 4-26-10 | |
| TITLE | FEIN | ADDRESS CHANGES TO BE NOTED ABOVE | |
| PRESIDENT | 55-0699312 | | |

WHEN RESPONDING TO RFQ, INSERT NAME AND ADDRESS IN SPACE ABOVE LABELED 'VENDOR'



State of West Virginia
 Department of Administration
 Purchasing Division
 2019 Washington Street East
 Post Office Box 50130
 Charleston, WV 25305-0130

**Request for
 Quotation**

RFQ NUMBER
AGR1019

PAGE
2

ADDRESS CORRESPONDENCE TO ATTENTION OF
**RON PRICE
 304-558-0492**

VENDOR

RFQ COPY
 TYPE NAME/ADDRESS HERE

BUYER

DEPARTMENT OF AGRICULTURE
 BUILDINGS & GROUNDS DIVISION
 BUILDING 17
 4720 BRENDA LANE
 CHARLESTON, WV
 25312 558-2222

| DATE PRINTED | TERMS OF SALE | SHIP VIA | F.O.B. | FREIGHT TERMS |
|--------------|---------------|----------|--------|---------------|
| 04/01/2010 | | | | |

BID OPENING DATE: **05/04/2010** BID OPENING TIME **01:30PM**

| LINE | QUANTITY | UOP | CAT NO | ITEM NUMBER | UNIT PRICE | AMOUNT |
|---|----------|-----|--------|-------------|------------|--------|
| <p>THEIR E-MAIL ADDRESS AND FAX NUMBER.</p> <p>ALL POTENTIAL BIDDERS ARE REQUESTED TO ARRIVE PRIOR TO THE STARTING TIME FOR THE PRE-BID. BIDDERS WHO ARRIVE LATE, BUT PRIOR TO THE DISMISSAL OF THE TECHNICAL PORTION OF THE PRE-BID WILL BE PERMITTED TO SIGN IN. BIDDERS WHO ARRIVE AFTER CONCLUSION OF THE TECHNICAL PORTION OF THE PRE-BID, BUT DURING ANY SUBSEQUENT PART OF THE PRE-BID WILL NOT BE PERMITTED TO SIGN THE ATTENDANCE SHEET.</p> <p>WRITTEN QUESTIONS MAY BE SUBMITTED UNTIL 4:30 PM ON APRIL 20, 2010 TO THE FOLLOWING:</p> <p>RON PRICE PURCHASING DIVISION 2019 WASHINGTON STREET EAST CHARLESTON, WV 25305 FAX: 304-558-4115 EMAIL: RON.N.PRICE@WV.GOV</p> <p>EXHIBIT 5</p> <p>WEST VIRGINIA CODE 21-1D-5 PROVIDES THAT: ANY SOLICITATION FOR A PUBLIC IMPROVEMENT CONSTRUCTION CONTRACT REQUIRES EACH VENDOR THAT SUBMITS A BID FOR THE WORK TO SUBMIT AT THE SAME TIME AN AFFIDAVIT OF COMPLIANCE WITH THE BID. THE ENCLOSED DRUG-FREE WORKPLACE AFFIDAVIT MUST BE SIGNED AND SUBMITTED WITH THE BID AS EVIDENCE OF THE VENDOR'S COMPLIANCE WITH THE PROVISIONS OF ARTICLE 1D, CHAPTER 21 OF THE WEST VIRGINIA CODE. FAILURE TO SUBMIT THE SIGNED DRUG-FREE WORKPLACE AFFIDAVIT WITH THE BID SHALL RESULT IN DISQUALIFICATION OF SUCH BID.</p> <p>NOTICE TO PROCEED: THIS CONTRACT IS TO BE PERFORMED</p> | | | | | | |

SEE REVERSE SIDE FOR TERMS AND CONDITIONS

| | | |
|-----------------------------------|-----------|-----------------------------------|
| SIGNATURE <i>Robert C. ...</i> | TELEPHONE | DATE 4-26-10 |
| TITLE PRES | FEIN | ADDRESS CHANGES TO BE NOTED ABOVE |

WHEN RESPONDING TO RFQ, INSERT NAME AND ADDRESS IN SPACE ABOVE LABELED 'VENDOR'



State of West Virginia
 Department of Administration
 Purchasing Division
 2019 Washington Street East
 Post Office Box 50130
 Charleston, WV 25305-0130

**Request for
 Quotation**

| |
|------------|
| RFQ NUMBER |
| AGR1019 |

| |
|------|
| PAGE |
| 3 |

| |
|--|
| ADDRESS CORRESPONDENCE TO ATTENTION OF |
| RON PRICE 304-558-0492 |

RFQ COPY
 TYPE NAME/ADDRESS HERE

COMPANY

SHIP TO

DEPARTMENT OF AGRICULTURE
 BUILDINGS & GROUNDS DIVISION
 BUILDING 17
 4720 BRENDA LANE
 CHARLESTON, WV
 25312 558-2222

| | | | | |
|------------------------------|---------------|--------------------------|--------|---------------|
| DATE PRINTED | TERMS OF SALE | SHIP VIA | F.O.B. | FREIGHT TERMS |
| 04/01/2010 | | | | |
| BID OPENING DATE: 05/04/2010 | | BID OPENING TIME 01:30PM | | |

| LINE | QUANTITY | UOP | CAT NO | ITEM NUMBER | UNIT PRICE | AMOUNT |
|--|----------|-----|--------|-------------|------------|--------|
| <p>BY AUGUST 2, 2010.</p> <p>CANCELLATION: THE DIRECTOR OF PURCHASING RESERVES THE RIGHT TO CANCEL THIS CONTRACT IMMEDIATELY UPON WRITTEN NOTICE TO THE VENDOR IF THE MATERIALS OR WORKMANSHIP SUPPLIED ARE OF AN INFERIOR QUALITY OR DO NOT CONFORM WITH THE SPECIFICATIONS OF THE BID AND CONTRACT HERE IN.</p> <p>WAGE RATES: THE CONTRACTOR OR SUBCONTRACTOR SHALL PAY THE HIGHER OF THE U.S. DEPARTMENT OF LABOR MINIMUM WAG RATES AS ESTABLISHED FOR KANAWHA COUNTY, PURSUANT TO WEST VIRGINIA CODE 21-5A, ET, SEQ. (PREVAILING WAGE RATES APPLY TO THIS PROJECT)</p> <p>ARBITRATION: ANY REFERENCES MADE TO ARBITRATION OR INTEREST FOR PAYMENTS DUE (EXCEPT FOR ANY INTEREST REQUIRED BY STATE LAW) CONTAINED IN THIS CONTRACT OR IN ANY AMERICAN INSTITUTE OF ARCHITECTS DOCUMENTS PERTAINING TO THIS CONTRACT ARE HEREBY DELETED.</p> <p>WORKERS' COMPENSATION: VENDOR IS REQUIRED TO PROVIDE A CERTIFICATE FROM WORKERS' COMPENSATION IF SUCCESSFUL</p> <p>ALL OF THE ITEMS CHECKED BELOW WILL BE A REQUIREMENT OF THIS CONTRACT:</p> <p><input checked="" type="checkbox"/> INSURANCE: SUCCESSFUL VENDOR SHALL FURNISH PROOF OF COMMERCIAL GENERAL LIABILITY INSURANCE PRIOR TO ISSUANCE OF CONTRACT. UNLESS OTHERWISE SPECIFIED IN THE BID DOCUMENTS, THE MINIMUM AMOUNT OF INSURANCE COVERAGE REQUIRED IS \$250,000.</p> <p><input type="checkbox"/> BUILDERS RISK INSURANCE: SUCCESSFUL VENDOR SHALL FURNISH PROOF OF BUILDERS RISK - ALL RISK INSURANCE IN</p> | | | | | | |

| | | | |
|---|-----------------------------------|---------|--|
| SEE REVERSE SIDE FOR TERMS AND CONDITIONS | | | |
| SIGNATURE | TELEPHONE | DATE | |
| <i>Robert Crutcher</i> | | 4-26-10 | |
| TITLE | ADDRESS CHANGES TO BE NOTED ABOVE | | |
| <i>PRD</i> | | | |

WHEN RESPONDING TO RFQ, INSERT NAME AND ADDRESS IN SPACE ABOVE LABELED 'VENDOR'



State of West Virginia
 Department of Administration
 Purchasing Division
 2019 Washington Street East
 Post Office Box 50130
 Charleston, WV 25305-0130

Request for Quotation

RFQ NUMBER
AGR1019

PAGE
4

ADDRESS CORRESPONDENCE TO ATTENTION OF
RON PRICE
304-558-0492

RFQ COPY
 TYPE NAME/ADDRESS HERE

VENDOR

SHIP TO

DEPARTMENT OF AGRICULTURE
 BUILDINGS & GROUNDS DIVISION
 BUILDING 17
 4720 BRENDA LANE
 CHARLESTON, WV
 25312 558-2222

| DATE PRINTED | TERMS OF SALE | SHIP VIA | FOB | FREIGHT TERMS |
|--------------|---------------|----------|-----|---------------|
| 04/01/2010 | | | | |

BID OPENING DATE: **05/04/2010** BID OPENING TIME **01:30PM**

| LINE | QUANTITY | UOP | CAT NO | ITEM NUMBER | UNIT PRICE | AMOUNT |
|---|----------|-----|--------|-------------|------------|--------|
| | | | | | | |
| <p>AN AMOUNT EQUAL TO 100% OF THE AMOUNT OF THE CONTRACT.</p> <p>(XX) BONDS: FIVE PERCENT (5%) OF THE TOTAL AMOUNT OF THE BID PAYABLE TO THE STATE OF WEST VIRGINIA, SHALL BE SUBMITTED WITH EACH BID AS A BID BOND. THE SUCCESSFUL BIDDER SHALL ALSO FURNISH A PERFORMANCE BOND AND LABOR MATERIAL BOND FOR 100% OF THE AMOUNT OF THE CONTRACT. BONDS MAY BE PROVIDED IN THE FORM OF A CERTIFIED CHECK, IRREVOCABLE LETTER OF CREDIT, OR BOND FURNISHED BY A SOLVENT SURETY COMPANY AUTHORIZED TO DO BUSINESS IN THE STATE OF WEST VIRGINIA. A LETTER OF CREDIT SUBMITTED IN LIEU OF A BOND WILL ONLY BE ALLOWED FOR PROJECTS UNDER \$100,000. PERSONAL OR BUSINESS CHECKS ARE NOT ACCEPTABLE IN LIEU OF THE 5% BID BOND, PERFORMANCE BOND, OR LABOR AND MATERIAL BOND.</p> <p>() MAINTENANCE BOND: A TWO (2) YEAR MAINTENANCE BOND COVERING THE ROOFING SYSTEM WILL BE A REQUIREMENT OF THE SUCCESSFUL VENDOR.</p> <p>REV. 11/00</p> <p>EXHIBIT 7</p> <p>DOMESTIC ALUMINUM, GLASS & STEEL IN PUBLIC WORKS PROJECTS</p> <p>IN ACCORDANCE WITH WEST VIRGINIA CODE 5-19-1 ET., SEQ., EVERY CONTRACT FOR CONSTRUCTION, RECONSTRUCTION, ALTERATION, REPAIR, IMPROVEMENT OR MAINTENANCE OF PUBLIC WORKS, WHERE THE COST IS MORE THAN \$50,000 AND, IN THE CASE OF STEEL ONLY, WHERE THE COST OF STEEL IS MORE THAN \$50,000 OR WHERE MORE THAN 10,000 POUNDS OF STEEL ARE REQUIRED, THE STATE WILL ACCEPT ONLY ALUMINUM GLASS, OR STEEL PRODUCTS PRODUCED IN THE UNITED STATES</p> | | | | | | |

SEE REVERSE SIDE FOR TERMS AND CONDITIONS

| | | |
|-------------------------------|-----------------------------------|------------------------|
| SIGNATURE <i>Ron Price</i> | TELEPHONE | DATE <i>4-26-10</i> |
| TITLE <i>President</i> | ADDRESS CHANGES TO BE NOTED ABOVE | |

WHEN RESPONDING TO RFQ, INSERT NAME AND ADDRESS IN SPACE ABOVE LABELED 'VENDOR'



State of West Virginia
 Department of Administration
 Purchasing Division
 2019 Washington Street East
 Post Office Box 50130
 Charleston, WV 25305-0130

**Request for
 Quotation**

RFQ NUMBER
AGR1019

PAGE
5

ADDRESS CORRESPONDENCE TO ATTENTION OF
**RON PRICE
 304-558-0492**

RFQ COPY
 TYPE NAME/ADDRESS HERE

VENDOR

SHIP TO

DEPARTMENT OF AGRICULTURE
 BUILDINGS & GROUNDS DIVISION
 BUILDING 17
 4720 BRENDA LANE
 CHARLESTON, WV
 25312 558-2222

| DATE PRINTED | TERMS OF SALE | SHIP VIA | FOB | FREIGHT TERMS |
|------------------------------|---------------|--------------------------|-----|---------------|
| 04/01/2010 | | | | |
| BID OPENING DATE: 05/04/2010 | | BID OPENING TIME 01:30PM | | |

| LINE | QUANTITY | UOP | CAT NO | ITEM NUMBER | UNIT PRICE | AMOUNT |
|--|----------|-----|--------|-------------|------------|--------|
| <p>IN ADDITION, ITEMS OF MACHINERY OR EQUIPMENT PURCHASED FOR USE AT THE SITE OF PUBLIC WORKS SHALL BE MADE OF DOMESTIC ALUMINUM, GLASS OR STEEL, UNLESS THE COST OF THE PRODUCT IS LESS THAN \$50,000 OR LESS THAN 10,000 POUNDS OF STEEL ARE USED IN PUBLIC WORKS PROJECTS.</p> <p>FOREIGN MADE ALUMINUM, GLASS OR STEEL PRODUCTS MAY BE ACCEPTED ONLY IF THE COST OF DOMESTIC PRODUCTS IS FOUND TO BE UNREASONABLE. SUCH COST IS UNREASONABLE IF IT IS 20% OR MORE HIGHER THAN THE BID PRICE FOR FOREIGN MADE PRODUCTS. IF THE DOMESTIC ALUMINUM, GLASS OR STEEL PRODUCTS TO BE SUPPLIED OR PRODUCED IN A "SUBSTANTIAL LABOR SURPLUS AREA", AS DEFINED BY THE UNITED STATES DEPARTMENT OF LABOR, FOREIGN PRODUCTS MAY BE SUPPLIED ONLY IF DOMESTIC PRODUCTS ARE 30% OR MORE HIGHER IN PRICE THAN THE FOREIGN MADE PRODUCTS.</p> <p>IF, PRIOR TO THE AWARD OF A CONTRACT UNDER THE ABOVE PROVISIONS, THE SPENDING OFFICER OF THE SPENDING UNIT DETERMINES THAT THERE EXISTS A BID FOR LIKE FOREIGN ALUMINUM, GLASS OR STEEL THAT IS REASONABLE AND LOWER THAN THE LOWEST BID DOMESTIC PRODUCTS, THE SPENDING OFFICE MAY REQUEST, IN WRITING, A REEVALUATION AND REDUCTION IN THE LOWEST BID FOR SUCH DOMESTIC PRODUCTS ALL VENDORS MUST INDICATE IN THEIR BID IF THEY ARE SUPPLYING FOREIGN ALUMINUM, GLASS OR STEEL.</p> <p>REV. 3/88</p> <p>EXHIBIT 9</p> <p>NOTICE FOR ISSUANCE & ACKNOWLEDGEMENT OF CONSTRUCTION PROJECT ADDENDA</p> <p>THE ARCHITECT/ENGINEER AND/OR AGENCY SHALL BE REQUIRED</p> | | | | | | |

SEE REVERSE SIDE FOR TERMS AND CONDITIONS

SIGNATURE: *[Signature]* TELEPHONE: DATE: 4-26-10

TITLE: Pres. FERN ADDRESS CHANGES TO BE NOTED ABOVE

WHEN RESPONDING TO RFQ, INSERT NAME AND ADDRESS IN SPACE ABOVE LABELED 'VENDOR'



State of West Virginia
 Department of Administration
 Purchasing Division
 2019 Washington Street East
 Post Office Box 50130
 Charleston, WV 25305-0130

Request for Quotation

RFQ NUMBER
AGR1019

PAGE
6

ADDRESS CORRESPONDENCE TO ATTENTION OF
RON PRICE
304-558-0492

RFQ COPY
 TYPE NAME/ADDRESS HERE

DEPARTMENT OF AGRICULTURE
 BUILDINGS & GROUNDS DIVISION
 BUILDING 17
 4720 BRENDA LANE
 CHARLESTON, WV
 25312 558-2222

| DATE PRINTED | TERMS OF SALE | SHIP VIA | F.O.B. | FREIGHT TERMS |
|--------------|---------------|----------|--------|---------------|
| 04/01/2010 | | | | |

BID OPENING DATE: **05/04/2010** BID OPENING TIME **01:30PM**

| LINE | QUANTITY | UOP | CAT. NO. | ITEM NUMBER | UNIT PRICE | AMOUNT |
|--|----------|-----|----------|-------------|------------|--------|
| | | | | | | |
| <p>TO ABIDE BY THE FOLLOWING SCHEDULE IN ISSUING CONSTRUCTION PROJECT ADDENDA FOR STATE AGENCIES:</p> <p>(1) THE ARCHITECT/ENGINEER SHALL PREPARE THE ADDENDUM AND A LIST OF ALL PARTIES THAT HAVE PROCURED DRAWINGS AND SPECIFICATIONS FOR THE PROJECT. THE ADDENDUM AND LIST SHALL BE FORWARDED TO THE BUYER IN THE STATE PURCHASING DIVISION. THE ARCHITECT/ENGINEER SHALL ALSO SEND A COPY OF THE ADDENDUM TO THE STATE AGENCY FOR WHICH THE CONTRACT IS ISSUED.</p> <p>(2) THE BUYER SHALL SEND THE ADDENDUM TO ALL INTERESTED PARTIES AND, IF NECESSARY, EXTEND THE BID OPENING DATE. ANY ADDENDUM SHOULD BE RECEIVED BY THE BUYER WITHIN FOURTEEN (14) DAYS PRIOR TO THE BID OPENING DATE.</p> <p>(3) ALL ADDENDA SHOULD BE FORMALLY ACKNOWLEDGED BY ALL BIDDERS AND SUBMITTED TO THE STATE PURCHASING DIVISION. THE SAME RULES AND REGULATIONS THAT APPLY TO THE ORIGINAL BIDDING DOCUMENT SHALL ALSO APPLY TO AN ADDENDUM DOCUMENT. THE ONLY EXCEPTION MAY BE FOR AN ADDENDUM THAT IS ISSUED FOR THE SOLE PURPOSE OF CHANGING A BID OPENING TIME AND/OR DATE.</p> <p>REV. 11/96</p> <p>EXHIBIT 10</p> <p>ADDENDUM ACKNOWLEDGEMENT</p> <p>I HEREBY ACKNOWLEDGE RECEIPT OF THE FOLLOWING CHECKED ADDENDUM(S) AND HAVE MADE THE NECESSARY REVISIONS TO MY PROPOSAL, PLANS AND/OR SPECIFICATION, ETC.</p> | | | | | | |

SEE REVERSE SIDE FOR TERMS AND CONDITIONS

| | | |
|-------------------------------|-----------|-----------------------------------|
| SIGNATURE <i>Ron Price</i> | TELEPHONE | DATE 4-26-10 |
| TITLE <i>Pres</i> | FIRM | ADDRESS CHANGES TO BE NOTED ABOVE |

WHEN RESPONDING TO RFQ, INSERT NAME AND ADDRESS IN SPACE ABOVE LABELED 'VENDOR'



State of West Virginia
 Department of Administration
 Purchasing Division
 2019 Washington Street East
 Post Office Box 50130
 Charleston, WV 25305-0130

Request for Quotation

RFQ NUMBER
AGR1019

PAGE
7

ADDRESS CORRESPONDENCE TO ATTENTION OF
RON PRICE
304-558-0492

RFQ COPY
 TYPE NAME/ADDRESS HERE

DEPARTMENT OF AGRICULTURE
 BUILDINGS & GROUNDS DIVISION
 BUILDING 17
 4720 BRENDA LANE
 CHARLESTON, WV
 25312 558-2222

| | | | | |
|-------------------------------------|---------------|---------------------------------|-----|---------------|
| DATE PRINTED 04/01/2010 | TERMS OF SALE | SHIP VIA | FOB | FREIGHT TERMS |
| BID OPENING DATE: 05/04/2010 | | BID OPENING TIME 01:30PM | | |

| LINE | QUANTITY | UOP | CAT NO | ITEM NUMBER | UNIT PRICE | AMOUNT |
|--|----------|-----|------------|-------------|------------|--------|
| ADDENDUM NOS.: | | | | | | |
| NO. 1 | | | <i>RKC</i> | | | |
| NO. 2 | | | <i>RKC</i> | | | |
| NO. 3 | | | | | | |
| NO. 4 | | | | | | |
| NO. 5 | | | | | | |
| <p>I UNDERSTAND THAT FAILURE TO CONFIRM THE RECEIPT OF THE ADDENDUM(S) MAY BE CAUSE FOR REJECTION OF THE BIDS.</p> <p>VENDOR MUST CLEARLY UNDERSTAND THAT ANY VERBAL REPRESENTATION MADE OR ASSUMED TO BE MADE DURING ANY ORAL DISCUSSION HELD BETWEEN VENDOR'S REPRESENTATIVES AND ANY STATE PERSONNEL IS NOT BINDING. ONLY THE INFORMATION ISSUED IN WRITING AND ADDED TO THE SPECIFICATIONS BY AN OFFICIAL ADDENDUM IS BINDING.</p> <p>.....<i>Robin K. Cumber</i>.....SIGNATURE <i>PLEASANT AIR</i>.....COMPANY <i>4-26-10</i>.....DATE</p> <p>REV. 11/96</p> <p>CONTRACTORS LICENSE</p> <p>WEST VIRGINIA STATE CODE 21-11-2 REQUIRES THAT ALL</p> | | | | | | |

SEE REVERSE SIDE FOR TERMS AND CONDITIONS

| | | |
|-------------------------------------|-----------|-----------------------------------|
| SIGNATURE <i>Robin K. Cumber</i> | TELEPHONE | DATE <i>4-26-10</i> |
| TITLE <i>Pres</i> | FEIN | ADDRESS CHANGES TO BE NOTED ABOVE |

WHEN RESPONDING TO RFQ, INSERT NAME AND ADDRESS IN SPACE ABOVE LABELED 'VENDOR'



State of West Virginia
 Department of Administration
 Purchasing Division
 2019 Washington Street East
 Post Office Box 50130
 Charleston, WV 25305-0130

Request for Quotation

| |
|------------|
| RFQ NUMBER |
| AGR1019 |

| |
|------|
| PAGE |
| 8 |

| |
|--|
| ADDRESS CORRESPONDENCE TO ATTENTION OF |
| RON PRICE |
| 304-558-0492 |

RFQ COPY
 TYPE NAME/ADDRESS HERE

POSTING

SHIP TO

DEPARTMENT OF AGRICULTURE
 BUILDINGS & GROUNDS DIVISION
 BUILDING 17
 4720 BRENDA LANE
 CHARLESTON, WV
 25312 558-2222

| | | | | |
|--------------|---------------|----------|-----|---------------|
| DATE PRINTED | TERMS OF SALE | SHIP VIA | FOB | FREIGHT TERMS |
| 04/01/2010 | | | | |

BID OPENING DATE: **05/04/2010** BID OPENING TIME **01:30PM**

| LINE | QUANTITY | UOP | CAT NO | ITEM NUMBER | UNIT PRICE | AMOUNT |
|--|----------|-----|--------|-------------|------------|--------|
| <p>PERSONS DESIRING TO PERFORM CONTRACTING WORK IN THIS STATE MUST BE LICENSED. THE WEST VIRGINIA CONTRACTORS LICENSING BOARD IS EMPOWERED TO ISSUE THE CONTRACTORS LICENSE. APPLICATIONS FOR A CONTRACTORS LICENSE MAY BE MADE BY CONTACTING THE WEST VIRGINIA DIVISION OF LABOR CAPITOL COMPLEX, BUILDING 3, ROOM 319, CHARLESTON, WV 25305. TELEPHONE: (304) 558-7890.</p> <p>WEST VIRGINIA STATE CODE 21-11-11 REQUIRES ANY PROSPECTIVE BIDDER TO INCLUDE THE CONTRACTORS LICENSE NUMBER ON THEIR BID.</p> <p>BIDDER TO COMPLETE:</p> <p>CONTRACTORS NAME: <i>P. PLEASANT. AIR HEATING & COOLING, INC</i></p> <p>CONTRACTORS LICENSE NO.: <i>WV.00.9708.....</i></p> <p>THE SUCCESSFUL BIDDER WILL BE REQUIRED TO FURNISH A COPY OF THEIR CONTRACTORS LICENSE PRIOR TO ISSUANCE OF A PURCHASE ORDER/CONTRACT</p> <p>APPLICABLE LAW</p> <p>THE WEST VIRGINIA STATE CODE, PURCHASING DIVISION RULES AND REGULATIONS, AND THE INFORMATION PROVIDED IN THE "REQUEST FOR QUOTATION" ISSUED BY THE PURCHASING DIVISION IS THE SOLE AUTHORITY GOVERNING THIS PROCUREMENT.</p> <p>ANY INFORMATION PROVIDED IN SPECIFICATION MANUALS, OR ANY OTHER SOURCE, VERBAL OR WRITTEN, WHICH CONTRADICTS OR ALTERS THE INFORMATION PROVIDED FROM THE SOURCES AS DESCRIBED IN THE ABOVE PARAGRAPH IS VOID AND OF NO EFFECT.</p> | | | | | | |

SEE REVERSE SIDE FOR TERMS AND CONDITIONS

| | | |
|--------------------------------------|-----------------------------------|------------------------|
| SIGNATURE <i>Robert K. Gubler</i> | TELEPHONE | DATE <i>4-26-10</i> |
| TITLE <i>Pres</i> | ADDRESS CHANGES TO BE NOTED ABOVE | |

WHEN RESPONDING TO RFQ, INSERT NAME AND ADDRESS IN SPACE ABOVE LABELED 'VENDOR'



State of West Virginia
 Department of Administration
 Purchasing Division
 2019 Washington Street East
 Post Office Box 50130
 Charleston, WV 25305-0130

Request for Quotation

RFQ NUMBER
AGR1019

PAGE
9

ADDRESS CORRESPONDENCE TO ATTENTION OF
RON PRICE
304-558-0492

RFQ COPY
 TYPE NAME/ADDRESS HERE

DEPARTMENT OF AGRICULTURE
 BUILDINGS & GROUNDS DIVISION
 BUILDING 17
 4720 BRENDA LANE
 CHARLESTON, WV
 25312 558-2222

| DATE PRINTED | TERMS OF SALE | SHIP VIA | FOB | FREIGHT TERMS |
|--------------|---------------|----------|-----|---------------|
| 04/01/2010 | | | | |

BID OPENING DATE: **05/04/2010** BID OPENING TIME **01:30PM**

| LINE | QUANTITY | UOP | CAT NO | ITEM NUMBER | UNIT PRICE | AMOUNT |
|--|----------|-----|--------|-------------|------------|--------|
| <p>BANKRUPTCY: IN THE EVENT THE VENDOR/CONTRACTOR FILES FOR BANKRUPTCY PROTECTION, THE STATE MAY DEEM THE CONTRACT NULL AND VOID, AND TERMINATE SUCH CONTRACT WITHOUT FURTHER ORDER.</p> <p>REV. 5/2009</p> <p style="text-align: center;">NOTICE</p> <p>A SIGNED BID MUST BE SUBMITTED TO:</p> <p style="text-align: center;">DEPARTMENT OF ADMINISTRATION PURCHASING DIVISION BUILDING 15 2019 WASHINGTON STREET, EAST CHARLESTON, WV 25305-0130</p> <p>THE BID SHOULD CONTAIN THIS INFORMATION ON THE FACE OF THE ENVELOPE OR THE BID MAY NOT BE CONSIDERED:</p> <p>SEALED BID</p> <p>BUYER: RP-41</p> <p>REQ. NO.: AGR1019</p> <p>BID OPENING DATE: MAY 4, 2010</p> <p>BID OPENING TIME: 1:30 PM</p> <p>PLEASE PROVIDE A FAX NUMBER IN CASE IT IS NECESSARY TO CONTACT YOU REGARDING YOUR BID:</p> <p style="text-align: center;">----- 304 485-7601 -----</p> | | | | | | |

SEE REVERSE SIDE FOR TERMS AND CONDITIONS

| | | |
|--------------------------------------|-----------|-----------------------------------|
| SIGNATURE <i>Robert K. Cauden</i> | TELEPHONE | DATE 4-26-10 |
| TITLE <i>Pres.</i> | FEIN | ADDRESS CHANGES TO BE NOTED ABOVE |

WHEN RESPONDING TO RFQ, INSERT NAME AND ADDRESS IN SPACE ABOVE LABELED 'VENDOR'



State of West Virginia
 Department of Administration
 Purchasing Division
 2019 Washington Street East
 Post Office Box 50130
 Charleston, WV 25305-0130

Request for Quotation

RFQ NUMBER
AGR1019

PAGE
10

ADDRESS CORRESPONDENCE TO ATTENTION OF
RON PRICE
304-558-0492

SUPPLIER

RFQ COPY
 TYPE NAME/ADDRESS HERE

VENDOR

DEPARTMENT OF AGRICULTURE
 BUILDINGS & GROUNDS DIVISION
 BUILDING 17
 4720 BRENDA LANE
 CHARLESTON, WV
 25312 558-2222

| DATE PRINTED | TERMS OF SALE | SHIP VIA | FOB | FREIGHT TERMS |
|--------------|---------------|----------|-----|---------------|
| 04/01/2010 | | | | |

BID OPENING DATE: **05/04/2010** BID OPENING TIME **01:30PM**

| LINE | QUANTITY | UOP | CAT NO | ITEM NUMBER | UNIT PRICE | AMOUNT |
|---|----------|-----|--------|-------------|------------|------------------------------|
| PLEASE PRINT OR TYPE NAME OF PERSON TO CONTACT CONCERNING THIS QUOTE: <u>ROBIN K. CRUMBAKER</u> | | | | | | |
| ***** THIS IS THE END OF RFQ AGR1019 ***** TOTAL: | | | | | | \$ <u>68530⁰⁰</u> |

SEE REVERSE SIDE FOR TERMS AND CONDITIONS

| | | |
|--|---------------------------|-----------------------------------|
| SIGNATURE <i>Robin K. Crumbaker</i> | TELEPHONE 304-428-5799 | DATE 4-26-10 |
| TITLE Pres | FEIN 55-0699312 | ADDRESS CHANGES TO BE NOTED ABOVE |

WHEN RESPONDING TO RFQ, INSERT NAME AND ADDRESS IN SPACE ABOVE LABELED 'VENDOR'

West Virginia Department of Agriculture
 Administrative Services Division, Building & Grounds
 HVAC Replacement & Installation

BID FORM - Attachment # 16

Name of Bidder PLEASANT AIR

| Building Number | Building Description | Cost |
|----------------------------------|--|-------|
| Building 1 | 163 Gus R. Douglass Lane | 5648 |
| Building 7 | 281 Gus R. Douglass Lane | 6205 |
| Building 9 | 297 Gus R. Douglass Lane (Insect Museum) | 6526 |
| Building 9 | 297 Gus R. Douglass Lane (Plant Pathology Lab) | 6205 |
| Building 11 | 313 Gus R. Douglass Lane (Unit # 1) | 5648 |
| Building 11 | 313 Gus R. Douglass Lane (Unit # 7) | 3316 |
| Building 11 | 313 Gus R. Douglass Lane (Front Office Unit # 4) | 5648 |
| Building 11 Option A | 313 Gus R. Douglass Lane (Unit # 8 Replace all Equip) (Option A) | 5648 |
| Building 11 Option B | 313 Gus R. Douglass Lane (Unit # 8 Replace Cooling Equip) (Option B) | 3997 |
| Building 15 | 391 Gus R. Douglass Lane (Office) | 10526 |
| Building 15 | 391 Gus R. Douglass Lane (Print Shop) | 4986 |
| Building 17A | 419 Gus R. Douglass Lane | 6526 |
| Building 17B | 423 Gus R. Douglass Lane (Carpenter Shop) | 51049 |
| Total Including BLDG 11 Option A | | 62530 |
| Total Including BLDG 11 Option B | | 66879 |

Signature 

We, the undersigned, having examined the site and being familiar with the local conditions affecting the cost of the work and also being familiar with the general conditions to bidders, drawings, and specifications, hereby propose to furnish all materials, equipment, and labor to complete all work in a workmanlike manner, as described in the bidding documents.

This certifies I have received and reviewed these Special Provisions relating to the American Recovery and Reinvestment Act of 2009.

Robin K. Anderson
Signature

4-26-10
Date

PLEASANT AIR
Subawardee (Agency)

Pleasant Air Heating & Cooling, Inc.

5200 Emerson Ave
Parkersburg WV 26101
St. Marys WV 26101
WV LIC # WV009708

Phone 304-428-5799
Phone 304-684-2323
Fax 304-485-7601

We have bid to use Luxaire brand equipment on this project. The RFQ asks for submittals on the equipment if other than the York brand specified. We have enclosed those submittals. Both Luxaire and York are manufactured by Johnson Controls and are identical. The only difference in the model numbers being the first digit which designates one of the three brands that Johnson Controls markets the equipment under.

SUBMITTAL DATA SHEET

95.5% SINGLE STAGE GAS-FIRED RESIDENTIAL MULTI-POSITION GAS FURNACES MODELS: TM9X

JOB NAME: Gus Douglas Center LOCATION: Guthrie, WV

PURCHASER: WV Dept of Agr. ORDER NO:

ENGINEER:

SUBMITTED TO: FOR: REF: XX APPROVAL: CONSTRUCTION:

SUBMITTED BY: Pleasant Air DATE: 5-1-2010

UNIT DESIGNATION: Various SCHEDULE NO. MODEL NO.

DIMENSIONS - INCHES

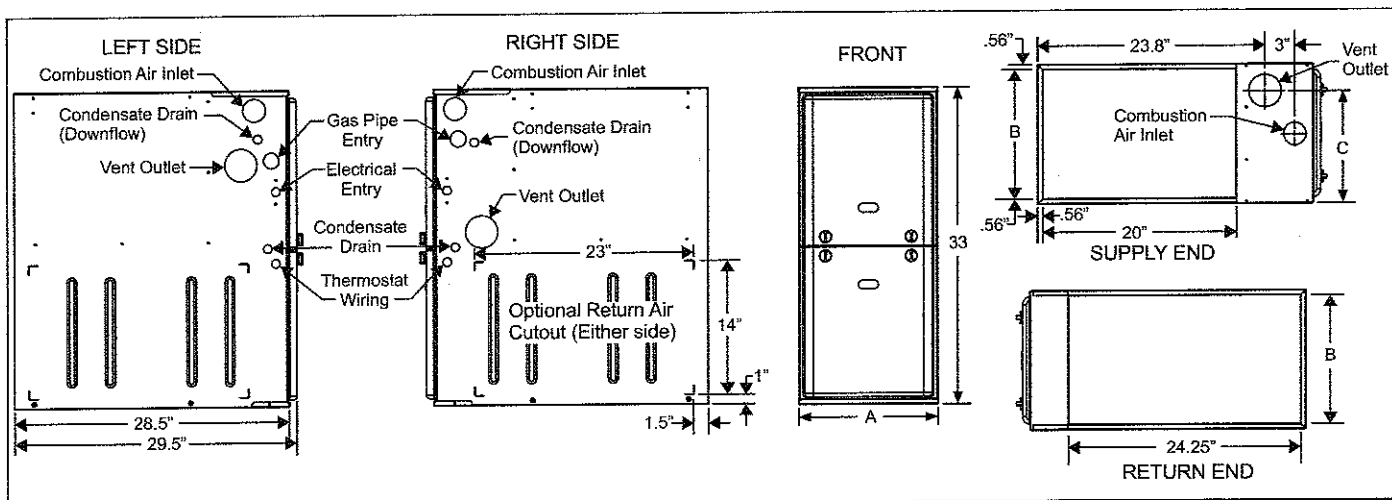

| BTUH (kW) Input | Nominal CFM | Cabinet Size | Cabinet Dimensions (Inches) | | | Approximate Operating Weights |
|--------------------|----------------|-----------------|--------------------------------|--------|--------|-------------------------------------|
| | | | A | B | C | Lbs |
| TM9X060B12MP11 | 1200 | B | 17 1/2 | 16 3/8 | 13 1/4 | 122 |
| TM9X080B12MP11 | 1200 | B | 17 1/2 | 16 3/8 | 14 3/4 | 126 |
| TM9X080C16MP11 | 1600 | C | 21 | 19 7/8 | 16 1/2 | 136 |
| TM9X100C16MP11 | 1600 | C | 21 | 19 7/8 | 18 1/4 | 142 |
| TM9X100C20MP11 | 2000 | C | 21 | 19 7/8 | 18 1/4 | 145 |
| TM9X120D20MP11 | 2000 | D | 24 1/2 | 23 3/8 | 21 3/4 | 156 |

Due to continuous product improvements, specifications are subject to change without notice. Installation and conversions of these furnaces must be made by qualified distributor, dealer, or contractor personnel.

PRODUCT DATA

Heating Performance

Input Capacity _____ MBH

Output Capacity _____ MBH

Air Temp. Rise _____ °F

Supply Air Blower Performance

Total Supply Air _____ CFM

Total External Static Pressure _____ IWG

Blower Speed (circle) ___ HI MH ML L

Motor Rating _____ HP

Electrical Data

Power Supply _____ / /

Total Unit Ampacity _____ AMPS

Minimum Wire Size _____ AWG

Maximum Overcurrent Device

Fuses Circuit

Breaker _____ AMPS

Unit Weight

Total Unit Weight _____ LBS



FEATURES

- Easily applied in upflow, horizontal left or right, or downflow installation with minimal conversion necessary.
- Compact, easy to install, ideal height 33" tall cabinet.
- Blower-off delay for cooling SEER improvement.
- Easy access to controls to connect power/control wiring.
- Built-in, high level self diagnostics with fault code displays standard on integrated control module for reliable operation.
- Low unit amp requirement for easy replacement application.
- All models are convertible to use propane (LP) gas.
- Electronic Hot Surface Ignition saves fuel cost with increased dependability and reliability.
- 100% shut off main gas valve for extra safety.
- 5 speed, direct drive X13 style high efficiency DC motor.
- 24V, 40 VA control transformer and blower relay supplied for add-on cooling.
- Hi-tech tubular aluminized steel primary heat exchanger.
- Secondary heat exchanger made of corrosion resistant stainless steel materials.
- Timed on, adjustable off blower capability for maximum comfort.
- Blower door safety switch.
- Solid removable bottom panel allows easy conversion.
- Airflow leakage less than 1% of nominal airflow at ductblaster conditions.
- No knockouts to deal with, making installation easier.
- Movable duct connector flanges for application flexibility.
- Quiet inducer operation.
- Inducer rotates for easy conversion of venting options.
- Fully supported blower assembly for easy access and removal of blower.
- External air filters used for maximum flexibility in meeting customers IAQ needs.
- Protection included from air intake, exhaust vent, or condensate blockage.
- Patent pending self priming internal condensate trap design for easy installation.
- Venting applications - may be installed as a either 2-pipe (sealed combustion) or single-pipe vent (using indoor combustion air).
- No special vent termination required.
- 1/4 turn knobs provided for easy door removal.
- High-efficiency blower motor for lower electrical power usage and improved A/C SEER ratings.
- Insulated blower compartment for terminal and acoustic performance.

FIELD INSTALLED ACCESSORIES

PROPANE (LP) CONVERSION KIT -

S1-1NP0347 - All Models

This accessory conversion kit may be used to convert natural gas (N) units for propane (LP) operation.

CONCENTRIC VENT TERMINATION -

S1-1CT0302 (2") & S1-1CT0302-636 (2")

S1-1CT0303 (3") & S1-1CT0303-636 (3")

For use through rooftop, sidewall. Allows combustion air to enter and exhaust to exit through single common hole. Eliminates unsightly elbows for a cleaner installation.

SIDEWALL VENT TERMINATION KIT -

S1-1HT0901 (3")

S1-1HT0902 (2")

For use on sidewall, two-pipe installations only. Provide a more attractive termination for locations where the terminal is visible on the side of the home.

CONDENSATE NEUTRALIZER KIT - 1NK0301

Neutralizer cartridge has a 1/2" plastic tube fittings for installation in the drain line. Calcium carbonate refill media is also available from the Source 1 Parts (p/n 026-30228-000).

SIDE RETURN FILTER RACKS -

S1-1SR0200 - All Models

S1-1SR0402 - All Models

BOTTOM RETURN FILTER RACKS -

S1-1BR0517 or 1BR0617 - For 17-1/2" cabinets

S1-1BR0521 or 1BR0621 - For 21" cabinets

S1-1BR0524 or 1BR0624 - For 24-1/2" cabinets

1BR05xx series are galvanized steel filter racks. 1BR06xx are pre-painted steel filter racks to match the appearance of the furnace cabinet.

COMBUSTIBLE FLOOR BASE KIT -

For installation of these furnaces in downflow applications directly onto combustible flooring material, These kits are required to prevent potential overheating situations.

S1-1CB0517 - For 17-1/2" cabinets

S1-1CB0521 - For 21" cabinets

S1-1CB0524 - For 24-1/2" cabinets

EAC TRANSITION KITS -

For installation of EAC accessories with these furnaces to provide easy transition of return airflow through the EAC to get the proper sealing and reduced airflow leakage.

S1-1TK1001 - For all models using side return

S1-1TK1017 - For 17-1/2" cabinets using bottom return

S1-1TK1021 - For 21" cabinets using bottom return

S1-1TK1024 - For 24-1/2" cabinets using bottom return

HIGH ALTITUDE PRESSURE SWITCHES -

For installation where the altitude is less than 5,000 feet it is not required that the pressure switch be changed. For altitudes above 5,000 feet, see kits below.

S1-1PS3306 - 080

S1-1PS3307 - 060

S1-1PS3302 - 100, 120

SUBMITTAL DATA SHEET

**FULL-CASED MULTI-POSITION ADD-ON COILS
FOR USE WITH SPLIT-SYSTEM COOLING & HEAT PUMPS**
MODELS: MC

JOB NAME: Gus Douglas Center LOCATION: Guthrie, WV
PURCHASER: WV Dept. of Agr. ORDER NO:
ENGINEER:
SUBMITTED TO: FOR: REF: XX APPROVAL: CONSTRUCTION:
SUBMITTED BY: Pleasant Air DATE:
UNIT DESIGNATION: Various SCHEDULE NO. MODEL NO.

PRODUCT DATA

Cooling Performance

Total Capacity* VARIOUS MBH
Sensible Capacity* _____ MBH
Temperature of Air Entering
Indoor Coil _____ °F (DB/WB)

Supply Air Blower Performance

Total Supply Air VARIOUS CFM
Total Resistance External To Unit _____ IWG
Blower Speed Tap _____ RPM
Motor Rating _____ HP

Electrical Data

Power Supply N/A
Total Unit Ampacity _____ AMPS
Minimum Wire Size _____ AWG
(Copper conductors)
Maximum Overcurrent Device _____ AMPS
 Fuses (Dual Element)
 Circuit Breaker (HACR)

Unit Weight

Total Operating Weight _____ LBS
(Including field-installed accessories)
* Shown in Outdoor Unit Technical Guide

CLEARANCES

| | |
|-------|-----|
| Front | 24" |
| Rear | 0" |
| Sides | 0" |

Recommended service clearance.

FEATURES

MC COILS

- Rified copper tubes and aluminum fins
- Sweat connect refrigerant connections
- MC - upflow, downflow and horizontal applications
- 3/4" insulation standard
- Available with or without factory installed R-22 TXV

MATCHED INDOOR UNIT

- Model Number (# VARIOUS)
 Submittal Part Number (# _____)

MATCHED OUTDOOR UNIT

- Model Number (# VARIOUS)
 Submittal Part Number (# _____)

FIELD INSTALLED ACCESSORIES

- Electric Heaters (# NONE)
 Capacity (@ _____ Volts) _____ MBH
 Power Input Requirement (Less Blower Motor) _____ KW
 Filter Rack (# _____)
 Combustible Floor Base (# _____)
 Interconnecting Lines. . . . Length _____ Ft
 Thermal Expansion Valve Kit (# _____)



TABULAR DATA SHEET

Outdoor Split System Air Conditioner 2 Thru 5 Tons

MODELS: TCJF24* THRU 60
14.5 SEER – R-410A, 1 PHASE

Physical and Electrical Data

| MODEL | | TCJF24S41S3 | TCJF30S41S3 | 3 TON TCJF36S41S3 | TCJF42S41S3 | 4 TON TCJF48S41S3 | 5 TON TCJF60S41S3 |
|---|---------------------|---------------------------|-------------|----------------------|-------------|----------------------|----------------------|
| Unit Supply Voltage | | 208-230V, 1 ϕ , 60Hz | | | | | |
| Normal Voltage Range ¹ | | 187 to 252 | | | | | |
| Minimum Circuit Ampacity | | 16.8 | 18.4 | 19.1 | 23.9 | 27.9 | 35.9 |
| Max. Overcurrent Device Amps ² | | 25 | 30 | 30 | 40 | 45 | 60 |
| Min. Overcurrent Device Amps ³ | | 20 | 20 | 20 | 25 | 30 | 40 |
| Compressor Type | | Scroll | Scroll | Scroll | Scroll | Scroll | Scroll |
| Compressor Amps | Rated Load | 12.8 | 14.1 | 14.1 | 17.9 | 21.1 | 27.5 |
| | Locked Rotor | 58 | 73 | 77 | 112 | 115 | 135 |
| Crankcase Heater | | No | No | No | No | No | No |
| Fan Motor Amps | Rated Load | .8 | .8 | 1.5 | 1.5 | 1.5 | 1.5 |
| | Fan Diameter inches | 22 | 22 | 22 | 24 | 24 | 24 |
| Fan Motor | Rated HP | 1/8 | 1/8 | 1/4 | 1/4 | 1/4 | 1/4 |
| | Nominal RPM | 1075 | 1075 | 850 | 850 | 850 | 850 |
| | Nominal CFM | 2750 | 2800 | 3200 | 3600 | 3600 | 3700 |
| Coil | Face Area Sq. Ft. | 13.1 | 17.4 | 17.4 | 20.0 | 21.4 | 24.0 |
| | Rows Deep | 1 | 1 | 1 | 1 | 1 | 1 |
| | Fin / inches | 23 | 23 | 23 | 23 | 23 | 23 |
| Liquid Line Set OD (Field Installed) | | 3/8 | 3/8 | 3/8 | 3/8 | 3/8 | 3/8 |
| Vapor Line Set OD (Field Installed) | | 3/4 | 3/4 | 3/4 | 7/8 | 7/8 | 1 1/8 |
| Unit Charge (Lbs. - Oz.) ⁴ | | 3 - 2 | 3 - 7 | 3 - 10 | 4 - 4 | 4 - 9 | 5 - 9 |
| Charge Per Foot, Oz. | | 0.62 | 0.62 | 0.62 | 0.67 | 0.67 | 0.75 |
| Operating Weight Lbs. | | 128 | 130 | 145 | 172 | 180 | 199 |

1. Rated in accordance with ARI Standard 110, utilization range . . .
2. Dual element fuses or HACR circuit breaker. Maximum allowable overcurrent protection.
3. Dual element fuses or HACR circuit breaker. Minimum recommended overcurrent protection.
4. The Unit Charge is correct for the outdoor unit, smallest matched evaporator coil and 15 feet of refrigerant tubing. For tubing lengths other than 15 feet, add or subtract the amount of refrigerant, using the difference in length multiplied by the per foot value.

All dimensions are in inches. They are subject to change without notice. Certified dimensions will be provided upon request.

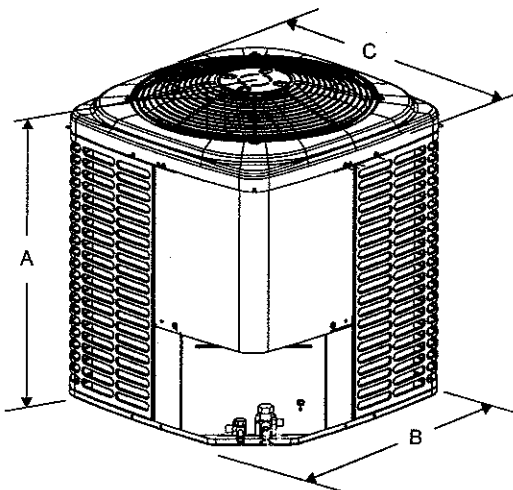

| Unit Model | Dimensions (Inches) | | | Refrigerant Connection Service Valve Size | |
|------------|---------------------|------|------|---|-------|
| | A ¹ | B | C | Liquid | Vapor |
| 24 | 28 | 29 | 29 | 3/8" | 3/4" |
| 30 | 36 | 29 | 29 | | |
| 36 | 36 | 29 | 29 | | |
| 42 | 34 | 33.6 | 33.6 | | 7/8" |
| 48 | 36 | 33.6 | 33.6 | | |
| 60 | 40 | 33.6 | 33.6 | 7/8" ² | |

1. Including Fan Guard.
2. Adapter fitting required for 1-1/8" line set.

System Charge for Various Matched Systems

| Outdoor Unit | TCJF24S41S3 | TCJF30S41S3 | TCJF36S41S3 | TCJF42S41S3 | TCJF48S41S3 | TCJF60S41S3 |
|--------------------------------------|-----------------------|-------------|-------------|-------------|-------------|-------------|
| Required Orifice or TXV ¹ | 1TVM4F1 | 1TVM4G1 | 1TVM4G1 | 1TVM4G1 | 1TVM4J1 | 1TVM4J1 |
| Factory Charge, lbs-oz | 3 - 2 | 3 - 7 | 3 - 10 | 4 - 4 | 4 - 9 | 5 - 9 |
| Indoor Coil ^{2,3,4} | Additional Charge, oz | | | | | |
| FC/MC/PC24 | 10 | - | - | - | - | - |
| FC/MC/PC30 | 10 | 2 | - | - | - | - |
| FC/MC/PC35 | 16 | 10 | - | - | - | - |
| FC/MC/PC36 | 10 | 4 | 5 | - | - | - |
| FC/MC/PC37 | 24 | 19 | 15 | - | - | - |
| FC/MC/PC43 | 24 | 19 | 15 | 5 | - | - |
| FC/MC/PC48 | 40 | 32 | 27 | 17 | 16 | - |
| FC/MC/PC60 | - | - | - | 17 | 16 | 0 |
| FC/MC62 | - | - | - | 25 | 26 | 18 |
| FC64 | - | - | - | 30 | 33 | 25 |
| UC24 | 8 | - | - | - | - | - |
| UC60 | - | - | 12 | - | - | - |
| HC30 | 10 | - | - | - | - | - |
| HC36 | 16 | 11 | 8 | - | - | - |
| HC42 | 25 | 19 | 15 | 6 | - | - |
| HC60 | - | - | - | 0 | 0 | 0 |
| HD24 | 16 | - | - | - | - | - |
| HD36 | 18 | - | - | - | - | - |
| HD48 | 51 | 42 | 36 | 24 | 25 | - |
| HD60 | - | - | - | - | 24 | 24 |
| AHP30 | 16 | - | - | - | - | - |
| AHP36 | - | 19 | 15 | - | - | - |
| AHX30 | 16 | 11 | - | - | - | - |
| AHX36 | - | 11 | 15 | - | - | - |
| AHX42 | - | 31 | 27 | 17 | - | - |
| AHX48 | - | 31 | 27 | 17 | 16 | - |
| AHX60 | - | - | 33 | 22 | 23 | 18 |
| AHP/SHP60 | - | - | - | - | 1 | - |
| AV*24 | 3 | - | - | - | - | - |
| AV*36 | 25 | 19 | 15 | - | - | - |
| AV/SV*48 | - | - | 9 | 0 | 1 | - |
| AV/SV*60 | - | - | - | 0 | 1 | 0 |
| F4FP030 | 3 | - | - | - | - | - |
| F4FP036 | - | - | 5 | - | - | - |
| F4FP040 | - | - | 8 | - | - | - |
| F4FP042 | - | - | 8 | - | - | - |
| F4FP045 | - | - | 9 | - | - | - |
| F5FP048 | - | - | 20 | 10 | 11 | - |
| F5FP060 | - | - | 20 | 10 | 11 | - |
| F4FV060 | - | - | 9 | 10 | 1 | - |
| F6FP030 | 17 | 11 | - | - | - | - |
| F6FP036 | - | 11 | 8 | - | - | - |
| F6FP042 | - | 23 | 19 | 17 | - | - |
| F6FP048 | - | 23 | 19 | 17 | 16 | - |
| F6FP060 | - | - | 33 | 23 | 23 | 18 |

FOOTNOTES:

1. Systems matched with furnace or air handlers not equipped with blower-off delays may require blower Time Delay Kit 2FD06700224.
2. PC coils cannot be used in downflow or horizontal applications. FC coils cannot be used in horizontal applications.
3. A TXV kit must be used with these coils to obtain system performance. Note: If a TXV is factory installed on the coil, it must be replaced with the listed TXV.
4. Refer to Technical Guide for actual system performance and matches.

PROCEDURES:

1. Unit factory charge listed on the unit nameplate includes refrigerant for the condenser, the smallest evaporator and 15 feet of interconnecting line tubing.
2. Verify the TXV or orifice and additional charge required for specific evaporator coil in the system using the above table.
3. Add additional charge for the amount of interconnecting line tubing greater than 15 feet at the rate specified in Physical and Electrical Data Table.
4. For TXV match charge weight needs to be weighed in for specific coil match and lineset length.
5. Permanently mark the unit nameplate with the total system charge. Total System Charge = Base Charge (as shipped) + adder for evaporator + adder for line set.



THE PAGE OF THIS DOCUMENT HAS A COLORED BACKGROUND-NOT A WHITE BACKGROUND

BID BOND AGR 1019
REMITTEE
JOYCE HAILEY
BANK ASSOCIATE
BRANCH NAME 304.424.6300



BRANCH TELEPHONE # @ your service

PARKERSBURG, WV 26101

Member FDIC

PAY

TO THE ORDER OF

STATE OF WV*

DATE

MAY 4, 2010

69-89
518

705891

3426 AND 5

3,426.50

Purchaser Notification: If the amount of this check is lost, stolen, or destroyed, a notarized affidavit and 90-day waiting period will be required prior to replacement or refund.

OFFICIAL BANK CHECK

Joyce Hailey

AUTHORIZED SIGNATURE



State of West Virginia
DRUG FREE WORKPLACE CONFORMANCE AFFIDAVIT
West Virginia Code §21-1D-5

STATE OF WEST VIRGINIA

COUNTY OF WOOD, TO-WIT:

I, ROBIN K. CRUMBAKER, after being first duly sworn, depose and state as follows:

- 1. I am an employee of PLEASANT AIR; and,
(Company Name)
- 2. I do hereby attest that PLEASANT AIR
(Company Name)

maintains a valid written drug free workplace policy and that such policy is in compliance with **West Virginia Code §21-1D-5**.

The above statements are sworn to under the penalty of perjury.

PLEASANT AIR
(Company Name)

By: Robin K. Crumbaker
ROBIN CRUMBAKER

Title: PRES

Date: 4-21-10

Taken, subscribed and sworn to before me this 21 day of April, 2010.

By Commission expires April 29, 2018

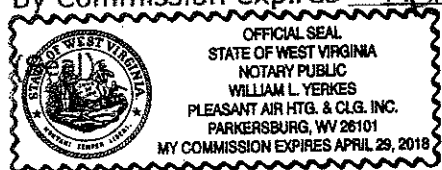

William L. Yerkes
(Notary Public)

THIS AFFIDAVIT MUST BE SUBMITTED WITH THE BID IN ORDER TO COMPLY WITH WV CODE PROVISIONS. FAILURE TO INCLUDE THE AFFIDAVIT WITH THE BID SHALL RESULT IN DISQUALIFICATION OF THE BID.

Recovery Act Requirements and Verification Form

Project Name: Project 2: HVAC Date: 4-26-10

Subcontractor Name: PLEASANT AIR

This project is funded in whole or in part by the American Recovery and Reinvestment Act of 2009 ("Recovery Act"). The following requirements, if checked apply to this project. By signing and returning this form you are verifying that you understand and accept these requirements.

"Buy American" Requirements

For definitions of "construction material," "manufactured," "trade agreement countries," and "least-developed" countries see Attachment 2.

- All construction material must be manufactured in the United States.
- All construction material must be manufactured in the United States or a trade agreement country.
- All construction material must be manufactured in the United States or a trade agreement country, or a least-developed country.

List below any products that do not meet the above requirement. Attach separate sheet if necessary:

Prevailing Wage Requirement

- All laborers and mechanics must be paid prevailing wage in accordance with the Davis-Bacon Act.

Reporting Requirement

The information in Attachment 1 must be filled out and returned with this form.

Signed



Signature of Authorized Official

By

Robin K. Crumbaker

Type Name of Authorized Official



CERTIFICATE OF LIABILITY INSURANCE

OP ID CM
PLEAS-6

DATE (MM/DD/YYYY)

04/21/10

| | | |
|--|---|---------------|
| PRODUCER United Security Agency 2420 Garfield Avenue Parkersburg WV 26101 Phone: 304-295-8533 Fax: 304-295-9232 | THIS CERTIFICATE IS ISSUED AS A MATTER OF INFORMATION ONLY AND CONFERS NO RIGHTS UPON THE CERTIFICATE HOLDER. THIS CERTIFICATE DOES NOT AMEND, EXTEND OR ALTER THE COVERAGE AFFORDED BY THE POLICIES BELOW. | |
| | INSURERS AFFORDING COVERAGE | NAIC # |
| INSURED PLEASANT AIR HEATING & COOLING ROBIN CRUMBAKER 5200 EMERSON AVENUE PARKERSBURG WV 26104-9202 | INSURER A: MOTORISTS MUTUAL INSURANCE CO | 14621 |
| | INSURER B: | |
| | INSURER C: | |
| | INSURER D: | |
| | INSURER E: | |

COVERAGES

THE POLICIES OF INSURANCE LISTED BELOW HAVE BEEN ISSUED TO THE INSURED NAMED ABOVE FOR THE POLICY PERIOD INDICATED. NOTWITHSTANDING ANY REQUIREMENT, TERM OR CONDITION OF ANY CONTRACT OR OTHER DOCUMENT WITH RESPECT TO WHICH THIS CERTIFICATE MAY BE ISSUED OR MAY PERTAIN, THE INSURANCE AFFORDED BY THE POLICIES DESCRIBED HEREIN IS SUBJECT TO ALL THE TERMS, EXCLUSIONS AND CONDITIONS OF SUCH POLICIES. AGGREGATE LIMITS SHOWN MAY HAVE BEEN REDUCED BY PAID CLAIMS.

| INSR ADD'L LTR INSRD | TYPE OF INSURANCE | POLICY NUMBER | POLICY EFFECTIVE DATE (MM/DD/YYYY) | POLICY EXPIRATION DATE (MM/DD/YYYY) | LIMITS | |
|----------------------|--|---------------|------------------------------------|-------------------------------------|--|------------|
| A | GENERAL LIABILITY | 33279030-11E | 04/06/10 | 04/06/11 | EACH OCCURRENCE | \$ 1000000 |
| | <input checked="" type="checkbox"/> COMMERCIAL GENERAL LIABILITY | | | | DAMAGE TO RENTED PREMISES (Ea occurrence) | \$ 1000000 |
| | <input type="checkbox"/> CLAIMS MADE <input checked="" type="checkbox"/> OCCUR | | | | MED EXP (Any one person) | \$ 5000 |
| | | | | | PERSONAL & ADV INJURY | \$ 1000000 |
| | | | | | GENERAL AGGREGATE | \$ 2000000 |
| | | | | | PRODUCTS - COM/PROP AGG | \$ 2000000 |
| | | | | | GEN'L AGGREGATE LIMIT APPLIES PER: <input type="checkbox"/> POLICY <input type="checkbox"/> PRO-JECT <input type="checkbox"/> LOC | |
| A | AUTOMOBILE LIABILITY | 33279030-11E | 04/06/10 | 04/06/11 | COMBINED SINGLE LIMIT (Ea accident) | \$ 1000000 |
| | <input checked="" type="checkbox"/> ANY AUTO | | | | BODILY INJURY (Per person) | \$ |
| | <input type="checkbox"/> ALL OWNED AUTOS | | | | BODILY INJURY (Per accident) | \$ |
| | <input type="checkbox"/> SCHEDULED AUTOS | | | | PROPERTY DAMAGE (Per accident) | \$ |
| | <input checked="" type="checkbox"/> HIRED AUTOS | | | | | |
| | <input checked="" type="checkbox"/> NON-OWNED AUTOS | | | | | |
| | GARAGE LIABILITY | | | | AUTO ONLY - EA ACCIDENT | \$ |
| | <input type="checkbox"/> ANY AUTO | | | | OTHER THAN AUTO ONLY: EA ACC AGG | \$ |
| A | EXCESS / UMBRELLA LIABILITY | 33279030-11E | 04/06/10 | 04/06/11 | EACH OCCURRENCE | \$ 2000000 |
| | <input checked="" type="checkbox"/> OCCUR <input type="checkbox"/> CLAIMS MADE | | | | AGGREGATE | \$ |
| | <input type="checkbox"/> DEDUCTIBLE | | | | | \$ |
| | <input checked="" type="checkbox"/> RETENTION \$ 0 | | | | | \$ |
| | | | | | | \$ |
| A | WORKERS COMPENSATION AND EMPLOYERS' LIABILITY | 33279030-11E | 04/06/10 | 04/06/11 | WC STATUTORY LIMITS | OTHER |
| | ANY PROPRIETOR/PARTNER/EXECUTIVE OFFICER/MEMBER EXCLUDED? (Mandatory in NH) | | | | E.L. EACH ACCIDENT | \$ 1000000 |
| | If yes, describe under SPECIAL PROVISIONS below | | | | E.L. DISEASE - EA EMPLOYEE | \$ 1000000 |
| | | | | | E.L. DISEASE - POLICY LIMIT | \$ 1000000 |
| A | Property Section | 33279030-11E | 04/06/10 | 04/06/11 | | |

DESCRIPTION OF OPERATIONS / LOCATIONS / VEHICLES / EXCLUSIONS ADDED BY ENDORSEMENT / SPECIAL PROVISIONS

CERTIFICATE HOLDER

CANCELLATION

SHOULD ANY OF THE ABOVE DESCRIBED POLICIES BE CANCELLED BEFORE THE EXPIRATION DATE THEREOF, THE ISSUING INSURER WILL ENDEAVOR TO MAIL *30 DAYS WRITTEN NOTICE TO THE CERTIFICATE HOLDER NAMED TO THE LEFT, BUT FAILURE TO DO SO SHALL IMPOSE NO OBLIGATION OR LIABILITY OF ANY KIND UPON THE INSURER, ITS AGENTS OR REPRESENTATIVES.

AUTHORIZED REPRESENTATIVE

Chelsea Mollahan

STATE OF WEST VIRGINIA
Purchasing Division

PURCHASING AFFIDAVIT

West Virginia Code §5A-3-10a states: No contract or renewal of any contract may be awarded by the state or any of its political subdivisions to any vendor or prospective vendor when the vendor or prospective vendor or a related party to the vendor or prospective vendor is a debtor and the debt owed is an amount greater than one thousand dollars in the aggregate.

DEFINITIONS:

"Debt" means any assessment, premium, penalty, fine, tax or other amount of money owed to the state or any of its political subdivisions because of a judgment, fine, permit violation, license assessment, defaulted workers' compensation premium, penalty or other assessment presently delinquent or due and required to be paid to the state or any of its political subdivisions, including any interest or additional penalties accrued thereon.

"Debtor" means any individual, corporation, partnership, association, limited liability company or any other form or business association owing a debt to the state or any of its political subdivisions. "Political subdivision" means any county commission; municipality; county board of education; any instrumentality established by a county or municipality; any separate corporation or instrumentality established by one or more counties or municipalities, as permitted by law; or any public body charged by law with the performance of a government function or whose jurisdiction is coextensive with one or more counties or municipalities. "Related party" means a party, whether an individual, corporation, partnership, association, limited liability company or any other form or business association or other entity whatsoever, related to any vendor by blood, marriage, ownership or contract through which the party has a relationship of ownership or other interest with the vendor so that the party will actually or by effect receive or control a portion of the benefit, profit or other consideration from performance of a vendor contract with the party receiving an amount that meets or exceed five percent of the total contract amount.

EXCEPTION: The prohibition of this section does not apply where a vendor has contested any tax administered pursuant to chapter eleven of this code, workers' compensation premium, permit fee or environmental fee or assessment and the matter has not become final or where the vendor has entered into a payment plan or agreement and the vendor is not in default of any of the provisions of such plan or agreement.

Under penalty of law for false swearing (*West Virginia Code §61-5-3*), it is hereby certified that the vendor affirms and acknowledges the information in this affidavit and is in compliance with the requirements as stated.

WITNESS THE FOLLOWING SIGNATURE

Vendor's Name: PLEASANT AIR

Authorized Signature: [Signature] Date: 4-21-10

State of West Virginia

County of Wood, to-wit:

Taken, subscribed, and sworn to before me this 21 day of April, 2010.

My Commission expires April 29, 2018.

AFFIX SEAL HERE

NOTARY PUBLIC [Signature]

