



State of West Virginia
 Department of Administration
 Purchasing Division
 2019 Washington Street East
 Post Office Box 50130
 Charleston, WV 25305-0130

Request for Quotation

REQ NUMBER
ABCA167

PAGE
1

ADDRESS CORRESPONDENCE TO ATTENTION OF
SHELLY MURRAY
304-558-8801

PURCHASING

H&K Equipment, Inc.
4200 Casteel Drive
Coraopolis, PA 15108

SHIP TO

ALCOHOL BEVERAGE CONTROL
COMMISSION
322 70TH STREET, S.E.
CHARLESTON, WV
25304-2900 558-2487

DATE PRINTED	TERMS OF SALE	SHIP VIA	FOB	FREIGHT TERMS
06/02/2010				

BID OPENING DATE: **06/17/2010** BID OPENING TIME **01:30PM**

LINE	QUANTITY	UOP	CAT NO	ITEM NUMBER	UNIT PRICE	AMOUNT
0001	1	LS		365-50	\$17,861.00 \$4,909.00	\$22,770.00
<p>RE-BID OF ABCA126</p> <p>THE WEST VIRGINIA PURCHASING DIVISION, FOR THE AGENCY, THE WEST VIRGINIA ALCOHOL BEVERAGE CONTROL ADMINISTRATION, IS SOLICITING BIDS FOR A SWEEPER/ SCRUBBER PER THE ATTACHED SPECIFICATIONS.</p> <p>SHIP TO : ALCOHOL BEVERAGE CONTROL COMMISSION HUB INDUSTRIAL PARK RIVER ROAD NITRO, WV 25143 558-2487</p> <p>CANCELLATION: THE DIRECTOR OF PURCHASING RESERVES THE RIGHT TO CANCEL THIS CONTRACT IMMEDIATELY UPON WRITTEN NOTICE TO THE VENDOR IF THE COMMODITIES AND/OR SERVICES SUPPLIED ARE OF AN INFERIOR QUALITY OR DO NOT CONFORM WITH THE SPECIFICATIONS OF THE BID AND CONTRACT HEREIN.</p> <p>BANKRUPTCY: IN THE EVENT THE VENDOR/CONTRACTOR FILES FOR BANKRUPTCY PROTECTION, THIS CONTRACT IS AUTOMATICALLY NULL AND VOID, AND IS TERMINATED WITHOUT FURTHER ORDER.</p> <p>NOTICE</p>						

RECEIVED

2010 JUN 14 AM 9:43

WV PURCHASING DIVISION

SEE REVERSE SIDE FOR TERMS AND CONDITIONS

SIGNATURE	TELEPHONE	DATE
TITLE	FEIN	ADDRESS CHANGES TO BE NOTED ABOVE

WHEN RESPONDING TO RFQ, INSERT NAME AND ADDRESS IN SPACE ABOVE LABELED 'VENDOR'



State of West Virginia
 Department of Administration
 Purchasing Division
 2019 Washington Street East
 Post Office Box 50130
 Charleston, WV 25305-0130

Request for Quotation

RFQ NUMBER
ABCA167

PAGE
2

ADDRESS CORRESPONDENCE TO ATTENTION OF
SHELLY MURRAY 304-558-8801

RFQ COPY
 TYPE NAME/ADDRESS HERE

VENDOR

SHIP TO

ALCOHOL BEVERAGE CONTROL
 COMMISSION
 322 70TH STREET, S.E.
 CHARLESTON, WV
 25304-2900 558-2487

DATE PRINTED	TERMS OF SALE	SHIP VIA	F.O.B.	FREIGHT TERMS
06/02/2010				

BID OPENING DATE: 06/17/2010 BID OPENING TIME 01:30PM

LINE	QUANTITY	UOP	CAT NO	ITEM NUMBER	UNIT PRICE	AMOUNT
<p>A SIGNED BID MUST BE SUBMITTED TO:</p> <p>DEPARTMENT OF ADMINISTRATION PURCHASING DIVISION BUILDING 15 2019 WASHINGTON STREET, EAST CHARLESTON, WV 25305-0130</p> <p>THE BID SHOULD CONTAIN THIS INFORMATION ON THE FACE OF THE ENVELOPE OR THE BID MAY NOT BE CONSIDERED:</p> <p>SEALED BID</p> <p>BUYER: SHELLY MURRAY</p> <p>RFQ. NO.: ABCA167</p> <p>BID OPENING DATE: 06/17/2010</p> <p>BID OPENING TIME: 1:30 PM</p> <p>PLEASE PROVIDE A FAX NUMBER IN CASE IT IS NECESSARY TO CONTACT YOU REGARDING YOUR BID: 412-494-0975</p> <p>-----</p> <p>CONTACT PERSON (PLEASE PRINT CLEARLY): <i>R STEPHEN MCGINNIS</i></p> <p>-----</p>						

SEE REVERSE SIDE FOR TERMS AND CONDITIONS

SIGNATURE	TELEPHONE	DATE
-----------	-----------	------

TITLE	FEIN	ADDRESS CHANGES TO BE NOTED ABOVE
-------	------	-----------------------------------

WHEN RESPONDING TO RFQ. INSERT NAME AND ADDRESS IN SPACE ABOVE LABELLED 'VENDOR'

Request for Quotation
WEST VIRGINIA ALCOHOL CONTROL ADMINISTRATION
Sweeper-Scrubber Unit
Requisition Number:
ABCA167

1.0 **Scope:**

1.1 The specifications are intended to cover all requirements for the purchase of a Scrubber-Sweeper system to be used at the West Virginia Alcohol Beverage Control Administration, Warehouse located in Nitro, WV.

2.0 **Specifications:**

- 2.1 Successful bidder, hereafter "Supplier" shall furnish a scrubber-sweeper, all necessary attachments and delivery of said unit to the WVABCA Warehouse. The "Supplier" shall provide the following specifications on the aforementioned unit:
- 2.1.1 Must have a minimum cleaning path of 32 inches (including side and sweeping brush).
 - 2.1.2 Is to have no more than four cylindrical brushes and no less than two.
 - 2.1.3 Shall possess the ability to place down pressure on the brushes to allow more pressure to be applied on desired spots.
 - 2.1.4 Shall be equipped with a side sweeping brush.
 - 2.1.5 Shall be equipped with a squeegee that is equipped with a breakaway feature.
 - 2.1.6 Shall be equipped with a system that raises the squeegee when the unit is placed in reverse.
 - 2.1.7 Shall allow the operator to control the amount of water used to scrub or squeegee.
 - 2.1.8 Shall be capable of picking up small debris such as wood chips, glass fragments, paper and plastic fragments.
 - 2.1.9 Shall be capable of scrubbing and dry sweeping.
 - 2.1.10 Must have a minimum of 36 volt battery system and must come equipped with a battery charger.
 - 2.1.11 Must be equipped with an hour meter and battery discharge meter.
 - 2.1.12 Shall have fuse protection on its circuitry.
 - 2.1.13 Shall have an adjustable seat and a seatbelt.
 - 2.1.14 The driver's seat shall be mounted at the front portion of the scrubber-sweeper to allow for maximum line of sight by the driver.
 - 2.1.15 Shall have a solution tank with a minimum capacity of 40 gallons.
 - 2.1.16 Shall have a recovery tank with a minimum capacity of 50 gallons.

- 2.1.17 Shall have drain valves that allow for hose connections on the solution and recovery tanks. The connections will allow the operator to fill and empty the aforementioned tanks.
- 2.1.18 Shall be equipped with a dust filter that may be changed with minimal tools.
- 2.1.19 Shall have a debris hopper that is equipped with a minimum of 70 pounds of capacity.
- 2.1.20 Shall be equipped with hazard lights that may be engaged while the unit is in motion.
- 2.1.21 Shall be accompanied by a parts manual and an operations manual.
- 2.1.22 The "Supplier" must deliver the scrubber-sweeper to the WVABCA Warehouse located at 500 River Road, Hub Industrial Park, Nitro, WV 25143. Delivery costs must be included in the price of the equipment.
- 2.1.23 Equipment cost must be inclusive of manufacturer's warranty.

3.0 **Submitting:**

- 3.1 The Vendor should submit the following with bid proposals but must submit prior to award:
 - 3.1.1 Manufacturer's warranty, specifications on all items, operation and maintenance manuals.

4.0 Acceptance and Testing Requirements:

- 4.1.1 Upon delivery of the scrubber-sweeper the "Supplier" shall demonstrate the units functions and demonstrate that the equipment is in working order prior to acceptance by the agency. Warranty period will become effective upon agency acceptance via change order.

RFQ No. _____

STATE OF WEST VIRGINIA
Purchasing Division

PURCHASING AFFIDAVIT

West Virginia Code §5A-3-10a states: No contract or renewal of any contract may be awarded by the state or any of its political subdivisions to any vendor or prospective vendor when the vendor or prospective vendor or a related party to the vendor or prospective vendor is a debtor and the debt owed is an amount greater than one thousand dollars in the aggregate.

DEFINITIONS:

"Debt" means any assessment, premium, penalty, fine, tax or other amount of money owed to the state or any of its political subdivisions because of a judgment, fine, permit violation, license assessment, defaulted workers' compensation premium, penalty or other assessment presently delinquent or due and required to be paid to the state or any of its political subdivisions, including any interest or additional penalties accrued thereon.

"Debtor" means any individual, corporation, partnership, association, limited liability company or any other form or business association owing a debt to the state or any of its political subdivisions. "Political subdivision" means any county commission; municipality; county board of education; any instrumentality established by a county or municipality; any separate corporation or instrumentality established by one or more counties or municipalities, as permitted by law; or any public body charged by law with the performance of a government function or whose jurisdiction is coextensive with one or more counties or municipalities. "Related party" means a party, whether an individual, corporation, partnership, association, limited liability company or any other form or business association or other entity whatsoever, related to any vendor by blood, marriage, ownership or contract through which the party has a relationship of ownership or other interest with the vendor so that the party will actually or by effect receive or control a portion of the benefit, profit or other consideration from performance of a vendor contract with the party receiving an amount that meets or exceed five percent of the total contract amount.

EXCEPTION: The prohibition of this section does not apply where a vendor has contested any tax administered pursuant to chapter eleven of this code, workers' compensation premium, permit fee or environmental fee or assessment and the matter has not become final or where the vendor has entered into a payment plan or agreement and the vendor is not in default of any of the provisions of such plan or agreement.

Under penalty of law for false swearing (*West Virginia Code* §61-5-3), it is hereby certified that the vendor affirms and acknowledges the information in this affidavit and is in compliance with the requirements as stated.

WITNESS THE FOLLOWING SIGNATURE

Vendor's Name: _____

Authorized Signature: *R. Hoge* Date: _____

State of Pennsylvania

County of Allegheny, to-wit:

Taken, subscribed, and sworn to before me this 11 day of June, 2010.

My Commission expires November 18, 2013.

AFFIX SEAL HERE

NOTARY PUBLIC

Tracy Yellig

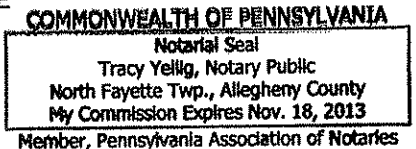

State of West Virginia

VENDOR PREFERENCE CERTIFICATE

Certification and application* is hereby made for Preference in accordance with West Virginia Code, §5A-3-37. (Does not apply to construction contracts). West Virginia Code, §5A-3-37, provides an opportunity for qualifying vendors to request (at the time of bid) preference for their residency status. Such preference is an evaluation method only and will be applied only to the cost bid in accordance with the West Virginia Code. This certificate for application is to be used to request such preference. The Purchasing Division will make the determination of the Resident Vendor Preference, if applicable.

- 1. Application is made for 2.5% resident vendor preference for the reason checked: Bidder is an individual resident vendor and has resided continuously in West Virginia for four (4) years immediately preceding the date of this certification; or, Bidder is a partnership, association or corporation resident vendor and has maintained its headquarters or principal place of business continuously in West Virginia for four (4) years immediately preceding the date of this certification; or 80% of the ownership interest of Bidder is held by another individual, partnership, association or corporation resident vendor who has maintained its headquarters or principal place of business continuously in West Virginia for four (4) years immediately preceding the date of this certification; or, Bidder is a nonresident vendor which has an affiliate or subsidiary which employs a minimum of one hundred state residents and which has maintained its headquarters or principal place of business within West Virginia continuously for the four (4) years immediately preceding the date of this certification; or,
2. Application is made for 2.5% resident vendor preference for the reason checked: Bidder is a resident vendor who certifies that, during the life of the contract, on average at least 75% of the employees working on the project being bid are residents of West Virginia who have resided in the state continuously for the two years immediately preceding submission of this bid; or,
3. Application is made for 2.5% resident vendor preference for the reason checked: Bidder is a nonresident vendor employing a minimum of one hundred state residents or is a nonresident vendor with an affiliate or subsidiary which maintains its headquarters or principal place of business within West Virginia employing a minimum of one hundred state residents who certifies that, during the life of the contract, on average at least 75% of the employees or Bidder's affiliate's or subsidiary's employees are residents of West Virginia who have resided in the state continuously for the two years immediately preceding submission of this bid; or,
4. Application is made for 5% resident vendor preference for the reason checked: Bidder meets either the requirement of both subdivisions (1) and (2) or subdivision (1) and (3) as stated above; or,
5. Application is made for 3.5% resident vendor preference who is a veteran for the reason checked: Bidder is an individual resident vendor who is a veteran of the United States armed forces, the reserves or the National Guard and has resided in West Virginia continuously for the four years immediately preceding the date on which the bid is submitted; or,
6. Application is made for 3.5% resident vendor preference who is a veteran for the reason checked: Bidder is a resident vendor who is a veteran of the United States armed forces, the reserves or the National Guard, if, for purposes of producing or distributing the commodities or completing the project which is the subject of the vendor's bid and continuously over the entire term of the project, on average at least seventy-five percent of the vendor's employees are residents of West Virginia who have resided in the state continuously for the two immediately preceding years.

Bidder understands if the Secretary of Revenue determines that a Bidder receiving preference has failed to continue to meet the requirements for such preference, the Secretary may order the Director of Purchasing to: (a) reject the bid; or (b) assess a penalty against such Bidder in an amount not to exceed 5% of the bid amount and that such penalty will be paid to the contracting agency or deducted from any unpaid balance on the contract or purchase order.

By submission of this certificate, Bidder agrees to disclose any reasonably requested information to the Purchasing Division and authorizes the Department of Revenue to disclose to the Director of Purchasing appropriate information verifying that Bidder has paid the required business taxes, provided that such information does not contain the amounts of taxes paid nor any other information deemed by the Tax Commissioner to be confidential.

Under penalty of law for false swearing (West Virginia Code, §61-5-3), Bidder hereby certifies that this certificate is true and accurate in all respects; and that if a contract is issued to Bidder and if anything contained within this certificate changes during the term of the contract, Bidder will notify the Purchasing Division in writing immediately.

Bidder: _____ Signed: _____
Date: _____ Title: _____

*Check any combination of preference consideration(s) indicated above, which you are entitled to receive.



H & K EQUIPMENT, INC.
4200 Casteel Drive • Coraopolis, PA 15108-9725
(412) 490-5300 Phone • (412) 494-0975 Main Fax
www.hkequipment.com

June 11, 2010

State of West Virginia
Alcohol Beverage Control Commission
322 70th Street, S.E.
Charlestown, WV

Subject: Sweeper/Scrubber Quotation

Shelly Murray:

Enclosed is information on a Factory Cat XR-34 Cylindrical rider scrubber/sweeper and a Factory Cat 34 walk-behind sweeper.

The idea is that it is a more complete system than a cylindrical scrubber with a sweeper attachment added. The dual machine process is:

- **More effective, as each machine is doing it's designed function**
- **Less expensive**
- **Less susceptible to damage, as the sweeper attachment adds length to the base unit**
- **More flexible, as the size of the equipment is not impacted by the sweeper attachment**

If you should have any questions, please let me know. Thank you for the opportunity.

Very truly yours,

H & K EQUIPMENT CO., INC.

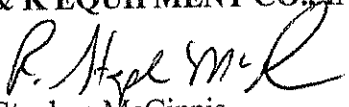
R. Stephen McGinnis
Enclosures

Let's arrange a demonstration!



H&K Equipment, Inc.
4200 Casteel Drive · Coraopolis, PA 15108-9725
(412) 490-5300 Phone · (412) 494-0975 Main Fax
www.hkequipment.com

06/11/10
Attention: Shelly Murray
Factory Cat 34
Battery Powered Walk-Behind Sweeper
\$ 4,909.00 +tax/freight

STANDARD EQUIPMEN INCLUDES:

All Steel Body
34" Sweep Path
2 Cubic Foot Heavy Duty Hopper
Black Rubber Tires
Self-Propelled, 0-3 mph
Heavy Duty Dust Control-Industrial Polymer Felt Filter
Manual Crank Filter Shaker
Upgraded Long-Life heavy-duty Deep Cycle Battery
Built-in Fully Automatic Battery Charger (plugs into 110v outlet)
Self-Adjusting, Full-Floating Main Broom (your choice of bristle type)
Adjustable Stainless Steel Handle
Retractable Side Broom for Sweeping Edges/Corners
Fully Protected Side Broom (by 7.0 gauge heavy-duty front bumpers)
Low Voltage Warning Light
Hood operated safety Switch

Warranties: 36-Month Parts & 12- Months Labor

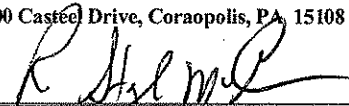
ACCEPTANCE OF PROPOSAL	CUSTOMER P.O. #: _____
H & K EQUIPMENT CO., INC. 4200 Casteel Drive, Coraopolis, PA 15108	DATE OF ORDER: _____
 _____ R. Stephen McGinnis	State of West Virginia Charleston, WV 25305-0130 _____ (Authorized Signature & Company Position)

FACTORY CAT

MODEL 34
MODEL 48
SWEEPERS



FAMILY OF INDUSTRIAL CLEANING EQUIPMENT (21" - 55')

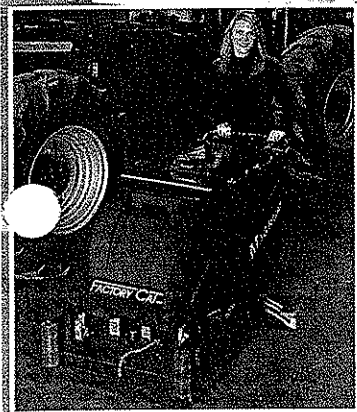

BUILT FOR INDUSTRIAL CLEANING

Factory Cat's sweepers are built to sweep factories: dirt, dust, metal shavings, foundry sand, bolts, paper, wood, whatever there is. **Factory Cats** are **compact**, not light-duty.

These machines are **all-steel**, and use oversized components throughout. At your in-plant inspection, you'll see top quality componentry, hefty fabrications, oversized motors, and nearly 100% stainless steel fasteners.

Factory Cat's side brooms pick up dirt in the corners. A huge tubular main broom under the machine sweeps up the dirt and debris from the floor and packs it into the steel hopper.

Meanwhile, the second stage vacuums up the dust and traps it in a polypropylene felt "baghouse" filter. **Factory Cats** can pick up whole bags of cement at a time without leaving a trace of dust behind. The filter is cleaned by an on-board mechanism, and in most cases will last the life of the machine.

Factory Cat's "Central Command" energy management system gives our silent, **electric** rider sweepers the power formerly available from only gasoline or propane-powered machines.

The 48 is the most powerful compact battery-powered sweeper and can run a full shift on a charge.

MAKES YOU MONEY FROM DAY ONE

Few production machines can save you as much as a **Factory Cat** sweeper. If you do not now use a power sweeper, **Model 48 will cut your labor costs for sweeping by a factor of ten or more.**

These direct labor savings permit tremendous economy, even in small plants. The Model 48 can sweep some 500,000 sq. ft. in one shift, and on a single charge.

Factory Cat 48 rider is priced much lower than you think – less than many walk-behind machines, and a fraction of the cost of most other riders.

SPECIALISTS NOT NEEDED

Factory Cats could not be much simpler to operate. Controls are smooth and simple, and maintenance is a snap; just put the machine on charge after every shift. No oil to change, brooms to reverse, fuel to spill, tanks to exchange, valves to grind.

TEST SWEEP – NO COST OR OBLIGATION

Why not have your people try cleaning your plant with a Model 34 or 48? It's free, and there's no obligation. Call us at **800-634-4060** to set up a demonstration that is convenient for you.

HIGH PERFORMANCE CLEANING

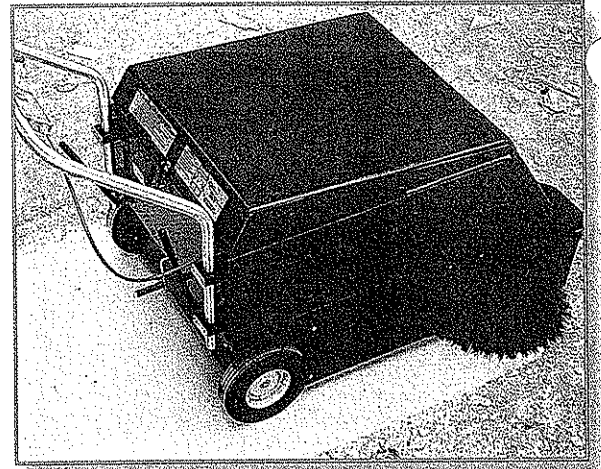

SWEEPS INDOORS



4 FOOT SWEEP PATH

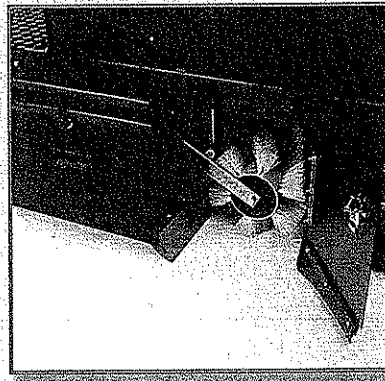

MODEL 37

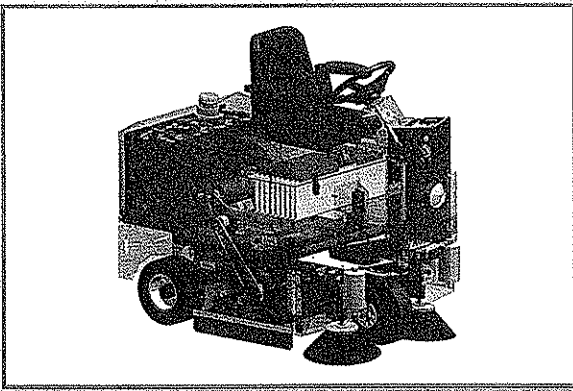

MODEL 48

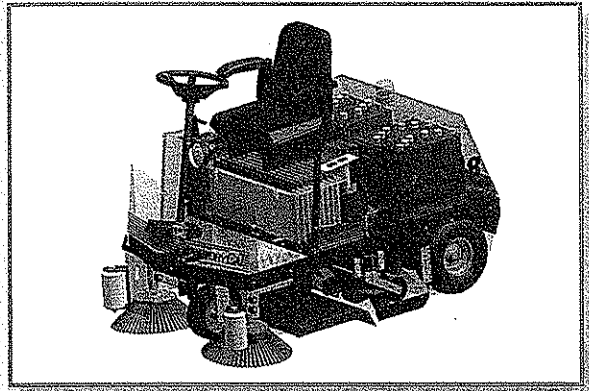

Productivity Comparison *(square feet/hour)*

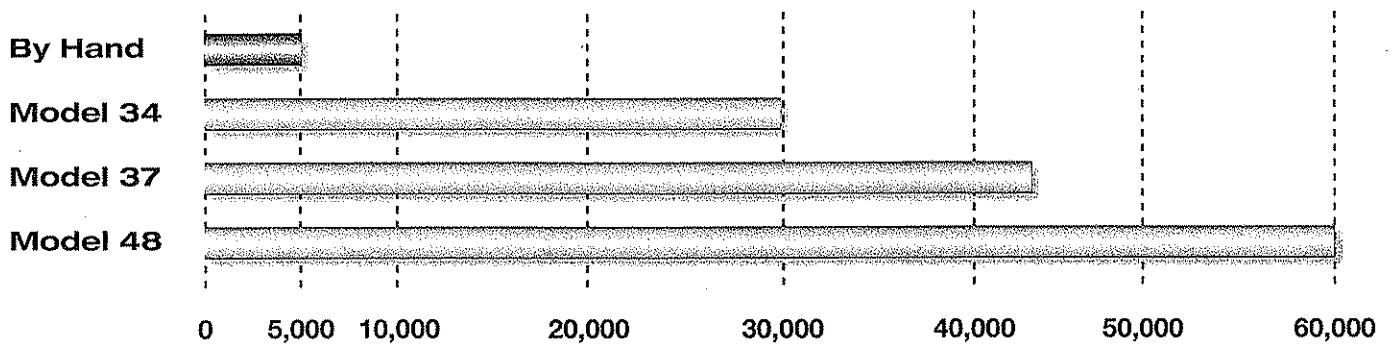

- SELF PROPELLED OPERATOR EASE
- STAINLESS HANDLEBAR FULLY ADJUSTABLE
- OVERSIZED BATTERY EXTENDS RUN TIME
- ON BOARD CHARGER PERMITS REMOTE CHARGING
- BAGHOUSE FILTER HIGH CAPACITY & LONG LIFE
- ALL STEEL CONSTRUCTION DURABLE
- 900 LB. CAPACITY CASTER IMPROVED MANEUVERABILITY
- LARGE/POWERFUL SIDE BROOM INCREASES PRODUCTIVITY
- SELF ADJUSTING MAIN BROOM REDUCES MAINTENANCE
- 1/2 TON CAPACITY TIRE LONG LASTING
- 10" DIAMETER MAIN BROOM IMPROVED SWEEPING

RETURN ON INVESTMENT

AREA Sq. Ft.	TIME REQUIRED TO CLEAN		Monthly Labor Savings
	By Hand	Model 48	
50,000	10 hrs	0.80 hrs	\$ 487.00
75,000	15 hrs	1.25 hrs	\$1,345.00
100,000	20 hrs	1.67 hrs	\$3,587.00
250,000	50 hrs	4.10 hrs	\$9,435.00

SOLD ONLY THROUGH DEALERS

We've built our reputation by providing the toughest, best-engineered, highest-value machines our industry can produce. We make sure that in every market in which our more than 300 distributors and service centers do business, they maintain a "factory" trained service department with a vested interest in our customers long-term satisfaction.

Factory Cat offers a line of cleaning equipment that includes sweepers and scrubbers, in both walk-behind and ride on models. All our models are practical, rugged machines that are sensibly priced. Your local dealer will be happy to assist you with rentals, soap, and floor sealer information. They will gladly provide service on all brands of cleaning equipment.

GUARANTEED SERVICE

We guarantee to supply you with the spare parts you need within three work days — or they're yours free. This guarantee applies only to the 48 contiguous states of the United States, at the customer's special request, and to parts that can be shipped by courier.



R.P.S. Corporation
P.O. Box 368
Racine, Wisconsin 53401-9966
Toll Free: 1-800-634-4060
Phone: (262) 681-3583
Fax: (866) 901-3335
www.factorycat.com

Model	Walk Behind 34	Riders 37/48
Construction		
Frame:	1/8" Steel	3/16" Steel
Drive Wheels:	10" x 3"	37: (1) 12" x 4" 48: (2) 15" x 4"
Other Wheels:	5" x 2" (caster)	37: (2) 12" x 5" 48: (1) 10" x 4"
Dimensions (L x W x H):	58" x 31" x 38"	37: 59" x 30" x 50" 48: 64" x 37" x 50"
Weight:	450 lbs	850 lbs
Sweeping System		
Sweeping Method:	Direct Throw	Direct Throw
Broom (length x dia):	26" x 10"	37: 25" x 10" 48: 32" x 10"
Broom Power/Speed:	1.0 hp/400 rpm	1.0 hp/400 rpm
Side Broom Size:	(1) 17"	37: (2) 14" 48: (2) 17"
Side Broom Power:	(1) 0.3 hp	(2) 0.3 hp
Side Broom Speed:	65 rpm	100 rpm
Hopper Capacity:	2.0 cubic ft	37: 2.0 cubic ft 48: 4.0 cubic ft
Battery System		
Battery Run Time:	3 to 5 hours	5 to 9 hours
Charger (110v/60 Hz, auto):	25 amp	36 amp
Filtering System		
Filtering Material:	Polymer Felt	Polymer Felt
Filter Rating:	1 Micron	1 Micron
Size:	5,182 sq. inches	5,182 sq. inches
Vacuum Rating:	250 cfm	250 cfm
Drive System		
Drive Power:	1.0 hp	2.0 hp
Speed Control:	0 to 3 mph	0 to 4 mph
Productivity		
Cleaning Width:	33"	37: 37" 48: 48"
Cleaning Rate:	30,000 ft/hr	37: 46,220 ft/hr 48: 60,568 ft/hr
General		
Sound Level:	70 dBA	71 dBA
Standard Equipment:	Low Battery Indicator	Headlight, Horn, Auto Parking Brake
Optional Equipment:	HD Bumper	Strobe, Back-up Alarm, Overhead Guard

AUTHORIZED DISTRIBUTOR



H & K EQUIPMENT, INC.
 4200 Casteel Drive
 Coraopolis, PA 15108-9725

412.490.5300 phone
 412.494.0975 fax

www.hkequipment.com

PS34 (04/06)



H&K Equipment, Inc.
4200 Casteel Drive · Coraopolis, PA 15108-9725
(412) 490-5300 Phone · (412) 494-0975 Main Fax
www.hkequipment.com

06/11/10

Attention: Shelly Murray
Factory Cat XR-34 Battery Powered Rider Scrubber/Sweeper
\$ 17,861.00 plus tax/freight

STANDARD EQUIPMEN INCLUDES:

34" Cylindrical scrub path
"Central Command II" Energy Management System
3.0 HP All-Gear Front Wheel Drive
68-Gallon Polyethylene Solution Tank with Solution Level Indicator
68-Gallon Polyethylene Recovery Tank with 2" Drain Hose
Disc: Two .75 HP/ 300 rpm Gear Drive Brush Motors, with 2 Brushes
Dual (650 Watt) 3-Stage Vacuum Motor
7-Gage (3/16") All-Steel Frame, with large Poly Rollers
Powder Paint Finish—16 times more corrosion resistant than enamel
Automatic brush pressure control, with 5 settings from 0 to 350 lbs.
36 volt/325 AH Trojan Battery Pack/36 amp automatic charger
L.C.D. readout for trouble shooting with diagnostic codes
L.C.D readout for solution flow, brush pressure, battery gauge, & (3) hour meters
Horn, Back-up alarm & Dual Headlights, Rear Bumper
Low Solution and High Recovery Warning Lights
Operator & Parts Manual & Nearly 100% Stainless Steel Fasteners
Heavy Duty Tires (Front and Rear) for Chemical Resistance
Warranties: 36-Month Parts & 12 Months Labor

Options Included: Dual side sweeping broom system, seat switch, flashing light

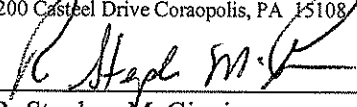
ACCEPTANCE OF PROPOSAL	CUSTOMER P.O. #: _____
DATE OF ORDER: _____	State of West Virginia
H & K EQUIPMENT CO., INC. 4200 Casteel Drive Coraopolis, PA 15108	Charleston, WV 25304
	_____
R. Stephen McGinnis	(Authorized Signature & Company Position)

FACTORY CAT

MADE IN U.S.A.

XR Series Rider Scrubbers



FAMILY OF INDUSTRIAL CLEANING EQUIPMENT (17" - 48")

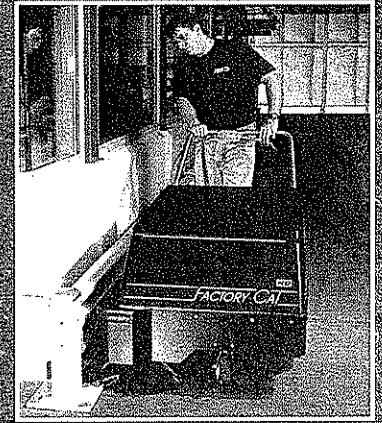
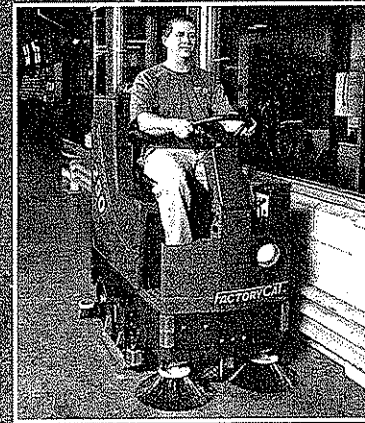

FACTORY CAT XR SCRUBBERS

These rugged and high performance scrubbers offer the productivity of the industry's largest equipment, but in a more maneuverable package.

With two specialized cleaning systems and five deck sizes to choose from, **FACTORY CATS XRs** offer the results and capacity required to clean your unique application.

The "Disk" XRs offer gimbaled brush drive and 45% more scrubbing power than competitive brands. The "Cylindrical" units reduce or eliminate dust mopping, by sweeping and scrubbing in a single pass.

The scrub decks include adjustable wipers and curtains, for unmatched water control. All components are made of heavy gauge steel for durability and accessibility is designed in to simplify service work.

PRODUCTIVITY

Productivity is a function of scrub path, run time and tank capacity, and **FACTORY CATS** top the chart.

1. Larger Tanks (68 gallons) = Less stopping to refill
2. Wider Scrub Path (46") = Fewer trips down the aisle
3. High Down Pressure = Less double scrubbing
4. Twin Vacuum Motors = Dry, safe, clean floors
5. Big Battery = Runs a full shift

EASY TO SERVICE

Any manufacturer can claim to build equipment that is both tough and easy to clean up, but we actually do and invite you to compare other equipment. Your maintenance staff will notice the difference immediately.

Tank Tips

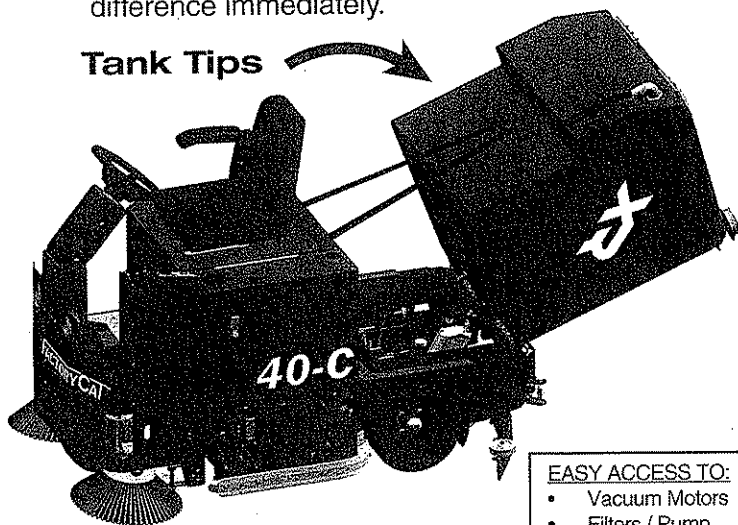

EASY ACCESS TO:

- Vacuum Motors
- Filters / Pump
- Valves
- Actuators

FREE DEMO (800) 634-4060



MAINTENANCE SCREEN

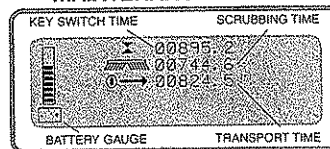

Large Lid
Complete Access
to Clean

OPERATING SCREEN

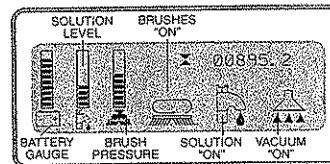

Large Tanks (68 gallons)
Increased Productivity

Massive Steel Frame
Durability in HD Applications

Heavy Duty Tires
Optimum Stability & Traction

Oversized Motors
Superior Cleaning & Long Lasting

Disk Decks
Excellent VCT
Performance

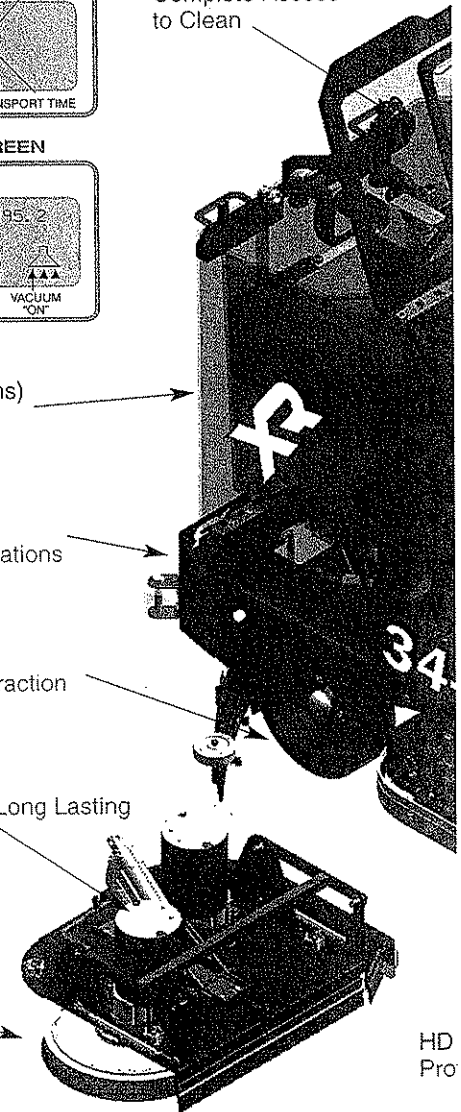

HD
Pro

ERGONOMIC DESIGN

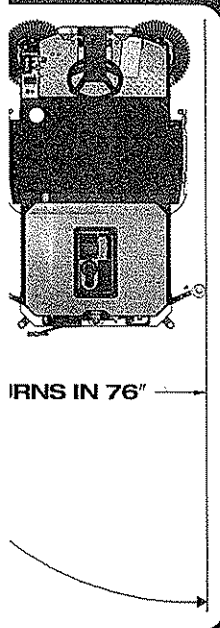
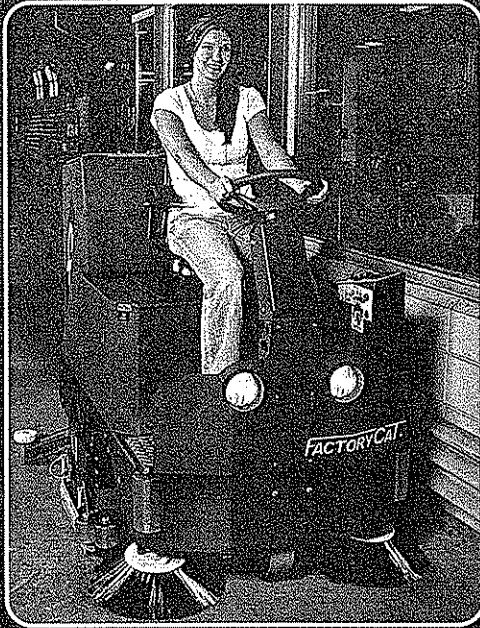

FACTORY CAT XR SCRUBBERS

The operator sits in a spring-suspension, fully adjustable, mid-back chair. The adjustable steering column, armrests, and front guard further enhance operator comfort and safety. With a powerful drive motor, these machines can climb steep ramps, and come standard with heavy duty tires. Features include an automatic parking brake, and reduction of transport speed while scrubbing or backing up.

Our Central Command II system includes an LCD readout, on-board diagnostics, and three hour meters, simplifying preventive maintenance intervals. When the batteries discharge, the machine automatically shuts down all systems except "transport" to allow you to return to the charge station or any standard 20A outlet with the optional onboard charger.

BUILT TOUGH

FACTORY CATS use powerful motors, which typically run at only 50% of their capacity. This leaves power in reserve for times where heavy scrubbing is required, and prolongs motor life.

- Constructed of thick steel, and powder-painted to prevent corrosion.
- Tanks have extra-thick walls and brass inserts for strength.
- Tall polyurethane rollers disperse collision forces without leaving marks on your walls.
- **FACTORY CATS** use only stainless fasteners.

Drain Saver
Keeps Debris
Out of Drains

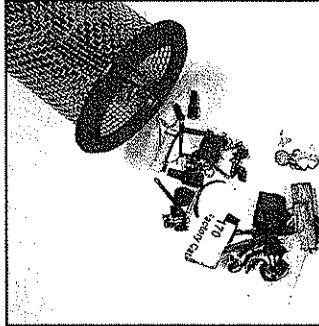

Adjustable Seat
& Steering
Operator Comfort

Big Batteries
Extended Run Time

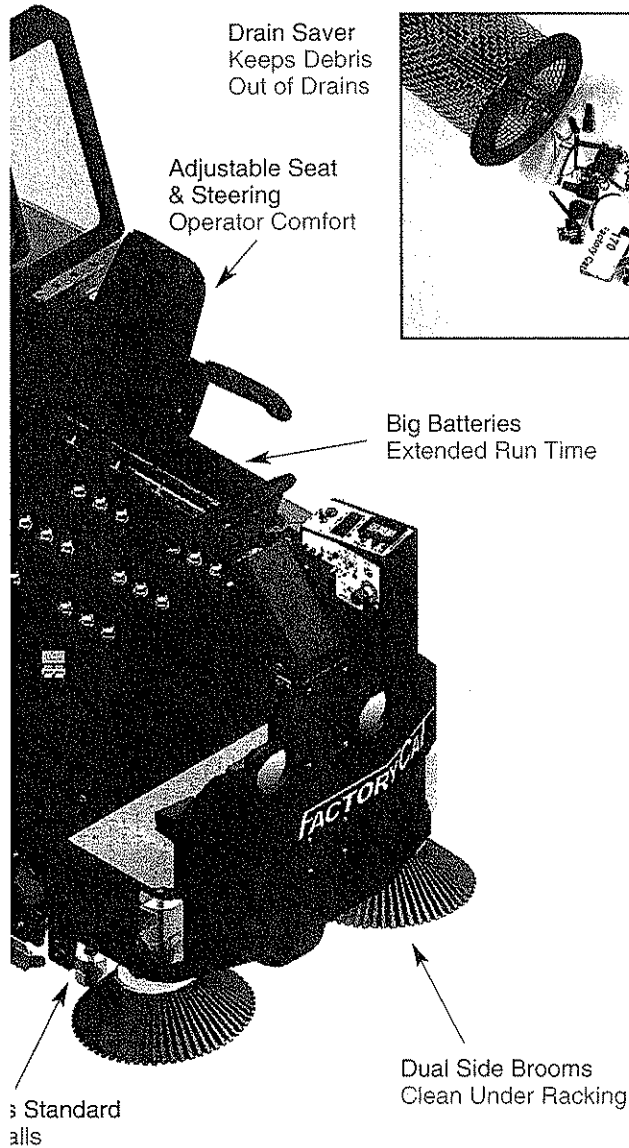

POPULAR OPTIONS

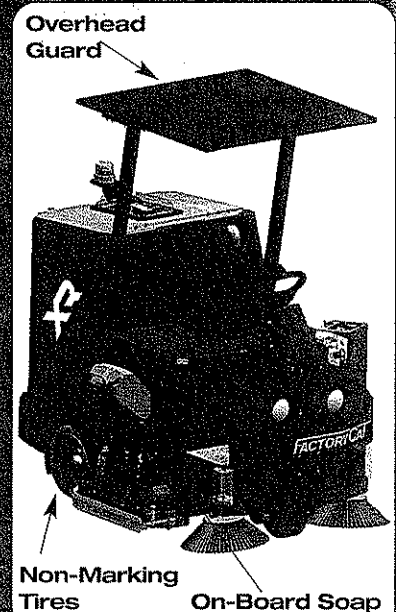
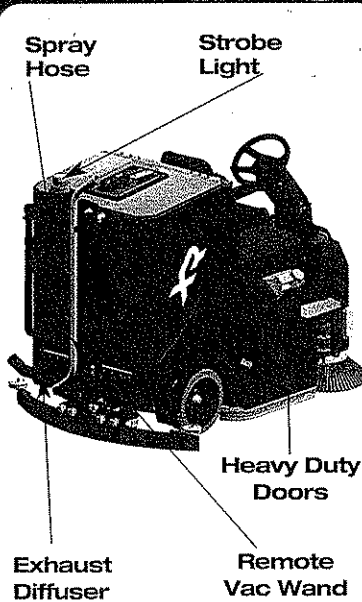

EXPERIENCED DISTRIBUTORS

FACTORY CAT continues to grow by providing the toughest machines in our industry, at a reasonable investment. Our 300 distributors each maintain a factory-trained service department and diverse rental fleet, which allow them to continue serving your needs.

We offer a line of cleaning equipment that includes sweepers and scrubbers in both walk-behind and rider models. All **FACTORY CAT** machines are practical, rugged and sensibly priced. We can happily provide leasing information to those customers who prefer it.

Quality chemicals are a vital component to any cleaning program, so feel free to contact us with questions about "Approved" chemicals for use in our equipment.

GUARANTEED SERVICE

We guarantee to supply you the spare parts you need within three workdays, or they are yours free. This applies only to the 48 contiguous states, at the customer's special request, and to parts that can be shipped by courier.

AUTHORIZED DISTRIBUTOR



H & K EQUIPMENT, INC.
4200 Casteel Drive
Coraopolis, PA 15108-9725

412.490.5300 phone
412.494.0975 fax

www.hkequipment.com

R.P.S. Corporation
P.O. Box 368 • Racine, WI 53401; USA
Phone: (800) 634-4060
Fax: (866) 901-3335
www.factorycat.com

Copyright R.P.S. Corporation 2008. All rights reserved. Since our policy is one of constant improvement, all specifications are subject to change without notice.

Body Construction/Dimensions

Tank Material:	Poly (3/8" thick)
Frame Construction:	7-gauge (3/16" Steel)
Rear Wheels (diameter x width):	14" x 5"
Drive Wheel (diameter x width):	12" x 4"
Size (L x W x H):	69" x 36" x 56"
Weight:	1,230 pounds
Weight (w / standard batteries):	1,950 pounds

Brush/Pad System

Brush Down Pressure:	0-350 pounds
Brush Pressure Settings:	(5) w / auto adjust

DISK

Brush / Pad Size:	370-34D: (2) 17" 370-40D: (2) 20"
Brush Speed:	270-rpm
Motor Power:	(2) 1.5 hp

CYLINDRICAL

Brush Size:	370-34C: (2) 32" x 7" 370-40C: (2) 38" x 7" 370-46C: (2) 44" x 7"
Brush Speed	750-rpm
Motor Power:	(2) 1.5 hp

Battery System

Battery AH Rating (standard):	(Qty 6) 325 AH
Battery AH Rating (optional):	(Qty 6) 395 AH
Battery AH Rating (industrial Battery):	(Qty 1) 440 AH / 1,245 lbs.
Battery Run Time	Up to 6 hours
Charger (110-v / 60 hz, auto):	36-v / 36-amp

Solution System

Solution Tank Capacity:	68-gallons
Solution Flow Rate:	0-1.5 gpm
Solution Filter:	Inline Stainless

Recovery System

Recovery Tank Capacity:	68-gallons
Vacuum Power	1.6 hp
Vacuum (lift / airflow)	68" / 140 cfm
Demisting Chamber:	2.5 gallons

Drive System

Power:	*3.0 hp, sealed
Type:	All Gear
Speed Control:	0-5 mph

General

Sound Levels:	71 dBA
Side Boom Path:	45"
Cleaning Width / Productivity:	370-34: 34"/36,720 sq. ft./hr. 370-40: 40"/43,200 sq. ft./hr. 370-46: 46"/49,680 sq. ft./hr.

Optional Equipment

- Maintenance Free Batteries
- Spray Hose
- Vacuum Wand
- Side Brooms
- Industrial Battery (440 ah)
- 85 Gallon Stainless Tanks
- Removable Battery System
-  Onboard Soap
- Onboard Charger
- Non-Marking Tires
- HD Package (Side Doors)
- Overhead Guard
- Variety of Brushes and Squeegees