



State of West Virginia
 Department of Administration
 Purchasing Division
 2019 Washington Street East
 Post Office Box 50130
 Charleston, WV 25305-0130

Request for Quotation

RFQ NUMBER
ABCA140

PAGE
1

ADDRESS CORRESPONDENCE TO ATTENTION OF:
SHELLY MURRAY
304-558-8801

***308134424 01 304-776-6900**
M H EQUIPMENT CO
126 LAKEVIEW DR
CHARLESTON WV 25313

ALCOHOL BEVERAGE CONTROL
COMMISSION
HUB INDUSTRIAL PARK
RIVER ROAD
NITRO, WV
25143 558-2487

DATE PRINTED	TERMS OF SALE	SHIP VIA	F.O.B.	FREIGHT TERMS
04/18/2010				
BID OPENING DATE: 05/27/2010		BID OPENING TIME 01:30PM		

LINE	QUANTITY	UOP	CAT. NO.	ITEM NUMBER	UNIT PRICE	AMOUNT
<p>THE WEST VIRGINIA PURCHASING DIVISION, FOR THE AGENCY, THE WEST VIRGINIA ALCOHOL BEVERAGE CONTROL ADMINISTRATION, IS SOLICITING BIDS FOR SIX (6) BATTERY POWERED HAND TRUCK WALKIE/RIDERS PER THE ATTACHED SPECIFICATIONS.</p> <p>TECHNICAL QUESTIONS MUST BE SUBMITTED IN WRITING TO SHELLY MURRAY IN THE WEST VIRGINIA PURCHASING DIVISION VIA MAIL AT THE ADDRESS SHOWN AT THE TOP OF THIS RFQ, VIA FAX AT 304-558-4115, OR VIA E-MAIL AT SHELLY.L.MURRAY@WV.GOV. DEADLINE FOR ALL TECHNICAL QUESTIONS IS 05/12/2010 AT THE CLOSE OF BUSINESS. ALL TECHNICAL QUESTIONS RECEIVED, IF ANY, WILL BE ADDRESSED BY ADDENDUM AFTER THE DEADLINE.</p>						
0001	6	EA		075-41	\$ 7,704.34 each	\$ 46,226.04
<p>CANCELLATION: THE DIRECTOR OF PURCHASING RESERVES THE RIGHT TO CANCEL THIS CONTRACT IMMEDIATELY UPON WRITTEN NOTICE TO THE VENDOR IF THE COMMODITIES AND/OR SERVICES SUPPLIED ARE OF AN INFERIOR QUALITY OR DO NOT CONFORM WITH THE SPECIFICATIONS OF THE BID AND CONTRACT HEREIN</p> <p>BANKRUPTCY: IN THE EVENT THE VENDOR/CONTRACTOR FILES FOR BANKRUPTCY PROTECTION, THIS CONTRACT IS AUTOMATICALLY NULL AND VOID, AND IS TERMINATED WITHOUT FURTHER ORDER.</p> <p>THE MODEL/BRAND/SPECIFICATIONS NAMED HEREIN ESTABLISH</p>						

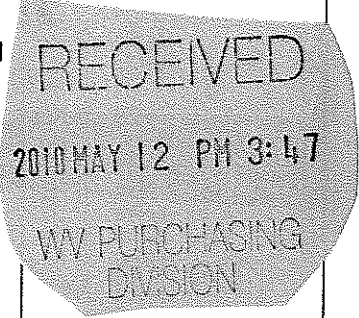

SEE REVERSE SIDE FOR TERMS AND CONDITIONS

SIGNATURE: *[Signature]* TELEPHONE: 304 776 6900 DATE: 5/6/10

TITLE: Sales Representative FEIN: 14-1858601 ADDRESS CHANGES TO BE NOTED ABOVE

WHEN RESPONDING TO RFQ, INSERT NAME AND ADDRESS IN SPACE ABOVE LABELED 'VENDOR'



State of West Virginia
 Department of Administration
 Purchasing Division
 2019 Washington Street East
 Post Office Box 50130
 Charleston, WV 25305-0130

Request for Quotation

RFQ NUMBER:
ABCA140

PAGE:
2

ADDRESS CORRESPONDENCE TO ATTENTION OF:
**SHELLY MURRAY
 304-558-8801**

***308134424 01 304-776-6900**
M H EQUIPMENT CO
126 LAKEVIEW DR

CHARLESTON WV 25313

ALCOHOL BEVERAGE CONTROL
COMMISSION
HUB INDUSTRIAL PARK
RIVER ROAD
NITRO, WV
25143 558-2487

DATE PRINTED	TERMS OF SALE	SHIP VIA	F.O.B.	FREIGHT TERMS
04/18/2010				

BID OPENING DATE: **05/27/2010** BID OPENING TIME **01:30PM**

LINE	QUANTITY	UOP	CAT. NO.	ITEM NUMBER	UNIT PRICE	AMOUNT
<p>THE ACCEPTABLE LEVEL OF QUALITY ONLY AND ARE NOT INTENDED TO REFLECT A PREFERENCE OR FAVOR ANY PARTICULAR BRAND OR VENDOR. VENDORS WHO ARE BIDDING ALTERNATES SHOULD SO STATE AND INCLUDE PERTINENT LITERATURE AND SPECIFICATIONS. FAILURE TO PROVIDE INFORMATION FOR ANY ALTERNATES MAY BE GROUNDS FOR REJECTION OF THE BID. THE STATE RESERVES THE RIGHT TO WAIVE MINOR IRREGULARITIES IN BIDS OR SPECIFICATIONS IN ACCORDANCE WITH SECTION 148-1-4(F) OF THE WEST VIRGINIA LEGISLATIVE RULES AND REGULATIONS.</p> <p style="text-align: center;">NOTICE</p> <p>A SIGNED BID MUST BE SUBMITTED TO:</p> <p style="padding-left: 40px;">DEPARTMENT OF ADMINISTRATION PURCHASING DIVISION BUILDING 15 2019 WASHINGTON STREET, EAST CHARLESTON, WV 25305-0130</p> <p>THE BID SHOULD CONTAIN THIS INFORMATION ON THE FACE OF THE ENVELOPE OR THE BID MAY NOT BE CONSIDERED:</p> <p>SEALED BID</p> <p>BUYER: SHELLY MURRAY</p> <p>RFQ. NO.: ABCA140</p> <p>BID OPENING DATE: 05/27/2010</p>						

SEE REVERSE SIDE FOR TERMS AND CONDITIONS

SIGNATURE	TELEPHONE	DATE
<i>[Signature]</i>		
TITLE	FEIN	ADDRESS CHANGES TO BE NOTED ABOVE

WHEN RESPONDING TO RFQ, INSERT NAME AND ADDRESS IN SPACE ABOVE LABELED 'VENDOR'

**ABCA140
SPECIFICATIONS FOR BATTERY POWERED HAND TRUCK WALKIE/RIDER
SIX (6) UNITS**

UNIT MUST BE EQUAL TO HYSTER MODEL B60ZAC

LOAD CAPACITY	6000 LBS MINIMUM
FORK LENGTH	48 INCHES - APPROXIMATE
LOWERED FORK HEIGHT	3.25 INCHES - APPROXIMATE
FORK SPRED	27 INCHES - APPROXIMATE
ELEVATED FORK HEIGHT	9.3 INCHES - APPROXIMATE
INDIVIDUAL FORK WIDTH	9.0 INCHES - APPROXIMATE
LIFT	6.0 INCHES - APPROXIMATE
DRIVE WHEELS	10" X 5" CROWNED POLY – APPROXIMATE HEIGHT
LOAD WHEELS	3.25" X 6.5" POLY – APPROXIMATE HEIGHT
CASTER WHEELS	4" X 2.5" POLY – APPROXIMATE HEIGHT
ANTI-FATIGUE FLOOR MAT	REQUIRED
BATTERY CONNECTOR	SB 175 RED - REQUIRED
BATTERY – 24 VOLT	510 AMP HOURS – NOT TAR SEALED - REQUIRED
SERVICE MANUAL	REQUIRED
PARTS MANUAL	REQUIRED
CONTROL HANDLE WITH DAMPENED RETURN	- REQUIRED
BATTERY DISCHARGE INDICATOR WITH HOUR METER	- REQUIRED
12 MONTH/2000 HOUR WARRANTY	- REQUIRED
LOAD BACK REST	- NOT REQUIRED

MH EQUIP OF OHIO SOUTH
126 LAKEVIEW DRIVE
CHARLESTON, WV - 25313

RFQ: ABCA140

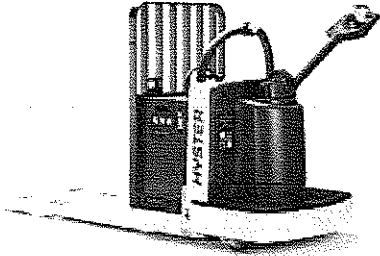

BILL TO:
STATE OF WV PURCHASING DI
DEPT OF ADMINISTRATION
2019 WASHINGTON ST EAST
CHARLESTON, WV -25305-0130

Quote To: Ms. Shelly Murray
Quote No: 78-19660178
Series: B230
Model: B60ZAC
Quantity: 1
Date: 06 May 2010
Expires: 30 Jun 2010

MODEL/OPTION DESCRIPTION

MODEL: B60ZAC
PALLET FORKS: 48" LONG X 27" WIDE
VOLTAGE: 24 VOLT
BATTERY TYPE: FLOODED CELL
STANDARD CONSTRUCTION
BATTERY CONNECTOR: 175 AMP RED
CASTERS: 4" X 2.5" POLY SPRING LOADED
DRIVE TIRE: 10" X 5" - SMOOTH POLY 90D
STEERING TYPE: MANUAL
LOAD WHL: 3.25" X 6.5" SGL POLY W/2 BRGS
START SWITCH: KEY IGNITION SWITCH
PARTS MANUAL: PRINTED
LITERATURE PACKET & LABELS: ENGLISH
WARRANTY: USA STD WTY 12MO/2000 HOURS

Total Selling Price(Each): \$7,704.34
Total Selling Price(Extended): \$7,704.34

Price Includes: General 12-85G-13, 24 Volt, 510 AH Industrial Battery with Cover.

SIGNATURE



DATE

5/6/10

APPROVAL

DATE



Walkie/Rider Motorized Hand Pallet Truck

B60Z^{AC} Series

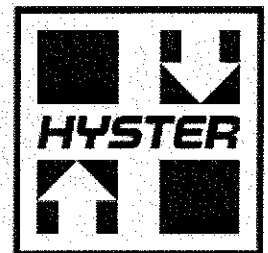

The Safe Choice

PRODUCTIVITY:

The Hyster B60Z^{AC} is the simplest way to boost your productivity. It is easy to operate, has minimal service requirements and works smartly.

- Truck features a full six inches of lift height for easy maneuverability over uneven floor surfaces and across dock plates.
- The short head length and design of the control handle allows for the best turning radius and right angle stacking capabilities in its class.
- Pace setting travel speeds allow more loads to be moved per hour.
- A high performance hydraulic system, coupled with the advanced pallet entry/exit system, produces outstanding cycle times.
- Optional Coast Control with Side Glide feature enhances operator performance and productivity while increasing low level order picking efficiency.
 - Coast Control available with Advanced activation or Manual activation.
- Power Assist Steer option helps operators move heavy loads through tight turns and crowded loading areas with ease.
- Operator selectable, programmable performance modes enable the truck to be tailored to the application or operator skill level.
- AC traction controller provides improved torque, increased travel speeds and allows smoother acceleration and directional changes.
- Extended Shift Feature:
 - With Extended Shift “ON”, truck performance is tailored with “energy efficiency” in mind, allowing the truck to operate longer between battery charges.
 - With Extended Shift “OFF”, parameters are adjusted with high performance in mind, allowing quicker acceleration and directional changes, for faster cycle times resulting in increased throughput and productivity.

DEPENDABILITY:

The B60Z^{AC} sets the standard for long-lasting, worry free operation. Every detail is designed by Hyster engineers to make sure you can always deliver – and never get left holding the load.

- CANbus communication system significantly reduces the number of wires required in the electrical system, and links the control handle, display, controller and Power Assist Steer (option) together enhancing overall truck reliability.
- Steel reinforced control handle is durable, impact resistant and easy to service.
- Electro-mechanical brake has no linkage to adjust and maintain.
- Electronic horn provides high volume, consistent operation and long life.
- AC traction transistor controller eliminates motor brushes and directional contactors, creating a reliable product with minimal maintenance requirements.
- Integrated transistor pump control provides a “soft start” feature by eliminating the high in-rush current associated with contactors and, therefore, extends the service life of the pump motor.
- The AC system uses less energy than SEM systems, increasing overall truck performance while decreasing battery charge intervals.

ERGONOMICS:

The superior ergonomic design of the new B60Z^{AC} walkie/rider product means greater comfort for your operator. A comfortable operator is a more productive operator.

- Unique control handle design features left hand and right hand controls which allow finger tip control of lift/lower, travel and the horn functions with either hand.
- Coast Control with Side Glide feature eliminates climbing on/off during quick pick applications.
- Activation buttons for the optional Advanced Coast Control are conveniently positioned on each side of the steer handle for easy, effortless thumb operation from either side of the truck.
- 1-inch thick rubber floor mat absorbs shock from uneven floor surfaces or dock plates enhancing operator comfort when riding.
- Power Assist Steer option requires less effort from the operator, reducing fatigue and enhancing truck maneuverability.
- Padded and contoured steady rest provides a soft and comfortable grab point, increasing operator stability while riding.
- Low step height provides quick and easy on/off access for operator, reducing fatigue during the work shift.
- Large operator area provides comfortable and productive positioning.
- Ergonomically angled handgrips and contoured control handle provide a comfortable grip and enhance the maneuverability.



RAISING THE STANDARD FOR LIFT TRUCKS

Floor Mat: 1-inch thick rubber floor mat absorbs shock from uneven floor surfaces or dock plates enhancing operator comfort when riding.

Control Handle: The short head length and design of the control handle allows for the best turning radius and right angle stacking capabilities in its class.

Steady Rest: Padded and contoured to provide a soft and comfortable grab point, increasing operator stability while riding.

Load Backrest: Available in 48", 60", and 72" heights (bolt-on or pivoting).

Lift Height: Truck features a full six inches of lift height for easy maneuverability over uneven floor surfaces and across dock plates.

Brake: Electro-mechanical brake has no linkage to adjust and maintain.

Trucks shown with optional equipment.

STANDARD EQUIPMENT

48" Long Forks
27" Fork Spread
Standard Construction Operating Temperatures: +32° F to +120° F
Smooth Polyurethane Drive Tire – 90 Durometer – 10" x 5.0"
Single Polyurethane Load Wheels – 3.25" x 6.5"
Standard Duty Casters – Polyurethane Wheels
Manual Steering
Key Ignition Switch
24 Volt Transistor Control Electrical System
AC Traction Motor (Brushless)
Operator Selectable, Programmable Performance Modes
Integrated "Soft Start" Transistor Lift Pump Control
ADS (Auto Deceleration System) w/Regenerative Braking
Extended Shift Feature
31.25" x 13.4" Open Battery Compartment
Electro-Mechanical Park Brake
UL Classification Type "E"
Electronic Horn
Impact Resistant, Steel Reinforced, Ergonomic Control Handle
Pallet Exit Rollers/Entry Skids
Knock-Out Load Wheel Axles
6" Lift Height
Boxed Fork Construction with Reinforced Fork Tips
Flush Pallet Stop
Long Life Lift Linkage
Multi-Function Display
 Battery State of Charge
 Hour Meter
 Low Battery Lift Interrupt
 Performance Mode Indicator
 Fault Indicator
On-Board Software
 Test and Diagnose
 No Handset Required
 Password Protected

OPTIONAL EQUIPMENT

Power Assist Steer
Battery Rollers
Convenience Tray (Load Backrest Mounted or Battery Mounted)
RF Terminal Power Supply – 24 Volt
Audible Alarm
Visible Alarm – Pole Mounted Amber Strobe
Advanced Coast Control with Side Glide
Manual Coast Control with Side Glide
Casters
 Heavy Duty
 Heavy Duty with SEALED Wheel and Swivel Bearings
Fork Lengths
 36" Long Forks
 42" Long Forks
 60" Long Forks
Drive Tire
 Rubber – 65 Durometer
 Siped Polyurethane – 90 Durometer
Load Wheels
 Single and Dual
 2 Bearing and 4 Bearing
 Standard Bearing and SEALED Bearing
Load Backrest
 48" High (Pivoting or Bolt-on)
 60" High (Pivoting or Bolt-on)
 72" High (Bolt-on)
Application/Environmental Construction
Cooler/Freezer Package
 Operating Temperatures: 0° F to +120° F
subZERO Freezer Package
 Operating Temperatures: -40° F to +120° F

B60Z^{AC}

Bottom line? You need pallet trucks that can get the job done without a lot of fuss. The 6,000-lb. capacity B60Z^{AC} motorized hand pallet walkie/rider does just that. With its advanced productivity, exceptional durability and superior maneuverability, it's easy to see how the B60Z^{AC} can turn even your tough jobs into just another task.

DIMENSIONS

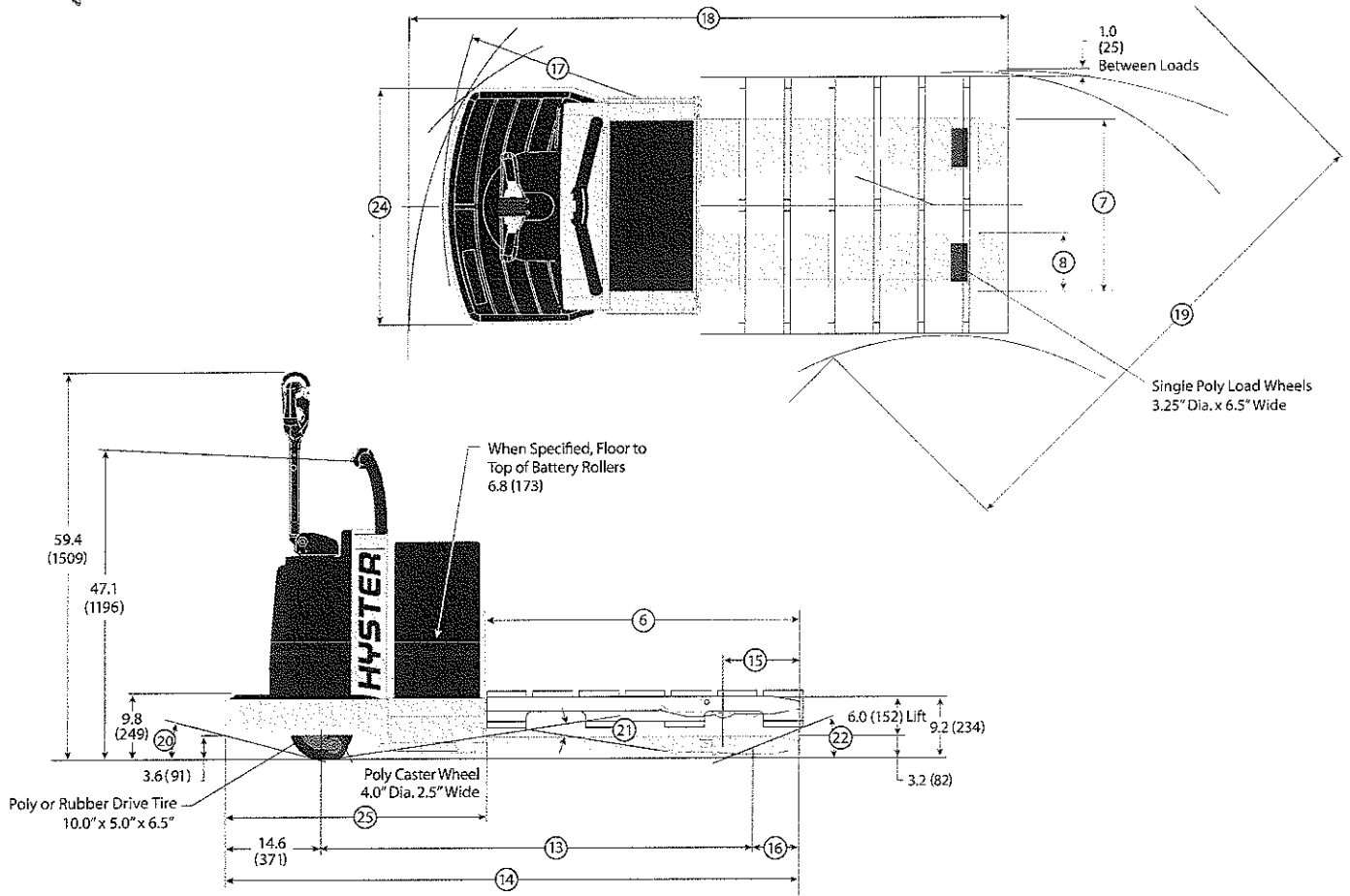

Circled dimensions correspond to the line numbers on the tabulated chart inside the Technical Guide. Dimensions are in inches (millimeters).

GMA Pallet - Standard Dimensions

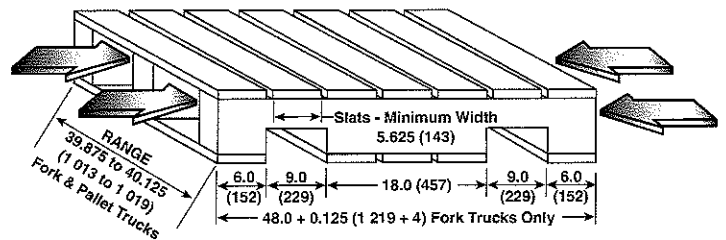

BATTERY SPECIFICATIONS							
Number of Cells	Cell Size	Plates per Cell	Capacity 6 Hr Rate amp hr (kwh)	Battery Dimensions			Weight lb. (kg)
				"X"	"Y"	"Z"	
12	75	7	225 (5.2)	25.7 (652)	8.8 (224)	23.3 (592)	540 (245)
12	85	7	255 (6.0)	25.7 (652)	8.8 (224)	23.3 (592)	570 (259)
12	75	11	375 (8.7)	26.5 (673)	13.0 (330)	23.3 (592)	825 (374)
12	85	11	425 (9.9)	26.5 (673)	13.0 (330)	23.3 (592)	865 (392)
12	75	13	450 (10.5)	30.9 (785)	13.0 (330)	23.3 (592)	987 (448)
12	85	13	510 (11.9)	30.9 (785)	13.0 (330)	23.3 (592)	1035 (469)
12	100	13	600 (14.0)	30.9 (785)	13.0 (330)	26.2 (665)	1140 (517)

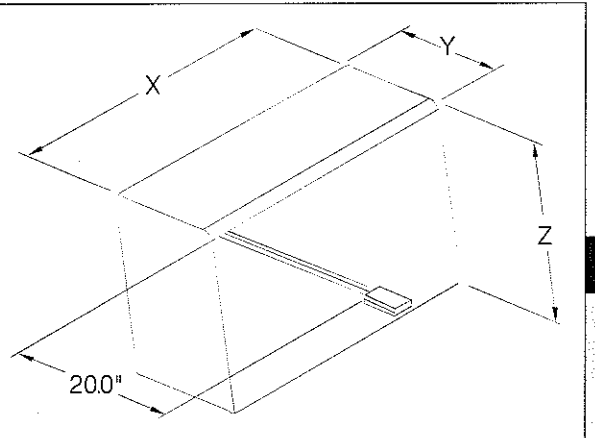

Battery Connector: 175 Amp, Red • Battery Lead Length 20" (508 mm), Position "B", 1/0 AWG

SPECIFICATIONS

7

		HYSTER COMPANY						
		B60Z ^{AC}						
		Battery - 24 Volt						
		Walk / Stand Ride						
		6000 (2722)						
GENERAL			lb (kg)					
1	Manufacturer		HYSTER COMPANY					
2	Model Designation		B60Z ^{AC}					
3	Power		Battery - 24 Volt					
4	Operation		Walk / Stand Ride					
5	Rated Capacity		6000 (2722)					
6	Fork Length	Nominal	in (mm)	36 (914)	42 (1067)	48 (1219)	60 (1524)	
		Actual	in (mm)	35.75 (908)	41.75 (1060)	47.75 (1213)	59.75 (1518)	
7	Fork Overall Width		in (mm)	27.0 (686)	27.0 (686)	27.0 (686)	27.0 (686)	
8	Fork Width - Individual Fork		in (mm)	9.1 (231)	9.1 (231)	9.1 (231)	9.1 (231)	
9	Load Distance	(Face of Forks to Center of Load Wheel)	Lowered	in (mm)	28.75 (730)	34.75 (883)	40.75 (1035)	52.75 (1340)
10	Truck Weight	Without Battery	No Load	lb (kg)	1237 (561)	1257 (570)	1272 (577)	1302 (591)
11	Axle Loading - Drive	Static with Max. Wt. Battery	Rated Load	lb (kg)	2268 (1029)	2566 (1164)	2807 (1273)	3212 (1457)
		Static with Max. Wt. Battery	No Load	lb (kg)	1541 (699)	1601 (726)	1649 (748)	1760 (798)
12	Axle Loading - Load Wheel	Static with Max. Wt. Battery	Rated Load	lb (kg)	6109 (2771)	5831 (2645)	5605 (2542)	5230 (2372)
		Static with Max. Wt. Battery	No Load	lb (kg)	836 (379)	796 (361)	763 (346)	682 (309)
13	Wheelbase - No Load Backrest or with Pivoting Load Backrest		Raised	in (mm)	49.2 (1250)	55.2 (1402)	61.2 (1554)	73.2 (1859)
	Wheelbase - No Load Backrest or with Pivoting Load Backrest		Lowered	in (mm)	53.8 (1367)	59.8 (1519)	65.8 (1671)	77.8 (1976)
	Wheelbase - With Bolt-On Load Backrest		Raised	in (mm)	51.2 (1300)	57.2 (1453)	63.2 (1605)	75.2 (1910)
	Wheelbase - With Bolt-On Load Backrest		Lowered	in (mm)	55.8 (1417)	61.8 (1570)	67.8 (1722)	79.8 (2027)
14	Overall Length - No Load Backrest or with Pivoting Load Backrest			in (mm)	75.3 (1913)	81.3 (2065)	87.3 (2217)	99.3 (2522)
	Overall Length - With Bolt-On Load Backrest			in (mm)	77.3 (1963)	83.3 (2167)	89.3 (2268)	101.3 (2573)
15	Center of Load Wheel to Tip of Forks		Raised	in (mm)	11.7 (297)	11.7 (297)	11.7 (297)	11.7 (297)
	Center of Load Wheel to Tip of Forks		Lowered	in (mm)	7.0 (178)	7.0 (178)	7.0 (178)	7.0 (178)
	Outside Turning Radius - No Load Backrest or with Pivoting Load Backrest		Raised	in (mm)	63.6 (1615)	69.6 (1768)	75.6 (1920)	87.6 (2225)
	Outside Turning Radius - No Load Backrest or with Pivoting Load Backrest		Lowered	in (mm)	68.3 (1735)	74.3 (1887)	80.3 (2040)	92.3 (2344)
	Outside Turning Radius - With Bolt-On Load Backrest		Raised	in (mm)	65.6 (1666)	71.6 (1819)	77.6 (1971)	89.6 (2276)
	Outside Turning Radius - With Bolt-On Load Backrest		Lowered	in (mm)	70.3 (1786)	76.3 (1938)	82.3 (2090)	94.3 (2395)
	Right Angle Stack - No Load Backrest or with Pivoting Load Backrest		Raised	in (mm)	78.6 (1996)	83.7 (2126)	89.1 (2263)	100.0 (2540)
	Right Angle Stack - With Bolt-On Load Backrest		Raised	in (mm)	80.4 (2042)	85.4 (2169)	90.9 (2309)	101.8 (2586)
19	Equal Intersecting Aisle - No Load Backrest or with Pivoting Load Backrest		Raised	in (mm)	61.8 (1570)	64.9 (1648)	68.0 (1727)	74.3 (1887)
	Equal Intersecting Aisle - With Bolt-On Load Backrest		Raised	in (mm)	63.3 (1608)	66.5 (1689)	69.6 (1768)	75.9 (1928)
20	Grade Clearance		Chassis	%	26	26	26	26
21	Grade Clearance		Ctr of Wheelbase	%	39	34	31	25
22	Grade Clearance		Forks	%	39	39	39	39
23	Lift Height - Top of Fork	Lowered Ht / Raised Ht / Total Lift		in (mm)	3.2 / 9.2 / 6.0 (81 / 234 / 152)			
24	Truck Overall Width			in (mm)	36.9 (937)			
25	Chassis Length (Length of Face to Forks)			in (mm)	39.5 (1003)			
26	Battery Compartment - Length x Width x Height	Standard / with Battery Rollers		in (mm)	31.25 x 13.4 x OPEN (793 X 340 X OPEN)			
27	Travel Speed - Chassis First		No Load/Rated Load	mph (kph)	9.0 / 6.7 (14.5 / 10.8)			
	Travel Speed - Forks First		No Load/Rated Load	mph (kph)	6.0 / 5.2 (9.7 / 8.4)			
28	Drive Control		Type		AC			
29	Service Brake		Type		Electro-Mechanical			
30	Drive Tire	Size / Type (Number of Wheels)		in	10.0 x 5.0 x 6.5 / Poly (1)			
	Load Wheel	Size / Type (Number of Wheels)		in	3.25 x 6.25 / Poly (2)			
	Caster Wheel	Size / Type (Number of Wheels)		in	4.0 x 2.5 / Poly - Spring Loaded (2)			

Above specifications, unless otherwise listed, are for a standard truck without optional equipment.
 Right Angle Stack and Equal Intersecting Aisle are calculated using a 40" wide pallet.
 Grade Clearance measured to the bottom of the pallet with forks in a raised position.

CERTIFICATION: These Hyster® lift trucks meet design specifications of Part II ANSI B56.1-1969, as required by OSHA Section 1910.178(a)(2) and also comply with Part III ANSI B56.1-revision in effect at time of manufacture. Certification of compliance with the applicable ANSI standards appears on the lift truck.
NOTE: Performance specifications / ratings are for truck equipped as described under Standard Equipment in this Technical Guide. Performance specifications are affected by the condition of the vehicle and how it is equipped, as well as by the nature and condition of the operating area. Specifications are subject to change and the proposed application should be discussed with your authorized Hyster Dealer.

State of West Virginia VENDOR PREFERENCE CERTIFICATE

Certification and application* is hereby made for Preference in accordance with *West Virginia Code*, §5A-3-37. (Does not apply to construction contracts). *West Virginia Code*, §5A-3-37, provides an opportunity for qualifying vendors to request (at the time of bid) preference for their residency status. Such preference is an evaluation method only and will be applied only to the cost bid in accordance with the *West Virginia Code*. This certificate for application is to be used to request such preference. The Purchasing Division will make the determination of the Resident Vendor Preference, if applicable.

- 1. **Application is made for 2.5% resident vendor preference for the reason checked:**
 Bidder is an individual resident vendor and has resided continuously in West Virginia for four (4) years immediately preceding the date of this certification; **or**,
 Bidder is a partnership, association or corporation resident vendor and has maintained its headquarters or principal place of business continuously in West Virginia for four (4) years immediately preceding the date of this certification; or 80% of the ownership interest of Bidder is held by another individual, partnership, association or corporation resident vendor who has maintained its headquarters or principal place of business continuously in West Virginia for four (4) years immediately preceding the date of this certification; **or**,
 Bidder is a nonresident vendor which has an affiliate or subsidiary which employs a minimum of one hundred state residents and which has maintained its headquarters or principal place of business within West Virginia continuously for the four (4) years immediately preceding the date of this certification; **or**,
- 2. **Application is made for 2.5% resident vendor preference for the reason checked:**
 Bidder is a resident vendor who certifies that, during the life of the contract, on average at least 75% of the employees working on the project being bid are residents of West Virginia who have resided in the state continuously for the two years immediately preceding submission of this bid; **or**,
- 3. **Application is made for 2.5% resident vendor preference for the reason checked:**
 Bidder is a nonresident vendor employing a minimum of one hundred state residents or is a nonresident vendor with an affiliate or subsidiary which maintains its headquarters or principal place of business within West Virginia employing a minimum of one hundred state residents who certifies that, during the life of the contract, on average at least 75% of the employees or Bidder's affiliate's or subsidiary's employees are residents of West Virginia who have resided in the state continuously for the two years immediately preceding submission of this bid; **or**,
- 4. **Application is made for 5% resident vendor preference for the reason checked:**
 Bidder meets either the requirement of both subdivisions (1) and (2) or subdivision (1) and (3) as stated above; **or**,
- 5. **Application is made for 3.5% resident vendor preference who is a veteran for the reason checked:**
 Bidder is an individual resident vendor who is a veteran of the United States armed forces, the reserves or the National Guard and has resided in West Virginia continuously for the four years immediately preceding the date on which the bid is submitted; **or**,
- 6. **Application is made for 3.5% resident vendor preference who is a veteran for the reason checked:**
 Bidder is a resident vendor who is a veteran of the United States armed forces, the reserves or the National Guard, if, for purposes of producing or distributing the commodities or completing the project which is the subject of the vendor's bid and continuously over the entire term of the project, on average at least seventy-five percent of the vendor's employees are residents of West Virginia who have resided in the state continuously for the two immediately preceding years.

Bidder understands if the Secretary of Revenue determines that a Bidder receiving preference has failed to continue to meet the requirements for such preference, the Secretary may order the Director of Purchasing to: (a) reject the bid; or (b) assess a penalty against such Bidder in an amount not to exceed 5% of the bid amount and that such penalty will be paid to the contracting agency or deducted from any unpaid balance on the contract or purchase order.

By submission of this certificate, Bidder agrees to disclose any reasonably requested information to the Purchasing Division and authorizes the Department of Revenue to disclose to the Director of Purchasing appropriate information verifying that Bidder has paid the required business taxes, provided that such information does not contain the amounts of taxes paid nor any other information deemed by the Tax Commissioner to be confidential.

Under penalty of law for false swearing (West Virginia Code, §61-5-3), Bidder hereby certifies that this certificate is true and accurate in all respects; and that if a contract is issued to Bidder and if anything contained within this certificate changes during the term of the contract, Bidder will notify the Purchasing Division in writing immediately.

Bidder: _____ Signed: _____

Date: _____ Title: _____

*Check any combination of preference consideration(s) indicated above, which you are entitled to receive.

RFQ No. ABCA 140

STATE OF WEST VIRGINIA
Purchasing Division

PURCHASING AFFIDAVIT

West Virginia Code §5A-3-10a states: No contract or renewal of any contract may be awarded by the state or any of its political subdivisions to any vendor or prospective vendor when the vendor or prospective vendor or a related party to the vendor or prospective vendor is a debtor and the debt owed is an amount greater than one thousand dollars in the aggregate.

DEFINITIONS:

"Debt" means any assessment, premium, penalty, fine, tax or other amount of money owed to the state or any of its political subdivisions because of a judgment, fine, permit violation, license assessment, defaulted workers' compensation premium, penalty or other assessment presently delinquent or due and required to be paid to the state or any of its political subdivisions, including any interest or additional penalties accrued thereon.

"Debtor" means any individual, corporation, partnership, association, limited liability company or any other form or business association owing a debt to the state or any of its political subdivisions. "Political subdivision" means any county commission; municipality; county board of education; any instrumentality established by a county or municipality; any separate corporation or instrumentality established by one or more counties or municipalities, as permitted by law; or any public body charged by law with the performance of a government function or whose jurisdiction is coextensive with one or more counties or municipalities. "Related party" means a party, whether an individual, corporation, partnership, association, limited liability company or any other form or business association or other entity whatsoever, related to any vendor by blood, marriage, ownership or contract through which the party has a relationship of ownership or other interest with the vendor so that the party will actually or by effect receive or control a portion of the benefit, profit or other consideration from performance of a vendor contract with the party receiving an amount that meets or exceed five percent of the total contract amount.

EXCEPTION: The prohibition of this section does not apply where a vendor has contested any tax administered pursuant to chapter eleven of this code, workers' compensation premium, permit fee or environmental fee or assessment and the matter has not become final or where the vendor has entered into a payment plan or agreement and the vendor is not in default of any of the provisions of such plan or agreement.

Under penalty of law for false swearing (*West Virginia Code §61-5-3*), it is hereby certified that the vendor affirms and acknowledges the information in this affidavit and is in compliance with the requirements as stated.

WITNESS THE FOLLOWING SIGNATURE

Vendor's Name: MH Equipment Co.

Authorized Signature: [Signature] Date: 5/10/10

State of West Virginia

County of Kanawha, to-wit:

Taken, subscribed, and sworn to before me this 10 day of May, 2010.

My Commission expires July 9, 2019.

AFFIX SEAL HERE

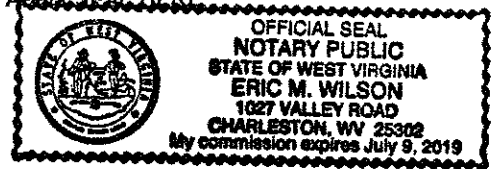

NOTARY PUBLIC [Signature]