



State of West Virginia
 Department of Administration
 Purchasing Division
 2019 Washington Street East
 Post Office Box 50130
 Charleston, WV 25305-0130

**Request for
 Quotation**

RFQ NUMBER
061000045

PAGE
1

ADDRESS CORRESPONDENCE TO ATTENTION OF
**MICHAEL AUSTIN
 304-558-2402**

***709055926 304-464-4441**
CARR CONCRETE CORPORATION
PO BOX 265

WAVERLY WV 26184-0265

DIVISION OF HIGHWAYS
JOBSITE
SEE SPECIFICATIONS

DATE PRINTED 09/16/2009	TERMS OF SALE	SHIP VIA	F.O.B.	FREIGHT TERMS
-----------------------------------	---------------	----------	--------	---------------

BID OPENING DATE: **10/07/2009** BID OPENING TIME **01:30PM**

LINE	QUANTITY	UOP	CAT NO	ITEM NUMBER	UNIT PRICE	AMOUNT
0001	1	LS		210-16	105,936.00	105,936.00
PRESTRESSED CONCRETE BEAMS WITH ACCESSORIES TO PROVIDE DEEP PRESTRESSED CONCRETE BEAMS WITH ACCESSORIES FOR STATE PROJECT S352-82-0.28 AT BUFFALO RUN BRIDGE, IN WETZEL COUNTY PER THE ATTACHED SPECIFICATIONS. PLEASE CALL 24 HOURS BEFORE ANY DELIVERY @ 304-843-4032 EXHIBIT 10 REQUISITION NO.: 061000045 ADDENDUM ACKNOWLEDGEMENT I HEREBY ACKNOWLEDGE RECEIPT OF THE FOLLOWING CHECKED ADDENDUM(S) AND HAVE MADE THE NECESSARY REVISIONS TO MY PROPOSAL, PLANS AND/OR SPECIFICATION, ETC. ADDENDUM NO.'S: NO. 1 NO. 2 NO. 3 NO. 4 NO. 5						

RECEIVED
 2009 OCT -6 A 10:13
 PURCHASING DIVISION
 STATE OF WV
RECEIVED
 SEP 18 2009

SEE REVERSE SIDE FOR TERMS AND CONDITIONS			
SIGNATURE <i>Al "Burr" Stanley</i>	TELEPHONE 304-464-4441	DATE 10/5/09	
TITLE Project Manager	FAX 55-0685425	ADDRESS CHANGES TO BE NOTED ABOVE	

WHEN RESPONDING TO RFQ, INSERT NAME AND ADDRESS IN SPACE ABOVE LABELED 'VENDOR'

**GENERAL TERMS & CONDITIONS
REQUEST FOR QUOTATION (RFQ) AND REQUEST FOR PROPOSAL (RFP)**

1. Awards will be made in the best interest of the State of West Virginia.
2. The State may accept or reject in part, or in whole, any bid.
3. All quotations are governed by the *West Virginia Code* and the *Legislative Rules* of the Purchasing Division.
4. Prior to any award, the apparent successful vendor must be properly registered with the Purchasing Division and have paid the required \$125 fee.
5. All services performed or goods delivered under State Purchase Order/Contracts are to be continued for the term of the Purchase Order/Contracts, contingent upon funds being appropriated by the Legislature or otherwise being made available. In the event funds are not appropriated or otherwise available for these services or goods, this Purchase Order/Contract becomes void and of no effect after June 30.
6. Payment may only be made after the delivery and acceptance of goods or services.
7. Interest may be paid for late payment in accordance with the *West Virginia Code*.
8. Vendor preference will be granted upon written request in accordance with the *West Virginia Code*.
9. The State of West Virginia is exempt from federal and state taxes and will not pay or reimburse such taxes.
10. The Director of Purchasing may cancel any Purchase Order/Contract upon 30 days written notice to the seller.
11. The laws of the State of West Virginia and the *Legislative Rules* of the Purchasing Division shall govern all rights and duties under the Contract, including without limitation the validity of this Purchase Order/Contract.
12. Any reference to automatic renewal is hereby deleted. The Contract may be renewed only upon mutual written agreement of the parties.
13. **BANKRUPTCY:** In the event the vendor/contractor files for bankruptcy protection, the State may deem this contract null and void, and terminate such contract without further order.
14. **HIPAA BUSINESS ASSOCIATE ADDENDUM:** The West Virginia State Government HIPAA Business Associate Addendum (BAA), approved by the Attorney General, and available online at the Purchasing Division's web site (<http://www.state.wv.us/admin/purchase/vrc/hipaa.htm>) is hereby made part of the agreement. Provided that, the Agency meets the definition of a Cover Entity (45 CFR §160.103) and will be disclosing Protected Health Information (45 CFR §160.103) to the vendor.
15. **WEST VIRGINIA ALCOHOL & DRUG-FREE WORKPLACE ACT:** If this Contract constitutes a public improvement construction contract as set forth in Article 1D, Chapter 21 of the West Virginia Code ("The West Virginia Alcohol and Drug-Free Workplace Act"), then the following language shall hereby become part of this Contract: "The contractor and its subcontractors shall implement and maintain a written drug-free workplace policy in compliance with the West Virginia Alcohol and Drug-Free Workplace Act, as set forth in Article 1D, Chapter 21 of the West Virginia Code. The contractor and its subcontractors shall provide a sworn statement in writing, under the penalties of perjury, that they maintain a valid drug-free workplace policy in compliance with the West Virginia and Drug-Free Workplace Act. It is understood and agreed that this Contract shall be cancelled by the awarding authority if the Contractor: 1) Fails to implement its drug-free workplace policy; 2) Fails to provide information regarding implementation of the contractor's drug-free workplace policy at the request of the public authority; or 3) Provides to the public authority false information regarding the contractor's drug-free workplace policy."

INSTRUCTIONS TO BIDDERS

1. Use the quotation forms provided by the Purchasing Division.
2. **SPECIFICATIONS:** Items offered must be in compliance with the specifications. Any deviation from the specifications must be clearly indicated by the bidder. Alternates offered by the bidder as **EQUAL** to the specifications must be clearly defined. A bidder offering an alternate should attach complete specifications and literature to the bid. The Purchasing Division may waive minor deviations to specifications.
3. Complete all sections of the quotation form.
4. Unit prices shall prevail in case of discrepancy.
5. All quotations are considered F.O.B. destination unless alternate shipping terms are clearly identified in the quotation.
6. **BID SUBMISSION:** All quotations must be delivered by the bidder to the office listed below prior to the date and time of the bid opening. Failure of the bidder to deliver the quotations on time will result in bid disqualifications: Department of Administration, Purchasing Division, 2019 Washington Street East, P.O. Box 50130, Charleston, WV 25305-0130



State of West Virginia
 Department of Administration
 Purchasing Division
 2019 Washington Street East
 Post Office Box 50130
 Charleston, WV 25305-0130

Request for Quotation

RFQ NUMBER
061000045

PAGE
2

ADDRESS CORRESPONDENCE TO ATTENTION OF
MICHAEL AUSTIN
304-558-2402

VENDOR

*709055926 304-464-4441
 CARR CONCRETE CORPORATION
 PO BOX 265
 WAVERLY WV 26184-0265

SHIP TO

DIVISION OF HIGHWAYS
 JOBSITE
 SEE SPECIFICATIONS

DATE PRINTED	TERMS OF SALE	SHIP VIA	F.O.B.	FREIGHT TERMS
09/16/2009				

BID OPENING DATE: 10/07/2009 BID OPENING TIME 01:30PM

LINE	QUANTITY	UOP	CAT NO	ITEM NUMBER	UNIT PRICE	AMOUNT
------	----------	-----	--------	-------------	------------	--------

I UNDERSTAND THAT FAILURE TO CONFIRM THE RECEIPT OF THE ADDENDUM(S) MAY BE CAUSE FOR REJECTION OF BIDS.

VENDOR MUST CLEARLY UNDERSTAND THAT ANY VERBAL REPRESENTATION MADE OR ASSUMED TO BE MADE DURING ANY ORAL DISCUSSION HELD BETWEEN VENDOR'S REPRESENTATIVES AND ANY STATE PERSONNEL IS NOT BINDING. ONLY THE INFORMATION ISSUED IN WRITING AND ADDED TO THE SPECIFICATIONS BY AN OFFICIAL ADDENDUM IS BINDING.

RE "Burr" Stearns

 SIGNATURE

Carr Concrete Corp.

 COMPANY

10/2/09

 DATE

REV. 11/96

NOTICE

A SIGNED BID MUST BE SUBMITTED TO:

DEPARTMENT OF ADMINISTRATION
 PURCHASING DIVISION
 BUILDING 15
 2019 WASHINGTON STREET, EAST
 CHARLESTON, WV 25305-0130

THE BID SHOULD CONTAIN THIS INFORMATION ON THE FACE OF

SEE REVERSE SIDE FOR TERMS AND CONDITIONS

SIGNATURE	TELEPHONE	DATE
TITLE	FEIN	ADDRESS CHANGES TO BE NOTED ABOVE

WHEN RESPONDING TO RFQ, INSERT NAME AND ADDRESS IN SPACE ABOVE LABELED 'VENDOR'



State of West Virginia
 Department of Administration
 Purchasing Division
 2019 Washington Street East
 Post Office Box 50130
 Charleston, WV 25305-0130

Request for Quotation

RFQ NUMBER
 061000045

PAGE
 3

ADDRESS CORRESPONDENCE TO ATTENTION OF:
 MICHAEL AUSTIN
 304-558-2402

VENDOR

*709055926 304-464-4441
 CARR CONCRETE CORPORATION
 PO BOX 265
 WAVERLY WV 26184-0265

SHIP TO

DIVISION OF HIGHWAYS
 JOBSITE
 SEE SPECIFICATIONS

DATE PRINTED 09/16/2009	TERMS OF SALE	SHIP VIA	F.O.B.	FREIGHT TERMS
----------------------------	---------------	----------	--------	---------------

BID OPENING DATE: 10/07/2009 BID OPENING TIME 01:30PM

LINE	QUANTITY	UQP	CAT NO	ITEM NUMBER	UNIT PRICE	AMOUNT
THE ENVELOPE OR THE BID MAY NOT BE CONSIDERED: SEALED BID BUYER: 33 RFQ. NO.: 061000045 BID OPENING DATE: 10/7/09 BID OPENING TIME: 1:30 pm PLEASE PROVIDE A FAX NUMBER IN CASE IT IS NECESSARY TO CONTACT YOU REGARDING YOUR BID: 304-464-4013 CONTACT PERSON (PLEASE PRINT CLEARLY): Burr Stanley ***** THIS IS THE END OF RFQ 061000045 ***** TOTAL: \$105,936.00						

SEE REVERSE SIDE FOR TERMS AND CONDITIONS

SIGNATURE	TELEPHONE	DATE
TITLE	FEIN	ADDRESS CHANGES TO BE NOTED ABOVE

WHEN RESPONDING TO RFQ, INSERT NAME AND ADDRESS IN SPACE ABOVE LABELED 'VENDOR'

1. DESCRIPTION

The beams shall be 33" deep X 36" wide X 67'-6" long.

Two (2) exterior beams and seven (7) interior beams are required.

In addition to the beams the fabricator shall also supply in accordance with the attached plans all associated items included but not limited to the following.

Guardrail Posts and Hardware attached to the exterior beams; Bearing Pads; Anchor Dowels; Post Tensioning Bars with Nuts and Bearing Plates and 2 extra nuts; Sponge Rubber Joint Filler, Washers, and Grout Stop.

2. ACCEPTANCE

Cracks developing in a beam may be cause for rejection of the beam. Cracks that are not detrimental to the structural integrity of the beam, as determined by the Division of Highways, may be accepted under the following conditions:

- 1) Cracks of 0.004 inch or less shall be treated with a second coat of a Division of Highways approved concrete sealer.
- 2) Cracks of greater than 0.004 inch shall be treated by a Division of Highways approved epoxy injection methods. All concrete sealer and epoxy injection required for acceptance shall be performed at no additional cost to the Division of Highways.

3. DELIVERY

ALL BEAMS AND ACCESSORIES SHALL BE DELIVERED TO THE PROJECT SITE DURING THE WEEK OF APRIL 13, 2010.

Upon receipt of a Purchase Order the Vendor shall submit shop drawings to the District Bridge Engineer within fifteen (15) calendar days. Shop drawings must be approved by the Division of Highways prior to the manufacture of any beam sections.

Should the Vendor fail to meet the above delivery schedule, liquidated damages will be assessed in accordance with Section 108.7 of the current Division of Highways Standard Specifications Roads and Bridges.

Sites for delivery of beam sections and accessories under this contract shall be accessible to equipment that is normally and customarily used for transportation of beam sections. Delivery will not be required where gross vehicle loaded weights will exceed the legal road or bridge load. Upon receipt of an approved Purchase Order, the Vendor must notify the District Bridge Engineer within ten (10) calendar days if delivery under the terms of this contract cannot be performed due to weight restrictions or roadway geometrics.

Prior to delivery, all Beams, Accessories and Optional Items shall be tested and accepted in accordance with Section 603 of the Division of Highways Standard Specifications Roads and Bridges adopted 1993, as modified by the July 1, 1998 Supplemental Specifications.

4. PARTIAL PAYMENT OF APPROVED BEAMS

Upon completion of manufacture and approval by the Division of Highways of all beams specified on Purchase Order, the vendor may invoice and the Division will pay for the cost of manufacturing the beams, not to exceed 65% of the total cost of the delivered beams. Partial payment for the beams shall be subject to the following conditions:

- a. The vendor must request partial payment and furnish an official invoice for the manufactured and approved beams.
- b. The partial payment invoice shall be accompanied by a surety bond equal to the invoiced amount guaranteeing delivery of all items specified on the Purchase Order.
- c. The vendor shall furnish a statement of approved beams condition and exact storage location.
- d. The vendor shall furnish a legal right-of-entry onto the storage site to Division of Highways' employees and/or agents for the purpose of inspecting, sampling, testing and removing any or all Beams.
- e. The vendor shall certify that the stored beams are suitably marked and identified as property of the Division of Highways and will not be for any purpose not designated by the Division.

FEDERAL PROJECT NUMBER	STATE DISTRICT	COUNTY	SHEET NUMBER
85547-229	14	Warren	7

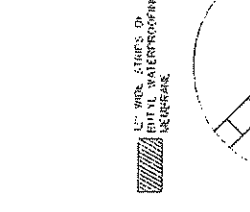
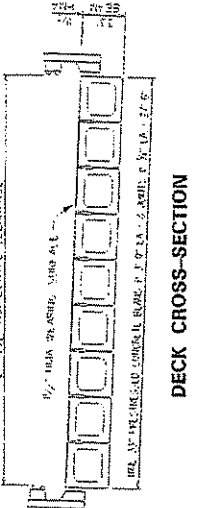
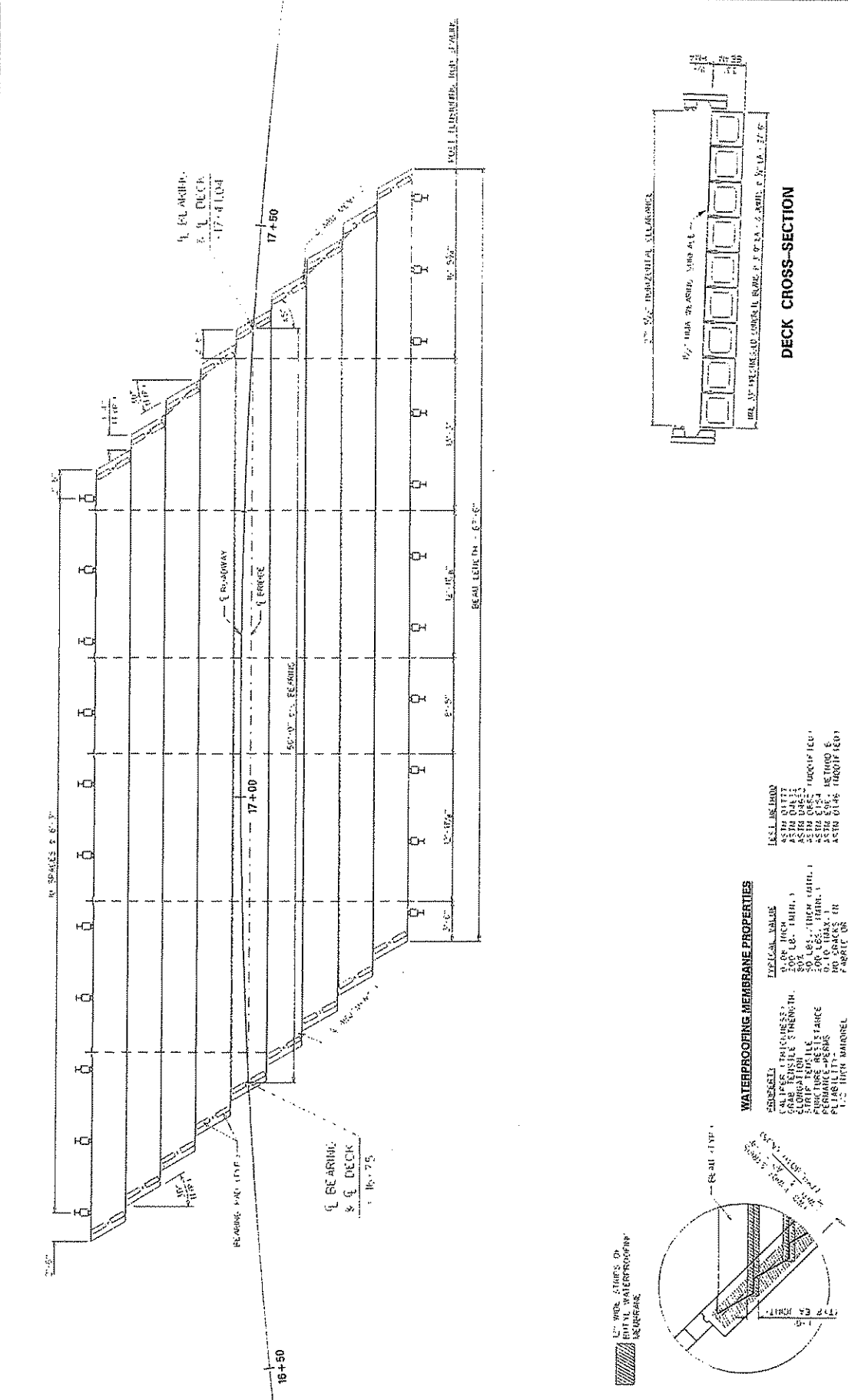

- WATERPROOFING MEMBRANE PROPERTIES
- CONCRETE: 4000 PSI
 - STEEL: A36
 - WELDS: E70
 - CLASSTIFICATION: A
 - CORROSION RESISTANCE: 100% (100% MIN.)
 - FULL THICKNESS
 - PERFORMANCE: 25 YEARS
 - PLIABILITY: 100%
 - 180 DEGREE BEND AT 100% STRETCH

- LIST OF BRANDS
- ASTM D-1177
 - ASTM D-1178
 - ASTM D-1179
 - ASTM D-1180
 - ASTM D-1181
 - ASTM D-1182
 - ASTM D-1183
 - ASTM D-1184
 - ASTM D-1185
 - ASTM D-1186
 - ASTM D-1187
 - ASTM D-1188
 - ASTM D-1189
 - ASTM D-1190
 - ASTM D-1191
 - ASTM D-1192
 - ASTM D-1193
 - ASTM D-1194
 - ASTM D-1195
 - ASTM D-1196
 - ASTM D-1197
 - ASTM D-1198
 - ASTM D-1199
 - ASTM D-1200
 - ASTM D-1201
 - ASTM D-1202
 - ASTM D-1203
 - ASTM D-1204
 - ASTM D-1205
 - ASTM D-1206
 - ASTM D-1207
 - ASTM D-1208
 - ASTM D-1209
 - ASTM D-1210
 - ASTM D-1211
 - ASTM D-1212
 - ASTM D-1213
 - ASTM D-1214
 - ASTM D-1215
 - ASTM D-1216
 - ASTM D-1217
 - ASTM D-1218
 - ASTM D-1219
 - ASTM D-1220
 - ASTM D-1221
 - ASTM D-1222
 - ASTM D-1223
 - ASTM D-1224
 - ASTM D-1225
 - ASTM D-1226
 - ASTM D-1227
 - ASTM D-1228
 - ASTM D-1229
 - ASTM D-1230
 - ASTM D-1231
 - ASTM D-1232
 - ASTM D-1233
 - ASTM D-1234
 - ASTM D-1235
 - ASTM D-1236
 - ASTM D-1237
 - ASTM D-1238
 - ASTM D-1239
 - ASTM D-1240
 - ASTM D-1241
 - ASTM D-1242
 - ASTM D-1243
 - ASTM D-1244
 - ASTM D-1245
 - ASTM D-1246
 - ASTM D-1247
 - ASTM D-1248
 - ASTM D-1249
 - ASTM D-1250
 - ASTM D-1251
 - ASTM D-1252
 - ASTM D-1253
 - ASTM D-1254
 - ASTM D-1255
 - ASTM D-1256
 - ASTM D-1257
 - ASTM D-1258
 - ASTM D-1259
 - ASTM D-1260
 - ASTM D-1261
 - ASTM D-1262
 - ASTM D-1263
 - ASTM D-1264
 - ASTM D-1265
 - ASTM D-1266
 - ASTM D-1267
 - ASTM D-1268
 - ASTM D-1269
 - ASTM D-1270
 - ASTM D-1271
 - ASTM D-1272
 - ASTM D-1273
 - ASTM D-1274
 - ASTM D-1275
 - ASTM D-1276
 - ASTM D-1277
 - ASTM D-1278
 - ASTM D-1279
 - ASTM D-1280
 - ASTM D-1281
 - ASTM D-1282
 - ASTM D-1283
 - ASTM D-1284
 - ASTM D-1285
 - ASTM D-1286
 - ASTM D-1287
 - ASTM D-1288
 - ASTM D-1289
 - ASTM D-1290
 - ASTM D-1291
 - ASTM D-1292
 - ASTM D-1293
 - ASTM D-1294
 - ASTM D-1295
 - ASTM D-1296
 - ASTM D-1297
 - ASTM D-1298
 - ASTM D-1299
 - ASTM D-1300

SCALE 1"=20'

THE WEST VIRGINIA DEPARTMENT OF TRANSPORTATION
DIVISION OF HIGHWAYS

PROJECT NO. 85547-229
SHEET NO. 7 OF 24

DECK DETAILS
BUFFALO RIVER BRIDGE

DATE: 10/15/54
BY: [Signature]

PROJECT NO.	155-202	DATE	12/1/92
SHEET NO.	17	TOTAL SHEETS	20

GENERAL NOTES:

- THE CONTRACTOR SHALL BE RESPONSIBLE FOR THE DESIGN AND CONSTRUCTION OF ALL STRUCTURAL PROVISIONS OF SECTION 202 OF THE STANDARD SPECIFICATIONS FOR HIGHWAYS.
- THE CONTRACTOR SHALL BE RESPONSIBLE FOR THE DESIGN AND CONSTRUCTION OF ALL STRUCTURAL PROVISIONS OF SECTION 202 OF THE STANDARD SPECIFICATIONS FOR HIGHWAYS.
- THE CONTRACTOR SHALL BE RESPONSIBLE FOR THE DESIGN AND CONSTRUCTION OF ALL STRUCTURAL PROVISIONS OF SECTION 202 OF THE STANDARD SPECIFICATIONS FOR HIGHWAYS.

MATERIALS & FABRICATION NOTES:

- ALL STEEL FABRICATED BY THE CONTRACTOR SHALL BE IN ACCORDANCE WITH THE ASTM A992 SPECIFICATION FOR STRUCTURAL STEEL.
- ALL STEEL FABRICATED BY THE CONTRACTOR SHALL BE IN ACCORDANCE WITH THE ASTM A992 SPECIFICATION FOR STRUCTURAL STEEL.
- ALL STEEL FABRICATED BY THE CONTRACTOR SHALL BE IN ACCORDANCE WITH THE ASTM A992 SPECIFICATION FOR STRUCTURAL STEEL.

CONCRETE NOTES:

- CONCRETE SHALL BE PLACED AND COMPACTED IN ACCORDANCE WITH SECTION 207 OF THE STANDARD SPECIFICATIONS FOR HIGHWAYS.
- CONCRETE SHALL BE PLACED AND COMPACTED IN ACCORDANCE WITH SECTION 207 OF THE STANDARD SPECIFICATIONS FOR HIGHWAYS.
- CONCRETE SHALL BE PLACED AND COMPACTED IN ACCORDANCE WITH SECTION 207 OF THE STANDARD SPECIFICATIONS FOR HIGHWAYS.

WEST VIRGINIA DEPARTMENT OF TRANSPORTATION	
DIVISION OF HIGHWAYS	
ENGINEERING DIVISION	
BUFFALO RUN BRIDGE	
DESIGN & ASSEMBLY NOTES	STANDARD SPEC BR-100

GENERAL NOTES:

- THE CONTRACTOR SHALL BE RESPONSIBLE FOR THE DESIGN AND CONSTRUCTION OF ALL STRUCTURAL PROVISIONS OF SECTION 202 OF THE STANDARD SPECIFICATIONS FOR HIGHWAYS.
- THE CONTRACTOR SHALL BE RESPONSIBLE FOR THE DESIGN AND CONSTRUCTION OF ALL STRUCTURAL PROVISIONS OF SECTION 202 OF THE STANDARD SPECIFICATIONS FOR HIGHWAYS.
- THE CONTRACTOR SHALL BE RESPONSIBLE FOR THE DESIGN AND CONSTRUCTION OF ALL STRUCTURAL PROVISIONS OF SECTION 202 OF THE STANDARD SPECIFICATIONS FOR HIGHWAYS.

MATERIALS & FABRICATION NOTES:

- ALL STEEL FABRICATED BY THE CONTRACTOR SHALL BE IN ACCORDANCE WITH THE ASTM A992 SPECIFICATION FOR STRUCTURAL STEEL.
- ALL STEEL FABRICATED BY THE CONTRACTOR SHALL BE IN ACCORDANCE WITH THE ASTM A992 SPECIFICATION FOR STRUCTURAL STEEL.
- ALL STEEL FABRICATED BY THE CONTRACTOR SHALL BE IN ACCORDANCE WITH THE ASTM A992 SPECIFICATION FOR STRUCTURAL STEEL.

CONCRETE NOTES:

- CONCRETE SHALL BE PLACED AND COMPACTED IN ACCORDANCE WITH SECTION 207 OF THE STANDARD SPECIFICATIONS FOR HIGHWAYS.
- CONCRETE SHALL BE PLACED AND COMPACTED IN ACCORDANCE WITH SECTION 207 OF THE STANDARD SPECIFICATIONS FOR HIGHWAYS.
- CONCRETE SHALL BE PLACED AND COMPACTED IN ACCORDANCE WITH SECTION 207 OF THE STANDARD SPECIFICATIONS FOR HIGHWAYS.

WEST VIRGINIA DEPARTMENT OF TRANSPORTATION	
DIVISION OF HIGHWAYS	
ENGINEERING DIVISION	
BUFFALO RUN BRIDGE	
DESIGN & ASSEMBLY NOTES	STANDARD SPEC BR-100

GENERAL NOTES:

- THE CONTRACTOR SHALL BE RESPONSIBLE FOR THE DESIGN AND CONSTRUCTION OF ALL STRUCTURAL PROVISIONS OF SECTION 202 OF THE STANDARD SPECIFICATIONS FOR HIGHWAYS.
- THE CONTRACTOR SHALL BE RESPONSIBLE FOR THE DESIGN AND CONSTRUCTION OF ALL STRUCTURAL PROVISIONS OF SECTION 202 OF THE STANDARD SPECIFICATIONS FOR HIGHWAYS.
- THE CONTRACTOR SHALL BE RESPONSIBLE FOR THE DESIGN AND CONSTRUCTION OF ALL STRUCTURAL PROVISIONS OF SECTION 202 OF THE STANDARD SPECIFICATIONS FOR HIGHWAYS.

MATERIALS & FABRICATION NOTES:

- ALL STEEL FABRICATED BY THE CONTRACTOR SHALL BE IN ACCORDANCE WITH THE ASTM A992 SPECIFICATION FOR STRUCTURAL STEEL.
- ALL STEEL FABRICATED BY THE CONTRACTOR SHALL BE IN ACCORDANCE WITH THE ASTM A992 SPECIFICATION FOR STRUCTURAL STEEL.
- ALL STEEL FABRICATED BY THE CONTRACTOR SHALL BE IN ACCORDANCE WITH THE ASTM A992 SPECIFICATION FOR STRUCTURAL STEEL.

CONCRETE NOTES:

- CONCRETE SHALL BE PLACED AND COMPACTED IN ACCORDANCE WITH SECTION 207 OF THE STANDARD SPECIFICATIONS FOR HIGHWAYS.
- CONCRETE SHALL BE PLACED AND COMPACTED IN ACCORDANCE WITH SECTION 207 OF THE STANDARD SPECIFICATIONS FOR HIGHWAYS.
- CONCRETE SHALL BE PLACED AND COMPACTED IN ACCORDANCE WITH SECTION 207 OF THE STANDARD SPECIFICATIONS FOR HIGHWAYS.

WEST VIRGINIA DEPARTMENT OF TRANSPORTATION	
DIVISION OF HIGHWAYS	
ENGINEERING DIVISION	
BUFFALO RUN BRIDGE	
DESIGN & ASSEMBLY NOTES	STANDARD SPEC BR-100

ITEM NO.	DESCRIPTION	UNIT	QUANTITY
1	PRESTRESSED CONCRETE BEAM	LF	100
2	CONCRETE CURB	LF	100
3	CONCRETE GUARDRAIL	LF	100
4	REINFORCING STEEL	LB	10000
5	FORMWORK	SQ YD	500
6	PAINT	SQ YD	100
7	GRASS SEED	SQ YD	100
8	ROCK	CY	100
9	GRADATION	SQ YD	100
10	ASPHALT	SQ YD	100

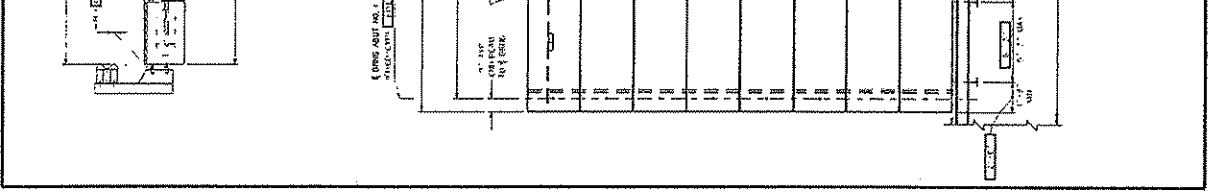
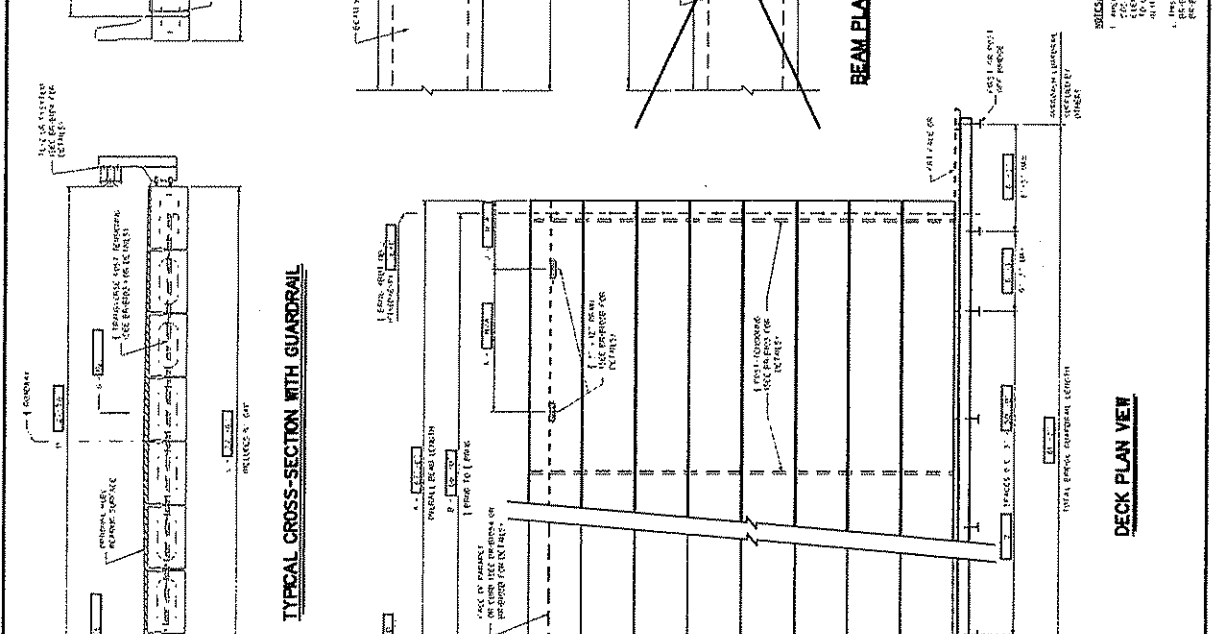
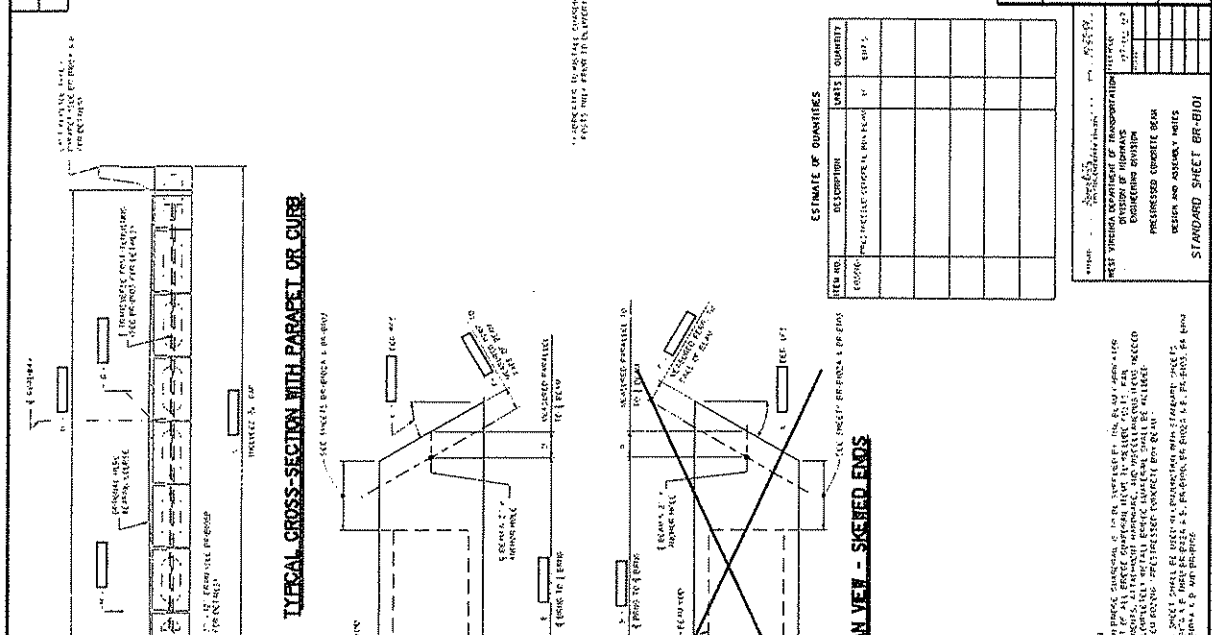

WEST VIRGINIA DEPARTMENT OF TRANSPORTATION
DIVISION OF HIGHWAYS
ENGINEERING DIVISION

BUFFALO RUN BRIDGE

PRESTRESSED CONCRETE BEAM
DESIGN & ASSEMBLY NOTES

ESTIMATE OF QUANTITIES

ITEM NO.	DESCRIPTION	UNIT	QUANTITY
1	PRESTRESSED CONCRETE BEAM	LF	100
2	CONCRETE CURB	LF	100
3	CONCRETE GUARDRAIL	LF	100
4	REINFORCING STEEL	LB	10000
5	FORMWORK	SQ YD	500
6	PAINT	SQ YD	100
7	GRASS SEED	SQ YD	100
8	ROCK	CY	100
9	GRADATION	SQ YD	100
10	ASPHALT	SQ YD	100

STANDARD SHEET BR-B101

DESIGN AND ASSEMBLY NOTES

1. ALL DIMENSIONS ARE IN FEET AND INCHES UNLESS OTHERWISE SPECIFIED.

2. ALL REINFORCING STEEL SHALL BE ASTM A615 GRADE 60.

3. ALL CONCRETE SHALL BE ASTM C150 TYPE 1.

4. ALL FORMWORK SHALL BE 1/2" THICK PLYWOOD ON 4" X 4" POSTS.

5. ALL JOINTS SHALL BE REINFORCED WITH 2# BARS.

6. ALL SURFACES SHALL BE FINISHED TO A SMOOTH, EVEN SURFACE.

7. ALL DIMENSIONS ARE TO FACE UNLESS OTHERWISE SPECIFIED.

WEST VIRGINIA DEPARTMENT OF TRANSPORTATION
DIVISION OF HIGHWAYS
ENGINEERING DIVISION

BUFFALO RUN BRIDGE

PRESTRESSED CONCRETE BEAM
DESIGN & ASSEMBLY NOTES

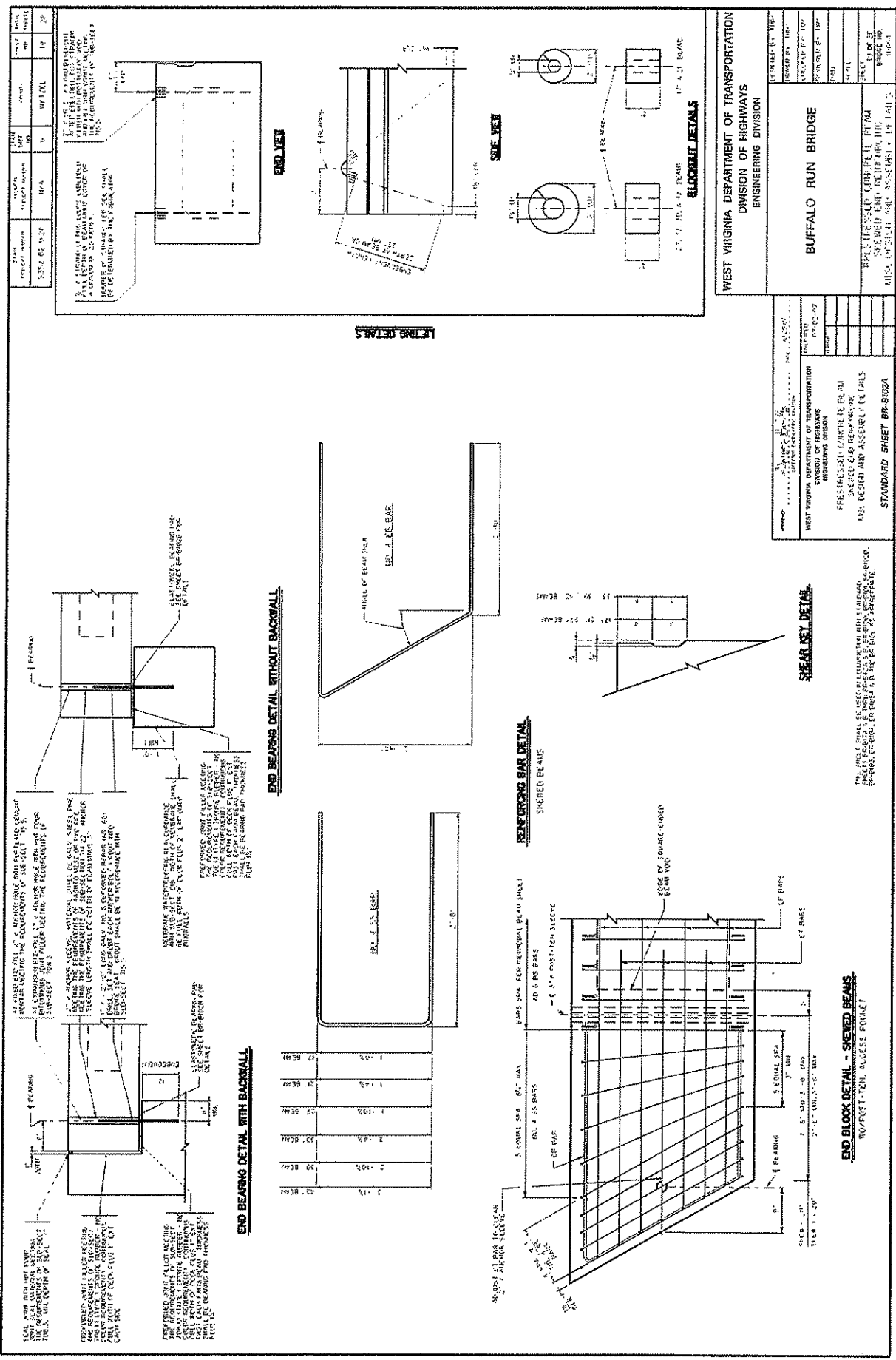

WEST VIRGINIA DEPARTMENT OF TRANSPORTATION
 DIVISION OF HIGHWAYS
 ENGINEERING DIVISION

BUFFALO RUN BRIDGE

DESIGNED BY: [Name]
 CHECKED BY: [Name]
 APPROVED BY: [Name]

STANDARD SHEET BR-802A

TITLE PRESTRESSING BEAMS BRIDGE NO. 10-2 SHEET NO. 201-211	DIVISION HIGHWAYS PROJECT NO. 10-2	DATE 10-1-54	DRAWN BY J. W. L.	CHECKED BY J. W. L.	SCALE AS SHOWN
---	--	-----------------	----------------------	------------------------	-------------------

ANCHOR SLEEVE DETAIL

ANCHOR SLEEVE DETAIL

DEP. GROOVE DETAIL

DEP. GROOVE DETAIL

PLAN VIEW - BEARING PLACEMENT

PLAN VIEW - BEARING PLACEMENT

SIDE ELEVATION DETAIL

SIDE ELEVATION DETAIL

SECTION A-A

SECTION A-A

SECTION A-A

SECTION A-A

SECTION A-A

SECTION A-A

SECTION A-A

SECTION A-A

SECTION A-A

SECTION A-A

SECTION A-A

SECTION A-A

WEST VIRGINIA DEPARTMENT OF TRANSPORTATION
DIVISION OF HIGHWAYS
ENGINEERING DIVISION

BUFFALO RUN BRIDGE

PRESTRESSED CONCRETE BEAM
ELASTOMERIC BEARING PAD DETAILS
MISC. DESIGN AND ASSEMBLY DETAILS

WEST VIRGINIA DEPARTMENT OF TRANSPORTATION DIVISION OF HIGHWAYS ENGINEERING DIVISION PROJECT NO. 10-2 SHEET NO. 201-211	WEST VIRGINIA DEPARTMENT OF TRANSPORTATION DIVISION OF HIGHWAYS ENGINEERING DIVISION PROJECT NO. 10-2 SHEET NO. 201-211
---	---

NOTES:

- ELASTOMERIC BEARING PADS ARE DESIGNED IN ACCORDANCE WITH DESIGN SECTION 1010.8 CONTAINED IN SECTION 14 OF THE ASHTO LUGS BRIDGE DESIGN SPECIFICATIONS. FABRICATOR SHALL BE IN ACCORDANCE WITH SECTION 10 OF THE ASHTO LUGS BRIDGE CONSTRUCTION SPECIFICATIONS.
- ALL BEARINGS ARE DESIGNED FOR A LOW TEMPERATURE JOINT C AND SHALL HAVE A DIAPHRAGM STRENGTH OF 80. THE PADS AND FABRICATOR SHALL HAVE A MINIMUM YIELD STRENGTH OF 50 KSI. PADS SHALL BE SECURED TO THE BEAMS WITH ANCHOR BOLTS. FABRICATOR SHALL FURNISH BEVELED SOLE PLATES AS SHOWN.
- DESIGNER, FABRICATOR AND ERECTOR SHALL BE AWARE THAT WELDED END BEAMS MAY TWIST OR WARP, CAUSING UNEVEN BEAM SEATING AT THE BEARINGS. THE CONTRACTOR IS REQUESTED TO CHECK THE BEAM SEATING AT THE BEARINGS AFTER THE BEAMS ARE PLACED ON THE BEARINGS. AFTER CORRECTION SHALL BE MADE, THE FABRICATOR SHALL FURNISH BEVELED SOLE PLATES AS SHOWN. IF CORRECTIONS ARE REQUIRED PRIOR TO SHIPMENT.
- FOR BEAMS WITH STEPPED ENDS USE PADS A2, B2, W2 OR C2 ON BOTH SIDES OF EACH BEAM.
- ELASTOMERIC BEARING PADS SHALL BE INCLUDED IN THE PRICE OF THE BEAMS.
- THIS SHEET SHALL BE USED IN CONNECTION WITH STANDARD SHEETS BR-102A & B, BR-102B & C, BR-102D & E, BR-102F & G, BR-102H & I, BR-102J & K, BR-102L & M, BR-102N & O, BR-102P & Q, BR-102R & S, BR-102T & U, BR-102V & W, BR-102X & Y, BR-102Z & AA, BR-102AB & AC, BR-102AD & AE, BR-102AF & AG, BR-102AH & AI, BR-102AJ & AK, BR-102AL & AM, BR-102AN & AO, BR-102AP & AQ, BR-102AR & AS, BR-102AT & AU, BR-102AV & AW, BR-102AX & AY, BR-102AZ & BA, BR-102BB & BC, BR-102BD & BE, BR-102BF & BG, BR-102BH & BI, BR-102BJ & BK, BR-102BL & BM, BR-102BN & BO, BR-102BP & BQ, BR-102BR & BS, BR-102BT & BU, BR-102BV & BW, BR-102BX & BY, BR-102BZ & CA, CB, CC, CD, CE, CF, CG, CH, CI, CJ, CK, CL, CM, CN, CO, CP, CQ, CR, CS, CT, CU, CV, CW, CX, CY, CZ, DA, DB, DC, DD, DE, DF, DG, DH, DI, DJ, DK, DL, DM, DN, DO, DP, DQ, DR, DS, DT, DU, DV, DW, DX, DY, DZ, EA, EB, EC, ED, EE, EF, EG, EH, EI, EJ, EK, EL, EM, EN, EO, EP, EQ, ER, ES, ET, EU, EV, EW, EX, EY, EZ, FA, FB, FC, FD, FE, FF, FG, FH, FI, FJ, FK, FL, FM, FN, FO, FP, FQ, FR, FS, FT, FU, FV, FW, FX, FY, FZ, GA, GB, GC, GD, GE, GF, GG, GH, GI, GJ, GK, GL, GM, GN, GO, GP, GQ, GR, GS, GT, GU, GV, GW, GX, GY, GZ, HA, HB, HC, HD, HE, HF, HG, HH, HI, HJ, HK, HL, HM, HN, HO, HP, HQ, HR, HS, HT, HU, HV, HW, HX, HY, HZ, IA, IB, IC, ID, IE, IF, IG, IH, II, IJ, IK, IL, IM, IN, IO, IP, IQ, IR, IS, IT, IU, IV, IW, IX, IY, IZ, JA, JB, JC, JD, JE, JF, JG, JH, JI, JJ, JK, JL, JM, JN, JO, JP, JQ, JR, JS, JT, JU, JV, JW, JX, JY, JZ, KA, KB, KC, KD, KE, KF, KG, KH, KI, KJ, KK, KL, KM, KN, KO, KP, KQ, KR, KS, KT, KU, KV, KW, KX, KY, KZ, LA, LB, LC, LD, LE, LF, LG, LH, LI, LJ, LK, LL, LM, LN, LO, LP, LQ, LR, LS, LT, LU, LV, LW, LX, LY, LZ, MA, MB, MC, MD, ME, MF, MG, MH, MI, MJ, MK, ML, MM, MN, MO, MP, MQ, MR, MS, MT, MU, MV, MW, MX, MY, MZ, NA, NB, NC, ND, NE, NF, NG, NH, NI, NJ, NK, NL, NM, NN, NO, NP, NQ, NR, NS, NT, NU, NV, NW, NX, NY, NZ, OA, OB, OC, OD, OE, OF, OG, OH, OI, OJ, OK, OL, OM, ON, OO, OP, OQ, OR, OS, OT, OU, OV, OW, OX, OY, OZ, PA, PB, PC, PD, PE, PF, PG, PH, PI, PJ, PK, PL, PM, PN, PO, PP, PQ, PR, PS, PT, PU, PV, PW, PX, PY, PZ, QA, QB, QC, QD, QE, QF, QG, QH, QI, QJ, QK, QL, QM, QN, QO, QP, QQ, QR, QS, QT, QU, QV, QW, QX, QY, QZ, RA, RB, RC, RD, RE, RF, RG, RH, RI, RJ, RK, RL, RM, RN, RO, RP, RQ, RR, RS, RT, RU, RV, RW, RX, RY, RZ, SA, SB, SC, SD, SE, SF, SG, SH, SI, SJ, SK, SL, SM, SN, SO, SP, SQ, SR, SS, ST, SU, SV, SW, SX, SY, SZ, TA, TB, TC, TD, TE, TF, TG, TH, TI, TJ, TK, TL, TM, TN, TO, TP, TQ, TR, TS, TT, TU, TV, TW, TX, TY, TZ, UA, UB, UC, UD, UE, UF, UG, UH, UI, UJ, UK, UL, UM, UN, UO, UP, UQ, UR, US, UT, UY, UZ, VA, VB, VC, VD, VE, VF, VG, VH, VI, VJ, VK, VL, VM, VN, VO, VP, VQ, VR, VS, VT, VU, VV, VW, VX, VY, VZ, WA, WB, WC, WD, WE, WF, WG, WH, WI, WJ, WK, WL, WM, WN, WO, WP, WQ, WR, WS, WT, WU, WV, WW, WX, WY, WZ, XA, XB, XC, XD, XE, XF, XG, XH, XI, XJ, XK, XL, XM, XN, XO, XP, XQ, XR, XS, XT, XU, XV, XW, XX, XY, XZ, YA, YB, YC, YD, YE, YF, YG, YH, YI, YJ, YK, YL, YM, YN, YO, YP, YQ, YR, YS, YT, YU, YV, YW, YX, YZ, ZA, ZB, ZC, ZD, ZE, ZF, ZG, ZH, ZI, ZJ, ZK, ZL, ZM, ZN, ZO, ZP, ZQ, ZR, ZS, ZT, ZU, ZV, ZW, ZX, ZY, ZZ.

BOX BEAM BEARING PAD CONTROL DIMENSIONS			
PAD	WIDTH	HEIGHT	DEPTH
A1	10"	10"	10"
B1	10"	10"	10"
C1	10"	10"	10"
D1	10"	10"	10"
E1	10"	10"	10"
F1	10"	10"	10"
G1	10"	10"	10"
H1	10"	10"	10"
I1	10"	10"	10"
J1	10"	10"	10"
K1	10"	10"	10"
L1	10"	10"	10"
M1	10"	10"	10"
N1	10"	10"	10"
O1	10"	10"	10"
P1	10"	10"	10"
Q1	10"	10"	10"
R1	10"	10"	10"
S1	10"	10"	10"
T1	10"	10"	10"
U1	10"	10"	10"
V1	10"	10"	10"
W1	10"	10"	10"
X1	10"	10"	10"
Y1	10"	10"	10"
Z1	10"	10"	10"

DATE	DESCRIPTION	BY	CHKD
1954-05-25	REVISED TO SHOW REVISIONS	W. J. BROWN	W. J. BROWN
1954-05-25	REVISED TO SHOW REVISIONS	W. J. BROWN	W. J. BROWN

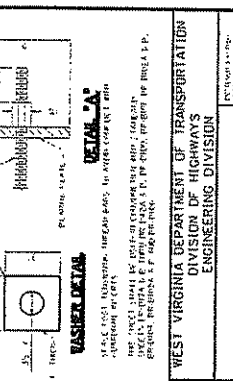
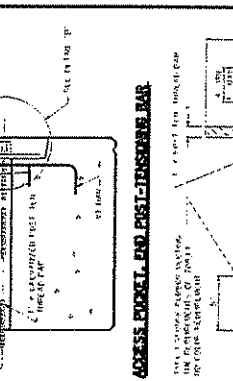
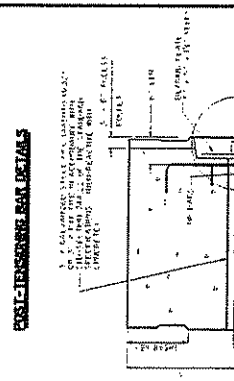
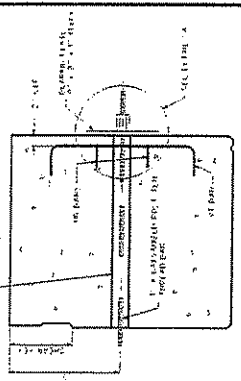

PROJECT NO.	104	DATE	05 17 54
PROJECT NAME	WEST VIRGINIA DEPARTMENT OF TRANSPORTATION DIVISION OF HIGHWAYS ENGINEERING DIVISION		
PROJECT LOCATION	BUFFALO RUN BRIDGE		
PROJECT DRAWN BY	W. J. BROWN		
PROJECT CHECKED BY	W. J. BROWN		
PROJECT DATE	MAY 17 1954		
PROJECT SHEET NO.	STANDARD SHEET BR-1013		

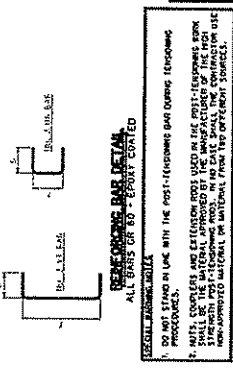
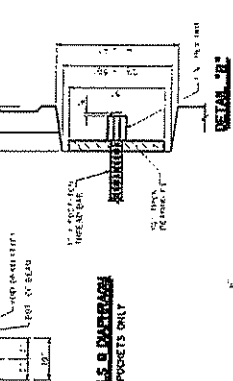
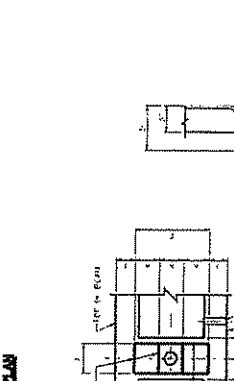
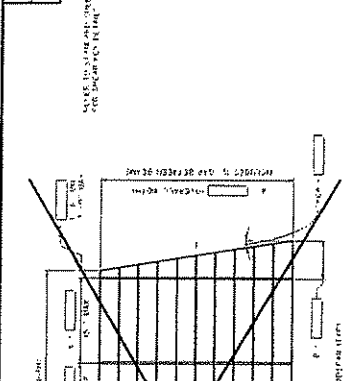

PROJECT NO.	104	DATE	05 17 54
PROJECT NAME	WEST VIRGINIA DEPARTMENT OF TRANSPORTATION DIVISION OF HIGHWAYS ENGINEERING DIVISION		
PROJECT LOCATION	BUFFALO RUN BRIDGE		
PROJECT DRAWN BY	W. J. BROWN		
PROJECT CHECKED BY	W. J. BROWN		
PROJECT DATE	MAY 17 1954		
PROJECT SHEET NO.	STANDARD SHEET BR-1013		

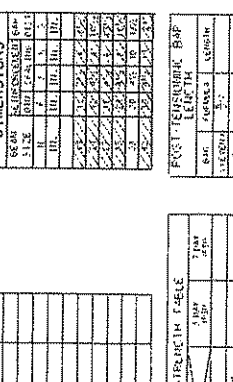
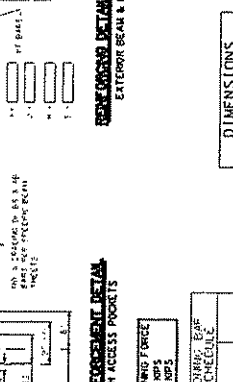
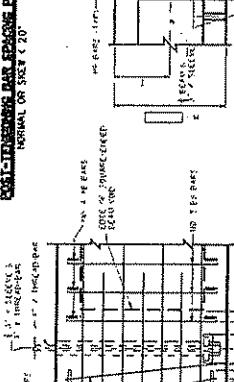
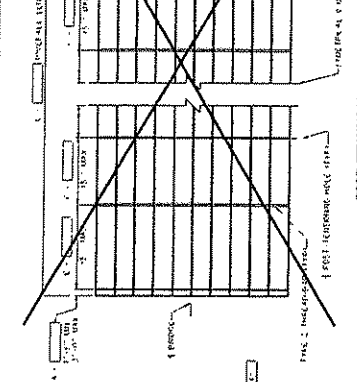

PROJECT NO.	104	DATE	05 17 54
PROJECT NAME	WEST VIRGINIA DEPARTMENT OF TRANSPORTATION DIVISION OF HIGHWAYS ENGINEERING DIVISION		
PROJECT LOCATION	BUFFALO RUN BRIDGE		
PROJECT DRAWN BY	W. J. BROWN		
PROJECT CHECKED BY	W. J. BROWN		
PROJECT DATE	MAY 17 1954		
PROJECT SHEET NO.	STANDARD SHEET BR-1013		

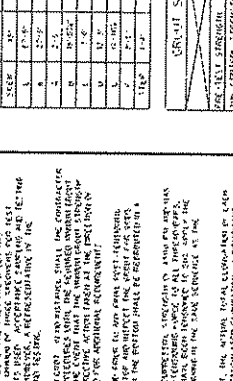
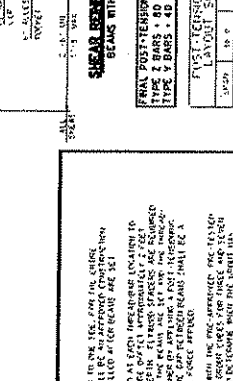
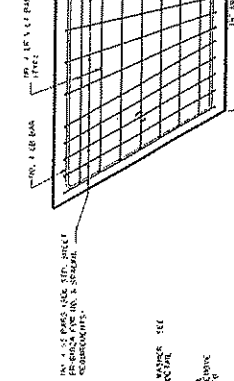
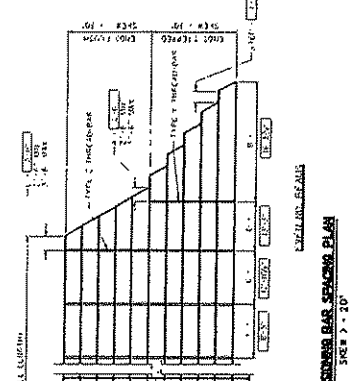

PROJECT NO.	104	DATE	05 17 54
PROJECT NAME	WEST VIRGINIA DEPARTMENT OF TRANSPORTATION DIVISION OF HIGHWAYS ENGINEERING DIVISION		
PROJECT LOCATION	BUFFALO RUN BRIDGE		
PROJECT DRAWN BY	W. J. BROWN		
PROJECT CHECKED BY	W. J. BROWN		
PROJECT DATE	MAY 17 1954		
PROJECT SHEET NO.	STANDARD SHEET BR-1013		

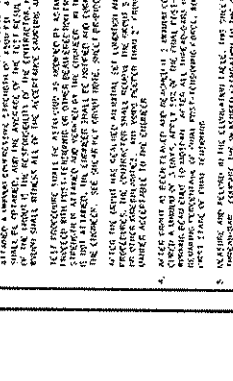
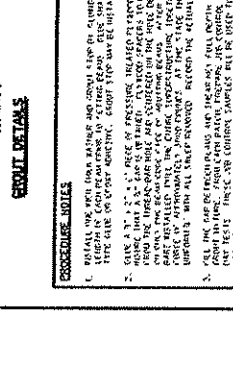
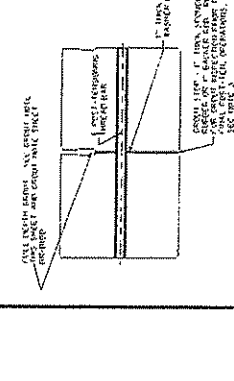
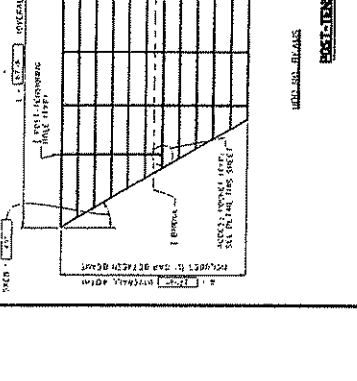

PROJECT NO.	104	DATE	05 17 54
PROJECT NAME	WEST VIRGINIA DEPARTMENT OF TRANSPORTATION DIVISION OF HIGHWAYS ENGINEERING DIVISION		
PROJECT LOCATION	BUFFALO RUN BRIDGE		
PROJECT DRAWN BY	W. J. BROWN		
PROJECT CHECKED BY	W. J. BROWN		
PROJECT DATE	MAY 17 1954		
PROJECT SHEET NO.	STANDARD SHEET BR-1013		



PROJECT NO.	104	DATE	05 17 54
PROJECT NAME	WEST VIRGINIA DEPARTMENT OF TRANSPORTATION DIVISION OF HIGHWAYS ENGINEERING DIVISION		
PROJECT LOCATION	BUFFALO RUN BRIDGE		
PROJECT DRAWN BY	W. J. BROWN		
PROJECT CHECKED BY	W. J. BROWN		
PROJECT DATE	MAY 17 1954		
PROJECT SHEET NO.	STANDARD SHEET BR-1013		

CONCRETE NOTES

1. DETAIL THE END ANCHORAGE AND DEVELOPMENT OF ALL BARS IN THE BRIDGE. THE END ANCHORAGE AND DEVELOPMENT SHALL BE AS SHOWN IN THE DRAWINGS.
2. ALL BARS SHALL BE PLACED IN THE BRIDGE AS SHOWN IN THE DRAWINGS. THE BARS SHALL BE PLACED IN THE BRIDGE AS SHOWN IN THE DRAWINGS. THE BARS SHALL BE PLACED IN THE BRIDGE AS SHOWN IN THE DRAWINGS.
3. THE END ANCHORAGE AND DEVELOPMENT OF ALL BARS IN THE BRIDGE SHALL BE AS SHOWN IN THE DRAWINGS. THE END ANCHORAGE AND DEVELOPMENT SHALL BE AS SHOWN IN THE DRAWINGS. THE END ANCHORAGE AND DEVELOPMENT SHALL BE AS SHOWN IN THE DRAWINGS.
4. THE END ANCHORAGE AND DEVELOPMENT OF ALL BARS IN THE BRIDGE SHALL BE AS SHOWN IN THE DRAWINGS. THE END ANCHORAGE AND DEVELOPMENT SHALL BE AS SHOWN IN THE DRAWINGS. THE END ANCHORAGE AND DEVELOPMENT SHALL BE AS SHOWN IN THE DRAWINGS.
5. THE END ANCHORAGE AND DEVELOPMENT OF ALL BARS IN THE BRIDGE SHALL BE AS SHOWN IN THE DRAWINGS. THE END ANCHORAGE AND DEVELOPMENT SHALL BE AS SHOWN IN THE DRAWINGS. THE END ANCHORAGE AND DEVELOPMENT SHALL BE AS SHOWN IN THE DRAWINGS.
6. THE END ANCHORAGE AND DEVELOPMENT OF ALL BARS IN THE BRIDGE SHALL BE AS SHOWN IN THE DRAWINGS. THE END ANCHORAGE AND DEVELOPMENT SHALL BE AS SHOWN IN THE DRAWINGS. THE END ANCHORAGE AND DEVELOPMENT SHALL BE AS SHOWN IN THE DRAWINGS.
7. THE END ANCHORAGE AND DEVELOPMENT OF ALL BARS IN THE BRIDGE SHALL BE AS SHOWN IN THE DRAWINGS. THE END ANCHORAGE AND DEVELOPMENT SHALL BE AS SHOWN IN THE DRAWINGS. THE END ANCHORAGE AND DEVELOPMENT SHALL BE AS SHOWN IN THE DRAWINGS.

PROJECT NO.	104	DATE	05 17 54
PROJECT NAME	WEST VIRGINIA DEPARTMENT OF TRANSPORTATION DIVISION OF HIGHWAYS ENGINEERING DIVISION		
PROJECT LOCATION	BUFFALO RUN BRIDGE		
PROJECT DRAWN BY	W. J. BROWN		
PROJECT CHECKED BY	W. J. BROWN		
PROJECT DATE	MAY 17 1954		
PROJECT SHEET NO.	STANDARD SHEET BR-1013		

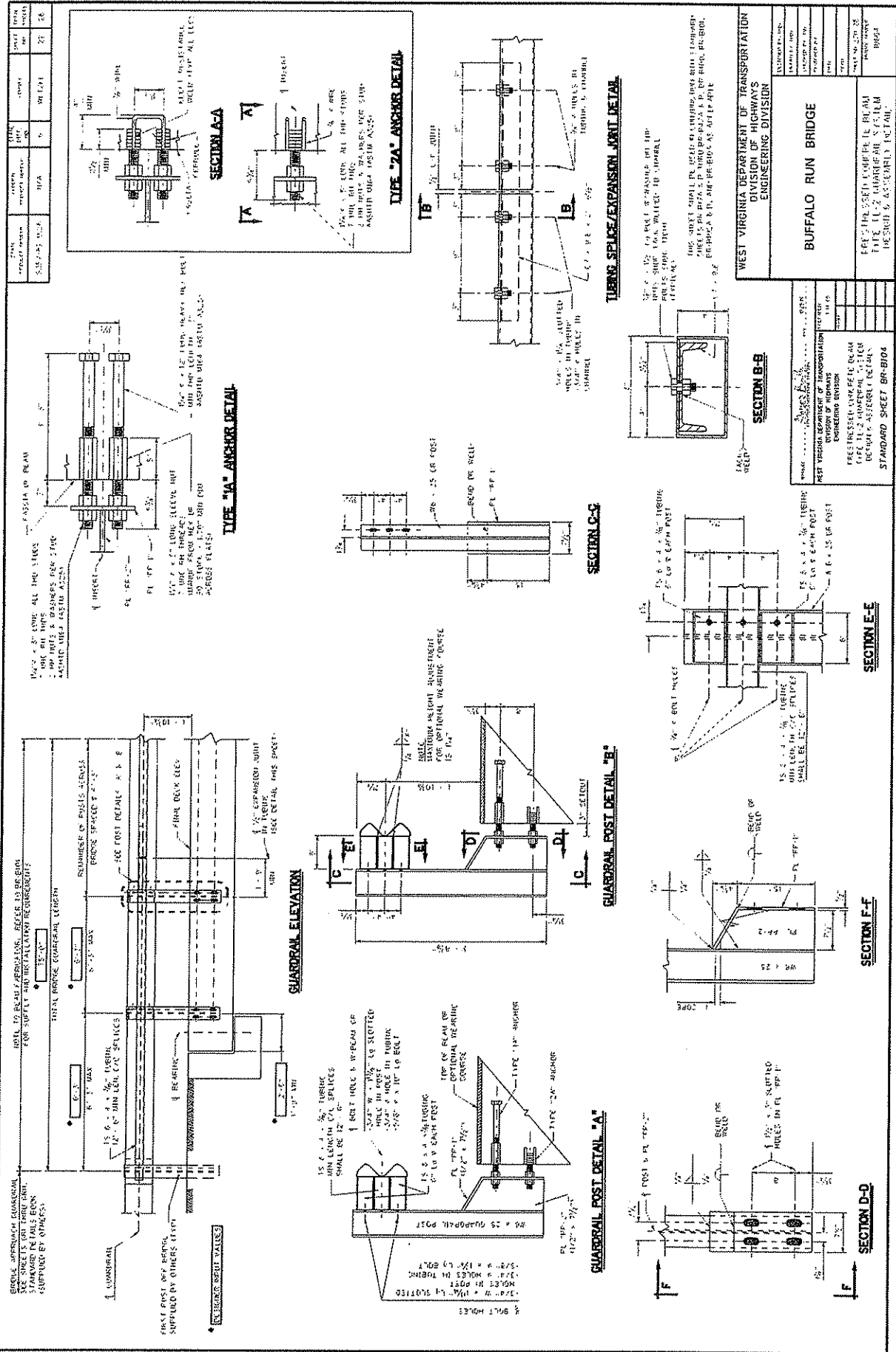

DATE	REVISION	BY	CHKD
...

WEST VIRGINIA DEPARTMENT OF TRANSPORTATION DIVISION OF HIGHWAYS ENGINEERING DIVISION	
BUFFALO RUN BRIDGE	
SHEET NO. 10 OF 12	
PROJECT NO. BR-B104	

**WEST VIRGINIA DEPARTMENT OF TRANSPORTATION
 DIVISION OF HIGHWAYS
 ENGINEERING DIVISION**

BUFFALO RUN BRIDGE

SHEET NO. 10 OF 12

PROJECT NO. BR-B104

PREPARED BY: R. L. BURK
CHECKED BY: J. H. SMITH
DESIGNED BY: W. G. ASSAULT

PROJECT NUMBER	DISTRICT	COUNTY	SHEET	TOTAL
STATE	FEDERAL	F	11	17
2012-02-R-25	17A			

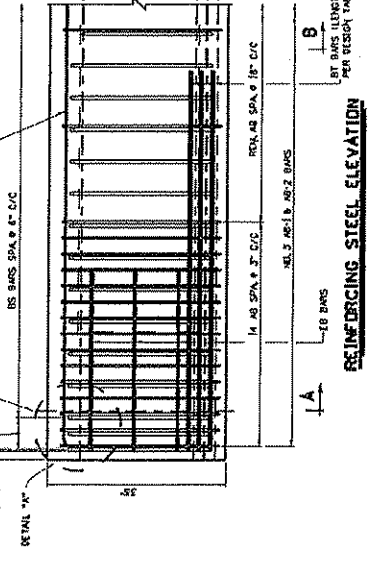
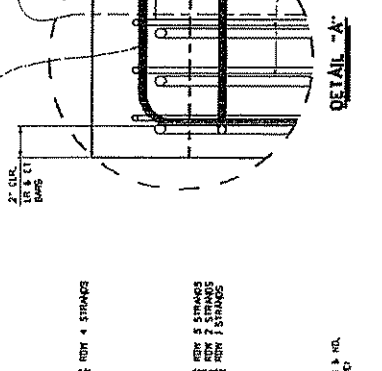
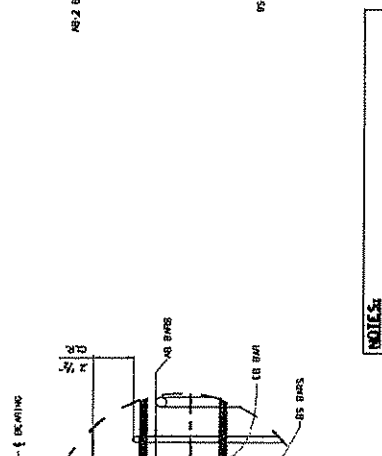
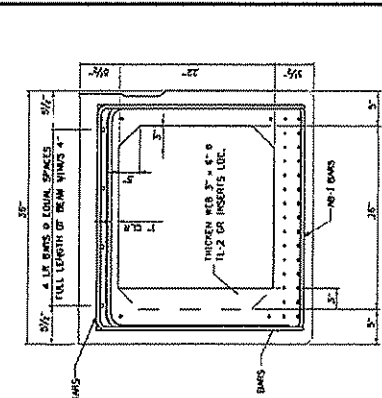
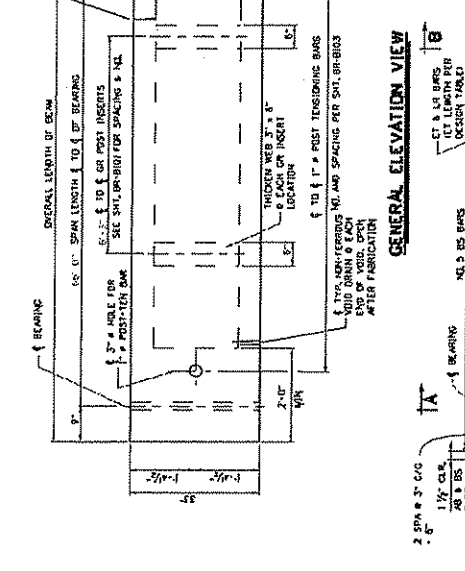
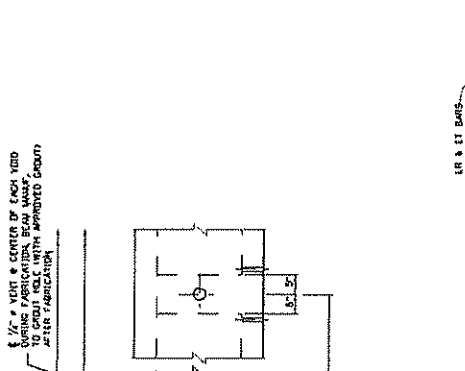
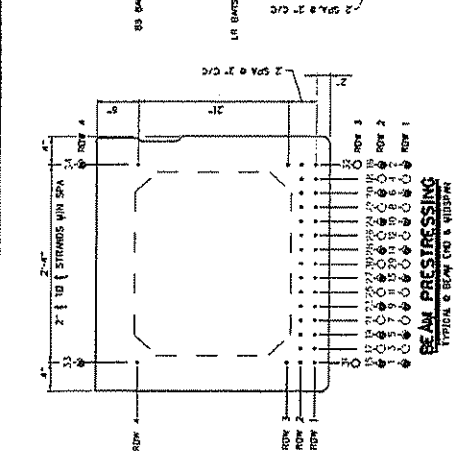

DESIGNED BY	REVIEWED BY
CHECKED BY	APPROVED BY
DATE	DATE
SHEET	NO. OF SHEETS
33	114

BUFFALO RUN BRIDGE

WEST VIRGINIA DEPARTMENT OF TRANSPORTATION
DIVISION OF HIGHWAYS
ENGINEERING DIVISION

33" PRESTRESSED BOX BEAM
DESIGN AND ASSEMBLY DETAILS

NOTES:

- REFER TO SHEET BR-003A FOR SHEET SET DETAILS.
- DESIGNER SHALL USE THE FOLLOWING KEY TO INDICATE REINFORCING PATTERN ON BEAM PRESTRESSING VIEW: THIS SHEET
 - - ACTIVE STRAND
 - △ - DEBOND STRAND LENGTH FROM END OF BEAM
 - - DEBOND STRAND LENGTH FROM END OF BEAM
- THIS SHEET SHALL BE USED IN CONJUNCTION WITH BR-003A & B, BR-003A, BR-003B, BR-003C & D AND BR-003E AS APPLICABLE.

WEST VIRGINIA DEPARTMENT OF TRANSPORTATION
DIVISION OF HIGHWAYS
ENGINEERING DIVISION

07-02-01

33" PRESTRESSED CONCRETE
BOX BEAMS
DESIGN AND ASSEMBLY DETAILS

STANDARD SHEET BR-R3A

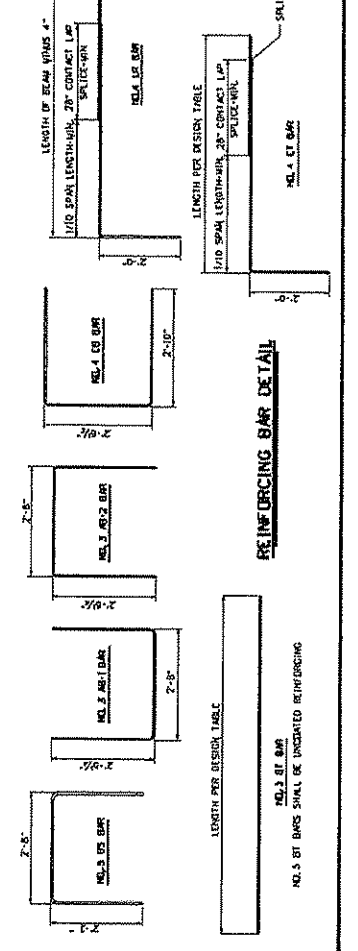

VENDOR PREFERENCE CERTIFICATE

Certification and application* is hereby made for Preference in accordance with West Virginia Code, §5A-3-37. (Does not apply to construction contracts). West Virginia Code, §5A-3-37, provides an opportunity for qualifying vendors to request (at the time of bid) preference for their residency status. Such preference is an evaluation method only and will be applied only to the cost bid in accordance with the West Virginia Code. This certificate for application is to be used to request such preference. The Purchasing Division will make the determination of the Resident Vendor Preference, if applicable.

- 1. Application is made for 2.5% resident vendor preference for the reason checked: Bidder is an individual resident vendor and has resided continuously in West Virginia for four (4) years immediately preceding the date of this certification; or, Bidder is a partnership, association or corporation resident vendor and has maintained its headquarters or principal place of business continuously in West Virginia for four (4) years immediately preceding the date of this certification; or 80% of the ownership interest of Bidder is held by another individual, partnership, association or corporation resident vendor who has maintained its headquarters or principal place of business continuously in West Virginia for four (4) years immediately preceding the date of this certification; or, Bidder is a nonresident vendor which has an affiliate or subsidiary which employs a minimum of one hundred state residents and which has maintained its headquarters or principal place of business within West Virginia continuously for the four (4) years immediately preceding the date of this certification; or,
2. Application is made for 2.5% resident vendor preference for the reason checked: Bidder is a resident vendor who certifies that, during the life of the contract, on average at least 75% of the employees working on the project being bid are residents of West Virginia who have resided in the state continuously for the two years immediately preceding submission of this bid; or,
3. Application is made for 2.5% resident vendor preference for the reason checked: Bidder is a nonresident vendor employing a minimum of one hundred state residents or is a nonresident vendor with an affiliate or subsidiary which maintains its headquarters or principal place of business within West Virginia employing a minimum of one hundred state residents who certifies that, during the life of the contract, on average at least 75% of the employees or Bidder's affiliate's or subsidiary's employees are residents of West Virginia who have resided in the state continuously for the two years immediately preceding submission of this bid; or,
4. [checked] Application is made for 5% resident vendor preference for the reason checked: Bidder meets either the requirement of both subdivisions (1) and (2) or subdivision (1) and (3) as stated above; or,
5. Application is made for 3.5% resident vendor preference who is a veteran for the reason checked: Bidder is an individual resident vendor who is a veteran of the United States armed forces, the reserves or the National Guard and has resided in West Virginia continuously for the four years immediately preceding the date on which the bid is submitted; or,
6. Application is made for 3.5% resident vendor preference who is a veteran for the reason checked: Bidder is a resident vendor who is a veteran of the United States armed forces, the reserves or the National Guard, if, for purposes of producing or distributing the commodities or completing the project which is the subject of the vendor's bid and continuously over the entire term of the project, on average at least seventy-five percent of the vendor's employees are residents of West Virginia who have resided in the state continuously for the two immediately preceding years.

Bidder understands if the Secretary of Revenue determines that a Bidder receiving preference has failed to continue to meet the requirements for such preference, the Secretary may order the Director of Purchasing to: (a) reject the bid; or (b) assess a penalty against such Bidder in an amount not to exceed 5% of the bid amount and that such penalty will be paid to the contracting agency or deducted from any unpaid balance on the contract or purchase order.

By submission of this certificate, Bidder agrees to disclose any reasonably requested information to the Purchasing Division and authorizes the Department of Revenue to disclose to the Director of Purchasing appropriate information verifying that Bidder has paid the required business taxes, provided that such information does not contain the amounts of taxes paid nor any other information deemed by the Tax Commissioner to be confidential.

Under penalty of law for false swearing (West Virginia Code, §61-5-3), Bidder hereby certifies that this certificate is true and accurate in all respects; and that if a contract is issued to Bidder and if anything contained within this certificate changes during the term of the contract, Bidder will notify the Purchasing Division in writing immediately.

Bidder: Carr Concrete Corp Signed: RE "Bum" Stanley
Date: 10/5/09 Title: Project Manager

*Check any combination of preference consideration(s) indicated above, which you are entitled to receive.

STATE OF WEST VIRGINIA
Purchasing Division**PURCHASING AFFIDAVIT****VENDOR OWING A DEBT TO THE STATE:**

West Virginia Code §5A-3-10a provides that: No contract or renewal of any contract may be awarded by the state or any of its political subdivisions to any vendor or prospective vendor when the vendor or prospective vendor or a related party to the vendor or prospective vendor is a debtor and the debt owed is an amount greater than one thousand dollars in the aggregate.

PUBLIC IMPROVEMENT CONTRACTS & DRUG-FREE WORKPLACE ACT:

If this is a solicitation for a public improvement construction contract, the vendor, by its signature below, affirms that it has a written plan for a drug-free workplace policy in compliance with Article 1D, Chapter 21 of the *West Virginia Code*. The vendor **must** make said affirmation with its bid submission. Further, public improvement construction contract may not be awarded to a vendor who does not have a written plan for a drug-free workplace policy in compliance with Article 1D, Chapter 21 of the *West Virginia Code* and who has not submitted that plan to the appropriate contracting authority in timely fashion. For a vendor who is a subcontractor, compliance with Section 5, Article 1D, Chapter 21 of the *West Virginia Code* may take place before their work on the public improvement is begun.

ANTITRUST:

In submitting a bid to any agency for the state of West Virginia, the bidder offers and agrees that if the bid is accepted the bidder will convey, sell, assign or transfer to the state of West Virginia all rights, title and interest in and to all causes of action it may now or hereafter acquire under the antitrust laws of the United States and the state of West Virginia for price fixing and/or unreasonable restraints of trade relating to the particular commodities or services purchased or acquired by the state of West Virginia. Such assignment shall be made and become effective at the time the purchasing agency tenders the initial payment to the bidder.

I certify that this bid is made without prior understanding, agreement, or connection with any corporation, firm, limited liability company, partnership or person or entity submitting a bid for the same materials, supplies, equipment or services and is in all respects fair and without collusion or fraud. I further certify that I am authorized to sign the certification on behalf of the bidder or this bid.

LICENSING:

Vendors must be licensed and in good standing in accordance with any and all state and local laws and requirements by any state or local agency of West Virginia, including, but not limited to, the West Virginia Secretary of State's Office, the West Virginia Tax Department, West Virginia Insurance Commission, or any other state agencies or political subdivision. Furthermore, the vendor must provide all necessary releases to obtain information to enable the Director or spending unit to verify that the vendor is licensed and in good standing with the above entities.

CONFIDENTIALITY:

The vendor agrees that he or she will not disclose to anyone, directly or indirectly, any such personally identifiable information or other confidential information gained from the agency, unless the individual who is the subject of the information consents to the disclosure in writing or the disclosure is made pursuant to the agency's policies, procedures and rules. Vendor further agrees to comply with the Confidentiality Policies and Information Security Accountability Requirements, set forth in <http://www.state.wv.us/admin/purchase/privacy/noticeConfidentiality.pdf>.

Under penalty of law for false swearing (*West Virginia Code* §61-5-3), it is hereby certified that the vendor affirms and acknowledges the information in this affidavit and is in compliance with the requirements as stated.

Vendor's Name: Carr Concrete CorpAuthorized Signature: RE "Burr Stanley" Date: 10/5/09