



State of West Virginia
 Department of Administration
 Purchasing Division
 2019 Washington Street East
 Post Office Box 50130
 Charleston, WV 25305-0130

Request for Quotation

RFQ NUMBER
04100433

PAGE
1

ADDRESS-CORRESPONDENCE TO ATTENTION OF:
MICHAEL AUSTIN
304-558-2402

VENDOR

***709015618 800-824-6166**
L. B FOSTER COMPANY
3493 LANSDOWNE DRIVE STE 1

LEXINGTON KY 40517

SHIP TO

DIVISION OF HIGHWAYS
DISTRICT FOUR

P.O. BOX 4220
CLARKSBURG, WV
26302-2570 304-557-1550

DATE PRINTED	TERMS OF SALE	SHIP VIA	F.O.B.	FREIGHT TERMS
02/16/2010	Net 30 days	Truck	SP/FA via truck	Delivered
BID OPENING DATE: 03/03/2010		BID OPENING TIME 01:30PM		

LINE	QUANTITY	UOP	CAT NO	ITEM NUMBER	UNIT PRICE	AMOUNT
0001	1	LS		760-69	\$ 43,778.35	\$ 43,778.35
913 SF OF 2" TEE STEEL GRID SIDEWALK TO PROVIDE 2" TEE STEEL GRID SIDEWALK FOR STATE PROJECT S325-90/3-0.03 HUTCHINSON TRUSS FOR THE WEST VIRGINIA DIVISION OF HIGHWAYS PER THE ATTACHED SPECIFICATIONS. EXHIBIT 10 REQUISITION NO.: ADDENDUM ACKNOWLEDGEMENT I HEREBY ACKNOWLEDGE RECEIPT OF THE FOLLOWING CHECKED ADDENDUM(S) AND HAVE MADE THE NECESSARY REVISIONS TO MY PROPOSAL, PLANS AND/OR SPECIFICATION, ETC. ADDENDUM NO.'S: NO. 1 .. 3/11/10 - RAR NO. 2 NO. 3 NO. 4 NO. 5 I UNDERSTAND THAT FAILURE TO CONFIRM THE RECEIPT OF THE ADDENDUM(S) MAY BE CAUSE FOR REJECTION OF BIDS.						

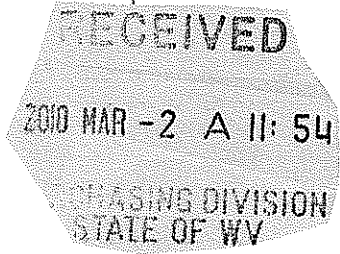

SEE REVERSE SIDE FOR TERMS AND CONDITIONS

SIGNATURE: *Richard H. Farned* TELEPHONE: 800-824-6166 DATE: 3/1/10
 TITLE: District Sales Mgr. FEIN: 25-1324733 ADDRESS CHANGES TO BE NOTED ABOVE

WHEN RESPONDING TO RFQ, INSERT NAME AND ADDRESS IN SPACE ABOVE LABELED 'VENDOR'

GENERAL TERMS & CONDITIONS REQUEST FOR QUOTATION (RFQ) AND REQUEST FOR PROPOSAL (RFP)

1. Awards will be made in the best interest of the State of West Virginia.
2. The State may accept or reject in part, or in whole, any bid.
3. Prior to any award, the apparent successful vendor must be properly registered with the Purchasing Division and have paid the required \$125 fee.
4. All services performed or goods delivered under State Purchase Order/Contracts are to be continued for the term of the Purchase Order/Contracts, contingent upon funds being appropriated by the Legislature or otherwise being made available. In the event funds are not appropriated or otherwise available for these services or goods this Purchase Order/Contract becomes void and of no effect after June 30.
5. Payment may only be made after the delivery and acceptance of goods or services.
6. Interest may be paid for late payment in accordance with the *West Virginia Code*.
7. Vendor preference will be granted upon written request in accordance with the *West Virginia Code*.
8. The State of West Virginia is exempt from federal and state taxes and will not pay or reimburse such taxes.
9. The Director of Purchasing may cancel any Purchase Order/Contract upon 30 days written notice to the seller.
10. The laws of the State of West Virginia and the *Legislative Rules* of the Purchasing Division shall govern the purchasing process.
11. Any reference to automatic renewal is hereby deleted. The Contract may be renewed only upon mutual written agreement of the parties.
12. **BANKRUPTCY:** In the event the vendor/contractor files for bankruptcy protection, the State may deem this contract null and void, and terminate such contract without further order.
13. **HIPAA BUSINESS ASSOCIATE ADDENDUM:** The West Virginia State Government HIPAA Business Associate Addendum (BAA), approved by the Attorney General, is available online at www.state.wv.us/admin/purchase/vrc/hipaa.htm and is hereby made part of the agreement. Provided that the Agency meets the definition of a Cover Entity (45 CFR §160.103) and will be disclosing Protected Health Information (45 CFR §160.103) to the vendor.
14. **CONFIDENTIALITY:** The vendor agrees that he or she will not disclose to anyone, directly or indirectly, any such personally identifiable information or other confidential information gained from the agency, unless the individual who is the subject of the information consents to the disclosure in writing or the disclosure is made pursuant to the agency's policies, procedures, and rules. Vendor further agrees to comply with the Confidentiality Policies and Information Security Accountability Requirements, set forth in <http://www.state.wv.us/admin/purchase/privacy/noticeConfidentiality.pdf>.
15. **LICENSING:** Vendors must be licensed and in good standing in accordance with any and all state and local laws and requirements by any state or local agency of West Virginia, including, but not limited to, the West Virginia Secretary of State's Office, the West Virginia Tax Department, and the West Virginia Insurance Commission. The vendor must provide all necessary releases to obtain information to enable the director or spending unit to verify that the vendor is licensed and in good standing with the above entities.
16. **ANTITRUST:** In submitting a bid to any agency for the State of West Virginia, the bidder offers and agrees that if the bid is accepted the bidder will convey, sell, assign or transfer to the State of West Virginia all rights, title and interest in and to all causes of action it may now or hereafter acquire under the antitrust laws of the United States and the State of West Virginia for price fixing and/or unreasonable restraints of trade relating to the particular commodities or services purchased or acquired by the State of West Virginia. Such assignment shall be made and become effective at the time the purchasing agency tenders the initial payment to the bidder.

I certify that this bid is made without prior understanding, agreement, or connection with any corporation, firm, limited liability company, partnership, or person or entity submitting a bid for the same material, supplies, equipment or services and is in all respects fair and without collusion or fraud. I further certify that I am authorized to sign the certification on behalf of the bidder or this bid.

INSTRUCTIONS TO BIDDERS

1. Use the quotation forms provided by the Purchasing Division. Complete all sections of the quotation form.
2. Items offered must be in compliance with the specifications. Any deviation from the specifications must be clearly indicated by the bidder. Alternates offered by the bidder as **EQUAL** to the specifications must be clearly defined. A bidder offering an alternate should attach complete specifications and literature to the bid. The Purchasing Division may waive minor deviations to specifications.
3. Unit prices shall prevail in case of discrepancy. All quotations are considered F.O.B. destination unless alternate shipping terms are clearly identified in the quotation.
4. All quotations must be delivered by the bidder to the office listed below prior to the date and time of the bid opening. Failure of the bidder to deliver the quotations on time will result in bid disqualifications: Department of Administration, Purchasing Division, 2019 Washington Street East, P.O. Box 50130, Charleston, WV 25305-0130
5. Communication during the solicitation, bid, evaluation or award periods, except through the Purchasing Division, is strictly prohibited (W.Va. C.S.R. §148-1-6.6).



State of West Virginia
 Department of Administration
 Purchasing Division
 2019 Washington Street East
 Post Office Box 50130
 Charleston, WV 25305-0130

Request for Quotation

RFQ NUMBER
 04100433

PAGE
 3

ADDRESS CORRESPONDENCE TO ATTENTION OF
 MICHAEL AUSTIN
 304-558-2402

VENDOR

*709015618 800-824-6166
 L B FOSTER COMPANY
 3493 LANSDOWNE DRIVE STE 1
 LEXINGTON KY 40517

SHIP TO

DIVISION OF HIGHWAYS
 DISTRICT FOUR
 P.O. BOX 4220
 CLARKSBURG, WV
 26302-2570 304-557-1550

DATE PRINTED 02/16/2010	TERMS OF SALE	SHIP VIA	F.O.B.	FREIGHT TERMS
----------------------------	---------------	----------	--------	---------------

BID OPENING DATE: 03/03/2010		BID OPENING TIME 01:30PM				
LINE	QUANTITY	UOP	CAT NO	ITEM NUMBER	UNIT PRICE	AMOUNT

THE BID SHOULD CONTAIN THIS INFORMATION ON THE FACE OF THE ENVELOPE OR THE BID MAY NOT BE CONSIDERED:

SEALED BID

BUYER: -----

RFQ. NO.: -----

BID OPENING DATE: -----

BID OPENING TIME: -----

PLEASE PROVIDE A FAX NUMBER IN CASE IT IS NECESSARY TO CONTACT YOU REGARDING YOUR BID:

859-245-1768

CONTACT PERSON (PLEASE PRINT CLEARLY):

Richard Fifield

***** THIS IS THE END OF RFQ 04100433 ***** TOTAL:

\$ 43,778.35

SEE REVERSE SIDE FOR TERMS AND CONDITIONS

SIGNATURE: *Richard H. Fifield* TELEPHONE: 800-824-6166 DATE: 3/1/10

TITLE: District Sales Mgr. FEIN: 25-1324733 ADDRESS CHANGES TO BE NOTED ABOVE

WHEN RESPONDING TO RFQ, INSERT NAME AND ADDRESS IN SPACE ABOVE LABELED 'VENDOR'



State of West Virginia
 Department of Administration
 Purchasing Division
 2019 Washington Street East
 Post Office Box 50130
 Charleston, WV 25305-0130

Request for Quotation

RFO NUMBER
04100433

PAGE
2

ADDRESS CORRESPONDENCE TO ATTENTION OF:
MICHAEL AUSTIN
304-558-2402

RODNEY

*709015618 800-824-6166
L B FOSTER COMPANY
3493 LANSLOWNE DRIVE STE 1

LEXINGTON KY 40517

SHIP TO

DIVISION OF HIGHWAYS
DISTRICT FOUR

P.O. BOX 4220
CLARKSBURG, WV
26302-2570 304-557-1550

DATE PRINTED 02/16/2010	TERMS OF SALE	SHIP VIA	F.O.B.	FREIGHT TERMS
BID OPENING DATE: 03/03/2010		BID OPENING TIME 01:30PM		

LINE	QUANTITY	UOP	CAT. NO.	ITEM NUMBER	UNIT PRICE	AMOUNT
<p>VENDOR MUST CLEARLY UNDERSTAND THAT ANY VERBAL REPRESENTATION MADE OR ASSUMED TO BE MADE DURING ANY ORAL DISCUSSION HELD BETWEEN VENDOR'S REPRESENTATIVES AND ANY STATE PERSONNEL IS NOT BINDING. ONLY THE INFORMATION ISSUED IN WRITING AND ADDED TO THE SPECIFICATIONS BY AN OFFICIAL ADDENDUM IS BINDING.</p> <p style="text-align: right;"> <i>Richard H. Foyed</i> SIGNATURE <i>L. B. Foster Co.</i> COMPANY 3/1/10 DATE </p> <p>NOTE: THIS ADDENDUM ACKNOWLEDGEMENT SHOULD BE SUBMITTED WITH THE BID.</p> <p>REV. 09/21/2009</p> <p style="text-align: center;">NOTICE</p> <p>A SIGNED BID MUST BE SUBMITTED TO:</p> <p style="text-align: center;"> DEPARTMENT OF ADMINISTRATION PURCHASING DIVISION BUILDING 15 2019 WASHINGTON STREET, EAST CHARLESTON, WV 25305-0130 </p>						

SEE REVERSE SIDE FOR TERMS AND CONDITIONS

SIGNATURE <i>RBF</i>	TELEPHONE	DATE 3/1/10
TITLE	FEIN	ADDRESS CHANGES TO BE NOTED ABOVE

WHEN RESPONDING TO RFQ, INSERT NAME AND ADDRESS IN SPACE ABOVE LABELED 'VENDOR'

DESCRIPTION

The steel grid shall meet the requirements of Section 621 of the West Virginia Division of Highways Standard Specifications, Roads and Bridges, adopted 2000. The steel grid sidewalk shall be constructed with rolled steel shapes and sheet metal form pans. The main rails shall be ST2X3.85 and cross bars shall be 1/4"X 1". Trim bars shall be the size and placed as shown on the plans. All panels shall have a 3/8"X 3" flat bar welded the full length of each side. The form pans shall be omitted over the supporting beam flanges. The steel shall meet AASHTO M183 grade 36 or 50. The sidewalk panels shall be supplied in the exact lengths as shown on the plans.

Alternate designs may be accepted and must be approved by the District Bridge Engineer.

The sidewalk panels shall be galvanized after fabrication in accordance with AASHTO M111.

Shop drawings are required and shall be submitted for approval to the District Bridge Engineer:

Stephen R. Harris

WV DOT Division of Highways

P.O. Box 4220

Clarksburg, WV 26302-4220

Fabrication shall not begin until the drawings have been approved.

The completed decking is subject to inspection by a representative of the Division of Highways prior to shipping. Any materials not meeting the requirements of the plans or specifications shall be rejected.

Upon receipt of a Purchase Order the Vendor shall submit shop drawings to the District Bridge Engineer within twenty (20) calendar days. After the drawings have been approved and returned to the vendor, the decking shall be fabricated, galvanized and ready for delivery within ninety (90) calendar days. The delivery shall be coordinated with the District 4 Bridge Department (304-842-1511). Delivery shall be made to West Virginia Division of Highways District Four Headquarters, Meadowbrook Road, Bridgeport WV 26330, located off I-79 Exit 121.

Should the Vendor fail to meet the above delivery schedule, liquidated damages will be assessed in accordance with Section 108.7 of the current Division of Highways Standard Specifications Roads and Bridges.

Payment shall be made on a lump sum basis for all material as shown or indicated on the plans and specifications including delivery.



State of West Virginia
 Department of Administration
 Purchasing Division
 2019 Washington Street East
 Post Office Box 50130
 Charleston, WV 25305-0130

Request for Quotation

RFQ NUMBER
 04100433

PAGE
 1

ADDRESS CORRESPONDENCE TO ATTENTION OF:
 MICHAEL AUSTIN
 304-558-2402

VENDOR

*709015618 800-824-6166
 L B FOSTER COMPANY
 3493 LANSLOWNE DRIVE STE 1

 LEXINGTON KY 40517

SHIP TO

DIVISION OF HIGHWAYS
 DISTRICT FOUR

 P.O. BOX 4220
 CLARKSBURG, WV
 26302-2570 304-557-1550

DATE PRINTED 02/25/2010	TERMS OF SALE <i>net 30 days</i>	SHIP VIA <i>Truck</i>	F.O.B. <i>SP/FA via truck</i>	FREIGHT TERMS <i>Delivered</i>
BID OPENING DATE: 03/03/2010		BID OPENING TIME 01:30PM		

LINE	QUANTITY	UOP	CAT. NO.	ITEM NUMBER	UNIT PRICE	AMOUNT
ADDENDUM NO. 1						
ADD: PAGE 5 OF DRAWINGS						
BID OPENING DATE AND TIME REMAINS 03/03/10 @1:30 P.M.						
NO OTHER CHANGES.						
0001	1	LS		760-69	\$ 43,778.35	43,778.35
	913 SF OF 2"	TEE	STEEL	GRID SIDEWALK		
***** THIS IS THE END OF RFQ 04100433 ***** TOTAL:						<u>43,778.35</u>

SEE REVERSE SIDE FOR TERMS AND CONDITIONS

SIGNATURE <i>Richard H. Field</i>	TELEPHONE 800-824-6166	DATE 3/1/10
TITLE <i>District Sales</i>	FEIN 25-1324733	ADDRESS CHANGES TO BE NOTED ABOVE

WHEN RESPONDING TO RFQ, INSERT NAME AND ADDRESS IN SPACE ABOVE LABELED 'VENDOR'



State of West Virginia
 Department of Administration
 Purchasing Division
 2019 Washington Street East
 Post Office Box 50130
 Charleston, WV 25305-0130

Request for Quotation

RFQ NUMBER
04100433

PAGE
1

ADDRESS CORRESPONDENCE TO ATTENTION OF
MICHAEL AUSTIN 304-558-2402

VENDOR

*709015618 800-824-6166
 L B FOSTER COMPANY
 3493 LANSDOWNE DRIVE STE 1

 LEXINGTON KY 40517

SHIP TO

DIVISION OF HIGHWAYS
 DISTRICT FOUR

 P.O. BOX 4220
 CLARKSBURG, WV
 26302-2570 304-557-1550

DATE PRINTED	TERMS OF SALE	SHIP VIA	F.O.B.	FREIGHT TERMS
03/01/2010	Net 30 Days	TRUCK	SIIFA	Delivered

BID OPENING DATE: 03/10/2010 BID OPENING TIME 01:30PM

LINE	QUANTITY	UOP	CAT NO	ITEM NUMBER	UNIT PRICE	AMOUNT
ADDENDUM NO. 2						
CHANGES TO THE DRAWINGS ATTACHED.						
PLAN SHEETS 5 & 6 HAVE BEEN REVISED TO ADD THE FIELD WELD SYMBOLS.						
BID OPENING DATE AND TIME CHANGED						
FROM: 03/03/10 @1:30 P.M.						
TO: 03/10/10 @1:30 P.M.						
NO OTHER CHANGES.						
0001	1	LS		760-69	\$ 43778.35	\$ 43778.35
	913 SF OF 2"	TEE STEEL		GRID SIDEWALK		
THIS IS THE END OF RFQ 04100433 ***** TOTAL:						\$ 43778.35



SEE REVERSE SIDE FOR TERMS AND CONDITIONS		
SIGNATURE: Richard H. Speed	TELEPHONE: 800-824-6166	DATE: 3/5/10
TITLE: District Sales Mgr	FAX: 25-1334733	ADDRESS CHANGES TO BE NOTED ABOVE

WHEN RESPONDING TO RFQ, INSERT NAME AND ADDRESS IN SPACE ABOVE LABELED 'VENDOR'

NO. OF SHEETS	START PROJECT NO.	DATE	CONTR.	DATE
4	5325-RD/3-D-03	2010	MARCH	5 8

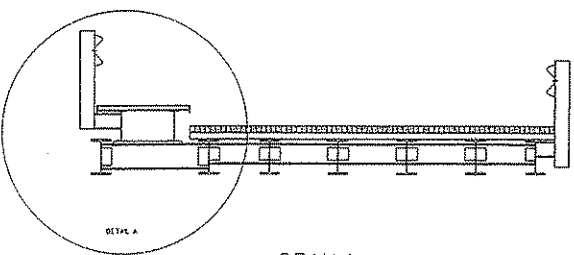

SPAN 1

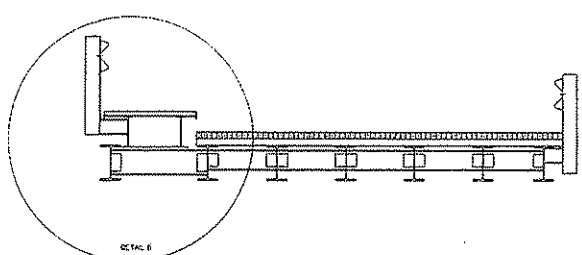

SPAN 4

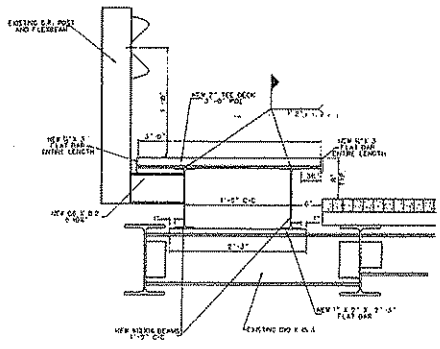

DETAIL A

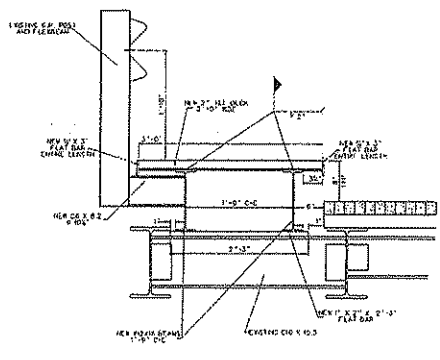

DETAIL B

NOTE: ALL CROSS SECTION VIEWS ARE LOOKING FORWARD
ALL BEAMS, PLATES, AND TEE DECK ARE WELDED

REVISION	DATE	BY	REASON
1	12/09		ADDED FIELD WIND STIFFENERS
2	12/09		
3	12/09		
4	12/09		

THE WEST VIRGINIA DEPARTMENT OF TRANSPORTATION
DIVISION OF HIGHWAYS
DISTRICT FOUR BRIDGE DEPARTMENT
HUTCHINSON TRUSS BRIDGE
PROPOSED CROSS SECTION
VIEWS SPAN 1 AND 4

SHEET 5 of 8
PROJECT NO. 6822.2

Project No.	Sheet No.	State Proj./Dist. No.	Project Year	County	Sheet No.	Total Sheets
W.V. 4	4	5325-90/3-0-03	2010	MARION	6	8

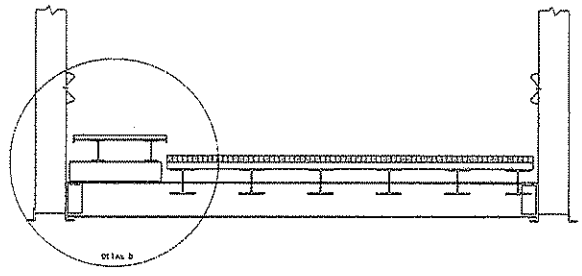
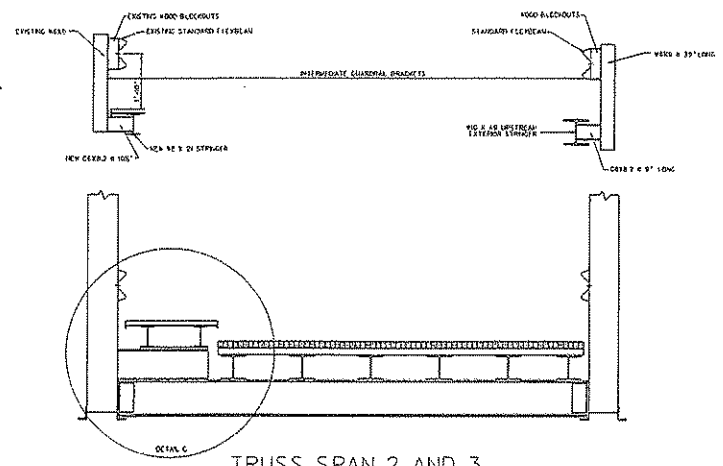

TRUSS SPAN 2 AND 3

TRUSS @ L1 AND L11

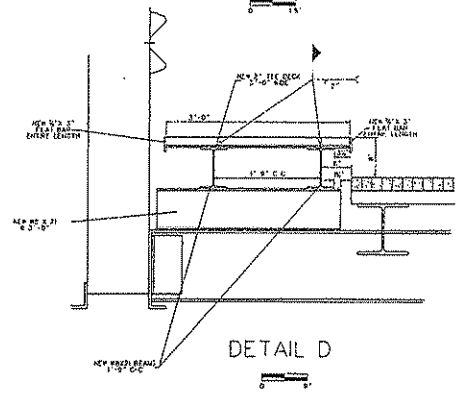
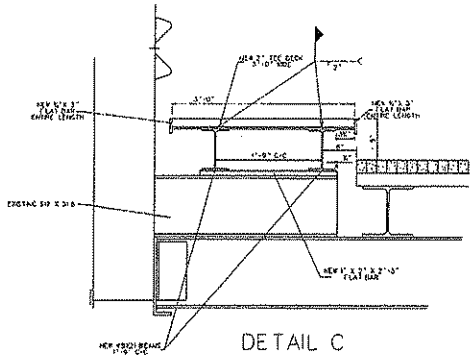

NOTE: ALL CROSS SECTION VIEWS ARE LOOKING FORWARD
ALL BEAMS, PLATES, AND TEE DECK ARE WELDED.

DESIGNED BY:	ALS	12/09	1	6	JENNIFER WILKINS	REVISION	ALL	THE WEST VIRGINIA DEPARTMENT OF TRANSPORTATION
DRAWN BY:	ALL	12/09						DIVISION OF HIGHWAYS
CHECKED BY:	ALL	12/09						DISTRICT FOUR BRIDGE DEPARTMENT
DATE:	12/09							HUTCHINSON TRUSS BRIDGE
BY:								PROPOSED CROSS SECTION
								VIEWS SPAN 2 AND 3
								SHEET 6 OF 8
								PROJECT NO. 5622.2

8/13/10
 12/23/09 (03)
 5/11/10
 12/23/09 (03)

VENDOR PREFERENCE CERTIFICATE

Certification and application* is hereby made for Preference in accordance with *West Virginia Code*, §5A-3-37. (Does not apply to construction contracts). *West Virginia Code*, §5A-3-37, provides an opportunity for qualifying vendors to request (at the time of bid) preference for their residency status. Such preference is an evaluation method only and will be applied only to the cost bid in accordance with the *West Virginia Code*. This certificate for application is to be used to request such preference. The Purchasing Division will make the determination of the Resident Vendor Preference, if applicable.

1. Application is made for 2.5% resident vendor preference for the reason checked:

- Bidder is an individual resident vendor and has resided continuously in West Virginia for four (4) years immediately preceding the date of this certification; **or,**
- Bidder is a partnership, association or corporation resident vendor and has maintained its headquarters or principal place of business continuously in West Virginia for four (4) years immediately preceding the date of this certification; **or 80% of the ownership interest of Bidder is held by another individual, partnership, association or corporation resident vendor who has maintained its headquarters or principal place of business continuously in West Virginia for four (4) years immediately preceding the date of this certification; or,**
- Bidder is a nonresident vendor which has an affiliate or subsidiary which employs a minimum of one hundred state residents and which has maintained its headquarters or principal place of business within West Virginia continuously for the four (4) years immediately preceding the date of this certification; **or,**

2. Application is made for 2.5% resident vendor preference for the reason checked:

Bidder is a resident vendor who certifies that, during the life of the contract, on average at least 75% of the employees working on the project being bid are residents of West Virginia who have resided in the state continuously for the two years immediately preceding submission of this bid; **or,**

3. Application is made for 2.5% resident vendor preference for the reason checked:

Bidder is a nonresident vendor employing a minimum of one hundred state residents or is a nonresident vendor with an affiliate or subsidiary which maintains its headquarters or principal place of business within West Virginia employing a minimum of one hundred state residents who certifies that, during the life of the contract, on average at least 75% of the employees or Bidder's affiliate's or subsidiary's employees are residents of West Virginia who have resided in the state continuously for the two years immediately preceding submission of this bid; **or,**

4. Application is made for 5% resident vendor preference for the reason checked:

Bidder meets either the requirement of both subdivisions (1) and (2) or subdivision (1) and (3) as stated above; **or,**

5. Application is made for 3.5% resident vendor preference who is a veteran for the reason checked:

Bidder is an individual resident vendor who is a veteran of the United States armed forces, the reserves or the National Guard and has resided in West Virginia continuously for the four years immediately preceding the date on which the bid is submitted; **or,**

6. Application is made for 3.5% resident vendor preference who is a veteran for the reason checked:

Bidder is a resident vendor who is a veteran of the United States armed forces, the reserves or the National Guard, if, for purposes of producing or distributing the commodities or completing the project which is the subject of the vendor's bid and continuously over the entire term of the project, on average at least seventy-five percent of the vendor's employees are residents of West Virginia who have resided in the state continuously for the two immediately preceding years.

Bidder understands if the Secretary of Revenue determines that a Bidder receiving preference has failed to continue to meet the requirements for such preference, the Secretary may order the Director of Purchasing to: (a) reject the bid; or (b) assess a penalty against such Bidder in an amount not to exceed 5% of the bid amount and that such penalty will be paid to the contracting agency or deducted from any unpaid balance on the contract or purchase order.

By submission of this certificate, Bidder agrees to disclose any reasonably requested information to the Purchasing Division and authorizes the Department of Revenue to disclose to the Director of Purchasing appropriate information verifying that Bidder has paid the required business taxes, provided that such information does not contain the amounts of taxes paid nor any other information deemed by the Tax Commissioner to be confidential.

Under penalty of law for false swearing (West Virginia Code, §61-5-3), Bidder hereby certifies that this certificate is true and accurate in all respects; and that if a contract is issued to Bidder and if anything contained within this certificate changes during the term of the contract, Bidder will notify the Purchasing Division in writing immediately.

Bidder: _____

Signed: _____

Date: _____

Title: _____

N/A

*Check any combination of preference consideration(s) indicated above, which you are entitled to receive.

RJP 3/1/10

STATE OF WEST VIRGINIA
Purchasing Division

PURCHASING AFFIDAVIT

West Virginia Code §5A-3-10a states: No contract or renewal of any contract may be awarded by the state or any of its political subdivisions to any vendor or prospective vendor when the vendor or prospective vendor or a related party to the vendor or prospective vendor is a debtor and the debt owed is an amount greater than one thousand dollars in the aggregate.

DEFINITIONS:

"Debt" means any assessment, premium, penalty, fine, tax or other amount of money owed to the state or any of its political subdivisions because of a judgment, fine, permit violation, license assessment, defaulted workers' compensation premium, penalty or other assessment presently delinquent or due and required to be paid to the state or any of its political subdivisions, including any interest or additional penalties accrued thereon.

"Debtor" means any individual, corporation, partnership, association, limited liability company or any other form or business association owing a debt to the state or any of its political subdivisions. "Political subdivision" means any county commission; municipality; county board of education; any instrumentality established by a county or municipality; any separate corporation or instrumentality established by one or more counties or municipalities, as permitted by law; or any public body charged by law with the performance of a government function or whose jurisdiction is coextensive with one or more counties or municipalities. "Related party" means a party, whether an individual, corporation, partnership, association, limited liability company or any other form or business association or other entity whatsoever, related to any vendor by blood, marriage, ownership or contract through which the party has a relationship of ownership or other interest with the vendor so that the party will actually or by effect receive or control a portion of the benefit, profit or other consideration from performance of a vendor contract with the party receiving an amount that meets or exceeds five percent of the total contract amount.

EXCEPTION: The prohibition of this section does not apply where a vendor has contested any tax administered pursuant to chapter eleven of this code, workers' compensation premium, permit fee or environmental fee or assessment and the matter has not become final or where the vendor has entered into a payment plan or agreement and the vendor is not in default of any of the provisions of such plan or agreement.

Under penalty of law for false swearing (*West Virginia Code* §61-5-3), it is hereby certified that the vendor affirms and acknowledges the information in this affidavit and is in compliance with the requirements as stated.

WITNESS THE FOLLOWING SIGNATURE

Vendor's Name: L. B. Foster Co.

Authorized Signature: Richard H. Speed Date: 3/1/10

State of Kentucky

County of Fayette, to-wit:

Taken, subscribed, and sworn to before me this 1st day of March, 2010

My Commission expires July 27, 2011.

AFFIX SEAL HERE

NOTARY PUBLIC Sally A. Slaton