

GENERAL TERMS & CONDITIONS REQUEST FOR QUOTATION (RFQ) AND REQUEST FOR PROPOSAL (RFP)

1. Awards will be made in the best interest of the State of West Virginia.
2. The State may accept or reject in part, or in whole, any bid.
3. All quotations are governed by the *West Virginia Code* and the *Legislative Rules* of the Purchasing Division.
4. Prior to any award, the apparent successful vendor must be properly registered with the Purchasing Division and have paid the required \$125 fee.
5. All services performed or goods delivered under State Purchase Order/Contracts are to be continued for the term of the Purchase Order/Contracts, contingent upon funds being appropriated by the Legislature or otherwise being made available. In the event funds are not appropriated or otherwise available for these services or goods, this Purchase Order/Contract becomes void and of no effect after June 30.
6. Payment may only be made after the delivery and acceptance of goods or services.
7. Interest may be paid for late payment in accordance with the *West Virginia Code*.
8. Vendor preference will be granted upon written request in accordance with the *West Virginia Code*.
9. The State of West Virginia is exempt from federal and state taxes and will not pay or reimburse such taxes.
10. The Director of Purchasing may cancel any Purchase Order/Contract upon 30 days written notice to the seller.
11. The laws of the State of West Virginia and the *Legislative Rules* of the Purchasing Division shall govern all rights and duties under the Contract, including without limitation the validity of this Purchase Order/Contract.
12. Any reference to automatic renewal is hereby deleted. The Contract may be renewed only upon mutual written agreement of the parties.
13. **BANKRUPTCY:** In the event the vendor/contractor files for bankruptcy protection, the State may deem this contract null and void, and terminate such contract without further order.
14. **HIPAA BUSINESS ASSOCIATE ADDENDUM:** The West Virginia State Government HIPAA Business Associate Addendum (BAA), approved by the Attorney General, and available online at the Purchasing Division's web site (<http://www.state.wv.us/admin/purchase/vrc/hipaa.htm>) is hereby made part of the agreement. Provided that, the Agency meets the definition of a Cover Entity (45 CFR §160.103) and will be disclosing Protected Health Information (45 CFR §160.103) to the vendor.
15. **WEST VIRGINIA ALCOHOL & DRUG-FREE WORKPLACE ACT:** If this Contract constitutes a public improvement construction contract as set forth in Article 1D, Chapter 21 of the West Virginia Code ("The West Virginia Alcohol and Drug-Free Workplace Act"), then the following language shall hereby become part of this Contract: "The contractor and its subcontractors shall implement and maintain a written drug-free workplace policy in compliance with the West Virginia Alcohol and Drug-Free Workplace Act, as set forth in Article 1D, Chapter 21 of the West Virginia Code. The contractor and its subcontractors shall provide a sworn statement in writing, under the penalties of perjury, that they maintain a valid drug-free work place policy in compliance with the West Virginia and Drug-Free Workplace Act. It is understood and agreed that this Contract shall be cancelled by the awarding authority if the Contractor: 1) Fails to implement its drug-free workplace policy; 2) Fails to provide information regarding implementation of the contractor's drug-free workplace policy at the request of the public authority; or 3) Provides to the public authority false information regarding the contractor's drug-free workplace policy."

INSTRUCTIONS TO BIDDERS

1. Use the quotation forms provided by the Purchasing Division.
2. **SPECIFICATIONS:** Items offered must be in compliance with the specifications. Any deviation from the specifications must be clearly indicated by the bidder. Alternates offered by the bidder as **EQUAL** to the specifications must be clearly defined. A bidder offering an alternate should attach complete specifications and literature to the bid. The Purchasing Division may waive minor deviations to specifications.
3. Complete all sections of the quotation form.
4. Unit prices shall prevail in case of discrepancy.
5. All quotations are considered F.O.B. destination unless alternate shipping terms are clearly identified in the quotation.
6. **BID SUBMISSION:** All quotations must be delivered by the bidder to the office listed below prior to the date and time of the bid opening. Failure of the bidder to deliver the quotations on time will result in bid disqualifications: Department of Administration, Purchasing Division, 2019 Washington Street East, P.O. Box 50130, Charleston, WV 25305-0130



State of West Virginia
 Department of Administration
 Purchasing Division
 2019 Washington Street East
 Post Office Box 50130
 Charleston, WV 25305-0130

Request for Quotation

RFQ NUMBER
PSH90126

PAGE
2

ADDRESS CORRESPONDENCE TO ATTENTION OF:
ROBERTA WAGNER 304-558-0067

VENDOR

RFQ COPY
 TYPE NAME/ADDRESS HERE

SHIP TO

HEALTH AND HUMAN RESOURCES
 PINECREST HOSPITAL
 105 SOUTH EISENHOWER DRIVE
 BECKLEY, WV 25801 304-256-6614

DATE PRINTED	TERMS OF SALE	SHIP VIA	F.O.B.	FREIGHT TERMS
05/13/2009				

BID OPENING DATE: 05/26/2009 BID OPENING TIME 01:30PM

LINE	QUANTITY	UOP	CAT NO	ITEM NUMBER	UNIT PRICE	AMOUNT
------	----------	-----	--------	-------------	------------	--------

VENDOR MUST CLEARLY UNDERSTAND THAT ANY VERBAL REPRESENTATION MADE OR ASSUMED TO BE MADE DURING ANY ORAL DISCUSSION HELD BETWEEN VENDOR'S REPRESENTATIVES AND ANY STATE PERSONNEL IS NOT BINDING. ONLY THE INFORMATION ISSUED IN WRITING AND ADDED TO THE SPECIFICATIONS BY AN OFFICIAL ADDENDUM IS BINDING.

.....
 SIGNATURE
 Pinnacle Electric, Inc.
 COMPANY
 6/8/09
 DATE

REV. 11/96

END OF ADDENDUM NO. 1

1001	5	EA		936-73	1,633.91	8,169.55
DIGITAL VIDEO RECORDERS PER SPECIFICATIONS						

SEE REVERSE SIDE FOR TERMS AND CONDITIONS

SIGNATURE	TELEPHONE	DATE
-----------	-----------	------

TITLE	FEIN	ADDRESS CHANGES TO BE NOTED ABOVE
-------	------	-----------------------------------

WHEN RESPONDING TO RFQ, INSERT NAME AND ADDRESS IN SPACE ABOVE LABELED 'VENDOR'



State of West Virginia
 Department of Administration
 Purchasing Division
 2019 Washington Street East
 Post Office Box 50130
 Charleston, WV 25305-0130

Request for Quotation

RFQ NUMBER
PSH90126

PAGE
1

ADDRESS CORRESPONDENCE TO ATTENTION OF
ROBERTA WAGNER 304-558-0067

RFQ COPY
 PINNACLE ELECTRIC INC
 817 19TH STREET
 PARKERSBURG WV 26101

VENDOR

HEALTH AND HUMAN RESOURCES
 PINECREST HOSPITAL
 105 SOUTH EISENHOWER DRIVE
 BECKLEY, WV 25801
 304-256-6614

SHIP TO

DATE PRINTED	TERMS OF SALE	SHIP VIA	F.O.B.	FREIGHT TERMS
05/22/2009				

BID OPENING DATE: 06/09/2009 BID OPENING TIME 01:30PM

LINE	QUANTITY	UOP	CAT NO	ITEM NUMBER	UNIT PRICE	AMOUNT
ADDENDUM #02						
THIS ADDENDUM ISSUED TO EXTEND THE BID OPENING DATE FROM 5/26/2009 TO 6/9/2009; 1:30 PM.						
REVISED BID OPENING DATE: 6/9/2009; 1:30 PM						
0001	5	EA		936-73		
DIGITAL VIDEO RECORDERS PER SPECIFICATIONS						
0002	10	EA		936-73		
UNINTERRUPTIBLE POWER SUPPLY						

SEE REVERSE SIDE FOR TERMS AND CONDITIONS

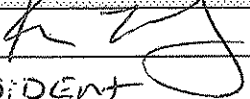
SIGNATURE 	TELEPHONE 304-991-2286	DATE 6/8/09
TITLE PRESIDENT	FEIN 26-317-2308	ADDRESS CHANGES TO BE NOTED ABOVE

WHEN RESPONDING TO RFQ, INSERT NAME AND ADDRESS IN SPACE ABOVE LABELED 'VENDOR'



State of West Virginia
 Department of Administration
 Purchasing Division
 2019 Washington Street East
 Post Office Box 50130
 Charleston, WV 25305-0130

Request for Quotation

RFQ NUMBER
PSH90126

PAGE
1

ADDRESS CORRESPONDENCE TO ATTENTION OF
ROBERTA WAGNER
304-558-0067

RFQ COPY
 TYPE NAME/ADDRESS HERE

VENDOR

|||||
PINNACLE ELECTRIC INC.
817 19TH STREET
PARKERSBURG, WV 26101

SHIP TO

HEALTH AND HUMAN RESOURCES
PINECREST HOSPITAL
105 SOUTH EISENHOWER DRIVE
BECKLEY, WV
25801 **304-256-6614**

DATE PRINTED: 05/28/2009	TERMS OF SALE	SHIP VIA	F.O.B.	FREIGHT TERMS
BID OPENING DATE: 06/09/2009		BID OPENING TIME 01:30PM		

LINE	QUANTITY	UOP	CAT NO.	ITEM NUMBER	UNIT PRICE	AMOUNT
<p>ADDENDUM NO. 3</p> <p>1. QUESTIONS AND ANSWERS ARE ATTACHED.</p> <p>2. ADDENDUM ACKNOWLEDGEMENT IS ATTACHED. THIS DOCUMENT SHOULD BE SIGNED AND RETURNED WITH YOUR BID. FAILURE TO SIGN AND RETURN MAY RESULT IN DISQUALIFICATION OF YOUR BID.</p> <p>EXHIBIT 10</p> <p>REQUISITION NO.: PSH90126</p> <p>ADDENDUM ACKNOWLEDGEMENT</p> <p>I HEREBY ACKNOWLEDGE RECEIPT OF THE FOLLOWING CHECKED ADDENDUM(S) AND HAVE MADE THE NECESSARY REVISIONS TO M PROPOSAL, PLANS AND/OR SPECIFICATION, ETC.</p> <p>ADDENDUM NO.'S:</p> <p>NO. 1 <i>[initials]</i></p> <p>NO. 2 <i>[initials]</i></p> <p>NO. 3 <i>[initials]</i></p> <p>NO. 4</p> <p>NO. 5</p> <p>I UNDERSTAND THAT FAILURE TO CONFIRM THE RECEIPT OF THE ADDENDUM(S) MAY BE CAUSE FOR REJECTION OF BIDS.</p> <p>VENDOR MUST CLEARLY UNDERSTAND THAT ANY VERBAL REPRESENTATION MADE OR ASSUMED TO BE MADE DURING ANY</p>						

SEE REVERSE SIDE FOR TERMS AND CONDITIONS

SIGNATURE: *[Signature]* TELEPHONE: **304-991-2286** DATE: **6/8/09**

FILE: **President** FEIN: **26-317-2308**

ADDRESS CHANGES TO BE NOTED ABOVE

WHEN RESPONDING TO RFQ, INSERT NAME AND ADDRESS IN ENVELOPE



State of West Virginia
 Department of Administration
 Purchasing Division
 2019 Washington Street East
 Post Office Box 50130
 Charleston, WV 25305-0130

Request for Quotation

RFQ NUMBER
 PSH90126

PAGE
 2

ADDRESS CORRESPONDENCE TO ATTENTION OF
 ROBERTA WAGNER
 304-558-0067

RFQ COPY
 TYPE NAME/ADDRESS HERE

HEALTH AND HUMAN RESOURCES
 PINECREST HOSPITAL
 105 SOUTH EISENHOWER DRIVE
 BECKLEY, WV
 25801
 304-256-6614

DATE PRINTED 05/28/2009	TERMS OF SALE	SHIP VIA	F.O.B.	FREIGHT TERMS
----------------------------	---------------	----------	--------	---------------

BID OPENING DATE: 06/09/2009 BID OPENING TIME 01:30PM

LINE	QUANTITY	UOP	CAT. NO.	ITEM NUMBER	UNIT PRICE	AMOUNT
<p>ORAL DISCUSSION HELD BETWEEN VENDOR'S REPRESENTATIVES AND ANY STATE PERSONNEL IS NOT BINDING. ONLY THE INFORMATION ISSUED IN WRITING AND ADDED TO THE SPECIFICATIONS BY AN OFFICIAL ADDENDUM IS BINDING.</p> <p>..... SIGNATURE Pinnacle Electric, Inc. COMPANY 6/8/09 DATE</p> <p>REV. 11/96</p> <p>END OF ADDENDUM NO. 3</p>						

SEE REVERSE SIDE FOR TERMS AND CONDITIONS

INATURE TELEPHONE DATE

LE FEIN ADDRESS CHANGES TO BE NOTED ABOVE

WHEN RESPONDING TO RFQ, INSERT NAME AND ADDRESS IN SPACE ABOVE LABELLED VENDOR

Pinecrest Hospital

PSH90126 – Security Cameras

Addendum – Answers to Questions as of 5/27/09

1. Question: Section 3.5.1

The Sony SPE-110 camera does not exist will need a minimum spec for required cameras.

Response: Sony SSCCD77 Ruggedized Mini-dome Color Camera with 540 Lines (Day/Night).

(<http://pro.sony.com/bbsc/ssr/cat-securitycameras/cat-cctv/product-SSCCD77/>)

Horizontal resolution: minimum 540 TV lines

2. Question: Section 5

This section is asking for serial numbers and IP address, these could only be given after equipment received and installed.

Response: This is true and this requirement should be stricken.

Line number six in the parenthesis (i.e. serial number, IP address, etc.)

3. Question: On page 10 of the bid packet, there are items listed that you are asking to be included in this project. The list starts with item 0002. I believe that item 0001 should be the DVR that is included in this project along with a part number that you are wanting.

Response: Item 0001 is listed on page 1.



State of West Virginia
 Department of Administration
 Purchasing Division
 2019 Washington Street East
 Post Office Box 50130
 Charleston, WV 25305-0130

**Request for
 Quotation**

RFQ NUMBER:
PSH90126

PAGE:
3

ADDRESS CORRESPONDENCE TO ATTENTION OF:
**ROBERTA WAGNER
 304-558-0067**

VENDOR

RFQ COPY
 TYPE NAME/ADDRESS HERE

SHIP TO

HEALTH AND HUMAN RESOURCES
 PINECREST HOSPITAL
 105 SOUTH EISENHOWER DRIVE
 BECKLEY, WV
 25801 304-256-6614

DATE PRINTED	TERMS OF SALE	SHIP VIA	F.O.B.	FREIGHT TERMS
05/13/2009				

BID OPENING DATE: **05/26/2009** BID OPENING TIME **01:30PM**

LINE	QUANTITY	UOP	CAT NO.	ITEM NUMBER	UNIT PRICE	AMOUNT
0002	10	EA		936-73 UNINTERRUPTIBLE POWER SUPPLY	333.42	3,334.20
0003	5	EA		936-73 16 CHANNEL POWER SUPPLY	290.56	1,452.80
0004	53	EA		936-73 SONY SPE-110, OR EQUAL, VANDAL PROOF DOME CAMERA	249.24	13,209.54
0005	10	EA		936-73 OUTDOOR CAMERA WITH 5-50 MM VARIFOCAL LENS	401.64	4,016.40
0006	10	EA		936-73 WEATHER PROOF HOUSING FOR OUTDOOR CAMERAS	274.74	2,747.36

SEE REVERSE SIDE FOR TERMS AND CONDITIONS

SIGNATURE	TELEPHONE	DATE
TITLE	FEIN	ADDRESS CHANGES TO BE NOTED ABOVE

WHEN RESPONDING TO RFQ, INSERT NAME AND ADDRESS IN SPACE ABOVE LABELED 'VENDOR'



State of West Virginia
 Department of Administration
 Purchasing Division
 2019 Washington Street East
 Post Office Box 50130
 Charleston, WV 25305-0130

Request for Quotation

RFQ NUMBER
PSH90126

PAGE
4

ADDRESS CORRESPONDENCE TO ATTENTION OF
ROBERTA WAGNER
304-558-0067

RFQ COPY
 TYPE NAME/ADDRESS HERE

V
E
N
D
O
R

S
H
I
P
T
O

HEALTH AND HUMAN RESOURCES
 PINECREST HOSPITAL
 105 SOUTH EISENHOWER DRIVE
 BECKLEY, WV
 25801
 304-256-6614

DATE PRINTED	TERMS OF SALE	SHIP VIA	F.O.B.	FREIGHT TERMS
05/13/2009				

BID OPENING DATE: **05/26/2009** BID OPENING TIME **01:30PM**

LINE	QUANTITY	UOP	CAT. NO.	ITEM NUMBER	UNIT PRICE	AMOUNT
0007	1	JB		936-73	0	3,575.35
MOUNTING BRACKETS, CABLE AND CABLE TERMINATIONS						
0008	1	JB		936-73	0	0
REQUIRED SOFTWARE FOR SECURITY SYSTEM						
0009	1	JB		936-73	817.21	51,484.43
LABOR COSTS						
0010	1	LS		936-73	0	0
ALL OTHER COSTS (PLEASE SPECIFY)						
***** THIS IS THE END OF RFQ PSH90126 ***** TOTAL:						87,989.63

SEE REVERSE SIDE FOR TERMS AND CONDITIONS

SIGNATURE	TELEPHONE	DATE
-----------	-----------	------

TITLE	FEIN	ADDRESS CHANGES TO BE NOTED ABOVE
-------	------	-----------------------------------

WHEN RESPONDING TO RFQ, INSERT NAME AND ADDRESS IN SPACE ABOVE LABELED 'VENDOR'

Addendum – Answers to Questions

Section 3.5.1

Question: The Sony SPE-110 camera does not exist will need a minimum spec for required cameras.

Answer: Sony SPE-26(<http://www.securitycampros.com/dome-csp-26.php>)
Horizontal resolution : minimum 480 TV lines
Minimum Illumination .01 LUX

Section 5

Question: This section is asking for serial numbers and IP address, these could only be given after equipment received and installed.

Answer: This is true and should be striked.
Line number six in the parenthesis (i.e. serial number, IP address, etc.)

Question: Thanks for returning my call. On page 10 of the bid packet, there are items listed that you are asking to be included in this project. The list starts with item 0002. I believe that item 0001 should be the DVR that is included in this project along with a part number that you are wanting.

Answer: Item 0001 is listed on page 1

End of Addendum #1

Addendum – PSH90126
May 7, 2009

Section 3.2

Do we want to specify the number of frames per second the DVR's will record?

No, we have specified the resolution and frames per second for the cameras the DVR should work with that equipment.

3.2.4 – It was asked whether the DVR backup will be automated or manual?

Prefer automated.

3.2.9 – Can the DVR run with and embedded Linux system if they are Windows compatible?

Yes, as long as the system will interface with Windows.

Section 3.5

Can we specify a lens size?

Covered this in the email.

Section 3.6

Can we specify the resolution for the outdoor cameras?

Horizontal resolution minimum: 480 TV Lines
Minimum Illumination of .01 LUX

It was recommended that we use different size lens at different areas so that we get the best view.

Miscellaneous Questions

Can we provide each of the vendors that was present at the pre-bid meeting a copy of the sign in sheet? Yes – This will be done by the Purchasing Division.

7

What hours will vendors be allowed to work in the facility? No earlier than 7:00 a.m. and no later than 5:00 p.m., Monday thru Friday. If work needs to occur over the weekend, it would need to be coordinated with Hospital Administration.

It was asked if we had a drawing that shows the actual square footage of the facility. At this time, we are unable to locate anything that shows square footage.

Request for Proposal No.

SIGN IN SHEET

PLEASE PRINT

Page 1 of 1
Date: 5/5/09

PLEASE BE SURE TO PRINT LEGIBLY - IF POSSIBLE, LEAVE A BUSINESS CARD

FIRM & REPRESENTATIVE NAME

MAILING ADDRESS

TELEPHONE & FAX NUMBERS

Company:	<u>Bluestone Electric</u>	<u>Po Box 575</u>	PHONE <u>304 252 6102</u>
Rep:	<u>Kevin Turner</u>	<u>Beaumont WV 25813</u>	TOLL FREE
Email Address:	<u>bluestoneelectric@suddenlink.net</u>		FAX <u>304 255 6240</u>
Company:	<u>Hughes Supply Co.</u>	<u>300 Laurel Acres drive</u>	PHONE <u>304 252 1918</u>
Rep:	<u>Steve Dinkler</u>	<u>Beaumont WV 25801</u>	TOLL FREE
Email Address:	<u>stevend@hscindustrial.com</u>		FAX <u>304 252 6411</u>
Company:	<u>Simpson Technical Services</u>	<u>519 Highland Ave.</u>	PHONE <u>304 437 1913</u>
Rep:	<u>Mark Simpson</u>	<u>200 W. Main St. 25805</u>	TOLL FREE
Email Address:	<u>TRSMWS@Simpson.com</u>		FAX <u>304 744 5829</u>
Company:			PHONE
Rep:			TOLL FREE
Email Address:			FAX
Company:			PHONE
Rep:			TOLL FREE
Email Address:			FAX

RECEIVED
MAY 13 2009
DHIR PURCHASING

SIGN IN SHEET

PLEASE PRINT

Page 5 of 10
Date: 5/5/09

Request for Proposal No. _____

PLEASE BE SURE TO PRINT LEGIBLY - IF POSSIBLE, LEAVE A BUSINESS CARD

TELEPHONE & FAX NUMBERS

FIRM & REPRESENTATIVE NAME	MAILING ADDRESS	TELEPHONE & FAX NUMBERS
Company: <u>Simplex Grinnell</u> Rep: <u>JEFF WEST</u>	<u>2500 7TH AVE SUITE 102</u> <u>CHAS. WY 25302</u>	PHONE (304) <u>206-0012</u> TOLL FREE <u>800-999-0512</u> FAX <u>304 746-4589</u>
Email Address: <u>simplexgrinnell.com</u>		
Company: <u>Moustan Same Business Automation</u> Rep: <u>CRIS CAHILL</u>	<u>6444 Sissonville Rd</u> <u>Sissonville, WV 25330</u>	PHONE (304) <u>941-9331</u> TOLL FREE FAX (304) <u>984-0124</u>
Email Address: <u>ceaster@msbautomation.com</u>		
Company: <u>Pinnacle Electric, Inc</u> Rep: <u>KEVAN MERRILL</u>		PHONE <u>504-991-2286</u> TOLL FREE FAX
Email Address: <u>PinnacleElectric.com internet</u>		
Company: <u>Cox Security Services</u> Rep: <u>DAVID VINCENT / Morris Sumner</u>	<u>Po Box 1051</u> <u>Bluefield, WV 26010</u>	PHONE <u>304-255-4211</u> TOLL FREE <u>877-334-4210</u> FAX <u>304-323-2310</u>
Email Address: <u>vincent@coxsecurity.com</u>		
Company: <u>Improvements Unlimited</u> Rep: <u>Bill Barram</u>	<u>318 East Hoose Rd</u> <u>Princeton WV 24740</u>	PHONE <u>304-487-1256</u> TOLL FREE <u>866-807-3473</u> FAX <u>304-487-5487</u>
Email Address: _____		

RECEIVED
MAY 13 2009

SIGN IN SHEET

Request for Proposal No. _____

PLEASE PRINT

Page _____ of _____
Date: 5/5/09

PLEASE BE SURE TO PRINT LEGIBLY - IF POSSIBLE, LEAVE A BUSINESS CARD

FIRM & REPRESENTATIVE NAME

MAILING ADDRESS

TELEPHONE & FAX NUMBERS

Company:	ADVANCED COMMUNICATION Co	P.O. Box 6650	PHONE 304-233-3000
Rep:	Roy Kayhurst	2744 Eoff Street	TOLL FREE 800-336-4933
Email Address:	KAYHURST@ACCENTRAK.COM	WHEELING, WV. 26003	FAX 304-233-9666
Company:	ADVANCED ELECTRIC	3960 Chimney Dr	PHONE 304-935-1107
Rep:	Chad Morris	CHARLESTON, WV 25302	TOLL FREE
Email Address:	AEDATACOMM@VERIZON.COM		FAX 304-345-5534
Company:	Phillips Machine Service dba Phillips Technologies	367 George St	PHONE 204-253-5481
Rep:	Kevin Veedward	Beckley, WV 25801	TOLL FREE
Email Address:	Veedward@phillipsmls.com		FAX 204-253-6148
Company:			PHONE
Rep:			TOLL
Email Address:			FREE
Company:			FAX
Rep:			PHONE
Email Address:			TOLL
			FREE
			FAX

RECEIVED
 MAY 13 2009
 DPHR
 PURCHASING

SIGN IN SHEET

PLEASE PRINT

Page 5 of 5
Date: 5/5/09

Request for Proposal No.

PLEASE BE SURE TO PRINT LEGIBLY. IF POSSIBLE, LEAVE A BUSINESS CARD

FIRM & REPRESENTATIVE NAME

MAILING ADDRESS

TELEPHONE & FAX NUMBERS

Company:	SL Marketing	956 NOKAMUDY DR	PHONE 412-926-7125
Rep:	JACK MEDAVAL	NEW KENSINGTON PA 15065	TOLL FREE
Email Address:	JACKMED@SL-MARKETING.COM		FAX
Company:	Professional Electric	P.O. Box 401	PHONE 304-640-2681
Rep:	Joe Hyper	Highway 2585V	TOLL FREE
Email Address:	joehyper@earthlink.net		FAX
Company:	NeusTech Systems	420 16th Street	PHONE 304-766-0000
Rep:	Andrew Ramsey	Dunbar, WV 25064	TOLL FREE
Email Address:	Aramsey@neustechwv.com		FAX 304-766-0003
Company:	Louis Security Camera Systems LLC	102 38th ST SE.	PHONE 304-925-0338
Rep:	Alan E Lang	Charleston WV 25304	TOLL FREE
Email Address:	langa@sls-solutions.net		FAX 304-925-0338
Company:	Miller Communications Inc	ONE WIRELESS WAY SUITE 100	PHONE 304-863-8595
Rep:	Harold Smith	PARKERSBURG, WV 26101	TOLL FREE
Email Address:	Harold@MillerComm.com		FAX 304-863-3786

RECEIVED
MAY 13 2009
DHHR
PURCHASING

SIGN IN SHEET

Request for Proposal No.

PLEASE PRINT

Date:

Page 1 of 1
5/5/09

PLEASE BE SURE TO PRINT LEGIBLY - IF POSSIBLE, LEAVE A BUSINESS CARD

FIRM & REPRESENTATIVE NAME

MAILING ADDRESS

TELEPHONE & FAX NUMBERS

Company:	<u>EASTERN ELECTRIC, LLC</u>	<u>P.O. Box 92</u>	PHONE <u>304-872-4868</u>
Rep:	<u>JOHN J. KUHN</u>	<u>MT. NEBO, WV</u>	TOLL FREE
Email Address:	<u>JKUHN@EASTERNELECTRIC.LLC.COM</u>	<u>26679</u>	FAX <u>304-872-2634</u>
Company:			PHONE
Rep:			TOLL FREE
Email Address:			FAX
Company:			PHONE
Rep:			TOLL FREE
Email Address:			FAX
Company:			PHONE
Rep:			TOLL FREE
Email Address:			FAX

RECEIVED

MAY 13 2009

DHHR
DEPARTMENT OF HEALTH & HUMAN RESOURCES

SIGN IN SHEET

Request for Proposal No.

PLEASE PRINT

Page 5 of 10
Date: 5/5/09

PLEASE BE SURE TO PRINT LEGIBLY - IF POSSIBLE, LEAVE A BUSINESS CARD

FIRM & REPRESENTATIVE NAME

MAILING ADDRESS

TELEPHONE & FAX NUMBERS

Company:	Advanced Alarm Technologies	PO Box 4368	PHONE 304-422-4387
Rep:	Earl Meyer	Parkersburg W.V 26104	TOLL FREE
Email Address:			FAX 304-422-4387
Company:	KVA Telephone Security	211 East Main St	PHONE 304-465-0400
Rep:	Scott Stoffer	Oak Hill WV 25309	TOLL FREE 304-465-5837
Email Address:	SSstoffer@kva.com		FAX
Company:	Advanced Network Systems	801 S College Ave	PHONE 276-322-1555
Rep:	Brian Leedy	Blufffield, VA 24605	TOLL FREE
Email Address:	bleedy@getadvanced.net		FAX 276-322-1532
Company:	Verizon	827 Fairmont Rd.	PHONE 304-284-0504
Rep:	Lawrence W. Host	Wes-mon Center, Suite 204	TOLL FREE
Email Address:	lawrence.host@verizonbusiness.com	Morgantown, WV 26501	FAX 304-284-0500
Company:			PHONE
Rep:			TOLL
Email Address:			FREE
			FAX

RECEIVED

MAY 13 2009

Printing
Finishing

SIGN IN SHEET

Request for Proposal No.

PLEASE PRINT

Page 5/5 of 109
Date: 5/5/09

PLEASE BE SURE TO PRINT LEGIBLY - IF POSSIBLE, LEAVE A BUSINESS CARD

FIRM & REPRESENTATIVE NAME

MAILING ADDRESS

TELEPHONE & FAX NUMBERS

Company:	INTERTELL SECURITY	3498 KENNESAW DR	PHONE	724-742-4900
Rep:	MARK STEWARD		TOLL FREE	
Email Address:	MSTEWARD@ITS-SECURE.COM		FAX	724-742-4920
Company:	GRAYBAR	1010 BUNKS ST	PHONE	301-344-2371
Rep:	KEVIN HYPES	CHARLESTON WV 25301	TOLL FREE	
Email Address:	Kevin.hypes@graybar.com		FAX	304-344-0324
Company:			PHONE	
Rep:			TOLL FREE	
Email Address:			FAX	
Company:			PHONE	
Rep:			TOLL FREE	
Email Address:			FAX	

RECEIVED
MAY 13 2009
DHHH

Request for Proposal No.

SIGN IN SHEET

PLEASE PRINT

PSH92126 ?

Page 1 of 1
Date: 5/5/09

PLEASE BE SURE TO PRINT LEGIBLY. IF POSSIBLE, LEAVE A BUSINESS CARD

FIRM & REPRESENTATIVE NAME

MAILING ADDRESS

TELEPHONE & FAX NUMBERS

Company:	Seure US	330 Scott Ave	PHONE 304-291-2994
Rep:	Sean Arthur	Markstrom W 26528	TOLL FREE 800-653-2994
Email Address:	seathur@seure.com		FAX 304-294-9678
Company:			PHONE
Rep:			TOLL
Email Address:			FREE
Company:			FAX
Rep:			PHONE
Email Address:			TOLL
Company:			FREE
Rep:			FAX
Email Address:			PHONE
Company:			TOLL
Rep:			FREE
Email Address:			FAX

ONISVCHDID VW

91:21M 31 YW 6002

RECEIVED

RECEIVED
MAY 13 2009
DHR



State of West Virginia
 Department of Administration
 Purchasing Division
 2019 Washington Street East
 Post Office Box 50130
 Charleston, WV 25305-0130

**Request for
 Quotation**

RFQ NUMBER
PSH90126

PAGE
1

ADDRESS CORRESPONDENCE TO ATTENTION OF
**ROBERTA WAGNER
 304-558-0067**

PROPERTY

RFQ COPY
 TYPE NAME/ADDRESS HERE

SHIP TO

**HEALTH AND HUMAN RESOURCES
 PINECREST HOSPITAL
 105 SOUTH EISENHOWER DRIVE
 BECKLEY, WV
 25801 304-256-6614**

DATE PRINTED	TERMS OF SALE	SHIP VIA	FOB	FREIGHT TERMS
04/16/2009				

BID OPENING DATE: **05/26/2009** BID OPENING TIME **01:30PM**

LINE	QUANTITY	UQP	CAT NO	ITEM NUMBER	UNIT PRICE	AMOUNT
0001	5	EA	936-73	DIGITAL VIDEO RECORDERS PER SPECIFICATIONS	1,633.91	8,169.55
<p>***** DRUG FREE WORKPLACE CONFORMANCE AFFIDAVIT AND THE BID BOND MUST BE RECEIVED WITH THE BID SUBMISSION. ***** MANDATORY PRE-BID MEETING IS SCHEDULED FOR 5/5/9 AT 11:00 AM AT PINECREST HOSPITAL, 105 S. EISENHOWER DRIVE BECKLEY, WV, ROOM #B-109. *****</p> <p>TO PROVIDE ALL LABOR, MATERIALS, EQUIPMENT AND OTHER INCIDENTALS RELATED TO THE INSTALLATION OF A NEW SECURITY CAMERA SYSTEM TO BE INSTALLED AT PINECREST HOSPITAL LOCATED AT 105 S. EISENHOWER DRIVE, BECKLEY, WV, 25801, PER THE ATTACHED SPECIFICATIONS.</p> <p>THIS IS A REBID OF PSH90063. INQUIRIES: WRITTEN QUESTIONS SHALL BE ACCEPTED THROUGH CLOSE OF BUSINESS ON 5/7/2009. QUESTIONS MAY BE SENT VIA USPS, FAX, COURIER OR E-MAIL. IN ORDER TO ASSURE NO VENDOR RECEIVES AN UNFAIR ADVANTAGE, NO SUBSTANTIVE QUESTIONS WILL BE ANSWERED ORALLY. IF POSSIBLE, E-MAIL QUESTIONS ARE PREFERRED. ADDRESS INQUIRIES TO: ROBERTA WAGNER</p>						

SEE REVERSE SIDE FOR TERMS AND CONDITIONS

SIGNATURE TELEPHONE **304-991-2286** DATE **6/8/09**
 TITLE **President** FIRM **26-3172308** ADDRESS CHANGES TO BE NOTED ABOVE

WHEN RESPONDING TO RFQ, INSERT NAME AND ADDRESS IN SPACE ABOVE LABELED 'VENDOR'

GENERAL TERMS & CONDITIONS
REQUEST FOR QUOTATION (RFQ) AND REQUEST FOR PROPOSAL (RFP)

1. Awards will be made in the best interest of the State of West Virginia.
2. The State may accept or reject in part, or in whole, any bid.
3. All quotations are governed by the *West Virginia Code* and the *Legislative Rules* of the Purchasing Division.
4. Prior to any award, the apparent successful vendor must be properly registered with the Purchasing Division and have paid the required \$125 fee.
5. All services performed or goods delivered under State Purchase Order/Contracts are to be continued for the term of the Purchase Order/Contracts, contingent upon funds being appropriated by the Legislature or otherwise being made available. In the event funds are not appropriated or otherwise available for these services or goods, this Purchase Order/Contract becomes void and of no effect after June 30.
6. Payment may only be made after the delivery and acceptance of goods or services.
7. Interest may be paid for late payment in accordance with the *West Virginia Code*.
8. Vendor preference will be granted upon written request in accordance with the *West Virginia Code*.
9. The State of West Virginia is exempt from federal and state taxes and will not pay or reimburse such taxes.
10. The Director of Purchasing may cancel any Purchase Order/Contract upon 30 days written notice to the seller.
11. The laws of the State of West Virginia and the *Legislative Rules* of the Purchasing Division shall govern all rights and duties under the Contract, including without limitation the validity of this Purchase Order/Contract.
12. Any reference to automatic renewal is hereby deleted. The Contract may be renewed only upon mutual written agreement of the parties.
13. **BANKRUPTCY:** In the event the vendor/contractor files for bankruptcy protection, this Contract may be deemed null and void, and terminated without further order.
14. **HIPAA BUSINESS ASSOCIATE ADDENDUM:** The West Virginia State Government HIPAA Business Associate Addendum (BAA), approved by the Attorney General, and available online at the Purchasing Division's web site (<http://www.state.wv.us/admin/purchase/vrc/hipaa.htm>) is hereby made part of the agreement. Provided that, the Agency meets the definition of a Cover Entity (45 CFR §160.103) and will be disclosing Protected Health Information (45 CFR §160.103) to the vendor.
15. **WEST VIRGINIA ALCOHOL & DRUG-FREE WORKPLACE ACT:** If this Contract constitutes a public improvement construction contract as set forth in Article 1D, Chapter 21 of the West Virginia Code ("The West Virginia Alcohol and Drug-Free Workplace Act"), then the following language shall hereby become part of this Contract: "The contractor and its subcontractors shall implement and maintain a written drug-free workplace policy in compliance with the West Virginia Alcohol and Drug-Free Workplace Act, as set forth in Article 1D, Chapter 21 of the West Virginia Code. The contractor and its subcontractors shall provide a sworn statement in writing, under the penalties of perjury, that they maintain a valid drug-free work place policy in compliance with the West Virginia and Drug-Free Workplace Act. It is understood and agreed that this Contract shall be cancelled by the awarding authority if the Contractor: 1) Fails to implement its drug-free workplace policy; 2) Fails to provide information regarding implementation of the contractor's drug-free workplace policy at the request of the public authority; or 3) Provides to the public authority false information regarding the contractor's drug-free workplace policy."

INSTRUCTIONS TO BIDDERS

1. Use the quotation forms provided by the Purchasing Division.
2. **SPECIFICATIONS:** Items offered must be in compliance with the specifications. Any deviation from the specifications must be clearly indicated by the bidder. Alternates offered by the bidder as **EQUAL** to the specifications must be clearly defined. A bidder offering an alternate should attach complete specifications and literature to the bid. The Purchasing Division may waive minor deviations to specifications.
3. Complete all sections of the quotation form.
4. Unit prices shall prevail in case of discrepancy.
5. All quotations are considered F.O.B. destination unless alternate shipping terms are clearly identified in the quotation.
6. **BID SUBMISSION:** All quotations must be delivered by the bidder to the office listed below prior to the date and time of the bid opening. Failure of the bidder to deliver the quotations on time will result in bid disqualifications: Department of Administration, Purchasing Division, 2019 Washington Street East, P.O. Box 50130, Charleston, WV 25305-0130



State of West Virginia
 Department of Administration
 Purchasing Division
 2019 Washington Street East
 Post Office Box 50130
 Charleston, WV 25305-0130

**Request for
 Quotation**

RFQ NUMBER
PSH90126

PAGE
2

ADDRESS CORRESPONDENCE TO ATTENTION OF
**ROBERTA WAGNER
 304-558-0067**

RFQ COPY

TYPE NAME/ADDRESS HERE

VENDOR

**HEALTH AND HUMAN RESOURCES
 PINECREST HOSPITAL
 105 SOUTH EISENHOWER DRIVE
 BECKLEY, WV
 25801 304-256-6614**

DATE PRINTED	TERMS OF SALE	SHIP VIA	FOB	FREIGHT TERMS
04/16/2009				

BID OPENING DATE: **05/26/2009** BID OPENING TIME: **01:30PM**

LINE	QUANTITY	UOP	CAT NO	ITEM NUMBER	UNIT PRICE	AMOUNT
<p>DEPARTMENT OF ADMINISTRATION PURCHASING DIVISION 2019 WASHINGTON STREET, EAST CHARLESTON, WV 25311</p> <p>FAX: 304-558-4112 E-MAIL: ROBERTA.A.WAGNER@WV.GOV</p> <p>THE MODEL/BRAND/SPECIFICATIONS NAMED HEREIN ESTABLISH THE ACCEPTABLE LEVEL OF QUALITY ONLY AND ARE NOT INTENDED TO REFLECT A PREFERENCE OR FAVOR ANY PARTICULAR BRAND OR VENDOR. VENDORS WHO ARE BIDDING ALTERNATES SHOULD SO STATE AND INCLUDE PERTINENT LITERATURE AND SPECIFICATIONS. FAILURE TO PROVIDE INFORMATION FOR ANY ALTERNATES MAY BE GROUNDS FOR REJECTION OF THE BID. THE STATE RESERVES THE RIGHT TO WAIVE MINOR IRREGULARITIES IN BIDS OR SPECIFICATIONS IN ACCORDANCE WITH SECTION 148-1-4 (F) OF THE WEST VIRGINIA LEGISLATIVE RULES AND REGULATIONS.</p> <p>EXHIBIT 5</p> <p>WEST VIRGINIA CODE 21-1D-5 PROVIDES THAT: ANY SOLICITATION FOR A PUBLIC IMPROVEMENT CONSTRUCTION CONTRACT REQUIRES EACH VENDOR THAT SUBMITS A BID FOR THE WORK TO SUBMIT AT THE SAME TIME AN AFFIDAVIT OF COMPLIANCE WITH THE BID. THE ENCLOSED PURCHASING AFFIDAVIT MUST BE SIGNED AND SUBMITTED WITH THE BID AS EVIDENCE OF THE VENDOR'S COMPLIANCE WITH THE PROVISIONS OF ARTICLE 1D, CHAPTER 21 OF THE WEST VIRGINIA CODE. FAILURE TO SUBMIT THE SIGNED PURCHASING AFFIDAVIT WITH THE BID SHALL RESULT IN DISQUALIFICATION OF SUCH BID.</p> <p>NOTICE TO PROCEED: THIS CONTRACT IS TO BE PERFORMED</p>						

SEE REVERSE SIDE FOR TERMS AND CONDITIONS

SIGNATURE	TELEPHONE	DATE
TITLE	FEIN	ADDRESS CHANGES TO BE NOTED ABOVE

WHEN RESPONDING TO RFQ, INSERT NAME AND ADDRESS IN SPACE ABOVE LABELED 'VENDOR'



State of West Virginia
 Department of Administration
 Purchasing Division
 2019 Washington Street East
 Post Office Box 50130
 Charleston, WV 25305-0130

**Request for
 Quotation**

RFG NUMBER
PSH90126

PAGE
3

ADDRESS CORRESPONDENCE TO ATTENTION OF
**ROBERTA WAGNER
 304-558-0067**

RFQ COPY
 TYPE NAME/ADDRESS HERE

HEALTH AND HUMAN RESOURCES
 PINECREST HOSPITAL
 105 SOUTH EISENHOWER DRIVE
 BECKLEY, WV
 25801 304-256-6614

DATE PRINTED	TERMS OF SALE	SHIP VIA	FOB	FREIGHT TERMS
04/16/2009				

BID OPENING DATE: **05/26/2009** BID OPENING TIME **01:30PM**

LINE	QUANTITY	UOP	CAT. NO.	ITEM NUMBER	UNIT PRICE	AMOUNT
<p>WITHIN 120 CALENDAR DAYS AFTER THE NOTICE TO PROCEED IS RECEIVED.</p> <p>CANCELLATION: THE DIRECTOR OF PURCHASING RESERVES THE RIGHT TO CANCEL THIS CONTRACT IMMEDIATELY UPON WRITTEN NOTICE TO THE VENDOR IF THE MATERIALS OR WORKMANSHIP SUPPLIED ARE OF AN INFERIOR QUALITY OR DO NOT CONFORM WITH THE SPECIFICATIONS OF THE BID AND CONTRACT HERE IN.</p> <p>WAGE RATES: THE CONTRACTOR OR SUBCONTRACTOR SHALL PAY THE HIGHER OF THE U.S. DEPARTMENT OF LABOR MINIMUM WAGE RATES AS ESTABLISHED FOR RALEIGH COUNTY, PURSUANT TO WEST VIRGINIA CODE 21-5A, ET, SEQ. (PREVAILING WAGE RATES APPLY TO THIS PROJECT)</p> <p>ARBITRATION: ANY REFERENCES MADE TO ARBITRATION OR INTEREST FOR PAYMENTS DUE (EXCEPT FOR ANY INTEREST REQUIRED BY STATE LAW) CONTAINED IN THIS CONTRACT OR IN ANY AMERICAN INSTITUTE OF ARCHITECTS DOCUMENTS PERTAINING TO THIS CONTRACT ARE HEREBY DELETED.</p> <p>WORKERS' COMPENSATION: VENDOR IS REQUIRED TO PROVIDE A CERTIFICATE FROM WORKERS' COMPENSATION IF SUCCESSFUL.</p> <p>ALL OF THE ITEMS CHECKED BELOW WILL BE A REQUIREMENT OF THIS CONTRACT:</p> <p>(XX) INSURANCE: SUCCESSFUL VENDOR SHALL FURNISH PROOF OF COMMERCIAL GENERAL LIABILITY INSURANCE PRIOR TO ISSUANCE OF CONTRACT. UNLESS OTHERWISE SPECIFIED IN THE BID DOCUMENTS, THE MINIMUM AMOUNT OF INSURANCE COVERAGE REQUIRED IS \$250,000.</p>						

SEE REVERSE SIDE FOR TERMS AND CONDITIONS

SIGNATURE	TELEPHONE	DATE
TITLE	FEIN	ADDRESS CHANGES TO BE NOTED ABOVE

WHEN RESPONDING TO RFQ, INSERT NAME AND ADDRESS IN SPACE ABOVE LABELED 'VENDOR'



State of West Virginia
 Department of Administration
 Purchasing Division
 2019 Washington Street East
 Post Office Box 50130
 Charleston, WV 25305-0130

Request for
 Quotation

RFQ NUMBER
 PSH90126

PAGE
 4

ADDRESS CORRESPONDENCE TO ATTENTION OF
 ROBERTA WAGNER
 304-558-0067

VENDOR

RFQ COPY
 TYPE NAME/ADDRESS HERE

VENDOR

HEALTH AND HUMAN RESOURCES
 PINECREST HOSPITAL
 105 SOUTH EISENHOWER DRIVE
 BECKLEY, WV
 25801 304-256-6614

DATE PRINTED	TERMS OF SALE	SHIP VIA	FOB	FREIGHT TERMS
04/16/2009				

BID OPENING DATE: 05/26/2009 BID OPENING TIME 01:30PM

LINE	QUANTITY	UOP	CAT. NO.	ITEM NUMBER	UNIT PRICE	AMOUNT
<p>) BUILDERS RISK INSURANCE: SUCCESSFUL VENDOR SHALL FURNISH PROOF OF BUILDERS RISK - ALL RISK INSURANCE IN AN AMOUNT EQUAL TO 100% OF THE AMOUNT OF THE CONTRACT.</p> <p>XX) BONDS: FIVE PERCENT (5%) OF THE TOTAL AMOUNT OF THE BID PAYABLE TO THE STATE OF WEST VIRGINIA, SHALL B SUBMITTED WITH EACH BID AS A BID BOND. THE SUCCESSFUL BIDDER SHALL ALSO FURNISH A PERFORMANCE BOND AND LABOR/MATERIAL BOND FOR 100% OF THE AMOUNT OF THE CONTRACT. BONDS MAY BE PROVIDED IN THE FORM OF A CERTIFIED CHECK, IRREVOCABLE LETTER OF CREDIT, OR BOND FURNISHED BY A SOLVENT SURETY COMPANY AUTHORIZED TO DO BUSINESS IN TH STATE OF WEST VIRGINIA. A LETTER OF CREDIT SUBMITTED IN LIEU OF A BOND WILL ONLY BE ALLOWED FOR PROJECTS UNDER \$100,000. PERSONAL OR BUSINESS CHECKS ARE NOT ACCEPABLE IN LIEU OF THE 5% BID BOND, PERFORMANCE BOND, OR LABOR AND MATERIAL BOND.</p> <p>) MAINTENANCE BOND: A TWO (2) YEAR MAINTENANCE BOND COVERING THE ROOFING SYSTEM WILL BE A REQUIREMENT OF THE SUCCESSFUL VENDOR.</p> <p>REV. 11/00</p> <p>EXHIBIT 7</p> <p>DOMESTIC ALUMINUM, GLASS & STEEL IN PUBLIC WORKS PROJECTS</p> <p>IN ACCORDANCE WITH WEST VIRGINIA CODE 5-19-1 ET., SEQ., EVERY CONTRACT FOR CONSTRUCTION, RECONSTRUCTION, ALTERATION, REPAIR, IMPROVEMENT OR MAINTENANCE OF PUBLIC WORKS, WHERE THE COST IS MORE THAN \$50,000 AND, IN THE CASE OF STEEL ONLY, WHERE THE COST OF STEEL IS MORE THAN \$50,000 OR WHERE MORE THAN 10,000 POUNDS OF</p>						

SEE REVERSE SIDE FOR TERMS AND CONDITIONS

SIGNATURE	TELEPHONE	DATE
TITLE	FEIN	ADDRESS CHANGES TO BE NOTED ABOVE

WHEN RESPONDING TO RFQ, INSERT NAME AND ADDRESS IN SPACE ABOVE LABELED 'VENDOR'



State of West Virginia
 Department of Administration
 Purchasing Division
 2019 Washington Street East
 Post Office Box 50130
 Charleston, WV 25305-0130

**Request for
 Quotation**

RFO NUMBER
 PSH90126

PAGE
 5

ADDRESS CORRESPONDENCE TO ATTENTION OF
 ROBERTA WAGNER
 304-558-0067

BIDDING

RFO COPY
 TYPE NAME/ADDRESS HERE

SHIP TO

HEALTH AND HUMAN RESOURCES
 PINECREST HOSPITAL
 105 SOUTH EISENHOWER DRIVE
 BECKLEY, WV
 25801 304-256-6614

DATE PRINTED	TERMS OF SALE	SHIP VIA	F.O.B.	FREIGHT TERMS
04/26/2009				

BID OPENING DATE: 05/26/2009 BID OPENING TIME 01:30PM

LINE	QUANTITY	UOP	CAT NO	ITEM NUMBER	UNIT PRICE	AMOUNT
<p>STEEL ARE REQUIRED, THE STATE WILL ACCEPT ONLY ALUMINUM GLASS, OR STEEL PRODUCTS PRODUCED IN THE UNITED STATES. IN ADDITION, ITEMS OF MACHINERY OR EQUIPMENT PURCHASED FOR USE AT THE SITE OF PUBLIC WORKS SHALL BE MADE OF DOMESTIC ALUMINUM, GLASS OR STEEL, UNLESS THE COST OF THE PRODUCT IS LESS THAN \$50,000 OR LESS THAN 10,000 POUNDS OF STEEL ARE USED IN PUBLIC WORKS PROJECTS.</p> <p>FOREIGN MADE ALUMINUM, GLASS OR STEEL PRODUCTS MAY BE ACCEPTED ONLY IF THE COST OF DOMESTIC PRODUCTS IS FOUND TO BE UNREASONABLE. SUCH COST IS UNREASONABLE IF IT IS 20% OR MORE HIGHER THAN THE BID PRICE FOR FOREIGN MADE PRODUCTS. IF THE DOMESTIC ALUMINUM, GLASS OR STEEL PRODUCTS TO BE SUPPLIED OR PRODUCED IN A "SUBSTANTIAL LABOR SURPLUS AREA", AS DEFINED BY THE UNITED STATES DEPARTMENT OF LABOR, FOREIGN PRODUCTS MAY BE SUPPLIED ONLY IF DOMESTIC PRODUCTS ARE 30% OR MORE HIGHER IN PRICE THAN THE FOREIGN MADE PRODUCTS.</p> <p>IF, PRIOR TO THE AWARD OF A CONTRACT UNDER THE ABOVE PROVISIONS, THE SPENDING OFFICER OF THE SPENDING UNIT DETERMINES THAT THERE EXISTS A BID FOR LIKE FOREIGN ALUMINUM, GLASS OR STEEL THAT IS REASONABLE AND LOWER THAN THE LOWEST BID DOMESTIC PRODUCTS, THE SPENDING OFFICE MAY REQUEST, IN WRITING, A REEVALUATION AND REDUCTION IN THE LOWEST BID FOR SUCH DOMESTIC PRODUCTS. ALL VENDORS MUST INDICATE IN THEIR BID IF THEY ARE SUPPLYING FOREIGN ALUMINUM, GLASS OR STEEL.</p> <p>REV. 3/88</p> <p>EXHIBIT 9</p> <p>NOTICE FOR ISSUANCE & ACKNOWLEDGEMENT OF CONSTRUCTION PROJECT ADDENDA</p>						

SEE REVERSE SIDE FOR TERMS AND CONDITIONS

SIGNATURE	TELEPHONE	DATE
-----------	-----------	------

TITLE	FEIN	ADDRESS CHANGES TO BE NOTED ABOVE
-------	------	-----------------------------------

WHEN RESPONDING TO RFO, INSERT NAME AND ADDRESS IN SPACE ABOVE LABELED 'VENDOR'



State of West Virginia
 Department of Administration
 Purchasing Division
 2019 Washington Street East
 Post Office Box 50130
 Charleston, WV 25305-0130

**Request for
 Quotation**

RFO NUMBER
 PSH90126

PAGE
 6

ADDRESS CORRESPONDENCE TO ATTENTION OF
 ROBERTA WAGNER
 304-558-0067

RFO COPY
 TYPE NAME/ADDRESS HERE

HEALTH AND HUMAN RESOURCES
 PINECREST HOSPITAL
 105 SOUTH EISENHOWER DRIVE
 BECKLEY, WV
 25801 304-256-6614

DATE PRINTED	TERMS OF SALE	SHIP VIA	F.O.B.	FREIGHT TERMS
04/16/2009				

BID OPENING DATE: 05/26/2009 BID OPENING TIME 01:30PM

LINE	QUANTITY	UOF	QAT NO	ITEM NUMBER	UNIT PRICE	AMOUNT
<p>THE ARCHITECT/ENGINEER AND/OR AGENCY SHALL BE REQUIRED TO ABIDE BY THE FOLLOWING SCHEDULE IN ISSUING CONSTRUCTION PROJECT ADDENDA FOR STATE AGENCIES:</p> <p>(1) THE ARCHITECT/ENGINEER SHALL PREPARE THE ADDENDUM AND A LIST OF ALL PARTIES THAT HAVE PROCURED DRAWINGS AND SPECIFICATIONS FOR THE PROJECT. THE ADDENDUM AND LIST SHALL BE FORWARDED TO THE BUYER IN THE STATE PURCHASING DIVISION. THE ARCHITECT/ENGINEER SHALL ALSO SEND A COPY OF THE ADDENDUM TO THE STATE AGENCY FOR WHICH THE CONTRACT IS ISSUED.</p> <p>(2) THE BUYER SHALL SEND THE ADDENDUM TO ALL INTERESTED PARTIES AND, IF NECESSARY, EXTEND THE BID OPENING DATE. ANY ADDENDUM SHOULD BE RECEIVED BY THE BUYER WITHIN FOURTEEN (14) DAYS PRIOR TO THE BID OPENING DATE.</p> <p>(3) ALL ADDENDA SHOULD BE FORMALLY ACKNOWLEDGED BY ALL BIDDERS AND SUBMITTED TO THE STATE PURCHASING DIVISION. THE SAME RULES AND REGULATIONS THAT APPLY TO THE ORIGINAL BIDDING DOCUMENT SHALL ALSO APPLY TO AN ADDENDUM DOCUMENT. THE ONLY EXCEPTION MAY BE FOR AN ADDENDUM THAT IS ISSUED FOR THE SOLE PURPOSE OF CHANGING A BID OPENING TIME AND/OR DATE.</p> <p>REV. 11/96</p> <p>EXHIBIT 10</p> <p>ADDENDUM ACKNOWLEDGEMENT</p> <p>I HEREBY ACKNOWLEDGE RECEIPT OF THE FOLLOWING CHECKED</p>						

SIGNATURE _____ TELEPHONE _____ DATE _____

TITLE _____ FEIN _____ ADDRESS CHANGES TO BE NOTED ABOVE

WHEN RESPONDING TO RFO, INSERT NAME AND ADDRESS IN SPACE ABOVE LABELED 'VENDOR'



State of West Virginia
 Department of Administration
 Purchasing Division
 2019 Washington Street East
 Post Office Box 50130
 Charleston, WV 25305-0130

**Request for
 Quotation**

RFQ NUMBER
 PSH90126

PAGE
 7

ADDRESS CORRESPONDENCE TO ATTENTION OF
 ROBERTA WAGNER
 304-558-0067

VENDOR

RFQ COPY
 TYPE NAME/ADDRESS HERE

SHIP TO

HEALTH AND HUMAN RESOURCES
 PINECREST HOSPITAL
 105 SOUTH EISENHOWER DRIVE
 BECKLEY, WV 25801 304-256-6614

DATE PRINTED	TERMS OF SALE	SHIP VIA	FOB	FREIGHT TERMS
04/16/2009				

BID OPENING DATE: 05/26/2009 BID OPENING TIME: 01:30PM

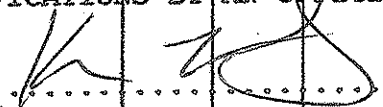
LINE	QUANTITY	UQP	CAT NO	ITEM NUMBER	UNIT PRICE	AMOUNT
ADDENDUM(S) AND HAVE MADE THE NECESSARY REVISIONS TO MY PROPOSAL, PLANS AND/OR SPECIFICATION, ETC. ADDENDUM NOS. : NO. 1 NO. 2 NO. 3 NO. 4 NO. 5						
I UNDERSTAND THAT FAILURE TO CONFIRM THE RECEIPT OF THE ADDENDUM(S) MAY BE CAUSE FOR REJECTION OF THE BIDS. VENDOR MUST CLEARLY UNDERSTAND THAT ANY VERBAL REPRESENTATION MADE OR ASSUMED TO BE MADE DURING ANY ORAL DISCUSSION HELD BETWEEN VENDOR'S REPRESENTATIVES AND ANY STATE PERSONNEL IS NOT BINDING. ONLY THE INFORMATION ISSUED IN WRITING AND ADDED TO THE SPECIFICATIONS BY AN OFFICIAL ADDENDUM IS BINDING.						
					SIGNATURE	
Pinnacle Electric, Inc.					COMPANY	
6/8/09					DATE	
REV. 11/96						
CONTRACTORS LICENSE <small>SEE REVERSE SIDE FOR TERMS AND CONDITIONS</small>						

SIGNATURE	TELEPHONE	DATE
TITLE	FEIN	ADDRESS CHANGES TO BE NOTED ABOVE

WHEN RESPONDING TO RFQ, INSERT NAME AND ADDRESS IN SPACE ABOVE LABELED 'VENDOR'



State of West Virginia
 Department of Administration
 Purchasing Division
 2019 Washington Street East
 Post Office Box 50130
 Charleston, WV 25305-0130

**Request for
 Quotation**

RFQ NUMBER
PSH90126

PAGE
8

ADDRESS CORRESPONDENCE TO ATTENTION OF
**ROBERTA WAGNER
 304-558-0067**

VENDOR

RFQ COPY
 TYPE NAME/ADDRESS HERE

SHIP TO

**HEALTH AND HUMAN RESOURCES
 PINECREST HOSPITAL
 105 SOUTH EISENHOWER DRIVE
 BECKLEY, WV
 25801
 304-256-6614**

DATE PRINTED	TERMS OF SALE	SHIP VIA	FOB	FREIGHT TERMS
--------------	---------------	----------	-----	---------------

BID OPENING DATE: **04/16/2009** **05/26/2009** BID OPENING TIME: **01:30PM**

LINE	QUANTITY	UOP	CAT. NO.	ITEM NUMBER	UNIT PRICE	AMOUNT
<p>WEST VIRGINIA STATE CODE 21-11-2 REQUIRES THAT ALL PERSONS DESIRING TO PERFORM CONTRACTING WORK IN THIS STATE MUST BE LICENSED. THE WEST VIRGINIA CONTRACTORS LICENSING BOARD IS EMPOWERED TO ISSUE THE CONTRACTORS LICENSE. APPLICATIONS FOR A CONTRACTORS LICENSE MAY B MADE BY CONTACTING THE WEST VIRGINIA DIVISION OF LABOR CAPITOL COMPLEX, BUILDING 3, ROOM 319, CHARLESTON, WV 25305. TELEPHONE: (304) 558-7890.</p> <p>WEST VIRGINIA STATE CODE 21-11-11 REQUIRES ANY PROSPECTIVE BIDDER TO INCLUDE THE CONTRACTORS LICENSE NUMBER ON THEIR BID.</p> <p>BIDDER TO COMPLETE:</p> <p>CONTRACTORS NAME: <i>Pinnacle Electric, Inc.</i></p> <p>CONTRACTORS LICENSE NO.: <i>WV044485</i></p> <p>THE SUCCESSFUL BIDDER WILL BE REQUIRED TO FURNISH A COPY OF THEIR CONTRACTORS LICENSE PRIOR TO ISSUANCE OF A PURCHASE ORDER/CONTRACT</p> <p style="text-align: center;">APPLICABLE LAW</p> <p>THE WEST VIRGINIA STATE CODE, PURCHASING DIVISION RULES AND REGULATIONS, AND THE INFORMATION PROVIDED IN THE "REQUEST FOR QUOTATION" ISSUED BY THE PURCHASING DIVISION IS THE SOLE AUTHORITY GOVERNING THIS PROCUREMENT.</p> <p>ANY INFORMATION PROVIDED IN SPECIFICATION MANUALS, OR ANY OTHER SOURCE, VERBAL OR WRITTEN, WHICH CONTRADICTS OR ALTERS THE INFORMATION PROVIDED FROM THE SOURCES AS DESCRIBED IN THE ABOVE PARAGRAPH IS VOID AND OF NO</p>						

SEE REVERSE SIDE FOR TERMS AND CONDITIONS

SIGNATURE	TELEPHONE	DATE
TITLE	FEIN	ADDRESS CHANGES TO BE NOTED ABOVE

WHEN RESPONDING TO RFQ, INSERT NAME AND ADDRESS IN SPACE ABOVE LABELED 'VENDOR'



State of West Virginia
 Department of Administration
 Purchasing Division
 2019 Washington Street East
 Post Office Box 50130
 Charleston, WV 25305-0130

**Request for
 Quotation**

RFQ NUMBER
PSH90126

PAGE
9

ADDRESS CORRESPONDENCE TO ATTENTION OF
**ROBERTA WAGNER
 304-558-0067**

VENDOR

RFQ COPY
 TYPE NAME/ADDRESS HERE

SHIP TO

**HEALTH AND HUMAN RESOURCES
 PINECREST HOSPITAL
 105 SOUTH EISENHOWER DRIVE
 BECKLEY, WV
 25801
 304-256-6614**

DATE PRINTED	TERMS OF SALE	SHIP VIA	FOB	FREIGHT TERMS
04/16/2009				

BID OPENING DATE: **05/26/2009** BID OPENING TIME: **01:30PM**

LINE	QUANTITY	UOP	CAT. NO.	ITEM NUMBER	UNIT PRICE	AMOUNT
<p>EFFECT.</p> <p>BANKRUPTCY: IN THE EVENT THE VENDOR/CONTRACTOR FILES FOR BANKRUPTCY PROTECTION, THIS CONTRACT IS AUTOMATICALLY NULL AND VOID, AND IS TERMINATED WITHOUT FURTHER ORDER.</p> <p>REV. 1/2005</p> <p style="text-align: center;">NOTICE</p> <p>A SIGNED BID MUST BE SUBMITTED TO:</p> <p style="text-align: center;">DEPARTMENT OF ADMINISTRATION PURCHASING DIVISION BUILDING 15 2019 WASHINGTON STREET, EAST CHARLESTON, WV 25305-0130</p> <p>PLEASE NOTE: A CONVENIENCE COPY WOULD BE APPRECIATED. THE BID SHOULD CONTAIN THIS INFORMATION ON THE FACE OF THE ENVELOPE OR THE BID MAY NOT BE CONSIDERED:</p> <p>SEALED BID</p> <p>BUYER: -----RW/FILE 22-----</p> <p>REQ. NO.: -----PSH90126-----</p> <p>BID OPENING DATE: -----05/26/2009-----</p> <p>BID OPENING TIME: -----1:30 PM-----</p> <p>PLEASE PROVIDE A FAX NUMBER IN CASE IT IS NECESSARY TO CONTACT YOU REGARDING YOUR BID:</p>						

SEE REVERSE SIDE FOR TERMS AND CONDITIONS

SIGNATURE	TELEPHONE	DATE
TITLE	FEIN	ADDRESS CHANGES TO BE NOTED ABOVE

WHEN RESPONDING TO RFQ, INSERT NAME AND ADDRESS IN SPACE ABOVE LABELED 'VENDOR'



State of West Virginia
 Department of Administration
 Purchasing Division
 2019 Washington Street East
 Post Office Box 50130
 Charleston, WV 25305-0130

Request for
 Quotation

RFQ NUMBER
 PSH90126

PAGE
 10

ADDRESS CORRESPONDENCE TO ATTENTION OF
 ROBERTA WAGNER
 304-558-0067

VENDOR

RFQ COPY
 TYPE NAME/ADDRESS HERE

SHIP TO

HEALTH AND HUMAN RESOURCES
 PINECREST HOSPITAL
 105 SOUTH EISENHOWER DRIVE
 BECKLEY, WV
 25801 304-256-6614

DATE PRINTED	TERMS OF SALE	SHIP VIA	FOB	FREIGHT TERMS
04/16/2009				

BID OPENING DATE: 05/26/2009 BID OPENING TIME 01:30PM

LINE	QUANTITY	UOP	CAT NO	ITEM NUMBER	UNIT PRICE	AMOUNT
----- PLEASE PRINT OR TYPE NAME OF PERSON TO CONTACT CONCERNING THIS QUOTE: KEVAN MEMEL 304-991-2286 -----						
0002	10	EA		936-73 UNINTERRUPTIBLE POWER SUPPLY	333.42	3,334.20
0003	5	EA		936-73 16 CHANNEL POWER SUPPLY	290.56	1,452.80
0004	53	EA		936-73 SONY SPE-110, OR EQUAL, VANDAL PROOF DOME CAMERA	249.24	13,209.54
0005	10	EA		936-73 OUTDOOR CAMERA WITH 5-50 MM VARIFOCAL LENS	401.64	4,016.40

SEE REVERSE SIDE FOR TERMS AND CONDITIONS

SIGNATURE	TELEPHONE	DATE
TITLE	FEIN	ADDRESS CHANGES TO BE NOTED ABOVE

WHEN RESPONDING TO RFQ, INSERT NAME AND ADDRESS IN SPACE ABOVE LABELED 'VENDOR'



State of West Virginia
 Department of Administration
 Purchasing Division
 2019 Washington Street East
 Post Office Box 50130
 Charleston, WV 25305-0130

Request for
 Quotation

RFQ NUMBER
 PSH90126

PAGE
 11

ADDRESS CORRESPONDENCE TO ATTENTION OF
 ROBERTA WAGNER
 304-558-0067

POSTER

RFQ COPY
 TYPE NAME/ADDRESS HERE

SHIP TO

HEALTH AND HUMAN RESOURCES
 PINECREST HOSPITAL
 105 SOUTH EISENHOWER DRIVE
 BECKLEY, WV
 25801 304-256-6614

DATE PRINTED	TERMS OF SALE	SHIP VIA	F.O.B.	FREIGHT TERMS
04/16/2009				

LINE	QUANTITY	UOP	CAT NO	ITEMNUMBER	UNIT PRICE	AMOUNT
0006	10	EA		936-73	274.74	2,747.30
				WEATHER PROOF HOUSING FOR OUTDOOR CAMERAS		
0007	1	JB		936-73	0	3,575.35
				MOUNTING BRACKETS, CABLE AND CABLE TERMINATIONS		
0008	1	JB		936-73	0	0
				REQUIRED SOFTWARE FOR SECURITY SYSTEM		
0009	1	JB		936-73	817.21	51,484.43
				LABOR COSTS		
0010	1	LS		936-73	0	0
				ALL OTHER COSTS (PLEASE SPECIFY)		

SEE REVERSE SIDE FOR TERMS AND CONDITIONS		
SIGNATURE	TELEPHONE	DATE
TITLE	FEIN	ADDRESS CHANGES TO BE NOTED ABOVE

WHEN RESPONDING TO RFQ, INSERT NAME AND ADDRESS IN SPACE ABOVE LABELED 'VENDOR'



State of West Virginia
 Department of Administration
 Purchasing Division
 2019 Washington Street East
 Post Office Box 50130
 Charleston, WV 25305-0130

Request for
 Quotation

RFQ NUMBER
 PSH90126

PAGE
 12

ADDRESS CORRESPONDENCE TO ATTENTION OF
 ROBERTA WAGNER
 304-558-0067

TO ORDER

RFO COPY
 TYPE NAME/ADDRESS HERE

SHIP TO

HEALTH AND HUMAN RESOURCES
 PINECREST HOSPITAL
 105 SOUTH EISENHOWER DRIVE
 BECKLEY, WV
 25801 304-256-6614

DATE PRINTED	TERMS OF SALE	SHIP VIA	F.O.B.	FREIGHT TERMS
04/16/2009				

BID OPENING DATE: 05/26/2009 BID OPENING TIME 01:30PM

LINE	QUANTITY	UOP	GAT. NO.	ITEM NUMBER	UNIT PRICE	AMOUNT
***** THIS IS THE END OF RFO PSH90126 ***** TOTAL:						\$ 87,989.63

SEE REVERSE SIDE FOR TERMS AND CONDITIONS

SIGNATURE	TELEPHONE	DATE
TITLE	FEIN	ADDRESS CHANGES TO BE NOTED ABOVE

WHEN RESPONDING TO RFQ, INSERT NAME AND ADDRESS IN SPACE ABOVE LABELED 'VENDOR'

REQUEST FOR QUOTATION
PSH90126

1. GENERAL INFORMATION:

- 1.1. Request for Quotation to provide all labor, materials, equipment and anything incidental to the removal, legal disposal of specific security equipment, installation of new security equipment and components, security system startup, testing, and adjustments listed herein at Pinecrest Hospital 105 South Eisenhower Drive, Beckley, WV 25801.
- 1.2. All work will be in compliance with the Fire Marshal regulations and all other building codes and industry standards. Final payment will be withheld if installed components are not in compliance, or any portion of this overall project is not 100% complete. The award will be made to the overall low bid that complies with the specifications.
- 1.3. "Will", "must", and "shall" listed herein this document is a mandatory requirement.
- 1.4. The cameras, all mounting hardware, cabling, DVRs, networking equipment and miscellaneous hardware or software, as well as the connections, communications, and/or other interactions between the components, will be referred to as the security system throughout this document.

2. BIDDER REQUIREMENTS:

- 2.1. All qualified bidders, being familiar with and understanding the bidding documents and also having examined the site and being familiar with all local conditions affecting the project hereby propose to furnish all labor, material, equipment, supplies and to perform all work in accordance with the bidding documents within the time set forth below.
- 2.2. It is the bidder's responsibility to verify all field conditions and limitations prior to bidding. It is also the bidder's responsibility to notify the West Virginia Department of Health & Human Resources in writing, of conditions detrimental to proper and timely completion of the repair/upgrade. Do not proceed until nonconforming conditions have been corrected.
- 2.3. Mandatory Prebid Conference: (Agency Option)
A mandatory prebid conference shall be conducted on the date specified 5/5/9 at 11:00 a.m. Said conference will be held at Pinecrest Hospital, 105 S. Eisenhower Dr., Beckley, WV 25801, Room #B-109. All interested bidders are required to be present at this meeting. Failure to attend the mandatory prebid conference shall automatically result in disqualification. No one person can represent more than one vendor.

3. SCOPE OF WORK:

3.1. Pinecrest Hospital has a need to install surveillance cameras at various locations in the Hospital and outside the hospital. The locations are identified in the attached building diagrams. The security system cameras shall record at all times, this includes during backup times and when other cameras are being viewed. The system needs to provide the capability to view any camera or multiple cameras from any network attached PC. The system shall provide a means to backup the data obtained from the cameras from a central location.

3.2. Digital Video Recorders

- 3.2.1. A total of five (5) digital video recorders (DVR) will be required.**
- 3.2.2. All storage for the camera system shall be digital.**
- 3.2.3. All DVRs shall have a minimum of 1.0 TB of storage space. The hard drive shall have incident back up.**
- 3.2.4. All DVRs shall provide the capability to backup data locally as well as the ability to backup to a central location. DVR storage space will be provided by the facility over the Pinecrest Hospital network and will be in the computer room located on Unit 1A.**
- 3.2.5. All DVRs shall provide the capability to record from all channels simultaneously.**
- 3.2.6. All DVRs shall be accessible from any PC connected to the DHHR network at Pinecrest Hospital.**
- 3.2.7. All DVRs shall provide logon security in the form of user IDs and passwords.**
- 3.2.8. Each DVR shall be connected to an Uninterruptible Power Supply (UPS). Each UPS shall be capable of supporting 1200VA, at minimum.**
- 3.2.9. Five (5) DVRs shall operate with a Windows based system. Vendor must advise facility if additional computers for every DVR will be necessary.**
- 3.2.10. The bidder must provide mounting equipment for the DVRs.**

3.3. Data Backup

- 3.3.1. The camera system shall provide the capability to backup the data from each DVR to a central location – the Information System area which is located in room A-136.**
- 3.3.2. The centralized backup shall be completed on DVD media. Pinecrest Hospital personnel will perform the backups on a facility determined backup schedule.**

3.4. Cabling

- 3.4.1. All cables installed for the camera system shall be located in drop ceilings where available or in metal conduit.**
- 3.4.2. All cables installed shall meet or exceed all pertinent building codes and regulations.**

3.5. Indoor Cameras

- 3.5.1. Cameras installed inside Pinecrest Hospital shall be a Sony SPE-110 or a camera that is equal. The camera shall have a vandal proof dome. The camera shall be a color camera with an auto focusing lens. The camera lens shall have a minimum of 2.8 to 4.0 mm and a maximum 10 – 15 mm view.**
- 3.5.2. Contractor shall furnish and install fifty-three (53) indoor cameras identified in**

3.5.1.

- 3.5.3. Minimum camera resolution shall be 640 x 480.
- 3.5.4. Camera frame rate shall be 6 fps at a minimum; frame rate per second above this will be acceptable.

3.6. Outdoor Cameras

- 3.6.1. Cameras installed on the exterior of Pinecrest Hospital shall provide a view of the parking lots and facility grounds. The cameras shall also have a 5- 50 mm varifocal lenses.
- 3.6.2. All outdoor cameras shall be installed in a weather proof housing that has a heater and blower. The heater shall activate when the temperature reaches 0 degrees Fahrenheit and the blower shall activate when the temperature reaches 130 degrees Fahrenheit.
- 3.6.3. Contractor shall furnish and install ten (10) outdoor cameras as identified in 3.6.1 and ten (10) weather proof housing as identified in 3.6.2.

3.7. Power Supplies

- 3.7.1. All cameras shall be connected to multi-channel power supplies.
- 3.7.2. Five (5) 16 channel power supplies will be required.
- 3.7.3. All power supplies shall be connected to an uninterruptible Power Supply (UPS) Each UPS shall be capable of supporting 1200VA, at minimum.

3.8. Miscellaneous Hardware

- 3.8.1. Mounting brackets for all cameras shall be provided by the contractor.
- 3.8.2. Cable and cable terminations shall be provided by the contractor with a minimum of a 3' terminal length.
- 3.8.3. Current wall and floor penetrations for cabling can be used, but the vendor shall replace any fire block that is removed. In addition, all new penetrations must be sleeved and fire blocked.
- 3.8.4. Conduit and junction boxes shall be provided by the contractor.
- 3.8.5. Any other miscellaneous hardware that is required to install a high quality functioning camera system at Pinecrest Hospital shall be provided by the contractor.

3.9. Computers and software

- 3.9.1. The contractor shall install and configure computer hardware required for the security system.
- 3.9.2. The contractor shall provide required software for the security system. If the software must be installed on computers connected to the DHHR network the software will meet all Office of Technology compatibility requirements which shall be Windows XP or Windows Vista.
- 3.9.3. The contractor shall train personnel identified by the owner on the use and administration of the security system.

- 3.10. Minor deviations from the stated specification not listed as mandatory (must, shall, or will) are acceptable to facilitate a competitive bidding atmosphere, provided the intent of the Request for Quotation or the effectiveness of the system is not compromised.

4. INSPECTION:

- 4.1. Contractor shall inspect existing conditions governing this work during pre-bid site inspection to determine conditions and extent of work required. No allowance will be made subsequently on behalf of the contractor for any error or negligence on his part in connection with this requirement.
- 4.2. The Contractor shall inspect all elements subject to movement or damage prior to commencing work.

5. Installation Plan (Shop Drawings):

Contractor shall provide an installation plan to owner for approval. The Installation Plan shall include a summary of work to be performed and normal configuration of devices and accessories that will be installed. The Installation Plan will include any deviations from the normal configuration of devices and accessories as explained in the summary. The Installation Plan shall include building drawings specifying products, product location, all identifying numbers of product (i.e. serial number, IP address, etc.), accessories and installation methods for the scope of work as defined in Section 3. The Installation Plan shall include a project schematic that will include the data flow from the end devices to the storage devices as well as the interconnection between all devices. The Installation Plan shall include a bill of materials (BOM) that contains, but not limited to, quantity, vendor number, serial number, manufacture part number, description and list price of each item. The Installation Plan shall include an initial schedule for the project. Any deviations in the initial schedule shall be communicated to the owner and approved before changes take place. A notice to proceed will be issued indicating approval of the shop drawings.

6. TEMPORARY FACILITIES:

- 6.1. The Owner will provide normal electrical supply from the currently installed electrical system in the building for the use of the contractor. However, the Owner provides no guarantee or warranty as to the systems condition or capabilities. The Contractor shall assure himself that the electrical system is adequate for his requirements or supply additional temporary electrical power at his own expense.
- 6.2. Any damage to the electrical system resulting from misuse or abuse to the existing electrical system shall be repaired or replaced by the contractor at no expense to the owner.

7. COORDINATION OF WORK:

- 7.1. The Contractor shall coordinate with Information Systems personnel and the maintenance supervisor for the proper relation of the work to the building structure and to the employees therein. In the event of conflict the building employees shall prevail.

7.2. The Contractor shall take all necessary precautions to protect the interior of the building from debris, dust or any residue occurring from the scope of work.

8. WARRANTY: (GUARANTEE)

8.1. The Contractor shall warrant to the Owner all materials and equipment will be new, and that all work will be of good quality, free from faults and defects in conformance with the contract documents. All work not conforming to these requirements may be considered defective.

8.2. All materials and equipment shall be of current year production of manufacturer and manufactured for commercial usage. Used, reconditioned or remanufactured equipment is not acceptable.

8.3. Successful bidder shall submit full commercial warranty information. The warranty information shall minimally contain the product warranty.

9. PERMITS:

The Contractor shall secure and pay for the building permit and for all other permits, governmental fees and licenses which are necessary for the proper execution and completion of the work as specified.

10. CLEAN UP:

The Contractor shall keep the work area as clean as possible during the entire progress of work, and shall be responsible to remove from the site, the packaging materials from his products and other debris as it accumulates. All items of equipment that are removed to allow the installation of new items will become the property of the contractor to dispose of at a landfill or location authorized to accept the items as waste or recycled parts.

11. WAGE RATES:

The Contractor and any sub-contractors shall pay the higher of the U.S. Department of Labor Minimum wage rates or of the West Virginia Department of Labor wage rates as established for Raleigh county pursuant to West Virginia Code 21-5-1, et seq. West Virginia Department of Labor Wage Rates are available at website: <http://www.wvsos.com/adlaw/wagerates/building06.htm>

12. PAYMENT SCHEDULE:

12.1. The Contractor shall submit to the Owner one original invoice when the contracted work is completed in its entirety upon inspection and approval by the owner.

12.2. The Owner reserves the right to refuse payment in the event the completed

work is not in accordance with industry standards or sub-standard in any way, or, if the amount requested is not within the agreed upon terms of the contract.

13. TERM OF WORK:

All work shall be complete within 120 calendar days from the approval of the installation plan/notice to proceed letter.

14. DELAYS AND EXTENSION OF TIME:

If the Contractor is delayed at any time in the progress of the work by any act or neglect of the Owner or by any employee of the Owner, or by any separate contractor employed by the Owner, or by changes in the work, or by labor disputes, fire, unusual delay in transportation, adverse weather conditions not reasonably anticipated, unavoidable casualties, or any other cause which the Owner determines may justify the delay, then the contract time may be extended by written approval of the Owner.

15. TOOLS AND EQUIPMENT STORAGE:

Contractor may set a trailer or temporary storage building on the site for all equipment and tools. The Contractor is responsible for his tools, equipment and materials.

16. SAFETY EQUIPMENT:

The Contractor shall provide safety barriers around work areas where heavy equipment may be in operation when placing materials in the building or as required by OSHA.

17. DAMAGES:

Any damages occurring to the building or property resulting from the contractor's performance of this work shall be the responsibility of the contractor to repair at his expense, either by using his own forces or that of an approved sub-contractor. The repair method and finished product will be subject to the approval of the owner.

18. SCHEDULE OF BID RESPONSES:

- 18.1. Bidders shall submit one lump-sum bid for all the work under all the terms and conditions as described herein. In addition, please note that this project will be awarded to the vendor with the lowest total bid that meets all of the specifications.

Bid Schedule / Cost Proposal

Quantity	Description	Price for Each	Extended Amount
5 each	Digital Video Recorders per specifications	\$ <u>1,633.91</u>	\$ <u>8,169.55</u>
10 each	Uninterruptible Power Supply	\$ <u>333.42</u>	\$ <u>3,334.20</u>
5 each	16 channel Power Supply	\$ <u>290.56</u>	\$ <u>1,452.80</u>
53 each	Sony SPE-110 (or equal) vandal proof dome color camera with minimum 2.8-4mm to maximum 10-15mm auto focusing lens for indoor use	\$ <u>249.24</u>	\$ <u>13,209.54</u>
10 each	Outdoor camera with 5 - 50 mm varifocal lens	\$ <u>401.64</u>	\$ <u>4,016.40</u>
10 each	Weather proof housing for outdoor cameras	\$ <u>274.74</u>	\$ <u>2,747.36</u>
1 job	Mounting brackets, cable and cable terminations with a minimum of 3' length, conduit and junction boxes, other miscellaneous hardware and network equipment.	\$ <u>0</u>	\$ <u>3,575.35</u>
1 job	Required software for security system	\$ <u>0</u>	\$ <u>0</u>
1 job	Labor costs	\$ <u>817.21</u>	\$ <u>5,484.43</u>
	All other costs (please specify)	\$ <u>0</u>	\$ <u>0</u>
	Grand Total	\$ <u>4,000.72</u>	\$ <u>87,989.63</u>

SUMMARY OF DRAWING

			UPS	
Outside	1	Digital Video Recorders	1	1
Basement	1	16 channel		
1st Floor	2			
2nd Floor	2	Power Supply	1	1
3rd Floor	1	minimum 16 channel		
Total	7			

SUMMARY OF DRAWING

Outside	4	Digital Video Recorders	2	2
Basement	0	16 channel		
1st Floor	9			
2nd Floor	4			
3rd Floor	4	Power Supply	2	2
4th Floor	3	minimum 16 channel		
Total	24			

SUMMARY OF DRAWING

Outside	1	Digital Video Recorders	1	1
Basement	1	16 channel		
1st Floor	4			
2nd Floor	4			
3rd Floor	3	Power Supply	1	1
		minimum 16 channel		
Total	13			

SUMMARY OF DRAWING

Outside	3	Digital Video Recorders	1	1
Basement	1	16 channel		
1st Floor	3			
2nd Floor	1			
3rd Floor	2	Power Supply	1	1
4th Floor	2	minimum 16 channel		
5th Floor	2			
6th Floor	2			
Total	16			

Outside	1			
Basement	0			
1st Floor	1			
2nd Floor	1			
Total	3			
GRAND TOTAL	63			10

PINECREST HOSPITAL
ATTACHMENT A

NOTE: This map is not to scale.
The purpose of this map is to give
the vendors an idea of how all of
the units are connected. Please see
following detailed drawings for
precise maps.

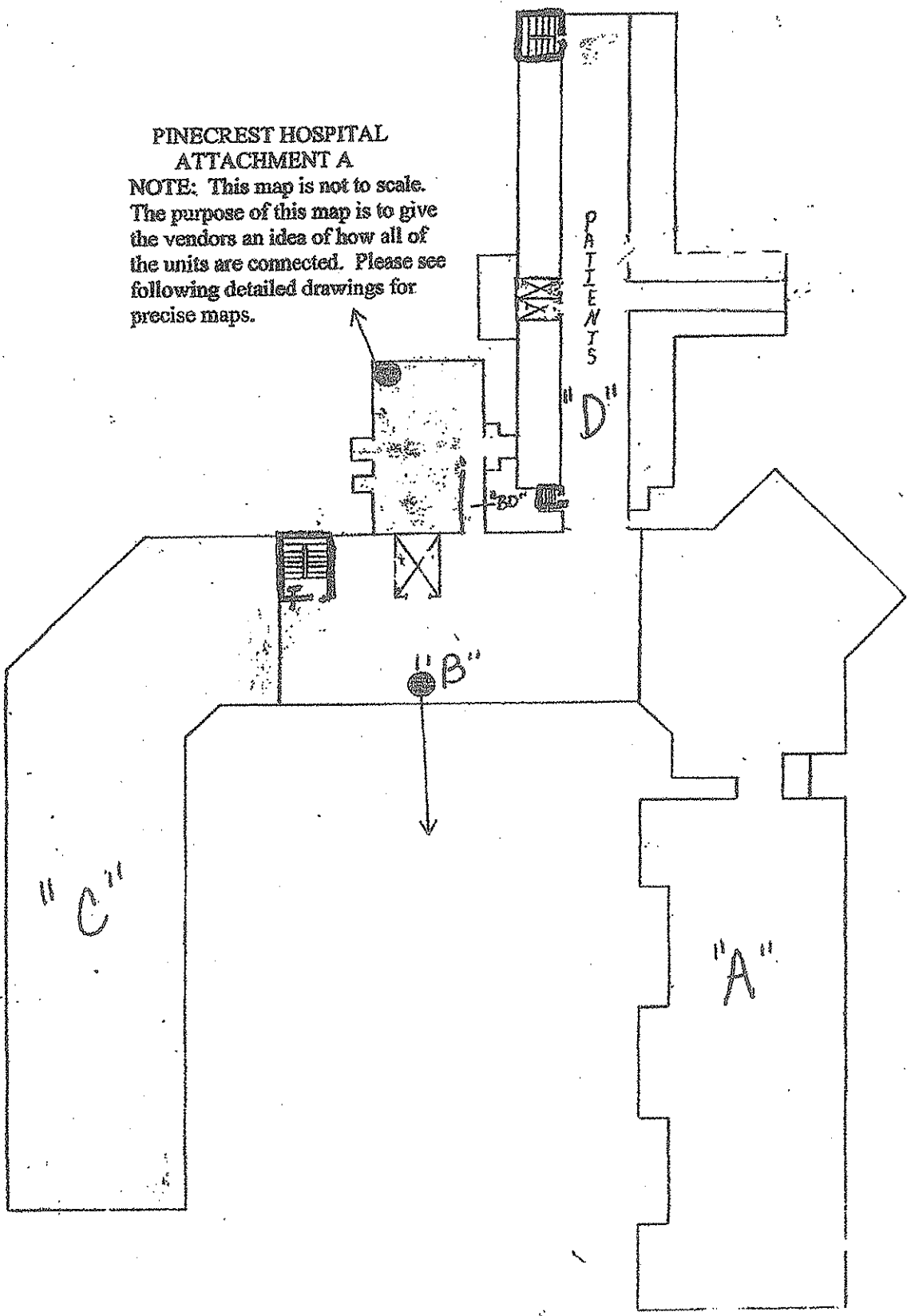

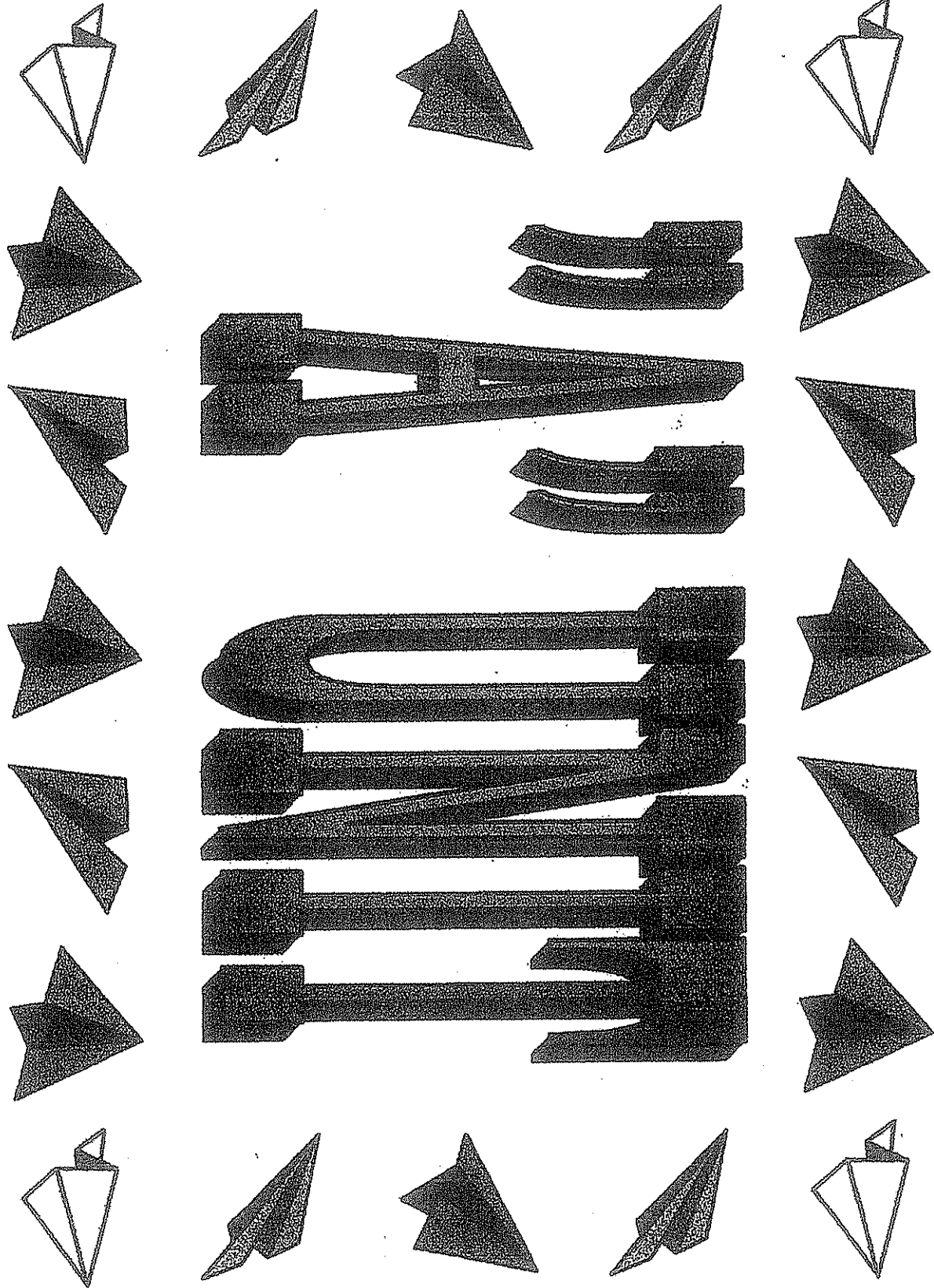

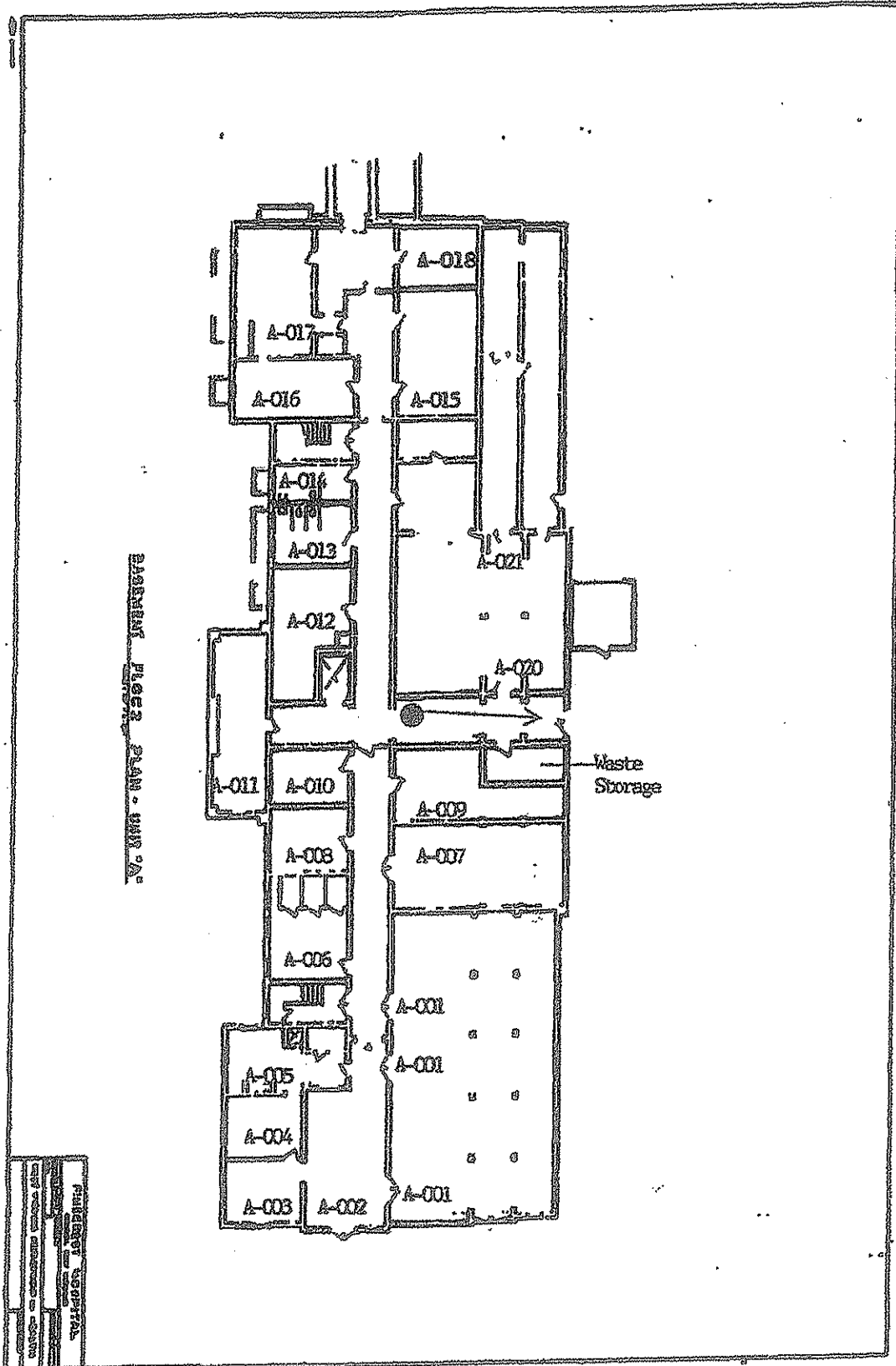

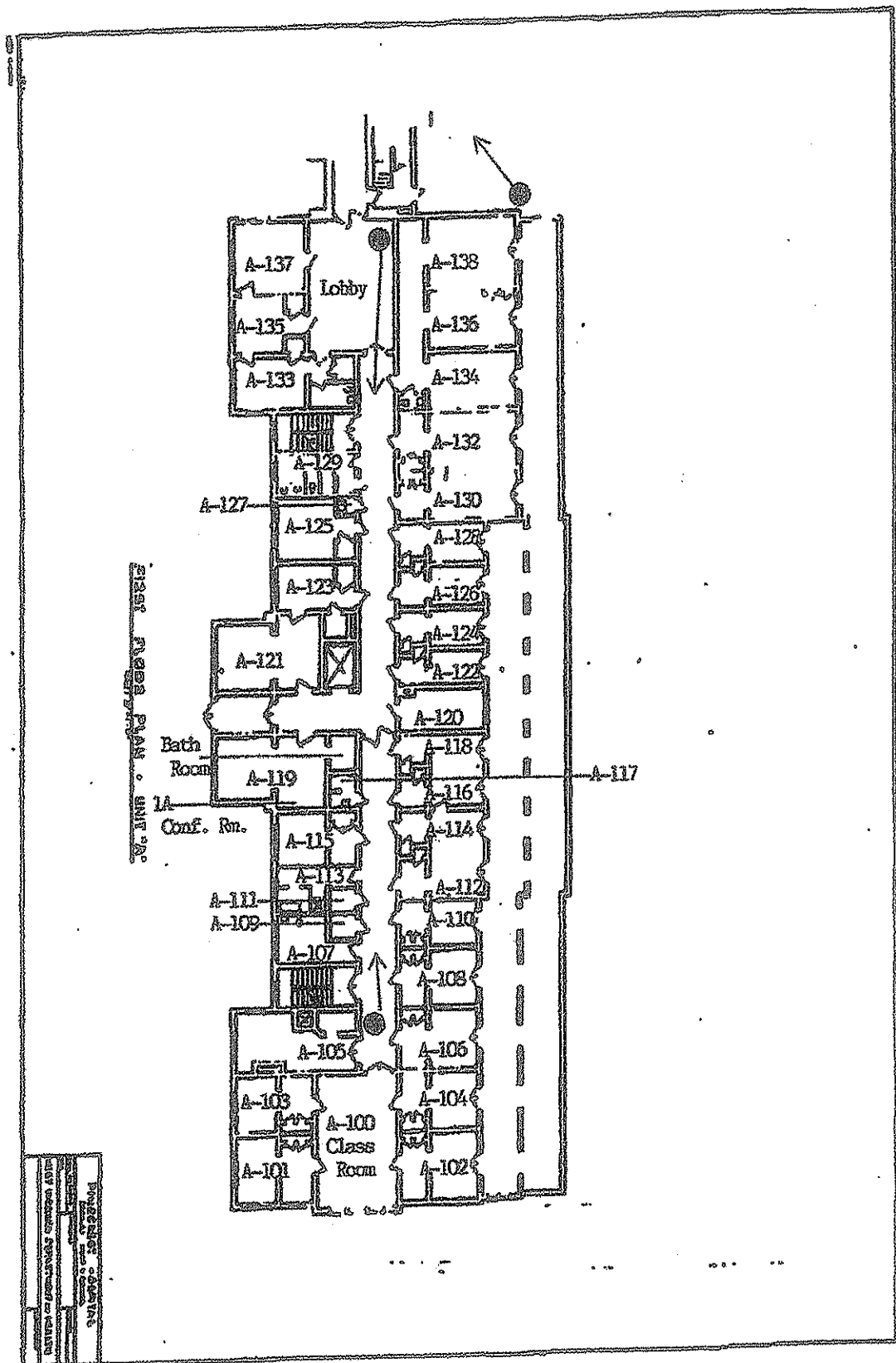

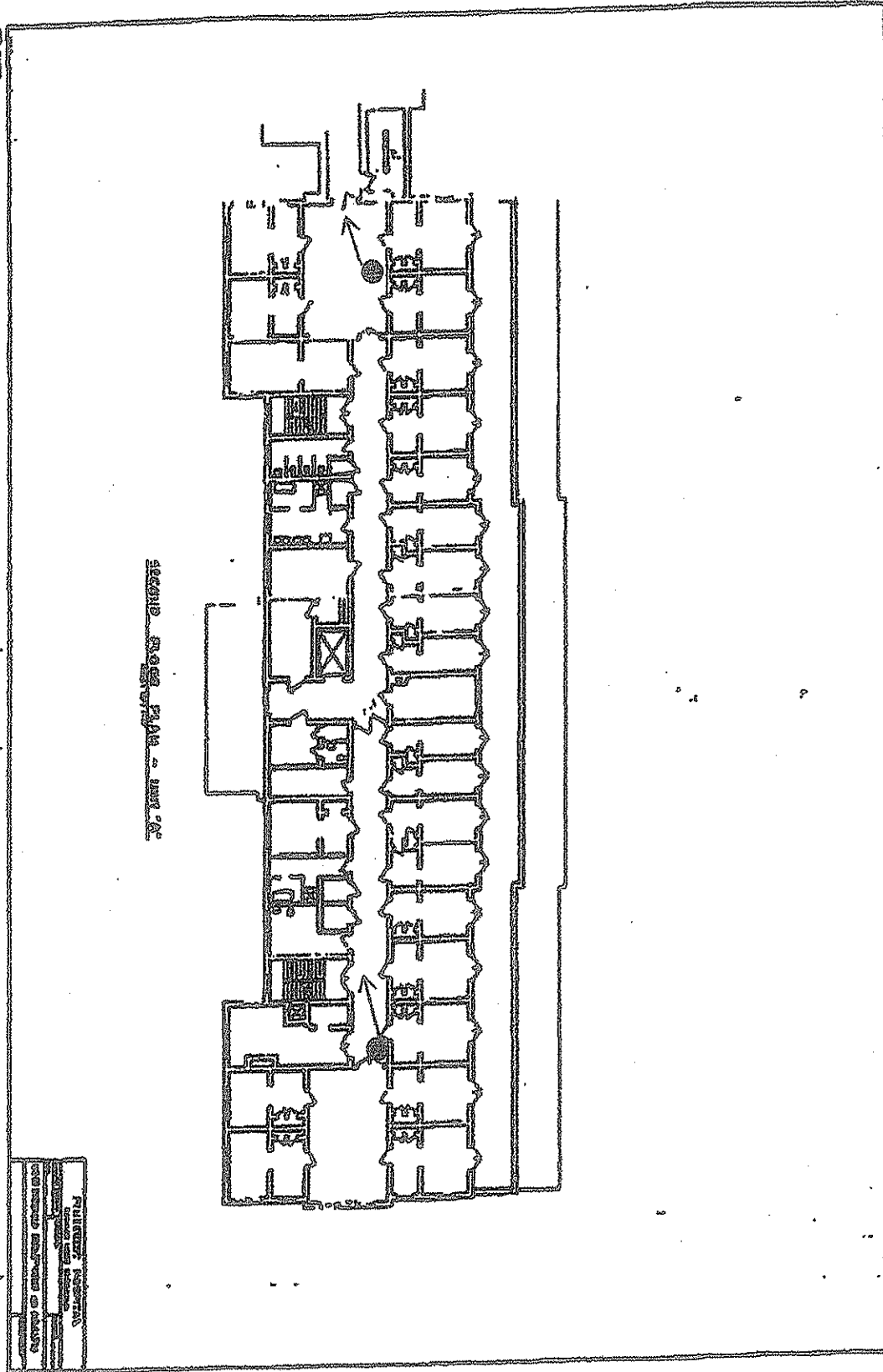

PROJECT: RECONSTRUCTION
 DRAWING NO.: 256-6616-025
 DATE: 07/18/95
 SCALE: AS SHOWN
 SHEET NO.: 25 OF 25

SECOND FLOOR

THIRD FLOOR PLAN - 1995

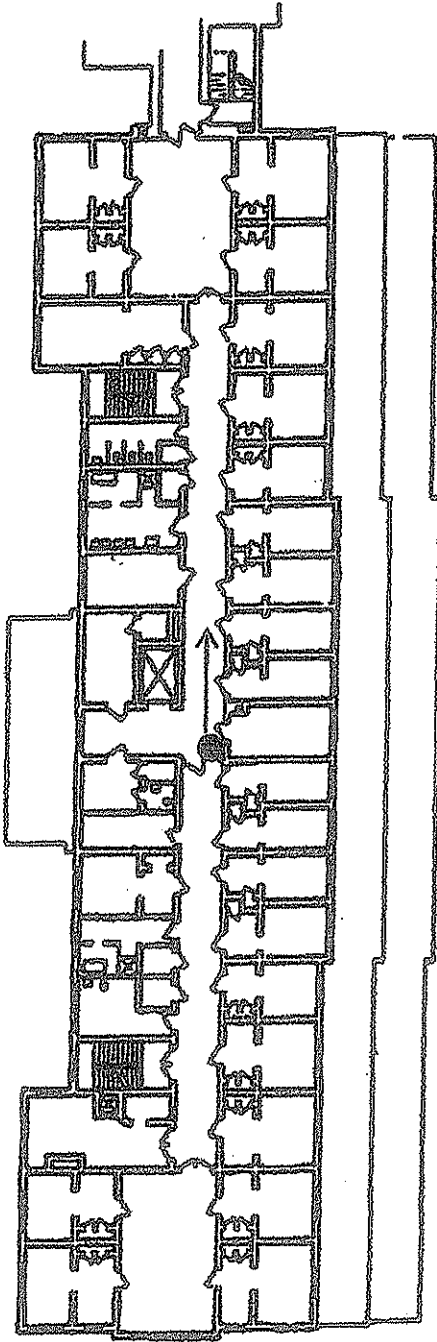

1	STAIRWELL
2	ELEVATOR
3	OFFICE
4	STORAGE
5	UTILITY
6	RESTROOM
7	CONFERENCE
8	RECEPTION
9	LABORATORY
10	MEETING
11	TRAINING
12	WORKSHOP
13	RECEPTION
14	STAIRWELL
15	ELEVATOR
16	OFFICE
17	STORAGE
18	UTILITY
19	RESTROOM
20	CONFERENCE
21	RECEPTION
22	LABORATORY
23	MEETING
24	TRAINING
25	WORKSHOP

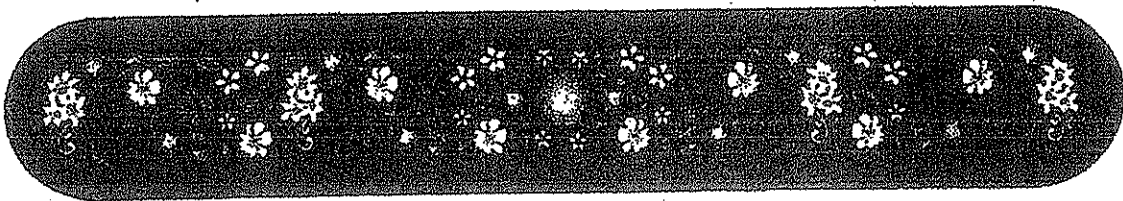
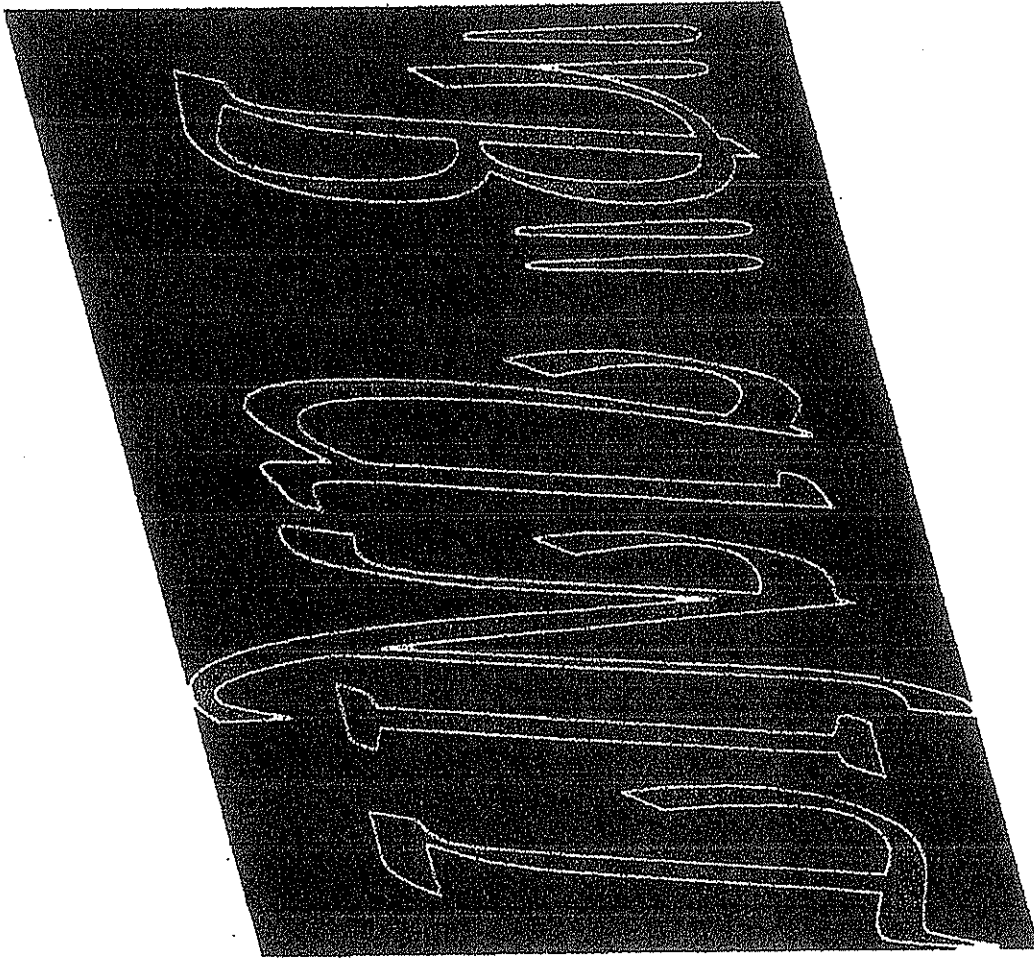
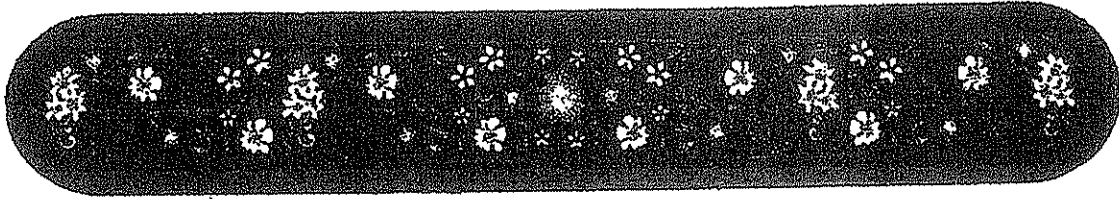

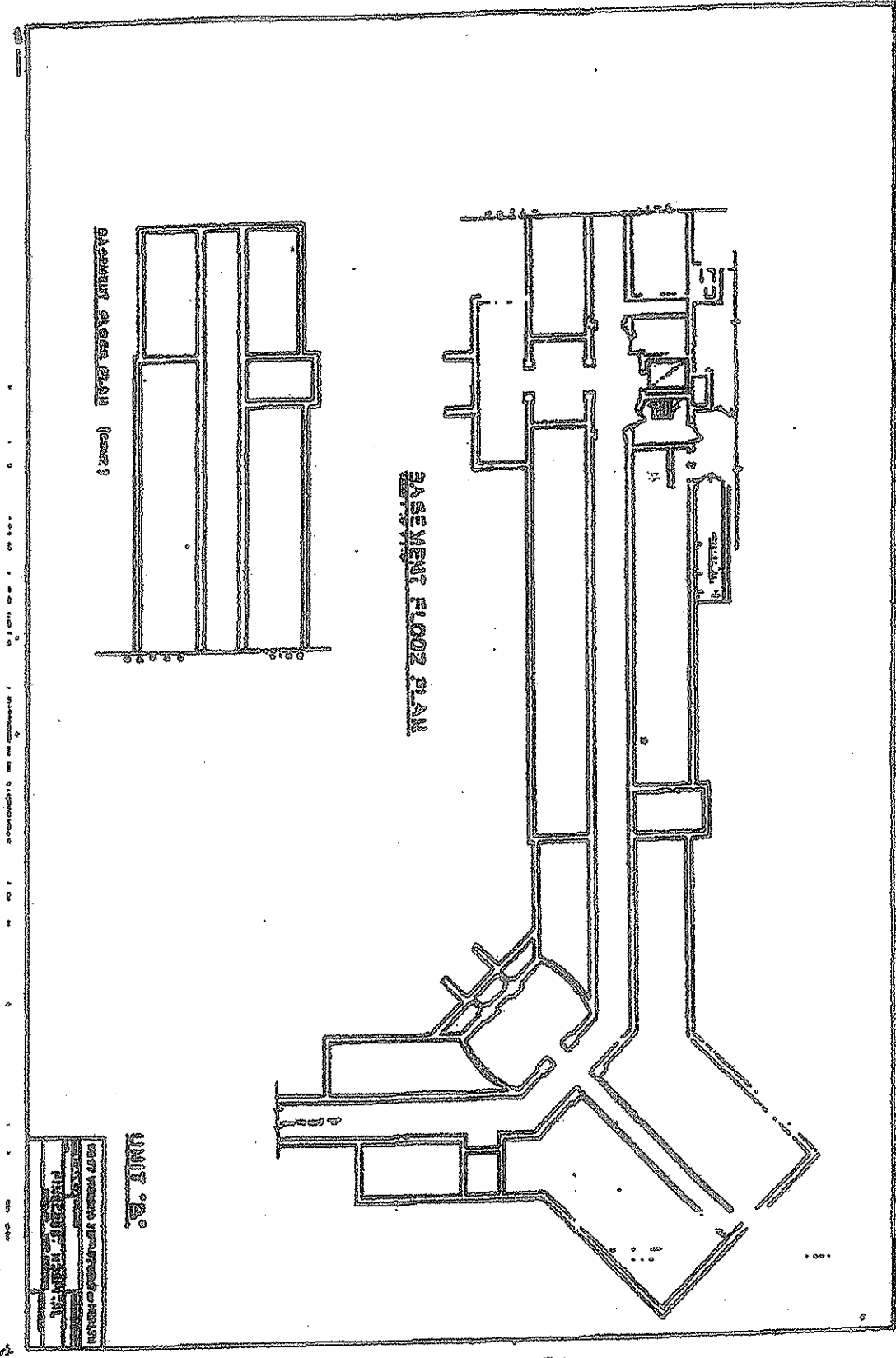

BASMENT FLOOR PLAN

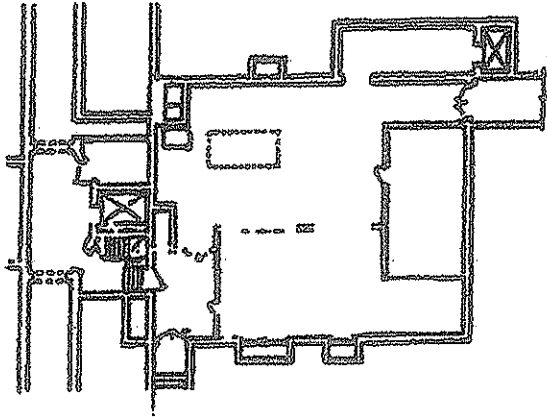

FIRST FLOOR PLAN - KITCHEN & DINING

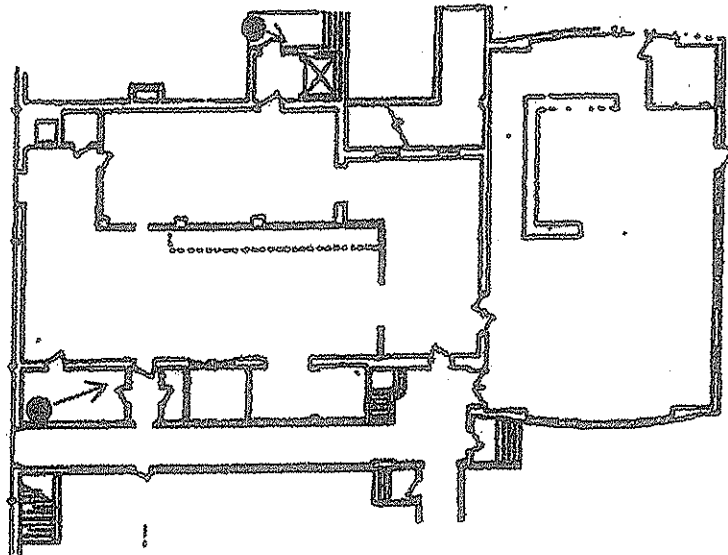

SECOND FLOOR - AUDITORIUM

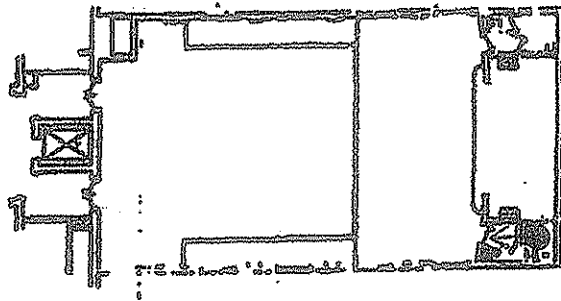

JUN 28 - BREAKFAST WING

NO. 916	NO. 916	NO. 916
NO. 916	NO. 916	NO. 916
NO. 916	NO. 916	NO. 916

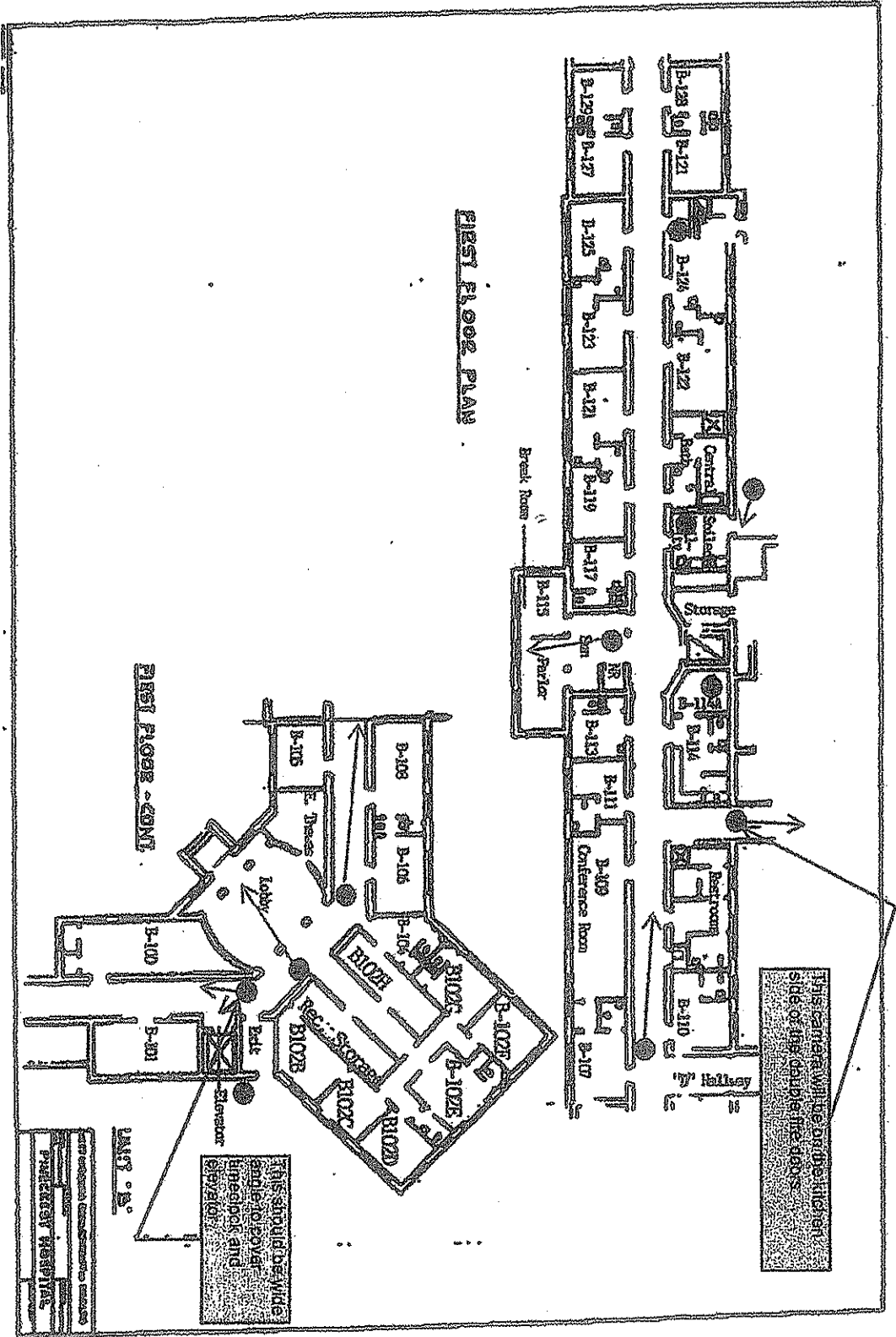

FIRST FLOOR PLAN

FIRST FLOOR - CONT.

This should be wide enough to cover fireplace and chimney.

This should be wide enough to cover fireplace and chimney.

PART 'A'
PULPERY RECEPTION

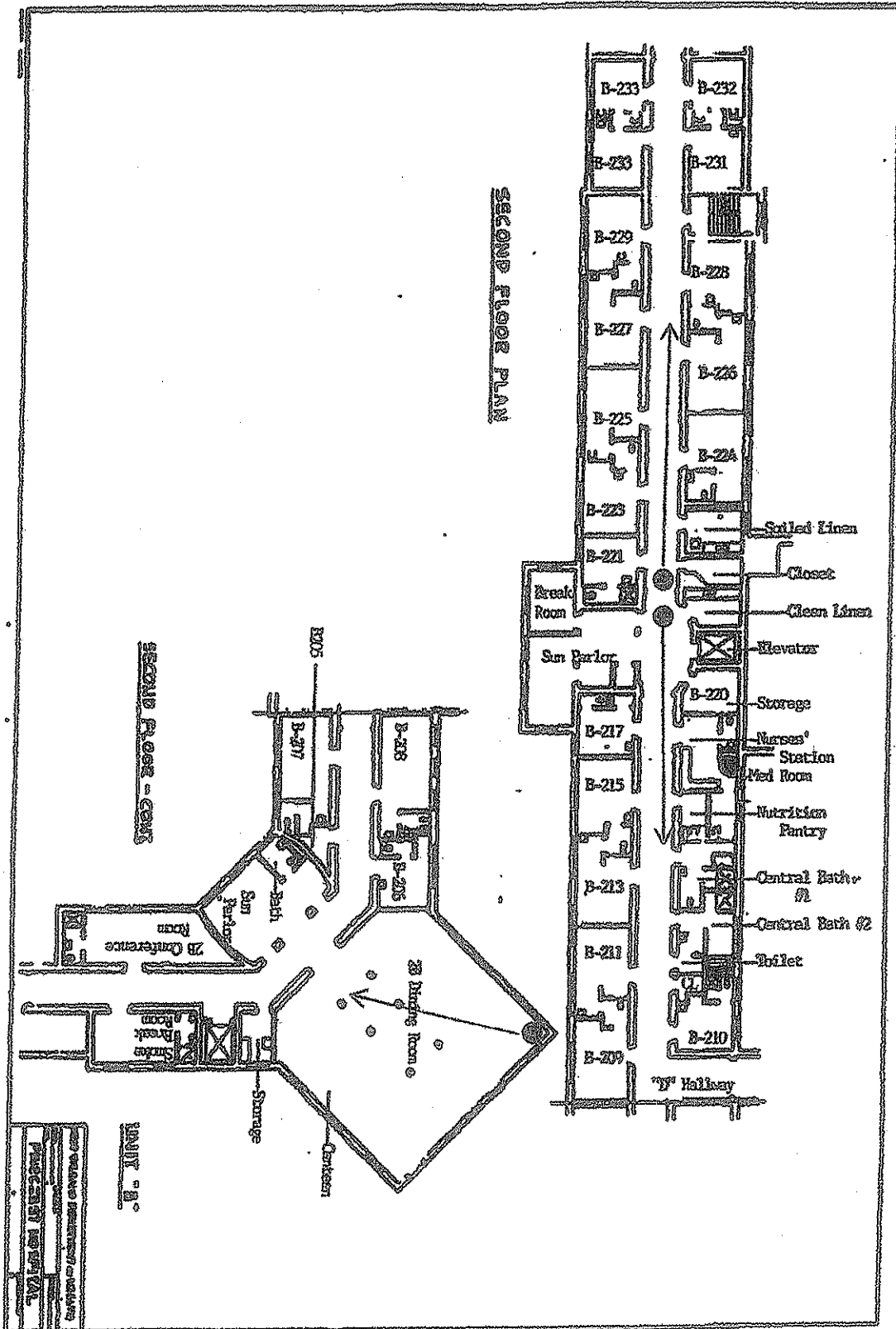

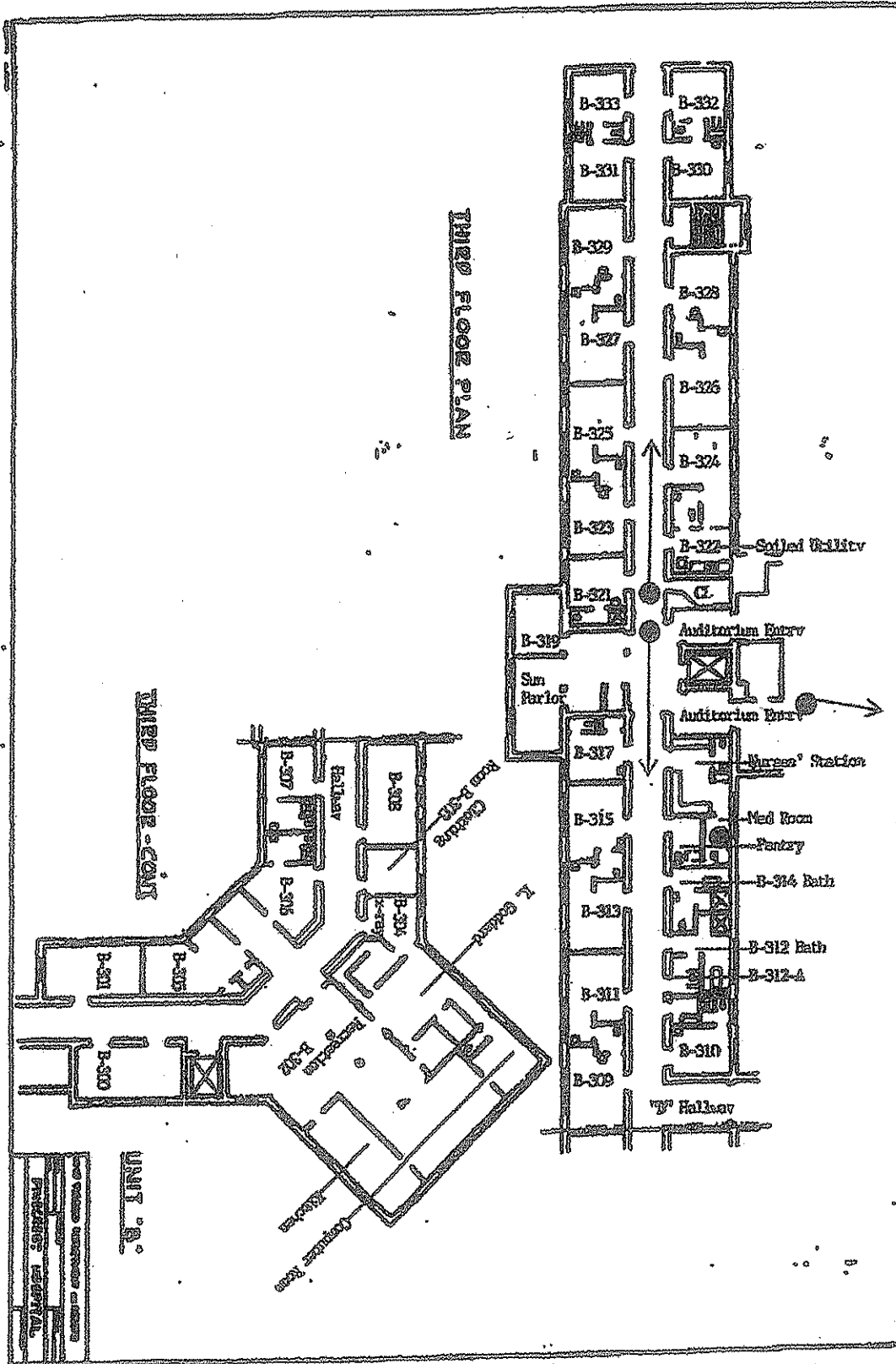

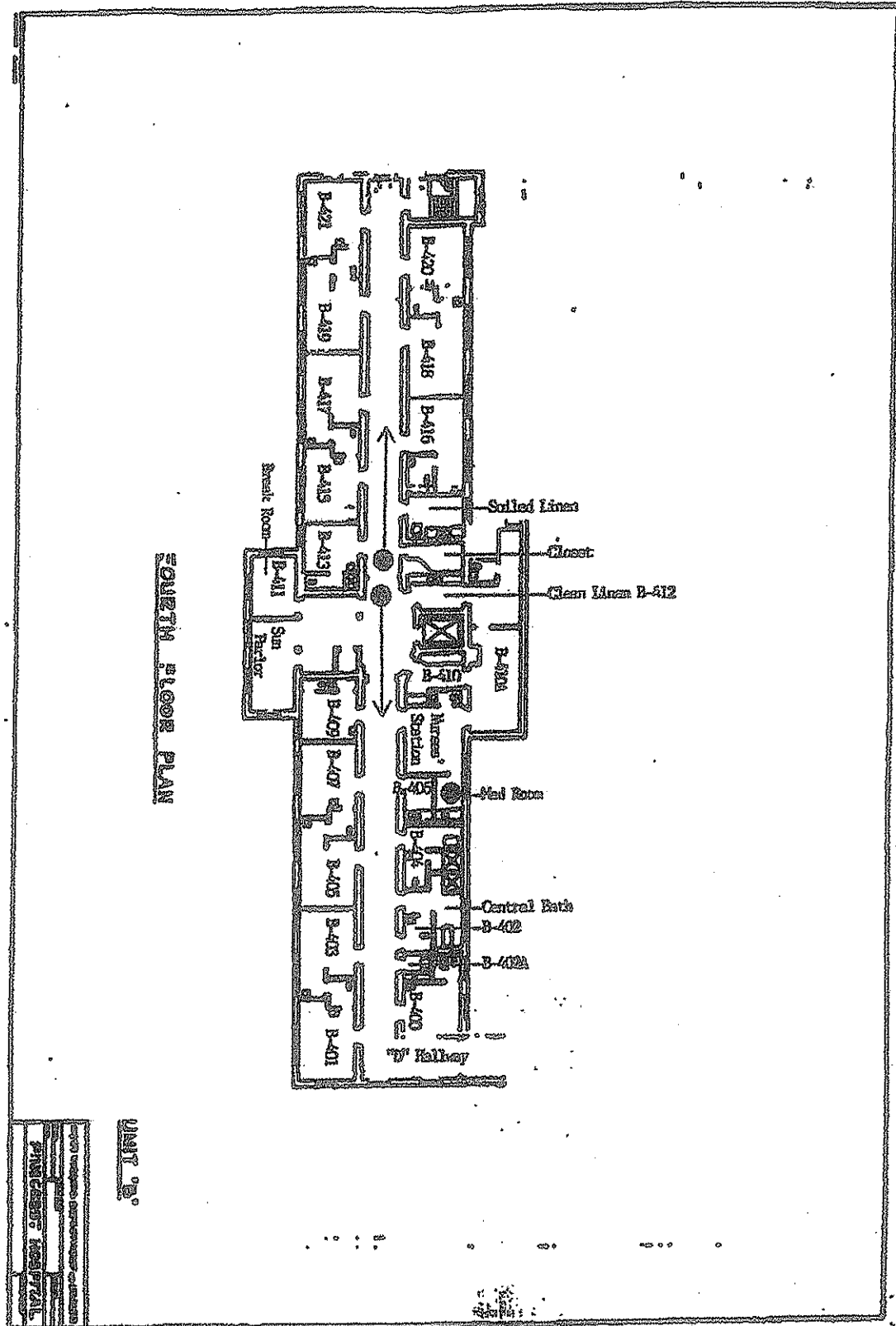

FOURTH FLOOR PLAN

UNIT "B"

UNIT "B"	FOURTH FLOOR PLAN
DATE: 07/19/55	BY: [Signature]
PROJECT: [Project Name]	SCALE: [Scale]
DESIGNER: [Designer Name]	REVISIONS: [List]
APPROVER: [Approver Name]	NOTES: [Notes]

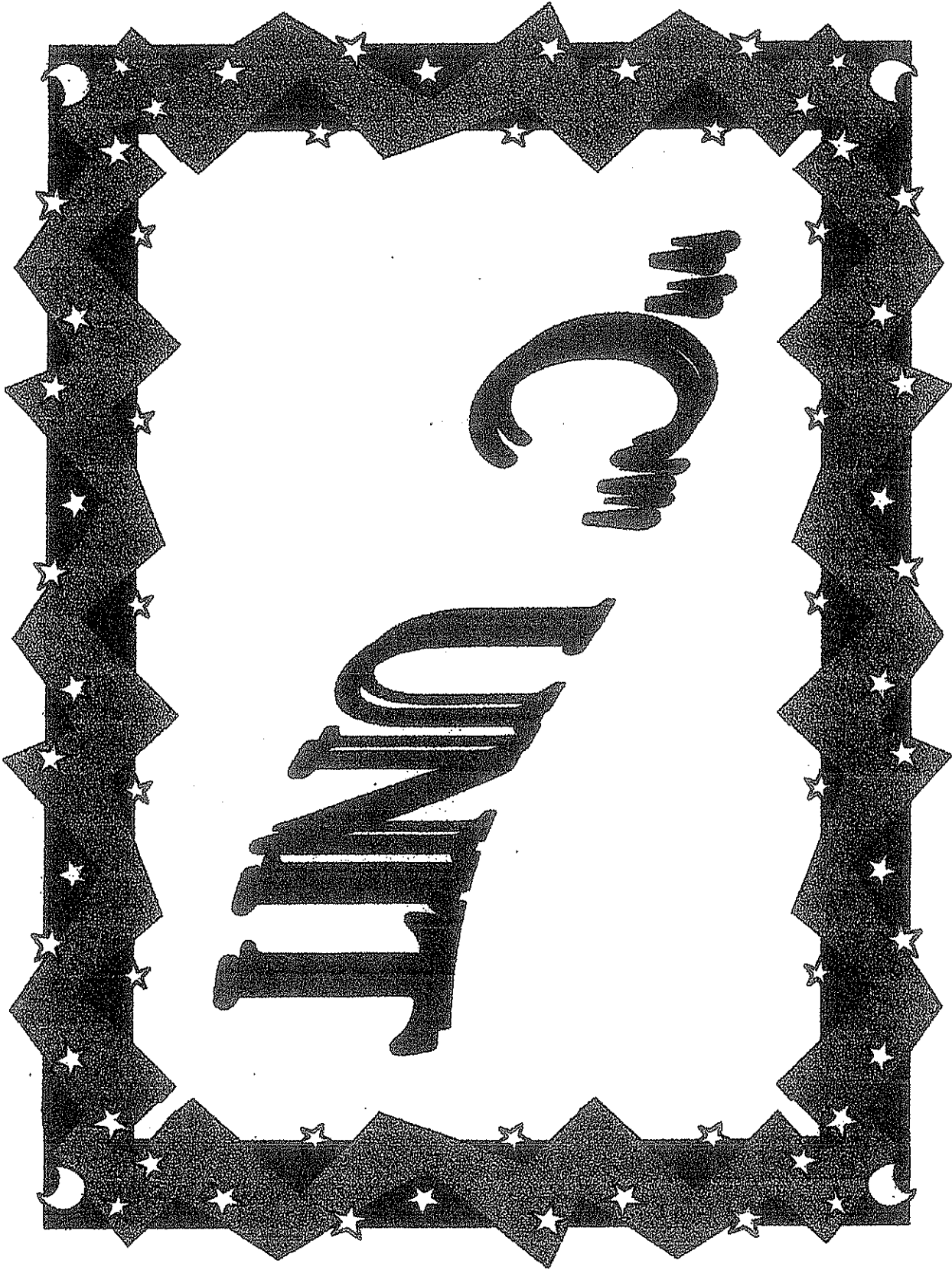

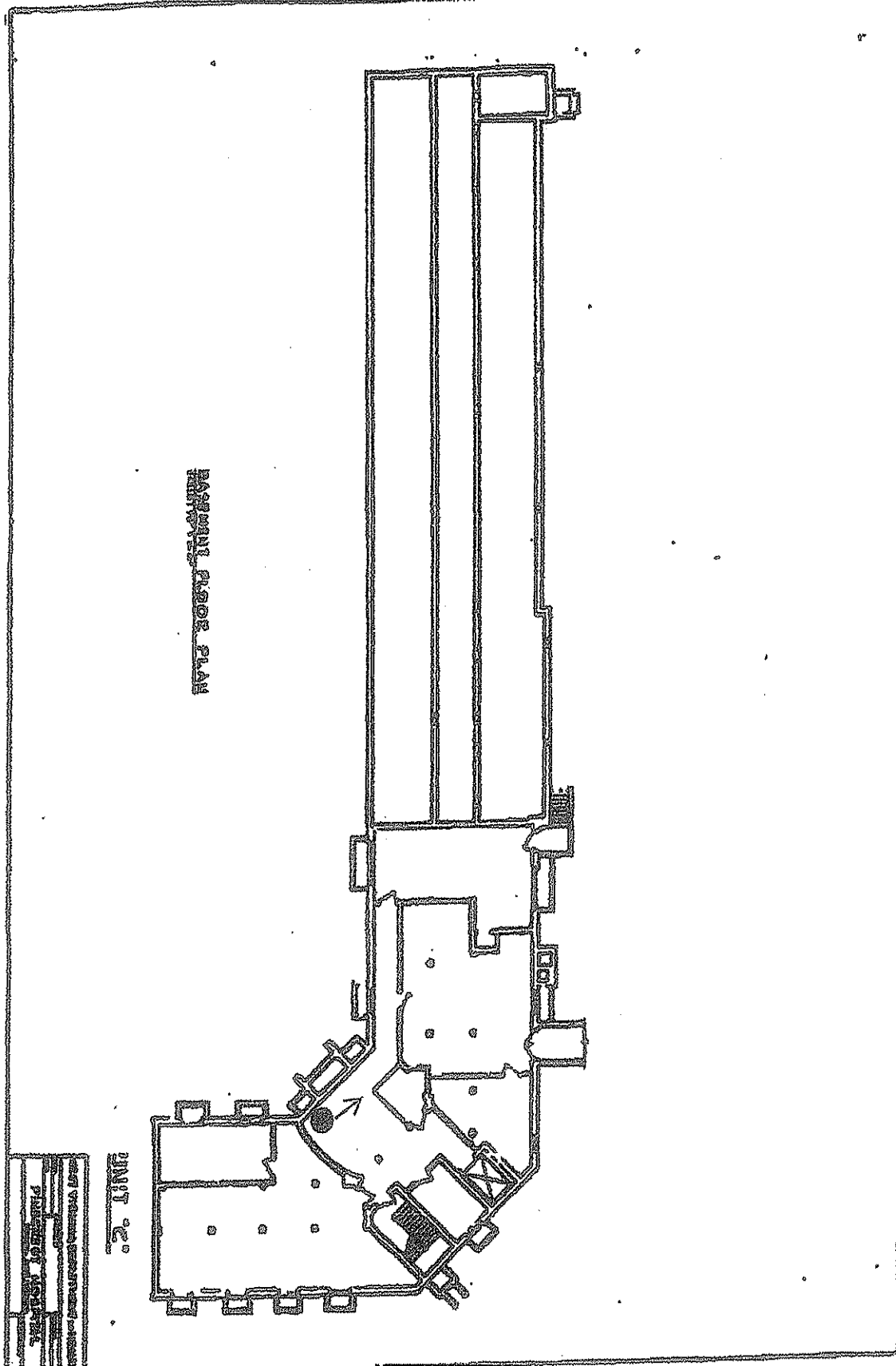

BASMENT FLOOR PLAN

UNIT 20

DATE	10/10/1984
BY	...
PROJECT	...
...	...

07/10/95 14:51 DHR-SUPPORT SERVICES + 256 6616

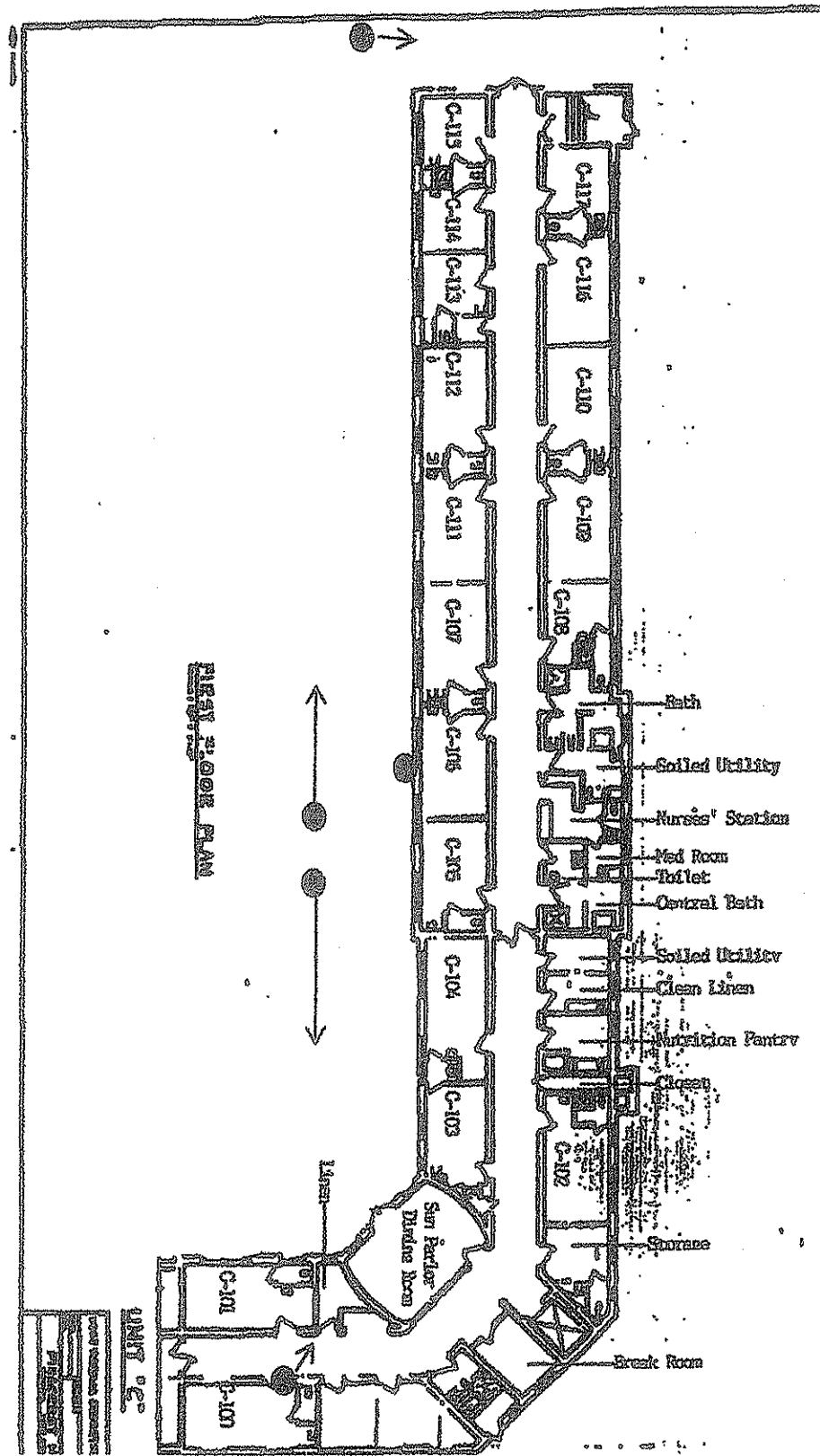

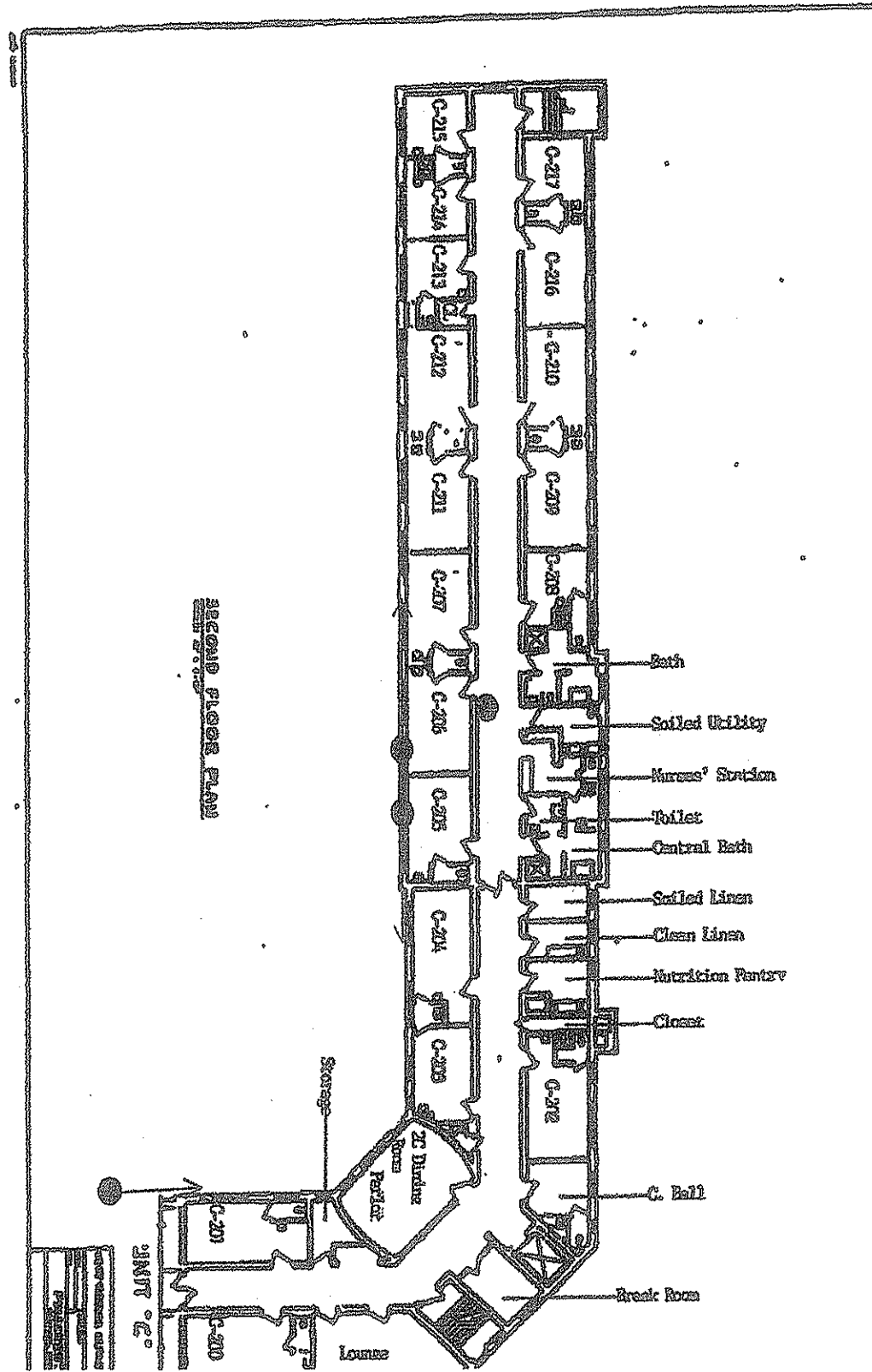

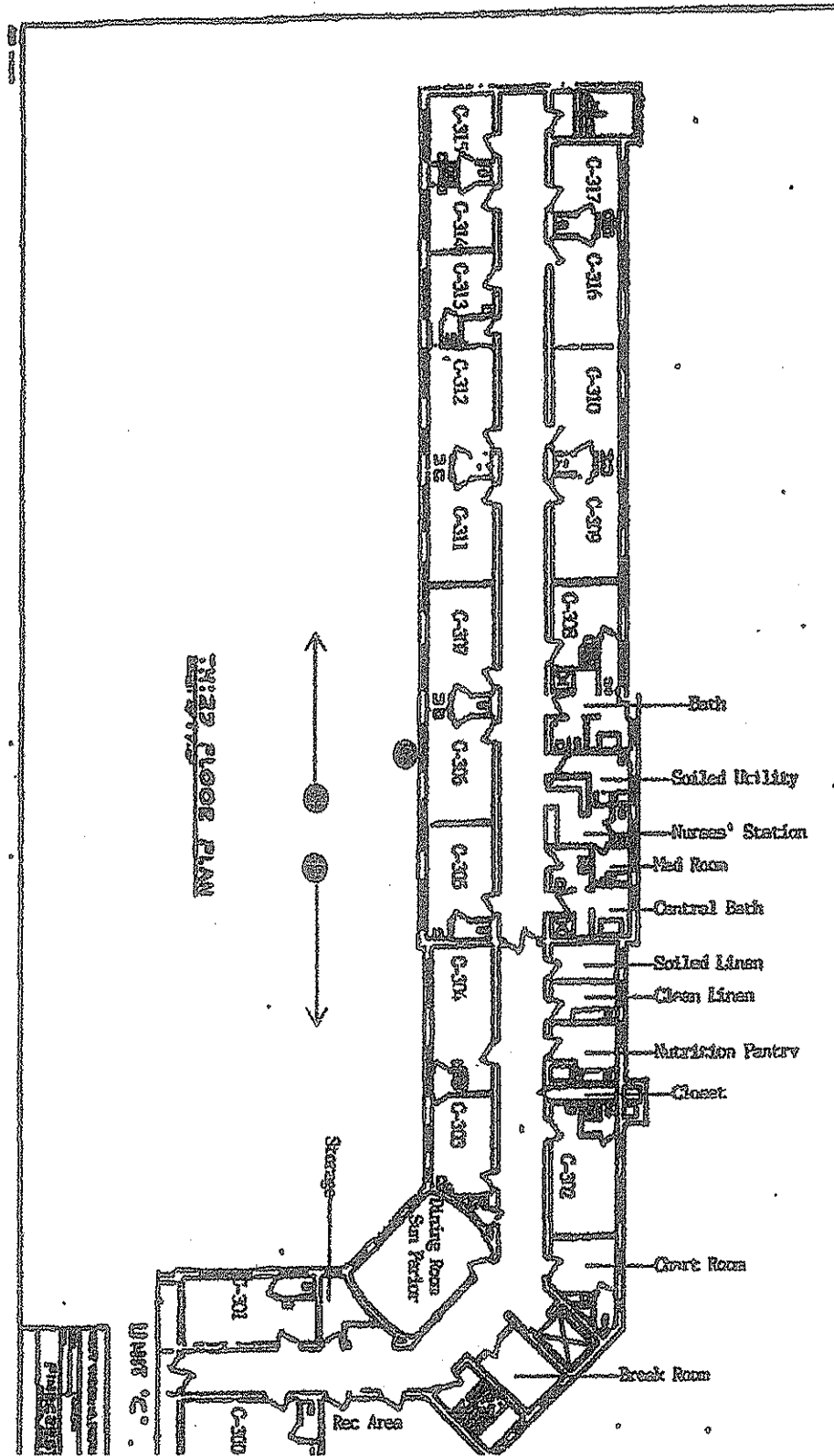

UNIT FLOOR PLAN

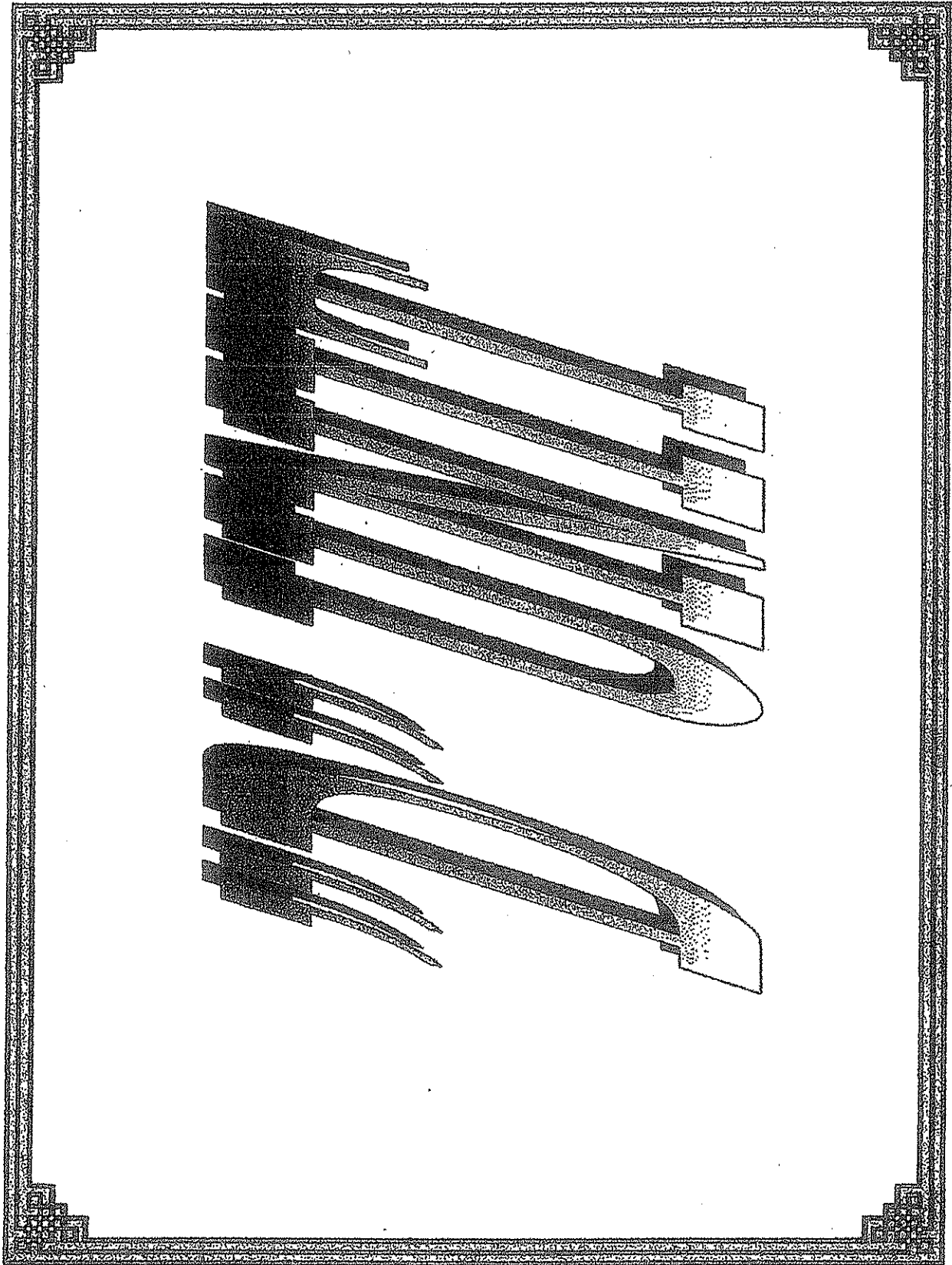

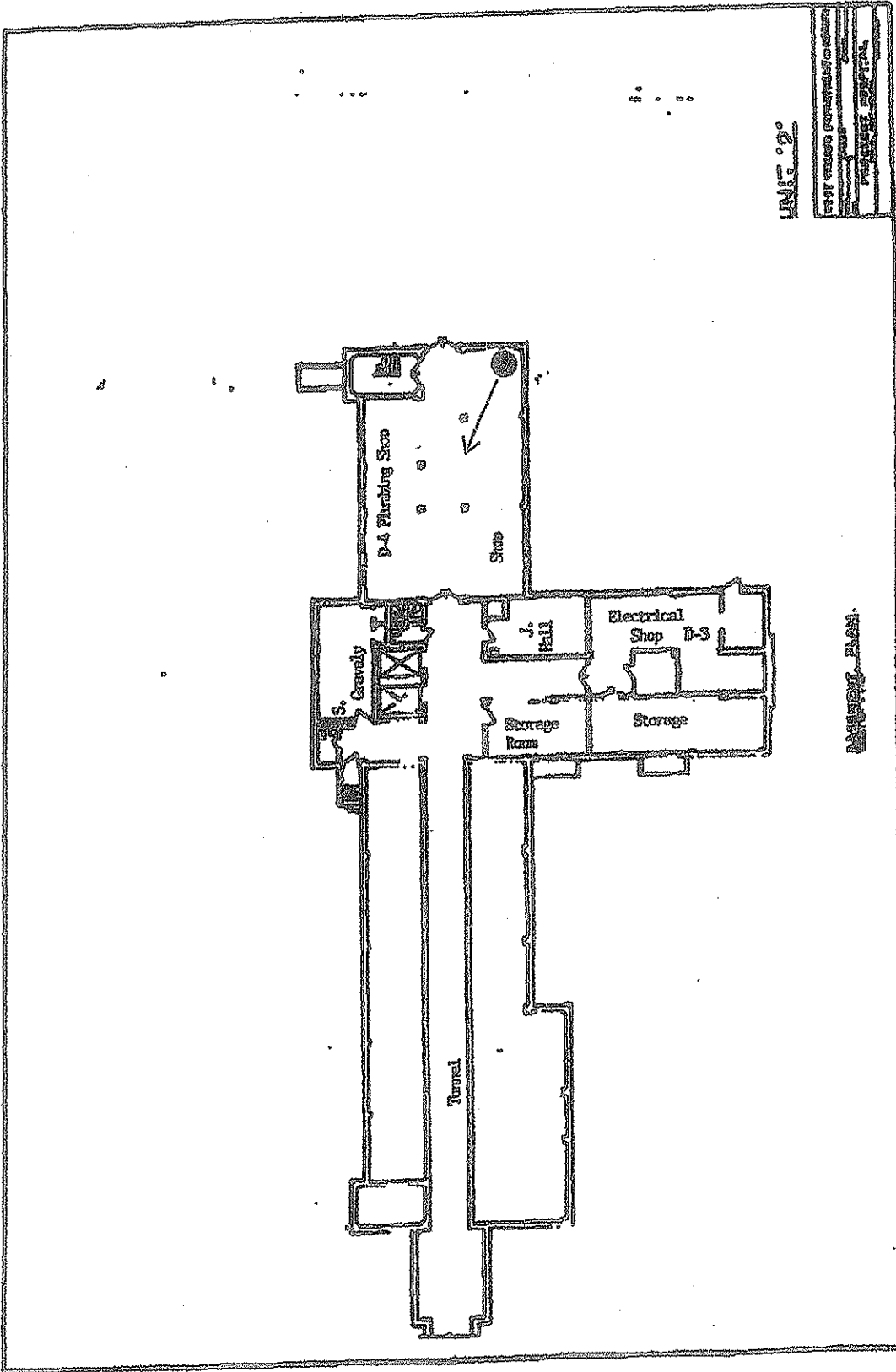

UNIT 020
 UNIT 02000 (02000) 02000
 UNIT 02000 (02000) 02000
 UNIT 02000 (02000) 02000

UNIT 02000 (02000) 02000

NO. 916

07/18/93 14:51 DMR-SUPPORT SERVICES + 255 6616

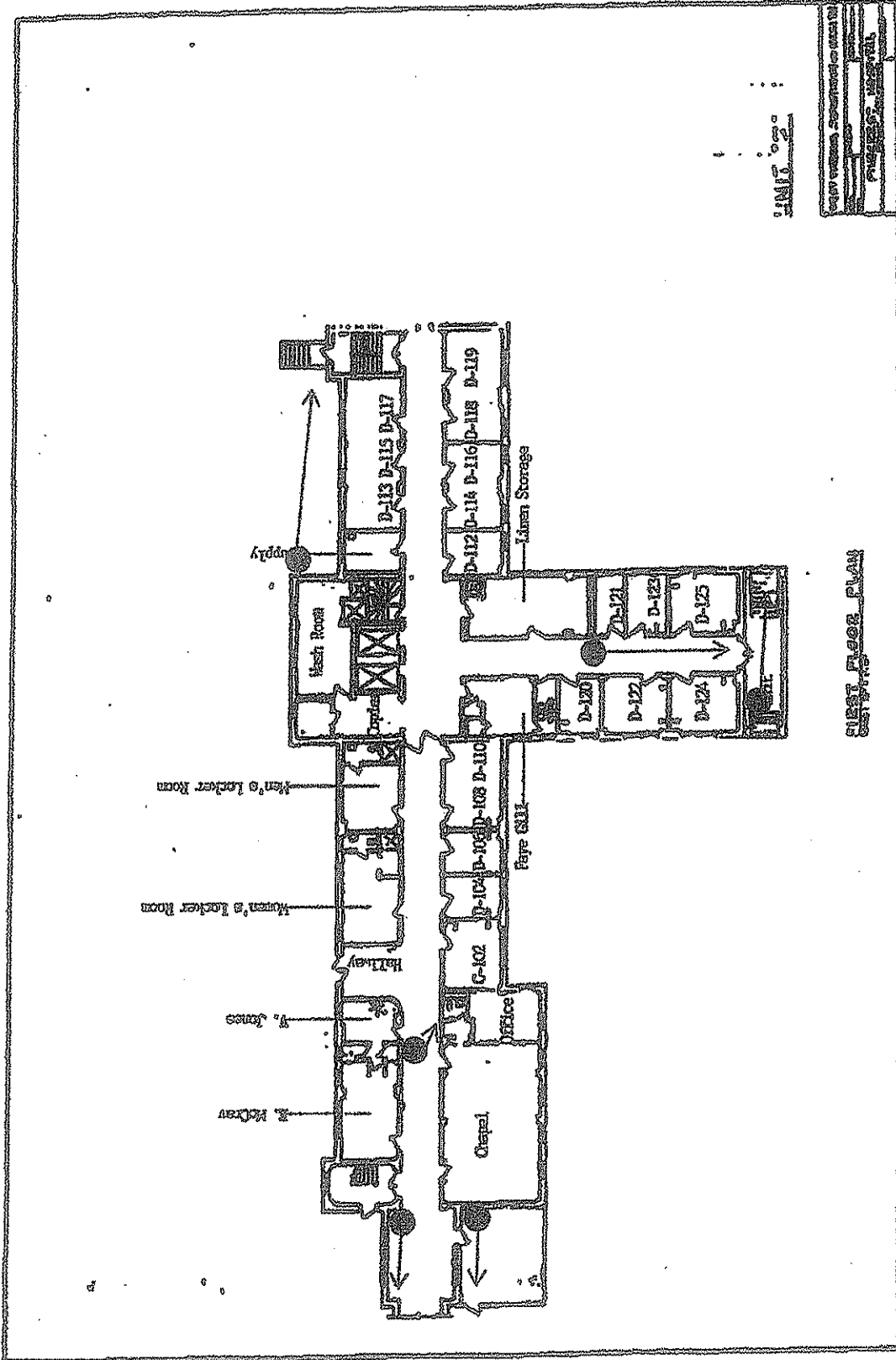

GUEST FLOOR PLAN

NO.:

07/18/98 14:52 D:\R-SUPPORT SERVICES - 256 6616

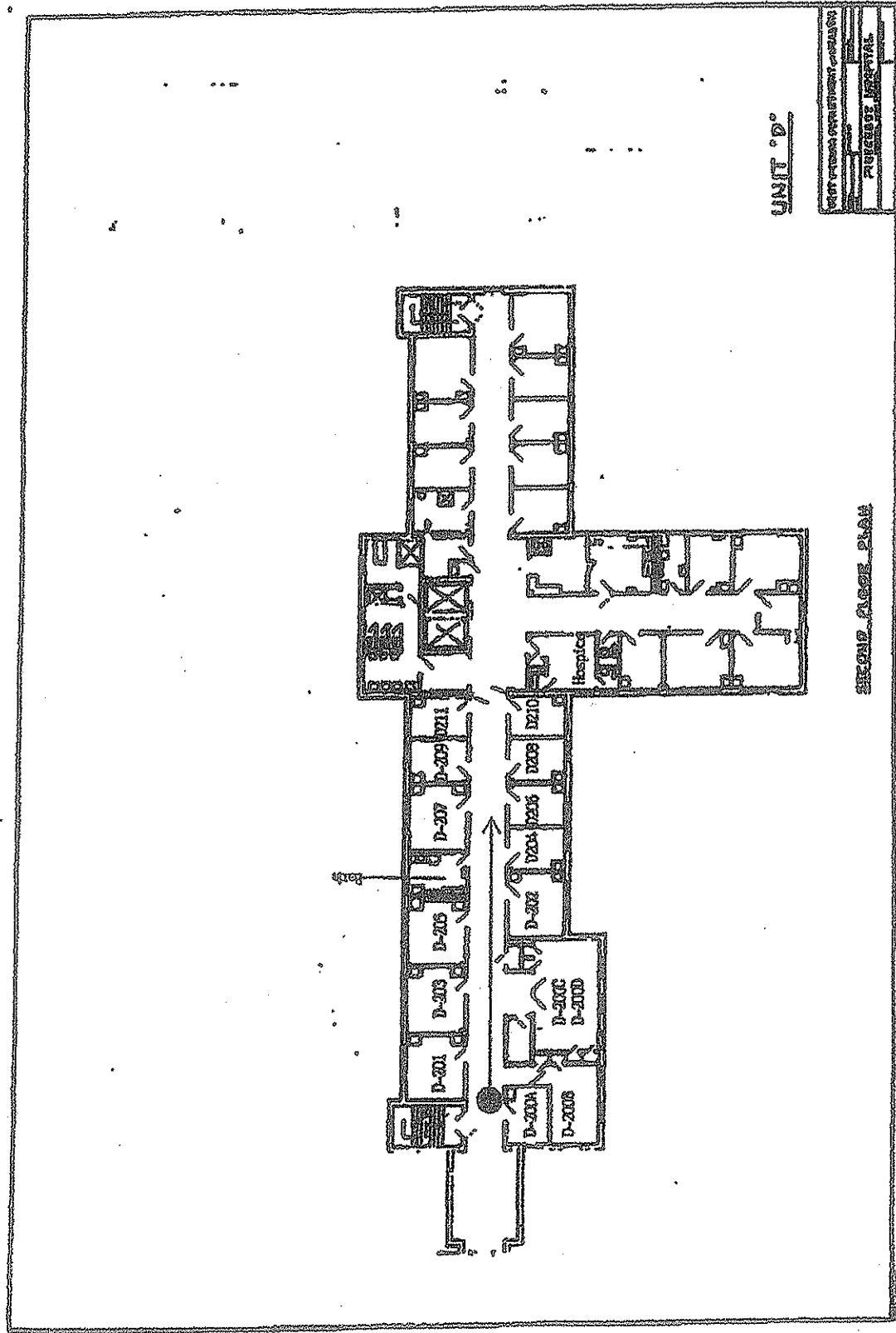

UNIT 'D'

PUGET SOUND HOSPITAL

SECOND FLOOR PLAN

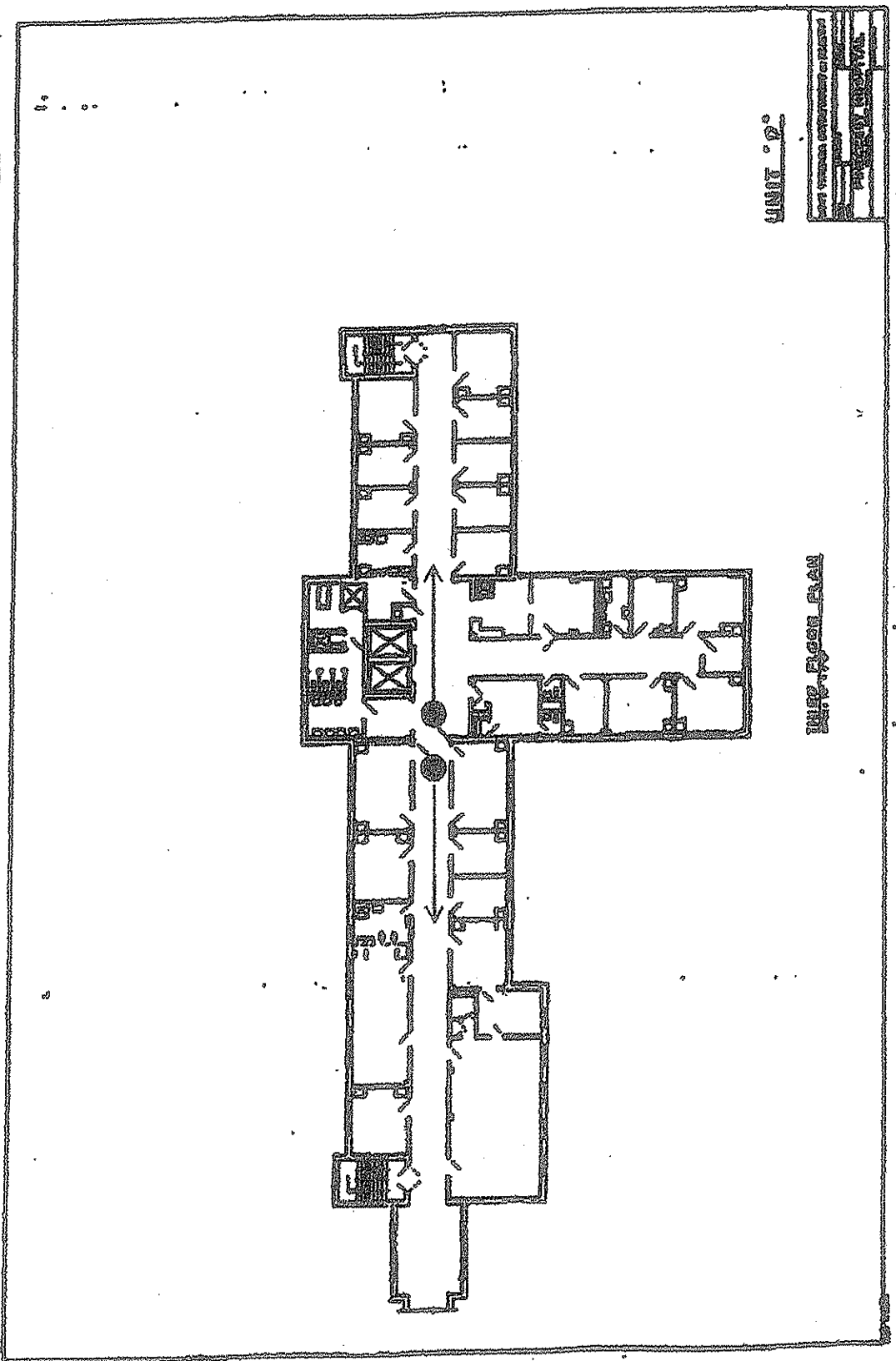

07/18/95 14:52 DMR-SUPPORT SERVICES - 236 5516 NO. 916 P021/025

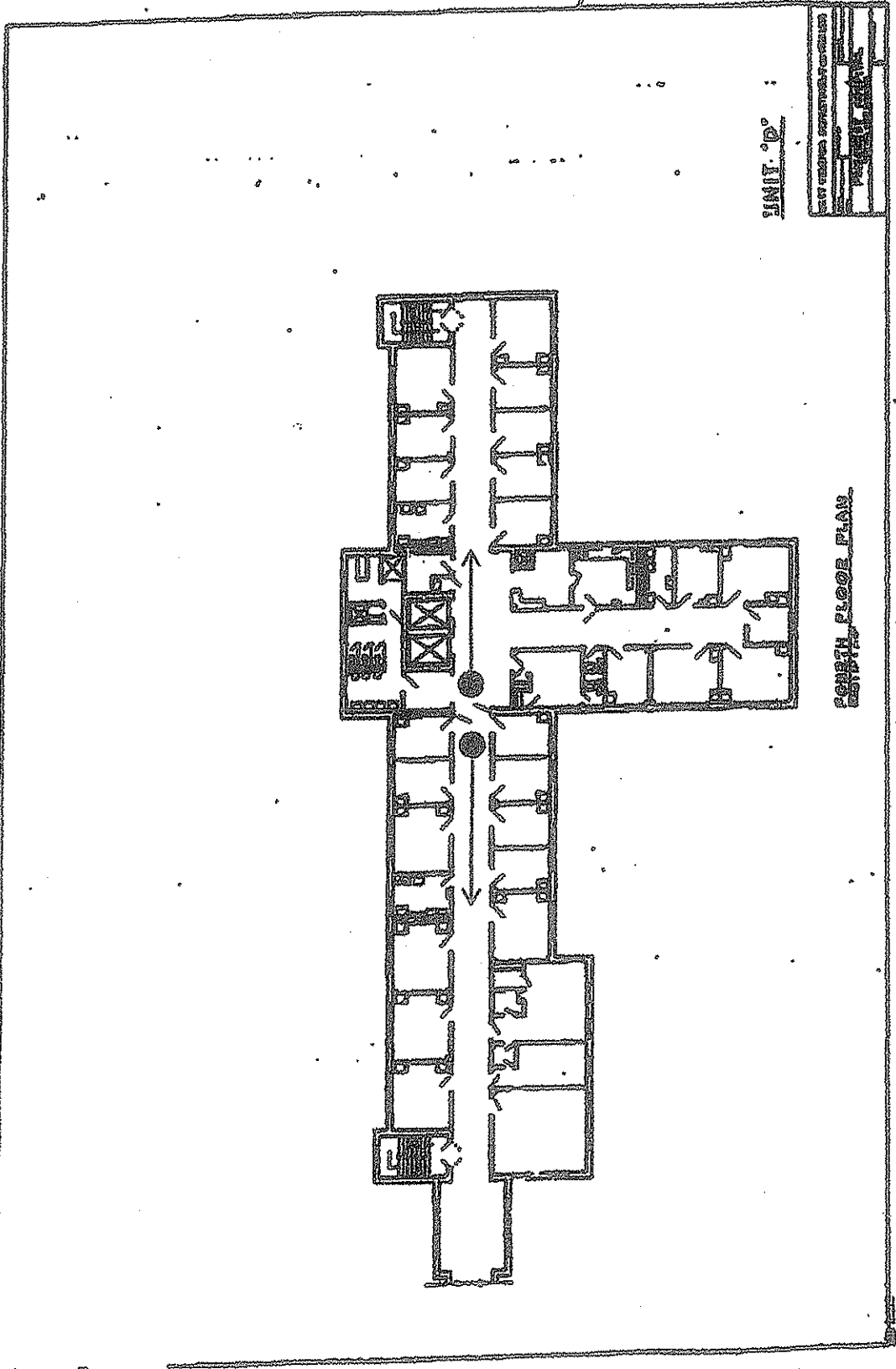

UNIT 'D'

NO. 916	PG. 23/25
DATE: 07/18/95	
BY: [Signature]	

SOUTH FLOOR PLAN

UNIT 0
PHI DELTA THETA
PHI DELTA THETA
PHI DELTA THETA
PHI DELTA THETA

UNIT 0

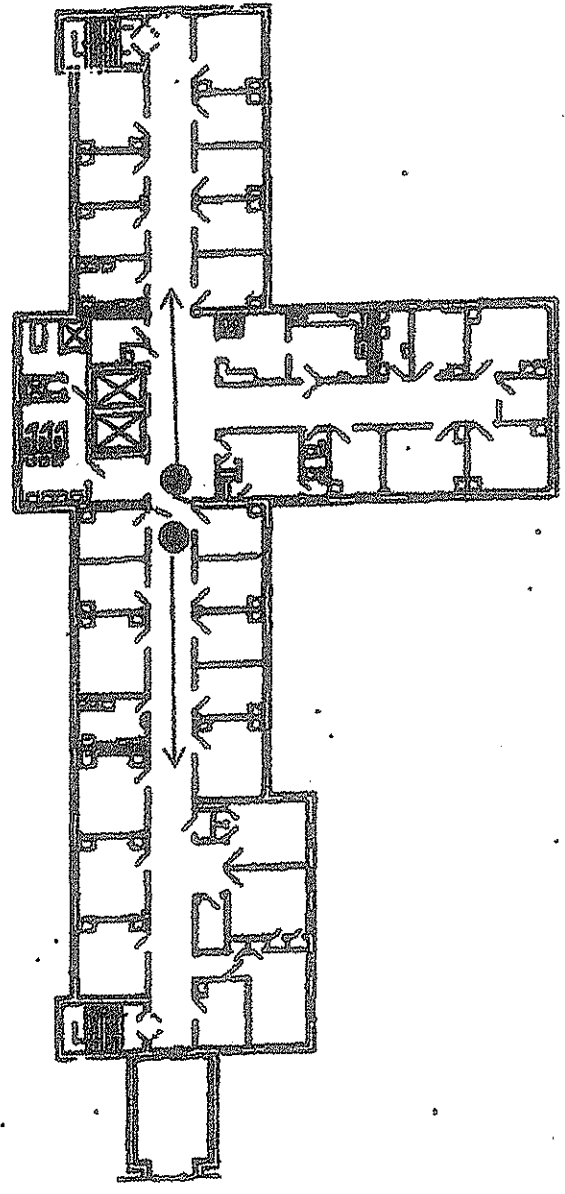

FLOOR PLAN

07/19/95 14:52 DHR-SUPPORT SERVICES - 255 6616 NO. 916 P024/025

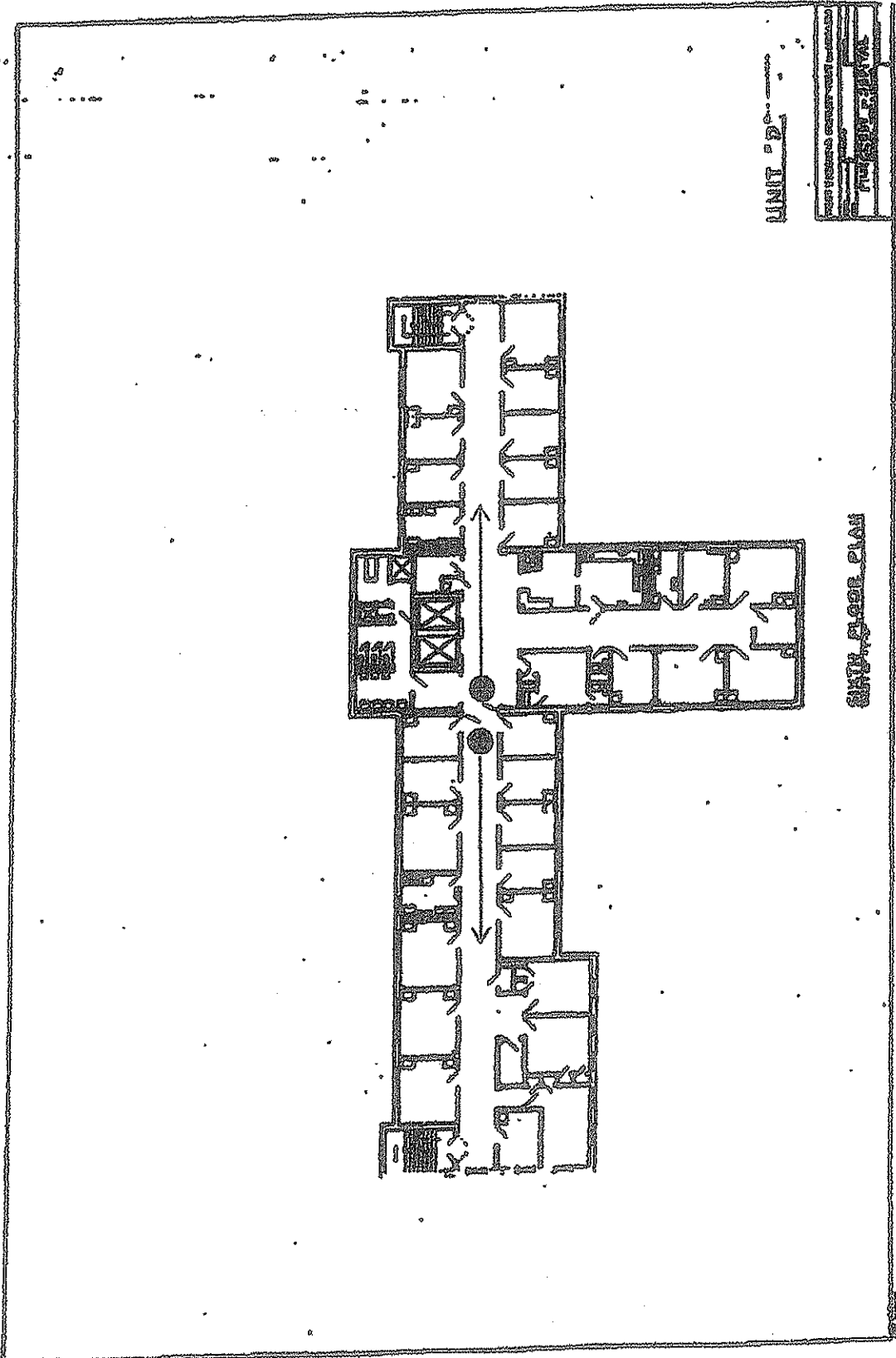

NO. 916 P025/025

07/18/53 14:32 I&R-SUPPORT SERVICES - 255 6616

RFQ No. PS1190126

STATE OF WEST VIRGINIA
Purchasing Division
PURCHASING AFFIDAVIT

VENDOR OWING A DEBT TO THE STATE:

West Virginia Code §5A-3-10a provides that: No contract or renewal of any contract may be awarded by the state or any of its political subdivisions to any vendor or prospective vendor when the vendor or prospective vendor or a related party to the vendor or prospective vendor is a debtor and the debt owed is an amount greater than one thousand dollars in the aggregate.

PUBLIC IMPROVEMENT CONTRACTS & DRUG-FREE WORKPLACE ACT:

If this is a solicitation for a public improvement construction contract, the vendor, by its signature below, affirms that it has a written plan for a drug-free workplace policy in compliance with Article 1D, Chapter 21 of the *West Virginia Code*. The vendor must make said affirmation with its bid submission. Further, public improvement construction contract may not be awarded to a vendor who does not have a written plan for a drug-free workplace policy in compliance with Article 1D, Chapter 21 of the *West Virginia Code* and who has not submitted that plan to the appropriate contracting authority in timely fashion. For a vendor who is a subcontractor, compliance with Section 5, Article 1D, Chapter 21 of the *West Virginia Code* may take place before their work on the public improvement is begun.

ANTITRUST:

In submitting a bid to any agency for the state of West Virginia, the bidder offers and agrees that if the bid is accepted the bidder will convey, sell, assign or transfer to the state of West Virginia all rights, title and interest in and to all causes of action it may now or hereafter acquire under the antitrust laws of the United States and the state of West Virginia for price fixing and/or unreasonable restraints of trade relating to the particular commodities or services purchased or acquired by the state of West Virginia. Such assignment shall be made and become effective at the time the purchasing agency tenders the initial payment to the bidder.

I certify that this bid is made without prior understanding, agreement, or connection with any corporation, firm, limited liability company, partnership or person or entity submitting a bid for the same materials, supplies, equipment or services and is in all respects fair and without collusion or fraud. I further certify that I am authorized to sign the certification on behalf of the bidder or this bid.

LICENSING:

Vendors must be licensed and in good standing in accordance with any and all state and local laws and requirements by any state or local agency of West Virginia, including, but not limited to, the West Virginia Secretary of State's Office, the West Virginia Tax Department, West Virginia Insurance Commission, or any other state agencies or political subdivision. Furthermore, the vendor must provide all necessary releases to obtain information to enable the Director or spending unit to verify that the vendor is licensed and in good standing with the above entities.

CONFIDENTIALITY:

The vendor agrees that he or she will not disclose to anyone, directly or indirectly, any such personally identifiable information or other confidential information gained from the agency, unless the individual who is the subject of the information consents to the disclosure in writing or the disclosure is made pursuant to the agency's policies, procedures and rules. Vendor further agrees to comply with the Confidentiality Policies and Information Security Accountability Requirements, set forth in <http://www.state.wv.us/admin/purchase/privacy/noticeConfidentiality.pdf>.

Under penalty of law for false swearing (*West Virginia Code §61-5-3*), it is hereby certified that the vendor affirms and acknowledges the information in this affidavit and is in compliance with the requirements as stated.

Vendor's Name: Pinnacle Electric, Inc.Authorized Signature: Date: 6/8/09



State of West Virginia
DRUG FREE WORKPLACE CONFORMANCE AFFIDAVIT
West Virginia Code §21-1D-5

STATE OF WEST VIRGINIA

COUNTY OF WOOD, TO-WIT:

I, KEVAN MEMEL, after being first duly sworn, depose and state as follows:

- 1. I am an employee of Pinnacle Electric, Inc.; and,
(Company Name)
- 2. I do hereby attest that Pinnacle Electric, Inc.
(Company Name)

maintains a valid written drug free workplace policy and that such policy is in compliance with *West Virginia Code §21-1D-5*.

The above statements are sworn to under the penalty of perjury.

Pinnacle Electric, Inc.
(Company Name)

By: KEVAN MEMEL

Title: Pinnacle Electric, Inc. / President

Date: _____

Taken, subscribed and sworn to before me this 9th day of June, 2009

By Commission expires 9-18-16

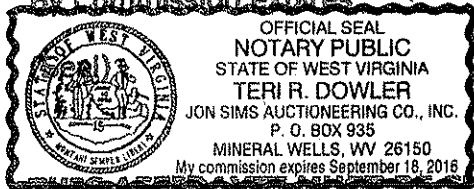

Teri R. Dowler
(Notary Public)

THIS AFFIDAVIT MUST BE SUBMITTED WITH THE BID IN ORDER TO COMPLY WITH WV CODE PROVISIONS. FAILURE TO INCLUDE THE AFFIDAVIT WITH THE BID SHALL RESULT IN DISQUALIFICATION OF THE BID.

ATTACHMENT
P.O.# PSH90126

This agreement constitutes the entire agreement between the parties, and there are no other terms and conditions applicable to the licenses granted hereunder.

Agreed
[Signature] 6/8/09
Signature Date
PRESIDENT
Title
Pinnacle Electric, Inc.
Company Name

Signature Date

Title

Agency/Division

WV-96
Rev. 10/07

AGREEMENT ADDENDUM

In the event of conflict between this addendum and the agreement, this addendum shall control:

1. **DISPUTES** - Any references in the agreement to arbitration or to the jurisdiction of any court are hereby deleted. Disputes arising out of the agreement shall be presented to the West Virginia Court of Claims.
2. **HOLD HARMLESS** - Any clause requiring the Agency to indemnify or hold harmless any party is hereby deleted in its entirety.
3. **GOVERNING LAW** - The agreement shall be governed by the laws of the State of West Virginia. This provision replaces any references to any other State's governing law.
4. **TAXES** - Provisions in the agreement requiring the Agency to pay taxes are deleted. As a State entity, the Agency is exempt from Federal, State, and local taxes and will not pay taxes for any Vendor including individuals, nor will the Agency file any tax returns or reports on behalf of Vendor or any other party.
5. **PAYMENT** - Any references to prepayment are deleted. Payment will be in arrears.
6. **INTEREST** - Should the agreement include a provision for interest on late payments, the Agency agrees to pay the maximum legal rate under West Virginia law. All other references to interest or late charges are deleted.
7. **RECOUPMENT** - Any language in the agreement waiving the Agency's right to set-off, counterclaim, recoupment, or other defense is hereby deleted.
8. **FISCAL YEAR FUNDING** - Service performed under the agreement may be continued in succeeding fiscal years for the term of the agreement, contingent upon funds being appropriated by the Legislature or otherwise being available for this service. In the event funds are not appropriated or otherwise available for this service, the agreement shall terminate without penalty on June 30. After that date, the agreement becomes of no effect and is null and void. However, the Agency agrees to use its best efforts to have the amounts contemplated under the agreement included in its budget. Non-appropriation or non-funding shall not be considered an event of default.
9. **STATUTE OF LIMITATION** - Any clauses limiting the time in which the Agency may bring suit against the Vendor, lessor, individual, or any other party are deleted.
10. **SIMILAR SERVICES** - Any provisions limiting the Agency's right to obtain similar services or equipment in the event of default or non-funding during the term of the agreement are hereby deleted.
11. **ATTORNEY FEES** - The Agency recognizes an obligation to pay attorney's fees or costs only when assessed by a court of competent jurisdiction. Any other provision is invalid and considered null and void.
12. **ASSIGNMENT** - Notwithstanding any clause to the contrary, the Agency reserves the right to assign the agreement to another State of West Virginia agency, board or commission upon thirty (30) days written notice to the Vendor and Vendor shall obtain the written consent of Agency prior to assigning the agreement.
13. **LIMITATION OF LIABILITY** - The Agency, as a State entity, cannot agree to assume the potential liability of a Vendor. Accordingly, any provision limiting the Vendor's liability for direct damages to a certain dollar amount or to the amount of the agreement is hereby deleted. Limitations on special, incidental or consequential damages are acceptable. In addition, any limitation is null and void to the extent that it precludes any action for injury to persons or for damages to personal property.
14. **RIGHT TO TERMINATE** - Agency shall have the right to terminate the agreement upon thirty (30) days written notice to Vendor. Agency agrees to pay Vendor for services rendered or goods received prior to the effective date of termination.
15. **TERMINATION CHARGES** - Any provision requiring the Agency to pay a fixed amount or liquidated damages upon termination of the agreement is hereby deleted. The Agency may only agree to reimburse a Vendor for actual costs incurred or losses sustained during the current fiscal year due to wrongful termination by the Agency prior to the end of any current agreement term.
16. **RENEWAL** - Any reference to automatic renewal is hereby deleted. The agreement may be renewed only upon mutual written agreement of the parties.
17. **INSURANCE** - Any provision requiring the Agency to insure equipment or property of any kind and name the Vendor as beneficiary or as an additional insured is hereby deleted.
18. **RIGHT TO NOTICE** - Any provision for repossession of equipment without notice is hereby deleted. However, the Agency does recognize a right of repossession with notice.
19. **ACCELERATION** - Any reference to acceleration of payments in the event of default or non-funding is hereby deleted.
20. **CONFIDENTIALITY** - Any provision regarding confidentiality of the terms and conditions of the agreement is hereby deleted. State contracts are public records under the West Virginia Freedom of Information Act.
21. **AMENDMENTS** - All amendments, modifications, alterations or changes to the agreement shall be in writing and signed by both parties. No amendment, modification, alteration or change may be made to this addendum without the express written approval of the Purchasing Division and the Attorney General.

ACCEPTED BY:

STATE OF WEST VIRGINIA

Spending Unit: _____

Signed: _____

Title: _____

Date: _____

VENDOR

Company Name: Pinnacle Electric, Inc

Signed: _____

Title: PRESIDENT

Date: 6/8/09

ACORD CERTIFICATE OF LIABILITY INSURANCE

OP ID TW
PINNA-1

DATE (MM/DD/YYYY)
06/08/09

PRODUCER Schwendeman Agency Inc. 109 Putnam Street Marietta OH 45750 Phone: 740-373-6793 Fax: 740-373-7850		THIS CERTIFICATE IS ISSUED AS A MATTER OF INFORMATION ONLY AND CONFERS NO RIGHTS UPON THE CERTIFICATE HOLDER. THIS CERTIFICATE DOES NOT AMEND, EXTEND OR ALTER THE COVERAGE AFFORDED BY THE POLICIES BELOW.	
INSURED Pinnacle Electric, Inc. Kevan Memel 817 19th Street Parkersburg WV 26101		INSURERS AFFORDING COVERAGE	NAIC #
		INSURER A: State Auto Insurance Companies	
		INSURER B:	
		INSURER C:	
		INSURER D:	
		INSURER E:	

COVERAGES

THE POLICIES OF INSURANCE LISTED BELOW HAVE BEEN ISSUED TO THE INSURED NAMED ABOVE FOR THE POLICY PERIOD INDICATED. NOTWITHSTANDING ANY REQUIREMENT, TERM OR CONDITION OF ANY CONTRACT OR OTHER DOCUMENT WITH RESPECT TO WHICH THIS CERTIFICATE MAY BE ISSUED OR MAY PERTAIN, THE INSURANCE AFFORDED BY THE POLICIES DESCRIBED HEREIN IS SUBJECT TO ALL THE TERMS, EXCLUSIONS AND CONDITIONS OF SUCH POLICIES. AGGREGATE LIMITS SHOWN MAY HAVE BEEN REDUCED BY PAID CLAIMS.

INSR ADD'L LTR INSRD	TYPE OF INSURANCE	POLICY NUMBER	POLICY EFFECTIVE DATE (MM/DD/YY)	POLICY EXPIRATION DATE (MM/DD/YY)	LIMITS	
A	GENERAL LIABILITY <input type="checkbox"/> COMMERCIAL GENERAL LIABILITY <input type="checkbox"/> CLAIMS MADE <input type="checkbox"/> OCCUR GEN'L AGGREGATE LIMIT APPLIES PER: <input type="checkbox"/> POLICY <input type="checkbox"/> PRO-JECT <input type="checkbox"/> LOC	PENDING	10/31/08	10/31/09	EACH OCCURRENCE	\$ 1,000,000
	DAMAGE TO RENTED PREMISES (Ea occurrence)				\$ 100,000	
					MED EXP (Any one person)	\$ 5,000
					PERSONAL & ADV INJURY	\$ 1,000,000
					GENERAL AGGREGATE	\$ 2,000,000
					PRODUCTS - COMP/OP AGG	\$ 2,000,000
	AUTOMOBILE LIABILITY <input type="checkbox"/> ANY AUTO <input type="checkbox"/> ALL OWNED AUTOS <input type="checkbox"/> SCHEDULED AUTOS <input type="checkbox"/> HIRED AUTOS <input type="checkbox"/> NON-OWNED AUTOS				COMBINED SINGLE LIMIT (Ea accident)	\$
					BODILY INJURY (Per person)	\$
					BODILY INJURY (Per accident)	\$
					PROPERTY DAMAGE (Per accident)	\$
	GARAGE LIABILITY <input type="checkbox"/> ANY AUTO				AUTO ONLY - EA ACCIDENT	\$
					OTHER THAN AUTO ONLY: EA ACC	\$
					AGG	\$
	EXCESS/UMBRELLA LIABILITY <input type="checkbox"/> OCCUR <input type="checkbox"/> CLAIMS MADE DEDUCTIBLE RETENTION \$				EACH OCCURRENCE	\$
					AGGREGATE	\$
						\$
						\$
	WORKERS COMPENSATION AND EMPLOYERS' LIABILITY ANY PROPRIETOR/PARTNER/EXECUTIVE OFFICER/MEMBER EXCLUDED? If yes, describe under SPECIAL PROVISIONS below				WC STATUTORY LIMITS	OTHER
					E.L. EACH ACCIDENT	\$
					E.L. DISEASE - EA EMPLOYEE	\$
					E.L. DISEASE - POLICY LIMIT	\$
	OTHER				Cargo	5000
					Tools	8000

DESCRIPTION OF OPERATIONS / LOCATIONS / VEHICLES / EXCLUSIONS ADDED BY ENDORSEMENT / SPECIAL PROVISIONS
Electrical Electrical

CERTIFICATE HOLDER State of West Virginia Charleston WV	CANCELLATION SHOULD ANY OF THE ABOVE DESCRIBED POLICIES BE CANCELLED BEFORE THE EXPIRATION DATE THEREOF, THE ISSUING INSURER WILL ENDEAVOR TO MAIL 10 DAYS WRITTEN NOTICE TO THE CERTIFICATE HOLDER NAMED TO THE LEFT, BUT FAILURE TO DO SO SHALL IMPOSE NO OBLIGATION OR LIABILITY OF ANY KIND UPON THE INSURER, ITS AGENTS OR REPRESENTATIVES. AUTHORIZED REPRESENTATIVE Tonya E. Tullius <i>Tonya E. Tullius</i>
--	---



Pinecrest Hospital - CCTV Submittal Package

The following is a product submittal for the CCTV needed for this project. This submittal is intended as a general guideline for the materials needed to complete this job.

**Dan Vandegrift – SESCO Data/Com
6/9/2009**

GANZ

DIGIMASTER

4, 8 & 16 CHANNEL DVRs **120 IPS**

The Ganz DIGIMASTER Series is a powerful line of Digital Video Recorders designed to provide state-of-the-art features, exceptional recorded image quality and ease of operation. With up to 3 TB of internal storage capacity, this series provides more than 60 days recording time at 704 x 480 resolution. MPEG-4 compression saves high-quality images with smaller file sizes and allows more efficient transmission over Ethernet. USB-2 ports and an optional DVD drive assure quick and easy archiving.

- 4/8/16 ch video and 4 ch audio recording
- 120 images per second recording speed
- True TRIPLEX operation
- Up to 704 x 480 (4 CIF/D1) resolution
- Optimized MPEG-4 compression
- 10/100 Base T Network Connection allows remote viewing, playback and PTZ control
- Mouse control through USB port
- USB-2 port for quick downloading to a thumb drive
- Internal DVD drive for data backup (optional)
- PTZ control (drivers for most popular models included)
- Panic button recording mode with adjustable settings per channel
- Hard disk drives engineered for Digital Video Surveillance optimize performance and improve reliability

3.0 TB



3/5
Year
Warranty
3 Years on DVR/
5 Years on Hard Disk Drive



CBC (AMERICA) Corp.

NY: 1-800-422-6707

CA: 1-800-888-0131

www.computarganz.com

features+highlights

DIGIMASTER 4, 8 and 16 channel MPEG-4 DVRs are compact, versatile, and very powerful. The units provide 'always-on' recording capability, with variable resolution, image quality, image rate, and audio recording; all are adjustable per channel. This series has several recording modes, including schedule, motion, alarm and panic button recording, each with individually adjustable settings per channel. The units have strong networking and data archiving features, along with a handheld IR Remote Controller and a USB Thumb Drive included with each unit. DIGIMASTER boasts a large storage capacity and an optional internal DVD burner. MPEG-4 compression reduces HDD consumption, yet allows for excellent image reproduction, at any resolution. The easy-to-use, yet powerful GUI ties it all together with organized menu navigation and strong administration features.

DIGIMASTER

Line-of-sight operation with handheld controller (included)

Internal DVD drive (optional)

Panic Button triggers special emergency recording settings

Intuitive, easy-to-navigate GUI and menu system

Jog /Shuttle wheel for easier searching

Up to 16 channels of high resolution digital video recording and retrieval

Two (2) Front Panel USB-2 ports for quick easy archiving of still images or full-motion video and sync audio

Archive Audio and Video to DVD writer or USB Thumb Drive

Search by Event or a specific Date/Time

Supports most popular PTZ devices, with Preset and Tour functions

Handheld Remote and Thumb Drive included

Up to 16 channels of BNC video inputs and Hi-Z Loop outs

BNC and S-Video main monitor outputs

Four (4) individually sequenced spot monitor outputs

4 channels of audio recording, with remote audio monitoring and bi-directional audio transmission via network/LAN and client PC

Up to 16 analog alarm inputs and up to 16 Relay Outputs, all adjustable as N/D or N/C

3rd USB-2 port on rear panel

VGA out

RS-485 Interface supports most PTZ devices & protocols

RJ-45 10/100 Ethernet LAN capability

100-220VAC power input

CAUTION HIGH VOLTAGE

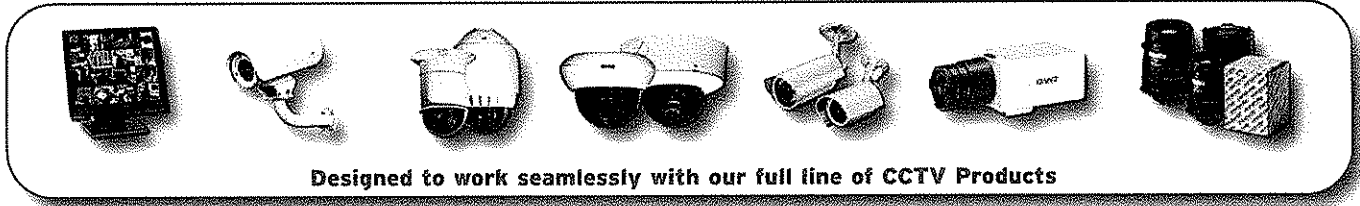

system configuration

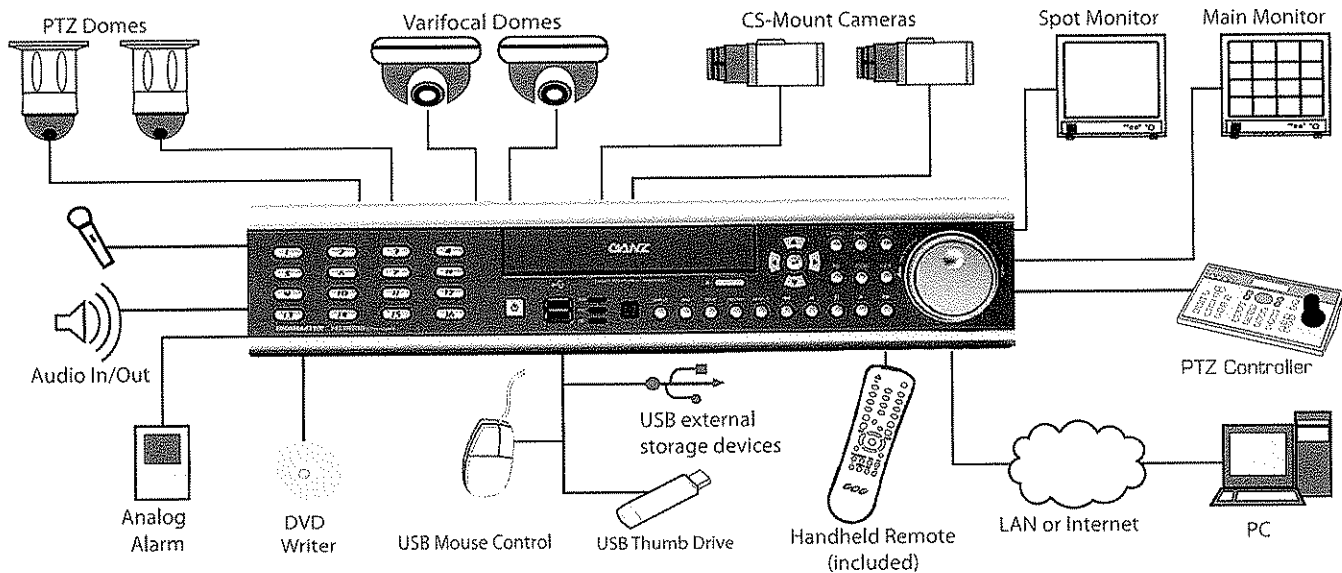

Designed to work within a variety of system configurations, these units fit easily into your existing CCTV infrastructure. With a built-in RS-485 serial interface, the DIGIMASTER operates most of the popular PTZ devices on the market. The DIGIMASTER features integrated motion detection with live view motion area marking, analog alarm inputs and relay outputs, pre- and post-alarm recording buffers, and e-mail notification of alarm and system events. Strong networking features include remote PTZ control, live view, event log search, remote configuration, multi-channel playback, and remote download of archive video and audio data. Each unit has advanced management and scheduling features, automatic Daylight Savings Time adjustment, and support for continuous time correction via Network Time Protocol (NTP). Password protection and selectable covert channel recording effectively restrict access to authorized users only.

recording times

(shown in days using a 500 GB HDD-8/16 ch, 250 GB HDD-4 ch. See website for additional times)

4 Channel	CIF (352x240)				2CIF (704x240)				4CIF (704x480)				
		Highest	High	Standard	Low	Highest	High	Standard	Low	Highest	High	Standard	Low
	15 ips	14	15	24	32	8	9	15	17	-	-	-	-
	7 ips	13	20	30	38	10	11	16	20	4.5	5	7	9
1 ips	44	50	73	90	24	27	36	44	12	15	18	22	

8 Channel	CIF (352x240)				2CIF (704x240)				4CIF (704x480)				
		Highest	High	Standard	Low	Highest	High	Standard	Low	Highest	High	Standard	Low
	15 ips	11.2	17.5	22.1	26.9	10.3	17.8	23.2	27	11.9	17.8	25	29.8
	7 ips	17.6	20	29.6	38.4	6.6	10.1	12.8	15.1	7.1	10.1	13.3	16
1 ips	43.6	49.6	52.8	90.4	23.6	26.8	36.4	44	11.6	13.2	18	22.4	

16 Channel	CIF (352x240)				2CIF (704x240)				4CIF (704x480)				
		Highest	High	Standard	Low	Highest	High	Standard	Low	Highest	High	Standard	Low
	15 ips	11.2	17.5	22.1	26.9	10.3	17.8	23.2	27	11.9	17.8	25	29.8
	7 ips	8.9	10	14.3	19.2	6.6	10.1	12.8	15.1	7.1	10.1	13.3	16
1 ips	21.8	24.6	26.4	45.2	11.8	13.4	18.2	22	5.5	6.6	9	11.2	

Color Legend (maximum channels available at specified image rates)

up to 16 ch
 up to 8 ch
 up to 4 ch
 only 2 ch

Specifications

Video Standard	NTSC or PAL (switchable)
Monitor Display	Real Time 30FPS (NTSC) Per Camera
Operating System	Embedded Linux
Record Scheduling	Daily, weekly, adjustable to specific hour per channel
Record Mode	Continuous, Motion, Event, Panic
Remote Access	TCP/IP, View, Search, Recording and Control (client software or browser)
Playback	Up to 16 channel simultaneous playback
Pre/Post Alarm	5 Secs (Pre), 3 Mins (Post), programmable per camera
VGA Output	Standard (for monitors with multi-sync function only) (1024 x 768, 60Hz)
Motion Detection	16 x 16 Grid, Sensitivity Levels: 10
DVR Operation	Triplex
Video Inputs	16 Ch - 16 inputs, 1Vp-p, CVBS, 75 ohms, BNC 8 Ch - 8 inputs, 1Vp-p, CVBS, 75 ohms, BNC 4 Ch - 4 inputs, 1Vp-p, CVBS, 75 ohms, BNC
Video Outputs	16 Ch - 16 looping outputs 8 Ch - 8 looping outputs 4 Ch - 4 looping outputs
Monitor Outputs	1 x BNC Composite Video, S-VHS and VGA
Spot Output	16 Ch - 4 x 1Vp-p, CVBS, 75 ohms, BNC 8 Ch - 2 x 1Vp-p, CVBS, 75 ohms, BNC 4 Ch - 1 x 1Vp-p, CVBS, 75 ohms, BNC
Audio Inputs	4 x line-in, RCA
Audio Output	1 x line-out, RCA
Screen Options	16 Ch - 1, 4, 6, 8, 9, 13, 16 8 Ch - 1, 4, 6, 8 4 Ch - 1, 4
Resolution	352x240, 704x240, 704x480 (NTSC)
Compression Standard	MPEG-4
Recording Speed (ips)	352x240: 120 ips, 704x240: 60 ips, 704x480: 30 ips
Image File Size	3-5 Kbyte (352x240), 5-10 Kbyte (704x240), 6-16 Kbyte (704x480)
Hard Disk Capacity	3 x HDD, No limit on HDD Size
Back-up Storage	USB Default (USB Memory Stick included) and/or backup to CD/DVD media via optional DVD writer
Alarm Inputs	16 Ch - 16 x TTL, programmable as NC/NO 8 Ch - 8 x TTL, programmable as NC/NO 4 Ch - 4 x TTL, programmable as NC/NO
Alarm Outputs	16 Ch - 16 x TTL 8 Ch - 8 x TTL 4 Ch - 1 NC/NO
Back-up File Formats	AVI, JPG, BMP
Ethernet Interface	10/100 Base-TX, RJ-45 connection
Network Control	Live View, Recording, Set-up, Playback, Search, Archiving
PTZ Control	via RS-485 Interface
PTZ Operation	Pan, Tilt, Zoom, Focus, Iris, Preset and Tour
Daylight Savings	Included
Time Sync	Automatic via NTP
Software Updates	via USB memory stick
Security	Multi-Level access control via user password
Remote Alarm Notification	via SMTP email
Supply Voltage	8 /16 Ch - 100VAC - 240VAC, 60/50 Hz 4 Ch - DC12V/5A (adapter Supplied)
Operating Temperature	41° - 104° Fahrenheit
Dimensions	8/16 ch - 16.9" x 3.5" x 18.1" 4 ch - 14.2" x 2.8" x 15.3" (WxHxD)
Rack Mount Size	8/16 ch - 2U 4 ch - 1.5U (see accessories for optional rack mount kits)
Weight	8/16 ch - 16.1 lbs. 4 ch - 8.3 lbs.

MODELS

4 Channel

DR4N*	4 Ch DVR w/no hard drive
DR4N-250*	250 GB HDD
DR4N-500*	500 GB HDD
DR4N-750*	750 GB HDD
DR4N-1TB*	1 TB HDD
DR4N-1.5TB*	1.5 TB HDD

*Add suffix "D" for DVD writer option (e.g.: DR4ND-250)

8 Channel

DR8N*	8 Ch DVR w/no hard drive
DR8N-250*	250 GB HDD
DR8N-500*	500 GB HDD
DR8N-750*	750 GB HDD
DR8N-1TB*	1 TB HDD
DR8N-1.5TB*	1.5 TB HDD
DR8N-2.25TB*	2.25 TB HDD

*Add suffix "D" for DVD writer option (e.g.: DR8ND-250)

16 Channel

DR16N*	16 Ch DVR w/no hard drive
DR16N-250*	250 GB HDD
DR16N-500*	500 GB HDD
DR16N-750*	750 GB HDD
DR16N-1TB*	1 TB HDD
DR16N-1.5TB*	1.5 TB HDD
DR16N-2TB*	2 TB HDD
DR16N-2.25TB*	2.25 TB HDD
DR16N-3TB	3 TB HDD

*Add suffix "D" for DVD writer option (e.g.: DR16ND-250)

Accessories

DR4-RM1A	Optional 19" Rack Mount Kit for 4 channel models
DR-RM2	Optional 19" Rack Mount Kit for 8 and 16 channel models



CBC (AMERICA) Corp.

NEW YORK: 55 MALL DRIVE COMMACK, NY 11725 • TEL: 1 (800) 422-6707 • (631) 864-9700 • FAX: (631) 543-5426
CALIFORNIA: 20521 EARL STREET TORRANCE, CA 90503 • TEL: 1 (800) 888-0131 • (310) 793-1500 • FAX: (310) 793-1506
www.computarganz.com © 2008 CBC (AMERICA) Corp. All Rights Reserved. 05/08



Pro-Pak Kits

OUTDOOR HOUSINGS WITH PRE-INSTALLED CAMERAS

Specifications

Housing Specifications

HOUSING	DESCRIPTION
HEATER POWER SUPPLY	Requires 24VAC, 15 watt power input (HWB-2 or H-2 models only)
CAMERA POWER SUPPLY	Use only 24VAC cameras with HWB-2, H-2, HWB-3 models
MAXIMUM CAMERA AND LENS SIZE	2.68" (W) x 2.1" (H) x 7.75" (L) .88" (W) x .54" (H) x 1.97" (L) mm
CABLE ENTRY	Two liquid tight rear fittings accept cable diameters from 4.3mm to 11.9mm. Two bottom feed-through liquid tight fittings accept cable diameters from 4.8mm to 7.9mm
WINDOW	3mm (D, 12") thick UV stabilized polycarbonate
HOUSING MOUNTING	Four available 1/4-20 tapped holes. Only one set of two are required for mounting.
CAMERA MOUNTING	Removable camera bracket. Mounted with two screws.
CONSTRUCTION	Aluminum cover, aluminum base, aluminum mounting foot, polycarbonate faceplate, glass reinforced polycarbonate end caps, neoprene gasket, ethylene propylene seal, and all stainless steel hardware.
FINISH	Off white
DIMENSIONS	3.75" (Dia) x 10.9" (L) 96mm (Dia) x 277mm (L)
WEIGHT	3 lbs./1.4kg
INTERNAL TEMPERATURE (WITH HEATER)	At external temperatures of -40° F to +122° F (-40° C to +50° C)
SALT ATMOSPHERE	Maintains internal temperatures between -4° F and +131° F (-20° C and +55° C) with heater.
ENCLOSURE PROTECTION	MIL-STD-883C, method 509, procedure I.
SAFETY COMPLIANCE	Designed to NEMA-3R, IP55
ACCESSORIES	CE, UL, dUL Sunshield (SS-1): Provides protection from the direct rays of sun and promotes cooling to reduce internal housing temperatures in hot climates. Wall bracket (WB-1): Attached to the foot of the housing allows wires to be fed-through the mount and into the foot of the housing (wall bracket is included with HWB-1 and HWB-2). Ceiling 'J' bracket (JB-1): Allows housing to be mounted from ceiling and allows wires to be fed-through the mount and into the foot of the housing. Pole Mount Adapter (PMA-1): Includes bracket and stainless steel straps for mounting to poles from 2" to 1.5" in diameter. Call for custom lens and camera combinations.
CUSTOM PRO-PAK KITS	



OPTIONAL HOUSING

MODEL HWB-3
Includes heater and blower and accommodates camera/lens combinations up to 9" long.
Maximum camera and lens size 2.8" x 2.8" x 9.0" (W x H x L), call for details.

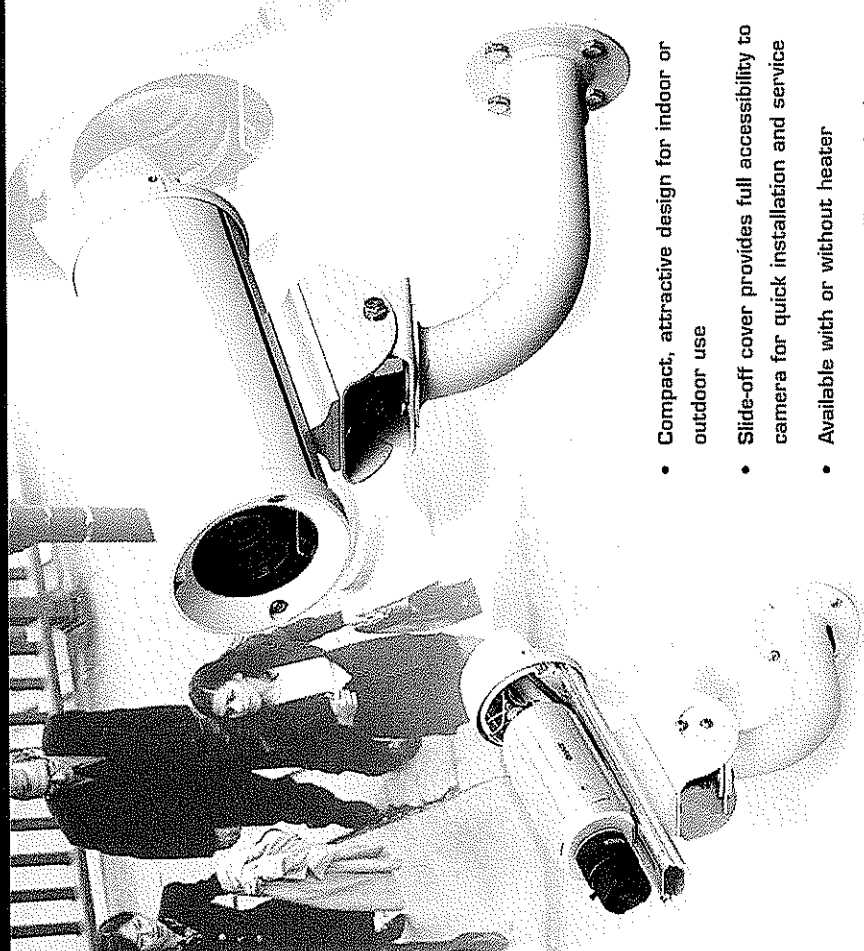

- Compact, attractive design for indoor or outdoor use
- Slide-off cover provides full accessibility to camera for quick installation and service
- Available with or without heater
- Optional sunshield, ceiling, and pole mount
- Rugged aluminum housing suitable for all weather conditions

Housings are pre-assembled with a variety of camera & lens options including Day/Night models



CBC (AMERICA) Corp.



NEW YORK: 55 MALL DRIVE COMMACK NY 11725 • TEL: 1 (800) 422-6707 • FAX: (631) 543-5428
CALIFORNIA: 2021 EARL STREET TORRANCE, CA 90503 • TEL: 1 (800) 898-0131 • (310) 793-1500 • FAX: (310) 793-1566
www.computercanz.com © 2008 CBC (AMERICA) Corp. All Rights Reserved. 5/08



CBC (AMERICA) Corp.

NY: 1-800-422-6707
CA: 1-800-888-0131
www.computercanz.com

housing features

Compact housing (only 1.1" long) accommodates all CANZ FC/YC/ZC/NH cameras with any Computer varifocal lens, including the 5-50mm

CBC's line of outdoor housings provide an attractive, compact solution for indoor or outdoor camera installations. The housing design incorporates a unique slide-off feature allowing full accessibility to the camera and lens even after installation. In addition, both wall and ceiling brackets offer feed-through wiring that fully conceals all cabling. The housings are available with an optional heater, and a sunshield is available for high temperature environments.

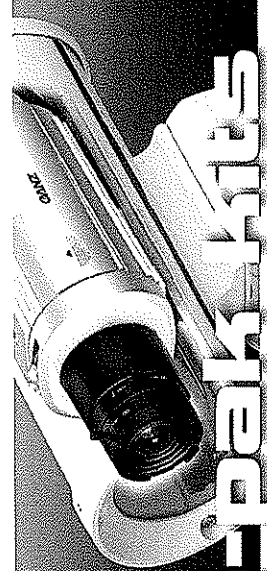
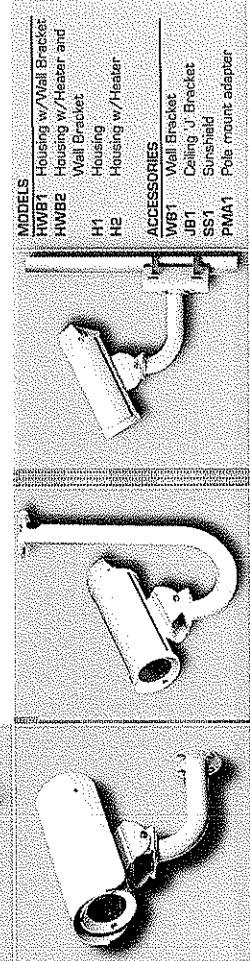
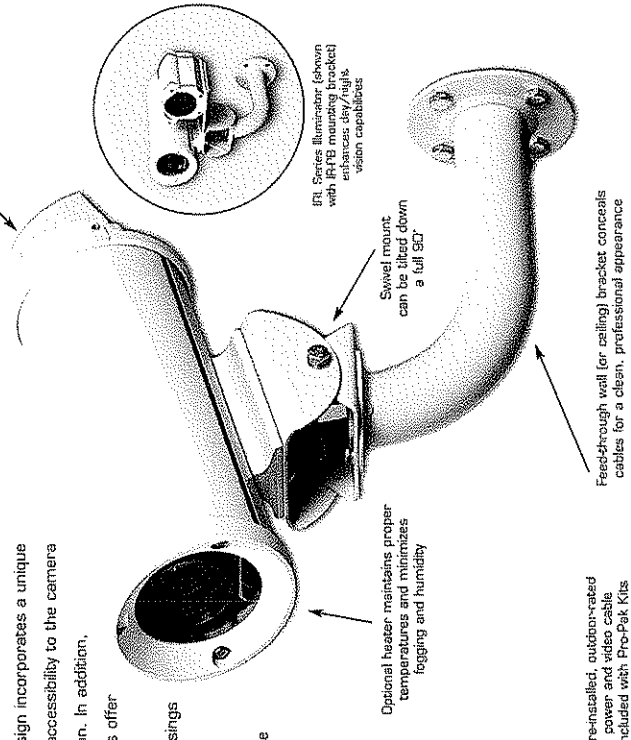

pro-pak kits

Housings with Pre-assembled Camera & Lens Packages
 Pro-Pak Kits can be ordered with a variety of Black & White, Color, and Day/Night cameras with manual or auto-iris varifocal lenses. All lenses are back-focused and each kit includes 5' of outdoor-rated power and video cable.

Day/Night Camera Options

YCH03A Color Digital Day/Night 540 TVL	ZC-NH405N Day/Night w/Mechanical Shutter 540 TVL	FC-65D/FC-62 BW/Hi-Res BW 380/570 TVL	YC-02C Color 350 TVL
--	--	---	----------------------------

Manual and Auto-Iris Lens Options

2.8-12mm 1/2" CS-MT F1.3	2.8-12mm 1/2" CS-MT F1.3	3.5-10.5mm 1/2" CS-MT F1.0	5-50mm 1/2" CS-MT F1.3
--------------------------------	--------------------------------	----------------------------------	------------------------------

Model Number Selection

Selecting the right Pro-Pak Kit for your application can be done in three easy steps. A single part number now provides you with the time-saving, installation-ready package of your choice.

Step 1: Choose your housing		Step 2: Choose your lens		Step 3: Choose your camera	
Model	Description	Model	Description	Model	Description
HWB1	Housing with Wall Bracket	29M	2.9-8.2mm F1.0 Manual Iris	2	FC-65D B/W 380 TVL
HWB2	Housing with Wall Bracket and Heater	29R	2.9-8.2mm F1.0 DC Auto Iris	3	FC-62 Hi-Res B/W 570 TVL
HJB1	Housing with Ceiling Bracket	29M	2.9-8.2mm F1.0 DC Auto Iris IR	5	YC-02C Color 330 TVL
HJB2	Housing with Ceiling Bracket and Heater	28M	2.8-12mm F1.3 Manual Iris	9	ZC-NH405N Super Hi-Res Color 540 TVL Day/Night Full-Featured Camera
		28R	2.8-12mm F1.3 DC Auto Iris IR	11	ZC-NH058N Super Hi-Res Color 540 TVL Day/Night Camera
		31M	3.5-10.5mm F1.0 Manual Iris	15	YCH-03A Super Hi-Res Color 540 TVL Digital Day/Night Camera
		31R	3.5-10.5mm F1.0 DC Auto Iris IR	Call for additional camera options	
		40R	8.5-40mm F1.3 DC Auto Iris IR		
		5R	5-50mm F1.3 Manual Iris		
		5R	5-50mm F1.3 DC Auto Iris		

Model Number Example: HWB2-29A 15

Housing with Wall Bracket and Heater, 2.9-8.2mm DC Auto Iris Lens with YCH-03A Hi-Res Color Camera



PS Series

24VAC INDOOR MASTER POWER SUPPLIES

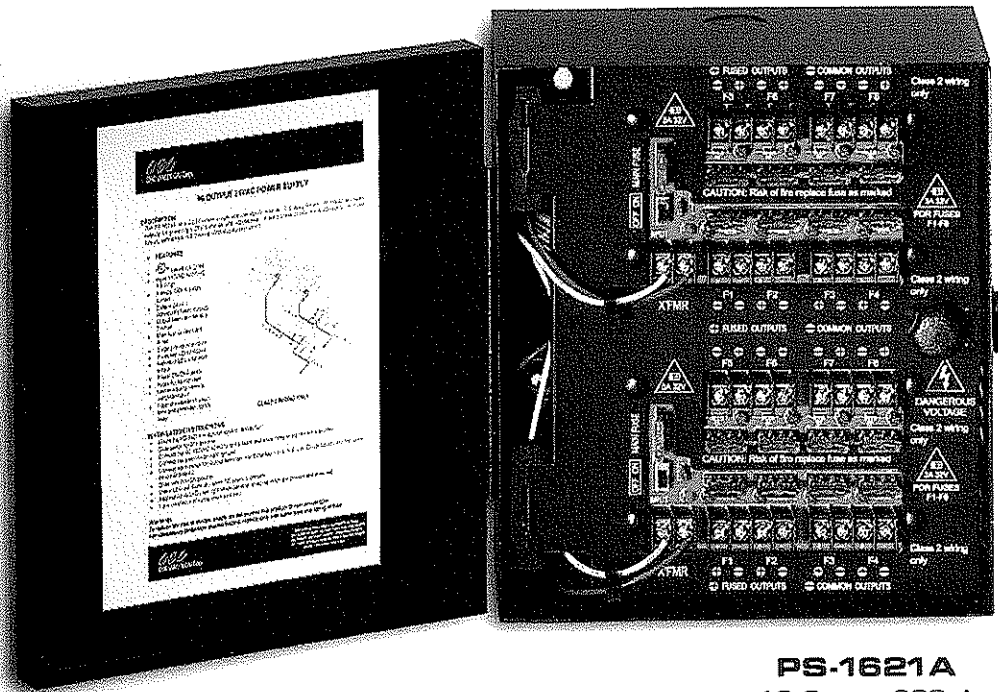

PS-1621A
16 Output 200va
Model Shown

FEATURES

PS Series power supplies offer an installer-friendly solution for powering 4-, 8-, or 16-camera CCTV systems. The power supplies have an input of 115 VAC. They are UL listed and housed in a metal enclosure.

- Outputs for 4, 8, or 16 Cameras (4-8 Amps supply current)
- Individually-fused 24VAC outputs
- Surge-protected outputs
- AC Power LED indicator with Power On/Off switch
- Units maintain camera synchronization
- Individual LEDs for each output
- Easy-to-find, automotive-style fuses
- Enclosure dimensions: 9.96" x 8.66" x 4.53" (HxWxD)

MODELS

PS-411A	4 Output	100 va
PS-811A	8 Output	100 va
PS-821A	8 Output	175 va
PS-1621A	16 Output	200 va

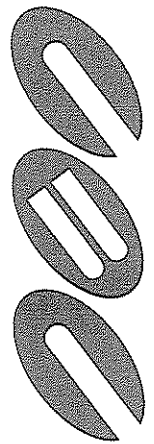

POWER SUPPLIES



CBC (AMERICA) Corp.

NEW YORK: 55 MALL DRIVE • COMMACK, NY 11725
 TEL: 1 (800) 422-6707 • (631) 864-9700 • FAX: (631) 543-5426
 CALIFORNIA: 20521 EARL STREET • TORRANCE, CA 90503
 TEL: 1 (800) 888-0131 • (310) 793-1500 • FAX: (310) 793-1506
 www.cbcamerica.com

Discover Series Mini-Domes

Features That Make a Difference:

- ▣ High impact vandal resistant housing that retains shape even after forceful impact
- ▣ Snap-on bubble liner for an extra level of covertness
- ▣ Advanced pivoting axis provides greater viewing flexibility
- ▣ Three quality auto iris lens options for better image quality and improved low light performance
- ▣ High impact vandal resistant polycarbonate bubbles (clear and tinted)
- ▣ Multiple camera options, including WDR model with latest Pixim® technology
- ▣ Night-Saver mode for extreme low light conditions
- ▣ Easy installation with eight mounting options (surface, flush, pendant, wall, wall-pole, wall-exterior corner, inside corner, electrical box)
- ▣ Discover drone option
- ▣ IP66 and NEMA4-rated¹ for -30° to 50°C (-22° to 122°F)

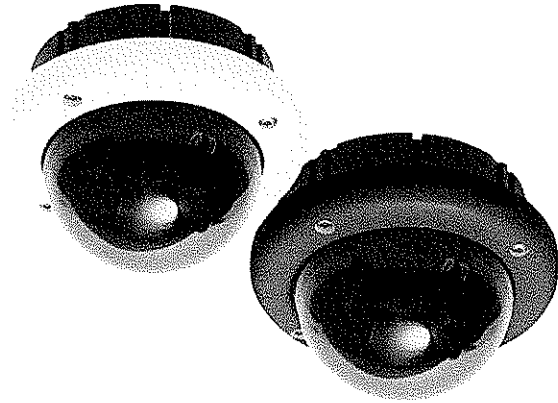

The Discover series of Mini-Domes delivers a vandal resistant camera solution at a non-vandal resistant price. This series of high performance mini-domes includes high impact, vandal resistant dome housings built to withstand even the harshest environments. Unlike other dome housings in the industry, which are made of metal, the Discover series housing is made with extremely durable composite and polycarbonate materials that have “shape memory”. The Discover housing comes with a choice of clear or tinted vandal resistant bubbles and includes a bubble liner to make it more covert. An advanced pivoting axis lets you position the camera at exactly the angle you need, while optimal white balance provides the clearest, most color-perfect images possible.

With three different types of mini-domes to choose from, there's a Discover solution just right for your particular requirements.

The Discover wide dynamic range (WDR) mini-dome uses over 504 lines of resolution and a pixel-by-pixel shutter speed that lets you see better in areas where both very bright and dark areas exist, such as an entranceway. This model also features up to a 2x digital zoom to get an even closer view of the action. Night-Saver mode improves performance in low light situations,

automatically switching from color to monochrome as light dims, and reverting back to color once light is restored. The WDR mini-dome also includes a DVR-Saver mode which helps conserve valuable hard drive space, reducing the size of video files by up to 30% when used with an Intellex® digital video management system.

The Discover high resolution mini-dome has 540 TVL and also includes a user-selectable Night-Saver mode. For challenging lighting environments, a selectable expanded auto white balance mode is available. Vivid colors and powerful low light performance provide some of the best images available on the market today.

The Discover standard resolution camera offers a cost effective solution for the value-conscious with 330 TVL. It is available with a 3.8 – 9.5 mm vari-focal, auto iris lens.

The Discover series includes a drone option—which looks like a mini-dome from the outside but without a camera inside—and is perfect for crime deterrence at an even greater cost savings.

⁽¹⁾ Self certified

Discover Mini-Dome Mounts

The Discover series of Mini-Domes includes eight mounting options that work with the vandal resistant cameras. Choose from surface, flush, pendant, wall, wall-pole, wall-exterior corner, inside corner, or electrical box-mounts. With eight mounting options, there is a mount to fit any installation situation. All the mounts are quick and easy to install. Installing the surface mount is easy and requires just four screws. Flush mounts have two automatic swing-out tabs that clamp onto the installation surface. An optional pendant cap provides a three-quarter inch thread for pendant mount installation while maintaining an environmental seal. The same pendant cap is available in an attractive wall mount configuration. A pole strap adapter is also available for the wall mount arm. A corner bracket adapter is available for wall-pole and inside corner mounting applications such as when needed for mounting inside an elevator. All of the eight mounts are available in black and white finishes.

Mounts & Accessories for Discover Mini-Domes

White	Black	
ADCDMWALL	ADCBMWALL	Wall mount w/pendant cap
ADCDMCRNRO	ADCBMCRNRO	Outside corner adapter for use with ADCDMWALL or ADCBMWALL
ADCDMPEND	ADCBMPEND	Pendant cap, three-quarter inch thread
ADCDMCRNR	ADCBMCRNR	Corner mount
ADCDMPOLE	ADCBMPOLE	Pole mount for use with ADCDMWALL or ADCBMWALL
ADCDMELEC	ADCBMELEC	4S electrical box adapter
ADCDSLG (color independent)		Video service lead cable
ADCDDRONE	ADCBDRONE	Drone, no camera or lens capability

Wall Mount with Pendant Cap (ADCDMWALL)

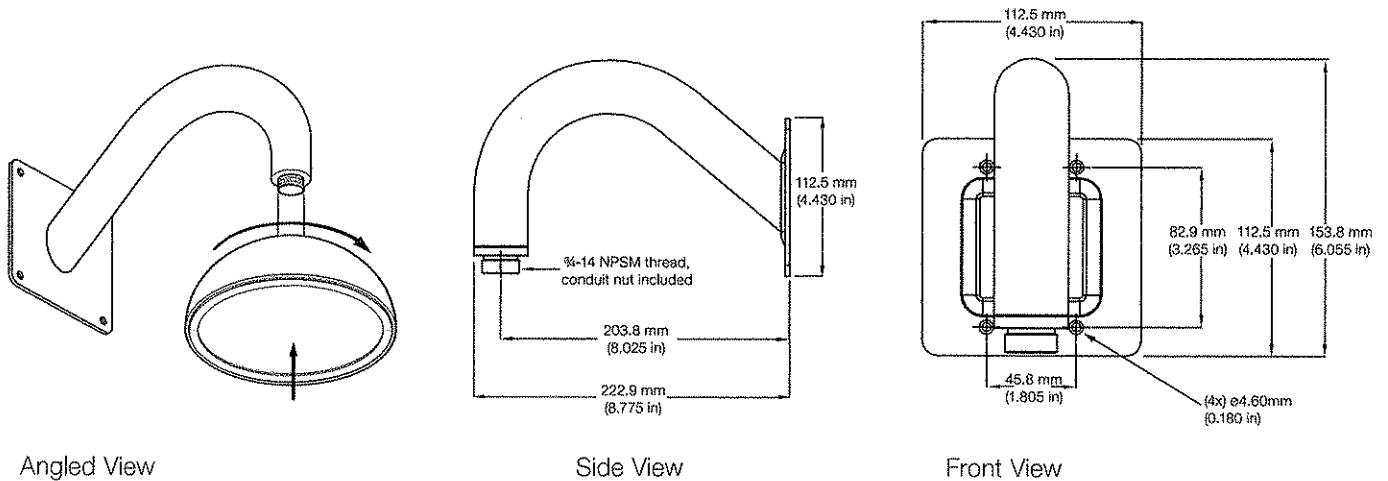

Pendant Cap with Three-Quarter Thread (ADCDMPEND)

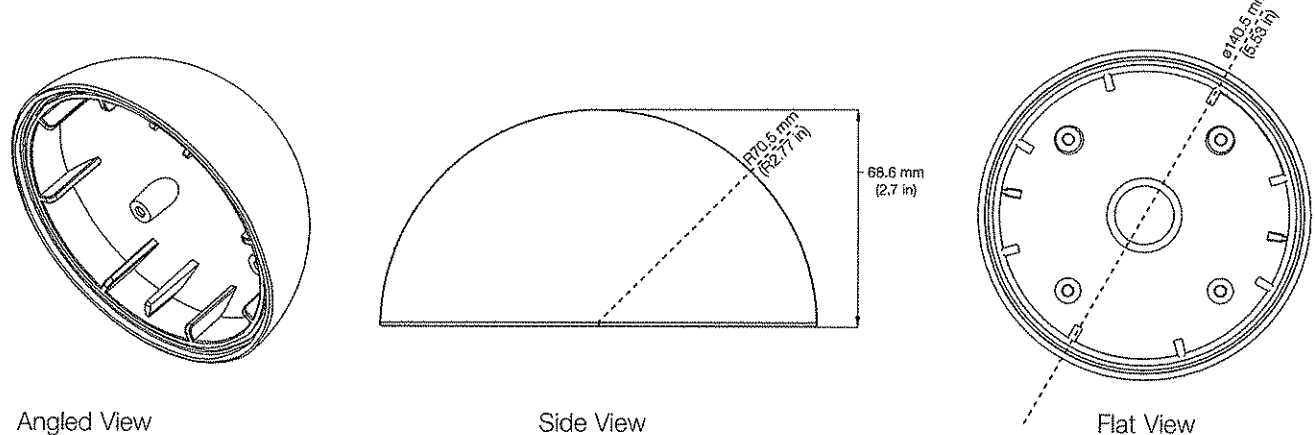

4S Electrical Box Adapter (ADCDMELEC)

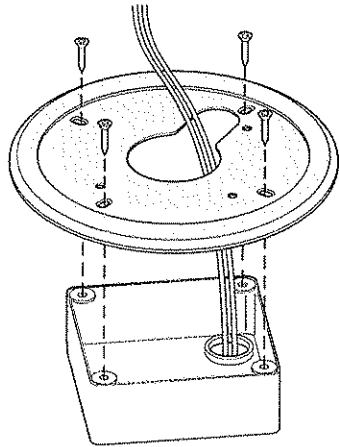

In Use

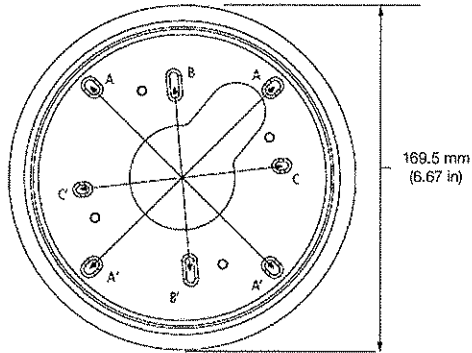

A. $\theta=0.59$ cm (0.23 in), A-A=12.20 cm (4.80 in)
 B. $\theta=0.36$ cm (0.14 in), B-B=9.60 cm (3.78 in)
 C. $\theta=0.53$ cm (0.21 in), C-C=8.42 cm (3.32 in)

Flat View

Pole Mount Adapter (ADCDMPOLE)

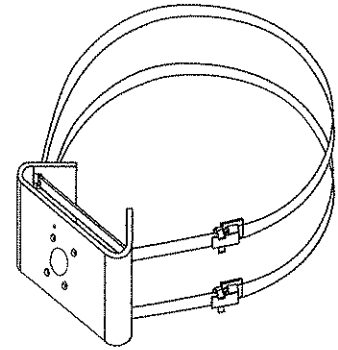

Angled View

Inside Corner Mount (ADCDMCRNR)

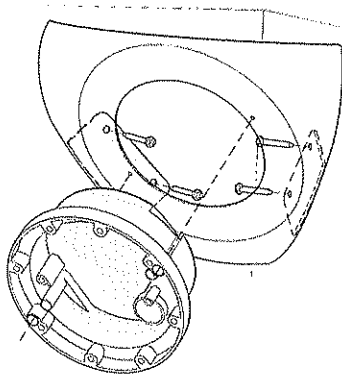

Angled View

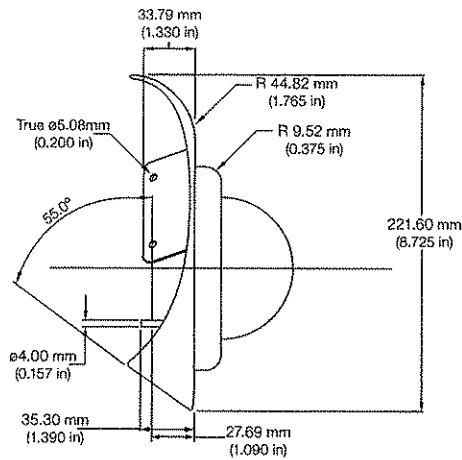

Side View

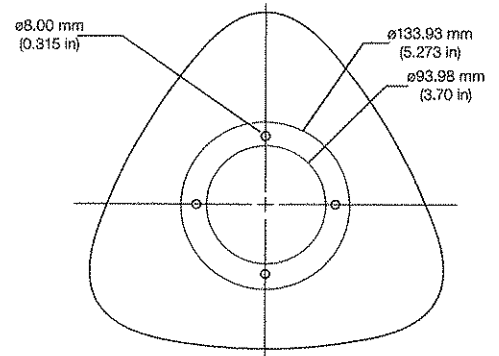

Flat View

Outside Corner Mount (ADCDMCRNRO)

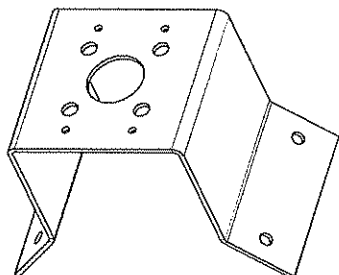

Angled View

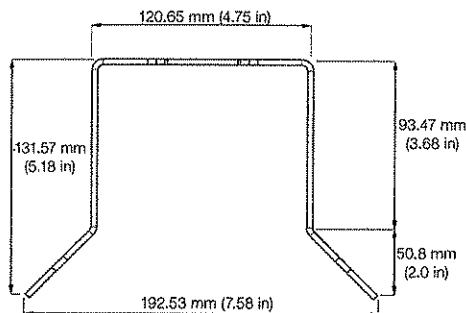

Side View

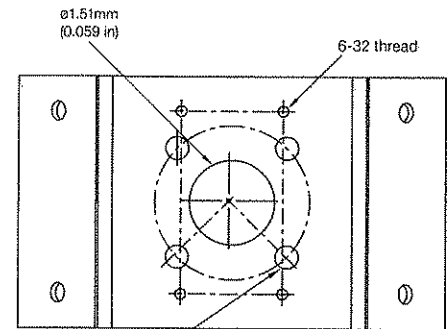

Flat View

	Wide Dynamic Range	High Resolution	Standard Resolution
General			
Imager	Pixim orca sensor	1/3-inch CCD	1/3-inch CCD
Video Output	1.0 Vp-p/75-ohm, BNC	1.0 Vp-p/75-ohm, BNC	1.0 Vp-p/75-ohm, BNC
Horizontal Resolution	504+ TV lines	540 TV lines	330 TV lines
Active Pixel Count (H x V)	Universal: 720 x 540	NTSC: 768 x 494 (PAL: 752 x 582)	NTSC: 510 x 492 (PAL: 500 x 582)
Minimum Scene Illumination	0.95 lux @ F1.2	0.65 lux @ F1.2	0.7 lux @ F1.2
Digital Slow Shutter (DSS)	2x (default) – 32x	N/A	N/A
Wide Dynamic Range	120 dB/17-bit	N/A	N/A
Sync System	Line-lock, phase-adjustable or internal	Line-lock, adjustable or internal	Internal
S/N Ratio	>42 dB	50 dB	48 dB
White Balance	Automatic white balance (AWB), One-touch & manual	AWB	AWB
AWB Ranges—Normal (Extended)	2200 – 7500 K (2000 K-11000 K)	2700 – 11000 K (2000 – 18000 K)	2700 – 11000 K (N/A)
WDR Metering Zone	One zone adjustable	N/A	N/A
Backlight Compensation	N/A	Center weighted on/off	N/A
Flickerless Mode	Selectable on/off	Selectable on/off	N/A
Night-Saver	Selectable on/off	Selectable on/off	N/A
DVR-Saver Mode	Selectable on/off	N/A	N/A
Digital Zoom	Scalable, up to 2x	N/A	N/A
Power Consumption	3 watts	2.8 watts	1.7 watts
Weight	0.9 kg (1.9 lbs)	1.0 kg (2.2 lbs)	0.9 kg (1.9 lbs)

Common to all Discover Mini-Domes

Physical, Electrical, Environmental & Regulatory		Lenses	
Dimensions (H x W)	92 x 136 mm (3.6 x 5.4 in)	2.5 – 6 mm auto iris lens	
Housing Color	White or Black	F-Stop	F1.3 – 360
Environmental Rating	IP66 ¹ , NEMA4 ¹	Field of View (H x V)	108.2° x 80.4° (wide) & 47.6° x 35.6° (tele)
Bubble Diameter	94 mm (3.7 in)	3.8 – 9.5 mm auto iris lens	
Bubble Thickness	2.5 mm (0.1 in)	F-Stop	F1.2 – 360
Bubble F-Stop	F1.0 (tinted); F0 (clear)	Field of View (H x V)	74.2° x 54.0° (wide) & 30.0° x 22.4° (tele)
Pan & Effective Tilt (at 17 in) Range ²	360° & 180° (+/-90°)	9 – 22 mm auto iris lens	
Power Input ³	12 VDC -10% +20% 24 VAC +/-20%, 50/60 Hz	F-Stop	F1.8 – 360
Power Connection	Flying lead or plug	Field of View (H x V)	30.7° x 22.7° (wide) & 14.1° x 10.6° (tele)
Operating Temperature	-30° to 50°C (-22° to 122°F)		
Humidity	90% (noncondensing)		
Storage Temperature	-20° to 60°C (-4° to 140°F)		
Emissions	FCC part 15 Class B CE: EN55022 ICES-003		
Immunity	CE: EN50130-4		
Safety	UL/cUL, CSA C22.2		

(1) Self certified

(2) Using a 2.5-6 mm lens at wide angle

(3) NEC Class 2/LPS power supply required

BRAND	FINISH	CAMERA	LENS	BUBBLE	FORMAT
AD	XX	X	XXXX	X	X
AD	CD = White CB = Black	H = High resolution W = Wide dynamic range S = Standard resolution	2506 = 2.5 – 6 mm 3895 = 3.8 – 9.5 mm 0922 = 9 – 22 mm	C = Clear T = Tinted	N = NTSC P = PAL U = Universal

Product offerings and specifications are subject to change without notice. Actual products may vary from photos. Not all products include all features. Availability varies by region; contact your sales representative. Certain product names mentioned herein may be trade names and/or registered trademarks of other companies.

© 2009 Tyco International Ltd. and its respective companies. All rights reserved. AD0001-DS-200901-R05-LT-EN

www.americandynamics.net



tyco



APC BACK-UPS 1200VA 120V

Part Number: BR1200

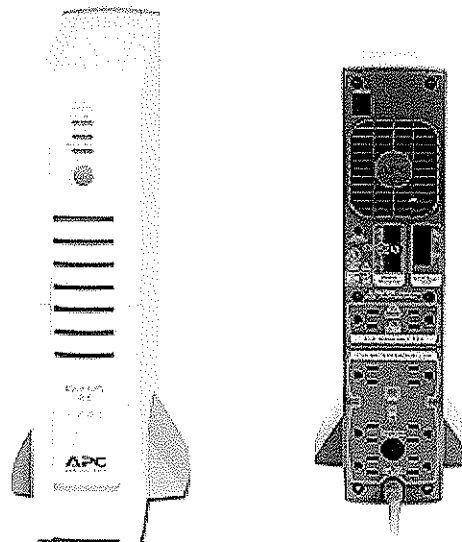

Output

- Output Power Capacity 780 Watts / 1200 VA
- Max Configurable Power 780 Watts / 1200 VA
- Nominal Output Voltage 120V
- Output Connections (2) NEMA 5-15R (Surge Protection)
- (6) NEMA 5-15R (Battery Backup)



Input

- Nominal Input Voltage 120V
- Input Frequency 47 - 63 Hz
- Input Connections NEMA 5-15P



- Cord Length 6 feet (1.83 meters)
- Input voltage range for main operations 88 - 148V
- Input voltage adjustable range 78 - 152V

for mains operation

Batteries & Runtime

Battery Type	Maintenance-free sealed Lead-Acid battery with suspended electrolyte : leakproof
Included Battery Modules	1
Typical recharge time	15 hour(s)
Replacement Battery	<u>RBC32</u>
RBC™ Quantity	1
Typical Backup Time at Half Load	17.4 minutes (390 Watts)
Typical Backup Time at Full Load	6.2 minutes (780 Watts)
Runtime Chart	<u>Back-UPS RS</u>

Communications & Management

Interface Port(s)	USB
Control panel	LED status display with On Line : On Battery : Replace Battery and Overload indicators
Audible Alarm	Alarm when on battery : distinctive low battery alarm : configurable delays

Surge Protection and Filtering

Surge energy rating	420 Joules
Filtering	Full time multi-pole noise filtering : 5% IEEE surge let-through : zero clamping response time : meets UL 1449
Data Line Protection	RJ-45 Modem/Fax protection (two wire single line),RJ45 10/100 Base-T Ethernet protection

Physical

Maximum Height	14.60 inches (371 mm)
Maximum Width	3.40 inches (86 mm)
Maximum Depth	13.10 inches (333 mm)

Rack Height	2U
Net Weight	22.00 lbs. (10.00 kg)
Shipping Weight	23.00 lbs. (10.45 kg)
Shipping Height	17.90 inches (455 mm)
Shipping Width	8.00 inches (203 mm)
Shipping Depth	16.38 inches (416 mm)
Color	Beige
SCC Codes	1073130422627 4
Units per Pallet	36.00

Environmental

Operating Environment	32 - 104 °F (0 - 40 °C)
Operating Relative Humidity	0%
Operating Elevation	0-10000 feet (0-3000 meters)
Storage Temperature	23 - 113 °F (-5 - 45 °C)
Storage Relative Humidity	0%
Storage Elevation	0-50000 feet (0-15000 meters)
Audible noise at 1 meter from surface of unit	45.00 dBA
Online Thermal Dissipation	180.00 BTU/hr

Conformance

Regulatory Approvals	cUL Listed,FCC Part 15 Class B,FCC Part 68,UL 1449,UL 1778,UL Listed
Standard Warranty	3 years repair or replace
Equipment protection policy	Lifetime : \$150000

*Except where noted, all prices are Estimated Resale Price (ERP) - Without Tax/VAT. Pricing in other locations and sites may vary.

**The time to recharge to 90% of full battery capacity following a discharge to shutdown using a load rated for 1/2 the full load rating of the UPS.

Copyright © American Power Conversion Corp., all rights reserved