



State of West Virginia  
 Department of Administration  
 Purchasing Division  
 2019 Washington Street East  
 Post Office Box 50130  
 Charleston, WV 25305-0130

# Request for Quotation

RFQ NUMBER  
**PRS09021**

PAGE  
**1**

ADDRESS CORRESPONDENCE TO ATTENTION OF  
**JOHN ABBOTT  
 304-558-2544**

**VENDOR**  
 \*709045245      304-744-0590  
**GARCIE R MARKER & SONS INC**  
**1119 JEFFERSON ROAD**  
  
**SOUTH CHARLESTON WV 25309**

**SHIP TO**  
**PROTECTIVE SERVICES**  
**DIVISION OF**  
**BUILDING 1, ROOM 152-A**  
**1900 KANAWHA BOULEVARD, EAST**  
**CHARLESTON, WV**  
**25305                                  304-558-9911**

DATE PRINTED	TERMS OF SALE	SHIP VIA	F.O.B.	FREIGHT TERMS
01/13/2009				

BID OPENING DATE: **02/17/2009**      BID OPENING TIME **01:30PM**

LINE	QUANTITY	UOP	CAT NO.	ITEM NUMBER	UNIT PRICE	AMOUNT
0001	1	LS		550-43	TOTAL	\$394,263.00
<b>BOLLARD SYSTEM INSTALLATION</b>  <b>CONTRACT TO PROVIDE PROTECTIVE BOLLARD SYSTEMS IN DESIGNATED LOCATIONS AT THE WEST VIRGINIA STATE CAPITOL COMPLEX, PER THE SPECIFICATIONS.</b>  <b>MANDATORY PRE-BID: STATE OF WV DIVISION OF PURCHASING 2019 WASHINGTON STREET, EAST CHARLESTON, WV 25305 JANUARY 27, 2009; 11:00 AM.</b>  <b>QUESTIONS: QUESTIONS SHALL BE SUBMITTED TO JOHN ABBOTT NO LATER THAN 1/23/2009; 1:00 PM PREFERENCE: JOHN.H.ABBOTT@WV.GOV FAX: 304-558-4115</b>  <b>EXHIBIT 5</b>  <b>WEST VIRGINIA CODE 21-1D-5 PROVIDES THAT: ANY SOLICITATION FOR A PUBLIC IMPROVEMENT CONSTRUCTION CONTRACT REQUIRES EACH VENDOR THAT SUBMITS A BID FOR THE WORK TO SUBMIT AT THE SAME TIME AN AFFIDAVIT OF COMPLIANCE WITH THE BID. THE ENCLOSED PURCHASING AFFIDAVIT MUST BE SIGNED AND SUBMITTED WITH THE BID AS EVIDENCE OF THE VENDOR'S COMPLIANCE WITH THE PROVISIONS OF ARTICLE 1D, CHAPTER 21 OF THE WEST VIRGINIA CODE. FAILURE TO SUBMIT THE SIGNED PURCHASING AFFIDAVIT WITH THE BID SHALL RESULT IN DISQUALIFICATION OF SUCH BID.</b>						

**RECEIVED**  
**2009 FEB 25 A 8:27**  
**PURCHASING DIVISION**  
**STATE OF WV**

SEE REVERSE SIDE FOR TERMS AND CONDITIONS

SIGNATURE <i>Allen Marker</i>	TELEPHONE 304-744-0590	DATE 02/25/09
TITLE President	FEIN 55-058-0625	ADDRESS CHANGES TO BE NOTED ABOVE

WHEN RESPONDING TO RFQ, INSERT NAME AND ADDRESS IN SPACE ABOVE LABELED 'VENDOR'

**GENERAL TERMS & CONDITIONS**  
**REQUEST FOR QUOTATION (RFQ) AND REQUEST FOR PROPOSAL (RFP)**

1. Awards will be made in the best interest of the State of West Virginia.
2. The State may accept or reject in part, or in whole, any bid.
3. All quotations are governed by the *West Virginia Code* and the *Legislative Rules* of the Purchasing Division.
4. Prior to any award, the apparent successful vendor must be properly registered with the Purchasing Division and have paid the required \$125 fee.
5. All services performed or goods delivered under State Purchase Order/Contracts are to be continued for the term of the Purchase Order/Contracts, contingent upon funds being appropriated by the Legislature or otherwise being made available. In the event funds are not appropriated or otherwise available for these services or goods, this Purchase Order/Contract becomes void and of no effect after June 30.
6. Payment may only be made after the delivery and acceptance of goods or services.
7. Interest may be paid for late payment in accordance with the *West Virginia Code*.
8. Vendor preference will be granted upon written request in accordance with the *West Virginia Code*.
9. The State of West Virginia is exempt from federal and state taxes and will not pay or reimburse such taxes.
10. The Director of Purchasing may cancel any Purchase Order/Contract upon 30 days written notice to the seller.
11. The laws of the State of West Virginia and the *Legislative Rules* of the Purchasing Division shall govern all rights and duties under the Contract, including without limitation the validity of this Purchase Order/Contract.
12. Any reference to automatic renewal is hereby deleted. The Contract may be renewed only upon mutual written agreement of the parties.
13. **BANKRUPTCY:** In the event the vendor/contractor files for bankruptcy protection, this Contract may be deemed null and void, and terminated without further order.
14. **HIPAA BUSINESS ASSOCIATE ADDENDUM:** The West Virginia State Government HIPAA Business Associate Addendum (BAA), approved by the Attorney General, and available online at the Purchasing Division's web site (<http://www.state.wv.us/admin/purchase/vrc/hipaa.htm>) is hereby made part of the agreement. Provided that, the Agency meets the definition of a Cover Entity (45 CFR §160.103) and will be disclosing Protected Health Information (45 CFR §160.103) to the vendor.
15. **WEST VIRGINIA ALCOHOL & DRUG-FREE WORKPLACE ACT:** If this Contract constitutes a public improvement construction contract as set forth in Article 1D, Chapter 21 of the West Virginia Code ("The West Virginia Alcohol and Drug-Free Workplace Act"), then the following language shall hereby become part of this Contract: "The contractor and its subcontractors shall implement and maintain a written drug-free workplace policy in compliance with the West Virginia Alcohol and Drug-Free Workplace Act, as set forth in Article 1D, Chapter 21 of the West Virginia Code. The contractor and its subcontractors shall provide a sworn statement in writing, under the penalties of perjury, that they maintain a valid drug-free work place policy in compliance with the West Virginia and Drug-Free Workplace Act. It is understood and agreed that this Contract shall be cancelled by the awarding authority if the Contractor: 1) Fails to implement its drug-free workplace policy; 2) Fails to provide information regarding implementation of the contractor's drug-free workplace policy at the request of the public authority; or 3) Provides to the public authority false information regarding the contractor's drug-free workplace policy."

---

**INSTRUCTIONS TO BIDDERS**

1. Use the quotation forms provided by the Purchasing Division.
2. **SPECIFICATIONS:** Items offered must be in compliance with the specifications. Any deviation from the specifications must be clearly indicated by the bidder. Alternates offered by the bidder as **EQUAL** to the specifications must be clearly defined. A bidder offering an alternate should attach complete specifications and literature to the bid. The Purchasing Division may waive minor deviations to specifications.
3. Complete all sections of the quotation form.
4. Unit prices shall prevail in case of discrepancy.
5. All quotations are considered F.O.B. destination unless alternate shipping terms are clearly identified in the quotation.
6. **BID SUBMISSION:** All quotations must be delivered by the bidder to the office listed below prior to the date and time of the bid opening. Failure of the bidder to deliver the quotations on time will result in bid disqualifications: Department of Administration, Purchasing Division, 2019 Washington Street East, P.O. Box 50130, Charleston, WV 25305-0130



State of West Virginia  
 Department of Administration  
 Purchasing Division  
 2019 Washington Street East  
 Post Office Box 50130  
 Charleston, WV 25305-0130

# Request for Quotation

RFQ NUMBER  
**PRS09021**

PAGE  
**2**

ADDRESS CORRESPONDENCE TO ATTENTION OF  
**JOHN ABBOTT**  
**304-558-2544**

**VENDOR**  
 \*709045245      304-744-0590  
**GARCIE R MARKER & SONS INC**  
**1119 JEFFERSON ROAD**  
**SOUTH CHARLESTON WV 25309**

**SHIP TO**  
**PROTECTIVE SERVICES**  
**DIVISION OF**  
**BUILDING 1, ROOM 152-A**  
**1900 KANAWHA BOULEVARD, EAST**  
**CHARLESTON, WV**  
**25305      304-558-9911**

DATE PRINTED <b>01/13/2009</b>	TERMS OF SALE	SHIP VIA	F.O.B.	FREIGHT TERMS
-----------------------------------	---------------	----------	--------	---------------

BID OPENING DATE: **02/17/2009**      BID OPENING TIME **01:30PM**

LINE	QUANTITY	UOP	CAT NO	ITEM NUMBER	UNIT PRICE	AMOUNT
<p><b>NOTICE TO PROCEED: THIS CONTRACT IS TO BE PERFORMED WITHIN 60 CALENDAR DAYS AFTER THE NOTICE TO PROCEED IS RECEIVED. UNLESS OTHERWISE SPECIFIED, THE FULLY EXECUTED PURCHASE ORDER WILL BE CONSIDERED NOTICE TO PROCEED.</b></p> <p><b>CANCELLATION: THE DIRECTOR OF PURCHASING RESERVES THE RIGHT TO CANCEL THIS CONTRACT IMMEDIATELY UPON WRITTEN NOTICE TO THE VENDOR IF THE MATERIALS OR WORKMANSHIP SUPPLIED ARE OF AN INFERIOR QUALITY OR DO NOT CONFORM WITH THE SPECIFICATIONS OF THE BID AND CONTRACT HERE IN.</b></p> <p><b>WAGE RATES: THE CONTRACTOR OR SUBCONTRACTOR SHALL PAY THE HIGHER OF THE U.S. DEPARTMENT OF LABOR MINIMUM WAGE RATES AS ESTABLISHED FOR KANAWHA COUNTY, PURSUANT TO WEST VIRGINIA CODE 21-5A, ET, SEQ. (PREVAILING WAGE RATES APPLY TO THIS PROJECT)</b></p> <p><b>ARBITRATION: ANY REFERENCES MADE TO ARBITRATION OR INTEREST FOR PAYMENTS DUE (EXCEPT FOR ANY INTEREST REQUIRED BY STATE LAW) CONTAINED IN THIS CONTRACT OR IN ANY AMERICAN INSTITUTE OF ARCHITECTS DOCUMENTS PERTAINING TO THIS CONTRACT ARE HEREBY DELETED.</b></p> <p><b>WORKERS' COMPENSATION: VENDOR IS REQUIRED TO PROVIDE A CERTIFICATE FROM WORKERS' COMPENSATION IF SUCCESSFUL.</b></p> <p><b>ALL OF THE ITEMS CHECKED BELOW WILL BE A REQUIREMENT OF THIS CONTRACT:</b></p> <p><b>(XX) INSURANCE: SUCCESSFUL VENDOR SHALL FURNISH PROOF OF COMMERCIAL GENERAL LIABILITY INSURANCE PRIOR TO ISSUANCE OF CONTRACT. UNLESS OTHERWISE SPECIFIED IN THE BID DOCUMENTS, THE MINIMUM AMOUNT OF INSURANCE</b></p>						

SEE REVERSE SIDE FOR TERMS AND CONDITIONS

SIGNATURE	TELEPHONE	DATE
-----------	-----------	------

TITLE	FEIN	ADDRESS CHANGES TO BE NOTED ABOVE
-------	------	-----------------------------------

WHEN RESPONDING TO RFQ, INSERT NAME AND ADDRESS IN SPACE ABOVE LABELED 'VENDOR'



State of West Virginia  
 Department of Administration  
 Purchasing Division  
 2019 Washington Street East  
 Post Office Box 50130  
 Charleston, WV 25305-0130

# Request for Quotation

RFQ NUMBER  
**PRS09021**

PAGE  
**3**

ADDRESS CORRESPONDENCE TO ATTENTION OF  
**JOHN ABBOTT**  
**304-558-2544**

VENDOR

\*709045245      304-744-0590  
**GARCIE R MARKER & SONS INC**  
**1119 JEFFERSON ROAD**  
  
**SOUTH CHARLESTON WV 25309**

SHIP TO

**PROTECTIVE SERVICES**  
**DIVISION OF**  
**BUILDING 1, ROOM 152-A**  
**1900 KANAWHA BOULEVARD, EAST**  
**CHARLESTON, WV**  
**25305                      304-558-9911**

DATE PRINTED	TERMS OF SALE	SHIP VIA	F.O.B.	FREIGHT TERMS
01/13/2009				

BID OPENING DATE: **02/17/2009**      BID OPENING TIME **01:30PM**

LINE	QUANTITY	UOP	CAT NO	ITEM NUMBER	UNIT PRICE	AMOUNT
<p>COVERAGE REQUIRED IS \$250,000.</p> <p>( ) BUILDERS RISK INSURANCE: SUCCESSFUL VENDOR SHALL FURNISH PROOF OF BUILDERS RISK - ALL RISK INSURANCE IN AN AMOUNT EQUAL TO 100% OF THE AMOUNT OF THE CONTRACT.</p> <p>(XX) BONDS: FIVE PERCENT (5%) OF THE TOTAL AMOUNT OF THE BID PAYABLE TO THE STATE OF WEST VIRGINIA, SHALL BE SUBMITTED WITH EACH BID AS A BID BOND. THE SUCCESSFUL BIDDER SHALL ALSO FURNISH A PERFORMANCE BOND AND LABOR/MATERIAL BOND FOR 100% OF THE AMOUNT OF THE CONTRACT. BONDS MAY BE PROVIDED IN THE FORM OF A CERTIFIED CHECK IRREVOCABLE LETTER OF CREDIT, OR BOND FURNISHED BY A SOLVENT SURETY COMPANY AUTHORIZED TO DO BUSINESS IN THE STATE OF WEST VIRGINIA. A LETTER OF CREDIT SUBMITTED IN LIEU OF A BOND WILL ONLY BE ALLOWED FOR PROJECTS UNDER \$100,000. PERSONAL OR BUSINESS CHECKS ARE NOT ACCEPCTABLE IN LIEU OF THE 5% BID BOND, PERFORMANCE BOND, OR LABOR AND MATERIAL BOND.</p> <p>( ) MAINTENANCE BOND: A TWO (2) YEAR MAINTENANCE BOND COVERING THE ROOFING SYSTEM WILL BE A REQUIREMENT OF THE SUCCESSFUL VENDOR.</p> <p>REV. 11/00</p> <p>EXHIBIT 7</p> <p>DOMESTIC ALUMINUM, GLASS &amp; STEEL IN PUBLIC WORKS PROJECTS</p> <p>IN ACCORDANCE WITH WEST VIRGINIA CODE 5-19-1 ET., SEQ., EVERY CONTRACT FOR CONSTRUCTION, RECONSTRUCTION, ALTERATION, REPAIR, IMPROVEMENT OR MAINTENANCE OF PUBLIC WORKS, WHERE THE COST IS MORE THAN \$50,000 AND,</p>						

SEE REVERSE SIDE FOR TERMS AND CONDITIONS

SIGNATURE	TELEPHONE	DATE
TITLE	FEIN	ADDRESS CHANGES TO BE NOTED ABOVE

WHEN RESPONDING TO RFQ, INSERT NAME AND ADDRESS IN SPACE ABOVE LABELED 'VENDOR'



State of West Virginia  
 Department of Administration  
 Purchasing Division  
 2019 Washington Street East  
 Post Office Box 50130  
 Charleston, WV 25305-0130

# Request for Quotation

RFQ NUMBER  
**PRS09021**

PAGE  
**4**

ADDRESS CORRESPONDENCE TO ATTENTION OF:  
**JOHN ABBOTT**  
**304-558-2544**

VENDOR

\*709045245      304-744-0590  
**GARCIE R MARKER & SONS INC**  
**1119 JEFFERSON ROAD**  
**SOUTH CHARLESTON WV 25309**

SHIP TO

**PROTECTIVE SERVICES**  
**DIVISION OF**  
**BUILDING 1, ROOM 152-A**  
**1900 KANAWHA BOULEVARD, EAST**  
**CHARLESTON, WV**  
**25305      304-558-9911**

DATE PRINTED	TERMS OF SALE	SHIP VIA	FOB	FREIGHT TERMS
01/13/2009				

BID OPENING DATE: **02/17/2009**      BID OPENING TIME **01:30PM**

LINE	QUANTITY	UOP	CAT NO	ITEM NUMBER	UNIT PRICE	AMOUNT
<p>IN THE CASE OF STEEL ONLY, WHERE THE COST OF STEEL IS MORE THAN \$50,000 OR WHERE MORE THAN 10,000 POUNDS OF STEEL ARE REQUIRED, THE STATE WILL ACCEPT ONLY ALUMINUM GLASS, OR STEEL PRODUCTS PRODUCED IN THE UNITED STATES. IN ADDITION, ITEMS OF MACHINERY OR EQUIPMENT PURCHASED FOR USE AT THE SITE OF PUBLIC WORKS SHALL BE MADE OF DOMESTIC ALUMINUM, GLASS OR STEEL, UNLESS THE COST OF THE PRODUCT IS LESS THAN \$50,000 OR LESS THAN 10,000 POUNDS OF STEEL ARE USED IN PUBLIC WORKS PROJECTS.</p> <p>FOREIGN MADE ALUMINUM, GLASS OR STEEL PRODUCTS MAY BE ACCEPTED ONLY IF THE COST OF DOMESTIC PRODUCTS IS FOUND TO BE UNREASONABLE. SUCH COST IS UNREASONABLE IF IT IS 20% OR MORE HIGHER THAN THE BID PRICE FOR FOREIGN MADE PRODUCTS. IF THE DOMESTIC ALUMINUM, GLASS OR STEEL PRODUCTS TO BE SUPPLIED OR PRODUCED IN A "SUBSTANTIAL LABOR SURPLUS AREA", AS DEFINED BY THE UNITED STATES DEPARTMENT OF LABOR, FOREIGN PRODUCTS MAY BE SUPPLIED ONLY IF DOMESTIC PRODUCTS ARE 30% OR MORE HIGHER IN PRICE THAN THE FOREIGN MADE PRODUCTS.</p> <p>IF, PRIOR TO THE AWARD OF A CONTRACT UNDER THE ABOVE PROVISIONS, THE SPENDING OFFICER OF THE SPENDING UNIT DETERMINES THAT THERE EXISTS A BID FOR LIKE FOREIGN ALUMINUM, GLASS OR STEEL THAT IS REASONABLE AND LOWER THAN THE LOWEST BID DOMESTIC PRODUCTS, THE SPENDING OFFICE MAY REQUEST, IN WRITING, A REEVALUATION AND REDUCTION IN THE LOWEST BID FOR SUCH DOMESTIC PRODUCTS. ALL VENDORS MUST INDICATE IN THEIR BID IF THEY ARE SUPPLYING FOREIGN ALUMINUM, GLASS OR STEEL.</p> <p>REV. 3/88</p> <p>EXHIBIT 9</p>						

SEE REVERSE SIDE FOR TERMS AND CONDITIONS

SIGNATURE	TELEPHONE	DATE
-----------	-----------	------

TITLE	FEIN	ADDRESS CHANGES TO BE NOTED ABOVE
-------	------	-----------------------------------

WHEN RESPONDING TO RFQ, INSERT NAME AND ADDRESS IN SPACE ABOVE LABELED 'VENDOR'



State of West Virginia  
 Department of Administration  
 Purchasing Division  
 2019 Washington Street East  
 Post Office Box 50130  
 Charleston, WV 25305-0130

# Request for Quotation

RFQ NUMBER  
**PRS09021**

PAGE  
**5**

ADDRESS CORRESPONDENCE TO ATTENTION OF:  
**JOHN ABBOTT**  
**304-558-2544**

VENDOR

\*709045245      304-744-0590  
**GARCIE R MARKER & SONS INC**  
**1119 JEFFERSON ROAD**  
  
**SOUTH CHARLESTON WV 25309**

SHIP TO

**PROTECTIVE SERVICES**  
**DIVISION OF**  
**BUILDING 1, ROOM 152-A**  
**1900 KANAWHA BOULEVARD, EAST**  
**CHARLESTON, WV**  
**25305**      **304-558-9911**

DATE PRINTED	TERMS OF SALE	SHIP VIA	F.O.B.	FREIGHT TERMS
01/13/2009				

BID OPENING DATE: **02/17/2009**      BID OPENING TIME **01:30PM**

LINE	QUANTITY	UOP	CAT. NO.	ITEM NUMBER	UNIT PRICE	AMOUNT
<p><b>NOTICE FOR ISSUANCE &amp; ACKNOWLEDGEMENT OF CONSTRUCTION PROJECT ADDENDA</b></p> <p><b>THE ARCHITECT/ENGINEER AND/OR AGENCY SHALL BE REQUIRED TO ABIDE BY THE FOLLOWING SCHEDULE IN ISSUING CONSTRUCTION PROJECT ADDENDA FOR STATE AGENCIES:</b></p> <p><b>(1) THE ARCHITECT/ENGINEER SHALL PREPARE THE ADDENDUM AND A LIST OF ALL PARTIES THAT HAVE PROCURED DRAWINGS AND SPECIFICATIONS FOR THE PROJECT. THE ADDENDUM AND LIST SHALL BE FORWARDED TO THE BUYER IN THE STATE PURCHASING DIVISION. THE ARCHITECT/ENGINEER SHALL ALSO SEND A COPY OF THE ADDENDUM TO THE STATE AGENCY FOR WHICH THE CONTRACT IS ISSUED.</b></p> <p><b>(2) THE BUYER SHALL SEND THE ADDENDUM TO ALL INTERESTED PARTIES AND, IF NECESSARY, EXTEND THE BID OPENING DATE. ANY ADDENDUM SHOULD BE RECEIVED BY THE BUYER WITHIN FOURTEEN (14) DAYS PRIOR TO THE BID OPENING DATE.</b></p> <p><b>(3) ALL ADDENDA SHOULD BE FORMALLY ACKNOWLEDGED BY ALL BIDDERS AND SUBMITTED TO THE STATE PURCHASING DIVISION. THE SAME RULES AND REGULATIONS THAT APPLY TO THE ORIGINAL BIDDING DOCUMENT SHALL ALSO APPLY TO AN ADDENDUM DOCUMENT. THE ONLY EXCEPTION MAY BE FOR AN ADDENDUM THAT IS ISSUED FOR THE SOLE PURPOSE OF CHANGING A BID OPENING TIME AND/OR DATE.</b></p> <p><b>REV. 11/96</b></p> <p><b>EXHIBIT 10</b></p> <p><b>ADDENDUM ACKNOWLEDGEMENT</b></p>						

SEE REVERSE SIDE FOR TERMS AND CONDITIONS

SIGNATURE	TELEPHONE	DATE
TITLE	FEIN	ADDRESS CHANGES TO BE NOTED ABOVE

WHEN RESPONDING TO RFQ, INSERT NAME AND ADDRESS IN SPACE ABOVE LABELED 'VENDOR'



State of West Virginia  
 Department of Administration  
 Purchasing Division  
 2019 Washington Street East  
 Post Office Box 50130  
 Charleston, WV 25305-0130

# Request for Quotation

RFQ NUMBER  
**PRS09021**

PAGE  
**6**

ADDRESS CORRESPONDENCE TO ATTENTION OF  
**JOHN ABBOTT**  
**304-558-2544**

**VENDOR**  
 \*709045245      304-744-0590  
**GARCIE R MARKER & SONS INC**  
**1119 JEFFERSON ROAD**  
**SOUTH CHARLESTON WV 25309**

**SHIP TO**  
**PROTECTIVE SERVICES**  
**DIVISION OF**  
**BUILDING 1, ROOM 152-A**  
**1900 KANAWHA BOULEVARD, EAST**  
**CHARLESTON, WV**  
**25305      304-558-9911**

DATE PRINTED <b>01/13/2009</b>	TERMS OF SALE	SHIP VIA	FOB	FREIGHT TERMS
-----------------------------------	---------------	----------	-----	---------------

BID OPENING DATE: **02/17/2009**      BID OPENING TIME **01:30PM**

LINE	QUANTITY	UOP	CAT NO	ITEM NUMBER	UNIT PRICE	AMOUNT
<p>I HEREBY ACKNOWLEDGE RECEIPT OF THE FOLLOWING CHECKED ADDENDUM(S) AND HAVE MADE THE NECESSARY REVISIONS TO MY PROPOSAL, PLANS AND/OR SPECIFICATION, ETC.</p> <p>ADDENDUM NOS.:</p> <p>NO. 1      .. X .....</p> <p>NO. 2      .. X .....</p> <p>NO. 3      .. .....</p> <p>NO. 4      .. .....</p> <p>NO. 5      .. .....</p> <p>I UNDERSTAND THAT FAILURE TO CONFIRM THE RECEIPT OF TH ADDENDUM(S) MAY BE CAUSE FOR REJECTION OF THE BIDS.</p> <p>VENDOR MUST CLEARLY UNDERSTAND THAT ANY VERBAL REPRESENTATION MADE OR ASSUMED TO BE MADE DURING ANY ORAL DISCUSSION HELD BETWEEN VENDOR'S REPRESENTATIVES AND ANY STATE PERSONNEL IS NOT BINDING. ONLY THE INFORMATION ISSUED IN WRITING AND ADDED TO THE SPECIFICATIONS BY AN OFFICIAL ADDENDUM IS BINDING.</p> <p><i>Garcie R. Marker</i> ..... SIGNATURE</p> <p>Garcie R. Marker &amp; Sons, Inc. .... COMPANY</p> <p>02/25/09 ..... DATE</p> <p>REV. 11/96</p>						

SEE REVERSE SIDE FOR TERMS AND CONDITIONS		
SIGNATURE	TELEPHONE	DATE
TITLE	FEIN	ADDRESS CHANGES TO BE NOTED ABOVE

WHEN RESPONDING TO RFQ, INSERT NAME AND ADDRESS IN SPACE ABOVE LABELED 'VENDOR'



State of West Virginia  
 Department of Administration  
 Purchasing Division  
 2019 Washington Street East  
 Post Office Box 50130  
 Charleston, WV 25305-0130

# Request for Quotation

RFQ NUMBER  
**PRS09021**

PAGE  
**7**

ADDRESS CORRESPONDENCE TO ATTENTION OF  
**JOHN ABBOTT**  
**304-558-2544**

\*709045245      304-744-0590  
**GARCIE R MARKER & SONS INC**  
**1119 JEFFERSON ROAD**  
  
**SOUTH CHARLESTON WV 25309**

**PROTECTIVE SERVICES**  
**DIVISION OF**  
**BUILDING 1, ROOM 152-A**  
**1900 KANAWHA BOULEVARD, EAST**  
**CHARLESTON, WV**  
**25305      304-558-9911**

DATE PRINTED <b>01/13/2009</b>	TERMS OF SALE	SHIP VIA	F.O.B.	FREIGHT TERMS
-----------------------------------	---------------	----------	--------	---------------

BID OPENING DATE: **02/17/2009**      BID OPENING TIME **01:30PM**

LINE	QUANTITY	UOP	CAT NO	ITEM NUMBER	UNIT PRICE	AMOUNT
<b>CONTRACTORS LICENSE</b>						
<p>WEST VIRGINIA STATE CODE 21-11-2 REQUIRES THAT ALL PERSONS DESIRING TO PERFORM CONTRACTING WORK IN THIS STATE MUST BE LICENSED. THE WEST VIRGINIA CONTRACTORS LICENSING BOARD IS EMPOWERED TO ISSUE THE CONTRACTORS LICENSE. APPLICATIONS FOR A CONTRACTORS LICENSE MAY BE MADE BY CONTACTING THE WEST VIRGINIA DIVISION OF LABOR CAPITOL COMPLEX, BUILDING 3, ROOM 319, CHARLESTON, WV 25305. TELEPHONE: (304) 558-7890.</p> <p>WEST VIRGINIA STATE CODE 21-11-11 REQUIRES ANY PROSPECTIVE BIDDER TO INCLUDE THE CONTRACTORS LICENSE NUMBER ON THEIR BID.</p> <p>BIDDER TO COMPLETE:</p> <p>CONTRACTORS NAME:      <i>Garcie R. Marker &amp; Sons, Inc.</i></p> <p>CONTRACTORS LICENSE NO.:      <i>WV001474</i></p> <p>THE SUCCESSFUL BIDDER WILL BE REQUIRED TO FURNISH A COPY OF THEIR CONTRACTORS LICENSE PRIOR TO ISSUANCE OF A PURCHASE ORDER/CONTRACT</p> <p style="text-align: center;"><b>APPLICABLE LAW</b></p> <p>THE WEST VIRGINIA STATE CODE, PURCHASING DIVISION RULES AND REGULATIONS, AND THE INFORMATION PROVIDED IN THE "REQUEST FOR QUOTATION" ISSUED BY THE PURCHASING DIVISION IS THE SOLE AUTHORITY GOVERNING THIS PROCUREMENT.</p> <p>ANY INFORMATION PROVIDED IN SPECIFICATION MANUALS, OR ANY OTHER SOURCE, VERBAL OR WRITTEN, WHICH CONTRADICTS</p>						

SEE REVERSE SIDE FOR TERMS AND CONDITIONS

SIGNATURE	TELEPHONE	DATE
TITLE	FEIN	ADDRESS CHANGES TO BE NOTED ABOVE

WHEN RESPONDING TO RFQ, INSERT NAME AND ADDRESS IN SPACE ABOVE LABELED 'VENDOR'





State of West Virginia  
 Department of Administration  
 Purchasing Division  
 2019 Washington Street East  
 Post Office Box 50130  
 Charleston, WV 25305-0130

# Request for Quotation

RFQ NUMBER  
**PRS09021**

PAGE  
**8**

ADDRESS CORRESPONDENCE TO ATTENTION OF  
**JOHN ABBOTT**  
**304-558-2544**

**\*709045245 304-744-0590**  
**GARCIE R MARKER & SONS INC**  
**1119 JEFFERSON ROAD**  
**SOUTH CHARLESTON WV 25309**

**PROTECTIVE SERVICES**  
**DIVISION OF**  
**BUILDING 1, ROOM 152-A**  
**1900 KANAWHA BOULEVARD, EAST**  
**CHARLESTON, WV**  
**25305 304-558-9911**

DATE PRINTED	TERMS OF SALE	SHIP VIA	F.O.B.	FREIGHT TERMS
01/13/2009				

BID OPENING DATE: **02/17/2009** BID OPENING TIME **01:30PM**

LINE	QUANTITY	UOP	CAT NO.	ITEM NUMBER	UNIT PRICE	AMOUNT
<p>OR ALTERS THE INFORMATION PROVIDED FROM THE SOURCES AS DESCRIBED IN THE ABOVE PARAGRAPH IS VOID AND OF NO EFFECT.</p> <p>BANKRUPTCY: IN THE EVENT THE VENDDR/CONTRACTOR FILES FOR BANKRUPTCY PROTECTION, THIS CONTRACT IS AUTOMATICALLY NULL AND VOID, AND IS TERMINATED WITHOUT FURTHER ORDER.</p> <p>REV. 1/2005</p> <p style="text-align: center;"><b>NOTICE</b></p> <p>A SIGNED BID MUST BE SUBMITTED TO:</p> <p style="text-align: center;">DEPARTMENT OF ADMINISTRATION          PURCHASING DIVISION          BUILDING 15          2019 WASHINGTON STREET, EAST          CHARLESTON, WV 25305-0130</p> <p>THE BID SHOULD CONTAIN THIS INFORMATION ON THE FACE OF THE ENVELOPE OR THE BID MAY NOT BE CONSIDERED:</p> <p>SEALED BID</p> <p>BUYER: JOHN ABBOTT-----</p> <p>REQ. NO.: PRS09021-----</p> <p>BID OPENING DATE: 2/12/2009-----</p> <p>BID OPENING TIME: 1:30 PM-----</p>						

SEE REVERSE SIDE FOR TERMS AND CONDITIONS

SIGNATURE	TELEPHONE	DATE
TITLE	FEIN	ADDRESS CHANGES TO BE NOTED ABOVE

WHEN RESPONDING TO RFQ, INSERT NAME AND ADDRESS IN SPACE ABOVE LABELED 'VENDOR'



State of West Virginia  
 Department of Administration  
 Purchasing Division  
 2019 Washington Street East  
 Post Office Box 50130  
 Charleston, WV 25305-0130

# Request for Quotation

RFQ NUMBER  
**PRS09021**

PAGE  
**9**

ADDRESS CORRESPONDENCE TO ATTENTION OF  
**JOHN ABBOTT**  
**304-558-2544**

VENDOR

\*709045245 304-744-0590  
**GARCIE R MARKER & SONS INC**  
**1119 JEFFERSON ROAD**  
  
**SOUTH CHARLESTON WV 25309**

SHIP TO

**PROTECTIVE SERVICES**  
**DIVISION OF**  
**BUILDING 1, ROOM 152-A**  
**1900 KANAWHA BOULEVARD, EAST**  
**CHARLESTON, WV**  
**25305 304-558-9911**

DATE PRINTED	TERMS OF SALE	SHIP VIA	F.O.B.	FREIGHT TERMS
<b>01/13/2009</b>				

BID OPENING DATE: **02/17/2009** BID OPENING TIME **01:30PM**

LINE	QUANTITY	UOP	CAT NO	ITEM NUMBER	UNIT PRICE	AMOUNT
PLEASE PROVIDE A FAX NUMBER IN CASE IT IS NECESSARY TO CONTACT YOU REGARDING YOUR BID: 304-746-5203 ----- PLEASE PRINT OR TYPE NAME OF PERSON TO CONTACT CONCERNING THIS QUOTE: Allen Marker -----						
***** THIS IS THE END OF RFQ PRS09021 ***** TOTAL:						<u>\$394,263.00</u>

SEE REVERSE SIDE FOR TERMS AND CONDITIONS

SIGNATURE	TELEPHONE	DATE
TITLE	FEIN	ADDRESS CHANGES TO BE NOTED ABOVE

WHEN RESPONDING TO RFQ, INSERT NAME AND ADDRESS IN SPACE ABOVE LABELED 'VENDOR'

**Security Bollard System  
Remote Controlled and Manually Removable**

Location: West Virginia Capitol Complex  
Charleston West Virginia

For: State of West Virginia  
Department of Military Affairs and Public Safety  
Division of Protective Services

#### SPECIFICATIONS

The Acquisition and Contract section for the Purchasing Division "State" for the West Virginia Division of Protective Services of the Department of Military Affairs and Public Safety is requesting a price quote for the purchase, installation and maintenance of an Automatic Remote Controlled Retractable Bollard systems, as well as additional External Padlock Removable Bollards. All bollards shall be 12" in diameter and have an above ground height of 36". All bollards will be installed with a strip footing with a rebar cage tied into the bollard. All bollards will be mounted in concrete. All bollards would be manufactured out of 3/16 stainless steel with a #4 satin finish.

Three locations have been identified in the Capitol Complex for immediate installation of bollard systems of various configurations.

Remote Controlled Systems will be installed at three locations in the Capitol Complex External Padlock Removable Bollards will be used to supplement these systems.

A mandatory pre-bid conference will be held on Tuesday, January 27, 2009; 11:00 AM in the Purchasing Division Conference Room at 2019 Washington Street, East Charleston, West Virginia. A walking tour of the campus to identify the specific locations of the Bollard systems will take place as a part of this conference.

The Automatic Retractable Bollards system shall work in-conjunction with an access control system. The current system is GE Facility Commander. The bollards will also be

controlled via remote control buttons in two command center locations. Fiber optic infrastructure connectivity between the bollard location and the access control system is in place. The successful bidder shall provide all moving part mechanism's to make the retractable bollards operable to be lowered and raised.

The External Padlock Removable Bollards will contain 6 bollards. Single keyed padlocks shall be furnished as a part of the quote.

- The basic unit shall consist of a single, integrated, self contained bollard system for each vertical lift bollard. The only external components are remote controls and other control options, radio frequency receivers, and optional safety loops.
- The bollard installation/containment unit shall be constructed of stainless steel, as is the vertical lift unit itself.

## 1.0 SYSTEM CONFIGURATION

1.1 Bollard Arrangement. The system shall have a total of 6 Bollards arrayed in accordance with either 1.1.1 & 1.1.2.

Multiple bollard units operating in sets. One of the Bollard systems shall have 6 units. It will be segregated to allow three units to operate as a system and the other three units to be operated as a system. One of the Bollard systems shall have 6 units and all operate as a system. One of the Bollard systems shall have 3 units. Each set of bollards systems shall have its own controls and operate independently from each other set within the system.

1.2 Construction. Each bollard unit shall be housed in a below ground, stainless steel installation/containment box housing all bollard components (motor, pump, tank, battery, etc), except for external controls, safety loop, radio frequency receiver, and low voltage lines for recharging the batteries. Installation of a containment box shall also house the seamless stainless steel cylindrical RAM Bollard capable of being extended/raised to an above grade position. The extended position shall present a formidable obstacle to approaching vehicles. Upon impact, forces shall first be absorbed by the RAM Bollard and then transmitted to the foundation of the unit.

1.3 Containment box cover plate. Containment box must be covered by a lift-off, non-skid, stainless steel, and tamper proof cover plate. Cover plate shall have handles and be removable to provide access to all internal components of the bollard system.

1.4 Containment Box Seal. Containment box shall be sealed in such a way that leaves, sand, grit, and other environmental debris shall not infiltrate a bollard unit.

1.5 Bollard Height. The extended bollard height shall be 36 inches measuring from the grade level cover plate to the top of the extended bollard.

1.6 Bollard Dimensions. Bollard shall be 6.4 to 6.6 inches in diameter.

- 1.7 Finish. For corrosion protection, the entire below grade containment box and the above grade extendable and retractable portion of the bollard system shall be made of stainless steel. The roadway cover plate shall be stainless steel with a non-skid surface.
- 1.8 Dual light ring. The top of the extendable bollard shall include a dual light ring. The top ring will consist of 12 red light-emitting diode (LED) lights with apertures cut at a 90 degree angle to the cylinder. The lower ring will consist of 12 white LED lights with apertures cut at a 40 degree angle toward the ground.
- 1.9 Gel Pack Battery Power. Internal motor shall be driven by a 12 Volt DC Gel Pack Battery with re-charger. Battery and recharger must be located inside the containment box. Recharger shall be connected to low voltage wiring direct current. Battery must ensure that, in the event of a power outage, the bollard can continue to operate for at least 40 cycles (one extension and one retraction) before the battery needs to be recharged.
- 1.10 Power Consumption. Bollard unit power consumption shall not exceed 2 amps.
- 1.11 Control Circuit. The control circuit must be housed and integrated with the system inside the below grade bollard containment box. The control circuit must interface with all related automatic gates and loops.
- 1.12 Sump Pump. An automatic sump pump shall reside inside the containment box. This sump pump shall automatically remove accumulated condensation from the containment box and discharge said condensation into the surrounding aquifer. Vendor shall provide a 12 Volt, 2 Amp, 500 Gallon per hour pump. It shall be a brand and model standard to the industry; for parts and repair issues in the future.
- 1.13 Optional Safety Loop. A bollard vehicle detector safety loop shall be available to prevent bollard units from being accidentally raised under an authorized vehicle. The output of the detector shall delay any bollard rise signal when a vehicle is over the loop.

## 2.0 PERFORMANCE

### 2.1 Stopping Power

Bollard shall be designed to meet or exceed U.S. State Department K4 ratings: 30 mph vehicle with impact of 450,000 foot lbs. of kinetic energy. Bollards shall provide security and positive control of normal traffic in both directions by providing an almost insurmountable obstacle to non-armored or non-tracked vehicles. The bollard shall be designed to stop a vehicle approaching from any direction.

- 2.2 Speed of operation. Bollard units shall extend or retract in 8 to 10 seconds.

- 2.3 Frequency of Operation. Bollard shall be capable of 60 complete up/down cycles per hour.
- 2.4 Power Failure. In the event of a power failure, the bollards system shall continue to operate for a minimum of 40 cycles without the need for a recharge.
- 2.5 Operation in sub zero weather. Bollard shall have been tested to operate successfully at 36 degrees below zero Fahrenheit after 12 hours exposure to the same temperature.

### **3.0 QUALITY ASSURANCE PROVISIONS**

- 3.1 Testing. Upon completion, the bollard system will be fully tested upon installation completion, in accordance to manufacturer's guidelines and specification. In addition to complete cycle testing to verify function and operating speeds, the following checks shall be made:
  - 3.2 Identification. A nameplate with manufacturer's name, model, serial number, and year shall be located on the bollard roadway cover plate.
  - 3.3 Workmanship. The bollard shall have a workmanlike appearance.
  - 3.4 Dimensions. Dimensions shall be checked against plans and order specifications.

### **4.0 MANUFACTURER'S DATA**

- 4.1 Drawings and installation data. Detailed drawings and project schedule shall be provided within 10 working days upon request. The bollard system drawings and installation, maintenance, and operating manuals shall be provided within 4 weeks upon completion of the project. All documents shall be included in the price quotation.

### **5.0 WARRANTY**

- 5.1 Vendor shall warrant all parts and labor for a period of one (1) year from acceptance of the project. A quotation for Annual Maintenance/Warranty shall be provided on the price quote form attached. The price quote shall remain the same for a period of three (3) years. The maintenance will become effective, and vendor may invoice on a monthly basis in arrears, at the end of the one year warranty period.

## **6.0 EXTERNAL REMOVABLE LOCK ABLE BOLLARDS**

The basic unit consists of 3 parts: a cylindrical bollard the lower portion of which is a narrow tongue base, a socket to be embedded into the pavement, and a socket cap for covering and protecting the bollard socket while the bollard is removed.

In order to provide for multiple sites for deploying removable bollards, the 3 bollard parts are available, not only as sets, but as individual pieces.

External Padlock Removable Bollards will be used to supplement the Automatic Bollards at one locations on campus

## **7.0 SYSTEM CONFIGURATION**

**7.1 Bollards.** The system shall consist of 3 bollards.

**7.2 Bollard Sockets.** The system shall consist of 3 bollard sockets.

**7.3 Socket Caps.** The system shall consist of 3 socket caps.

**7.4 General Construction.** Bollard socket shall be embedded in a below ground, reinforced concrete footer. Lower segment of the bollard shall fit snugly into the bollard socket so that it stands perpendicular to a level plane. When the bollard is removed, a socket cap shall be available to cover the bollard socket opening.

**7.5 Bollard Construction.** Bollard material. Except for its LED cap (the light fixture positioned at and attached to the top of the bollard), Bollard shall be 100% stainless steel.

**7.6 Bollard locking pins.** The bollard shall have 2 diametrically opposed locking pins protruding from and positioned approximately 2 inches below the bollard base ring. These locking pins shall fit precisely into 2 locking pin receivers in the bollard socket.

**7.7 Bollard shall include a tamper proof lock.**

**7.8 Lock mechanism shall be positioned approximately 2 inches below the lift ring and 16 inches above the base ring.**

**7.9 Lock shall prevent removal of the bollard from the bollard socket.**

**7.10 Bollard locking mechanism shall be operated by a wrench key capable of opening and closing the tamper proof lock.**





**Security Bollard System**

**PRICE QUOTE**

3 Automatic Remote Controlled Retractable Bollard systems: \$ \_\_\_\_\_

Annual Maintenance/Warranty for 3 Automatic Remote  
Controlled Retractable Bollard systems: \$ \_\_\_\_\_

6 External Padlock Removable Bollards: \$ \_\_\_\_\_

**Total:** \$ \_\_\_\_\_



State of West Virginia  
 Department of Administration  
 Purchasing Division  
 2019 Washington Street East  
 Post Office Box 50130  
 Charleston, WV 25305-0130

# Request for Quotation

RFQ NUMBER  
 PRS09021

PAGE  
 1

ADDRESS CORRESPONDENCE TO ATTENTION OF  
 JOHN ABBOTT  
 304-558-2544

PROPERTY

\*709045245      304-744-0590  
 GARCIE R MARKER & SONS INC  
 1119 JEFFERSON ROAD  
 SOUTH CHARLESTON WV 25309

SHIP TO

PROTECTIVE SERVICES  
 DIVISION OF  
 BUILDING 1, ROOM 152-A  
 1900 KANAWHA BOULEVARD, EAST  
 CHARLESTON, WV  
 25305      304-558-9911

DATE PRINTED	TERMS OF SALE	SHIP VIA	F.O.B.	FREIGHT TERMS
01/27/2009				

BID OPENING DATE: 02/17/2009      BID OPENING TIME 01:30PM

LINE	QUANTITY	UOP	CAT. NO.	ITEM NUMBER	UNIT PRICE	AMOUNT
ADDENDUM #01						
THIS ADDENDUM IS ISSUED TO ADD A SECONDARY PRE-BID DUE TO WINTER WEATHER CONDITIONS.						
SECOND PRE-BID: 2/5/2009; 11:00 AM						
0001	1	LS		550-43		
BOLLARD SYSTEM INSTALLATION						
***** THIS IS THE END OF RFQ PRS09021 ***** TOTAL:						

SEE REVERSE SIDE FOR TERMS AND CONDITIONS

SIGNATURE	TELEPHONE	DATE
-----------	-----------	------

TITLE	FEIN	ADDRESS CHANGES TO BE NOTED ABOVE
-------	------	-----------------------------------

WHEN RESPONDING TO RFQ, INSERT NAME AND ADDRESS IN SPACE ABOVE LABELED 'VENDOR'



State of West Virginia  
 Department of Administration  
 Purchasing Division  
 2019 Washington Street East  
 Post Office Box 50130  
 Charleston, WV 25305-0130

# Request for Quotation

RFQ NUMBER
PRS09021

PAGE
1

ADDRESS CORRESPONDENCE TO ATTENTION OF
JOHN ABBOTT 304-558-2544

VENDOR

\*709045245      304-744-0590  
 GARCIE R MARKER & SONS INC  
 1119 JEFFERSON ROAD  
  
 SOUTH CHARLESTON WV 25309

SHIP TO

PROTECTIVE SERVICES  
 DIVISION OF  
 BUILDING 1, ROOM 152-A  
 1900 KANAWHA BOULEVARD, EAST  
 CHARLESTON, WV  
 25305      304-558-9911

DATE PRINTED	TERMS OF SALE	SHIP VIA	F.O.B.	FREIGHT TERMS
02/13/2009				

BID OPENING DATE: 02/25/2009      BID OPENING TIME 01:30PM

LINE	QUANTITY	UOP	CAT NO	ITEM NUMBER	UNIT PRICE	AMOUNT
ADDENDUM #02						
THIS ADDENDUM IS ISSUED TO CLARIFY, MODIFY, AND ADD TO THE ORIGINAL SPECIFICATIONS, PER THE ATTACHED DOCUMENTATION, AND TO EXTEND THE BID OPENING.						
REVISED BID OPENING: 2/25/2009; 1:30 PM						
0001	1	LS		550-43		
BOLLARD SYSTEM INSTALLATION						
***** THIS IS THE END OF RFQ PRS09021 ***** TOTAL:						\$394,263.00

SEE REVERSE SIDE FOR TERMS AND CONDITIONS

SIGNATURE	TELEPHONE	DATE
TITLE	FEIN	ADDRESS CHANGES TO BE NOTED ABOVE

WHEN RESPONDING TO RFQ, INSERT NAME AND ADDRESS IN SPACE ABOVE LABELED 'VENDOR'



State of West Virginia  
 Department of Administration  
 Purchasing Division  
 2019 Washington Street East  
 Post Office Box 50130  
 Charleston, WV 25305-0130

# Request for Quotation

RFQ NUMBER  
 PRS09021

PAGE  
 1

ADDRESS CORRESPONDENCE TO ATTENTION OF  
 JOHN ABBOTT  
 304-558-2544

VENDOR

\*709045245      304-744-0590  
 GARCIE R MARKER & SONS INC  
 1119 JEFFERSON ROAD  
 SOUTH CHARLESTON WV 25309

SHIP TO

PROTECTIVE SERVICES  
 DIVISION OF  
 BUILDING 1, ROOM 152-A  
 1900 KANAWHA BOULEVARD, EAST  
 CHARLESTON, WV  
 25305      304-558-9911

DATE PRINTED	TERMS OF SALE	SHIP VIA	F.O.B.	FREIGHT TERMS
02/13/2009				

BID OPENING DATE: 02/25/2009      BID OPENING TIME 01:30PM

LINE	QUANTITY	UOP	CAT NO	ITEM NUMBER	UNIT PRICE	AMOUNT
ADDENDUM #02						
THIS ADDENDUM IS ISSUED TO CLARIFY, MODIFY, AND ADD TO THE ORIGINAL SPECIFICATIONS, PER THE ATTACHED DOCUMENTATION, AND TO EXTEND THE BID OPENING.						
REVISED BID OPENING: 2/25/2009; 1:30 PM						
0001	1	LS		550-43		
BOLLARD SYSTEM INSTALLATION						
***** THIS IS THE END OF RFQ PRS09021 ***** TOTAL: _____						

SEE REVERSE SIDE FOR TERMS AND CONDITIONS

SIGNATURE		TELEPHONE		DATE
TITLE	FEIN	ADDRESS CHANGES TO BE NOTED ABOVE		

WHEN RESPONDING TO RFQ, INSERT NAME AND ADDRESS IN SPACE ABOVE LABELED 'VENDOR'

## PRS09021 Bollard Installation

### Addendum #02

#### Clarifications:

- Revised bid opening date: 2/25/2009; 1:30 PM
- Successful bidder shall have 90 days to complete the project upon receipt of the Notice to Proceed notification
- Specifications - Page 10, paragraph 1: Bollards shall be 6 ½" in diameter; Addition: Retractable bollards shall be spaced 6 ½' on centers; removable bollards shall be spaced 5' on centers
- Paragraph 2: Four locations have been identified on the attached campus map – Location 1: Bollards shall be 3 retractable units working as one system, off center, and 3 removable, opposite side; Location 2 shall be 6 retractable units working as one system; Location 3 shall be 6 retractable units: 3 units working as one system, and 3 units working as one system; Location 4 shall be 6 retractable units: 3 units working as one system, and 3 units working as one system - (total is 21 retractable and 3 removable)
- Paragraph 5: The Command Center is located in the West Wing Basement of the Capitol building; Location 4 shall have a local control in order for the guard to operate the retractable bollards in location 4 only; vendors shall consider digging a maximum of 10' for connection to the existing underground fiber cabling; all underground fiber and power cabling shall be buried in conduit approximately 24" in depth.
- Paragraph 6 – see above for number of bollards; Addition: contractor will be responsible to install a 12"X12"X4" (approximate size) stainless steel weatherproof junction box at the base of each light pole, from which power will be obtained – power will be obtained from the existing light poles; and contractor shall be responsible to dig a maximum of 30', and run power from the junction box to the retractable bollard units – the junction box shall be buried so the top lid shall be exposed for accessibility – all cabling shall be in commercial grade metal conduit

#### 1.0 SYSTEM CONFIGURATION

- 1.1 - SEE ABOVE bullet point 3
- 1.6 – 6 ½" inches in diameter, as stated above
- All lights shall be clear/white LED lights on the retractable and removable units; and shall have a dusk to dawn control located in the junction box at each location
- 1.12 – Sump Pump – sump pump shall remain as stated in the specifications

## **5.0 WARRANTY**

- **5.1 – Maintenance will not be a part of this quotation – also see revised bid form**

## **7.0 SYSTEM CONFIGURATION**

- **7.1 Bollards - The system shall consist of 21 retractable and 3 removable bollards – removable bollards shall match the retractable bollards in all aspects, except for the base configuration difference between the retractable and removable**
- **7.4 General Construction – see additional drawings attached**

## **CLARIFICATION:**

- **Removable bollards have sockets that shall be 18” deep**
- **Excess dirt shall be left around excavated areas for settling purposes – excavated areas shall be compacted where applicable, leaving 6 inches of loose material for seeding purposes**
- **All dirt excavated areas shall be dressed back to original contour, seeded, and straw added two layers thick. Grass seed shall be used that is the same as the existing grass in the area**

## **DEBRIS REMOVAL**

- **All excess debris shall be removed from the campus grounds and discarded in accordance to all state and local laws**

**DRUG FREE WORKPLACE CONFORMANCE AFFIDAVIT form is required to be completed and submitted with the bid – failure to submit this form with the bid is automatic disqualification from the bidding process**

- Fiber Optics Connection (x 4; once fro each location):
  - Metrotek Inc. Transmitter - Part No. XC1000A-1 or equal
  - Metrotek, Inc. Receiver - RC-1000A-1 or equal
- Carson Industries: [http://www.carsonind.com/PDF/Util\\_Infra/H\\_H2436.pdf](http://www.carsonind.com/PDF/Util_Infra/H_H2436.pdf); see specific Heavy Duty Vaults outlined below
  - Inside of Heavy Duty Vault all wiring junctions shall be watertight.
  - All waterproof junction boxes (which go inside Vault) shall be supplied and pre-configured by vendor; contractor shall provide the connections
  - Incoming flex conduit supplied by vendor shall be 30 feet long per Ram bollard

Location 1: 3 Rams Bollards, 3 Bobcat Removable Bollards: Carson Industries H2436-24 Heavy Duty Vault and H2436-P1 Cover or equal

1. Incoming Fiber Optic
2. Incoming 110V Power which feeds 1 transformer to Bobcats and Rams
3. Incoming control conduit from bollard set one (conduit supplied by bollard vendor)
  - a. Control Wire
  - b. Battery Wire
4. Incoming control conduit from bollard set two (conduit supplied by bollard vendor)
  - a. Control Wire
  - b. Battery Wire
5. Incoming conduit from loop

Location 2: 6 Ram Bollards operating as a single set: Carson Industries H2436-24 Heavy Duty Vault and H2436-P1 Cover or equal

1. Incoming Fiber Optic
2. Incoming 110V Power
3. Incoming control conduit from set of bollards (conduit supplied by bollard vendor)
  - Control Wire
  - Battery Wire
4. Incoming conduit from loop

Location 3: Two independently operated sets of 3 Ram Bollards: Carson Industries H3048-24 Heavy Duty Vault and H3048-P1 Cover or equal

6. Incoming Fiber Optic
7. Incoming 110V Power
8. Incoming control conduit from bollard set one (conduit supplied by bollard vendor)
  - a. Control Wire
  - b. Battery Wire
9. Incoming control conduit from bollard set two (conduit supplied by bollard vendor)
  - a. Control Wire
  - b. Battery Wire
10. Incoming conduit from loop

Location 4: Two independently operated sets of 3 Ram Bollards with Fiber Optics, RF Remote Control, and Booth Switch: Carson Industries H3048-24 and H3048-P1 Cover or equal

5. Incoming Fiber Optic
6. Incoming 110V Power
7. Outgoing above ground antenna conduit to terminate in guard shack
8. Incoming conduit from bollard set one (conduit supplied by bollard vendor)
  - Control Wire
  - Battery Wire
9. Incoming conduit from bollard set two (conduit supplied by bollard vendor)
  - Control Wire
  - Battery Wire
10. Incoming conduit from loop
11. Bollards for Location 4 shall include 6 remote controls for each set of bollards (remote controls supplied by bollard vendor)

Also: Please replace 500 gallon per hour sump pump with 180 gallon per hour sump pump.



# Ram Bollard

## Recommended Installation Instructions

You need to excavate a 32" X 20" X 54" deep hole, if installing multiple units, you could trench 32" wide X 54" deep. Be sure to add at least 4" on each side of the units and the BOLLARD is oriented in correct position.

Use lifting hooks located on the out side of the BOLLARD installation box and lower into hole, make sure the adobe bricks are in place and the top of the BOLLARD is level with the grade. Use shims to assure the BOLLARD is all square and level.

Using the flexible conduit supplied, run conduit underground to the above grade control box. The control box should be located as close to the BOLLARD installation as possible and located in a out of the way secure location. Wire to controls following instructions located inside the control box. Operate the BOLLARD to insure proper electrical connection.

To install the safety loop closely follow the instruction attached to the loop. **Important:** run the loop connection wire thru a separate conduit, do not use BOLLARD conduit. After installed, pull a vehicle over the loop wire and retest BOLLARD, if unit will not start up, phase 1 is correctly installed. Remove vehicle and check BOLLARD operation, if BOLLARD cycles correctly, safety loop is installed.

After spacing and level is verified, be sure to lower BOLLARD before pouring concrete, in some cases you might need to vibrate concrete to assure footer under unit is compacted. Before matching grade composition, use expansion joint filler around top of BOLLARD to complete the installation.

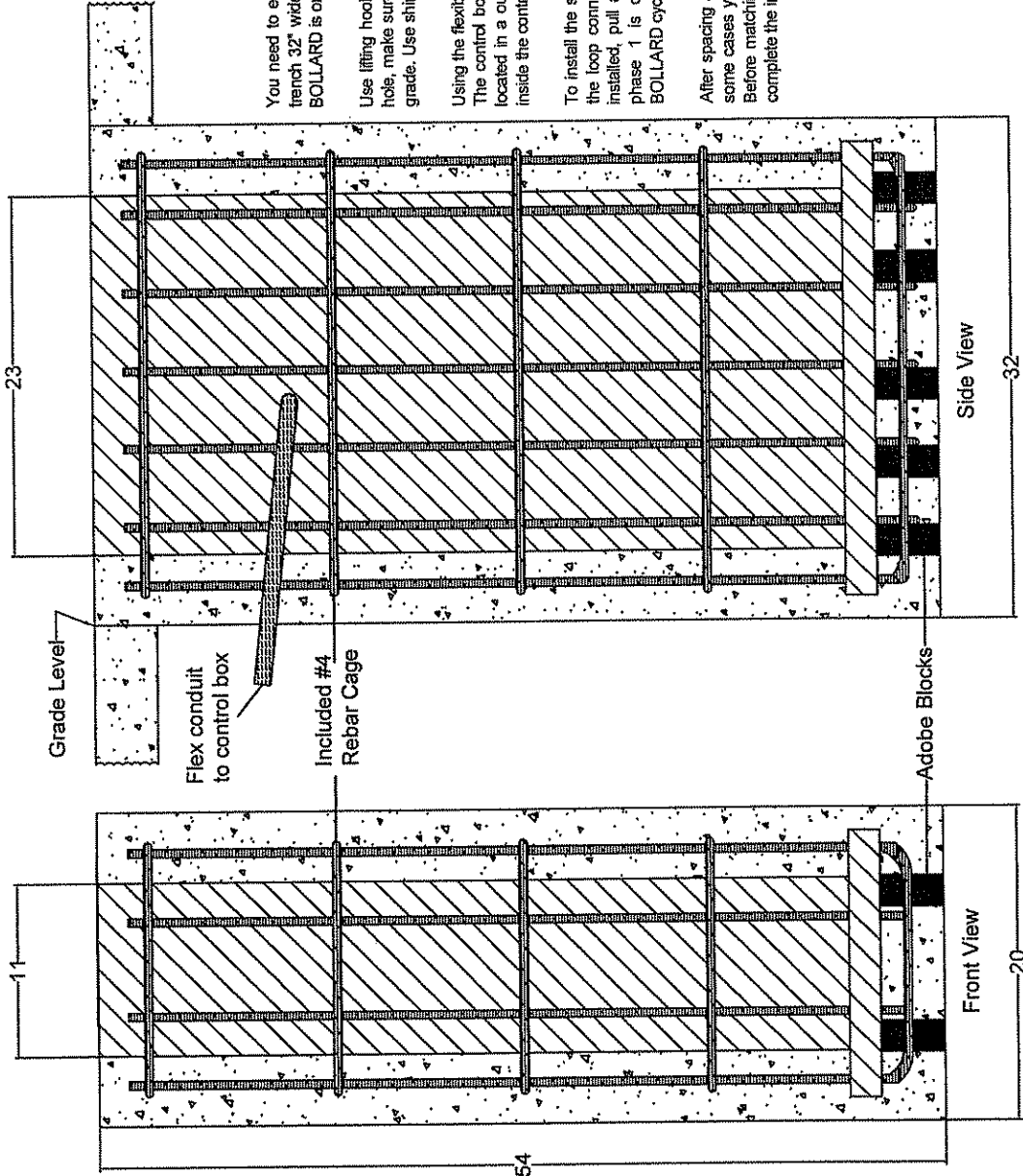

Hole dimensions, concrete, and rebar are engineered for bollard strength rating

# Bobcat Bollard 6 1/2" Diameter

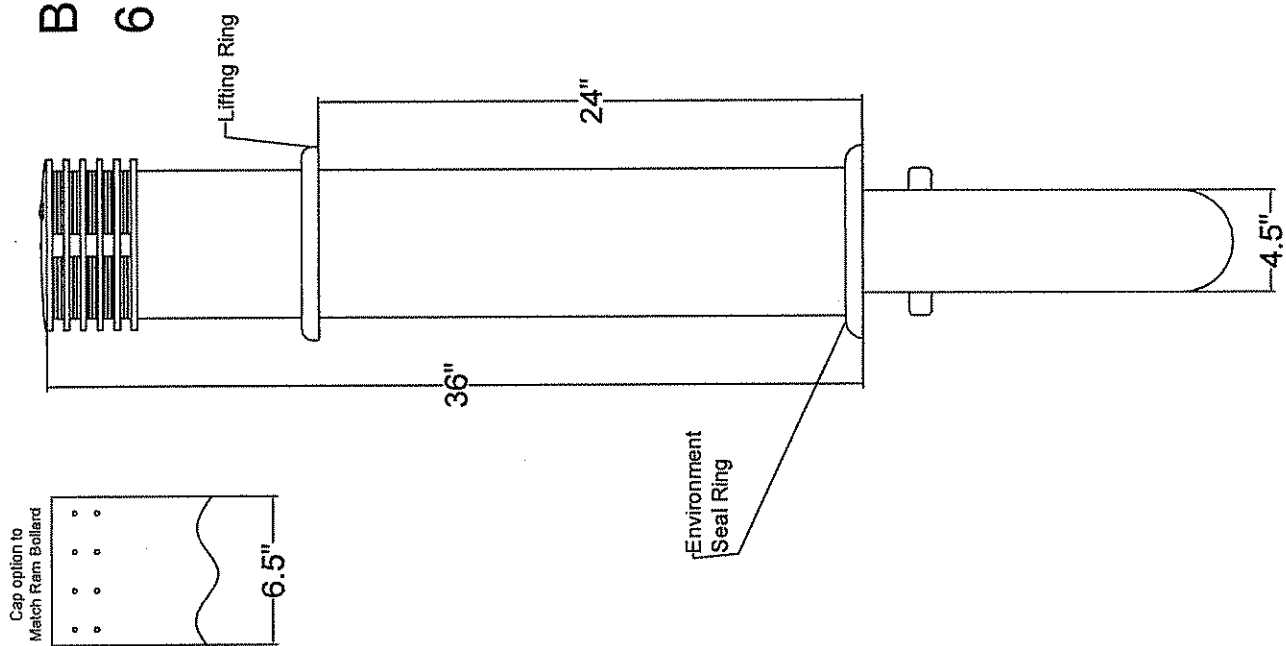

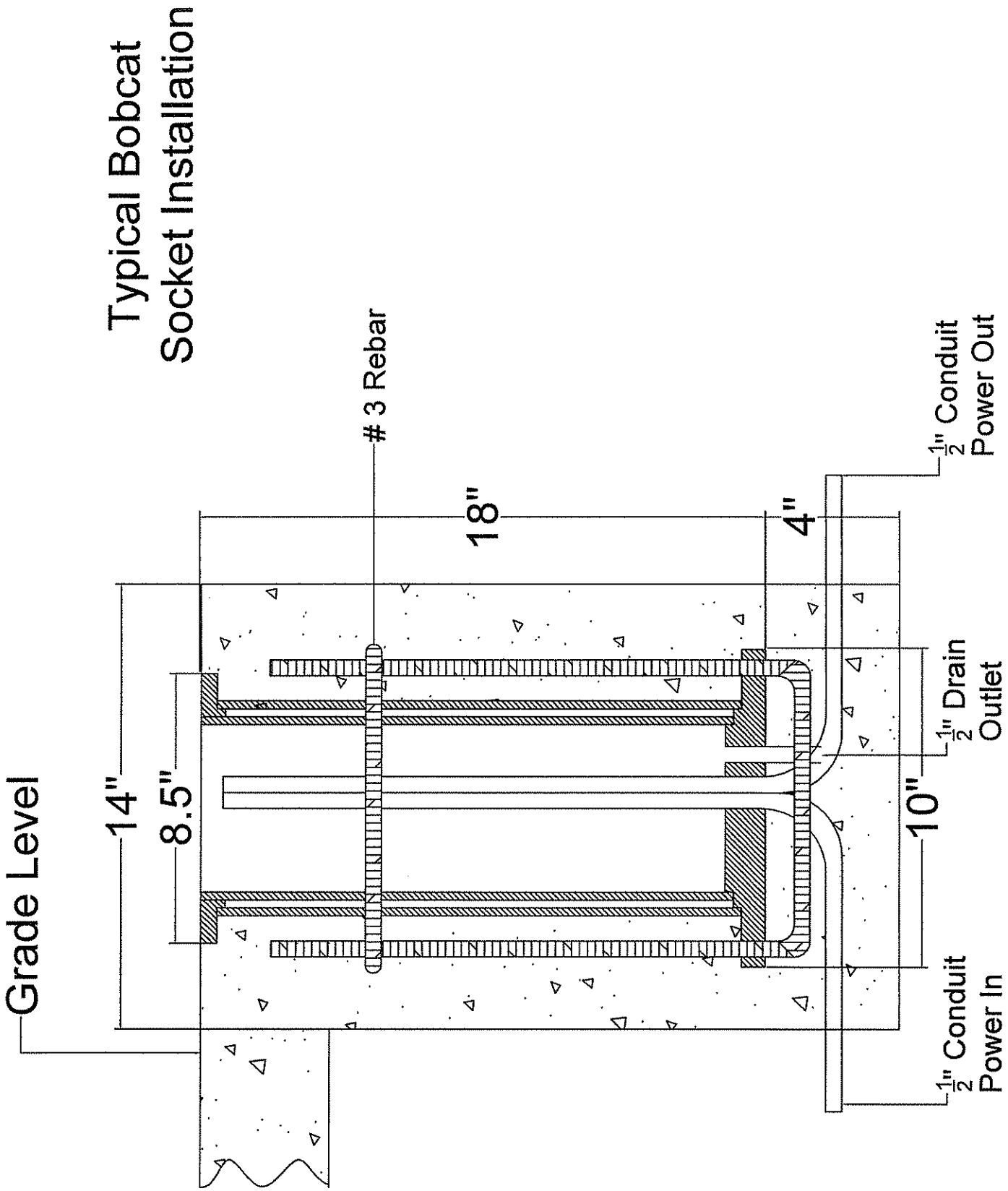

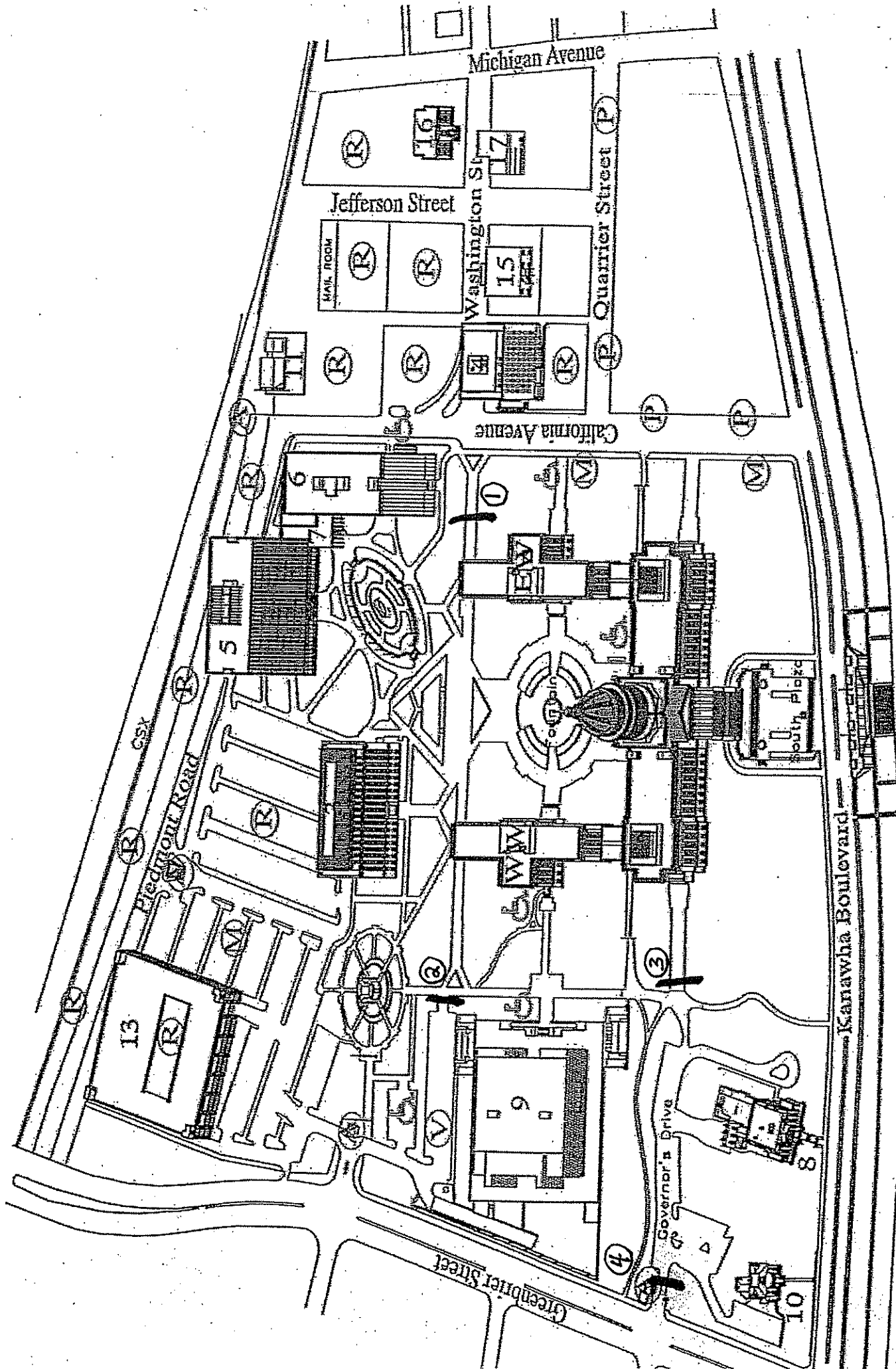

WEST VIRGINIA STATE CAPITOL DIRECTORY



**State of West Virginia  
DRUG FREE WORKPLACE CONFORMANCE AFFIDAVIT  
West Virginia Code §21-1D-5**

**STATE OF WEST VIRGINIA,**

**COUNTY OF \_\_\_\_\_, TO-WIT:**

I, \_\_\_\_\_, after being first duly sworn, depose and state as follows:

- 1. I am an employee of \_\_\_\_\_; and,  
(Company Name)
- 2. I do hereby attest that \_\_\_\_\_  
(Company Name)

maintains a valid written drug free workplace policy and that such policy is in compliance with **West Virginia Code §21-1D-5**.

The above statements are sworn to under the penalty of perjury.

\_\_\_\_\_  
(Company Name)

By: \_\_\_\_\_

Title: \_\_\_\_\_

Date: \_\_\_\_\_

Taken, subscribed and sworn to before me this \_\_\_\_\_ day of \_\_\_\_\_.

By Commission expires \_\_\_\_\_

(Seal)

\_\_\_\_\_  
(Notary Public)

**THIS AFFIDAVIT MUST BE SUBMITTED WITH THE BID IN ORDER TO COMPLY WITH WV CODE PROVISIONS. FAILURE TO INCLUDE THE AFFIDAVIT WITH THE BID SHALL RESULT IN DISQUALIFICATION OF THE BID.**

**SIGN IN SHEET**

PLEASE PRINT

**PRE-BID SIGN-IN SHEET / PLEASE LEAVE A BUSINESS CARD - PRS09021 - 2/05/2009; 11:00 AM**

FIRM & REPRESENTATIVE NAME	MAILING ADDRESS	TELEPHONE & FAX NUMBERS
Company: <u>Garcie R. Marker &amp; Sons Inc</u>	<u>1119 Jefferson Rd</u>	PHONE <u>744 0590</u>
Rep: <u>Allen Marker</u>	<u>Sv. Chas. Wv. 25309</u>	TOLL FREE
Email Address: <u>GRmarkerSons@aol.com</u>		FAX <u>746 5203</u>
Company: <u>NEIGHBORHOOD CONSTRUCTION</u>	<u>1216 SEVENTH AVE.</u>	PHONE <u>(304) 525-5181</u>
Rep: <u>DAVID R. Mc CARTY</u>	<u>P.O. Box 1214</u>	TOLL FREE
Email Address: <u>dmccarty@neighborgall.com</u>	<u>HURTINGTON, WV 25707</u>	FAX <u>(304) 525-7795</u>
Company: <u>All Quality</u>	<u>PO BOX 7169</u>	PHONE <u>304 776 9473</u>
Rep: <u>Jason Davis</u>	<u>Cross Lanes, WV 25356</u>	TOLL FREE
Email Address: <u>AllQuality LLC@aol.com</u>		FAX <u>304 776 9474</u>
Company: <u>Shamblin Const. Inc.</u>	<u>334-C Call Rd.</u>	PHONE <u>304 984 1948</u>
Rep: <u>Daniel + Ralph Shamblin</u>	<u>Sissonville, WV 25320</u>	TOLL FREE
Email Address: <u>Shamblin Cons 2@Aol.com</u>		FAX <u>304 984 2303</u>
Company: <u>MT STATE BUILDING AUTOMATION</u>	<u>6444 SISSONVILLE DR</u>	PHONE <u>304 984-0415</u>
Rep: <u>CRAIG CARTER</u>	<u>SISSONVILLE, WV 25320</u>	TOLL FREE
Email Address: <u>ccarter@msbautomation.com</u>		FAX <u>304 984-0124</u>

**SIGN IN SHEET**

PLEASE PRINT

PRE-BID SIGN-IN SHEET / PLEASE LEAVE A BUSINESS CARD - PRS09021 - 2/05/2009; 11:00 AM

FIRM & REPRESENTATIVE NAME	MAILING ADDRESS	TELEPHONE & FAX NUMBERS
Company: <u>Electronic Speciality</u>	<u>1325 Durbar Ave</u>	PHONE <u>766-6277</u>
Rep: <u>Marshall Ellison</u>	<u>Durbar WV 25064</u>	TOLL FREE
Email Address: <u>marshall@electronicsspecialty.com</u>		FAX <u>766-6270</u>
Company: _____		PHONE _____
Rep: _____		TOLL FREE _____
Email Address: _____		FAX _____
Company: _____		PHONE _____
Rep: _____		TOLL FREE _____
Email Address: _____		FAX _____
Company: _____		PHONE _____
Rep: _____		TOLL FREE _____
Email Address: _____		FAX _____

SIGN IN SHEET

PLEASE PRINT

PRE-BID SIGN-IN SHEET / PLEASE LEAVE A BUSINESS CARD - PRS09021 - 1/27/2009; 11:00 AM

FIRM & REPRESENTATIVE NAME	MAILING ADDRESS	TELEPHONE & FAX NUMBERS
Company: <u>NEIGHBORGALL CONSTRUCTION</u>	<u>P.O. Box 281, HUNTINGTON WV</u>	PHONE <u>304-525-5181</u>
Rep: <u>Jessica Robinson</u>	<u>25707-0281</u>	TOLL FREE
Email Address: <u>jrobinson@neighborgall.com</u>		FAX <u>304-525-7795</u>
Company: <u>Electronic Specialty Co</u>	<u>1325 Dunbar Ave.</u>	PHONE <u>304-766-6277</u>
Rep: <u>Marshall Ellison</u>	<u>Dunbar WV 25064</u>	TOLL FREE
Email Address: <u>electronic-specialty.com</u>		FAX <u>304-766-6270</u>
Company: <u>MOUNTAIN STATE BROS. AUTOMATION</u>	<u>6444 SISSONVILLE DR.</u>	PHONE <u>304-984-0415</u>
Rep: <u>CRAIG CARTER</u>	<u>SISSONVILLE WV 25320</u>	TOLL FREE
Email Address: <u>ccarter@msbautomation.com</u>		FAX <u>304-984-0124</u>
Company: <u>OVAL CONSTRUCTION MGMT, LLC</u>	<u>P.O. Box 401</u>	PHONE <u>304-347-8820</u>
Rep: <u>Rick Bernard</u>	<u>Charleston WV 25322</u>	TOLL FREE
Email Address: <u>bernard@ovalconstruction.com</u>		FAX <u>(304)347-8821</u>
Company: <u>Danhill Const. Co.</u>	<u>P.O. Box 685</u>	PHONE <u>304-632-1600</u>
Rep: <u>Dan Hill</u>	<u>Gauley Bridge, W.Va.</u>	TOLL FREE
Email Address: <u>rdanhill@hotmail.com</u>	<u># 5085</u>	FAX <u>304-632-1501</u>



SIGN IN SHEET

PLEASE PRINT

PRE-BID SIGN-IN SHEET / PLEASE LEAVE A BUSINESS CARD - PRS09021 - 1/27/2009; 11:00 AM

FIRM & REPRESENTATIVE NAME	MAILING ADDRESS	TELEPHONE & FAX NUMBERS
Company: <u>Danhill Construction Company</u>	<u>P.O. Box 685</u>	PHONE <u>304-632-1600</u>
Rep: <u>Chas Dozier</u>	<u>Conlay Budge, <del>Box</del> <sup>wk</sup> 25085</u>	TOLL FREE <u>o</u>
Email Address: <u>C.dozier@pyaho.com</u>		FAX <u>304-632-1501</u>
Company: <u>Garcie R-Marker &amp; Sons Inc</u>	<u>1119 Jefferson Rd.</u>	PHONE <u>304-744-0590</u>
Rep: <u>Allen Marker</u>	<u>Sp. Chas. WV. 25309</u>	TOLL FREE
Email Address: <u>GRMarkerSons@ADL.com</u>		FAX <u>304 746-5203</u>
Company: _____	_____	PHONE _____
Rep: _____	_____	TOLL FREE _____
Email Address: _____	_____	FAX _____
Company: _____	_____	PHONE _____
Rep: _____	_____	TOLL FREE _____
Email Address: _____	_____	FAX _____
Company: _____	_____	PHONE _____
Rep: _____	_____	TOLL FREE _____
Email Address: _____	_____	FAX _____

**BID BOND**

KNOW ALL MEN BY THESE PRESENTS, That we, the undersigned, Garcie R. Marker & Sons, Inc.  
of South Charleston, WV, as Principal, and The Cincinnati Insurance Company  
of Fairfield, OH, a corporation organized and existing under the laws of the State of OH  
with its principal office in the City of Fairfield, as Surety, are held and firmly bound unto the State  
of West Virginia, as Obligee, in the penal sum of Five Percent of Amount Bid (\$ 5%) for the payment of which,  
well and truly to be made, we jointly and severally bind ourselves, our heirs, administrators, executors, successors and assigns.

The Condition of the above obligation is such that whereas the Principal has submitted to the Purchasing Section of the  
Department of Administration a certain bid or proposal, attached hereto and made a part hereof, to enter into a contract in writing for  
Bollard System Installation RFQ No. PRS09021 - According to Plans and Specifications

NOW THEREFORE,

- (a) If said bid shall be rejected, or
- (b) If said bid shall be accepted and the Principal shall enter into a contract in accordance with the bid or proposal attached  
hereto and shall furnish any other bonds and insurance required by the bid or proposal, and shall in all other respects perform the  
agreement created by the acceptance of said bid, then this obligation shall be null and void, otherwise this obligation shall remain in full  
force and effect. It is expressly understood and agreed that the liability of the Surety for any and all claims hereunder shall, in no event,  
exceed the penal amount of this obligation as herein stated.

The Surety, for the value received, hereby stipulates and agrees that the obligations of said Surety and its bond shall be in no  
way impaired or affected by any extension of the time within which the Obligee may accept such bid, and said Surety does hereby  
waive notice of any such extension.

IN WITNESS WHEREOF, Principal and Surety have hereunto set their hands and seals, and such of them as are corporations  
have caused their corporate seals to be affixed hereunto and these presents to be signed by their proper officers, this  
25th day of February, 2009.

Principal Corporate Seal

Garcie R. Marker & Sons, Inc.  
(Name of Principal)

By: Allen Marker  
(Must be President or  
Vice President)

Allen Marker President  
(Title)

Surety Corporate Seal

The Cincinnati Insurance Company  
(Name of Surety)

By: Kimberly J. Wilkinson  
Kimberly J. Wilkinson, WV Resident Agent Attorney-in-Fact

IMPORTANT – Surety executing bonds must be licensed in West Virginia to transact surety insurance. Corporate seals must be affixed,  
and a power of attorney must be attached.

THE CINCINNATI INSURANCE COMPANY

Fairfield, Ohio

POWER OF ATTORNEY

KNOW ALL MEN BY THESE PRESENTS: That THE CINCINNATI INSURANCE COMPANY, a corporation organized under the laws of the State of Ohio, and having its principal office in the City of Fairfield, Ohio, does hereby constitute and appoint

Allan L. McVey; Larry D. Kerr; Gregory T. Gordon; Patricia A. Moye and/or Kimberly J. Wilkinson

of Charleston, West Virginia its true and lawful Attorney(s)-in-Fact to sign, execute, seal and deliver on its behalf as Surety, and as its act and deed, any and all bonds, policies, undertakings, or other like instruments, as follows:

Any such obligations in the United States, up to Twenty Million and No/100 Dollars (\$20,000,000.00).

This appointment is made under and by authority of the following resolution passed by the Board of Directors of said Company at a meeting held in the principal office of the Company, a quorum being present and voting, on the 6th day of December, 1958, which resolution is still in effect:

"RESOLVED, that the President or any Vice President be hereby authorized, and empowered to appoint Attorneys-in-Fact of the Company to execute any and all bonds, policies, undertakings, or other like instruments on behalf of the Corporation, and may authorize any officer or any such Attorney-in-Fact to affix the corporate seal; and may with or without cause modify or revoke any such appointment or authority. Any such writings so executed by such Attorneys-in-Fact shall be binding upon the Company as if they had been duly executed and acknowledged by the regularly elected officers of the Company."

This Power of Attorney is signed and sealed by facsimile under and by the authority of the following Resolution adopted by the Board of Directors of the Company at a meeting duly called and held on the 7th day of December, 1973.

"RESOLVED, that the signature of the President or a Vice President and the seal of the Company may be affixed by facsimile on any power of attorney granted, and the signature of the Secretary or Assistant Secretary and the seal of the Company may be affixed by facsimile to any certificate of any such power and any such power of certificate bearing such facsimile signature and seal shall be valid and binding on the Company. Any such power so executed and sealed and certified by certificate so executed and sealed shall, with respect to any bond or undertaking to which it is attached, continue to be valid and binding on the Company."

IN WITNESS WHEREOF, THE CINCINNATI INSURANCE COMPANY has caused these presents to be sealed with its corporate seal, duly attested by its Vice President this 1st day of April, 2007.



THE CINCINNATI INSURANCE COMPANY

Thomas H. Kelly
Vice President

STATE OF OHIO ) ss:
COUNTY OF BUTLER )

On this 1st day of April, 2007, before me came the above-named Senior Vice President of THE CINCINNATI INSURANCE COMPANY, to me personally known to be the officer described herein, and acknowledged that the seal affixed to the preceding instrument is the corporate seal of said Company and the corporate seal and the signature of the officer were duly affixed and subscribed to said instrument by the authority and direction of said corporation.



Mark J. Huller
MARK J. HULLER, Attorney at Law
NOTARY PUBLIC - STATE OF OHIO

My commission has no expiration date. Section 147.03 O.R.C.

I, the undersigned Secretary or Assistant Secretary of THE CINCINNATI INSURANCE COMPANY, hereby certify that the above is a true and correct copy of the Original Power of Attorney issued by said Company, and do hereby further certify that the said Power of Attorney is still in full force and effect.

GIVEN under my hand and seal of said Company at Fairfield, Ohio.
this 25th day of February 2009



Gregory J. Schlemmer
Secretary



State of West Virginia  
DRUG FREE WORKPLACE CONFORMANCE AFFIDAVIT  
West Virginia Code §21-1D-5

STATE OF WEST VIRGINIA,

COUNTY OF Kanawha, TO-WIT:

I, Allen Marker, after being first duly sworn, depose and state as follows:

- 1. I am an employee of Garcie R. Marker & Sons, Inc.; and,  
(Company Name)
- 2. I do hereby attest that Garcie R. Marker & Sons, Inc.  
(Company Name)

maintains a valid written drug free workplace policy and that such policy is in compliance with **West Virginia Code §21-1D-5**.

The above statements are sworn to under the penalty of perjury.

Garcie R. Marker & Sons, Inc.  
(Company Name)

By: Allen Marker

Title: President

Date: 02/25/09

Taken, subscribed and sworn to before me this 25 day of February 2009.

By Commission expires June 28, 2015

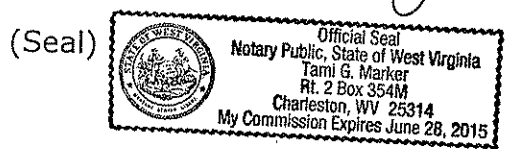

Tami G. Marker  
(Notary Public)

**THIS AFFIDAVIT MUST BE SUBMITTED WITH THE BID IN ORDER TO COMPLY WITH WV CODE PROVISIONS. FAILURE TO INCLUDE THE AFFIDAVIT WITH THE BID SHALL RESULT IN DISQUALIFICATION OF THE BID.**

STATE OF WEST VIRGINIA  
Purchasing Division**PURCHASING AFFIDAVIT****VENDOR OWING A DEBT TO THE STATE:**

**West Virginia Code** §5A-3-10a provides that: No contract or renewal of any contract may be awarded by the state or any of its political subdivisions to any vendor or prospective vendor when the vendor or prospective vendor or a related party to the vendor or prospective vendor is a debtor and the debt owed is an amount greater than one thousand dollars in the aggregate.

**PUBLIC IMPROVEMENT CONTRACTS & DRUG-FREE WORKPLACE ACT:**

If this is a solicitation for a public improvement construction contract, the vendor, by its signature below, affirms that it has a written plan for a drug-free workplace policy in compliance with Article 1D, Chapter 21 of the **West Virginia Code**. The vendor **must** make said affirmation with its bid submission. Further, public improvement construction contract may not be awarded to a vendor who does not have a written plan for a drug-free workplace policy in compliance with Article 1D, Chapter 21 of the **West Virginia Code** and who has not submitted that plan to the appropriate contracting authority in timely fashion. For a vendor who is a subcontractor, compliance with Section 5, Article 1D, Chapter 21 of the **West Virginia Code** may take place before their work on the public improvement is begun.

**ANTITRUST:**

In submitting a bid to any agency for the state of West Virginia, the bidder offers and agrees that if the bid is accepted the bidder will convey, sell, assign or transfer to the state of West Virginia all rights, title and interest in and to all causes of action it may now or hereafter acquire under the antitrust laws of the United States and the state of West Virginia for price fixing and/or unreasonable restraints of trade relating to the particular commodities or services purchased or acquired by the state of West Virginia. Such assignment shall be made and become effective at the time the purchasing agency tenders the initial payment to the bidder.

I certify that this bid is made without prior understanding, agreement, or connection with any corporation, firm, limited liability company, partnership or person or entity submitting a bid for the same materials, supplies, equipment or services and is in all respects fair and without collusion or fraud. I further certify that I am authorized to sign the certification on behalf of the bidder or this bid.

**LICENSING:**

Vendors must be licensed and in good standing in accordance with any and all state and local laws and requirements by any state or local agency of West Virginia, including, but not limited to, the West Virginia Secretary of State's Office, the West Virginia Tax Department, West Virginia Insurance Commission, or any other state agencies or political subdivision. Furthermore, the vendor must provide all necessary releases to obtain information to enable the Director or spending unit to verify that the vendor is licensed and in good standing with the above entities.

**CONFIDENTIALITY:**

The vendor agrees that he or she will not disclose to anyone, directly or indirectly, any such personally identifiable information or other confidential information gained from the agency, unless the individual who is the subject of the information consents to the disclosure in writing or the disclosure is made pursuant to the agency's policies, procedures and rules. Vendor further agrees to comply with the Confidentiality Policies and Information Security Accountability Requirements, set forth in <http://www.state.wv.us/admin/purchase/privacy/noticeConfidentiality.pdf>.

Under penalty of law for false swearing (**West Virginia Code** §61-5-3), it is hereby certified that the vendor affirms and acknowledges the information in this affidavit and is in compliance with the requirements as stated.

Vendor's Name: Garcie R. Marker & Sons, IncAuthorized Signature:  Date: 02/25/09