



State of West Virginia
 Department of Administration
 Purchasing Division
 2019 Washington Street East
 Post Office Box 50130
 Charleston, WV 25305-0130

Request for Quotation

RFQ NUMBER
 GSD096451

PAGE
 1

ADDRESS CORRESPONDENCE TO ATTENTION OF
 KRISTA FERRELL
 304-558-2596

VENDOR

*709053330 304-632-1558
 DANHILL CONSTRUCTION COMPANY
 PO BOX 685
 GAULEY BRIDGE WV 25085

SHIP TO

DEPARTMENT OF ADMINISTRATION
 GENERAL SERVICES DIVISION
 BUILDING TWENTY FOUR
 153 WEST MAIN STREET
 CLARKSBURG WV
 26301 304-558-2317

DATE PRINTED	TERMS OF SALE	SHIP VIA	F.O.B.	FREIGHT TERMS
04/28/2009				

BID OPENING DATE: 05/13/2009 BID OPENING TIME 01:30PM

LINE	QUANTITY	UQP	CAT NO	ITEM NUMBER	UNIT PRICE	AMOUNT
0001	1	JB		968-42		\$215,000 ⁰⁰
ADA COMPLIANT RESTROOM RENOVATIONS, BLDG#84 REQUEST FOR QUOTATION (RFQ) THE WEST VIRGINIA PURCHASING DIVISION FOR THE AGENCY, THE WEST VIRGINIA DIVISION OF GENERAL SERVICES, IS SOLICITING BIDS TO PROVIDE ALL LABOR AND MATERIALS TO PROVIDE ADA COMPLIANT RESTROOM RENOVATIONS FOR BUILDING #84 (CORNERSTONE BUILDING) LOCATED AT 1409 GREENBRIER STREET IN CHARLESTON, WEST VIRGINIA PER THE ATTACHED SPECIFICATIONS. SITE VISITS MAY BE ARRANGED BY CONTACTING LARRY LEROSE, BUILDING MAINTENANCE SUPERVISOR AT 304-982-0531. ALL TECHNICAL QUESTIONS MUST BE SUBMITTED IN ACCORDANCE WITH THE THE PROVISIONS RFQ. TECHNICAL QUESTIONS CONCERNING THIS PROJECT MUST BE SUBMITTED IN WRITING TO KRISTA FERRELL IN THE WEST VIRGINIA STATE PURCHASING DIVISION VIA FAX AT 304-558-4115 OR VIA EMAIL AT KRISTA.S.FERRELL@WV.GOV. DEADLINE FOR ALL TECHNICAL QUESTIONS IS THURSDAY, APRIL 30, 2009 @ THE CLOSE OF BUSINESS. ALL TECHNICAL QUESTIONS RECEIVED, IF ANY, WILL BE ANSWERED BY ADDENDUM AFTER THE DEADLINE HAS LAPSED. QUESTIONS CONCERNING THE ACTUAL PROCESS BY WHICH A VENDOR MAY SUBMIT A BID TO THE STATE OF WEST VIRGINIA ARE NOT CONSIDERED TO BE TECHNICAL QUESTIONS AND MAY						

2009 MAY 19 PM 12:09
 WV PURCHASING DIVISION

SEE REVERSE SIDE FOR TERMS AND CONDITIONS

SIGNATURE: *Robert D. Hill* TELEPHONE: 304-632-1600 DATE: 5-19-09
 TITLE: Pres. FEIN: 55-0648251 ADDRESS CHANGES TO BE NOTED ABOVE

WHEN RESPONDING TO RFQ, INSERT NAME AND ADDRESS IN SPACE ABOVE LABELED 'VENDOR'

**GENERAL TERMS & CONDITIONS
REQUEST FOR QUOTATION (RFQ) AND REQUEST FOR PROPOSAL (RFP)**

1. Awards will be made in the best interest of the State of West Virginia.
2. The State may accept or reject in part, or in whole, any bid.
3. All quotations are governed by the *West Virginia Code* and the *Legislative Rules* of the Purchasing Division.
4. Prior to any award, the apparent successful vendor must be properly registered with the Purchasing Division and have paid the required \$125 fee.
5. All services performed or goods delivered under State Purchase Order/Contracts are to be continued for the term of the Purchase Order/Contracts, contingent upon funds being appropriated by the Legislature or otherwise being made available. In the event funds are not appropriated or otherwise available for these services or goods, this Purchase Order/Contract becomes void and of no effect after June 30.
6. Payment may only be made after the delivery and acceptance of goods or services.
7. Interest may be paid for late payment in accordance with the *West Virginia Code*.
8. Vendor preference will be granted upon written request in accordance with the *West Virginia Code*.
9. The State of West Virginia is exempt from federal and state taxes and will not pay or reimburse such taxes.
10. The Director of Purchasing may cancel any Purchase Order/Contract upon 30 days written notice to the seller.
11. The laws of the State of West Virginia and the *Legislative Rules* of the Purchasing Division shall govern all rights and duties under the Contract, including without limitation the validity of this Purchase Order/Contract.
12. Any reference to automatic renewal is hereby deleted. The Contract may be renewed only upon mutual written agreement of the parties.
13. **BANKRUPTCY:** In the event the vendor/contractor files for bankruptcy protection, this Contract may be deemed null and void, and terminated without further order.
14. **HIPAA BUSINESS ASSOCIATE ADDENDUM:** The West Virginia State Government HIPAA Business Associate Addendum (BAA), approved by the Attorney General, and available online at the Purchasing Division's web site (<http://www.state.wv.us/admin/purchase/vrc/hipaa.htm>) is hereby made part of the agreement. Provided that, the Agency meets the definition of a Cover Entity (45 CFR §160.103) and will be disclosing Protected Health Information (45 CFR §160.103) to the vendor.
15. **WEST VIRGINIA ALCOHOL & DRUG-FREE WORKPLACE ACT:** If this Contract constitutes a public improvement construction contract as set forth in Article 1D, Chapter 21 of the West Virginia Code ("The West Virginia Alcohol and Drug-Free Workplace Act"), then the following language shall hereby become part of this Contract: "The contractor and its subcontractors shall implement and maintain a written drug-free workplace policy in compliance with the West Virginia Alcohol and Drug-Free Workplace Act, as set forth in Article 1D, Chapter 21 of the West Virginia Code. The contractor and its subcontractors shall provide a sworn statement in writing, under the penalties of perjury, that they maintain a valid drug-free work place policy in compliance with the West Virginia and Drug-Free Workplace Act. It is understood and agreed that this Contract shall be cancelled by the awarding authority if the Contractor: 1) Fails to implement its drug-free workplace policy; 2) Fails to provide information regarding implementation of the contractor's drug-free workplace policy at the request of the public authority; or 3) Provides to the public authority false information regarding the contractor's drug-free workplace policy."

INSTRUCTIONS TO BIDDERS

1. Use the quotation forms provided by the Purchasing Division.
2. **SPECIFICATIONS:** Items offered must be in compliance with the specifications. Any deviation from the specifications must be clearly indicated by the bidder. Alternates offered by the bidder as **EQUAL** to the specifications must be clearly defined. A bidder offering an alternate should attach complete specifications and literature to the bid. The Purchasing Division may waive minor deviations to specifications.
3. Complete all sections of the quotation form.
4. Unit prices shall prevail in case of discrepancy.
5. All quotations are considered F.O.B. destination unless alternate shipping terms are clearly identified in the quotation.
6. **BID SUBMISSION:** All quotations must be delivered by the bidder to the office listed below prior to the date and time of the bid opening. Failure of the bidder to deliver the quotations on time will result in bid disqualifications: Department of Administration, Purchasing Division, 2019 Washington Street East, P.O. Box 50130, Charleston, WV 25305-0130



State of West Virginia
 Department of Administration
 Purchasing Division
 2019 Washington Street East
 Post Office Box 50130
 Charleston, WV 25305-0130

Request for Quotation

RFQ NUMBER
 GSD096451

PAGE
 2

ADDRESS CORRESPONDENCE TO ATTENTION OF:
 KRISTA FERRELL
 304-558-2596

VENDOR

*709053330 304-632-1558
 DANHILL CONSTRUCTION COMPANY
 PO BOX 685
 GAULEY BRIDGE WV 25085

SHIP TO

DEPARTMENT OF ADMINISTRATION
 GENERAL SERVICES DIVISION
 BUILDING TWENTY FOUR
 153 WEST MAIN STREET
 CLARKSBURG WV
 26301 304-558-2317

DATE PRINTED	TERMS OF SALE	SHIP VIA	F.O.B.	FREIGHT TERMS
04/28/2009				

BID OPENING DATE: 05/13/2009 BID OPENING TIME 01:30PM

LINE	QUANTITY	UOP	CAT NO.	ITEM NUMBER	UNIT PRICE	AMOUNT
<p>BE SUBMITTED AT ANY TIME PRIOR TO THE BID OPENING AND IN ANY FORMAT.</p> <p>EXHIBIT 5</p> <p>WEST VIRGINIA CODE 21-1D-5 PROVIDES THAT: ANY SOLICITATION FOR A PUBLIC IMPROVEMENT CONSTRUCTION CONTRACT REQUIRES EACH VENDOR THAT SUBMITS A BID FOR THE WORK TO SUBMIT AT THE SAME TIME AN AFFIDAVIT OF COMPLIANCE WITH THE BID. THE ENCLOSED DRUG-FREE WORKPLACE AFFIDAVIT MUST BE SIGNED AND SUBMITTED WITH THE BID AS EVIDENCE OF THE VENDOR'S COMPLIANCE WITH THE PROVISIONS OF ARTICLE 1D, CHAPTER 21 OF THE WEST VIRGINIA CODE. FAILURE TO SUBMIT THE SIGNED DRUG-FREE WORKPLACE AFFIDAVIT WITH THE BID SHALL RESULT IN DISQUALIFICATION OF SUCH BID.</p> <p>NOTICE TO PROCEED: THIS CONTRACT IS TO BE PERFORMED WITHIN 60 CALENDAR DAYS AFTER THE NOTICE TO PROCEED IS RECEIVED. THE AGENCY WILL ISSUE A WRITTEN NOTICE TO PROCEED TO THE SUCCESSFUL VENDOR.</p> <p>CANCELLATION: THE DIRECTOR OF PURCHASING RESERVES THE RIGHT TO CANCEL THIS CONTRACT IMMEDIATELY UPON WRITTEN NOTICE TO THE VENDOR IF THE MATERIALS OR WORKMANSHIP SUPPLIED ARE OF AN INFERIOR QUALITY OR DO NOT CONFORM WITH THE SPECIFICATIONS OF THE BID AND CONTRACT HERE IN.</p> <p>WAGE RATES: THE CONTRACTOR OR SUBCONTRACTOR SHALL PAY THE HIGHER OF THE U.S. DEPARTMENT OF LABOR MINIMUM WAG RATES AS ESTABLISHED FOR KANAWHA COUNTY, PURSUANT TO WEST VIRGINIA CODE 21-5A, ET, SEQ. (PREVAILING WAGE RATES APPLY TO THIS PROJECT)</p> <p>ARBITRATION: ANY REFERENCES MADE TO ARBITRATION OR INTEREST FOR PAYMENTS DUE (EXCEPT FOR ANY INTEREST</p>						

SEE REVERSE SIDE FOR TERMS AND CONDITIONS

SIGNATURE	TELEPHONE	DATE
-----------	-----------	------

TITLE	FEIN	ADDRESS CHANGES TO BE NOTED ABOVE
-------	------	-----------------------------------

WHEN RESPONDING TO RFQ, INSERT NAME AND ADDRESS IN SPACE ABOVE LABELED 'VENDOR'



State of West Virginia
 Department of Administration
 Purchasing Division
 2019 Washington Street East
 Post Office Box 50130
 Charleston, WV 25305-0130

Request for Quotation

RFQ NUMBER
 GSD096451

PAGE
 3

ADDRESS CORRESPONDENCE TO ATTENTION OF:
 KRISTA FERRELL
 304-558-2596

VENDOR

*709053330 304-632-1558
 DANHILL CONSTRUCTION COMPANY
 PO BOX 685
 GAULEY BRIDGE WV 25085

SHIP TO

DEPARTMENT OF ADMINISTRATION
 GENERAL SERVICES DIVISION
 BUILDING TWENTY FOUR
 153 WEST MAIN STREET
 CLARKSBURG WV
 26301 304-558-2317

DATE PRINTED	TERMS OF SALE	SHIP VIA	F.O.B	FREIGHT TERMS
04/28/2009				

BID OPENING DATE: 05/13/2009 BID OPENING TIME 01:30PM

LINE	QUANTITY	UOP	CAT. NO.	ITEM NUMBER	UNIT PRICE	AMOUNT
<p>REQUIRED BY STATE LAW) CONTAINED IN THIS CONTRACT OR IN ANY AMERICAN INSTITUTE OF ARCHITECTS DOCUMENTS PERTAINING TO THIS CONTRACT ARE HEREBY DELETED.</p> <p>WORKERS' COMPENSATION: VENDOR IS REQUIRED TO PROVIDE A CERTIFICATE FROM WORKERS' COMPENSATION IF SUCCESSFUL FOR THE LIFE OF THE CONTRACT.</p> <p>ALL OF THE ITEMS CHECKED BELOW WILL BE A REQUIREMENT OF THIS CONTRACT:</p> <p>(XX) INSURANCE: SUCCESSFUL VENDOR SHALL FURNISH PROOF OF COMMERCIAL GENERAL LIABILITY INSURANCE PRIOR TO ISSUANCE OF CONTRACT. UNLESS OTHERWISE SPECIFIED IN THE BID DOCUMENTS, THE MINIMUM AMOUNT OF INSURANCE COVERAGE REQUIRED IS \$1,000,000.00.</p> <p>() BUILDERS RISK INSURANCE: SUCCESSFUL VENDOR SHALL FURNISH PROOF OF BUILDERS RISK - ALL RISK INSURANCE IN AN AMOUNT EQUAL TO 100% OF THE AMOUNT OF THE CONTRACT.</p> <p>(XX) BONDS: FIVE PERCENT (5%) OF THE TOTAL AMOUNT OF THE BID PAYABLE TO THE STATE OF WEST VIRGINIA, SHALL BE SUBMITTED WITH EACH BID AS A BID BOND. THE SUCCESSFUL BIDDER SHALL ALSO FURNISH A PERFORMANCE BOND AND LABOR/MATERIAL BOND FOR 100% OF THE AMOUNT OF THE CONTRACT. BONDS MAY BE PROVIDED IN THE FORM OF A CERTIFIED CHECK, IRREVOCABLE LETTER OF CREDIT, OR BOND FURNISHED BY A SOLVENT SURETY COMPANY AUTHORIZED TO DO BUSINESS IN THE STATE OF WEST VIRGINIA. A LETTER OF CREDIT SUBMITTED IN LIEU OF A BOND WILL ONLY BE ALLOWED FOR PROJECTS UNDER \$100,000. PERSONAL OR BUSINESS CHECKS ARE NOT ACCEPCTABLE IN LIEU OF THE 5% BID BOND, PERFORMANCE BOND, OR LABOR AND MATERIAL BOND.</p> <p>() MAINTENANCE BOND: A TWO (2) YEAR MAINTENANCE BON</p>						

SEE REVERSE SIDE FOR TERMS AND CONDITIONS

SIGNATURE	TELEPHONE	DATE
TITLE	FEIN	ADDRESS CHANGES TO BE NOTED ABOVE

WHEN RESPONDING TO RFQ, INSERT NAME AND ADDRESS IN SPACE ABOVE LABELED 'VENDOR'



State of West Virginia
 Department of Administration
 Purchasing Division
 2019 Washington Street East
 Post Office Box 50130
 Charleston, WV 25305-0130

Request for Quotation

RFQ NUMBER
 GSD096451

PAGE
 4

ADDRESS CORRESPONDENCE TO ATTENTION OF:
 KRISTA FERRELL
 304-558-2596

VENDOR

*709053330 304-632-1558
 DANHILL CONSTRUCTION COMPANY
 PO BOX 685
 GAULEY BRIDGE WV 25085

SHIP TO

DEPARTMENT OF ADMINISTRATION
 GENERAL SERVICES DIVISION
 BUILDING TWENTY FOUR
 153 WEST MAIN STREET
 CLARKSBURG WV
 26301 304-558-2317

DATE PRINTED	TERMS OF SALE	SHIP VIA	F.O.B.	FREIGHT TERMS
04/28/2009				

BID OPENING DATE: 05/13/2009 BID OPENING TIME 01:30PM

LINE	QUANTITY	UOP	CAT NO	ITEM NUMBER	UNIT PRICE	AMOUNT
				COVERING THE ROOFING SYSTEM WILL BE A REQUIREMENT OF THE SUCCESSFUL VENDOR. REV. 11/00 EXHIBIT 7 DOMESTIC ALUMINUM, GLASS & STEEL IN PUBLIC WORKS PROJECTS IN ACCORDANCE WITH WEST VIRGINIA CODE 5-19-1 ET., SEQ., EVERY CONTRACT FOR CONSTRUCTION, RECONSTRUCTION, ALTERATION, REPAIR, IMPROVEMENT OR MAINTENANCE OF PUBLIC WORKS, WHERE THE COST IS MORE THAN \$50,000 AND, IN THE CASE OF STEEL ONLY, WHERE THE COST OF STEEL IS MORE THAN \$50,000 OR WHERE MORE THAN 10,000 POUNDS OF STEEL ARE REQUIRED, THE STATE WILL ACCEPT ONLY ALUMINUM GLASS, OR STEEL PRODUCTS PRODUCED IN THE UNITED STATES. IN ADDITION, ITEMS OF MACHINERY OR EQUIPMENT PURCHASED FOR USE AT THE SITE OF PUBLIC WORKS SHALL BE MADE OF DOMESTIC ALUMINUM, GLASS OR STEEL, UNLESS THE COST OF THE PRODUCT IS LESS THAN \$50,000 OR LESS THAN 10,000 POUNDS OF STEEL ARE USED IN PUBLIC WORKS PROJECTS. FOREIGN MADE ALUMINUM, GLASS OR STEEL PRODUCTS MAY BE ACCEPTED ONLY IF THE COST OF DOMESTIC PRODUCTS IS FOUND TO BE UNREASONABLE. SUCH COST IS UNREASONABLE IF IT IS 20% OR MORE HIGHER THAN THE BID PRICE FOR FOREIGN MADE PRODUCTS. IF THE DOMESTIC ALUMINUM, GLASS OR STEEL PRODUCTS TO BE SUPPLIED OR PRODUCED IN A "SUBSTANTIAL LABOR SURPLUS AREA", AS DEFINED BY THE UNITED STATES DEPARTMENT OF LABOR, FOREIGN PRODUCTS MAY BE SUPPLIED ONLY IF DOMESTIC PRODUCTS ARE 30% OR MORE HIGHER IN PRICE THAN THE FOREIGN MADE PRODUCTS.		

SEE REVERSE SIDE FOR TERMS AND CONDITIONS

SIGNATURE _____ TELEPHONE _____ DATE _____

TITLE _____ FEIN _____ ADDRESS CHANGES TO BE NOTED ABOVE

WHEN RESPONDING TO RFQ, INSERT NAME AND ADDRESS IN SPACE ABOVE LABELED 'VENDOR'



State of West Virginia
 Department of Administration
 Purchasing Division
 2019 Washington Street East
 Post Office Box 50130
 Charleston, WV 25305-0130

Request for Quotation

RFQ NUMBER
 GSD096451

PAGE
 5

ADDRESS CORRESPONDENCE TO ATTENTION OF
 KRISTA FERRELL
 304-558-2596

*709053330 304-632-1558
 DANHILL CONSTRUCTION COMPANY
 PO BOX 685
 GAULEY BRIDGE WV 25085

DEPARTMENT OF ADMINISTRATION
 GENERAL SERVICES DIVISION
 BUILDING TWENTY FOUR
 153 WEST MAIN STREET
 CLARKSBURG WV
 26301 304-558-2317

DATE PRINTED	TERMS OF SALE	SHIP VIA	F.O.B	FREIGHT TERMS
04/28/2009				

BID OPENING DATE: 05/13/2009 BID OPENING TIME 01:30PM

LINE	QUANTITY	UOP	CAT NO.	ITEM NUMBER	UNIT PRICE	AMOUNT
<p>IF, PRIOR TO THE AWARD OF A CONTRACT UNDER THE ABOVE PROVISIONS, THE SPENDING OFFICER OF THE SPENDING UNIT DETERMINES THAT THERE EXISTS A BID FOR LIKE FOREIGN ALUMINUM, GLASS OR STEEL THAT IS REASONABLE AND LOWER THAN THE LOWEST BID DOMESTIC PRODUCTS, THE SPENDING OFFICE MAY REQUEST, IN WRITING, A REEVALUATION AND REDUCTION IN THE LOWEST BID FOR SUCH DOMESTIC PRODUCTS. ALL VENDORS MUST INDICATE IN THEIR BID IF THEY ARE SUPPLYING FOREIGN ALUMINUM, GLASS OR STEEL.</p> <p>REV. 3/88</p> <p>EXHIBIT 9</p> <p>NOTICE FOR ISSUANCE & ACKNOWLEDGEMENT OF CONSTRUCTION PROJECT ADDENDA</p> <p>THE ARCHITECT/ENGINEER AND/OR AGENCY SHALL BE REQUIRED TO ABIDE BY THE FOLLOWING SCHEDULE IN ISSUING CONSTRUCTION PROJECT ADDENDA FOR STATE AGENCIES:</p> <p>(1) THE ARCHITECT/ENGINEER SHALL PREPARE THE ADDENDUM AND A LIST OF ALL PARTIES THAT HAVE PROCURED DRAWINGS AND SPECIFICATIONS FOR THE PROJECT. THE ADDENDUM AND LIST SHALL BE FORWARDED TO THE BUYER IN THE STATE PURCHASING DIVISION. THE ARCHITECT/ENGINEER SHALL ALSO SEND A COPY OF THE ADDENDUM TO THE STATE AGENCY FOR WHICH THE CONTRACT IS ISSUED.</p> <p>(2) THE BUYER SHALL SEND THE ADDENDUM TO ALL INTERESTED PARTIES AND, IF NECESSARY, EXTEND THE BID OPENING DATE. ANY ADDENDUM SHOULD BE RECEIVED BY THE BUYER WITHIN FOURTEEN (14) DAYS PRIOR TO THE BID OPENING DATE.</p>						

SEE REVERSE SIDE FOR TERMS AND CONDITIONS

SIGNATURE	TELEPHONE	DATE
TITLE	FEIN	ADDRESS CHANGES TO BE NOTED ABOVE

WHEN RESPONDING TO RFQ, INSERT NAME AND ADDRESS IN SPACE ABOVE LABELED 'VENDOR'



State of West Virginia
 Department of Administration
 Purchasing Division
 2019 Washington Street East
 Post Office Box 50130
 Charleston, WV 25305-0130

Request for Quotation

RFQ NUMBER
 GSD096451

PAGE
 6

ADDRESS CORRESPONDENCE TO ATTENTION OF:
 KRISTA FERRELL
 304-558-2596

VENDOR
 *709053330 304-632-1558
 DANHILL CONSTRUCTION COMPANY
 PO BOX 685
 GAULEY BRIDGE WV 25085

SHIP TO
 DEPARTMENT OF ADMINISTRATION
 GENERAL SERVICES DIVISION
 BUILDING TWENTY FOUR
 153 WEST MAIN STREET
 CLARKSBURG WV
 26301 304-558-2317

DATE PRINTED	TERMS OF SALE	SHIP VIA	F.O.B.	FREIGHT TERMS
04/28/2009				

BID OPENING DATE: 05/13/2009 BID OPENING TIME 01:30PM

LINE	QUANTITY	UOP	CAT NO.	ITEM NUMBER	UNIT PRICE	AMOUNT
<p>(3) ALL ADDENDA SHOULD BE FORMALLY ACKNOWLEDGED BY ALL BIDDERS AND SUBMITTED TO THE STATE PURCHASING DIVISION. THE SAME RULES AND REGULATIONS THAT APPLY TO THE ORIGINAL BIDDING DOCUMENT SHALL ALSO APPLY TO AN ADDENDUM DOCUMENT. THE ONLY EXCEPTION MAY BE FOR AN ADDENDUM THAT IS ISSUED FOR THE SOLE PURPOSE OF CHANGING A BID OPENING TIME AND/OR DATE.</p> <p>REV. 11/96</p> <p>EXHIBIT 10</p> <p>ADDENDUM ACKNOWLEDGEMENT</p> <p>I HEREBY ACKNOWLEDGE RECEIPT OF THE FOLLOWING CHECKED ADDENDUM(S) AND HAVE MADE THE NECESSARY REVISIONS TO MY PROPOSAL, PLANS AND/OR SPECIFICATION, ETC.</p> <p>ADDENDUM NOS. :</p> <p>NO. 1 . 5-8-09.....</p> <p>NO. 2 </p> <p>NO. 3 </p> <p>NO. 4 </p> <p>NO. 5 </p> <p>I UNDERSTAND THAT FAILURE TO CONFIRM THE RECEIPT OF THE ADDENDUM(S) MAY BE CAUSE FOR REJECTION OF THE BIDS.</p> <p>VENDOR MUST CLEARLY UNDERSTAND THAT ANY VERBAL</p>						

SEE REVERSE SIDE FOR TERMS AND CONDITIONS

SIGNATURE <i>Robert D. Hill</i>	TELEPHONE 304-632-1600	DATE 5-19-09
TITLE Pres.	FEIN 55-0648251	ADDRESS CHANGES TO BE NOTED ABOVE

WHEN RESPONDING TO RFQ, INSERT NAME AND ADDRESS IN SPACE ABOVE LABELED 'VENDOR'



State of West Virginia
 Department of Administration
 Purchasing Division
 2019 Washington Street East
 Post Office Box 50130
 Charleston, WV 25305-0130

Request for Quotation

RFQ NUMBER
GSD096451

PAGE
7

ADDRESS CORRESPONDENCE TO ATTENTION OF
KRISTA FERRELL 304-558-2596

*709053330 304-632-1558
 DANHILL CONSTRUCTION COMPANY
 PO BOX 685
 GAULEY BRIDGE WV 25085

DEPARTMENT OF ADMINISTRATION
 GENERAL SERVICES DIVISION
 BUILDING TWENTY FOUR
 153 WEST MAIN STREET
 CLARKSBURG WV
 26301 304-558-2317

DATE PRINTED	TERMS OF SALE	SHIP VIA	F.O.B.	FREIGHT TERMS
04/28/2009				

BID OPENING DATE: 05/13/2009 BID OPENING TIME 01:30PM

LINE	QUANTITY	UOP	CAT NO	ITEM NUMBER	UNIT PRICE	AMOUNT
<p>REPRESENTATION MADE OR ASSUMED TO BE MADE DURING ANY ORAL DISCUSSION HELD BETWEEN VENDOR'S REPRESENTATIVES AND ANY STATE PERSONNEL IS NOT BINDING. ONLY THE INFORMATION ISSUED IN WRITING AND ADDED TO THE SPECIFICATIONS BY AN OFFICIAL ADDENDUM IS BINDING.</p> <p><i>Robert D. Hill</i> SIGNATURE <i>Danhill Const. Co.</i> COMPANY <i>5-19-09</i> DATE</p> <p>REV. 11/96</p> <p>CONTRACTORS LICENSE</p> <p>WEST VIRGINIA STATE CODE 21-11-2 REQUIRES THAT ALL PERSONS DESIRING TO PERFORM CONTRACTING WORK IN THIS STATE MUST BE LICENSED. THE WEST VIRGINIA CONTRACTORS LICENSING BOARD IS EMPOWERED TO ISSUE THE CONTRACTORS LICENSE. APPLICATIONS FOR A CONTRACTORS LICENSE MAY BE MADE BY CONTACTING THE WEST VIRGINIA DIVISION OF LABOR CAPITOL COMPLEX, BUILDING 3, ROOM 319, CHARLESTON, WV 25305. TELEPHONE: (304) 558-7890.</p> <p>WEST VIRGINIA STATE CODE 21-11-11 REQUIRES ANY PROSPECTIVE BIDDER TO INCLUDE THE CONTRACTORS LICENSE NUMBER ON THEIR BID.</p> <p>BIDDER TO COMPLETE:</p> <p>CONTRACTORS NAME: <i>Danhill Construction Co.</i> CONTRACTORS LICENSE NO: <i>WV 001196</i></p>						

SEE REVERSE SIDE FOR TERMS AND CONDITIONS		
SIGNATURE	TELEPHONE	DATE
TITLE	FEIN	ADDRESS CHANGES TO BE NOTED ABOVE

WHEN RESPONDING TO RFQ, INSERT NAME AND ADDRESS IN SPACE ABOVE LABELED 'VENDOR'



State of West Virginia
 Department of Administration
 Purchasing Division
 2019 Washington Street East
 Post Office Box 50130
 Charleston, WV 25305-0130

Request for Quotation

RFQ NUMBER
 GSD096451

PAGE
 8

ADDRESS CORRESPONDENCE TO ATTENTION OF
 KRISTA FERRELL
 304-558-2596

*709053330 304-632-1558
 DANHILL CONSTRUCTION COMPANY
 PO BOX 685
 GAULEY BRIDGE WV 25085

DEPARTMENT OF ADMINISTRATION
 GENERAL SERVICES DIVISION
 BUILDING TWENTY FOUR
 153 WEST MAIN STREET
 CLARKSBURG WV
 26301 304-558-2317

DATE PRINTED	TERMS OF SALE	SHIP VIA	F.O.B	FREIGHT TERMS
04/28/2009				

BID OPENING DATE: 05/13/2009 BID OPENING TIME 01:30PM

LINE	QUANTITY	UOP	CAT NO.	ITEM NUMBER	UNIT PRICE	AMOUNT
<p>THE SUCCESSFUL BIDDER WILL BE REQUIRED TO FURNISH A COPY OF THEIR CONTRACTORS LICENSE PRIOR TO ISSUANCE OF A PURCHASE ORDER/CONTRACT</p> <p>APPLICABLE LAW</p> <p>THE WEST VIRGINIA STATE CODE, PURCHASING DIVISION RULES AND REGULATIONS, AND THE INFORMATION PROVIDED IN THE "REQUEST FOR QUOTATION" ISSUED BY THE PURCHASING DIVISION IS THE SOLE AUTHORITY GOVERNING THIS PROCUREMENT.</p> <p>ANY INFORMATION PROVIDED IN SPECIFICATION MANUALS, OR ANY OTHER SOURCE, VERBAL OR WRITTEN, WHICH CONTRADICTS OR ALTERS THE INFORMATION PROVIDED FROM THE SOURCES AS DESCRIBED IN THE ABOVE PARAGRAPH IS VOID AND OF NO EFFECT.</p> <p>BANKRUPTCY: IN THE EVENT THE VENDOR/CONTRACTOR FILES FOR BANKRUPTCY PROTECTION, THIS CONTRACT IS AUTOMATICALLY NULL AND VOID, AND IS TERMINATED WITHOUT FURTHER ORDER.</p> <p>REV. 1/2005</p> <p>NOTICE</p> <p>A SIGNED BID MUST BE SUBMITTED TO:</p> <p>DEPARTMENT OF ADMINISTRATION PURCHASING DIVISION BUILDING 15 2019 WASHINGTON STREET, EAST CHARLESTON, WV 25305-0130</p>						

SEE REVERSE SIDE FOR TERMS AND CONDITIONS

SIGNATURE	TELEPHONE	DATE
TITLE	FEIN	ADDRESS CHANGES TO BE NOTED ABOVE

WHEN RESPONDING TO RFQ, INSERT NAME AND ADDRESS IN SPACE ABOVE LABELED 'VENDOR'



State of West Virginia
 Department of Administration
 Purchasing Division
 2019 Washington Street East
 Post Office Box 50130
 Charleston, WV 25305-0130

Request for Quotation

RFQ NUMBER
GSD096451

PAGE
9

ADDRESS CORRESPONDENCE TO ATTENTION OF
KRISTA FERRELL 304-558-2596

VENDOR

*709053330 304-632-1558
 DANHILL CONSTRUCTION COMPANY
 PO BOX 685
 GAULEY BRIDGE WV 25085

SHIP TO

DEPARTMENT OF ADMINISTRATION
 GENERAL SERVICES DIVISION
 BUILDING TWENTY FOUR
 153 WEST MAIN STREET
 CLARKSBURG WV
 26301 304-558-2317

DATE PRINTED	TERMS OF SALE	SHIP VIA	F.O.B.	FREIGHT TERMS
04/28/2009				

BID OPENING DATE: 05/13/2009 BID OPENING TIME 01:30PM

LINE	QUANTITY	UOP	CAT NO	ITEM NUMBER	UNIT PRICE	AMOUNT
<p>THE BID SHOULD CONTAIN THIS INFORMATION ON THE FACE OF THE ENVELOPE OR THE BID MAY NOT BE CONSIDERED:</p> <p>SEALED BID</p> <p>BUYER: KRISTA FERRELL-FILE 21</p> <p>REQ. NO.: GSD096451</p> <p>BID OPENING DATE: 05/13/2009</p> <p>BID OPENING TIME: 1:30 PM</p> <p>PLEASE PROVIDE A FAX NUMBER IN CASE IT IS NECESSARY TO CONTACT YOU REGARDING YOUR BID: ----- 304-632-1501 -----</p> <p>PLEASE PRINT OR TYPE NAME OF PERSON TO CONTACT CONCERNING THIS QUOTE: ----- Dan Hill -----</p> <p>***** THIS IS THE END OF RFQ GSD096451 ***** TOTAL: \$215,000.00</p>						

SEE REVERSE SIDE FOR TERMS AND CONDITIONS

SIGNATURE	TELEPHONE	DATE
<i>Robert D. Hill</i>	304-632-1600	5-19-09
TITLE	FEIN	ADDRESS CHANGES TO BE NOTED ABOVE
<i>Pres</i>	55-0648251	

WHEN RESPONDING TO RFQ, INSERT NAME AND ADDRESS IN SPACE ABOVE LABELED 'VENDOR'

**REQUEST FOR QUOTATIONS #GSD096451
ADA COMPLIANCE
CORNERSTONE OFFICE BUILDING #84
1409 GREENBRIER STREET
CHARLESTON, WEST VIRGINIA**

Location: West Virginia State Capitol
Cornerstone Office Building #84
1409 Greenbrier Street
Charleston, WV 25305

For: State of West Virginia
General Services Division
1900 Kanawha Boulevard, East
Building 1 Room MB-60
Charleston, WV 25305

All inquiries for specification clarification shall be addressed, by either e-mail or fax, to:

Krista Ferrell, Senior Buyer
Purchasing Division
P.O. Box 50130
Charleston, WV 25305-0130
Fax: (304) 558-4115
Krista.S.Ferrell@wv.gov
Phone: (304) 558-2596

The Acquisition and Contract Administration Section of the Purchasing Division "State" for the West Virginia General Services Division is soliciting quotations to provide modifications to Building 84, Cornerstone Office Building, for conformity with ADA Standards for Accessible Design 28 CFR Part 36, Revised as of July 1, 1994. The building currently falls within the city limits of the City of Charleston, West Virginia.

Site Visitation:

Visits to the jobsite can be arranged by contacting Larry LeRose, Building Maintenance Supervisor, at (304)982-0531. Adequate time must be given to coordinate scheduling of the site visit, as the building is located off of the State Capitol Complex.

Scope:

Contractor will furnish all materials, labor, and equipment necessary to complete all work for the modifications following standards set forth in the ADA Standards for Accessible Design 28 CFR Part 36, Revised as of July 1, 1994. The work consists of the construction of three ADA compliant Women's Restrooms, three ADA compliant Men's Restrooms, removal of existing floor and wall finishes, partition and fixture removal, replacement of drywall, priming and finish painting of drywall, installation of new ADA compliant stainless steel toilet partitions, grab bars, other fixtures, reroute of plumbing lines and drains, removal of flooring and walls, and installation of new floors. The first floor of the building is not above a basement or crawlspace. Existing walls are or metal stud and drywall fabrication. If not pre-existing, walls and ceilings are to be sound insulated. Successful contractor is to remove and install new all ceramic on walls and floors of restrooms. All plumbing to the point of connection to the existing supply system will comply with all applicable plumbing codes and be ADA compliant. Successful contract will use existing floor drains with traps in each restroom. Copper piping in walls and ceilings is to be insulated. Waste lines shall be PVC. All electrical work will comply with all applicable electrical codes and be ADA compliant; successful contractor will replace existing 110V receptacles and install to Code. New exhaust fans are required in each restroom. Successful contractor will replace ceiling tile and install new grid. Replaced ceiling tiles must match existing ceiling tiles. ADA Compliant lights over the mirrors are required, as are water coolers (ADA-compliant) on the 2nd and 3rd Floors. Owner will purchase and install new toilet accessories, other than those specifically called for herein (ie, grab bars, etc). Doors and door frames are to be painted; successful contractor is to provide paint matching the color, texture and finish of that specified herein. All general construction and finish work will comply with standards as set forth in the construction industry and be ADA compliant. All elements of the work is to conform to ADA Standards for Accessible Design 28 CFR Part 36, Revised as of July 1, 1994. Contractor will have general knowledge of the contents of the ADA Standards for Accessible Design 28 CFR Part 36, Revised as of July 1, 1994. Successful contractor shall submit 3 copies of floor plans for placement of ADA items for approval by GSD Engineering Section ten (10) days priors to commencement of any work being performed. Floor plans are to be to scale, on 11" x 17" paper. All measurements must be field verified by bidder. ADA project dimensions are stated and are to be referenced as shown on project drawings ADAW1 and ADAM1. These drawings must be field verified for accuracy.

This Request For Quotations also incorporates project specific documents:

1. General Description of Work (Scope)

2. Drawings 1M, 1W, 2M, 2W, 3M, 3W.
3. ADA Material Specifications
4. Bid Form (Bid Form)
5. ADA Standards for Accessible Design 28 CFR Part 36, Revised as of July 1, 1994

II. DEFINITIONS

- A. The Department of Administration, General Services Division, Room MB-60, State Capitol, Charleston, WV 25305, will hereinafter be called the "Owner".
- B. The service organization on the specifications will hereinafter be called the "Contractor".
- C. "The Contract", as herein stated, will mean the agreement between the Owner and the Contractor to provide the services herein specified.
- D. "Owner's Representative or Designee", as herein stated, shall be defined as that person so designated by the Director of the General Services Division.
- E. "Architect/Engineer", if stated in the Contract shall refer to the General Services Division.

III. GENERAL SPECIFICATIONS

1. All work will be performed in compliance with all applicable safety regulations. Subject to verification and inspection by GSD safety representatives. Contractor is responsible for field verification of measurements.
2. Work schedules must be reviewed, coordinated and approved by GSD. Contractor will be afforded access as required to complete work on schedule. It is required that the project proceed so that restroom facilities are available for the tenants at all times during the project. It is strongly preferred that the 2nd and 3rd floor renovations occur simultaneously first, with the 1st floor being the final area of the project sequence.
3. Scheduled work may not begin until successful vendor has received a signed purchase order and notice to proceed letter.
4. Any areas identified requiring asbestos abatement will be completed by GSD under a separate abatement/ re-insulation contract. If asbestos is uncovered, and a delay to the project occurs to accommodate abatement by the Owner's contractor, the successful contractor may submit a change order request for an extension of time to match the actual delay for the abatement.
5. Two copies (one original and one copy) of invoices will be submitted for payment (in arrears) and must include the following information:

- a. One of the invoices must be in original type or state "original" on the face if computer generated. Invoice must include FEIN number, complete address of vendor and purchase order number of the contract.

General Services Division
1900 Kanawha Blvd. E.
Building 1, Room MB-60
Charleston, WV 25305
Attn: Business Manager

6. The qualified Contractor will perform work for modifications to comply with Accessible Design 28 CFR Part 36, Revised as of July 1, 1994. Authorization to perform the work described herein must be approved in writing and signed by the Owners Representative or Designee.
7. The successful bidder will perform the work described herein and be responsible for all necessary permits, fees and related items to fulfill the contract.
8. The relationship of the Contractor to the Owner shall be that of an independent contractor and no principal-agent relationship or employer-employee relationship is contemplated or created by the parties to this Contract. The Contractor as an independent contractor is solely liable for the acts and omissions of its employees and agents. The Contractor will be responsible for selecting, supervising, and compensating any and all individuals employed pursuant to the terms of this contract. Neither the Contractor nor any employees or sub-contractors of the Contractor will be deemed to be employees for the State for any purposes whatsoever. The wages and salaries, taxes, withholding payments, penalties, fees, fringe benefits, professional liability insurance premiums, contributions to insurance and pension or other deferred obligations, and licensing fees, etc., and the filing of all necessary documents, forms and returns pertinent to all of the foregoing are the Contractor's responsibility. The Contractor will hold harmless the State, and must provide the State and Agency with a defense against any and all claims including but not limited to the foregoing payments, withholdings, contributions, taxes, social security taxes and employer income tax returns. The Contractor will not assign, convey, transfer, sub-contract, or delegate any of its responsibilities and obligations under this contract to any person, corporation, partnership, association or entity without expressed written consent of the Agency.
9. Indemnification: The Contractor agrees to indemnify, defend, and hold harmless the State and the Owner, their officers, and employees from and against (1) Any claims or losses for services rendered by any

subcontractor, person or firm performing or supplying services, materials, or supplies in connection with the performance of the Contract; (2) Any claims or losses resulting to any person or entity injured or damaged by the Contractor, its officers, employees, or subcontractors by the publication, translation, reproduction, delivery, performance, use, or disposition of any data used under the Contract in a manner not authorized by the Contract, or by Federal or State statutes or regulations; (3) Any failure of the Contractor, its officers, employees or sub-contractors to observe State and Federal laws, including but not limited to labor and wage laws.

10. This contract will be governed by the laws of the State of West Virginia. The Contractor further agrees to comply with the Civil Rights Act of 1964 and all other applicable Federal, State, and local Government regulations.

11. The Contractor will procure all necessary permits and licenses to comply with all applicable laws, Federal, State, or municipal, along with all regulations, and ordinances of any regulating body.

12. The Contractor will pay any applicable sales, use, or personal property taxes arising out of this contract and the transactions contemplated thereby. Any other taxes levied upon this Contract, the transaction, or the equipment, or services delivered pursuant hereto shall be borne by the Contractor. It is clearly understood that the State of West Virginia is exempt from any taxes regarding performance of the scope of work of this Contract.

13. Contractor will be responsible for parts and materials as follows:

A. The Contractor will supply all tools, tool accessories, personal safety equipment, and supplies necessary to execute the responsibilities of this Contract. Contractor will be responsible for the removal of all waste and debris as a result of performing this contract on a daily basis. All salvageable items (fixtures, partitions, mirrors, vanities, toilets accessories, etc.) must be placed on pallets in a location designated by Owner for removal by the WV State Agency for Surplus Property.

1) Contractor will be responsible for all mileage and travel costs, including travel time, associated with the performance of this contract.

2) By submittal of your bid you will include a warranty for a minimum of one (1) year for labor and the minimum manufacturer's warranty for materials.

- 3) Contractor will have 60 days to complete the work described in this contract.

14. Contractor will provide for all insurance necessary to render Agency free and harmless from all claims arising from services performed under this agreement. Contract insurance, liability, and compensation insurance must be sufficient to cover the contractor's employees and the public in general. The minimum amount of commercial general liability insurance coverage required is \$1,000,000.00, and a copy of contractor certificate of insurance is required prior to issuance of purchase order for this agreement.

15. All areas of asbestos have either been identified, marked or previously removed. Should the contractor encounter any unidentified, unabated areas, they are to contact the GSD asbestos abatement coordinator, Jon Trout, as soon as possible. (304) 558-2317.

MATERIAL SPECIFICATIONS

It is strongly preferred that bidders wishing to submit based upon products in substitution of those listed herein provide documentation, with their bid, which substantiates that the substitute materials meet the minimum specifications as prescribed herein.

PAINT

Pittsburgh Paint, Dover White, egg shell finish (2 coats), (or equal in color and texture) plus 1 primer coat on walls.

OTHER

Owner will furnish cove base, paint door framing, install toilet paper holders, towel and soap dispensers, mirrors and door signage.

FLOOR TILE, CERAMIC 12"x12"

Mohawk-Melrose, color: cashew (or equal in color and texture); Grout Color: MAPEI #02 Pewter (or equal in color and texture); must be laid with thin-set which is white in color. Furnish and install 3" x 12" bull nose trim (Part Number #AD3787, or equal in color and texture) on walls, align grout lines with floor orientation, and grout in color to match floor tiles.

ADA Material Specifications

FAUCETS

Lavatory Faucets will be DELTA HDF 596- LGHGMHDF, Chrome

OR EQUAL: ADA and ASME A112 Compliant

All fixture supply lines will be stainless steel braided with cutoff valves (chrome) per line, waste lines will be chrome HD Grade, Water supply lines will be copper to the valve (no plastic or PVC) installed to Best Industry Practices and Local Building Code guidelines.

LAVATORY

Crane model DIANA 110 (OR EQUAL): wall hung, white, 25" W x 21-1/4" D (front to back) minimum; Basin of 20- 1/8" W x 14 1/8" D (front to back) minimum, conforms to ANSI/ASME A112 standard:

(Installed RIM height must not exceed 34" to be ADA Compliant)

TOILET

Crane Econo Miser One Big Foot # 31888 (or equal): elongated front, relaxed height 12", white, tankless, with auto-flush valves, complete with matching seat & lids, supply lines furnished (stainless steel braided with shut off valves (chrome).

PARTITIONS

MEDGUARD (or equal), overhead braced, floor mounted Stainless Steel stall partition assemblies, 22 gauge type 304 Stainless Steel, 1" thick, panels not less than 58" height, ALL hardware will be Chromium plated ZAMAC to resist corrosion and through bolted with vandal resistant barrel nuts and shoulder screws.

(2) Handicap stall(s) will utilize 36" doors

(1) Men's stall will utilize 24" door

URINALS

Use existing fixture with adjustments to location to comply with 4.18.1 complete with auto flush valves and new chrome plumbing lines.

AUTO VALVES

ZURN, model ZERK-CPM battery-operated auto-flush valves (or equal)

GENERAL SERVICES DIVISION

**ADA Compliant Restrooms
West Virginia State Office Building
Building 84 – 1409 Greenbrier Street
Charleston, West Virginia**

BID FORM

Danhill Construction Company
NAME OF BIDDER

PO Box 685, Gauley Bridge, WV 25085
ADDRESS OF BIDDER

304-632-1600
PHONE NUMBER

WV 001196
WV CONTRACTOR'S LICENSE NO.

We, the undersigned, having examined the site and being familiar with the local conditions affecting the cost of the work and also being familiar with the general conditions to bidders, drawings, and specifications, hereby propose to furnish all materials, equipment, and labor to complete all work in a workmanlike manner, as described in the Bidding Documents.

TOTAL CONTRACT BID

(\$ 215,000.00)

Two Hundred Fifteen Thousand Dollars

(Total to be written in figures and words.)

The Bidder understands that to the extent allowed by the West Virginia Code, the OWNER reserves the right to waive any informality or irregularity in any Bid, or Bids, and to reject any or all Bids in whole or in part; to reject a bid not accompanied by the required bid security or by other data required by the

Bidding Documents; to reject any conditions of the bid by the Bidder that is in any way inconsistent with the requirements, terms, and conditions of the Bidding Documents; or to reject a bid that is in any way incomplete or irregular.

The Bidder, if successful and awarded the contract, agrees that all work is to be complete within Sixty (60) consecutive calendar days following receipt of the OWNER'S written notice to proceed. For each calendar day of delay in achieving completion, the Contractor shall be liable for, and shall pay the OWNER liquidated damages in the amount of \$100.00 per day.

Any work performed or any materials contracted for prior to the receipt of the OWNER'S written notice to proceed shall be at the Bidder's risk.

Progress payments during the life of the contract will be permissible, with monthly invoices submitted in arrears for work performed from the first to the final day of the preceding month, with a 5% retainage being deducted. When the WORK under contract has been complete and its acceptance is recommended by the OWNER, the retainage shall be released and paid to the CONTRACTOR.

Please provide three (3) references for jobs of similar size and scope performed by your company in the past five (5) years:

References:

Reference Name: W.V. Cultural Center, Mark Lynch
Position: Maintenance Director
Address: 1900 Kanawha Blvd., Charleston, WV 25305
Telephone Number: 304-558-0220
Project Name: W.V. Cultural Center
Project Description: Renovations to Cultural Center First Floor & restroom

Reference Name: Anthony Thaxton
Position: Maintenance Director
Address: 1900 Kanawha Blvd., Charleston, WV 25305
Telephone Number: 304-558-4473
Project Name: Building 25 Restroom Renovations
Project Description: Restroom Renovations

Reference Name: Mike Maco
Position: Architect
Address: PO Box 59701, Charleston, WV 25309
Telephone Number: 304-746-5282
Project Name: USPS - Various Postal Projects
Project Description: Renovations

**Excerpt from 28 CFR Part 36:
ADA Standards for Accessible Design**

**Specifications Adopted by:
General Services Division Engineering Section**

4.2.4* Clear Floor or Ground Space for Wheelchairs.

4.2.4.1 Size and Approach. The minimum clear floor or ground space required to accommodate a single, stationary wheelchair and occupant is 30 in by 48 in (760 mm by 1220 mm) (see Fig. 4(a)). The minimum clear floor or ground space for wheelchairs may be positioned for forward or parallel approach to an object (see Fig. 4(b) and (c)). Clear floor or ground space for wheelchairs may be part of the knee space required under some objects.

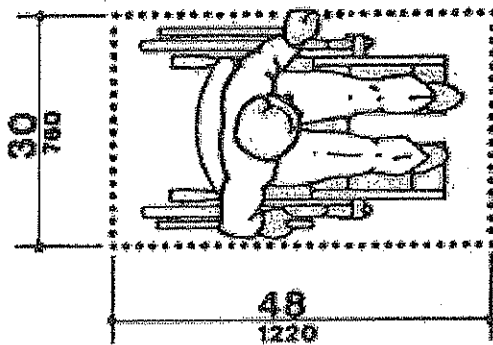

Figure 4a
Clear Floor Space

Clear floor space shown to be 30 by 48 inches minimum.

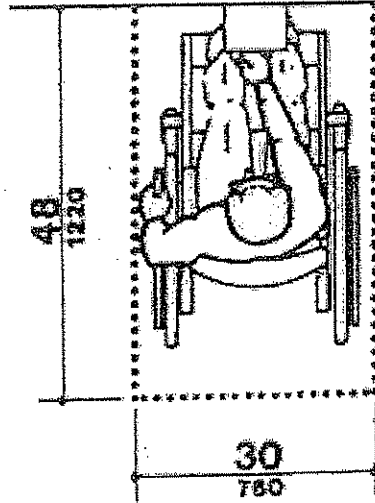

Figure 4b
Forward Approach

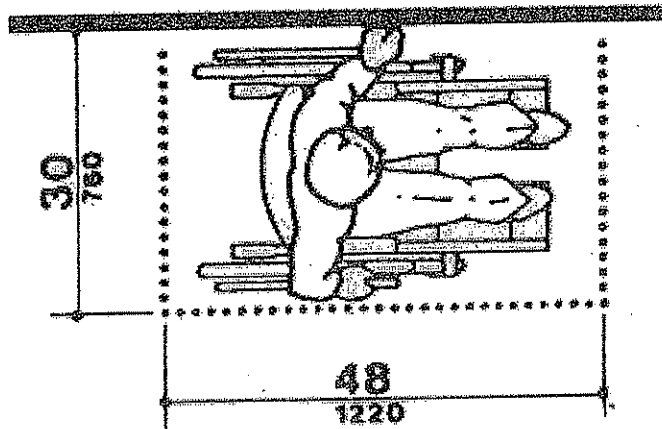

Figure 4c
Parallel Approach

4.2.4.2 Relationship of Maneuvering Clearance to Wheelchair Spaces. One full unobstructed side of the clear floor or ground space for a wheelchair shall adjoin or overlap an accessible route or adjoin another wheelchair clear floor space. If a clear floor space is located in an alcove or otherwise confined on all or part of three sides, additional maneuvering clearances shall be provided as shown in Fig. 4(d) and (e).

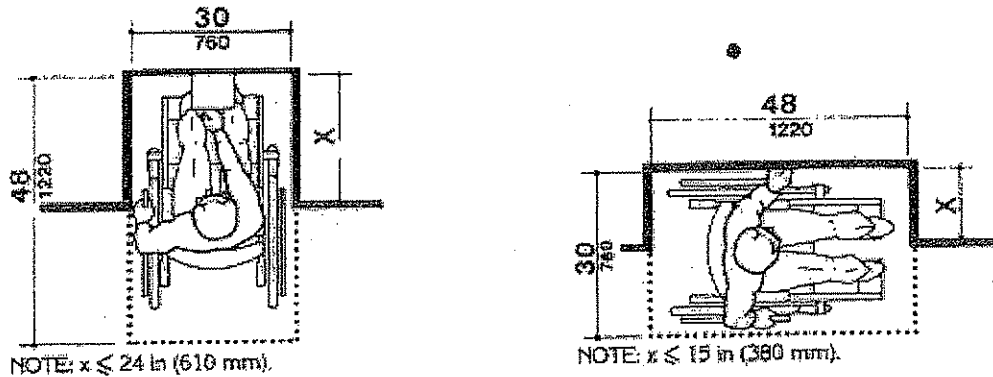

Figure 4d
Clear Floor Space in Alcoves

For a front approach, where the depth of the alcove is equal to or less than 24 inches (610 mm), the required clear floor space is 30 inches by 48 inches (760 mm by 1220 mm). For a side approach, where the depth of the alcove is equal to or less than 15 inches (380 mm), the required clear floor space is 30 inches by 48 inches (760 mm by 1220 mm).

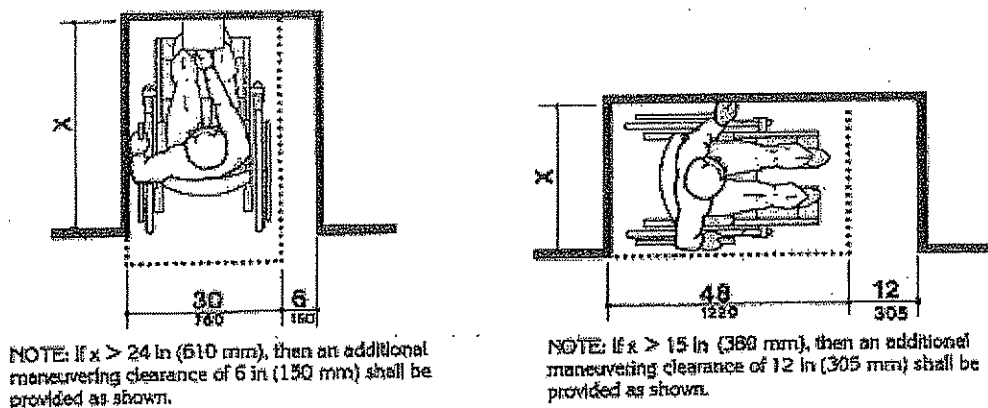

Figure 4e

Additional Maneuvering Clearance for Alcoves

For a front approach, if the depth of the alcove is greater than 24 inches (610 mm), then in addition to the 30 inch (760 mm) width, a maneuvering clearance of 6 inches (150 mm) in width is required. For a side approach, where the depth of the alcove is greater than 15 inches (380 mm), then in addition to the 48 inch (1220 mm) length, an additional maneuvering clearance of 12 inches in length (305 mm) is required.

4.16 Water Closets.

4.16.1 General. Accessible water closets shall comply with 4.16.2 through 4.16.6.

EXCEPTION: Water closets used primarily by children ages 12 and younger shall be permitted to comply with 4.16.7.

4.16.2 Clear Floor Space. Clear floor space for water closets not in stalls shall comply with Fig. 28. Clear floor space may be arranged to allow either a left-handed or right-handed approach.

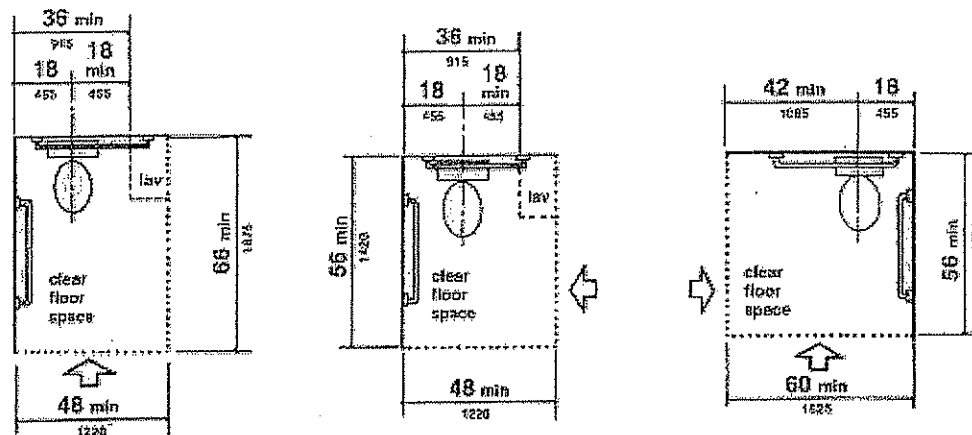

Figure 28
Clear Floor Space at Water Closets

4.16.3* Height. The height of water closets shall be 17 in to 19 in (430 mm to 485 mm), measured to the top of the toilet seat (see Fig. 29(b)). Seats shall not be sprung to return to a lifted position.

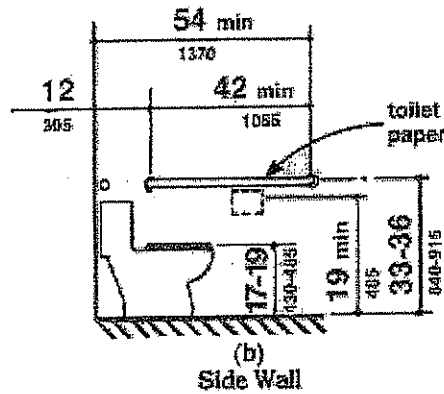

Figure 29b
Grab Bars at Water Closets
Side Wall

4.16.4* Grab Bars. Grab bars for water closets not located in stalls shall comply with 4.26 and Fig. 29. The grab bar behind the water closet shall be 36 in (915 mm) minimum.

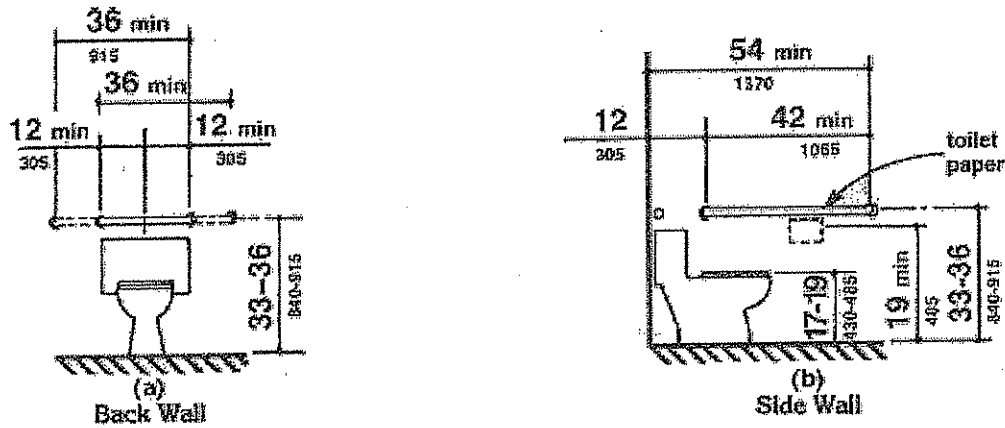

Figure 29
Grab Bars at Water Closets

4.16.5* Flush Controls. Flush controls shall be hand operated or automatic and shall comply with 4.27.4. Controls for flush valves shall be mounted on the wide side of toilet areas no more than 44 in (1120 mm) above the floor.

4.27.4 Operation. Controls and operating mechanisms shall be operable with one hand and shall not require tight grasping, pinching, or twisting of the wrist. The force required to activate controls shall be no greater than 5 lbf (22.2 N).

4.16.6 Dispensers. Toilet paper dispensers shall be installed within reach, as shown in Fig. 29(b). Dispensers that control delivery, or that do not permit continuous paper flow, shall not be used.

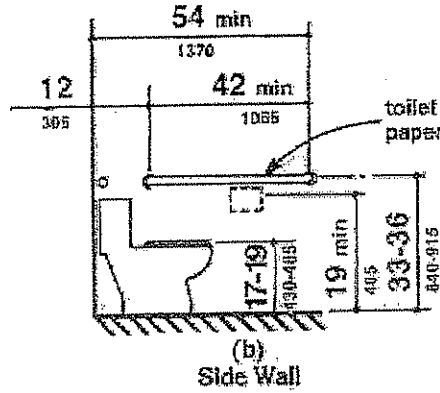

Figure 29b
Grab Bars at Water Closets
Side Wall

(1)

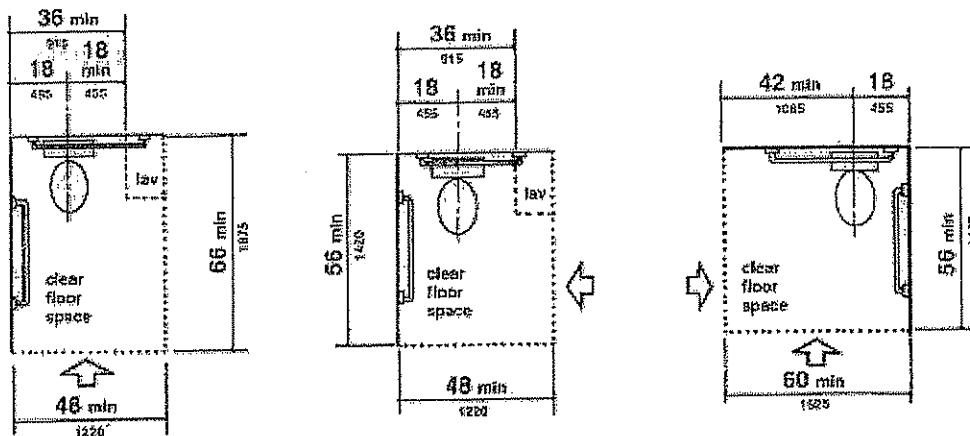

Figure 28
Clear Floor Space at Water Closets

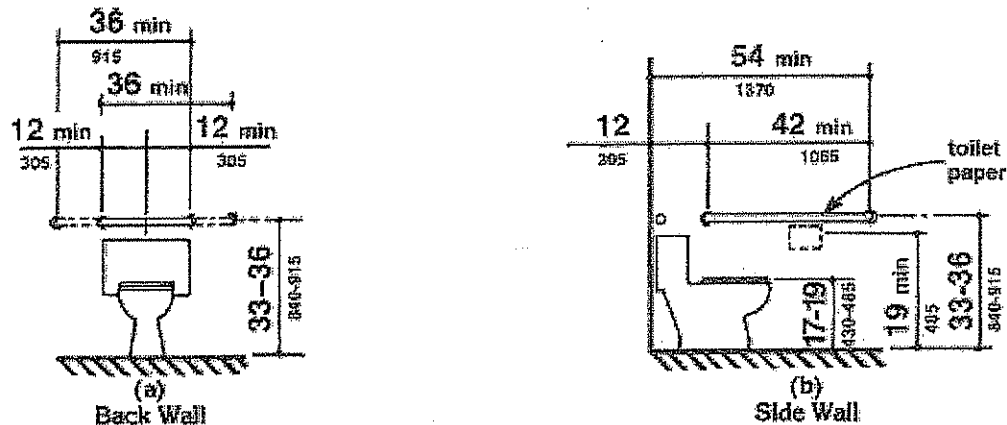

Figure 29
Grab Bars at Water Closets

EXCEPTION: If administrative authorities require flush controls for flush valves to be located in a position that conflicts with the location of the rear grab bar, then that grab bar may be split or, at water closets with a centerline placement below 15 in (380 mm), a rear grab bar 24 in (610 mm) minimum on the open side of the toilet area shall be permitted.

(4) Flush Controls. Flush controls shall be hand operated or automatic and shall comply with 4.27.4. Controls for flush valves shall be mounted on the wide side of the toilet area no more than 36 in (915 mm) above the floor.

(5) Dispensers. Toilet paper dispensers shall be installed 14 in minimum to 19 in maximum (355 mm to 485 mm) above the finish floor measured to the dispenser centerline. Dispensers that control delivery, or that do not permit continuous paper flow, shall not be used.

4.17 Toilet Stalls.

4.17.1 Location. Accessible toilet stalls shall be on an accessible route and shall meet the requirements of 4.17.2 through 4.17.6.

EXCEPTION: Toilet stalls used primarily by children ages 12 and younger shall be permitted to comply with 4.17.7.

4.17.2 Water Closets. Water closets in accessible stalls shall comply with 4.16.

4.17.3* Size and Arrangement. The size and arrangement of the standard toilet stall shall comply with Fig. 30(a), Standard Stall. Standard toilet stalls with a minimum depth of 56 in (1420 mm) (see Fig. 30(a)) shall have wall-mounted water closets. If the depth of a standard toilet stall is increased at least 3 in (75 mm), then a floor-mounted water closet may be used. Arrangements shown for standard toilet stalls may be reversed to allow either a left- or right-hand approach. Additional stalls shall be provided in conformance with 4.22.4.

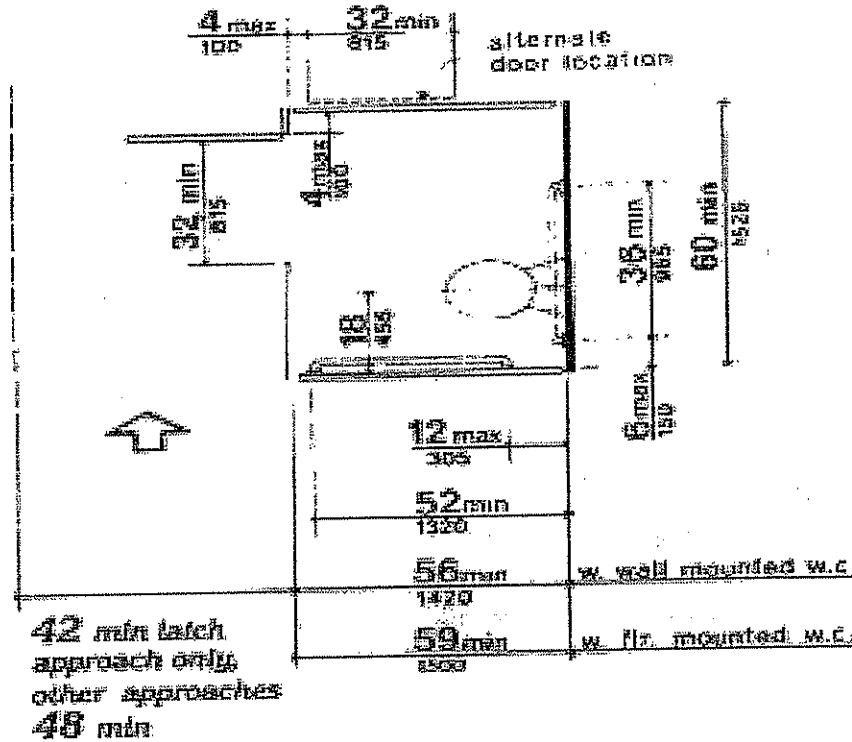

Figure 30a
Toilet Stalls
Standard Stall

EXCEPTION: In instances of alteration work where provision of a standard stall (Fig. 30(a)) is technically infeasible or where plumbing code requirements prevent combining existing stalls to provide space, either alternate stall (Fig. 30(b)) may be provided in lieu of the standard stall.

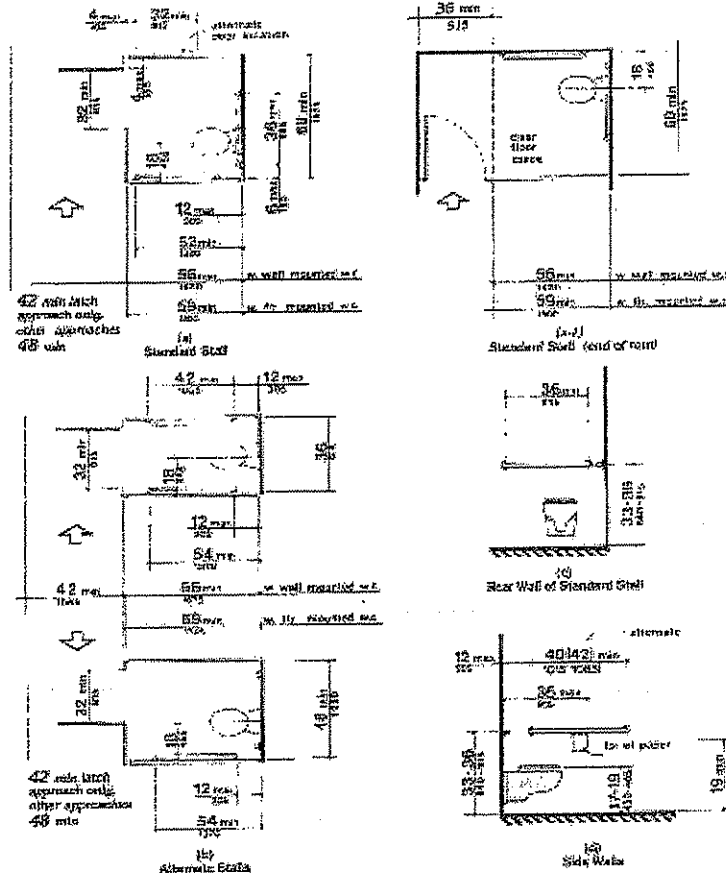

Figure 30
Toilet Stalls

4.17.6 Grab Bars. Grab bars complying with the length and positioning shown in Fig. 30(a), (b), (c), and (d) shall be provided. Grab bars may be mounted with any desired method as long as they have a gripping surface at the locations shown and do not obstruct the required clear floor area. Grab bars shall comply with 4.26.

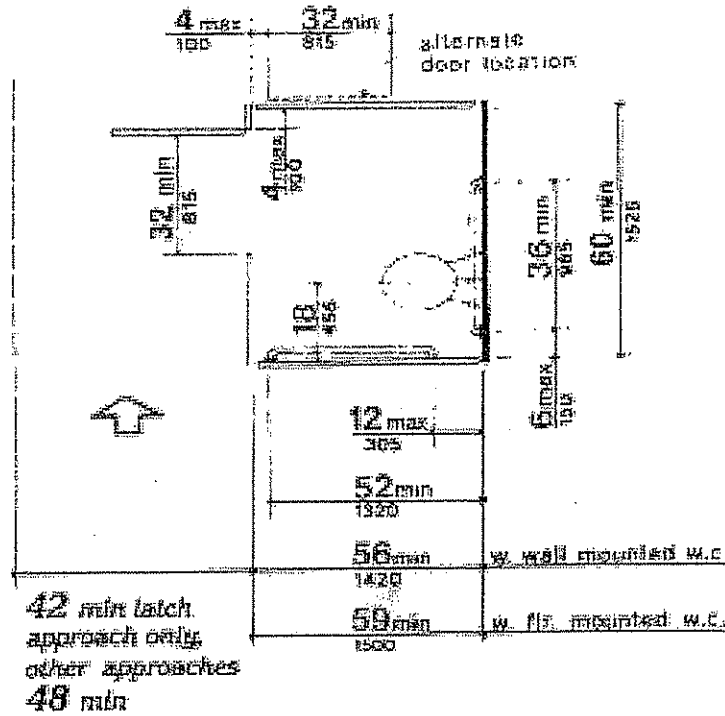

Figure 30a
Toilet Stalls
Standard Stall

The location of the door is illustrated to be in front of the clear space (next to the water closet), with a maximum stile width of 4 inches (100 mm). An alternate door location is illustrated to be on the side of the toilet stall with a maximum stile width of 4 inches (100 mm). The minimum width of the standard stall shall be 60 inches (1525 mm). The centerline of the water closet shall be 18 inches (455 mm) from the side wall.

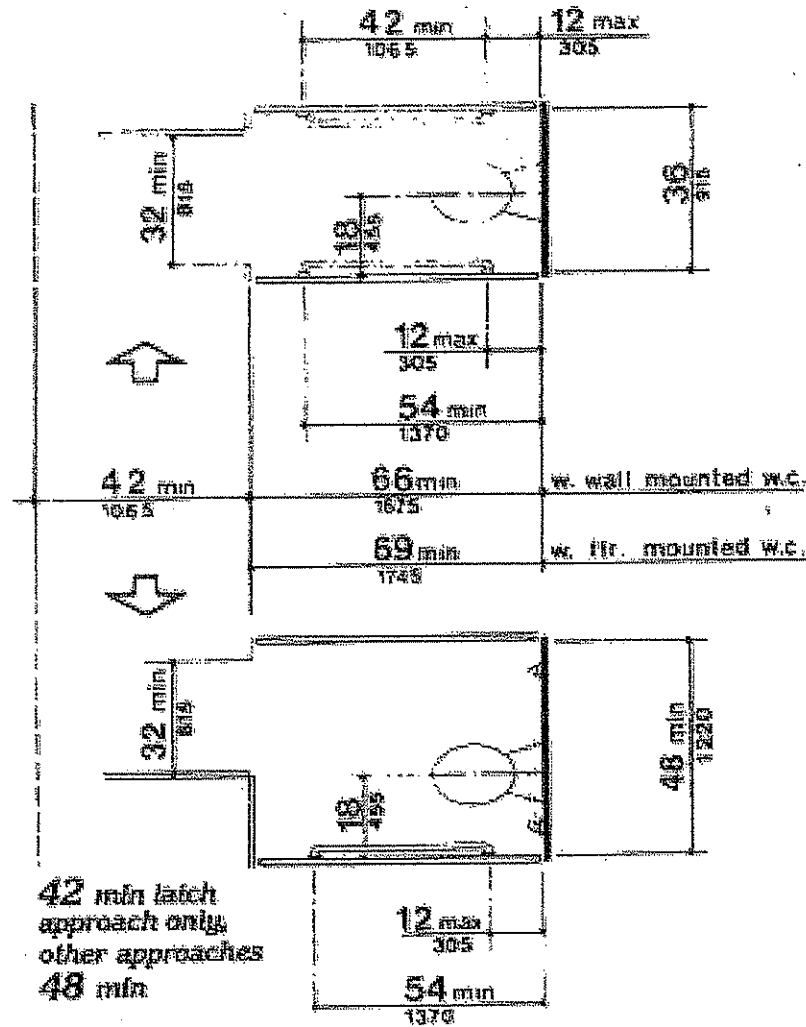

Figure 30b
Toilet Stalls
Alternate Stalls

Two alternate stalls are illustrated; one alternate stall is required to be 36 inches (915 mm) in width. The other alternate stall is required to be a minimum of 48 inches (1220 mm) in width. If a wall mounted water closet is used, the depth of the stall is required to be a minimum of 66 inches (1675 mm). If a floor mounted water closet is used, the depth of the stall is required to be a minimum of 69 inches (1745 mm). The 36 inch wide stall shall have parallel grab bars on the side walls. The 48 inch minimum stall shall have a grab bar behind the water closet and one on the side wall next to the water closet. In each alternate, the centerline of the water closet is 18 inches (455 mm) from a side wall.

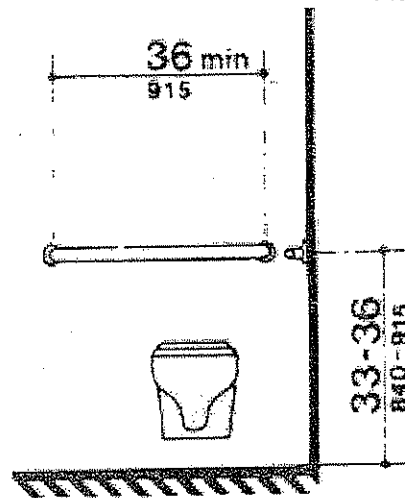

Figure 30c
Toilet Stalls
Rear Wall of Standard Stall

The grab bar on the back wall shall be 36 inches minimum in length, extending from the wall toward the open side of the water closet, 33-36 inches above the finish floor.

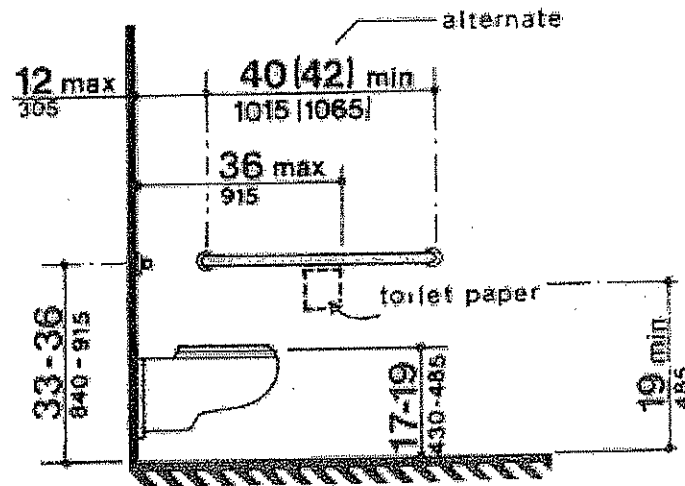

Figure 30d
Toilet Stalls

The side grab bar shall be 40-42 inches in length, beginning 12 inches maximum from the rear wall, 33-36 inches above the finish floor.

4.18 Urinals.

4.18.1 General. Accessible urinals shall comply with 4.18.

4.18.2 Height. Urinals shall be stall-type or wall-hung with an elongated rim at a maximum of 17 in (430 mm) above the finish floor.

4.18.3 Clear Floor Space. A clear floor space 30 in by 48 in (760 mm by 1220 mm) shall be provided in front of urinals to allow forward approach. This clear space shall adjoin or overlap an accessible route and shall comply with 4.2.4. Urinal shields that do not extend beyond the front edge of the urinal rim may be provided with 29 in (735 mm) clearance between them.

4.18.4 Flush Controls. Flush controls shall be hand operated or automatic, and shall comply with 4.27.4, and shall be mounted no more than 44 in (1120 mm) above the finish floor.

4.19 Lavatories and Mirrors.

4.19.1 General. The requirements of 4.19 shall apply to lavatory fixtures, vanities, and built-in lavatories.

4.19.2 Height and Clearances. Lavatories shall be mounted with the rim or counter surface no higher than 34 in (865 mm) above the finish floor. Provide a clearance of at least 29 in (735 mm) above the finish floor to the bottom of the apron. Knee and toe clearance shall comply with Fig. 31.

EXCEPTION 1: Lavatories used primarily by children ages 6 through 12 shall be permitted to have an apron clearance and a knee clearance 24 in (610 mm) high minimum provided that the rim or counter surface is no higher than 31 in (760 mm).

EXCEPTION 2: Lavatories used primarily by children ages 5 and younger shall not be required to meet these clearances if clear floor space for a parallel approach complying with 4.2.4 is provided.

4.19.3 Clear Floor Space. A clear floor space 30 in by 48 in (760 mm by 1220 mm) complying with 4.2.4 shall be provided in front of a lavatory to allow forward approach. Such clear floor space shall adjoin or overlap an accessible route and shall extend a maximum of 19 in (485 mm) underneath the lavatory (see Fig. 32).

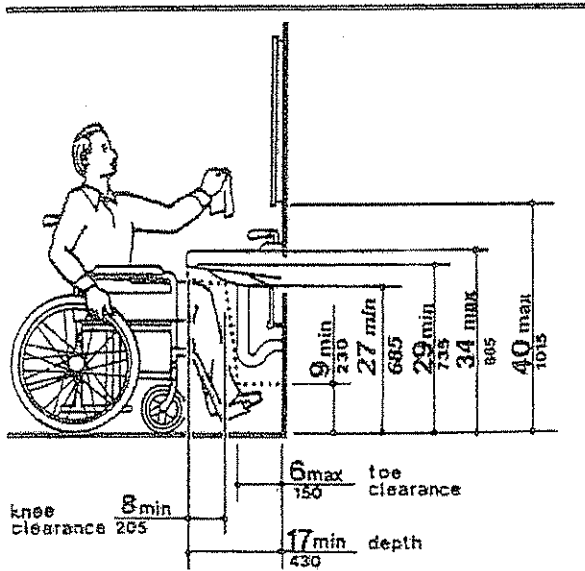

Fig. 31
Lavatory Clearances

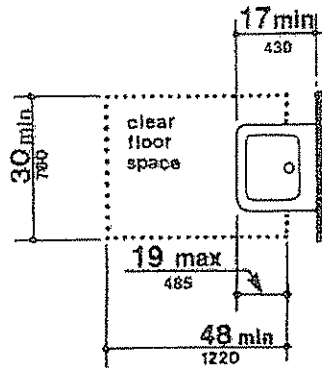

Fig. 32
Clear Floor Space at Lavatories

4.19.4 Exposed Pipes and Surfaces. Hot water and drain pipes under lavatories shall be insulated or otherwise configured to protect against contact. There shall be no sharp or abrasive surfaces under lavatories.

4.19.5 Faucets. Faucets shall comply with 4.27.4. Lever-operated, push-type, and electronically controlled mechanisms are examples of acceptable designs. If self-closing valves are used the faucet shall remain open for at least 10 seconds.

4.19.6* Mirrors. Mirrors shall be mounted with the bottom edge of the reflecting surface no higher than 40 in (1015 mm) above the finish floor (see Fig. 31).

4.20.4 Grab Bars. Grab bars complying with 4.26 shall be provided as shown in Fig. 33 and 34.

4.20.5 Controls. Faucets and other controls complying with 4.27.4 shall be located as shown in Fig. 34.

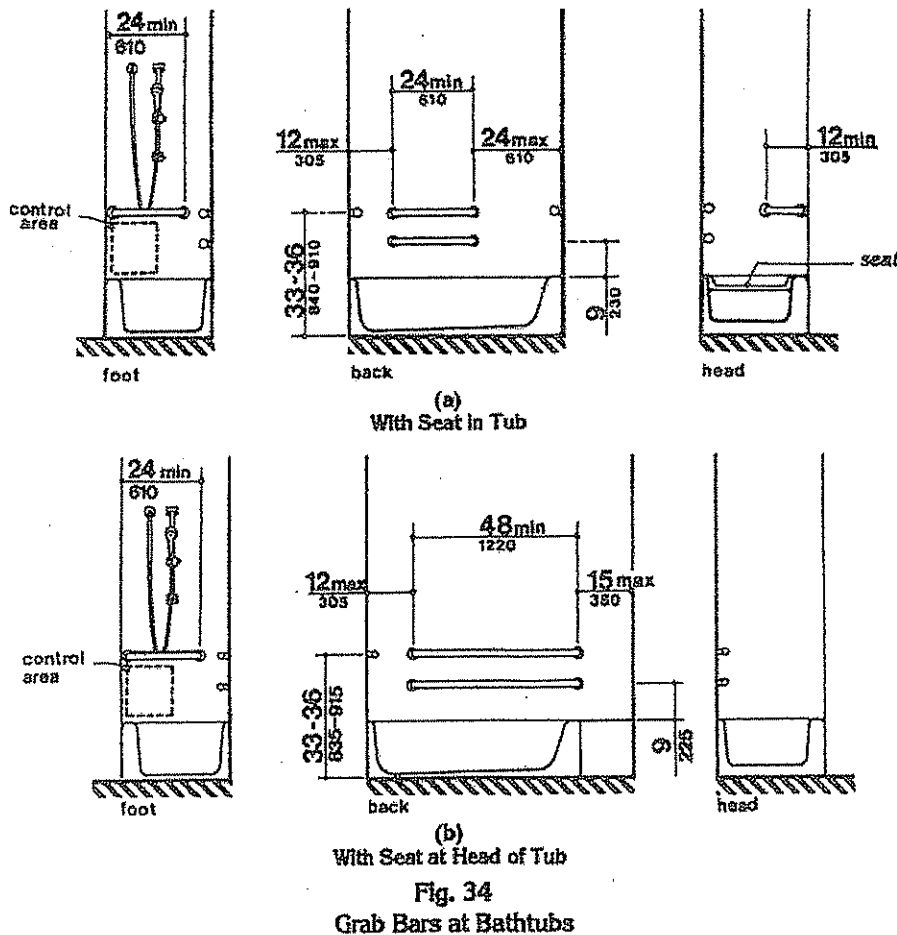

4.20.6 Shower Unit. A shower spray unit with a hose at least 60 in (1525 mm) long that can be used both as a fixed shower head and as a hand-held shower shall be provided.

4.21 Shower Stalls.

4.21.1* **General.** Accessible shower stalls shall comply with 4.21.

4.21.2 **Size and Clearances.** Except as specified in 9.1.2, shower stall size and clear floor space shall comply with Fig. 35(a) or (b). The shower stall in Fig. 35(a) shall be 36 in by 36 in (915 mm by 915 mm). Shower stalls required by 9.1.2 shall comply with Fig. 57(a) or (b). The shower stall in Fig. 35(b) will fit into the space required for a bathtub.

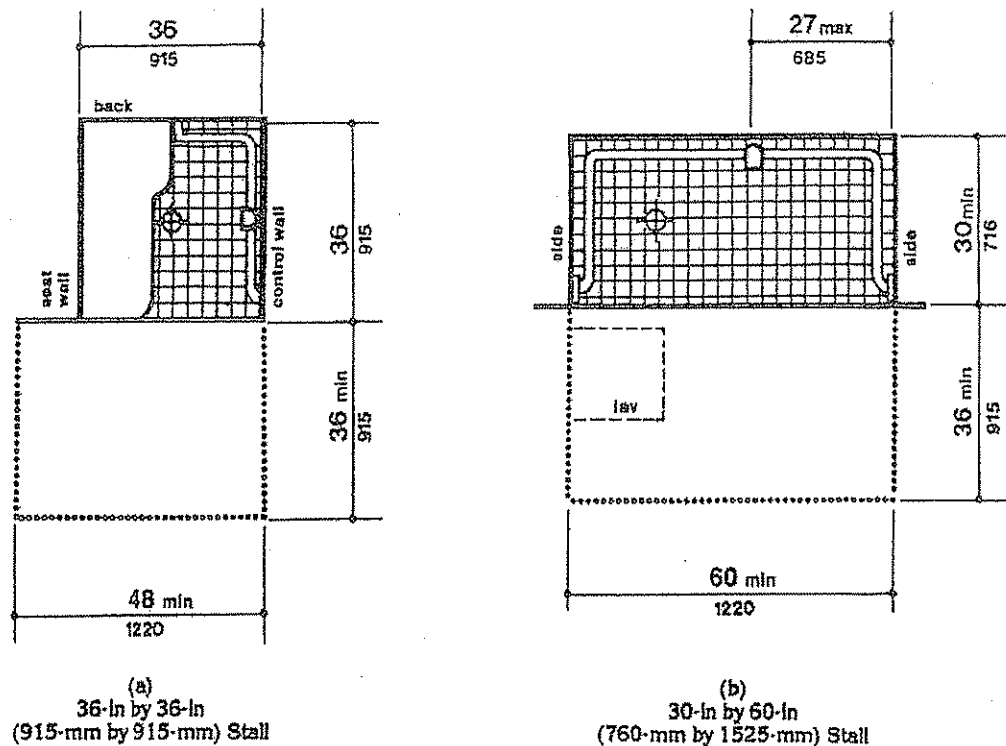

Fig. 35
Shower Size and Clearances

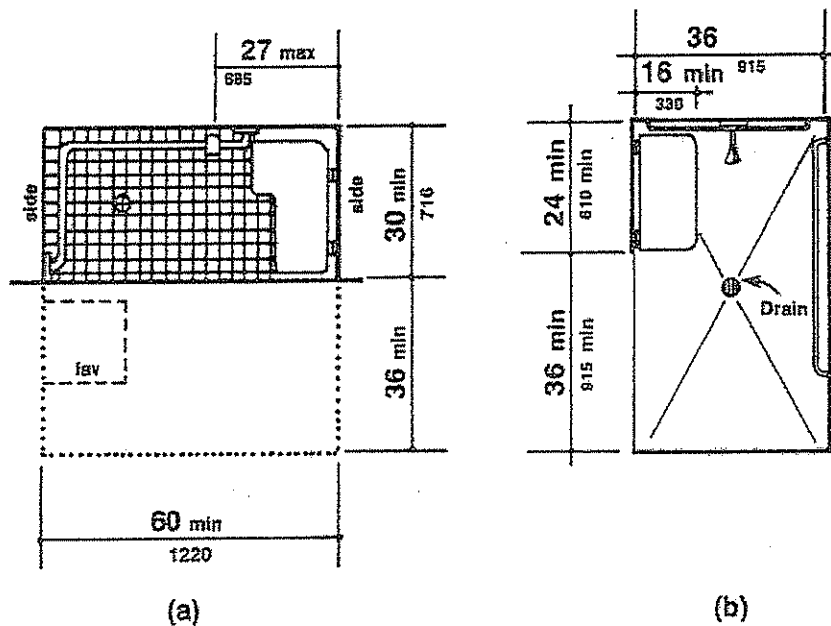

Fig. 57
Roll-in Shower with Folding Seat

4.21.3 Seat. A seat shall be provided in shower stalls 36 in by 36 in (915 mm by 915 mm) and shall be as shown in Fig. 36. The seat shall be mounted 17 in to 19 in (430 mm to 485 mm) from the bathroom floor and shall extend the full depth of the stall. In a 36 in by 36 in (915 mm by 915 mm) shower stall, the seat shall be on the wall opposite the controls. *Where a fixed seat is provided in a 30 in by 60 in minimum (760 mm by 1525 mm) shower stall, it shall be a folding type and shall be mounted on the wall adjacent to the controls as shown in Fig. 57.* The structural strength of seats and their attachments shall comply with 4.26.3.

4.21.4 Grab Bars. Grab bars complying with 4.26 shall be provided as shown in Fig. 37.

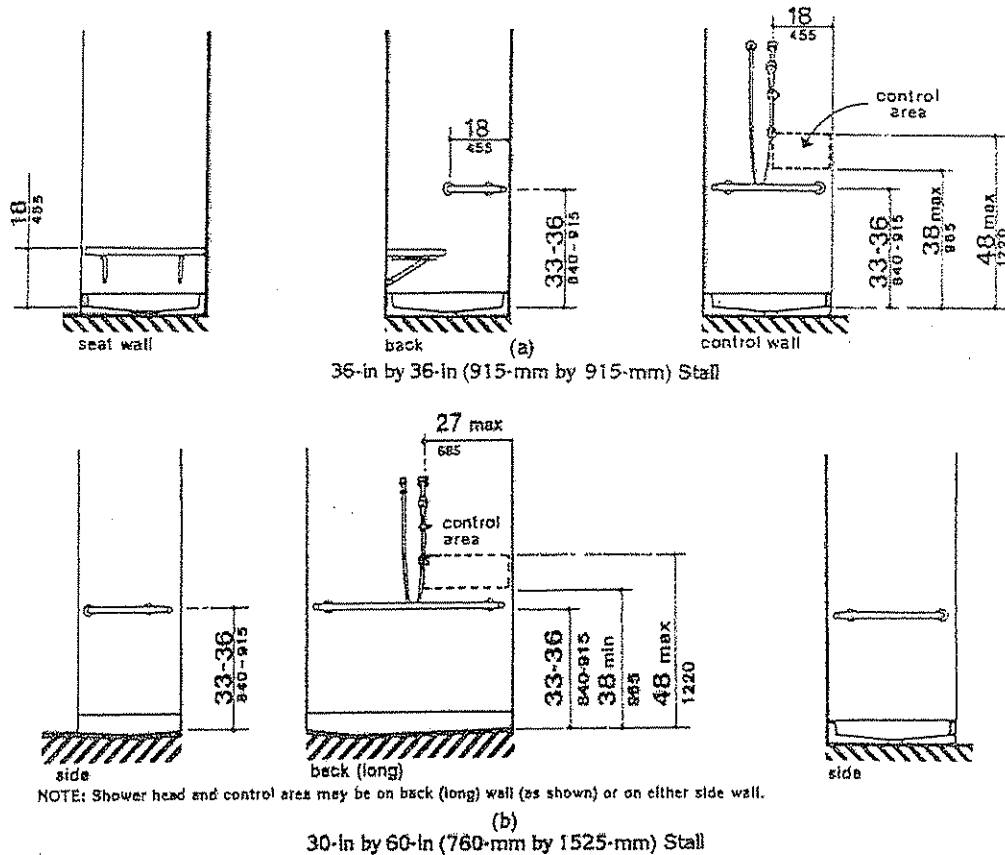

Fig. 37

Grab Bars at Shower Stalls

4.21.5 Controls. Faucets and other controls complying with 4.27.4 shall be located as shown in Fig. 37. In shower stalls 36 in by 36 in (915 mm by 915 mm), all controls, faucets, and the shower unit shall be mounted on the side wall opposite the seat.

4.21.6 Shower Unit. A shower spray unit with a hose at least 60 in (1525 mm) long that can be used both as a fixed shower head and as a hand-held shower shall be provided. *EXCEPTION: In unmonitored facilities where vandalism is a consideration, a fixed shower head mounted at 48 in (1220 mm) above the shower floor may be used in lieu of a hand-held shower head.*

4.21.7 Curbs. If provided, curbs in shower stalls 36 in by 36 in (915 mm by 915 mm) shall be no higher than 1/2 in (13 mm). Shower stalls that are 30 in by 60 in (760 mm by 1525 mm) minimum shall not have curbs.

4.21.8 Shower Enclosures. If provided, enclosures for shower stalls shall not obstruct controls or obstruct transfer from wheelchairs onto shower seats.

4.22 Toilet Rooms.

4.22.1 Minimum Number. *Toilet facilities required to be accessible by 4.1 shall comply*

4.22.2 Doors. All doors to accessible toilet rooms shall comply with 4.13. Doors shall not swing into the clear floor space required for any fixture.

4.22.3* Clear Floor Space. The accessible fixtures and controls required in 4.22.4, 4.22.5, 4.22.6, and 4.22.7 shall be on an accessible route. An unobstructed turning space complying with 4.2.3 shall be provided within an accessible toilet room. The clear floor space at fixtures and controls, the accessible route, and the turning space may overlap.

4.22.4 Water Closets. If toilet stalls are provided, then at least one shall be a standard toilet stall complying with 4.17; *where 6 or more stalls are provided, in addition to the stall complying with 4.17.3, at least one stall 36 in (915 mm) wide with an outward swinging, self-closing door and parallel grab bars complying with Fig. 30(d) and 4.26 shall be provided. Water closets in such stalls shall comply with 4.16.* If water closets are not in stalls, then at least one shall comply with 4.16.

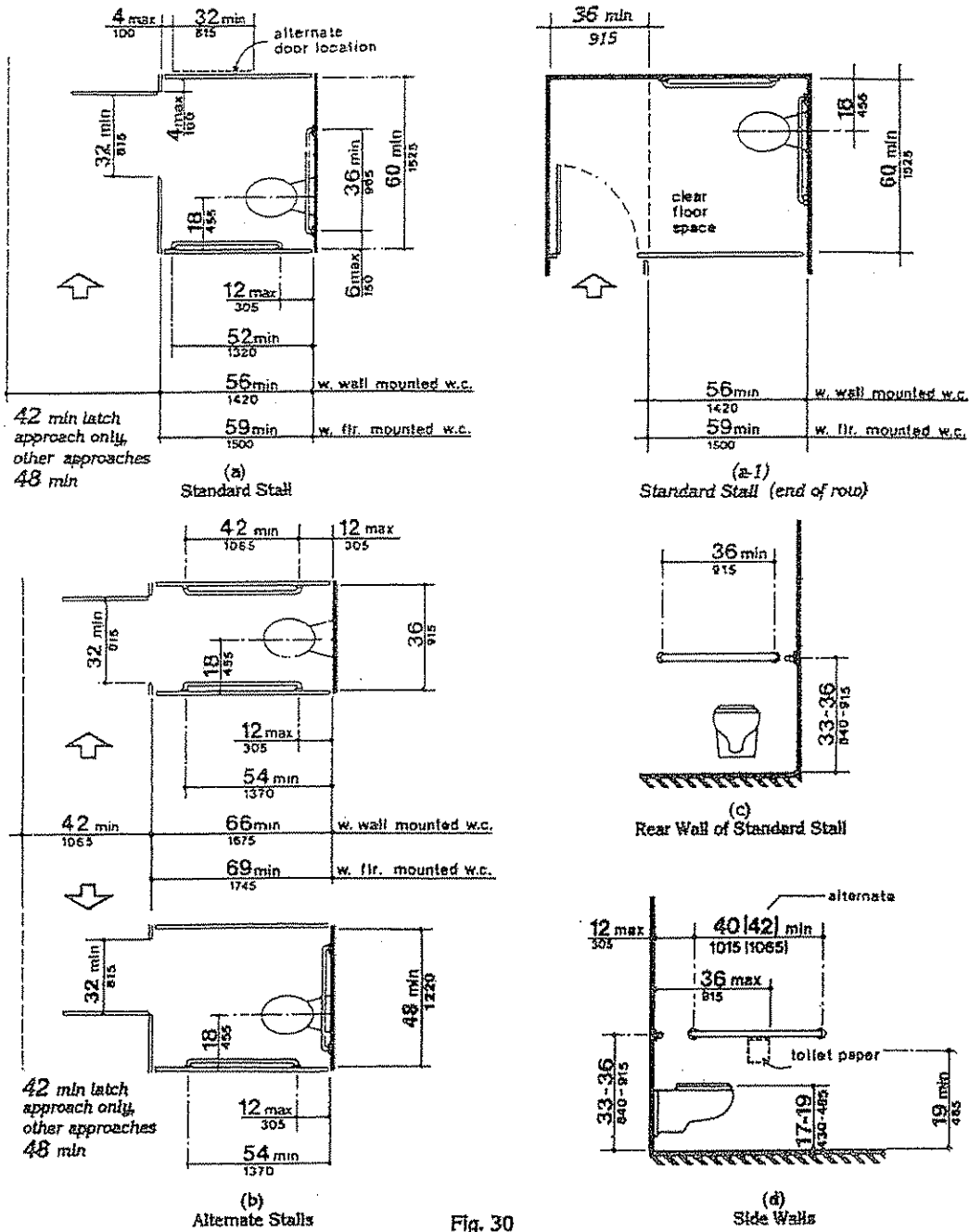

Fig. 30
Toilet Stalls

4.22.5 Urinals. If urinals are provided, *then* at least one shall comply with 4.18.

4.22.6 Lavatories and Mirrors. If lavatories and mirrors are provided, *then* at least one of each shall comply with 4.19.

4.22.7 Controls and Dispensers.

If controls, dispensers, receptacles, or other equipment are provided, *then* at least one of each shall be on an accessible route and shall comply with 4.27.

4.23 Bathrooms, Bathing Facilities, and Shower Rooms.

4.23.1 Minimum Number. Bathrooms, bathing facilities, or shower rooms *required to be accessible by 4.1* shall comply with 4.23 and shall be on an accessible route.

4.23.2 Doors. Doors to accessible bathrooms shall comply with 4.13. Doors shall not swing into the floor space required for any fixture.

4.23.3* Clear Floor Space. The accessible fixtures and controls required in 4.23.4, 4.23.5, 4.23.6, 4.23.7, 4.23.8, and 4.23.9 shall be on an accessible route. An unobstructed turning space complying with 4.2.3 shall be provided within an accessible bathroom. The clear floor spaces at fixtures and controls, the accessible route, and the turning space may overlap.

4.23.4 Water Closets. If toilet stalls are provided, then at least one shall be a standard toilet stall complying with 4.17; *where 6 or more stalls are provided, in addition to the stall complying with 4.17.3, at least one stall 36 in (915 mm) wide with an outward swinging, self-closing door and parallel grab bars complying with Fig. 30(d) and 4.26 shall be provided.* Water closets in such stalls shall comply with 4.16. If water closets are not in stalls, then at least one shall comply with 4.16.

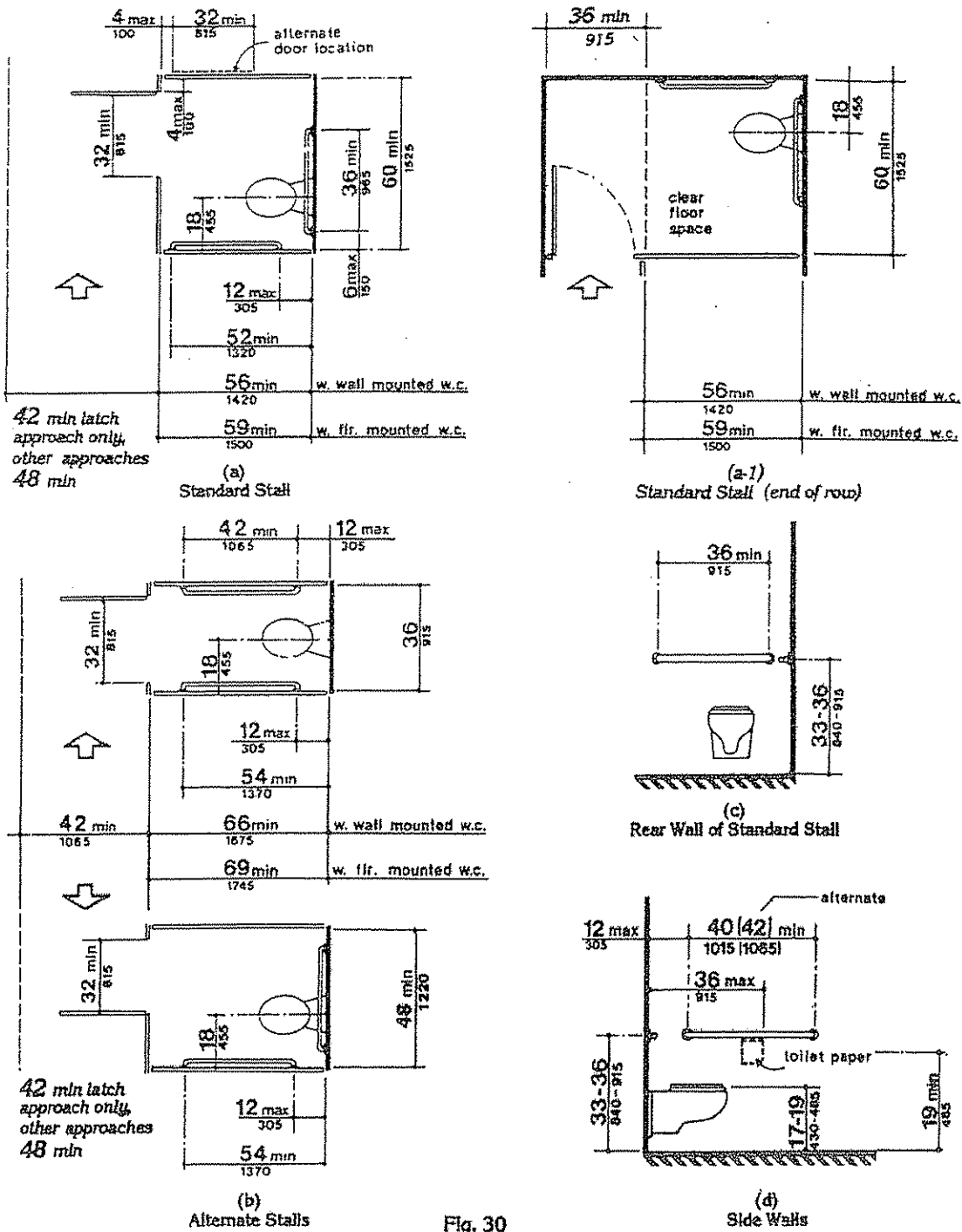

Fig. 30
Toilet Stalls

4.23.5 Urinals. If urinals are provided, then at least one shall comply with 4.18.

4.23.6 Lavatories and Mirrors. If lavatories and mirrors are provided, then at least one of each shall comply with 4.19.

4.23.7 Controls and Dispensers. If controls, dispensers, receptacles, or other equipment are provided, then at least one of each shall be on an accessible route and shall comply with 4.27.

4.23.8 Bathing and Shower Facilities. If tubs or showers are provided, then at least one accessible tub that complies with 4.20 or at least one accessible shower that complies with 4.21 shall be provided.

4.24 Sinks.

4.24.1 General. Sinks *required to be accessible by 4.1* shall comply with 4.24.

4.24.2 Height. Sinks shall be mounted with the counter or rim no higher than 34 in (865 mm) *above the finish floor.*

4.24.3 Knee Clearance. Knee clearance that is at least 27 in (685 mm) high, 30 in (760 mm) wide, and 19 in (485 mm) deep shall be provided underneath sinks.

4.24.4 Depth. Each sink shall be a maximum of 6-1/2 in (165 mm) deep.

4.24.5 Clear Floor Space. A clear floor space at least 30 in by 48 in (760 mm by 1220 mm) complying with 4.2.4 shall be provided in front of a sink to allow forward approach. The clear floor space shall be on an accessible route and shall extend a maximum of 19 in (485 mm) underneath the sink (see Fig. 32).

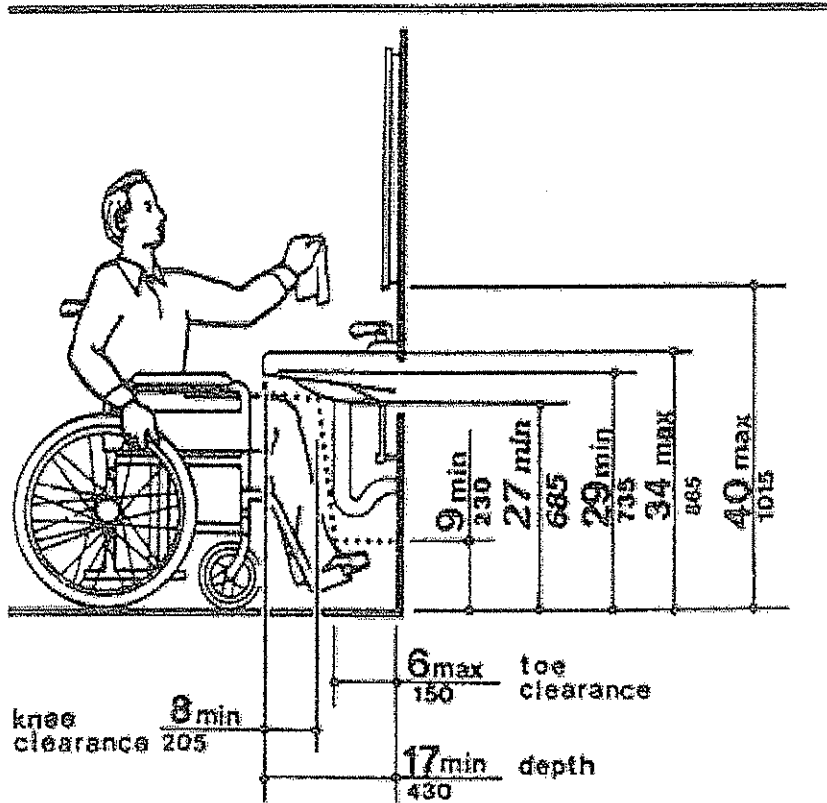

Fig. 31
Lavatory Clearances

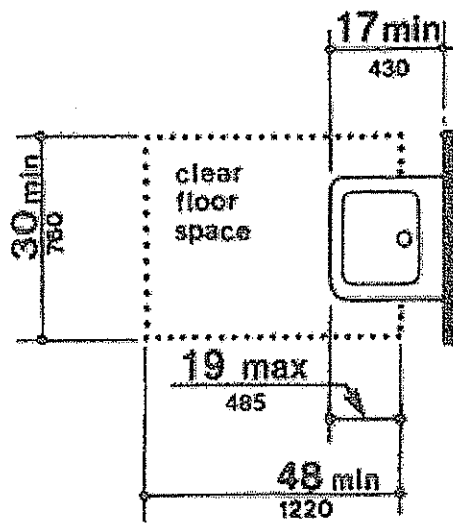

Fig. 32
Clear Floor Space at Lavatories

4.24.6 Exposed Pipes and Surfaces. Hot water and drain pipes exposed under sinks shall be insulated or otherwise *configured so as to protect against contact*. There shall be no sharp or abrasive surfaces under sinks.

4.24.7 Faucets. Faucets shall comply with 4.27.4. Lever-operated, push-type, touch-type, or electronically controlled mechanisms are acceptable designs.

4.26.1* General. All handrails, grab bars, and tub and shower seats *required to be accessible by 4.1, 4.8, 4.9, 4.16, 4.17, 4.20 or 4.21* shall comply with 4.26.

4.26.2* Size and Spacing of Grab Bars and Handrails. The diameter or width of the gripping surfaces of a handrail or grab bar shall be 1-1/4 in to 1-1/2 in (32 mm to 38 mm), or the shape shall provide an equivalent gripping surface. If handrails or grab bars are mounted adjacent to a wall, the space between the wall and the grab bar shall be 1-1/2 in (38 mm) (see Fig. 39(a), (b), (c), and (e)). Handrails may be located in a recess if the recess is a maximum of 3 in (75 mm) deep and extends at least 18 in (455 mm) above the top of the rail (see Fig. 39(d)).

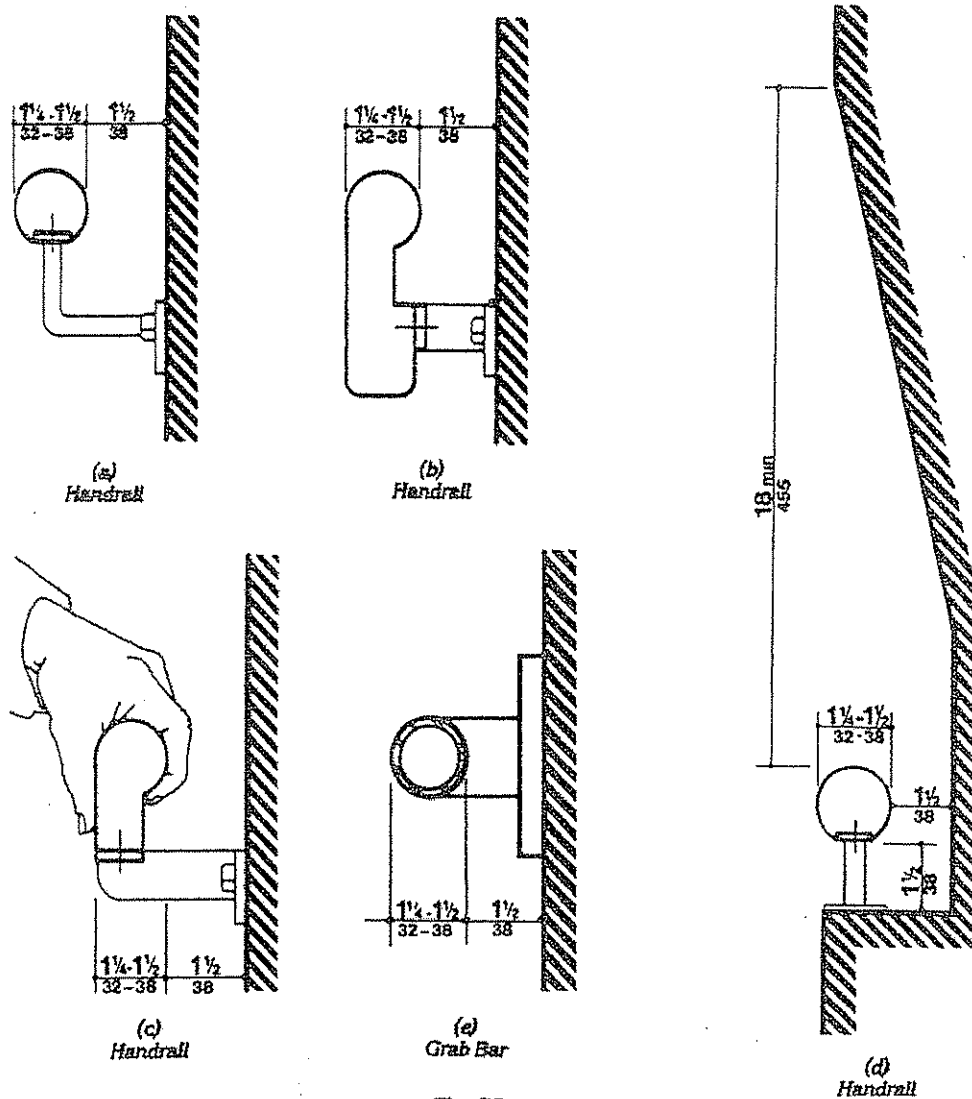

Fig. 39
Size and Spacing of Handrails and Grab Bars

4.26.3 Structural Strength. The structural strength of grab bars, tub and shower seats, fasteners, and mounting devices shall meet the following specification:

- (1) Bending stress in a grab bar or seat induced by the maximum bending moment from the application of 250 lbf (1112N) shall be less than the allowable stress for the material of the grab bar or seat.
- (2) Shear stress induced in a grab bar or seat by the application of 250 lbf (1112N) shall be less than the allowable shear stress for the material of the grab bar or seat. If the connection between the grab bar or seat and its mounting bracket or other support is considered to be fully restrained, then direct and

torsional shear stresses shall be totaled for the combined shear stress, which shall not exceed the allowable shear stress.

(3) Shear force induced in a fastener or mounting device from the application of 250 lbf (1112N) shall be less than the allowable lateral load of either the fastener or mounting device or the supporting structure, whichever is the smaller allowable load.

(4) Tensile force induced in a fastener by a direct tension force of 250 lbf (1112N) plus the maximum moment from the application of 250 lbf (1112N) shall be less than the allowable withdrawal load between the fastener and the supporting structure.

(5) Grab bars shall not rotate within their fittings.

4.26 Handrails, Grab Bars, and Tub and Shower Seats

4.26.4 Eliminating Hazards. A handrail or grab bar and any wall or other surface adjacent to it shall be free of any sharp or abrasive elements. Edges shall have a minimum radius of 1/8 in (3.2 mm).

4.27 Controls and Operating Mechanisms.4.27.1 General. Controls and operating mechanisms required to be accessible by 4.1 shall comply with 4.27.

4.27.2 Clear Floor Space. Clear floor space complying with 4.2.4 that allows a forward or a parallel approach by a person using a wheelchair shall be provided at controls, dispensers, receptacles, and other operable equipment.

4.27.3* Height. The highest operable part of controls, dispensers, receptacles, and other operable equipment shall be placed within at least one of the reach ranges specified in 4.2.5 and 4.2.6. Electrical and communications system receptacles on walls shall be mounted no less than 15 in (380 mm) above the floor. *EXCEPTION: These requirements do not apply where the use of special equipment dictates otherwise or where electrical and communications systems receptacles are not normally intended for use by building occupants.*

4.27.4 Operation. Controls and operating mechanisms shall be operable with one hand and shall not require tight grasping, pinching, or twisting of the wrist. The force required to activate controls shall be no greater than 5 lbf (22.2 N).



State of West Virginia
DRUG FREE WORKPLACE CONFORMANCE AFFIDAVIT
West Virginia Code §21-1D-5

STATE OF West Virginia
COUNTY OF Fayette, TO-WIT:

I, Robert D Hill, after being first duly sworn, depose and state as follows:

- 1. I am an employee of Danhill Construction Company; and,
(Company Name)
- 2. I do hereby attest that Danhill Construction Company
(Company Name)

maintains a valid written drug free workplace policy and that such policy is in compliance with **West Virginia Code** §21-1D-5.

The above statements are sworn to under the penalty of perjury.

Danhill Construction Company
(Company Name)

By: Robert D. Hill

Title: Pres.

Date: 5-19-09

Taken, subscribed and sworn to before me this 19 day of May, 2009.

By Commission expires 3/28/2015

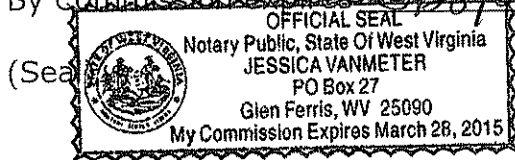

Jessica VanMeter
(Notary Public)

THIS AFFIDAVIT MUST BE SUBMITTED WITH THE BID IN ORDER TO COMPLY WITH WV CODE PROVISIONS. FAILURE TO INCLUDE THE AFFIDAVIT WITH THE BID SHALL RESULT IN DISQUALIFICATION OF THE BID.

1952 JACOB
STANLEY A. JACOB
15 N. B. ST.
WASH. D. C. 20540
U.S. AIR FORCE

STATE OF WEST VIRGINIA
Purchasing Division

PURCHASING AFFIDAVIT

VENDOR OWING A DEBT TO THE STATE:

West Virginia Code §5A-3-10a provides that: No contract or renewal of any contract may be awarded by the state or any of its political subdivisions to any vendor or prospective vendor when the vendor or prospective vendor or a related party to the vendor or prospective vendor is a debtor and the debt owed is an amount greater than one thousand dollars in the aggregate.

PUBLIC IMPROVEMENT CONTRACTS & DRUG-FREE WORKPLACE ACT:

If this is a solicitation for a public improvement construction contract, the vendor, by its signature below, affirms that it has a written plan for a drug-free workplace policy in compliance with Article 1D, Chapter 21 of the *West Virginia Code*. The vendor **must** make said affirmation with its bid submission. Further, public improvement construction contract may not be awarded to a vendor who does not have a written plan for a drug-free workplace policy in compliance with Article 1D, Chapter 21 of the *West Virginia Code* and who has not submitted that plan to the appropriate contracting authority in timely fashion. For a vendor who is a subcontractor, compliance with Section 5, Article 1D, Chapter 21 of the *West Virginia Code* may take place before their work on the public improvement is begun.

ANTITRUST:

In submitting a bid to any agency for the state of West Virginia, the bidder offers and agrees that if the bid is accepted the bidder will convey, sell, assign or transfer to the state of West Virginia all rights, title and interest in and to all causes of action it may now or hereafter acquire under the antitrust laws of the United States and the state of West Virginia for price fixing and/or unreasonable restraints of trade relating to the particular commodities or services purchased or acquired by the state of West Virginia. Such assignment shall be made and become effective at the time the purchasing agency tenders the initial payment to the bidder.

I certify that this bid is made without prior understanding, agreement, or connection with any corporation, firm, limited liability company, partnership or person or entity submitting a bid for the same materials, supplies, equipment or services and is in all respects fair and without collusion or fraud. I further certify that I am authorized to sign the certification on behalf of the bidder or this bid.

LICENSING:

Vendors must be licensed and in good standing in accordance with any and all state and local laws and requirements by any state or local agency of West Virginia, including, but not limited to, the West Virginia Secretary of State's Office, the West Virginia Tax Department, West Virginia Insurance Commission, or any other state agencies or political subdivision. Furthermore, the vendor must provide all necessary releases to obtain information to enable the Director or spending unit to verify that the vendor is licensed and in good standing with the above entities.

CONFIDENTIALITY:

The vendor agrees that he or she will not disclose to anyone, directly or indirectly, any such personally identifiable information or other confidential information gained from the agency, unless the individual who is the subject of the information consents to the disclosure in writing or the disclosure is made pursuant to the agency's policies, procedures and rules. Vendor further agrees to comply with the Confidentiality Policies and Information Security Accountability Requirements, set forth in <http://www.state.wv.us/admin/purchase/privacy/noticeConfidentiality.pdf>.

Under penalty of law for false swearing (*West Virginia Code* §61-5-3), it is hereby certified that the vendor affirms and acknowledges the information in this affidavit and is in compliance with the requirements as stated.

Vendor's Name: Dankill Construction Company
Authorized Signature: Robert D. Hill Date: 5-19-09





State of West Virginia
 Department of Administration
 Purchasing Division
 2019 Washington Street East
 Post Office Box 50130
 Charleston, WV 25305-0130

Request for Quotation

RFQ NUMBER
 GSD096451

PAGE
 1

ADDRESS CORRESPONDENCE TO ATTENTION OF
 KRISTA FERRELL
 304-558-2596

VENDOR

*709053330 304-632-1558
 DANHILL CONSTRUCTION COMPANY
 PO BOX 685
 GAULEY BRIDGE WV 25085

SHIP TO

DEPARTMENT OF ADMINISTRATION
 GENERAL SERVICES DIVISION
 BUILDING 84 CORNERSTONE
 1409 GREENBRIER ST
 CHARLESTON WV
 25311 304-558-2317

DATE PRINTED	TERMS OF SALE	SHIP VIA	F.O.B.	FREIGHT TERMS
05/08/2009				

BID OPENING DATE: 05/19/2009 BID OPENING TIME 01:30PM

LINE	QUANTITY	UOP	CAT. NO.	ITEM NUMBER	UNIT PRICE	AMOUNT
				ADDENDUM NO. 1		
				THIS ADDENDUM IS TO:		
				1.) ANSWER ALL TECHNICAL QUESTIONS SUBMITTED PRIOR TO THE DEADLINE FOR TECHNICAL QUESTIONS,		
				2.) EXTEND THE BID OPENING DATE		
				BID OPENING IS EXTENDED TO: 05/19/2009		
				BID OPENING TIME REMAINS: 1:30 PM		
				***** END ADDENDUM NO. 1 *****		
						\$215,000.00

SEE REVERSE SIDE FOR TERMS AND CONDITIONS

SIGNATURE	<i>Robert D. Hill</i>	TELEPHONE	304-632-1600	DATE	5/19/09
TITLE	President	FEIN	55-0648251	ADDRESS CHANGES TO BE NOTED ABOVE	

WHEN RESPONDING TO RFQ, INSERT NAME AND ADDRESS IN SPACE ABOVE LABELED 'VENDOR'

GENERAL TERMS & CONDITIONS REQUEST FOR QUOTATION (RFQ) AND REQUEST FOR PROPOSAL (RFP)

1. Awards will be made in the best interest of the State of West Virginia.
2. The State may accept or reject in part, or in whole, any bid.
3. All quotations are governed by the *West Virginia Code* and the *Legislative Rules* of the Purchasing Division.
4. Prior to any award, the apparent successful vendor must be properly registered with the Purchasing Division and have paid the required \$125 fee.
5. All services performed or goods delivered under State Purchase Order/Contracts are to be continued for the term of the Purchase Order/Contracts, contingent upon funds being appropriated by the Legislature or otherwise being made available. In the event funds are not appropriated or otherwise available for these services or goods, this Purchase Order/Contract becomes void and of no effect after June 30.
6. Payment may only be made after the delivery and acceptance of goods or services.
7. Interest may be paid for late payment in accordance with the *West Virginia Code*.
8. Vendor preference will be granted upon written request in accordance with the *West Virginia Code*.
9. The State of West Virginia is exempt from federal and state taxes and will not pay or reimburse such taxes.
10. The Director of Purchasing may cancel any Purchase Order/Contract upon 30 days written notice to the seller.
11. The laws of the State of West Virginia and the *Legislative Rules* of the Purchasing Division shall govern all rights and duties under the Contract, including without limitation the validity of this Purchase Order/Contract.
12. Any reference to automatic renewal is hereby deleted. The Contract may be renewed only upon mutual written agreement of the parties.
13. **BANKRUPTCY:** In the event the vendor/contractor files for bankruptcy protection, this Contract may be deemed null and void, and terminated without further order.
14. **HIPAA BUSINESS ASSOCIATE ADDENDUM:** The West Virginia State Government HIPAA Business Associate Addendum (BAA), approved by the Attorney General, and available online at the Purchasing Division's web site (<http://www.state.wv.us/admin/purchase/vrc/hipaa.htm>) is hereby made part of the agreement. Provided that, the Agency meets the definition of a Cover Entity (45 CFR §160.103) and will be disclosing Protected Health Information (45 CFR §160.103) to the vendor.
15. **WEST VIRGINIA ALCOHOL & DRUG-FREE WORKPLACE ACT:** If this Contract constitutes a public improvement construction contract as set forth in Article 1D, Chapter 21 of the West Virginia Code ("The West Virginia Alcohol and Drug-Free Workplace Act"), then the following language shall hereby become part of this Contract: "The contractor and its subcontractors shall implement and maintain a written drug-free workplace policy in compliance with the West Virginia Alcohol and Drug-Free Workplace Act, as set forth in Article 1D, Chapter 21 of the West Virginia Code. The contractor and its subcontractors shall provide a sworn statement in writing, under the penalties of perjury, that they maintain a valid drug-free work place policy in compliance with the West Virginia and Drug-Free Workplace Act. It is understood and agreed that this Contract shall be cancelled by the awarding authority if the Contractor: 1) Fails to implement its drug-free workplace policy; 2) Fails to provide information regarding implementation of the contractor's drug-free workplace policy at the request of the public authority; or 3) Provides to the public authority false information regarding the contractor's drug-free workplace policy."

INSTRUCTIONS TO BIDDERS

1. Use the quotation forms provided by the Purchasing Division.
2. **SPECIFICATIONS:** Items offered must be in compliance with the specifications. Any deviation from the specifications must be clearly indicated by the bidder. Alternates offered by the bidder as **EQUAL** to the specifications must be clearly defined. A bidder offering an alternate should attach complete specifications and literature to the bid. The Purchasing Division may waive minor deviations to specifications.
3. Complete all sections of the quotation form.
4. Unit prices shall prevail in case of discrepancy.
5. All quotations are considered F.O.B. destination unless alternate shipping terms are clearly identified in the quotation.
6. **BID SUBMISSION:** All quotations must be delivered by the bidder to the office listed below prior to the date and time of the bid opening. Failure of the bidder to deliver the quotations on time will result in bid disqualifications: Department of Administration, Purchasing Division, 2019 Washington Street East, P.O. Box 50130, Charleston, WV 25305-0130

RFQ#GSD096451**ADA-COMPLIANT RESTROOM RENOVATIONS
BLDG#84 CORNERSTONE****ADDENDUM #1**

Please note that the proper ship-to address of the Request for Quotations is:

WV Department of Administration
General Services Division
Building 84 Cornerstone Bldg
1409 Greenbrier Street
Charleston, WV 25311

Please amend the language of the Request for Quotations, as follows, to clarify the specifications:

1. Page 10 of the RFQ, 5th Sentence: Change “Successful contractor is to remove and install new all ceramic on walls and floors of restrooms” to “Successful contractor is to remove all ceramic tile on floors and walls of restrooms, and install new ceramic on floors of restrooms, with matching bull-nose as specified.”
2. Page 10 of the RFQ, Replace sentence reading “Replaced ceiling tiles must match existing ceiling tiles” with “Replaced ceiling tiles must be Celotex, BET 157 (or equal) with Chicago Fire rated grid system (or equal).” The existing ceiling tile cannot be matched as it is no longer manufactured.
3. Page 14 of the RFQ, under the Material Specifications, OTHER category: change sentence reading “Owner will furnish cove base, paint door framing, install toilet paper holders, towel and soap dispensers, mirrors and door signage” with “Contractor to provide paint for and paint door framing with Pittsburgh Paint DTM Color: Twine (or equal in color, finish and texture). Owner will install toilet paper holders, towel and soap dispensers, mirrors and door signage.”

BID BOND

KNOW ALL MEN BY THESE PRESENTS, That we, the undersigned, Danhill Construction Company
of Gauley Bridge, West Virginia, as Principal, and Colonial Surety Co.
of Montvale, New Jersey, a corporation organized and existing under the laws of the State of NJ
with its principal office in the City of Montvale, as Surety, are held and firmly bound unto the State
of West Virginia, as Obligee, in the penal sum of Twelve Thousand Three Hundred Dollars (\$ 12,300.00) for
the payment of which, well and truly to be made, we jointly and severally bind ourselves, our heirs, administrators, executors,
successors and assigns.

The Condition of the above obligation is such that whereas the Principal has submitted to the Purchasing Section of the
Department of Administration a certain bid or proposal, attached hereto and made a part hereof, to enter into a contract in writing for
ADA Plumbing Renovations for Building 84 Cornerstone.

NOW THEREFORE,

(a) If said bid shall be rejected, or
(b) If said bid shall be accepted and the Principal shall enter into a contract in accordance with the bid or proposal attached
hereto and shall furnish any other bonds and insurance required by the bid or proposal, and shall in all other respects perform the
agreement created by the acceptance of said bid, then this obligation shall be null and void, otherwise this obligation shall remain in full
force and effect. It is expressly understood and agreed that the liability of the Surety for any and all claims hereunder shall, in no event,
exceed the penal amount of this obligation as herein stated.

The Surety, for the value received, hereby stipulates and agrees that the obligations of said Surety and its bond shall be in no
way impaired or affected by any extension of the time within which the Obligee may accept such bid, and said Surety does hereby
waive notice of any such extension.

IN WITNESS WHEREOF, Principal and Surety have hereunto set their hands and seals, and such of them as are corporations
have caused their corporate seals to be affixed hereunto and these presents to be signed by their proper officers, this
19th day of May, 20 09.

Principal Corporate Seal

Danhill Construction Company
(Name of Principal)

By Robert D. Hill
(Must be President or
Vice President)

President Robert D. Hill
(Title)

Surety Corporate Seal

Colonial Surety company
(Name of Surety)

Roberta Bird
Attorney-in-Fact

IMPORTANT – Surety executing bonds must be licensed in West Virginia to transact surety insurance. Raised corporate seals must be affixed, a power of attorney must be attached.

Colonial Surety Company

Administrative Office
50 Chestnut Ridge Road
Montvale, NJ 07645

CONSENT OF SURETY

DOA,GSD, Cornerstone Bldg.
Building 84, Cornerstone Bldg.
Charleston, WV 25305

RE: ADA Plumbing renovations for Bldg. 84 Cornerstone.

COLONIAL SURETY COMPANY organized and existing under the laws of the Commonwealth of Pennsylvania and duly qualified to transact business in the State of WV hereby agrees that

Danhill Construction Company

Glen Ferris, WV

has submitted a proposal on the captioned project. We hereby agree that in the event an award is made to

Danhill Construction Company

Glen Ferris, WV

that we will provide the required performance, payment and/or maintenance bonds.

Signed and sealed this 19th day of May 2009.

COLONIAL SURETY COMPANY

BY: Roberta Bird
Roberta Bird (Attorney-in-Fact)

COLONIAL SURETY COMPANY

Duncannon, Pennsylvania
Administrative Office: 50 Chestnut Ridge Road, Montvale, New Jersey 07645

GENERAL POWER OF ATTORNEY

Know all Men by These Presents, That COLONIAL SURETY COMPANY, a corporation duly organized and existing under the laws of the Commonwealth of Pennsylvania and having an administrative office in Montvale, Bergen County, NJ does by these presents make, constitute and appoint

Glen Ferris WV its true and lawful Attorney(s)-in-Fact, with full power and authority hereby conferred in its name, place and stead, to execute, acknowledge and deliver.

Any and All Bonds

and to bind the Company thereby as fully and to the same extent as if such bonds were signed by the President, sealed with the corporate seal of the Company and duly attested by its Secretary, hereby ratifying and confirming all that the said Attorney(s)-in-Fact may do in the premises.

Be it Resolved, that the President, any Vice-President, any Secretary or any Assistant Secretary shall be and is hereby vested with full power and authority to appoint any one or more suitable persons as Attorney(s)-in-Fact to represent and act for and on behalf of the Company subject to the following provisions:

Section I. Attorney-in-Fact. Attorney-in-Fact may be given full power and authority for and in the name of and on behalf of the Company, to execute, acknowledge and deliver, any and all bonds, recognizances, contracts, agreements of indemnity and other conditional or obligatory undertakings and any and all notices and documents canceling or terminating the Company's liability thereunder, and any such instruments so executed by any such Attorney-in-Fact shall be binding upon the Company as if signed by the President and sealed and attested by the Corporate Secretary.

In Witness Whereof, Colonial Surety Company has caused these presents to be signed by its President and its corporate seal to be hereto affixed the 8th day of September, A.D., 2006.

State of New Jersey
County of Bergen
} SS.:



COLONIAL SURETY COMPANY

By Wayne Nunziata, President

On this 8th day of September, in the year 2006, before me Theresa Simmons, a notary public, personally appeared Wayne Nunziata, personally known to me to be the person who executed the within instrument as President, on behalf of the corporation therein named and acknowledged to me that the corporation executed it.



THERESA SIMMONS
A Notary Public of New Jersey
My Commission Expires September 2, 2010

Theresa Simmons
Notary Public

I, the undersigned Secretary of Colonial Surety Company, hereby certify that the above and foregoing is a full, true and correct copy of the Original Power of Attorney issued by said Company, and do hereby further certify that the said Power of Attorney is still in force and effect.

And I do hereby further certify that the Certification of this Power of Attorney is signed and sealed by facsimile under and by the authority of the following resolution adopted by the Board of Directors of the Colonial Surety Company at a meeting duly called and held on the 30th of January 1968, and that said resolution has not been amended or repealed:

RESOLVED, that the signature of the Secretary or any Assistant Secretary of this Corporation, and the seal of Corporation, may be affixed or printed by facsimile to any certificate to a Power of Attorney of this Corporation, and that such printed facsimile signature and seal shall be valid and binding upon this Corporation.

GIVEN under my hand and the seal of said Company, at Montvale, New Jersey this 19th day of May, 20 09.

For verification of the authenticity of this Power of Attorney you may call (201) 573-8788 and ask for the Power of Attorney clerk. Please refer to the above named individual(s) and details of the bond to which the power is attached.

Frederick S. Gallo, Secretary

State of West Virginia

County of Fayette

AND NOW, this 19th day of May, in the calendar year of 2009, before me, a duly appointed and commissioned notary public, came the identified subscriber to the within instrument or instruments, and/or the demonstrated attorney-in-fact for said signatory and subscriber on said instrument or instruments, **Roberta Bird, attorney-in-fact of Colonial Surety Company**, an insurance company duly organized and existing under the laws of the Commonwealth of Pennsylvania and which is authorized to conduct business in this State, and that as such being authorized to do so, acknowledged that the within instrument or instruments were executed as the authorized act of his disclosed principal for the purposes therein contained, and declared to be a person executing said instrument or instruments as attorney-in-fact and with full capacity and competency, at the request of and on behalf of Colonial Surety Company therein named and acknowledged to me that the aforesaid Colonial Surety Company had authorized the execution by the aforesaid attorney-in-fact of said instrument or instruments with the intent to be legally bound as required by common and statutory law.

IN WITNESS WHEREOF, I hereunto set my hand and official seal.

A Notary Public of West Virginia
My Commission Expires on 2/28/2015

Notary Public in and for the

County of Fayette
State of West Virginia

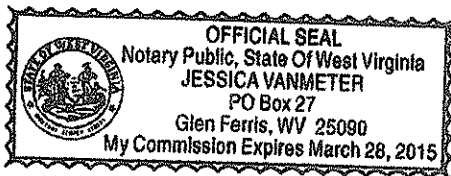

Jessica VanMeter
NOTARY PUBLIC



PRODUCER:

BrickStreet Mutual Insurance Company
400 Quarrier Street
Charleston, WV 25301

CERTIFICATE HOLDER:

DANHILL CONSTRUCTION COMPANY
PO BOX 685
GAULEY BRIDGE, WEST VIRGINIA 25085-0685

INSURED:

DANHILL CONSTRUCTION COMPANY
PO BOX 685
GAULEY BRIDGE, WEST VIRGINIA 25085-0685

CERTIFICATE OF INSURANCE

The policy of insurance listed below has been issued to the insured named above for the policy period and coverage indicated. This certificate is issued as a matter of information only and confers no rights upon the certificate holder. This certificate does not amend, extend or alter the coverage afforded by the policy below. Coverage is contingent on the insured's compliance with policy conditions and premium payment.

If the policy is canceled before the expiration date, BrickStreet Mutual Insurance Company will endeavor to mail a written notice to the certificate holder within 30 days of cancelation. Failure to mail the notice shall impose no obligation or liability of any kind upon BrickStreet Mutual Insurance Company.

POLICY NUMBER: WC10009090-05

DATE CERTIFICATE ISSUED: 09/02/2008

POLICY EFFECTIVE DATE: 08/28/2008

EXPIRATION DATE: 08/28/2009

WORKERS COMPENSATION AND EMPLOYERS LIABILITY

LIMITS / COVERAGE

WORKERS COMPENSATION - STATUTORY LIMITS

EMPLOYERS LIABILITY LIMITS:

BODILY INJURY BY ACCIDENT:	\$ 100,000.00	EACH ACCIDENT
BODILY INJURY BY DISEASE:	\$ 500,000.00	POLICY LIMIT
BODILY INJURY BY DISEASE:	\$ 100,000.00	EACH EMPLOYEE

**WV BROAD FORM EMPLOYERS LIABILITY ENDORSEMENT -
COVERAGE FOR WV CODE 23-4-2(d)(2)(ii)**

**FEDERAL COAL MINE HEALTH AND SAFETY ACT COVERAGE ENDORSEMENT -
COVERAGE FOR WV CODE 23-4b-1 - FEDERAL BLACK LUNG COVERAGE**

SPECIAL PROVISIONS IF ANY:

ACORD CERTIFICATE OF LIABILITY INSURANCE

DATE (MM/DD/YYYY)
5/7/2008

PRODUCER (304)720-2000 FAX: (304)720-2002
Mountain State Insurance Agency
1206 Kanawha Blvd. E.

THIS CERTIFICATE IS ISSUED AS A MATTER OF INFORMATION ONLY AND CONFERS NO RIGHTS UPON THE CERTIFICATE HOLDER. THIS CERTIFICATE DOES NOT AMEND, EXTEND OR ALTER THE COVERAGE AFFORDED BY THE POLICIES BELOW.

Charleston WV 25301

INSURERS AFFORDING COVERAGE

NAIC #

INSURED

INSURER A: Westfield

24112

DanHill Construction Company (Inc.)
Box 685

INSURER B:

INSURER C:

INSURER D:

Gauley Bridge WV 25085

INSURER E:

COVERAGES

THE POLICIES OF INSURANCE LISTED BELOW HAVE BEEN ISSUED TO THE INSURED NAMED ABOVE FOR THE POLICY PERIOD INDICATED. NOTWITHSTANDING ANY REQUIREMENT, TERM OR CONDITION OF ANY CONTRACT OR OTHER DOCUMENT WITH RESPECT TO WHICH THIS CERTIFICATE MAY BE ISSUED OR MAY PERTAIN, THE INSURANCE AFFORDED BY THE POLICIES DESCRIBED HEREIN IS SUBJECT TO ALL THE TERMS, EXCLUSIONS AND CONDITIONS OF SUCH POLICIES. AGGREGATE LIMITS SHOWN MAY HAVE BEEN REDUCED BY PAID CLAIMS.

INSR	ADD'L	TYPE OF INSURANCE	POLICY NUMBER	POLICY EFFECTIVE DATE (MM/DD/YY)	POLICY EXPIRATION DATE (MM/DD/YY)	LIMITS
A		GENERAL LIABILITY	CWP3808332	5/24/2008	5/24/2009	EACH OCCURRENCE \$ 1,000,000
		<input checked="" type="checkbox"/> COMMERCIAL GENERAL LIABILITY <input type="checkbox"/> CLAIMS MADE <input checked="" type="checkbox"/> OCCUR GEN'L AGGREGATE LIMIT APPLIES PER: <input checked="" type="checkbox"/> POLICY <input type="checkbox"/> PRO-JECT <input type="checkbox"/> LOC				DAMAGE TO RENTED PREMISES (Ea occurrence) \$ 300,000 MED EXP (Any one person) \$ 10,000 PERSONAL & ADV INJURY \$ 1,000,000 GENERAL AGGREGATE \$ 2,000,000 PRODUCTS - COMP/OP AGG \$ 2,000,000
A		AUTOMOBILE LIABILITY	CWP3808332	5/24/2008	5/24/2009	COMBINED SINGLE LIMIT (Ea accident) \$ 1,000,000
		<input checked="" type="checkbox"/> ANY AUTO <input type="checkbox"/> ALL OWNED AUTOS <input type="checkbox"/> SCHEDULED AUTOS <input type="checkbox"/> HIRED AUTOS <input type="checkbox"/> NON-OWNED AUTOS				BODILY INJURY (Per person) \$ BODILY INJURY (Per accident) \$ PROPERTY DAMAGE (Per accident) \$
		GARAGE LIABILITY				AUTO ONLY - EA ACCIDENT \$
		<input type="checkbox"/> ANY AUTO				OTHER THAN EA ACC \$ AUTO ONLY: AGG \$
A		EXCESS/UMBRELLA LIABILITY	CWP3808332	5/24/2008	5/24/2009	EACH OCCURRENCE \$ 5,000,000
		<input type="checkbox"/> OCCUR <input type="checkbox"/> CLAIMS MADE <input type="checkbox"/> DEDUCTIBLE <input checked="" type="checkbox"/> RETENTION \$ 0				AGGREGATE \$ 5,000,000 \$ \$
A		WORKERS COMPENSATION AND EMPLOYERS' LIABILITY ANY PROPRIETOR/PARTNER/EXECUTIVE OFFICER/MEMBER EXCLUDED? If yes, describe under SPECIAL PROVISIONS below	CWP3808332	5/24/2008	5/24/2009	WC STATU-TORY LIMITS OTH-ER
						E.L. EACH ACCIDENT \$ 1,000,000
						E.L. DISEASE - EA EMPLOYEE \$ 1,000,000 E.L. DISEASE - POLICY LIMIT \$ 1,000,000
		OTHER				

DESCRIPTION OF OPERATIONS/LOCATIONS/VEHICLES/EXCLUSIONS ADDED BY ENDORSEMENT/SPECIAL PROVISIONS

This certificate is only for proof of insurance. This certificate does not confer on or extend insurance coverage to any recipient. This certificate does not amend any insurance coverages. All insurance coverages are subject to the policy terms and conditions.

CERTIFICATE HOLDER

For Insurance Purposes Only

CANCELLATION

SHOULD ANY OF THE ABOVE DESCRIBED POLICIES BE CANCELLED BEFORE THE EXPIRATION DATE THEREOF, THE ISSUING INSURER WILL ENDEAVOR TO MAIL 30 DAYS WRITTEN NOTICE TO THE CERTIFICATE HOLDER NAMED TO THE LEFT, BUT FAILURE TO DO SO SHALL IMPOSE NO OBLIGATION OR LIABILITY OF ANY KIND UPON THE INSURER, ITS AGENTS OR REPRESENTATIVES.

AUTHORIZED REPRESENTATIVE

Darlene Payne/DARLEN



CONTRACTOR LICENSE

Authorized by the

West Virginia Contractor Licensing Board

Number: WV001196

Classification:

ELECTRICAL
GENERAL BUILDING
HEATING, VENTILATING & COOLING
MULTIFAMILY
PIPING
PLUMBING
RESIDENTIAL

DANHILL CONSTRUCTION COMPANY
PO BOX 685
GAULEY BRIDGE, WV 25085-0685

Date Issued

AUGUST 06, 2008

Expiration Date

AUGUST 06, 2009

Authorized Company Signature

Chair, West Virginia Contractor
Licensing Board



**WEST VIRGINIA
CONTRACTOR
LICENSING
BOARD**

This license, or a copy thereof, must be posted in a conspicuous place at every construction site where work is being performed. This license number must appear in all advertisements, on all bid submissions and on all fully executed and binding contracts. This license cannot be assigned or transferred by licensee. Issued under provisions of West Virginia Code, Chapter 21, Article 11.