



State of West Virginia
 Department of Administration
 Purchasing Division
 2019 Washington Street East
 Post Office Box 50130
 Charleston, WV 25305-0130

Request for Quotation

RFQ NUMBER
EDD310043

PAGE
1

ADDRESS CORRESPONDENCE TO ATTENTION OF
**SHELLY MURRAY
 304-558-8801**

DEPARTMENT OF EDUCATION
 BUILDING 6
 1900 KANAWHA BOULEVARD, EAST
 CHARLESTON, WV
 25305-0330

*709045414 304-424-7353
 KELLY PAVING INC
 PO BOX 366
 WILLIAMSTOWN WV 26187

KELLY PAVING INC

KELLY PAVING INC

DATE PRINTED	TERMS OF SALE	SHIP VIA	F.O.B.	FREIGHT TERMS
01/12/2009				

BID OPENING DATE: **02/11/2009** BID OPENING TIME **01:30PM**

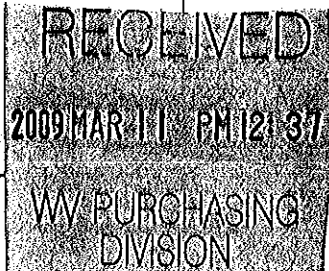
LINE	QUANTITY	UOP	CAT. NO.	ITEM NUMBER	UNIT PRICE	AMOUNT
0001	1	LS		968-42		
<p>THE WV PURCHASING DIVISION, FOR THE AGENCY, THE WV DEPARTMENT OF EDUCATION, IS SOLICITING BIDS TO PROVIDE PAVING CONSTRUCTION SERVICES.</p> <p>A MANDATORY PRE-BID CONFERENCE WILL BE HELD ON 1/27/09 AT 10:00 AM AT THE CEDAR LAKES CONFERENCE CENTER, RIPLEY, WV. ALL VENDORS INTERESTED IN SUBMITTING A BID FOR THIS PROJECT MUST ATTEND THIS MEETING. ANY VENDOR FAILING TO ATTEND WILL BE DISQUALIFIED. NO ONE PERSON MAY REPRESENT MORE THAN ONE VENDOR.</p> <p>TECHNICAL QUESTIONS MUST BE SUBMITTED IN WRITING TO SHELLY MURRAY IN THE WV PURCHASING DIVISION VIA MAIL, AT THE ADDRESS SHOWN AT THE TOP OF THIS RFQ, VIA FAX AT 304-558-4115, OR VIA EMAIL AT SHELLY.L.MURRAY@WV.GOV. DEADLINE FOR ALL TECHNICAL QUESTIONS IS 1/29/2009 AT THE CLOSE OF BUSINESS. ALL TECHNICAL QUESTIONS RECEIVED, IN ANY, WILL BE ADDRESSED BY ADDENDUM AFTER THE DEADLINE.</p> <p>QUESTIONS CONCERNING THE ACTUAL PROCESS BY WHICH A VENDOR MAY SUBMIT A BID TO THE STATE OF WV ARE NOT CONSIDERED TO BE TECHNICAL QUESTIONS AND MAY BE SUBMITTED AT ANY TIME PRIOR TO THE RFQ OPENING DATE AND IN ANY FORMAT.</p>						
						

SEE REVERSE SIDE FOR TERMS AND CONDITIONS

SIGNATURE <i>Roger Thomas</i>	TELEPHONE 304-424-7353	DATE 2/25/09
TITLE Area Manager	FEIN 55-0583614	ADDRESS CHANGES TO BE NOTED ABOVE

WHEN RESPONDING TO RFQ, INSERT NAME AND ADDRESS IN SPACE ABOVE LABELED 'VENDOR'



State of West Virginia
 Department of Administration
 Purchasing Division
 2019 Washington Street East
 Post Office Box 50130
 Charleston, WV 25305-0130

Request for Quotation

RFQ NUMBER
EDD310043

PAGE
2

ADDRESS CORRESPONDENCE TO ATTENTION OF
**SHELLY MURRAY
 304-558-8801**

***709045414 304-424-7353**
KELLY PAVING INC
PO BOX 366

WILLIAMSTOWN WV 26187

DEPARTMENT OF EDUCATION

BUILDING 6
1900 KANAWHA BOULEVARD, EAST
CHARLESTON, WV
25305-0330

DATE PRINTED	TERMS OF SALE	SHIP VIA	FOB	FREIGHT TERMS
01/12/2009				

BID OPENING DATE: **02/11/2009** BID OPENING TIME **01:30PM**

LINE	QUANTITY	UOP	CAT NO	ITEM NUMBER	UNIT PRICE	AMOUNT
<p>EXHIBIT 5</p> <p>WEST VIRGINIA CODE 21-1D-5 PROVIDES THAT: ANY SOLICITATION FOR A PUBLIC IMPROVEMENT CONSTRUCTION CONTRACT REQUIRES EACH VENDOR THAT SUBMITS A BID FOR THE WORK TO SUBMIT AT THE SAME TIME AN AFFIDAVIT OF COMPLIANCE WITH THE BID. THE ENCLOSED PURCHASING AFFIDAVIT MUST BE SIGNED AND SUBMITTED WITH THE BID AS EVIDENCE OF THE VENDOR'S COMPLIANCE WITH THE PROVISIONS OF ARTICLE 1D, CHAPTER 21 OF THE WEST VIRGINIA CODE. FAILURE TO SUBMIT THE SIGNED PURCHASING AFFIDAVIT WITH THE BID SHALL RESULT IN DISQUALIFICATION OF SUCH BID.</p> <p>NOTICE TO PROCEED: THIS CONTRACT IS TO BE PERFORMED WITHIN 180 CALENDAR DAYS AFTER THE NOTICE TO PROCEED IS RECEIVED. UNLESS OTHERWISE SPECIFIED, THE FULLY EXECUTED PURCHASE ORDER WILL BE CONSIDERED NOTICE TO PROCEED.</p> <p>CANCELLATION: THE DIRECTOR OF PURCHASING RESERVES THE RIGHT TO CANCEL THIS CONTRACT IMMEDIATELY UPON WRITTEN NOTICE TO THE VENDOR IF THE MATERIALS OR WORKMANSHIP SUPPLIED ARE OF AN INFERIOR QUALITY OR DO NOT CONFORM WITH THE SPECIFICATIONS OF THE BID AND CONTRACT HERE IN.</p> <p>WAGE RATES: THE CONTRACTOR OR SUBCONTRACTOR SHALL PAY THE HIGHER OF THE U.S. DEPARTMENT OF LABOR MINIMUM WAGE RATES AS ESTABLISHED FOR JACKSON COUNTY, PURSUANT TO WEST VIRGINIA CODE 21-5A, ET, SEQ. (PREVAILING WAGE RATES APPLY TO THIS PROJECT)</p> <p>ARBITRATION: ANY REFERENCES MADE TO ARBITRATION OR INTEREST FOR PAYMENTS DUE (EXCEPT FOR ANY INTEREST REQUIRED BY STATE LAW) CONTAINED IN THIS CONTRACT OR IN ANY AMERICAN INSTITUTE OF ARCHITECTS DOCUMENTS</p>						

SEE REVERSE SIDE FOR TERMS AND CONDITIONS

SIGNATURE <i>Roger Thomas</i>	TELEPHONE 304-424-7353	DATE 2/25/09
TITLE Area Manager	FEIN 55-0583614	ADDRESS CHANGES TO BE NOTED ABOVE

WHEN RESPONDING TO RFQ, INSERT NAME AND ADDRESS IN SPACE ABOVE LABELED 'VENDOR'



State of West Virginia
 Department of Administration
 Purchasing Division
 2019 Washington Street East
 Post Office Box 50130
 Charleston, WV 25305-0130

Request for Quotation

RFQ NUMBER
EDD310043

PAGE
3

ADDRESS CORRESPONDENCE TO ATTENTION OF
**SHELLY MURRAY
 304-558-8801**

*709045414 304-424-7353
**KELLY PAVING INC
 PO BOX 366
 WILLIAMSTOWN WV 26187**

**DEPARTMENT OF EDUCATION
 BUILDING 6
 1900 KANAWHA BOULEVARD, EAST
 CHARLESTON, WV
 25305-0330**

VENDOR

SHIP TO

DATE PRINTED	TERMS OF SALE	SHIP VIA	F.O.B.	FREIGHT TERMS
01/12/2009				

BID OPENING DATE: **02/11/2009** BID OPENING TIME **01:30PM**

LINE	QUANTITY	UOP	CAT NO	ITEM NUMBER	UNIT PRICE	AMOUNT
<p>PERTAINING TO THIS CONTRACT ARE HEREBY DELETED.</p> <p>WORKERS' COMPENSATION: VENDOR IS REQUIRED TO PROVIDE A CERTIFICATE FROM WORKERS' COMPENSATION IF SUCCESSFUL.</p> <p>ALL OF THE ITEMS CHECKED BELOW WILL BE A REQUIREMENT OF THIS CONTRACT:</p> <p>(XX) INSURANCE: SUCCESSFUL VENDOR SHALL FURNISH PROOF OF COMMERCIAL GENERAL LIABILITY INSURANCE PRIOR TO ISSUANCE OF CONTRACT. UNLESS OTHERWISE SPECIFIED IN THE BID DOCUMENTS, THE MINIMUM AMOUNT OF INSURANCE COVERAGE REQUIRED IS \$250,000.</p> <p>() BUILDERS RISK INSURANCE: SUCCESSFUL VENDOR SHALL FURNISH PROOF OF BUILDERS RISK - ALL RISK INSURANCE IN AN AMOUNT EQUAL TO 100% OF THE AMOUNT OF THE CONTRACT.</p> <p>(XX) BONDS: FIVE PERCENT (5%) OF THE TOTAL AMOUNT OF THE BID PAYABLE TO THE STATE OF WEST VIRGINIA, SHALL BE SUBMITTED WITH EACH BID AS A BID BOND. THE SUCCESSFUL BIDDER SHALL ALSO FURNISH A PERFORMANCE BOND AND LABOR/MATERIAL BOND FOR 100% OF THE AMOUNT OF THE CONTRACT. BONDS MAY BE PROVIDED IN THE FORM OF A CERTIFIED CHECK IRREVOCABLE LETTER OF CREDIT, OR BOND FURNISHED BY A SOLVENT SURETY COMPANY AUTHORIZED TO DO BUSINESS IN THE STATE OF WEST VIRGINIA. A LETTER OF CREDIT SUBMITTED IN LIEU OF A BOND WILL ONLY BE ALLOWED FOR PROJECTS UNDER \$100,000. PERSONAL OR BUSINESS CHECKS ARE NOT ACCEPABLE IN LIEU OF THE 5% BID BOND, PERFORMANCE BOND, OR LABOR AND MATERIAL BOND.</p> <p>() MAINTENANCE BOND: A TWO (2) YEAR MAINTENANCE BOND COVERING THE ROOFING SYSTEM WILL BE A REQUIREMENT OF THE SUCCESSFUL VENDOR.</p>						

SEE REVERSE SIDE FOR TERMS AND CONDITIONS

SIGNATURE <i>Roger Thomas</i>	TELEPHONE 304-424-7353	DATE 2/25/09
TITLE Area Manager	FEIN 55-0583614	ADDRESS CHANGES TO BE NOTED ABOVE

WHEN RESPONDING TO RFQ, INSERT NAME AND ADDRESS IN SPACE ABOVE LABELED 'VENDOR'



State of West Virginia
 Department of Administration
 Purchasing Division
 2019 Washington Street East
 Post Office Box 50130
 Charleston, WV 25305-0130

Request for Quotation

RFO NUMBER
EDD310043

PAGE
5

ADDRESS CORRESPONDENCE TO ATTENTION OF
**SHELLY MURRAY
 304-558-8801**

*709045414 304-424-7353
**KELLY PAVING INC
 PO BOX 366
 WILLIAMSTOWN WV 26187**

**DEPARTMENT OF EDUCATION
 BUILDING 6
 1900 KANAWHA BOULEVARD, EAST
 CHARLESTON, WV
 25305-0330**

DATE PRINTED	TERMS OF SALE	SHIP VIA	F.O.B.	FREIGHT TERMS
01/12/2009				

BID OPENING DATE: **02/11/2009** BID OPENING TIME **01:30PM**

LINE	QUANTITY	UQP	CAT NO	ITEM NUMBER	UNIT PRICE	AMOUNT
<p>ALUMINUM, GLASS OR STEEL THAT IS REASONABLE AND LOWER THAN THE LOWEST BID DOMESTIC PRODUCTS, THE SPENDING OFFICE MAY REQUEST, IN WRITING, A REEVALUATION AND REDUCTION IN THE LOWEST BID FOR SUCH DOMESTIC PRODUCTS. ALL VENDORS MUST INDICATE IN THEIR BID IF THEY ARE SUPPLYING FOREIGN ALUMINUM, GLASS OR STEEL.</p> <p>REV. 3/88</p> <p>EXHIBIT 9</p> <p>NOTICE FOR ISSUANCE & ACKNOWLEDGEMENT OF CONSTRUCTION PROJECT ADDENDA</p> <p>THE ARCHITECT/ENGINEER AND/OR AGENCY SHALL BE REQUIRED TO ABIDE BY THE FOLLOWING SCHEDULE IN ISSUING CONSTRUCTION PROJECT ADDENDA FOR STATE AGENCIES:</p> <p>(1) THE ARCHITECT/ENGINEER SHALL PREPARE THE ADDENDUM AND A LIST OF ALL PARTIES THAT HAVE PROCURED DRAWINGS AND SPECIFICATIONS FOR THE PROJECT. THE ADDENDUM AND LIST SHALL BE FORWARDED TO THE BUYER IN THE STATE PURCHASING DIVISION. THE ARCHITECT/ENGINEER SHALL ALSO SEND A COPY OF THE ADDENDUM TO THE STATE AGENCY FOR WHICH THE CONTRACT IS ISSUED.</p> <p>(2) THE BUYER SHALL SEND THE ADDENDUM TO ALL INTERESTED PARTIES AND, IF NECESSARY, EXTEND THE BID OPENING DATE. ANY ADDENDUM SHOULD BE RECEIVED BY THE BUYER WITHIN FOURTEEN (14) DAYS PRIOR TO THE BID OPENING DATE.</p> <p>(3) ALL ADDENDA SHOULD BE FORMALLY ACKNOWLEDGED BY ALL BIDDERS AND SUBMITTED TO THE STATE PURCHASING DIVISION. THE SAME RULES AND REGULATIONS</p>						

SEE REVERSE SIDE FOR TERMS AND CONDITIONS

SIGNATURE <i>Roger Thomas</i>	TELEPHONE 304-424-7353	DATE 2/25/09
TITLE Area Manager	FEIN 55-0583614	ADDRESS CHANGES TO BE NOTED ABOVE

WHEN RESPONDING TO RFQ, INSERT NAME AND ADDRESS IN SPACE ABOVE LABELED 'VENDOR'



State of West Virginia
 Department of Administration
 Purchasing Division
 2019 Washington Street East
 Post Office Box 50130
 Charleston, WV 25305-0130

Request for Quotation

RFO NUMBER
EDD310043

PAGE
6

ADDRESS CORRESPONDENCE TO ATTENTION OF
**SHELLY MURRAY
 304-558-8801**

RECEIVED

*709045414 304-424-7353
**KELLY PAVING INC
 PO BOX 366
 WILLIAMSTOWN WV 26187**

SHIP TO

**DEPARTMENT OF EDUCATION
 BUILDING 6
 1900 KANAWHA BOULEVARD, EAST
 CHARLESTON, WV
 25305-0330**

DATE PRINTED	TERMS OF SALE	SHIP VIA	F.O.B.	FREIGHT TERMS
01/12/2009				

BID OPENING DATE: **02/11/2009** BID OPENING TIME **01:30PM**

LINE	QUANTITY	UOP	CAT. NO.	ITEM NUMBER	UNIT PRICE	AMOUNT
				<p>THAT APPLY TO THE ORIGINAL BIDDING DOCUMENT SHALL ALSO APPLY TO AN ADDENDUM DOCUMENT. THE ONLY EXCEPTION MAY BE FOR AN ADDENDUM THAT IS ISSUED FOR THE SOLE PURPOSE OF CHANGING A BID OPENING TIME AND/OR DATE.</p> <p>REV. 11/96</p> <p>EXHIBIT 10</p> <p>ADDENDUM ACKNOWLEDGEMENT</p> <p>I HEREBY ACKNOWLEDGE RECEIPT OF THE FOLLOWING CHECKED ADDENDUM(S) AND HAVE MADE THE NECESSARY REVISIONS TO MY PROPOSAL, PLANS AND/OR SPECIFICATION, ETC.</p> <p>ADDENDUM NOS.:</p> <p>NO. 1 ..X.....</p> <p>NO. 2 ..X.....</p> <p>NO. 3 ..X.....</p> <p>NO. 4 ..X.....</p> <p>NO. 5 ..X.....</p> <p>I UNDERSTAND THAT FAILURE TO CONFIRM THE RECEIPT OF TH ADDENDUM(S) MAY BE CAUSE FOR REJECTION OF THE BIDS.</p> <p>VENDOR MUST CLEARLY UNDERSTAND THAT ANY VERBAL REPRESENTATION MADE OR ASSUMED TO BE MADE DURING ANY ORAL DISCUSSION HELD BETWEEN VENDOR'S REPRESENTATIVES AND ANY STATE PERSONNEL IS NOT BINDING. ONLY THE</p>		

SEE REVERSE SIDE FOR TERMS AND CONDITIONS

SIGNATURE <i>Roger Thomas</i>	TELEPHONE 304-424-7353	DATE 2/25/09
TITLE Area Manager	FEIN 55-0583614	ADDRESS CHANGES TO BE NOTED ABOVE

WHEN RESPONDING TO RFQ, INSERT NAME AND ADDRESS IN SPACE ABOVE LABELED 'VENDOR'



State of West Virginia
 Department of Administration
 Purchasing Division
 2019 Washington Street East
 Post Office Box 50130
 Charleston, WV 25305-0130

Request for Quotation

RFQ NUMBER
EDD310043

PAGE
7

ADDRESS CORRESPONDENCE TO ATTENTION OF
**SHELLY MURRAY
 304-558-8801**

*709045414 304-424-7353
**KELLY PAVING INC
 PO BOX 366**

WILLIAMSTOWN WV 26187

DEPARTMENT OF EDUCATION

**BUILDING 6
 1900 KANAWHA BOULEVARD, EAST
 CHARLESTON, WV
 25305-0330**

SHIP TO

SHIP TO

DATE PRINTED	TERMS OF SALE	SHIP VIA	F.O.B.	FREIGHT TERMS
01/12/2009				

BID OPENING DATE: **02/11/2009** BID OPENING TIME **01:30PM**

LINE	QUANTITY	UOP	CAT NO	ITEM NUMBER	UNIT PRICE	AMOUNT
<p>INFORMATION ISSUED IN WRITING AND ADDED TO THE SPECIFICATIONS BY AN OFFICIAL ADDENDUM IS BINDING.</p> <p><i>Roger Thomas</i> SIGNATURE</p> <p>..... Kelly Paving, INC. COMPANY</p> <p>..... 2/25/09 DATE</p> <p>REV. 11/96</p> <p style="text-align: center;">CONTRACTORS LICENSE</p> <p>WEST VIRGINIA STATE CODE 21-11-2 REQUIRES THAT ALL PERSONS DESIRING TO PERFORM CONTRACTING WORK IN THIS STATE MUST BE LICENSED. THE WEST VIRGINIA CONTRACTORS LICENSING BOARD IS EMPOWERED TO ISSUE THE CONTRACTORS LICENSE. APPLICATIONS FOR A CONTRACTORS LICENSE MAY BE MADE BY CONTACTING THE WEST VIRGINIA DIVISION OF LABOR CAPITOL COMPLEX, BUILDING 3, ROOM 319, CHARLESTON, WV 25305. TELEPHONE: (304) 558-7890.</p> <p>WEST VIRGINIA STATE CODE 21-11-11 REQUIRES ANY PROSPECTIVE BIDDER TO INCLUDE THE CONTRACTORS LICENSE NUMBER ON THEIR BID.</p> <p>BIDDER TO COMPLETE:</p> <p>CONTRACTORS NAME: Kelly Paving, Inc.</p> <p>CONTRACTORS LICENSE NO.: WV001884</p> <p>THE SUCCESSFUL BIDDER WILL BE REQUIRED TO FURNISH A COPY OF THEIR CONTRACTORS LICENSE PRIOR TO ISSUANCE OF</p>						

SEE REVERSE SIDE FOR TERMS AND CONDITIONS

SIGNATURE <i>Roger Thomas</i>	TELEPHONE 304-424-7353	DATE 2/25/09
TITLE Area Manager	FEIN 55-0583614	ADDRESS CHANGES TO BE NOTED ABOVE

WHEN RESPONDING TO RFQ, INSERT NAME AND ADDRESS IN SPACE ABOVE LABELED 'VENDOR'



State of West Virginia
 Department of Administration
 Purchasing Division
 2019 Washington Street East
 Post Office Box 50130
 Charleston, WV 25305-0130

Request for Quotation

RFQ NUMBER
EDD310043

PAGE
8

ADDRESS CORRESPONDENCE TO ATTENTION OF
SHELLY MURRAY 304-558-8801

PURCHASING

*709045414 304-424-7353
 KELLY PAVING INC
 PO BOX 366
 WILLIAMSTOWN WV 26187

SHIP TO

DEPARTMENT OF EDUCATION
 BUILDING 6
 1900 KANAWHA BOULEVARD, EAST
 CHARLESTON, WV
 25305-0330

DATE PRINTED	TERMS OF SALE	SHIP VIA	F.O.B.	FREIGHT TERMS
01/12/2009				

BID OPENING DATE: 02/11/2009 BID OPENING TIME 01:30PM

LINE	QUANTITY	UOP	CAT NO	ITEM NUMBER	UNIT PRICE	AMOUNT
<p>A PURCHASE ORDER/CONTRACT</p> <p>APPLICABLE LAW</p> <p>THE WEST VIRGINIA STATE CODE, PURCHASING DIVISION RULES AND REGULATIONS, AND THE INFORMATION PROVIDED IN THE "REQUEST FOR QUOTATION" ISSUED BY THE PURCHASING DIVISION IS THE SOLE AUTHORITY GOVERNING THIS PROCUREMENT.</p> <p>ANY INFORMATION PROVIDED IN SPECIFICATION MANUALS, OR ANY OTHER SOURCE, VERBAL OR WRITTEN, WHICH CONTRADICTS OR ALTERS THE INFORMATION PROVIDED FROM THE SOURCES AS DESCRIBED IN THE ABOVE PARAGRAPH IS VOID AND OF NO EFFECT.</p> <p>BANKRUPTCY: IN THE EVENT THE VENDOR/CONTRACTOR FILES FOR BANKRUPTCY PROTECTION, THIS CONTRACT IS AUTOMATICALLY NULL AND VOID, AND IS TERMINATED WITHOUT FURTHER ORDER.</p> <p>REV. 1/2005</p> <p>NOTICE</p> <p>A SIGNED BID MUST BE SUBMITTED TO:</p> <p>DEPARTMENT OF ADMINISTRATION PURCHASING DIVISION BUILDING 15 2019 WASHINGTON STREET, EAST CHARLESTON, WV 25305-0130</p> <p>THE BID SHOULD CONTAIN THIS INFORMATION ON THE FACE OF</p>						

SEE REVERSE SIDE FOR TERMS AND CONDITIONS

SIGNATURE <i>Roger Thomas</i>	TELEPHONE 304-424-7353	DATE 2/25/09
TITLE Area Manager	FEIN 55-0583614	ADDRESS CHANGES TO BE NOTED ABOVE

WHEN RESPONDING TO RFQ, INSERT NAME AND ADDRESS IN SPACE ABOVE LABELED 'VENDOR'



State of West Virginia
 Department of Administration
 Purchasing Division
 2019 Washington Street East
 Post Office Box 50130
 Charleston, WV 25305-0130

Request for Quotation

RFO NUMBER
EDD310043

PAGE
9

ADDRESS CORRESPONDENCE TO ATTENTION OF
**SHELLY MURRAY
 304-558-8801**

***709045414 304-424-7353**
KELLY PAVING INC
PO BOX 366
WILLIAMSTOWN WV 26187

DEPARTMENT OF EDUCATION
BUILDING 6
1900 KANAWHA BOULEVARD, EAST
CHARLESTON, WV
25305-0330

DATE PRINTED	TERMS OF SALE	SHIP VIA	FOB	FREIGHT TERMS
01/12/2009				

BID OPENING DATE: **02/11/2009** BID OPENING TIME **01:30PM**

LINE	QUANTITY	UOP	CAT NO	ITEM NUMBER	UNIT PRICE	AMOUNT
<p>THE ENVELOPE OR THE BID MAY NOT BE CONSIDERED: SEALED BID</p> <p>BUYER: SHELLY MURRAY</p> <p>REQ. NO.: EDD310043</p> <p>BID OPENING DATE: 02/11/2009</p> <p>BID OPENING TIME: 1:30 PM</p> <p>PLEASE PROVIDE A FAX NUMBER IN CASE IT IS NECESSARY TO CONTACT YOU REGARDING YOUR BID: 740-373-6505</p> <p>-----</p> <p>PLEASE PRINT OR TYPE NAME OF PERSON TO CONTACT CONCERNING THIS QUOTE: Tom Williams</p> <p>-----</p> <p>***** THIS IS THE END OF RFQ EDD310043 ***** TOTAL: _____</p>						

SEE REVERSE SIDE FOR TERMS AND CONDITIONS

SIGNATURE <i>Roger Thomas</i>	TELEPHONE 304-424-7353	DATE 2/25/09
TITLE Area Manager	FEIN 55-0583614	ADDRESS CHANGES TO BE NOTED ABOVE

WHEN RESPONDING TO RFQ, INSERT NAME AND ADDRESS IN SPACE ABOVE LABELED 'VENDOR'

ADVERTISEMENT FOR BIDS

Sealed bids for **Phase 3 Road Paving Project For The Cedar Lakes Conference Center**, Ripley, West Virginia, will be received by the State of West Virginia, in accordance with the Request for Quotations issued by the Purchasing Division, until 1:30 pm, local time, on the date listed in the State's Request for Quotations. Bids will opened and publicly read aloud at that time.

The bidding documents consist of the Request for Quotations, plans, and specifications. Plans and specifications may be obtained by contacting: ZMM Architects & Engineers, 222 Lee Street West, Charleston, West Virginia 25302; 304-342-0159 (phone); 304-345-8144 (fax).

Up to 2 sets of bidding documents for this project may be obtained by qualified prime contractors from the office of ZMM, Inc., Architects and Engineers, 222 Lee Street West, Charleston, West Virginia 25302. A deposit of **\$75.00**, payable to ZMM, Inc., will be required for each set of documents. Deposits will be refunded if bidding documents are returned to the Architect in good condition within 20 days of bid date. Bidders will be responsible for cost of shipping and handling.

Request for Quotations may be obtained by contacting:

State Of West Virginia
Finance and Administration
Purchasing Division
2019 Washington Street, East
Charleston, West Virginia 25305
Phone: 304-558-2063

Bidding documents may be examined at Architect's office or at one of the following locations during regular business hours:

Kan. Valley Builder's Assoc. 1627 Bigley Avenue Charleston, WV 25302 304-342-7141	McGraw-Hill/F. W. Dodge 437 19 th Street Dunbar, WV 25064 304-766-6880/ FAX 304-766-6882	Contractors Association of West Virginia 2114 Kanawha Boulevard East Charleston, WV 25311 304-342-1166
--------------------------------------------------------------------------------------------	--------------------------------------------------------------------------------------------------------------	-----------------------------------------------------------------------------------------------------------------

Procedures, policies and relevant sections of law, as well as the terms and conditions, of the State of West Virginia and/or the Purchasing Division take precedence, over any similar language within the contract, required by the School Building Authority. Furthermore, in no instance will the requirements of the SBA lessen any requirement of the State of West Virginia and/or the Purchasing Division. The order of precedence over conflicting sections, shall be first, documents issued by the Purchasing Division, second, the specifications for the project as defined by the Architects, and third, any attachments or supplemental information included with the specifications.

A pre-bid conference will be held at Cedar Lakes Conference Center at the date and time listed in the State's Request for Quotations. Attendance at pre-bid conference is mandatory for all prime bidders.

STATE OF WEST VIRGINIA
Purchasing Division

PURCHASING AFFIDAVIT

VENDOR OWING A DEBT TO THE STATE:

West Virginia Code §5A-3-10a provides that: No contract or renewal of any contract may be awarded by the state or any of its political subdivisions to any vendor or prospective vendor when the vendor or prospective vendor or a related party to the vendor or prospective vendor is a debtor and the debt owed is an amount greater than one thousand dollars in the aggregate.

PUBLIC IMPROVEMENT CONTRACTS & DRUG-FREE WORKPLACE ACT:

If this is a solicitation for a public improvement construction contract, the vendor, by its signature below, affirms that it has a written plan for a drug-free workplace policy in compliance with Article 1D, Chapter 21 of the *West Virginia Code*. The vendor **must** make said affirmation with its bid submission. Further, public improvement construction contract may not be awarded to a vendor who does not have a written plan for a drug-free workplace policy in compliance with Article 1D, Chapter 21 of the *West Virginia Code* and who has not submitted that plan to the appropriate contracting authority in timely fashion. For a vendor who is a subcontractor, compliance with Section 5, Article 1D, Chapter 21 of the *West Virginia Code* may take place before their work on the public improvement is begun.

ANTITRUST:

In submitting a bid to any agency for the state of West Virginia, the bidder offers and agrees that if the bid is accepted the bidder will convey, sell, assign or transfer to the state of West Virginia all rights, title and interest in and to all causes of action it may now or hereafter acquire under the antitrust laws of the United States and the state of West Virginia for price fixing and/or unreasonable restraints of trade relating to the particular commodities or services purchased or acquired by the state of West Virginia. Such assignment shall be made and become effective at the time the purchasing agency tenders the initial payment to the bidder.

I certify that this bid is made without prior understanding, agreement, or connection with any corporation, firm, limited liability company, partnership or person or entity submitting a bid for the same materials, supplies, equipment or services and is in all respects fair and without collusion or fraud. I further certify that I am authorized to sign the certification on behalf of the bidder or this bid.

LICENSING:

Vendors must be licensed and in good standing in accordance with any and all state and local laws and requirements by any state or local agency of West Virginia, including, but not limited to, the West Virginia Secretary of State's Office, the West Virginia Tax Department, West Virginia Insurance Commission, or any other state agencies or political subdivision. Furthermore, the vendor must provide all necessary releases to obtain information to enable the Director or spending unit to verify that the vendor is licensed and in good standing with the above entities.

CONFIDENTIALITY:

The vendor agrees that he or she will not disclose to anyone, directly or indirectly, any such personally identifiable information or other confidential information gained from the agency, unless the individual who is the subject of the information consents to the disclosure in writing or the disclosure is made pursuant to the agency's policies, procedures and rules. Vendor further agrees to comply with the Confidentiality Policies and Information Security Accountability Requirements, set forth in <http://www.state.wv.us/admin/purchase/privacy/noticeConfidentiality.pdf>.

Under penalty of law for false swearing (*West Virginia Code* §61-5-3), it is hereby certified that the vendor affirms and acknowledges the information in this affidavit and is in compliance with the requirements as stated.

Vendor's Name: Kelly Paving, Inc.
Authorized Signature: Roger Thomas Date: 2/25/09



State of West Virginia
 Department of Administration
 Purchasing Division
 2019 Washington Street East
 Post Office Box 50130
 Charleston, WV 25305-0130

Request for Quotation

RFQ NUMBER
 EDD310043

PAGE
 1

ADDRESS CORRESPONDENCE TO ATTENTION OF:
 SHELLY MURRAY
 304-558-8801

VENDOR FOR

*709045414 304-424-7353
 KELLY PAVING INC
 PO BOX 366
 WILLIAMSTOWN WV 26187

SHIP TO

DEPARTMENT OF EDUCATION
 BUILDING 6
 1900 KANAWHA BOULEVARD, EAST
 CHARLESTON, WV
 25305-0330

DATE PRINTED	TERMS OF SALE	SHIP VIA	FOB	FREIGHT TERMS
01/28/2009				

BID OPENING DATE: 02/18/2009 BID OPENING TIME 01:30PM

LINE	QUANTITY	UOP	CAT NO	ITEM NUMBER	UNIT PRICE	AMOUNT
----- ADDENDUM NO. 1 -----						
<p style="text-align: right;">JAN 29 2009</p> <p>DUE TO INCLEMENT WEATHER, THE PREBID SCHEDULED FOR 01/27/2009 IS BEING POSTPONED TO 02/03/2009 AT 10:00 AM AT THE CEDAR LAKES CONFERENCE CENTER, RIPLEY, WV. AGAIN, ALL VENDORS INTERESTED IN SUBMITTING A BID FOR THIS PROJECT MUST ATTEND THIS MEETING. ANY VENDOR FAILING TO ATTEND WILL BE DISQUALIFIED. NO ONE PERSON MAY REPRESENT MORE THAN MORE VENDOR.</p> <p>THE TECHNICAL QUESTION SUBMISSION DEADLINE HAS ALSO BEEN EXTENDED FROM 01/29/2009 TO 02/05/2009. ALL TECHNICAL QUESTIONS MUST BE SUBMITTED IN WRITING TO SHELLY MURRAY IN THE PURCHASING DIVISION VIA MAIL, AT THE ADDRESS SHOWN AT THE TOP OF THIS ADDENDUM, VIA FAX AT 304-558-4115, OR VIA EMAIL AT SHELLY.L.MURRAY@WV.GOV. ALL TECHNICAL QUESTIONS RECEIVED, IF ANY, WILL BE ADDRESS BY ADDENDUM AFTER THE DEADLINE.</p> <p>THE BID OPENING HAS BEEN CHANGED:</p> <p>FROM: 02/11/2009 TO : 02/18/2009</p>						
----- END OF ADDENDUM NO. 1 -----						

SEE REVERSE SIDE FOR TERMS AND CONDITIONS			
SIGNATURE <i>Roger Armes</i>	TELEPHONE 304-424-7353	DATE 2/25/09	
TITLE Area Manager	FEIN 55-0583614	ADDRESS CHANGES TO BE NOTED ABOVE	

WHEN RESPONDING TO RFQ, INSERT NAME AND ADDRESS IN SPACE ABOVE LABELED 'VENDOR'



State of West Virginia
 Department of Administration
 Purchasing Division
 2019 Washington Street East
 Post Office Box 50130
 Charleston, WV 25305-0130

Request for Quotation

RFQ NUMBER
 EDD310043

PAGE
 1

ADDRESS CORRESPONDENCE TO ATTENTION OF
 SHELLY, MURRAY
 304-558-8801

VENDOR

*709045414 304-424-7353
 KELLY PAVING INC
 PO BOX 366
 WILLIAMSTOWN WV 26187

SHIP TO

DEPARTMENT OF EDUCATION
 BUILDING 6
 1900 KANAWHA BOULEVARD, EAST
 CHARLESTON, WV
 25305-0330

DATE PRINTED	TERMS OF SALE	SHIP VIA	F.O.B.	FREIGHT TERMS
02/06/2009				

BID OPENING DATE: 02/25/2009 BID OPENING TIME 01:30PM

LINE	QUANTITY	UOP	CAT NO	ITEM NUMBER	UNIT PRICE	AMOUNT
----- ADDENDUM NO. 2 ----- THIS ADDENDUM IS ISSUED TO EXTEND THE DEADLINE FOR QUESTION SUBMISSION: FROM: 02/05/2009 TO : 02/10/2009 THE BID OPENING DATE IS ALSO BEING EXTENDED: FROM: 02/18/2009 TO : 02/25/2009 ATTACHMENT: MANDATORY PRE-BID SIGN IN SHEET ----- END OF ADDENDUM NO. 2 -----						
0001	1	LS		968-42		
PAVING CONSTRUCTION						

SEE REVERSE SIDE FOR TERMS AND CONDITIONS

SIGNATURE <i>Roger Thomas</i>	TELEPHONE 304-424-7353	DATE 2/25/09
TITLE Area Manager	FEIN 55-0583614	ADDRESS CHANGES TO BE NOTED ABOVE.

WHEN RESPONDING TO RFQ, INSERT NAME AND ADDRESS IN SPACE ABOVE LABELED 'VENDOR'

EDD 310043
CEDAR LAKES - PHASE 3 - ROAD PAVING #0614
PRE-BID MEETING SIGN-IN SHEET
~~JANUARY 27, 2009~~ - 10:00 AM
FEB 03 2009

PLEASE PRINT

NAME: Tim Lowry
FIRM: Cedar Lakes Conf. Center
ADDRESS: _____
PHONE: _____ FAX: _____

NAME: Stacey Hobbs, John Miller
FIRM: Paving & Resurfacing Inc.
ADDRESS: _____
PHONE: 965-6162 FAX: 965-1557

NAME: Tod D. GREEN
FIRM: W.V. Paving Inc.
ADDRESS: 2950 Charles Avenue
Dunbar W.V. 25064
PHONE: 768-9733 FAX: 768-9351
T.Green@WV.Paving.com

NAME: Paul Collins
FIRM: Cedar Lakes Conference
ADDRESS: _____
PHONE: 372-3424 FAX: 372-7881
Cedar Lakes

NAME: Tom Waybright
FIRM: Cedar Lakes
ADDRESS: _____
PHONE: _____ FAX: _____

PLEASE PRINT

NAME: Thomas E. Williams
FIRM: KELLY Paving Inc
ADDRESS: P.O. Box 3106
Williamstown WV 26187
PHONE: 304 424 7353 FAX: 740 873 6505
twilliams@shadyand sandy.com

NAME: MILLARD A BRADSHAW
FIRM: BLACKTOP INDUSTRIES
ADDRESS: MEMPHIS TN
BLACKTOP 75 RAOI.COM
PHONE: 453 6196 FAX: 453 6430
453 6480

NAME: HANK WALKER
FIRM: ZMM WC
ADDRESS: 222 LEBEST WEST
CHARLESTON WV
PHONE: 304 342 0159 FAX: 304-345-8144
hank@zmm.com

NAME: Phillip Uy
FIRM: WV Dept of Education
ADDRESS: 1900 Kanawha Blvd E. Bldg 6 Rm 204
Charleston WV 25305
PHONE: 304 558 2686 FAX: 304 558 8867

NAME: _____
FIRM: _____
ADDRESS: _____
PHONE: _____ FAX: _____



State of West Virginia
 Department of Administration
 Purchasing Division
 2019 Washington Street East
 Post Office Box 50130
 Charleston, WV 25305-0130

Request for Quotation

RFQ NUMBER
EDD310043

PAGE
1

ADDRESS CORRESPONDENCE TO ATTENTION OF
SHELLY MURRAY
304-558-8801

VENDOR
 *709045414 304-424-7353
 KELLY PAVING INC
 PO BOX 366
 WILLIAMSTOWN WV 26187 FEB 25 2009

SHIP TO
 DEPARTMENT OF EDUCATION
 BUILDING 6
 1900 KANAWHA BOULEVARD, EAST
 CHARLESTON, WV
 25305-0330

DATE PRINTED	TERMS OF SALE	SHIP VIA	F.O.B.	FREIGHT TERMS
02/24/2009				

BID OPENING DATE: 03/11/2009 BID OPENING TIME 01:30PM

LINE	QUANTITY	UOP	CAT NO	ITEM NUMBER	UNIT PRICE	AMOUNT
----- ADDENDUM NO. 3 -----						
THIS ADDENDUM IS ISSUED TO ADDRESS THE QUESTIONS RAISE PRIOR TO THE QUESTION SUBMISSION DEADLINE OF 2/10/2009.						
THE BID OPENING DATE IS EXTENDED:						
FROM: 2/25/2009						
TO : 3/11/2009						
THE ATTACHED DRUG FREE WORKPLACE CONFORMANCE AFFIDAVIT MUST BE SUBMITTED WITH THE VENDOR'S BID.						
----- END OF ADDENDUM NO. 3 -----						
0001	1	LS		968-42		
PAVING CONSTRUCTION						

SIGNATURE <i>Roger Thomas</i>			SEE REVERSE SIDE FOR TERMS AND CONDITIONS		TELEPHONE 304-424-7353	DATE 3/11/09
TITLE Area Manager		FEIN 55-058-3614		ADDRESS CHANGES TO BE NOTED ABOVE		

WHEN RESPONDING TO RFQ, INSERT NAME AND ADDRESS IN SPACE ABOVE LABELED 'VENDOR'

EDD310043
ADDENDUM NO. 3

1. What are the options for waste material disposal?

The Cedar Lakes facility has need for fill on-site. Permissible fill/waste materials may be dumped on-site at the location designated by camp management. When feasible, it is preferred that the materials be separated by type (i.e. dirt and gravel separated from asphalt/concrete).

2. Was a "base coat" required in the project specifications as a barrier below the asphalt?

References to a "base coat", if any, should be removed from the project specifications. This process has been deemed to be an outdated technology. The specifications relating to a "prime coat" in the specifications are still applicable.

3. What were the project specifications relating to the use of herbicides?

Please see the attached architect's documents, specifically item #5.B.

4. What is the expected method of transition to the existing curb and gutter, particularly as shown in the architect's drawings as alternate 1?

Please see the attached architect's documents, specifically item #3.A.

5. What are the recommendations for the transition of pavement to the sidewalk along the northern side of the main loop in the area adjacent to the 2nd alternate, as shown in the architect's drawings? This problem is caused by different sections of sidewalk possessing inconsistent elevations.

Please see the attached architect's documents, specifically item #1.A and #1.B.

6. What is the expected length of the curb to be replaced (see keyed note #9 in alternate #3)?

Please see the attached architect's documents, specifically item #4.A.

7. In relation to the detail of 2/SD-7, where shall the transition to the curb height begin/end?

Please see the attached architect's documents, specifically item #5.A.

8. Is the weight limit known on the bridge?

The weight limit is unknown.

9. Upon the discovery of holes in the bridge decking, what will be the responsibility of the successful vendor?

Please see the attached architect's documents, specifically item #2.A.



ARCHITECTS & ENGINEERS

RECEIVED

2009 FEB 23 PM 3: 30

February 17, 2009

WV PURCHASING
DIVISION **ADDENDUM NO. 3**

RE: Phase Three Road Paving Project
Cedar Lakes Conference Center
Ripley, West Virginia
Architect's Project No. 0614

TO: Prospective Bidders

FROM: ZMM, Inc. Architects And Engineers

This Addendum forms a part of the Contract Documents and modifies the original Bidding Documents.

ATTACH THIS ADDENDUM TO THE FRONT COVER OF THE PROJECT MANUAL AND ACKNOWLEDGE RECEIPT OF THIS ADDENDUM IN THE SPACE PROVIDED ON THE BID FORM.

See Addendum No. 3 for the captioned project with State RFQ No. EDD310043 as issued by the State Of West Virginia Department Of Administration Purchasing Division as attached.

CHANGES TO DRAWINGS:

1. Drawing No. SD1 – Make the following Revisions:
 - A. Add Note to sidewalk in front of Lions Cottage to read: "Cold plane a six foot wide portion of existing road adjacent to existing sidewalk and curb to allow new overlayment to match elevation of existing pavement where it meets the curb. This will include full length of sidewalk (Approximately 650 Lineal Feet)."
 - B. Change Scale of Drawing from 1 inch = 60 feet 0 inches to 1 inch = 100 feet 0 inches.
2. Drawing No. SD2 – Make the following Revisions:
 - A. ADD to Keyed Note No. 8 the following: " Contractor will, to the best of his ability, keep debris from falling into Mill Creek through existing holes in bridge deck. Contractor will, prior to paving, install wood plugs in existing 2 inch holes in bridge deck.
3. Drawing No. SD3 – Make the following Revisions:
 - A. ADD to Keyed Note No. 3 the following: " Extend wearing layer of asphalt paving over top of existing concrete gutter to edge of curb."

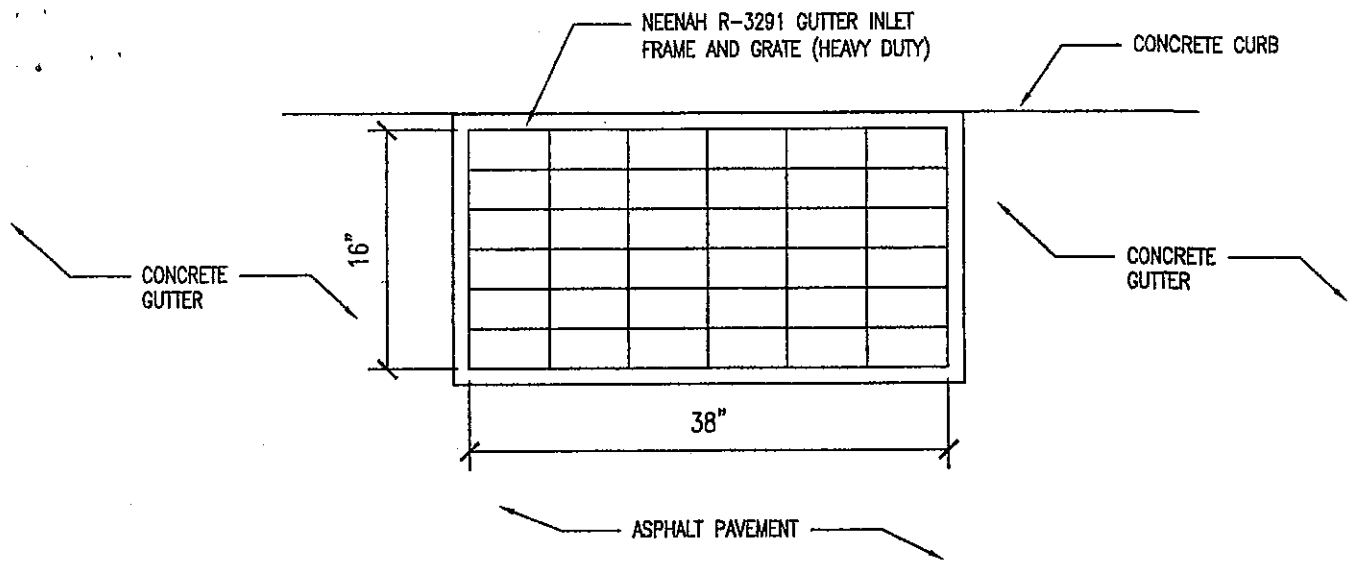

PLAN VIEW GUTTER INLET
SCALE: NTS

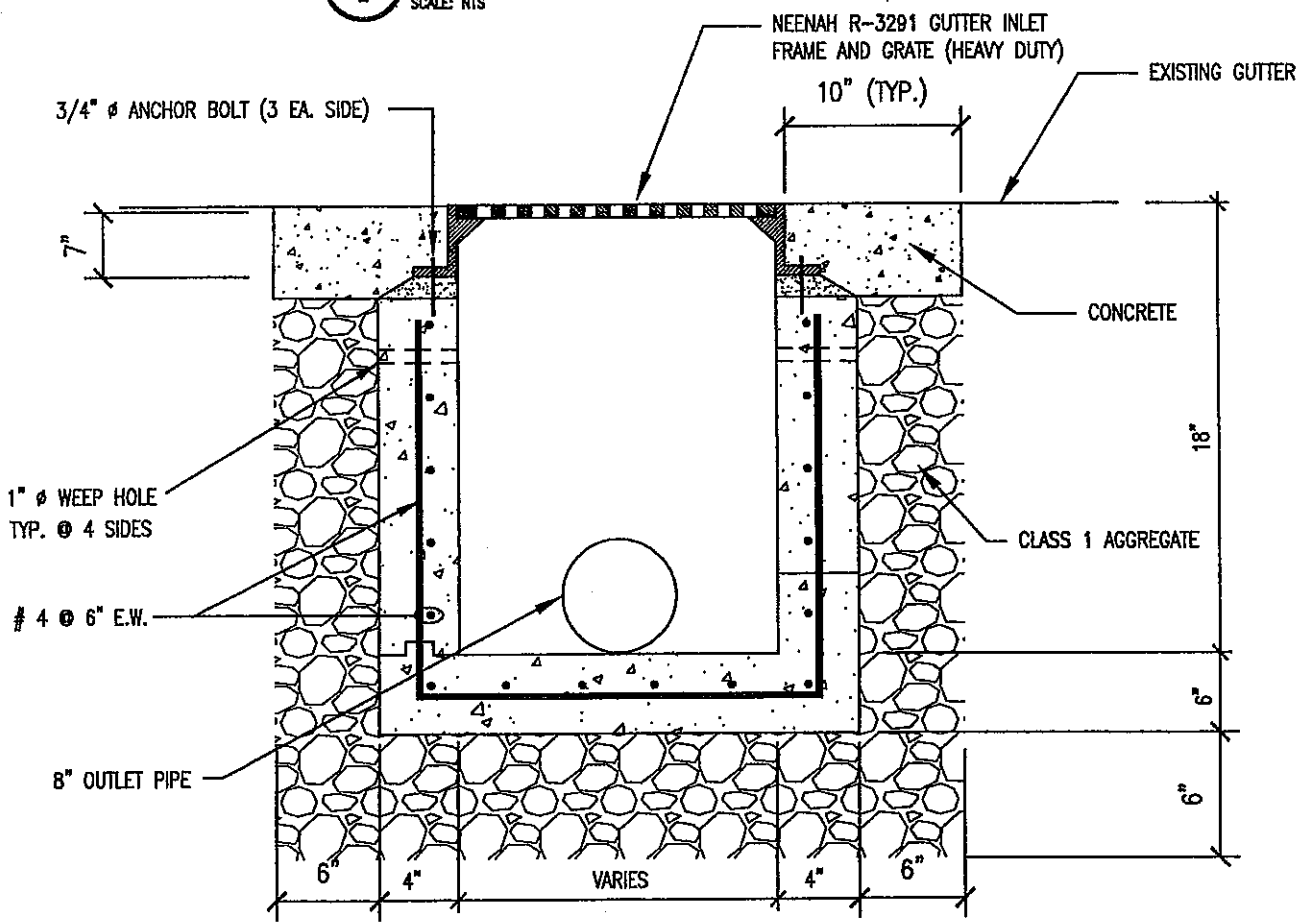

NOTE: OUTLET PIPE INVERT AND BOX INVERT SHALL MATCH.

INLET BOX DETAIL
SCALE: NTS

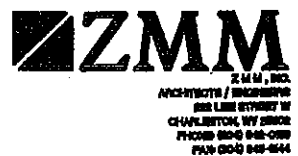

BID BOND

KNOW ALL MEN BY THESE PRESENTS, That we, the undersigned, Kelly Paving, Inc.
of P O Box 366, Williamstown, WV 26187, as Principal, and Ohio Farmers Insurance Company
of Westfield Center, Ohio, a corporation organized and existing under the laws of the State of Ohio
with its principal office in the City of Westfield Center, as Surety, are held and firmly bound unto the State
of West Virginia, as Obligee, in the penal sum of (5%) Five percent of amount bid for the payment of which,
well and truly to be made, we jointly and severally bind ourselves, our heirs, administrators, executors, successors and assigns.

The Condition of the above obligation is such that whereas the Principal has submitted to the Purchasing Section of the
Department of Administration a certain bid or proposal, attached hereto and made a part hereof, to enter into a contract in writing for

Cedar Lakes Paving Project
Jackson County, Ripley, WV

NOW THEREFORE,

- (a) If said bid shall be rejected, or
- (b) If said bid shall be accepted and the Principal shall enter into a contract in accordance with the bid or proposal attached hereto and shall furnish any other bonds and insurance required by the bid or proposal, and shall in all other respects perform the agreement created by the acceptance of said bid, then this obligation shall be null and void, otherwise this obligation shall remain in full force and effect. It is expressly understood and agreed that the liability of the Surety for any and all claims hereunder shall, in no event, exceed the penal amount of this obligation as herein stated.

The Surety, for the value received, hereby stipulates and agrees that the obligations of said Surety and its bond shall be in no way impaired or affected by any extension of the time within which the Obligee may accept such bid, and said Surety does hereby waive notice of any such extension.

IN WITNESS WHEREOF, Principal and Surety have hereunto set their hands and seals, and such of them as are corporations have caused their corporate seals to be affixed hereunto and these presents to be signed by their proper officers, this
18th day of February, 2009.

Principal Corporate Seal

Kelly Paving, Inc.
(Name of Principal)

By Wade Hamm
(Must be President or Vice President)
Vice President

VICE PRESIDENT
(Title)

Surety Corporate Seal

Ohio Farmers Insurance Company
(Name of Surety)

Kimberly L. Miles
Attorney-in-Fact
Licensed WV Resident Agent

IMPORTANT – Surety executing bonds must be licensed in West Virginia to transact surety insurance. Raised corporate seals must be affixed, a power of attorney must be attached.

General
Power
of Attorney

POWER NO. 4750172 01

**Westfield Insurance Co.
Westfield National Insurance Co.
Ohio Farmers Insurance Co.**
Westfield Center, Ohio

CERTIFIED COPY

Know All Men by These Presents, That WESTFIELD INSURANCE COMPANY, WESTFIELD NATIONAL INSURANCE COMPANY and OHIO FARMERS INSURANCE COMPANY, corporations, hereinafter referred to individually as a "Company" and collectively as "Companies," duly organized and existing under the laws of the State of Ohio, and having its principal office in Westfield Center, Medina County, Ohio, do by these presents make, constitute and appoint **ANDREW K. TEETER, KIMBERLY L. MILES, JANIS KAY PEACOCK, DOUGLAS P. TAYLOR, PAMELA D. OBRIEN, DONNA J. PRICE, TRAVIS A. HILL, JR., PAMELA V. LANHAM, JOINTLY OR SEVERALLY**

of **CHARLESTON** and State of **WV** its true and lawful Attorney(s)-in-Fact, with full power and authority hereby conferred in its name, place and stead, to execute, acknowledge and deliver any and all bonds, recognizances, undertakings, or other instruments or contracts of suretyship-

LIMITATION: THIS POWER OF ATTORNEY CANNOT BE USED TO EXECUTE NOTE GUARANTEE, MORTGAGE DEFICIENCY, MORTGAGE GUARANTEE, OR BANK DEPOSITORY BONDS.

and to bind any of the Companies thereby as fully and to the same extent as if such bonds were signed by the President, sealed with the corporate seal of the applicable Company and duly attested by its Secretary, hereby ratifying and confirming all that the said Attorney(s)-in-Fact may do in the premises. Said appointment is made under and by authority of the following resolution adopted by the Board of Directors of each of the WESTFIELD INSURANCE COMPANY, WESTFIELD NATIONAL INSURANCE COMPANY and OHIO FARMERS INSURANCE COMPANY:

"Be it Resolved, that the President, any Senior Executive, any Secretary or any Fidelity & Surety Operations Executive or other Executive shall be and is hereby vested with full power and authority to appoint any one or more suitable persons as Attorney(s)-in-Fact to represent and act for and on behalf of the Company subject to the following provisions:

The Attorney-in-Fact may be given full power and authority for and in the name of and on behalf of the Company, to execute, acknowledge and deliver, any and all bonds, recognizances, contracts, agreements of indemnity and other conditional or obligatory undertakings and any and all notices and documents canceling or terminating the Company's liability thereunder, and any such instruments so executed by any such Attorney-in-Fact shall be as binding upon the Company as if signed by the President and sealed and attested by the Corporate Secretary."

"Be it Further Resolved, that the signature of any such designated person and the seal of the Company heretofore or hereafter affixed to any power of attorney or any certificate relating thereto by facsimile, and any power of attorney or certificate bearing facsimile signatures or facsimile seal shall be valid and binding upon the Company with respect to any bond or undertaking to which it is attached." (Each adopted at a meeting held on February 8, 2000).

In Witness Whereof, WESTFIELD INSURANCE COMPANY, WESTFIELD NATIONAL INSURANCE COMPANY and OHIO FARMERS INSURANCE COMPANY have caused these presents to be signed by their Senior Executive and their corporate seals to be hereto affixed this 19th day of JUNE A.D., 2006 .

Corporate
Seals
Affixed



WESTFIELD INSURANCE COMPANY
WESTFIELD NATIONAL INSURANCE COMPANY
OHIO FARMERS INSURANCE COMPANY

Richard L. Kinnaird, Jr.

By: **Richard L. Kinnaird, Jr., Senior Executive**

State of Ohio
County of Medina ss.:

On this 19th day of JUNE A.D., 2006 , before me personally came **Richard L. Kinnaird, Jr.** to me known, who, being by me duly sworn, did depose and say, that he resides in **Medina, Ohio**; that he is **Senior Executive** of WESTFIELD INSURANCE COMPANY, WESTFIELD NATIONAL INSURANCE COMPANY and OHIO FARMERS INSURANCE COMPANY, the companies described in and which executed the above instrument; that he knows the seals of said Companies; that the seals affixed to said instrument are such corporate seals; that they were so affixed by order of the Boards of Directors of said Companies; and that he signed his name thereto by like order.

Notarial
Seal
Affixed



William J. Kahelin

William J. Kahelin, Attorney at Law, Notary Public
My Commission Does Not Expire (Sec. 147.03 Ohio Revised Code)

State of Ohio
County of Medina ss.:

I, **Frank A. Carrino**, Secretary of WESTFIELD INSURANCE COMPANY, WESTFIELD NATIONAL INSURANCE COMPANY and OHIO FARMERS INSURANCE COMPANY, do hereby certify that the above and foregoing is a true and correct copy of a Power of Attorney, executed by said Companies, which is still in full force and effect; and furthermore, the resolutions of the Boards of Directors, set out in the Power of Attorney are in full force and effect.

In Witness Whereof, I have hereunto set my hand and affixed the seals of said Companies at Westfield Center, Ohio, this 18th day of February A.D., 2009



Frank A. Carrino
Frank A. Carrino, Secretary



**State of West Virginia
DRUG FREE WORKPLACE CONFORMANCE AFFIDAVIT
West Virginia Code §21-1D-5**

STATE OF WEST VIRGINIA,

COUNTY OF Wood, **TO-WIT:**

I, Roger Thomas, after being first duly sworn, depose and state as follows:

1. I am an employee of Kelly Paving, Inc.; and,
(Company Name)
2. I do hereby attest that Kelly Paving, Inc.
(Company Name)

maintains a valid written drug free workplace policy and that such policy is in compliance with **West Virginia Code §21-1D-5**.

The above statements are sworn to under the penalty of perjury.

Kelly Paving, Inc.
(Company Name)

By: Roger Thomas
Title: Area Manager
Date: 3/11/09

Taken, subscribed and sworn to before me this 11th day of March, 2009.

By Commission expires May 14, 2016

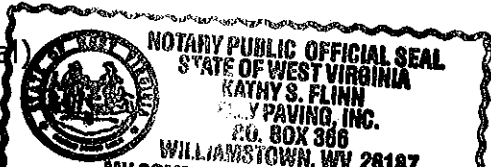
(Seal)  Kathy S. Flinn
(Notary Public)

THIS AFFIDAVIT MUST BE SUBMITTED WITH THE BID IN ORDER TO COMPLY WITH WV CODE PROVISIONS. FAILURE TO INCLUDE THE AFFIDAVIT WITH THE BID SHALL RESULT IN DISQUALIFICATION OF THE BID.

CONTRACTOR LICENSE

Authorized by the
West Virginia Contractor Licensing Board

Number: WV001884

Classification:
GENERAL ENGINEERING

KELLY PAVING INC
PO BOX 366
WILLIAMSTOWN, WV 26187-0366

Date Issued

Expiration Date

AUGUST 21, 2008

AUGUST 21, 2009



Authorized Company Signature

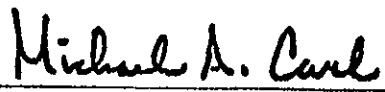

Chair, West Virginia Contractor
Licensing Board



**WEST VIRGINIA
CONTRACTOR
LICENSING
BOARD**

This license, or a copy thereof, must be posted in a conspicuous place at every construction site where work is being performed. This license number must appear in all advertisements, on all bid submissions and on all fully executed and binding contracts. This license cannot be assigned or transferred by licensee. Issued under provisions of West Virginia Code, Chapter 21, Article 11.

BID FORM

DATED: 2/25/09
(Bidder to insert date bid submitted)

SUBMITTED BY: (Name and Address) Kelly Paving, Inc. P.O. Box 366 Williamstown, WV
26187

WEST VIRGINIA CONTRACTOR LICENSE NUMBER: WV 001884

SUBMITTED TO: State of West Virginia
Finance and Administration
Purchasing Division

The undersigned, being familiar with local conditions affecting the cost of the work and the contract documents, including Instructions to Bidders, Bid Form, General Conditions, Drawings, and Specifications and any Addenda issued, hereby propose to perform everything required to be performed and to provide and furnish all the labor, materials, tools, expendable equipment and all services necessary to complete in a workmanlike manner all the work required for the:

ROAD PAVING PROJECT FOR THE CEDAR LAKES CONFERENCE CENTER

RIPLEY, WEST VIRGINIA

all in accordance with the drawings and specifications as prepared by ZMM, Inc., 222 Lee Street West, Charleston, West Virginia 25302, as follows:

BASE BID:

For the sum of: One hundred fifty two thousand four hundred sixty two dollars and
no cents (\$ 152,462.00).

ALTERNATES:

The stated Base Bid is subject to the following additions or deductions for Alternates which the Owner may select. ('Provide' means 'furnish and install.' Include in bids below all related coordination and modification requirements associated with the Work of each Alternate.)

Alternate Bid No. 1 - To construct the Assembly Loop as designated on Drawings as Alternate No. 1 and as specified.

ADD the sum of: Seventy seven thousand three hundred ninety dollars and no cents
 (\$ 77,390.00).

Alternate Bid No. 2 - To construct the Main Lodge Loop as designated on Drawings as Alternate No. 2 and as specified.

ADD the sum of: Fifty six thousand seven hundred ten dollars and no cents

(\$ 56,710.00).

Alternate Bid No. 3 - To construct the Mountaineer Lodge Loop as designated on Drawings as Alternate No. 3 and as specified.

ADD the sum of: Seventy five thousand five hundred seventy five dollars and

no cents (\$ 75,575.00).

Alternate Bid No. 4 - To construct the Dining Hall Loading as designated on Drawings as Alternate No. 4 and as specified.

ADD the sum of: Thirty nine thousand two hundred sixty five dollars and

no cents (\$ 39,265.00).

It is hereby certified that the undersigned is the only person(s) interested in this proposal as principal, and the proposal is made without collusion with any person, firm, or corporation. Bidder hereby agrees to execute the contract and furnish surety company bonds, in the forms incorporated in the contract documents, in the amount of one hundred (100%) percent of the contract price for performance, including maintenance, and for payment for labor and materials, respectively at the time required by the bidding documents, and to begin work within five (5) days following receipt of Notice to Proceed.

Bidder guarantees that, if awarded the contract, he will furnish and deliver all materials, tools, equipment, tests, transportation, secure all permits and licenses, and perform all labor, superintendence and all means of construction, pay all fees, except those specifically excluded in the Project Manual and do all incidental work to execute, construct, and finish the work in an expeditious, substantial, and workmanlike manner, in accordance with the contract documents to the complete satisfaction and acceptance of the Owner, for the prices stated.

It is understood that the Owner reserves the right to reject any/or all proposals, or part thereof or items therein, and to waive technicalities as required for the best interests of the Owner. It is further understood that competency and responsibility of bidders will receive consideration before the award of the contract.

The bidder hereby agrees that this proposal may not be revoked or withdrawn after the time set for the opening of bids but shall remain open for acceptance for a period of ninety days following such time.

The bidder hereby agrees to commence work under this contract on or before a date to be stipulated in the written Notice to Proceed by the Owner and to fully complete the scope of this prime contract in accordance with the Project Schedule and in sufficient time to permit FINAL COMPLETION of the entire project *within one hundred eighty (180) consecutive days of receipt of the Notice to Proceed.*

Liquidated damages will be assigned at the rate of \$500 per day for every calendar day thereafter beyond the 180 day limit stated in the Notice to Proceed.

THE CONTRACT AMOUNT STATED ABOVE INCLUDES ALL APPLICABLE SALES TAXES, EXCISE AND OTHER TAXES FOR MATERIALS AND APPLIANCES SUBJECT TO AND UPON WHICH TAXES ARE LEVIED.

The undersigned agrees that the contract documents are incorporated herein by reference and shall be construed to be part thereof, with the same affect as if such were repeated at length herein, or where physically attached hereto. The undersigned further certifies that: (1) this proposal is genuine and is not sham, collusive, or fraudulent; (2) this proposal is not made in the interest or in behalf of any person other than the undersigned; (3) the undersigned has not sought in any manner, by collusion or otherwise, to secure any advantage over any other bidders.

Enclosed herewith is a bid security prepared in accordance with the Instructions to Bidders in the amount of five percent (5%) of the amount of the bid (being not less than 5% of the total of the base bid). We agree that the above stated amount is the proper measure of liquidated damages which the owner will sustain by our failure to execute the contract and to furnish the performance bond in case this proposal is accepted.

If this proposal is accepted within 90 days after the date set for the opening of bids and the undersigned fails to execute the contract within 10 days after written notice of such acceptance or if the undersigned fails to furnish in full force and effect the required payment and performance bonds for the project, the bid security will be forfeited and the money payable thereon shall be paid into the funds of the owner as liquidated damages for such failure; otherwise, obligations of the bond will be null and void.

SIGNATURE OF BIDDER:

Firm: Kelly Paving, Inc.

By: Roger Thomas

Address: P.O. Box 366

Title: Area Manager

Address: Williamstown, WV

Phone: 304-424-7353

Address: 26187

Fax: 740-373-6505

END OF BID FORM