



State of West Virginia  
 Department of Administration  
 Purchasing Division  
 2019 Washington Street East  
 Post Office Box 50130  
 Charleston, WV 25305-0130

# Request for Quotation

RFQ NUMBER  
**DPS0927**

PAGE  
**1**

ADDRESS CORRESPONDENCE TO ATTENTION OF  
**JOHN ABBOTT  
 304-558-2544**

**\*709044322      304 746 0400**  
**R M HUFFMAN COMPANY**  
**PO BOX 8277**  
  
**SOUTH CHARLESTON WV 25303**

**WEST VIRGINIA STATE POLICE**  
  
**725 JEFFERSON ROAD**  
**SOUTH CHARLESTON, WV**  
**25309-1698**

|                                   |               |          |        |               |
|-----------------------------------|---------------|----------|--------|---------------|
| DATE PRINTED<br><b>01/28/2009</b> | TERMS OF SALE | SHIP VIA | F.O.B. | FREIGHT TERMS |
|-----------------------------------|---------------|----------|--------|---------------|

BID OPENING DATE: **02/19/2009**      BID OPENING TIME **01:30PM**

| LINE  | QUANTITY | UOP | CAT NO. | ITEM NUMBER | UNIT PRICE | AMOUNT |
|---|----------|-----|---------|-------------|------------|--------|
| 0001  | 1        | LS  |         | 493-99      |            |        |
| <b>EQUIPMENT: LABORATORY (MISCELLANEOUS)</b><br><br>PROVIDE ALL LABOR, MATERIALS, AND EQUIPMENT NECESSARY TO INSTALL LABORATORY CABINETS AND EQUIPMENT AT THE WEST VIRGINIA STATE POLICE HEADQUARTERS, S. CHARLESTON WV, PER THE SPECIFICATIONS.<br><br>MANDATORY ONSITE PRE-BID: 2/10/2009; 10:30 AM<br>WV STATE POLICE HEADQUARTERS<br>725 JEFFERSON ROAD<br>SOUTH CHARLESTON, WV 25309<br><br>NOTICE<br><br>A SIGNED BID MUST BE SUBMITTED TO:<br><br>DEPARTMENT OF ADMINISTRATION<br>PURCHASING DIVISION<br>BUILDING 15<br>2019 WASHINGTON STREET, EAST<br>CHARLESTON, WV 25305-0130<br><br>THE BID SHOULD CONTAIN THIS INFORMATION ON THE FACE OF THE ENVELOPE OR THE BID MAY NOT BE CONSIDERED:<br><br>SEALED BID |          |     |         |             |            |        |

**RECEIVED**  
**2009 FEB 19 PM 12:45**  
**WV PURCHASING DIVISION**

|   |                                  |                                   |  |
|---|----------------------------------|-----------------------------------|--|
| SEE REVERSE SIDE FOR TERMS AND CONDITIONS |                                  |                                   |  |
| SIGNATURE<br><i>Ronnie E. Huffman</i>     | TELEPHONE<br><b>304.746.0400</b> | DATE<br><b>FEB. 19, 2009</b>      |  |
| TITLE<br><b>PRESIDENT</b>                 | FEIN<br><b>55 056 3437</b>       | ADDRESS CHANGES TO BE NOTED ABOVE |  |

WHEN RESPONDING TO RFQ, INSERT NAME AND ADDRESS IN SPACE ABOVE LABELED 'VENDOR'

**GENERAL TERMS & CONDITIONS  
REQUEST FOR QUOTATION (RFQ) AND REQUEST FOR PROPOSAL (RFP)**

1. Awards will be made in the best interest of the State of West Virginia.
2. The State may accept or reject in part, or in whole, any bid.
3. All quotations are governed by the *West Virginia Code* and the *Legislative Rules* of the Purchasing Division.
4. Prior to any award, the apparent successful vendor must be properly registered with the Purchasing Division and have paid the required \$125 fee.
5. All services performed or goods delivered under State Purchase Order/Contracts are to be continued for the term of the Purchase Order/Contracts, contingent upon funds being appropriated by the Legislature or otherwise being made available. In the event funds are not appropriated or otherwise available for these services or goods, this Purchase Order/Contract becomes void and of no effect after June 30.
6. Payment may only be made after the delivery and acceptance of goods or services.
7. Interest may be paid for late payment in accordance with the *West Virginia Code*.
8. Vendor preference will be granted upon written request in accordance with the *West Virginia Code*.
9. The State of West Virginia is exempt from federal and state taxes and will not pay or reimburse such taxes.
10. The Director of Purchasing may cancel any Purchase Order/Contract upon 30 days written notice to the seller.
11. The laws of the State of West Virginia and the *Legislative Rules* of the Purchasing Division shall govern all rights and duties under the Contract, including without limitation the validity of this Purchase Order/Contract.
12. Any reference to automatic renewal is hereby deleted. The Contract may be renewed only upon mutual written agreement of the parties.
13. **BANKRUPTCY:** In the event the vendor/contractor files for bankruptcy protection, this Contract may be deemed null and void, and terminated without further order.
14. **HIPAA BUSINESS ASSOCIATE ADDENDUM:** The West Virginia State Government HIPAA Business Associate Addendum (BAA), approved by the Attorney General, and available online at the Purchasing Division's web site (<http://www.state.wv.us/admin/purchase/vrc/hipaa.htm>) is hereby made part of the agreement. Provided that, the Agency meets the definition of a Cover Entity (45 CFR §160.103) and will be disclosing Protected Health Information (45 CFR §160.103) to the vendor.
15. **WEST VIRGINIA ALCOHOL & DRUG-FREE WORKPLACE ACT:** If this Contract constitutes a public improvement construction contract as set forth in Article 1D, Chapter 21 of the West Virginia Code ("The West Virginia Alcohol and Drug-Free Workplace Act"), then the following language shall hereby become part of this Contract: "The contractor and its subcontractors shall implement and maintain a written drug-free workplace policy in compliance with the West Virginia Alcohol and Drug-Free Workplace Act, as set forth in Article 1D, Chapter 21 of the West Virginia Code. The contractor and its subcontractors shall provide a sworn statement in writing, under the penalties of perjury, that they maintain a valid drug-free work place policy in compliance with the West Virginia and Drug-Free Workplace Act. It is understood and agreed that this Contract shall be cancelled by the awarding authority if the Contractor: 1) Fails to implement its drug-free workplace policy; 2) Fails to provide information regarding implementation of the contractor's drug-free workplace policy at the request of the public authority; or 3) Provides to the public authority false information regarding the contractor's drug-free workplace policy."

---

**INSTRUCTIONS TO BIDDERS**

1. Use the quotation forms provided by the Purchasing Division.
2. **SPECIFICATIONS:** Items offered must be in compliance with the specifications. Any deviation from the specifications must be clearly indicated by the bidder. Alternates offered by the bidder as **EQUAL** to the specifications must be clearly defined. A bidder offering an alternate should attach complete specifications and literature to the bid. The Purchasing Division may waive minor deviations to specifications.
3. Complete all sections of the quotation form.
4. Unit prices shall prevail in case of discrepancy.
5. All quotations are considered F.O.B. destination unless alternate shipping terms are clearly identified in the quotation.
6. **BID SUBMISSION:** All quotations must be delivered by the bidder to the office listed below prior to the date and time of the bid opening. Failure of the bidder to deliver the quotations on time will result in bid disqualifications: Department of Administration, Purchasing Division, 2019 Washington Street East, P.O. Box 50130, Charleston, WV 25305-0130



State of West Virginia  
 Department of Administration  
 Purchasing Division  
 2019 Washington Street East  
 Post Office Box 50130  
 Charleston, WV 25305-0130

# Request for Quotation

RFQ NUMBER  
**DPS0927**

PAGE  
**2**

ADDRESS CORRESPONDENCE TO ATTENTION OF  
**JOHN ABBOTT**  
**304-558-2544**

VENDOR

**\*709044322      304 746 0400**  
**R M HUFFMAN COMPANY**  
**PO BOX 8277**  
  
**SOUTH CHARLESTON WV 25303**

SHIP TO

**WEST VIRGINIA STATE POLICE**  
  
**725 JEFFERSON ROAD**  
**SOUTH CHARLESTON, WV**  
**25309-1698**

|                                   |               |          |        |               |
|-----------------------------------|---------------|----------|--------|---------------|
| DATE PRINTED<br><b>01/28/2009</b> | TERMS OF SALE | SHIP VIA | F.O.B. | FREIGHT TERMS |
|-----------------------------------|---------------|----------|--------|---------------|

BID OPENING DATE: **02/19/2009**      BID OPENING TIME **01:30PM**

| LINE   | QUANTITY | UOP | CAT. NO. | ITEM NUMBER                     | UNIT PRICE | AMOUNT      |
|--|----------|-----|----------|---------------------------------|------------|-------------|
| BUYER:   |          |     |          | JOHN ABBOTT-----                |            |             |
| RFQ. NO.:  |          |     |          | DPS0927-----                    |            |             |
| BID OPENING DATE:  |          |     |          | 2/19/2009-----                  |            |             |
| BID OPENING TIME:  |          |     |          | 1:30 PM-----                    |            |             |
| PLEASE PROVIDE A FAX NUMBER IN CASE IT IS NECESSARY TO CONTACT YOU REGARDING YOUR BID: |          |     |          |                                 |            |             |
|  |          |     |          | ----- <i>304.746.5666</i> ----- |            |             |
| CONTACT PERSON (PLEASE PRINT CLEARLY):   |          |     |          |                                 |            |             |
|  |          |     |          | ----- <i>DAN HUFFMAN</i> -----  |            |             |
| ***** THIS IS THE END OF RFQ      DPS0927 ***** TOTAL:                                 |          |     |          |                                 |            | \$26,991.00 |

SEE REVERSE SIDE FOR TERMS AND CONDITIONS

|           |           |                                   |
|-----------|-----------|-----------------------------------|
| SIGNATURE | TELEPHONE | DATE                              |
| TITLE     | FEIN      | ADDRESS CHANGES TO BE NOTED ABOVE |

WHEN RESPONDING TO RFQ, INSERT NAME AND ADDRESS IN SPACE ABOVE LABELED 'VENDOR'

**West Virginia State Police – Processing Lab Renovation  
South Charleston, WV**

**Elevation 1/A2:**

| <u>Qty.</u> | <u>Product No.</u> | <u>Description</u>                    |
|-------------|--------------------|---------------------------------------|
| 10          | 04L02400           | Mldg black rubber per ft              |
| 2           | 800S7920           | 42x84x22 Tall case                    |
| 1           | 90L04000           | Corner st st                          |
| 1           | 950C070J           | Misc sink parts – portable demo table |
| 1           | BU001              | Modified mobile sink base unit        |
| 1           | CTOP               | 1”T black epoxy resin countertop      |

**Elevation 2/A3:**

| <u>Qty.</u> | <u>Product No.</u> | <u>Description</u>               |
|-------------|--------------------|----------------------------------|
| 16          | 04L02400           | Mldg black rubber per ft         |
| 1           | 140S2220           | 18x26x22 base cabt               |
| 1           | 164S2320           | 18x35x22 base cabt               |
| 1           | 422S6320           | 36x35x22 base corner cabt        |
| 1           | 501S2220           | 30x4x22 table frame              |
| 1           | 601M4330           | Filler, end 4x31x13              |
| 1           | 611S7220           | End filler 7-3/8x29              |
| 1           | 611S7320           | End filler 7-3/8x35              |
| 1           | 616S5220           | Knee space panel 30x20           |
| 1           | 709S2330           | 18x31x13 wall case               |
| 2           | 712S5330           | 30x31x13 wall case               |
| 1           | 724M2330           | 18x31x13 wall case corner        |
| 3           | 90L04000           | Corner st st                     |
| 1           | MS685763           | Filler vertical angle asm        |
| 1           | CTOP               | 1”T black epoxy resin countertop |

**Elevation 3/A4:**

| <u>Qty.</u> | <u>Product No.</u> | <u>Description</u>               |
|-------------|--------------------|----------------------------------|
| 30          | 04L02400           | Mldg black rubber per ft         |
| 1           | 136S4320           | 24x35x22 base cabt               |
| 1           | 146S6320           | 36x35x22 base cabt               |
| 1           | 164S4320           | 24x35x22 base cabt               |
| 2           | 501S4230           | 36x4x22 table frame              |
| 1           | 600S6320           | Front filler 6x35                |
| 1           | 601M4330           | Filler, end 4x31x13              |
| 2           | 616S6320           | Knee space panel 36x26           |
| 2           | 618S0360           | Filler, rear wall case           |
| 1           | 708S4330           | 24x31x13 wall case               |
| 1           | 712S5330           | 30x31x13 wall case               |
| 2           | 712S6330           | 36x31x13 wall case               |
| 4           | 90L04000           | Corner st st                     |
| 1           | CTOP               | 1”T black epoxy resin countertop |

**Elevation 4/A5:**

| <u>Qty.</u> | <u>Product No.</u> | <u>Description</u>               |
|-------------|--------------------|----------------------------------|
| 38          | 04L02400           | Mldg black rubber per ft         |
| 1           | 137S2320           | 18x35x22 base cabt               |
| 1           | 200S7320           | 42x35x22 base cabt               |
| 1           | 501S4230           | 36x4x22 table frame              |
| 1           | 600S2320           | Filler end 1x31                  |
| 1           | 616s6320           | Knee space panel 36x26           |
| 6           | 90L04000           | Corner st st                     |
| 1           | CTOP               | 1"T black epoxy resin countertop |

**Elevation 5/A6:**

| <u>Qty.</u> | <u>Product No.</u> | <u>Description</u>        |
|-------------|--------------------|---------------------------|
| 1           | 612S4320           | Center filler 14-3/4 x 35 |

**Elevation 6/A6:**

| <u>Qty.</u> | <u>Product No.</u> | <u>Description</u>     |
|-------------|--------------------|------------------------|
| 1           | 136S2320           | 18x35x22 base cabt     |
| 1           | 200S7320           | 42x35x22 base cabt     |
| 1           | 501S4230           | 36x4x22 table frame    |
| 1           | 600S2320           | Filler end 1x31        |
| 1           | 616S6320           | Knee space panel 36x26 |

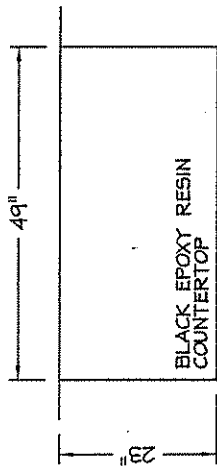

NOTE:  
MOBILE SINK UNIT TO  
INCLUDE 11"x15"x5'-D ST. ST.  
SINK, 5-GAL FRESH WATER  
SUPPLY, HAND WATER PUMP  
& 5-GAL WASTEWATER  
CONTAINER.

EXISTING  
EQUIPMENT

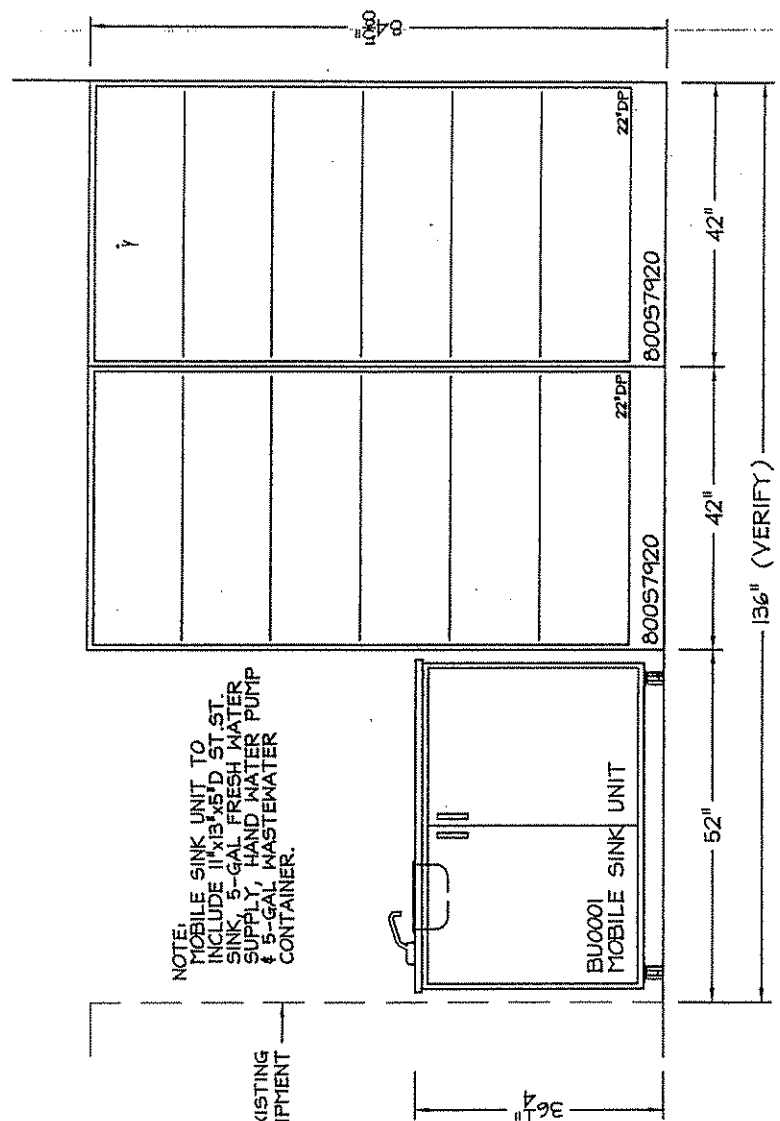

1  
A2

Elevation - Processing Lab

Scale: 1/2"=1'-0"

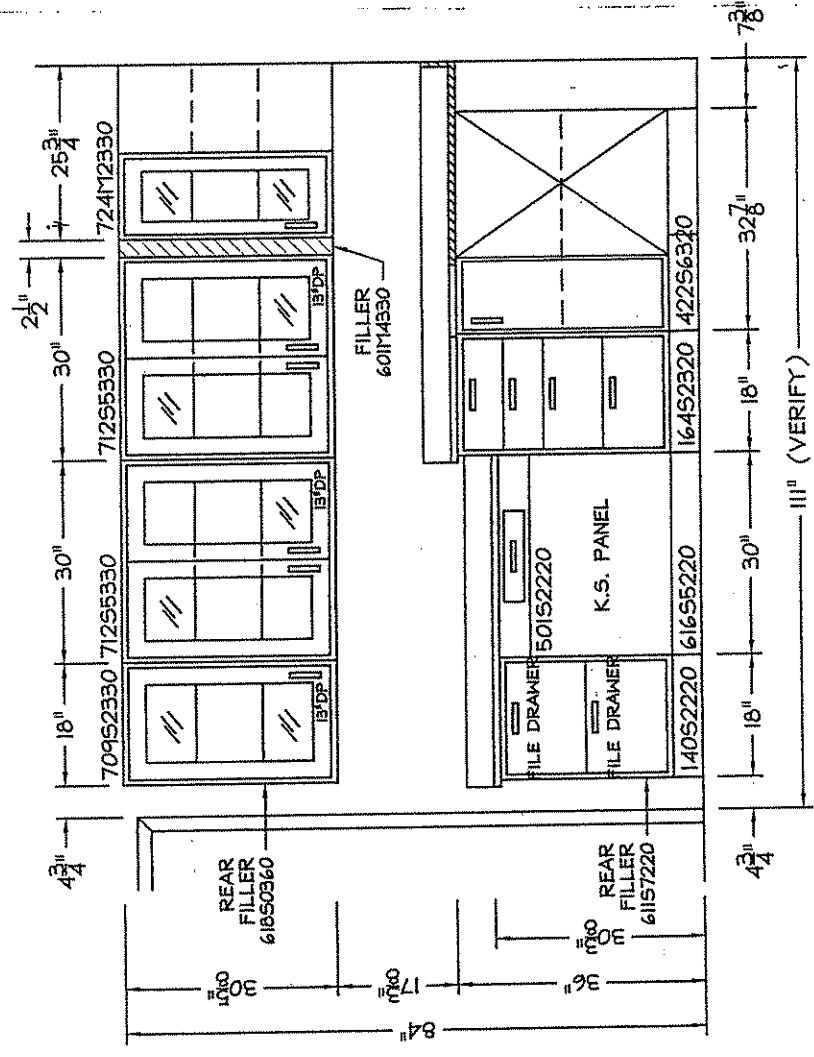
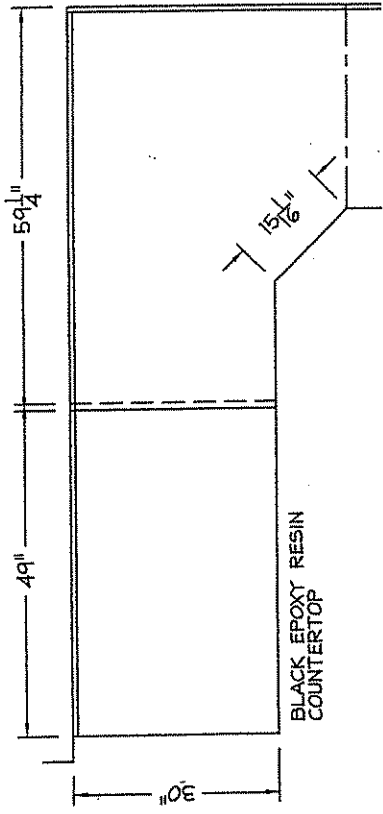

2 Elevation - Processing Lab  
 Scale: 1/2"=1'-0"

A3

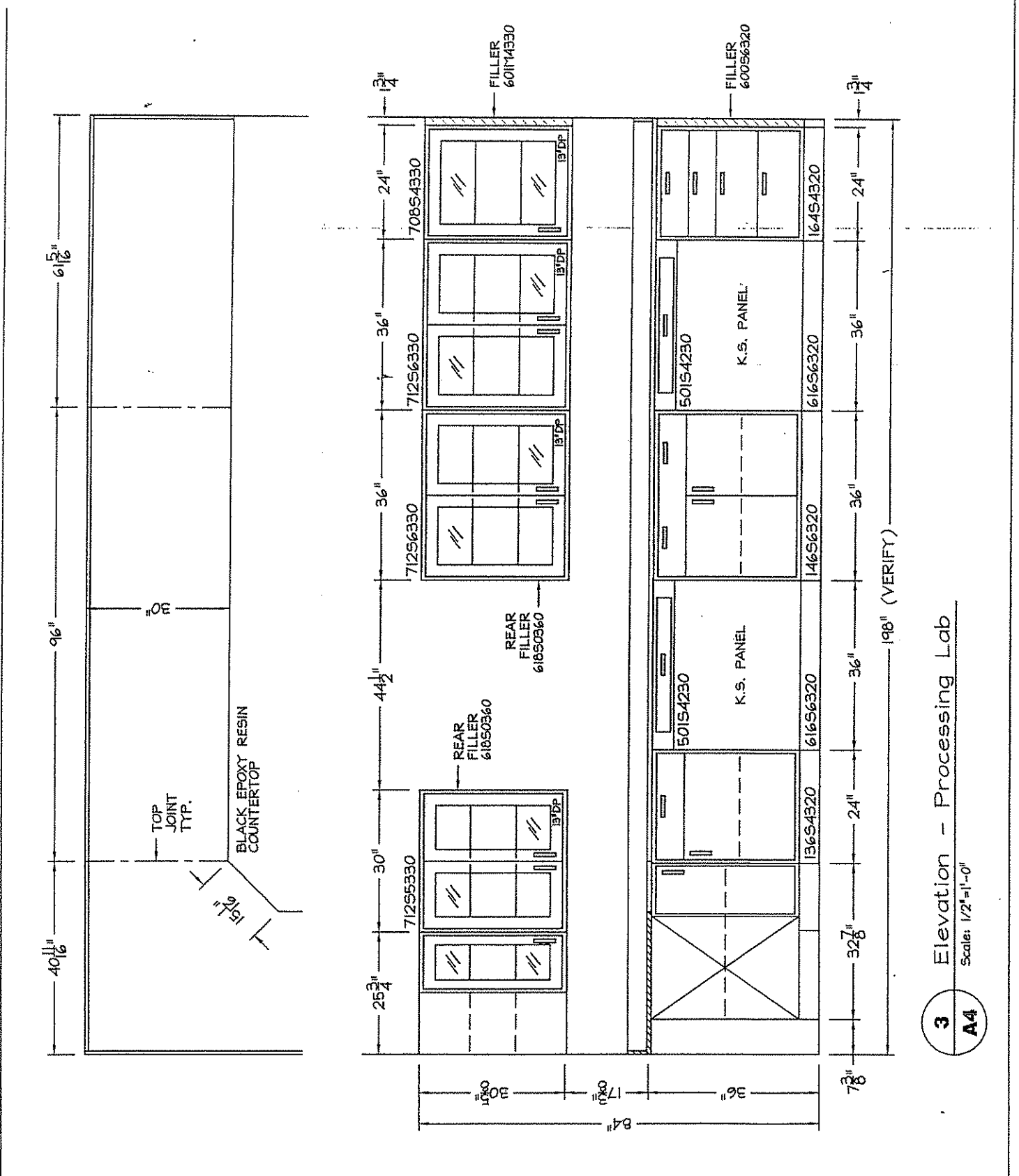

**3** Elevation - Processing Lab  
 Scale: 1/2"=1'-0"  
**A4**



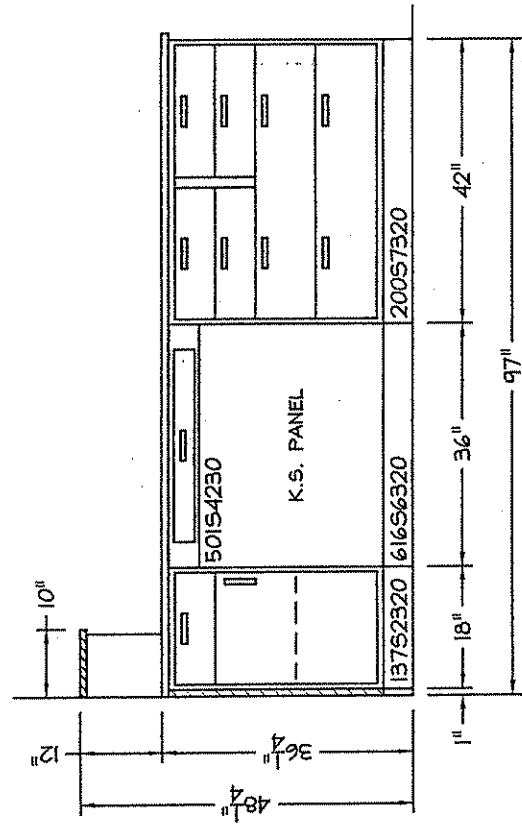
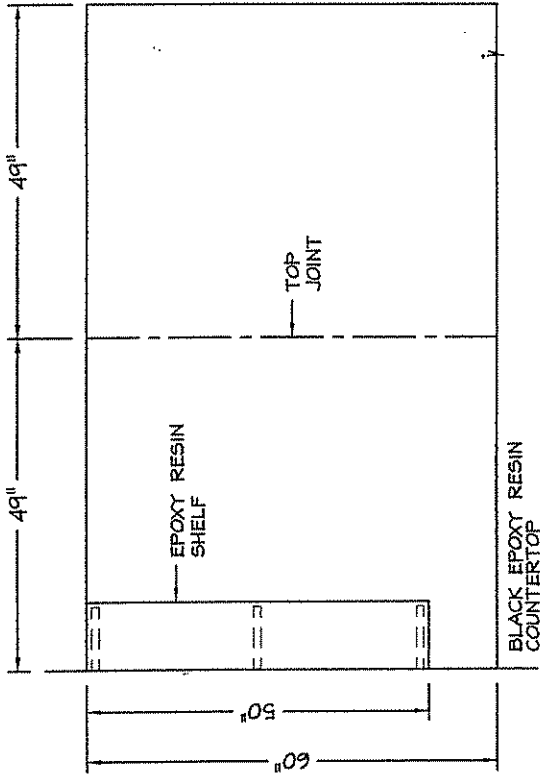

4 Elevation - Processing Lab  
 Scale: 1/2"=1'-0"  
 A5

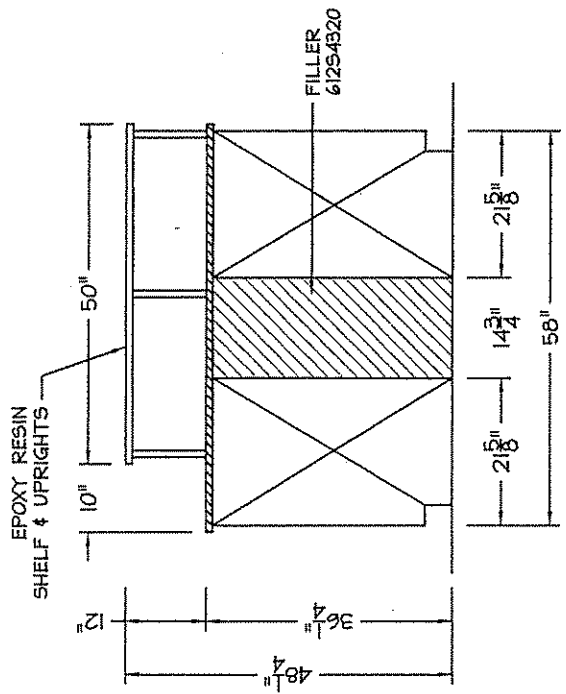

**5** Elevation - Processing Lab  
 Scale: 1/2"=1'-0"

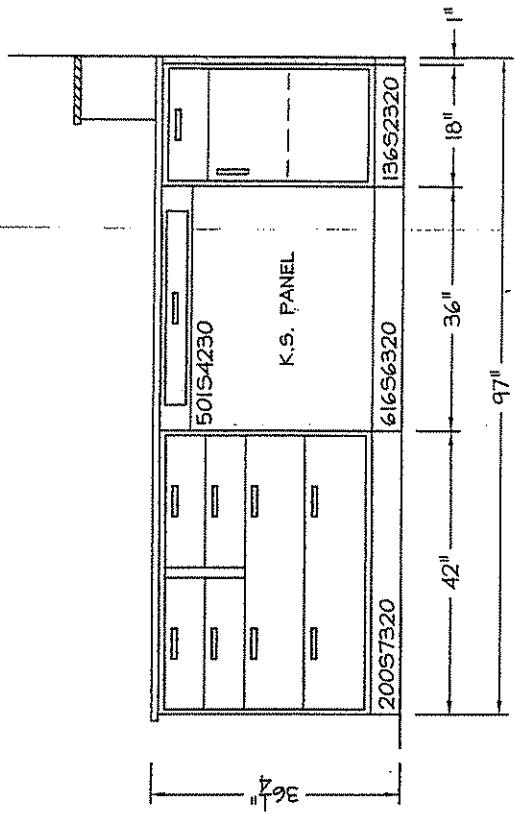

**6** Elevation - Processing Lab  
 Scale: 1/2"=1'-0"

INSET STEEL (MODULAR STEEL)  
LABORATORY CASEWORK  
V-4.3/05-01

## SECTION 12345.4 INSET STEEL LABORATORY CASEWORK

### PART 1 GENERAL

#### 1.00 SUMMARY

- A. Section Includes:
  - 1. Steel casework.
  - 2. Work surfaces.
  - 3. Accessory equipment.
  - 4. Project consists of product numbers per the attached sheets by elevation.
  
- B. Related Sections:
  - 1. **Installation of casework.**

#### 1.01 CASEWORK DESIGN REQUIREMENTS

- A. Flush construction: Surfaces of doors, drawers and panel faces shall align with cabinet fronts without overlap of case ends, top or bottom rails. Horizontal and vertical case shell members (panels, top rails and bottoms) shall meet in the same plane without overlap, cracks or crevices.
  
- B. Slimline styling: Front width of end panels 3/4" and front height of top and bottom members 1".
  
- C. Self-supporting units: Completely welded shell assembly without applied panels at ends, backs or bottoms, so that cases can be used interchangeably or as a single, stand-alone unit.
  
- D. Interior of case units: Easily cleanable, flush interior. Base cabinets, 30" and wider, with double swinging doors shall provide full access to complete interior without center vertical post.
  
- E. Drawers: Sized on a modular basis for interchange to meet varying storage needs, and designed to be easily removable in field without the use of special tools.

INSET STEEL (MODULAR STEEL)  
LABORATORY CASEWORK  
V-4.3/05-01

- F. Case openings: Rabbeted-like joints all four sides of case opening for hinged doors and two sides for sliding doors in order to provide dust resistant case.
- G. Framed glazed doors: Identical in construction, hardware and installation to solid panel doors. Design frame glazed doors to be removable for glass replacement.

## 1.02 CASEWORK PERFORMANCE REQUIREMENTS

- A. Structural performance requirements: Casework components shall withstand the following minimum loads without damage to the component or to the casework operation:
  - 1. Steel base unit load capacity: 500 lbs. per lineal foot.
  - 2. Suspended units: 300 lbs.
  - 3. Drawers in a cabinet: 150 lbs.
  - 4. Hanging wall cases: 300 lbs.
  - 5. Load capacity for shelves of base units, wall cases and tall cases: 100 lbs.
- B. Metal Finish Performance Requirements:
  - 1. Abrasion resistance: Maximum weight loss of 5.5 mg. per 100 cycle when tested on a Taber Abrasion Tester #E40101 with 1000 gm wheel pressure and Calibrase #CS10 wheel.
  - 2. Hardness: Surface hardness equivalent to 4H or 5H pencil.
  - 3. Humidity resistance: Withstand 1000 hour exposure in saturated humidity at 100 degrees F.
  - 4. Moisture resistance:
    - a. No visible effect to surface finish after boiling water trickled over test panel inclined at 45 degrees for five minutes.
    - b. No visible effect to surface finish following 100 hour continuous application of a water soaked cellulose sponge, maintained in a wet condition throughout the test period.
  - 5. Adhesion: Score finish surface of test panel with razor blade into 100 squares, 1/16" x 1/16", cutting completely through the finish but with minimum penetration of the substrate, and brush away particles with soft brush. Minimum 95 squares shall maintain their finish.
  - 6. Salt spray: Withstand minimum 200 hour salt spray test.

INSET STEEL (MODULAR STEEL)  
LABORATORY CASEWORK  
V-4.3/05-01

### 1.03 SUBMITTALS

- A. Shop Drawings: Provide 3/4" = 1'-0" scale elevations of individual and battery of casework units, cross sections, rough-in and anchor placements, tolerances and clearances. Indicate relation of units to surrounding walls, windows, doors and other building components. Provide 1/4" = 1'-0" rough-in plan drawings for coordination with trades. Rough-in shall show free area.
- B. Product Data: Submit manufacturer's data for each component and item of laboratory equipment specified. Include component dimensions, configurations, construction details, joint details, and attachments, utility and service requirements and locations.
- C. Product Samples Upon Request: Submit for approval:
  - 1. Top Sample.
  - 2. Finish Sample (3" X 5" Painted Steel).
- D. Finish Samples: Submit 3 x 5 inch samples of each color of finish for casework, work surfaces and for other prefinished equipment and accessories for selection by Owner.
- E. Test Reports: When requested by Owner, submit independent laboratory certified test reports verifying conformance to test performance specified.

### 1.04 QUALITY ASSURANCE

- A. Single source responsibility: Casework, work surfaces, and equipment and accessories shall be manufactured or furnished by a single laboratory furniture company.
- B. Manufacturer's qualifications: Modern plant with proper tools, dies, fixtures and skilled workmen to produce high quality laboratory casework and equipment, and shall meet the following minimum requirements:
  - 1. Ten years or more experience in manufacture of laboratory casework and equipment of type specified.
  - 2. Ten installations of equal or larger size and requirements.

INSET STEEL (MODULAR STEEL)  
LABORATORY CASEWORK  
V-4.3/05-01

- C. Installer's qualifications: Factory trained and/or certified by the manufacturer.
- D. Cabinet identification: Cabinets are identified on drawings by manufacturer's catalog numbers. Unless otherwise modified on drawings or in specifications, catalog description constitutes specific requirements for each type of cabinet.

### 1.05 DELIVERY, STORAGE AND HANDLING

- A. Schedule delivery of casework and equipment so that spaces are sufficiently complete that material can be installed immediately following delivery.
- B. Protect finished surfaces from soiling or damage during handling and installation. Keep covered with polyethylene film or other protective coating.
- C. Protect all work surfaces throughout construction period with 1/4" corrugated cardboard completely covering the top and securely taped to edges. Mark cardboard in large lettering "No Standing".

### 1.06 PROJECT CONDITIONS

- A. Do not deliver or install equipment until the following conditions have been met:
  - 1. Windows and doors are installed and the building is secure and weathertight.
  - 2. Ceiling, overhead ductwork and lighting are installed.
  - 3. All painting is completed and floor tile is installed.

## PART 2 PRODUCTS

### 2.01 MANUFACTURER

- A. Design, materials, construction and finish of casework specified is the minimum acceptable standard of quality for flush front steel laboratory

INSET STEEL (MODULAR STEEL)  
LABORATORY CASEWORK  
V-4.3/05-01

casework. The basis of this specification is Fisher Hamilton L.L.C., 1316 - 18th Street, Two Rivers, WI 54241 product.

## 2.02 CASEWORK MATERIALS

- A. Sheet steel: Mild, cold rolled and leveled unfinished steel.
- B. Minimum gauges:
  - 1. 20 gauge: Solid door interior panels, drawer fronts, scribing strips, filler panels, enclosures, drawer bodies, shelves, security panels and sloping tops.
  - 2. 18 gauge: Case tops, ends, bottoms, bases, backs, vertical posts, uprights, glazed door members, door exterior panels and access panels.
  - 3. 16 gauge: Top front rails, top rear gussets, intermediate horizontal rails, table legs and frames, leg rails and stretchers.
  - 4. 14 gauge: Drawer suspensions, door and case hinge reinforcements and front corner reinforcements.
  - 5. 11 gauge: Table leg corner brackets and gussets for leveling screws.
- C. Glass for glazed swinging and sliding doors and/or unframed doors: to be 6mm Clear Float Glass (framed)

## 2.03 CASEWORK FABRICATION

- A. Base Units and Cases:
  - 1. Base units and 25", 31" and 37" high wall cases: End panels and back reinforced with internal reinforcing front and rear posts.
  - 2. 49" and 84" high cases: Formed end panels with front and rear reinforcing post channels; back shall be formed steel panel, recessed 3/4" for mounting purposes.
  - 3. Posts: Front post fully closed with full height reinforcing upright. Shelf adjustment holes in front and rear posts shall be perfectly aligned for level setting, adjustable to 1/2" o.c.
  - 4. Secure intersection of case members with spot and arc welds. Provide gusset reinforcement at front corners.
  - 5. Base unit backs: Provide drawer units without backs and cupboard units with removable backs for access to services behind units.
  - 6. Base unit backs: Provide fixed backs at all drawer and cupboard

INSET STEEL (MODULAR STEEL)  
LABORATORY CASEWORK  
V-4.3/05-01

- units. No access to services behind.
7. Bottoms: Base units and 25", 31", 37" and 49" high wall cases shall have one piece bottom with front edge formed into front rail, rabbeted as required for swinging doors and drawers and flush design for sliding doors.
  8. Top rail for base units: Interlock with end panels, flush with front of unit.
  9. Horizontal intermediate rails: Recessed behind doors and drawer fronts.
  10. Base for base units: 4" high x 3" deep with formed steel base and 11 ga. die formed steel gussets at corners. Provide 3/8" diameter leveling screw with integral bottom flange of minimum 0.56 sq. in. area at each corner, accessible through openings in toe space.
  11. Tops of wall cases: One piece, with front edge formed into front rail.

B. Drawers:

1. Drawer fronts: 3/4" thick, double wall construction, prepainted prior to assembly and sound deadened.
2. Drawer bodies: Bottom and sides formed into one-piece center section with bottom and sides coved and formed top edges. Front and back panels spot welded to center section.
3. Drawer suspension: Heavy duty coved raceways for both case and drawer with nylon tired, ball bearing rollers; self-centering and self-closing when open to within 3" of the closed position.
4. Provide drawer with rubber bumpers. Friction centering devices are not acceptable.
5. Provide security panels for drawers with keyed different locks.
6. File drawers: Provide with 150# full extension slides for full access and operation.

C. Doors:

1. Solid panel doors: 3/4" thick, double wall, telescoping box steel construction with interior prepainted and sound deadened, top corners welded and ground smooth. Reinforce interior of front panel with welded steel hat channels. Hinges with screws to internal 14 gauge reinforcing in case and door. Hinges shall be removable; welding of hinges not acceptable. Doors shall close against rubber bumpers.
2. Frame glazed doors: Outer head to be one piece construction.



INSET STEEL (MODULAR STEEL)  
LABORATORY CASEWORK  
V-4.3/05-01

Inner head to consist of top, bottom and side framing members which are removable for installation or replacement of glass. Provide continuous vinyl glazing retainer to receive glass. In all other respects, framed glazed door construction and quality shall match solid panel doors.

3. Sliding doors - solid or framed glazed: Design for tilt-out removal after removal of bottom guide. Doors shall be hung with nylon tired sleeve bearing rollers in formed steel top hung track and shall close against rubber bumpers.
  4. Unframed sliding glass doors: Glass with edges ground set in extruded aluminum shoe with integral pulls, wheel assemblies and top and bottom extruded aluminum track. Provide rubber bumpers at fully opened and closed door position.
- D. Shelves:
1. Form front and back edges down and back 3/4". Form ends down 3/4".
  2. Reinforce shelves over 36" long with welded hat channel reinforcement the full width of shelf.
  3. Pull out shelves: Same suspension as specified for drawers.
- E. Base molding: 4" high, to be furnished and installed by flooring contractor.
- F. Corner base guards: 4" high #304 stainless steel corner guards.
- G. Hardware:
1. Drawer and hinged door pulls: Semi Recessed Polypropylene pulls.
  2. Sliding door pulls: Recessed stainless steel, styled and sized to harmonize with drawer pulls.
  3. Hinges: Institutional type, five knuckle projecting barrel hinges, minimum 2-1/2" long, type 302 or 304 stainless steel. Provide two hinges for doors up to 36" high; three hinges for doors over 36" high. Drill each leaf for three screw attachment to door and frame.
  4. Door catches: Adjustable type, spring actuated nylon roller catches.
  5. Elbow catches: Spring type of cadmium plated steel, with strike of suitable design.
  6. Locks: National Lock Remove-A-Core 5-disc tumbler, heavy duty

INSET STEEL (MODULAR STEEL)  
LABORATORY CASEWORK  
V-4.3/05-01

- cylinder type. Exposed lock noses shall be dull nickel (satin) plated and stamped with identifying numbers.
7. Keying: Locks [location shown on drawings] shall have capacity for 225 primary key changes. Master key one level with the potential of 40 different, non-interchangeable master key groups.
  8. Keys: Stamped brass available from manufacturer or local locksmith, and supplied in the following quantities unless otherwise specified:
    - 2 - for each keyed different lock.
    - 3 - for each group keyed alike locks.
    - 2 - for master keys for each system.
  9. Label holders: [Locations shown on drawings] Formed steel with satin chrome finish, 1" x 1-1/2", screw installed.
  10. Shelf clips: Die formed steel, zinc plated, designed to engage in shelf adjustment holes.

## 2.04 Casework Finish

### 2.04 METAL FINISH

- A. Metal finish:
  1. Preparation: Spray clean metal with a heated cleaner/phosphate solution, pretreat with iron phosphate spray, water rinse, and neutral final seal. Immediately dry in heated ovens, gradually cooled, prior to application of finish.
  2. Application: Electrostatically apply urethane powder coat of selected color and bake in controlled high temperature oven to assure a smooth, hard satin finish. Surfaces shall have a chemical resistant, ømgh grade laboratory furniture quality finish of the following thickness:
    - a. Exterior and interior exposed surfaces: 1.5 mil average and 1.2 mil min.
    - b. Backs of cabinets and other surfaces not exposed to view: 1.0 mil average.

INSET STEEL (MODULAR STEEL)  
LABORATORY CASEWORK  
V-4.3/05-01

B. Cabinet Surface Finish Tests:

The Scientific Equipment and Furniture Association (SEFA) is a voluntary international trade association representing members of the laboratory furniture, casework, fume hood and related equipment industry. The association was founded to promote this rapidly expanding industry and to improve the quality, safety and timely completion of laboratory facilities in accordance with customer requirements. **All steel laboratory furniture and equipment must be in full compliance with the SEFA 8-1998 Standard.**

### 8.0 Cabinet Surface Finish Tests

#### 8.1 Chemical Spot Test

##### 8.1.1 Purpose of Test

The purpose of the chemical spot test is to evaluate the resistance a finish has to chemical spills.

**Note: Many organic solvents are suspected carcinogens, toxic and/or flammable. Great care should be exercised to protect personnel and the environment from exposure to harmful levels of these materials.**

##### 8.1.2 Test Procedure

Obtain one sample panel measuring 14" x 24" (355.6mm x 609.6mm). The received sample to be tested for chemical resistance as described herein.

Place panel on a flat surface, clean with soap and water and blot dry. Condition the panel for 48-hours at 73+ 3F (23+ 2(C) and 50+ 5% relative humidity. Test the panel for chemical resistance using forty-nine different chemical reagents by one of the following methods:

**Method A** – Test volatile chemicals by placing a cotton ball saturated with reagent in the mouth of a one-ounce (29.574cc) bottle and inverting the bottle on the surface of the panel.

**Method B** – Test volatile chemicals by placing five drops of the reagent on the surface of the panel and covering with a 24mm watch glass, convex side down.

For both of the above methods, leave the reagents on the panel for a period of **one hour**. Wash off the panel with water, clean with detergent and naphtha, and rinse with deionized water. Dry with a towel and

INSET STEEL (MODULAR STEEL)  
LABORATORY CASEWORK  
V-4.3/05-01

evaluate after 24-hours at  $73\pm 3^{\circ}\text{F}$  ( $23\pm 2^{\circ}\text{C}$ ) and  $50\pm 5\%$  relative humidity using the following rating system:

- Level 0** – No detectable change.
- Level 1** – Slight change in color or gloss.
- Level 2** – Slight surface etching or severe staining.
- Level 3** – Pitting, cratering, swelling, or erosion of coating. Obvious and significant deterioration..

| Test No. | Chemical Reagent        | Test Method |
|----------|-------------------------|-------------|
| 1.       | Acetate, Amyl           | A           |
| 2.       | Acetate, Ethyl          | A           |
| 3.       | Acetic Acid, 98%        | B           |
| 4.       | Acetone                 | A           |
| 5.       | Acid Dichromate, 5%     | B           |
| 6.       | Alcohol, Butyl          | A           |
| 7.       | Alcohol, Ethyl          | A           |
| 8.       | Alcohol, Methyl         | A           |
| 9.       | Ammonium Hydroxide, 28% | B           |
| 10.      | Benzene                 | A           |
| 11.      | Carbon Tetrachloride    | A           |
| 12.      | Chloroform              | A           |
| 13.      | Chromic Acid, 60%       | B           |
| 14.      | Cresol                  | A           |
| 15.      | Dichlor Acetic Acid     | A           |
| 16.      | Dimethylformamide       | A           |
| 17.      | Dioxane                 | A           |
| 18.      | Ethyl Ether             | A           |
| 19.      | Formaldehyde, 37%       | A           |
| 20.      | Formic Acid, 90%        | B           |
| 21.      | Furfural                | A           |
| 22.      | Gasoline                | A           |
| 23.      | Hydrochloric Acid, 37%  | B           |
| 24.      | Hydrochloric Acid, 48%  | B           |
| 25.      | Hydrogen Peroxide, 3%   | B           |
| 26.      | Iodine, Tincture of     | B           |
| 27.      | Methyl Ethyl Ketone     | A           |
| 28.      | Methylene Chloride      | A           |
| 29.      | Mono Chlorobenzene      | A           |
| 30.      | Naphthalene             | A           |
| 31.      | Nitric Acid, 20%        | B           |

INSET STEEL (MODULAR STEEL)  
LABORATORY CASEWORK  
V-4.3/05-01

|     |   |   |
|-----|---|---|
| 32. | Nitric Acid, 30%  | B |
| 33. | Nitric Acid, 70%  | B |
| 34. | Phenol, 90%   | A |
| 35. | Phosphoric Acid, 85%                                    | B |
| 36. | Silver Nitrate, Saturated                               | B |
| 37. | Sodium Hydroxide, 10%                                   | B |
| 38. | Sodium Hydroxide, 20%                                   | B |
| 39. | Sodium Hydroxide, 40%                                   | B |
| 40. | Sodium Hydroxide, Flake                                 | B |
| 41. | Sodium Hydroxide, Saturated                             | B |
| 42. | Sulfuric Acid, 33%                                      | B |
| 43. | Sulfuric Acid, 77%                                      | B |
| 44. | Sulfuric Acid, 96%                                      | B |
| 45. | Sulfuric Acid, 77% and Nitric<br>Acid, 70%, equal parts | B |
| 46. | Toluene   | A |
| 47. | Trichloroethylene                                       | A |
| 48. | Xylene  | A |
| 49. | Zinc Chloride, Saturated                                | B |

### 8.1.3 Acceptance Level

Results will vary from manufacturer to manufacturer. **Laboratory grade finishes should result in no more than four Level 3 conditions.** Suitability for a given application is dependent upon the chemicals used in a given laboratory.

## 8.2 Hot Water Test

### 8.2.1 Purpose of Test

The purpose of this test is to insure the coating is resistant to hot water.

### 8.2.2 Test Procedure

Hot water, 190°F to 205°F (88°C to 96°C), shall be allowed to trickle (with a steady stream and at a rate of not less than 6 ounces (177.44cc) per minute on the surface, which shall be set at an angle of 45-degrees, for a period of five minutes.

**8.2.3 Acceptance Level**

After cooling and wiping dry, the finish shall show no visible effect from the hot water.

**8.3 Impact Test****8.3.1 Purpose of Test**

The purpose of this test is to evaluate the ductility of the coating.

**8.3.2 Test Procedure**

A one-pound ball approximately 2" (50.8mm) in diameter shall be dropped from a distance of 12" (304.8mm) onto a flat horizontal surface, coated to manufacturer's standard manufacturing method.

**8.3.3 Acceptance Level**

There shall be no visible evidence to the naked eye of cracks or checks in the finish due to impact.

**8.4 Paint Adhesion on Steel Test****8.4.1 Purpose of Test**

The paint adhesion test is used to determine the bond of the coating to steel. This does not apply to non-steel products.

**8.4.2 Test Procedure**

This test is based on ASTM D2197-86 "Standard Method of Test for Adhesion of Organic Coating". Two sets of eleven parallel lines 1/16" (1.587mm) apart shall be cut with a razor blade to intersect at right angles thus forming a grid of 100 squares. The cuts shall be made just deep enough to go through the coating, but not into the substrate. They shall then be brushed lightly with a soft brush for one minute. Examine under 100-foot candles of illumination.

**8.4.3 Acceptance Level**

Ninety or more of the squares shall show finish intact.

**8.5 Paint Hardness on Steel Test****8.5.1 Purpose of Test**

The paint hardness test is used to determine the resistance of the coatings to scratches.

INSET STEEL (MODULAR STEEL)  
LABORATORY CASEWORK  
V-4.3/05-01

**8.5.2 Test Procedure**

Pencils, regardless of their brand, are valued in this way: 8-H is the hardest, and next 11 order of diminishing hardness are 7-H, 6-H, 5-H, 4-H, 3-H, 2-H, H, F, HB, B (soft), 2-B, 3-B, 4-B, 5-B (which are softest).

The pencils shall be sharpened on emery paper to a wide sharp edge. Pencils of increasing hardness shall be pushed across the paint film in a chisel-like manner until one is found that will cut or scratch the film. The pencil used before that one, that is the hardest pencil that will not rupture the film, is then used to express or designate the hardness.

**8.5.3 Acceptance Level**

The paint shall have a hardness of 4-H minimum.

**2.05 EPOXY RESIN WORK SURFACES**

A. Material: Chemical and abrasion resistant, durable top of one inch thick cast material of epoxy resins and inert products, cast flat, with a uniform non-glare matte finish. Colors to be Black.

B. Backsplash curb: Same material as top but jointed and cemented to top. Provide where indicated on drawings. Tops abut wall surfaces and at reagent ledges. Include end curb where top abuts wall.

**PART 3 EXECUTION**

**3.01 INSTALLATION**

- A. Casework installation:
1. Set casework components plumb, square, and straight with no distortion and securely anchored to building structure. Shim as required using concealed shims.
  2. Bolt continuous cabinets together with joints flush, tight and uniform, and with alignment of adjacent units within 1/16" tolerance.
  3. Secure wall cabinets to solid supporting material, not to plaster, lath or gypsum board.
  4. Abut top edge surfaces in one true plane. Provide flush joints not to exceed 1/8" between top units.
- B. Work surface installation:
1. Where required due to field conditions, scribe to abutting surfaces.
  2. Only factory prepared field joints, located per approved shop

INSET STEEL (MODULAR STEEL)  
LABORATORY CASEWORK  
V-4.3/05-01

drawings, shall be permitted. Secure joints in field, where practicable, in the same manner as in factory, with dowels, splines, adhesive or fasteners recommended by manufacturer.

3. Secure work surfaces to casework and equipment components with material and procedures recommended by the manufacturer.
- C. Accessory installation: Install accessories and fittings in accordance with manufacturer's recommendations. Turn screws to seat flat; do not drive.

### 3.02 ADJUSTING

- A. Repair or remove and replace defective work, as directed by [Architect] [Owner] upon completion of installation.
- B. Adjust doors, drawers, hardware, fixtures and other moving or operating parts to function smoothly.

### 3.03 CLEANING

- A. Clean shop finished casework, touch up as required.
- B. Clean countertops with diluted dishwashing liquid and water leaving tops free of all grease and streaks. Use no wax or oils.

### 3.04 PROTECTION OF FINISHED WORK

- A. Provide all necessary protective measures to prevent exposure of casework and equipment from exposure to other construction activity.
- B. Advise contractor of procedures and precautions for protection of material, installed laboratory casework and fixtures from damage by work of other trades.



**BID BOND**

KNOW ALL MEN BY THESE PRESENTS, That we, the undersigned, R. M. Huffman Company  
of South Charleston, WV, as Principal, and Ohio Farmers Insurance Company  
of Westfield Center, OH, a corporation organized and existing under the laws of the State of OH  
with its principal office in the City of Westfield Center, as Surety, are held and firmly bound unto the State  
of West Virginia, as Obligee, in the penal sum of Five Percent of Amount Bid (\$ 5% ) for the payment of which,  
well and truly to be made, we jointly and severally bind ourselves, our heirs, administrators, executors, successors and assigns.

The Condition of the above obligation is such that whereas the Principal has submitted to the Purchasing Section of the  
Department of Administration a certain bid or proposal, attached hereto and made a part hereof, to enter into a contract in writing for  
WV State Police - Processing Lab - According to Plans & Specifications

NOW THEREFORE,

(a) If said bid shall be rejected, or  
(b) If said bid shall be accepted and the Principal shall enter into a contract in accordance with the bid or proposal attached  
hereto and shall furnish any other bonds and insurance required by the bid or proposal, and shall in all other respects perform the  
agreement created by the acceptance of said bid, then this obligation shall be null and void, otherwise this obligation shall remain in full  
force and effect. It is expressly understood and agreed that the liability of the Surety for any and all claims hereunder shall, in no event,  
exceed the penal amount of this obligation as herein stated.

The Surety, for the value received, hereby stipulates and agrees that the obligations of said Surety and its bond shall be in no  
way impaired or affected by any extension of the time within which the Obligee may accept such bid, and said Surety does hereby  
waive notice of any such extension.

IN WITNESS WHEREOF, Principal and Surety have hereunto set their hands and seals, and such of them as are corporations  
have caused their corporate seals to be affixed hereunto and these presents to be signed by their proper officers, this  
19th day of February, 2009.

Principal Corporate Seal

R. M. Huffman Company  
(Name of Prjncipal)  
By: *Ronni G. Huffman*  
(Must be President or  
Vice President)  
PRESIDENT  
(Title)

Surety Corporate Seal

Ohio Farmers Insurance Company  
(Name of Surety)  
By: *Patricia A. Moye*  
Patricia A. Moye, WV Resident Agent Attorney-in-Fact

IMPORTANT – Surety executing bonds must be licensed in West Virginia to transact surety insurance. Corporate seals must be affixed,  
and a power of attorney must be attached.

General Power of Attorney

Westfield Insurance Co. Westfield National Insurance Co. Ohio Farmers Insurance Co. Westfield Center, Ohio

CERTIFIED COPY

Know All Men by These Presents, That WESTFIELD INSURANCE COMPANY, WESTFIELD NATIONAL INSURANCE COMPANY and OHIO FARMERS INSURANCE COMPANY, corporations, hereinafter referred to individually as a "Company" and collectively as "Companies," duly organized and existing under the laws of the State of Ohio, and having its principal office in Westfield Center, Medina County, Ohio, do by these presents make, constitute and appoint LARRY D. KERR, GREGORY T. GORDON, STEPHEN B. STODDEN, PATRICIA A. MOYE, ALLAN L. MC VEY, KIMBERLY J. WILKINSON, JOINTLY OR SEVERALLY

of CHARLESTON and State of WV its true and lawful Attorney(s)-in-Fact, with full power and authority hereby conferred in its name, place and stead, to execute, acknowledge and deliver any and all bonds, recognizances, undertakings, or other instruments or contracts of suretyship-

LIMITATION: THIS POWER OF ATTORNEY CANNOT BE USED TO EXECUTE NOTE GUARANTEE, MORTGAGE DEFICIENCY, MORTGAGE GUARANTEE, OR BANK DEPOSITORY BONDS.

and to bind any of the Companies thereby as fully and to the same extent as if such bonds were signed by the President, sealed with the corporate seal of the applicable Company and duly attested by its Secretary, hereby ratifying and confirming all that the said Attorney(s)-in-Fact may do in the premises. Said appointment is made under and by authority of the following resolution adopted by the Board of Directors of each of the WESTFIELD INSURANCE COMPANY, WESTFIELD NATIONAL INSURANCE COMPANY and OHIO FARMERS INSURANCE COMPANY:

"Be It Resolved, that the President, any Senior Executive, any Secretary or any Fidelity & Surety Operations Executive or other Executive shall be and is hereby vested with full power and authority to appoint any one or more suitable persons as Attorney(s)-in-Fact to represent and act for and on behalf of the Company subject to the following provisions:

The Attorney-in-Fact. may be given full power and authority for and in the name of and on behalf of the Company, to execute, acknowledge and deliver, any and all bonds, recognizances, contracts, agreements of indemnity and other conditional or obligatory undertakings and any and all notices and documents canceling or terminating the Company's liability thereunder, and any such instruments so executed by any such Attorney-in-Fact shall be as binding upon the Company as if signed by the President and sealed and attested by the Corporate Secretary."

"Be it Further Resolved, that the signature of any such designated person and the seal of the Company heretofore or hereafter affixed to any power of attorney or any certificate relating thereto by facsimile, and any power of attorney or certificate bearing facsimile signatures or facsimile seal shall be valid and binding upon the Company with respect to any bond or undertaking to which it is attached." (Each adopted at a meeting held on February 8, 2000).

In Witness Whereof, WESTFIELD INSURANCE COMPANY, WESTFIELD NATIONAL INSURANCE COMPANY and OHIO FARMERS INSURANCE COMPANY have caused these presents to be signed by their Senior Executive and their corporate seals to be hereto affixed this 25th day of JUNE A.D., 2008 .

Corporate Seals Affixed



WESTFIELD INSURANCE COMPANY WESTFIELD NATIONAL INSURANCE COMPANY OHIO FARMERS INSURANCE COMPANY

Richard L. Kinnaird, Jr. (Signature)

By: Richard L. Kinnaird, Jr., Senior Executive

State of Ohio County of Medina ss.:

On this 25th day of JUNE A.D., 2008 , before me personally came Richard L. Kinnaird, Jr. to me known, who, being by me duly sworn, did depose and say, that he resides in Medina, Ohio; that he is Senior Executive of WESTFIELD INSURANCE COMPANY, WESTFIELD NATIONAL INSURANCE COMPANY and OHIO FARMERS INSURANCE COMPANY, the companies described in and which executed the above instrument; that he knows the seals of said Companies; that the seals affixed to said instrument are such corporate seals; that they were so affixed by order of the Boards of Directors of said Companies; and that he signed his name thereto by like order.

Notarial Seal Affixed



William J. Kahelin (Signature)

William J. Kahelin, Attorney at Law, Notary Public My Commission Does Not Expire (Sec. 147.03 Ohio Revised Code)

State of Ohio County of Medina ss.:

I, Frank A. Carrino, Secretary of WESTFIELD INSURANCE COMPANY, WESTFIELD NATIONAL INSURANCE COMPANY and OHIO FARMERS INSURANCE COMPANY, do hereby certify that the above and foregoing is a true and correct copy of a Power of Attorney, executed by said Companies, which is still in full force and effect; and furthermore, the resolutions of the Boards of Directors, set out in the Power of Attorney are in full force and effect.

In Witness Whereof, I have hereunto set my hand and affixed the seals of said Companies at Westfield Center, Ohio, this 19th day of February A.D., 2009



Frank A. Carrino (Signature) Frank A. Carrino, Secretary

# VENDOR PREFERENCE CERTIFICATE

Certification and application\* is hereby made for Preference in accordance with *West Virginia Code*, §5A-3-37. (Does not apply to construction contracts). *West Virginia Code*, §5A-3-37, provides an opportunity for qualifying vendors to request (at the time of bid) preference for their residency status. Such preference is an evaluation method only and will be applied only to the cost bid in accordance with the *West Virginia Code*. This certificate for application is to be used to request such preference. The Purchasing Division will make the determination of the Resident Vendor Preference, if applicable.

- 1. Application is made for 2.5% resident vendor preference for the reason checked:  
 Bidder is an individual resident vendor and has resided continuously in West Virginia for four (4) years immediately preceding the date of this certification; or,  
 Bidder is a partnership, association or corporation resident vendor and has maintained its headquarters or principal place of business continuously in West Virginia for four (4) years immediately preceding the date of this certification; or 80% of the ownership interest of Bidder is held by another individual, partnership, association or corporation resident vendor who has maintained its headquarters or principal place of business continuously in West Virginia for four (4) years immediately preceding the date of this certification; or,  
 Bidder is a nonresident vendor which has an affiliate or subsidiary which employs a minimum of one hundred state residents and which has maintained its headquarters or principal place of business within West Virginia continuously for the four (4) years immediately preceding the date of this certification; or,
- 2. Application is made for 2.5% resident vendor preference for the reason checked:  
 Bidder is a resident vendor who certifies that, during the life of the contract, on average at least 75% of the employees working on the project being bid are residents of West Virginia who have resided in the state continuously for the two years immediately preceding submission of this bid; or,
- 3. Application is made for 2.5% resident vendor preference for the reason checked:  
 Bidder is a nonresident vendor employing a minimum of one hundred state residents or is a nonresident vendor with an affiliate or subsidiary which maintains its headquarters or principal place of business within West Virginia employing a minimum of one hundred state residents who certifies that, during the life of the contract, on average at least 75% of the employees or Bidder's affiliate's or subsidiary's employees are residents of West Virginia who have resided in the state continuously for the two years immediately preceding submission of this bid; or,
- 4. Application is made for 5% resident vendor preference for the reason checked:  
 Bidder meets either the requirement of both subdivisions (1) and (2) or subdivision (1) and (3) as stated above; or,
- 5. Application is made for 3.5% resident vendor preference who is a veteran for the reason checked:  
 Bidder is an individual resident vendor who is a veteran of the United States armed forces, the reserves or the National Guard and has resided in West Virginia continuously for the four years immediately preceding the date on which the bid is submitted; or,
- 6. Application is made for 3.5% resident vendor preference who is a veteran for the reason checked:  
 Bidder is a resident vendor who is a veteran of the United States armed forces, the reserves or the National Guard, if, for purposes of producing or distributing the commodities or completing the project which is the subject of the vendor's bid and continuously over the entire term of the project, on average at least seventy-five percent of the vendor's employees are residents of West Virginia who have resided in the state continuously for the two immediately preceding years.

Bidder understands if the Secretary of Revenue determines that a Bidder receiving preference has failed to continue to meet the requirements for such preference, the Secretary may order the Director of Purchasing to: (a) reject the bid; or (b) assess a penalty against such Bidder in an amount not to exceed 5% of the bid amount and that such penalty will be paid to the contracting agency or deducted from any unpaid balance on the contract or purchase order.

By submission of this certificate, Bidder agrees to disclose any reasonably requested information to the Purchasing Division and authorizes the Department of Revenue to disclose to the Director of Purchasing appropriate information verifying that Bidder has paid the required business taxes, provided that such information does not contain the amounts of taxes paid nor any other information deemed by the Tax Commissioner to be confidential.

Under penalty of law for false swearing (*West Virginia Code*, §61-5-3), Bidder hereby certifies that this certificate is true and accurate in all respects; and that if a contract is issued to Bidder and if anything contained within this certificate changes during the term of the contract, Bidder will notify the Purchasing Division in writing immediately.

Bidder: THE R.M. HUFFMAN Co      Signed: Ronci E. Huffman  
 Date: FEB. 19, 2009      Title: PRESIDENT

\*Check any combination of preference consideration(s) indicated above, which you are entitled to receive.

STATE OF WEST VIRGINIA  
Purchasing Division**PURCHASING AFFIDAVIT****VENDOR OWING A DEBT TO THE STATE:**

**West Virginia Code §5A-3-10a** provides that: No contract or renewal of any contract may be awarded by the state or any of its political subdivisions to any vendor or prospective vendor when the vendor or prospective vendor or a related party to the vendor or prospective vendor is a debtor and the debt owed is an amount greater than one thousand dollars in the aggregate.

**PUBLIC IMPROVEMENT CONTRACTS & DRUG-FREE WORKPLACE ACT:**

If this is a solicitation for a public improvement construction contract, the vendor, by its signature below, affirms that it has a written plan for a drug-free workplace policy in compliance with Article 1D, Chapter 21 of the **West Virginia Code**. The vendor **must** make said affirmation with its bid submission. Further, public improvement construction contract may not be awarded to a vendor who does not have a written plan for a drug-free workplace policy in compliance with Article 1D, Chapter 21 of the **West Virginia Code** and who has not submitted that plan to the appropriate contracting authority in timely fashion. For a vendor who is a subcontractor, compliance with Section 5, Article 1D, Chapter 21 of the **West Virginia Code** may take place before their work on the public improvement is begun.

**ANTITRUST:**

In submitting a bid to any agency for the state of West Virginia, the bidder offers and agrees that if the bid is accepted the bidder will convey, sell, assign or transfer to the state of West Virginia all rights, title and interest in and to all causes of action it may now or hereafter acquire under the antitrust laws of the United States and the state of West Virginia for price fixing and/or unreasonable restraints of trade relating to the particular commodities or services purchased or acquired by the state of West Virginia. Such assignment shall be made and become effective at the time the purchasing agency tenders the initial payment to the bidder.

I certify that this bid is made without prior understanding, agreement, or connection with any corporation, firm, limited liability company, partnership or person or entity submitting a bid for the same materials, supplies, equipment or services and is in all respects fair and without collusion or fraud. I further certify that I am authorized to sign the certification on behalf of the bidder or this bid.

**LICENSING:**

Vendors must be licensed and in good standing in accordance with any and all state and local laws and requirements by any state or local agency of West Virginia, including, but not limited to, the West Virginia Secretary of State's Office, the West Virginia Tax Department, West Virginia Insurance Commission, or any other state agencies or political subdivision. Furthermore, the vendor must provide all necessary releases to obtain information to enable the Director or spending unit to verify that the vendor is licensed and in good standing with the above entities.

**CONFIDENTIALITY:**

The vendor agrees that he or she will not disclose to anyone, directly or indirectly, any such personally identifiable information or other confidential information gained from the agency, unless the individual who is the subject of the information consents to the disclosure in writing or the disclosure is made pursuant to the agency's policies, procedures and rules. Vendor further agrees to comply with the Confidentiality Policies and Information Security Accountability Requirements, set forth in <http://www.state.wv.us/admin/purchase/privacy/noticeConfidentiality.pdf>.

Under penalty of law for false swearing (**West Virginia Code §61-5-3**), it is hereby certified that the vendor affirms and acknowledges the information in this affidavit and is in compliance with the requirements as stated.

Vendor's Name: THE R.M. HUFFMAN Co.

Authorized Signature: *Rome E. Huffman* Date: FEB. 19, 2009