



State of West Virginia
 Department of Administration
 Purchasing Division
 2019 Washington Street East
 Post Office Box 50130
 Charleston, WV 25305-0130

Request for Quotation

RFQ NUMBER
DNR209115

PAGE
1

ADDRESS CORRESPONDENCE TO ATTENTION OF
**FRANK WHITTAKER
 304-558-2316**

VENDOR

*709054414 304 263 7857
 TAYLOR SPORTS & RECREATION
 PO BOX 1706
 MARTINSBURG WV 25402

SHIP TO

DIVISION OF NATURAL RESOURCES
 BERWIND LAKE WMA
 ATTN: PARK SUPERINTENDENT
 POST OFFICE BOX 38
 WARRIORMINE, WV
 24894

875-4663
2517

DATE PRINTED 04/09/2009	TERMS OF SALE 30 DAY NET	SHIP VIA MIRACLES	F.O.B. DESTINATION	FREIGHT TERMS PREPAID/30 DAY
BID OPENING DATE: 05/07/2009		BID OPENING TIME: 01:30PM		

LINE	QUANTITY	UOP	CAT. NO.	ITEM NUMBER	UNIT PRICE	AMOUNT
0001	1	LS		650-38		\$23,266
PLAYGROUND EQUIPMENT (NOT OTHERWISE CLASSIFIED)						
THE WEST VIRGINIA PURCHASING DIVISION, FOR THE AGENCY, THE WEST VIRGINIA DIVISION OF NATURAL RESOURCES IS SOLICITING BIDS FOR PLAYGROUND EQUIPMENT FOR BERWIND LAKE WMA.						
A MANDATORY PRE-BID CONFERENCE WILL BE HELD ON 04/22/09 AT 1:00 PM AT BERWIND LAKE WMA HEADQUARTERS. FAILURE TO ATTEND THE MANATORY PRE-BID MEETING WILL RESULT IN BID DISQUALIFICATION. AN INDIVIDUAL MAY NOT REPRESENT MORE THAN ONE FIRM AT THE MEETING.						
TECHNICAL QUESTIONS MAY BE SUBMITTED IN WRITING TO FRANK WHITTAKER IN THE PURCHASING DIVISION VIA FAX AT 304-558-4115 OR VIA EMAIL AT FRANK.M.WHITTAKER@WV.GOV DEADLINE FOR TECHNICAL QUESTIONS IS 04/27/09 AT 4:00 PM ALL TECHNICAL QUESTIONS WILL BE ANSWERED BY ADDENDUM AFTER THE DEADLINE.						
BANKRUPTCY: IN THE EVENT THE VENDOR/CONTRACTOR FILES FOR BANKRUPTCY PROTECTION, THIS CONTRACT MAY BE DEEMED NULL AND VOID, AND TERMINATED WITHOUT FURTHER ORDER.						
THE MODEL/BRAND/SPECIFICATIONS NAMED HEREIN ESTABLISH THE ACCEPTABLE LEVEL OF QUALITY ONLY AND ARE NOT INTENDED TO REFLECT A PREFERENCE OR FAVOR ANY PARTICULAR BRAND OR VENDOR. VENDORS WHO ARE BIDDING ALTERNATES SHOULD SO STATE AND INCLUDE PERTINENT LITERATURE AND SPECIFICATIONS. FAILURE TO PROVIDE						

RECEIVED

2009 MAY -6 PM 2:28

WV PURCHASING DIVISION

SEE REVERSE SIDE FOR TERMS AND CONDITIONS

SIGNATURE: **Thomas C. Hill** TELEPHONE: **304-744-6548** DATE: **5-5-09**

TITLE: **Regional Rep** FEIN: **55-0778347** ADDRESS CHANGES TO BE NOTED ABOVE

WHEN RESPONDING TO RFQ, INSERT NAME AND ADDRESS IN SPACE ABOVE LABELED 'VENDOR'



State of West Virginia
 Department of Administration
 Purchasing Division
 2019 Washington Street East
 Post Office Box 50130
 Charleston, WV 25305-0130

Request for Quotation

RFQ NUMBER:
DNR209115

PAGE:
2

ADDRESS CORRESPONDENCE TO ATTENTION OF:
**FRANK WHITTAKER
 304-558-2316**

VENDOR

*709054414 304 263 7857
 TAYLOR SPORTS & RECREATION
 PO BOX 1706

 MARTINSBURG WV 25402

SHIP TO

DIVISION OF NATURAL RESOURCES
 BERWIND LAKE WMA
 ATTN: PARK SUPERINTENDENT
 POST OFFICE BOX 38
 WARRIORMINE, WV
 24894 875-4663

DATE PRINTED	TERMS OF SALE	SHIP VIA	F.O.B.	FREIGHT TERMS
04/09/2009	<i>30 DAY NET</i>	<i>MIRACLE</i>	<i>Destination</i>	<i>Prepaid / 30 DAY</i>
BID OPENING DATE: 05/07/2009		BID OPENING TIME 01:30PM		

LINE	QUANTITY	UOP	CAT NO	ITEM NUMBER	UNIT PRICE	AMOUNT
<p>INFORMATION FOR ANY ALTERNATES MAY BE GROUNDS FOR REJECTION OF THE BID. THE STATE RESERVES THE RIGHT TO WAIVE MINOR IRREGULARITIES IN BIDS OR SPECIFICATIONS IN ACCORDANCE WITH SECTION 148-1-4(F) OF THE WEST VIRGINIA LEGISLATIVE RULES AND REGULATIONS.</p> <p style="text-align: center;">NOTICE</p> <p>A SIGNED BID MUST BE SUBMITTED TO:</p> <p style="text-align: center;">DEPARTMENT OF ADMINISTRATION PURCHASING DIVISION BUILDING 15 2019 WASHINGTON STREET, EAST CHARLESTON, WV 25305-0130</p> <p>THE BID SHOULD CONTAIN THIS INFORMATION ON THE FACE OF THE ENVELOPE OR THE BID MAY NOT BE CONSIDERED:</p> <p>SEALED BID</p> <p>BUYER: 44</p> <p>RFQ. NO.: DNR209115</p> <p>BID OPENING DATE: 05/07/09</p> <p>BID OPENING TIME: 1:30 PM</p> <p>PLEASE PROVIDE A FAX NUMBER IN CASE IT IS NECESSARY TO CONTACT YOU REGARDING YOUR BID: <i>304-744-6545</i></p>						

SEE REVERSE SIDE FOR TERMS AND CONDITIONS

SIGNATURE <i>Thomas C. Nels</i>	TELEPHONE <i>304-744-6548</i>	DATE <i>5-5-09</i>
TITLE <i>Regional Rep</i>	FEIN <i>55-0778347</i>	ADDRESS CHANGES TO BE NOTED ABOVE

WHEN RESPONDING TO RFQ, INSERT NAME AND ADDRESS IN SPACE ABOVE LABELED 'VENDOR'



State of West Virginia
 Department of Administration
 Purchasing Division
 2019 Washington Street East
 Post Office Box 50130
 Charleston, WV 25305-0130

Request for Quotation

RFQ NUMBER:
DNR209115

PAGE:
3

ADDRESS CORRESPONDENCE TO ATTENTION OF:
**FRANK WHITTAKER
 304-558-2316**

VENDOR

*709054414 304 263 7857
 TAYLOR SPORTS & RECREATION
 PO BOX 1706

 MARTINSBURG WV 25402

SHIP TO

DIVISION OF NATURAL RESOURCES
 BERWIND LAKE WMA
 ATTN: PARK SUPERINTENDENT
 POST OFFICE BOX 38
 WARRIORMINE, WV
 24894 875-4663

DATE PRINTED: 04/09/2009	TERMS OF SALE: 30 DAY NET	SHIP VIA: MIRACLE	F.O.B. DESTINATION	FREIGHT TERMS: Prepaid/30 Day net
BID OPENING DATE: 05/07/2009		BID OPENING TIME 01:30PM		

LINE	QUANTITY	UOP	CAT NO	ITEM NUMBER	UNIT PRICE	AMOUNT
----- CONTACT PERSON (PLEASE PRINT CLEARLY): <i>Thomas Nelson</i> -----						
***** THIS IS THE END OF RFQ DNR209115 ***** TOTAL: _____						

SEE REVERSE SIDE FOR TERMS AND CONDITIONS

SIGNATURE <i>Thomas P. Juhl</i>	TELEPHONE <i>304-744-6548</i>	DATE <i>5-5-09</i>
TITLE <i>Regional Rep</i>	FEIN <i>55-0778347</i>	ADDRESS CHANGES TO BE NOTED ABOVE

WHEN RESPONDING TO RFQ, INSERT NAME AND ADDRESS IN SPACE ABOVE LABELED 'VENDOR'

Berwind Lake Wildlife Management Area
PLAYGROUND EQUIPMENT SHEET

Please complete the below information concerning the brand(s) of equipment being bid in relation to this project. If bidding "or equal" brands, please attach manufacturer's literature documenting that it meets the mandatory requirements stated in the specifications. Vendors should note the areas of the provided manufacturer's literature that adheres to the mandatory requirements outlined in the Request For Quotation.

Item No.	Equipment	Manufacturer	Model
1	Pool Area Playground Miracle tarantula climber, Model #4561, or equal.	MIRACLE AS SPECED	#4561
2	Pool Area Playground Miracle, 630° typhoon slide, Model #65759, or equal.	MIRACLE	#65759
3	Pool Area Playground Miracle chipper squirrel "C" spring rider model #918, or equal.	MIRACLE	#918
4	Pool Area Playground Miracle pokey the snail "C" spring rider, Model #963, or equal.	MIRACLE	#963
5	Pool Area Playground Miracle 5" OD arch tire swing complete model #714852, or equal.	MIRACLE	#714852
6	Pool Area Playground Miracle 5" OD arch 2 bay swing frame 4 seats REQ MC, Model #7148524, or equal.	MIRACLE	#7148524
7	Pool Area Playground Miracle the whirl (merry-go-round), Model #303, or equal.	MIRACLE	#303
8	Entrance Area Playground Miracle, peak climber, Model #4582a2, or equal.	MIRACLE	#4582A2
9	Entrance Area Playground Miracle, 405° typhoon slide, Model #65749, or equal.	MIRACLE	#65749
10	Entrance Area Playground Miracle twin rider, Model #6081, or equal.	MIRACLE	#6081

Berwind Lake Wildlife Management Area
PLAYGROUND EQUIPMENT SHEET

Item No.	Equipment	Manufacturer	Model
11	Office Area Playground Miracle swing part slash proof seat with clevis, Model #284, or equal.	MIRACLE	#284
12	Office Area Playground Miracle swing part tot seat 360° with clevis model #299, or equal.	MIRACLE	#299
13	Office Area Playground Miracle OD arch one bay swing frame with two (2) s/p seats MC, Model #7148522s, or equal.	MIRACLE	#71485225
14	Engineered wood fiber or equal.	ZEAGER	ENGINEERED WOOD FIBER
15	Geo-textilefabric, 2,250 sq. ft. roll, or equal.	ZEAGER	FABRIC
16	Geo-textilefabric, 1,125 sq. ft. roll, or equal.	ZEAGER	FABRIC

Berwind Lake Wildlife Management Area Playground Equipment
PRICING SHEET

4

Item No.	Quantity	Description	Unit Price	Amount
1	1	Pool Area Playground Miracle tarantula climber, Model #4561, or equal.	\$1031	\$1031
2	1	Pool Area Playground Miracle, 630° typhoon slide, Model #65759, or equal.	\$3782	\$3782
3	1	Pool Area Playground Miracle chipper squirrel "C" spring rider model #918, or equal.	\$403	\$403
4	1	Pool Area Playground Miracle pokey the snail "C" spring rider, Model #963, or equal.	\$377	\$377
5	1	Pool Area Playground Miracle 5" OD arch tire swing complete model #714852, or equal.	\$1494	\$1494
6	1	Pool Area Playground Miracle 5" OD arch 2 bay swing frame 4 seats REQ MC, Model #7148524, or equal.	\$1945	\$1945
7	1	Pool Area Playground Miracle the whirl (merry-go-round), Model #303, or equal.	\$2186	\$2186
8	1	Entrance Area Playground Miracle, peak climber, Model #4582a2, or equal.	\$974	\$974
9	1	Entrance Area Playground Miracle, 405° typhoon slide, Model #65749, or equal.	\$2753	\$2753
10	1	Entrance Area Playground Miracle twin rider, Model #6081, or equal.	\$512	\$512
11	4	Office Area Playground Miracle swing part slash proof seat with clevis, Model #284, or equal.	\$29 EA	\$116
12	2	Office Area Playground Miracle swing part tot seat 360° with clevis model #299, or equal.	\$68 EA	\$136

Berwind Lake Wildlife Management Area Playground Equipment
PRICING SHEET

5

Item No.	Quantity	Description	Unit Price	Amount
13	1	Office Area Playground Miracle OD arch one bay swing frame with two (2) s/p seats MC, Model #7148522s, or equal.	\$1274	\$1274
14	5,800 sq. ft.	Engineered wood fiber or equal.	\$14.64	\$2800
15	2	Geo-textile fabric, 2,250 sq. ft. roll, or equal.	\$138 ea	\$276
16	1	Geo-textile fabric, 1,125 sq. ft. roll, or equal.	\$138	\$138
		TOTAL		\$20,197



Product Specifications

Dec. 19, 2002 Rev. A

MIRACLE
RECREATION EQUIPMENT COMPANY

Tarantula Climber

456-1

Tarantula Climber

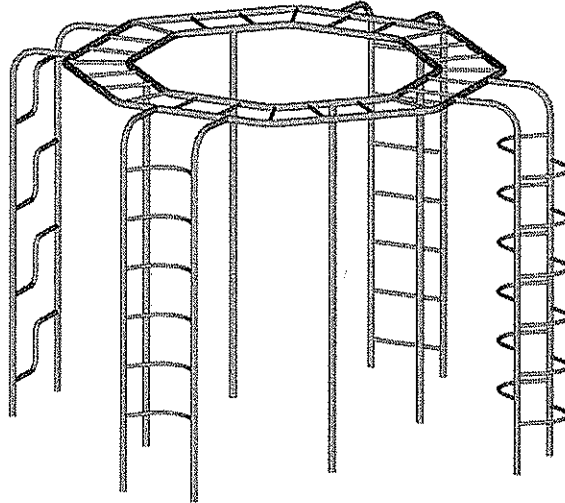

Tarantula Climber

456-1



Product Specifications

Rev. D

MIRACLE
RECREATION EQUIPMENT COMPANY

Freestanding Typhoon Slides - Platform Heights of 6'-3", 9'-4" & 12'

Freestanding Typhoon Slides

65-748 and 65-749

Freestanding Typhoon Slide, 360°,
6'-3" Platform

Freestanding Typhoon Slide, 405°,
6'-3" Platform

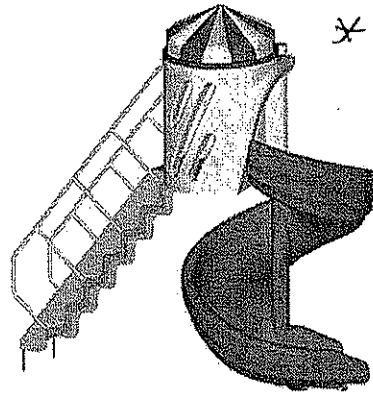
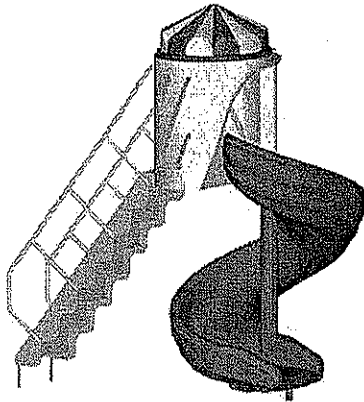

65-759 and 65-769

Freestanding Typhoon Slide, 630°,
9'-4" Platform

Freestanding Typhoon Slide, 855°,
12' Platform

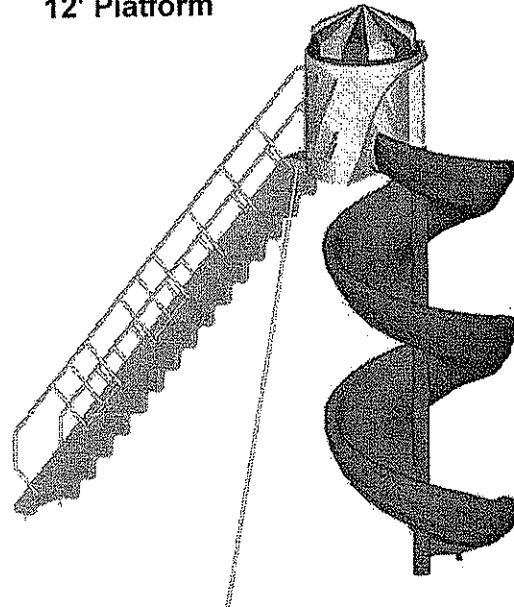
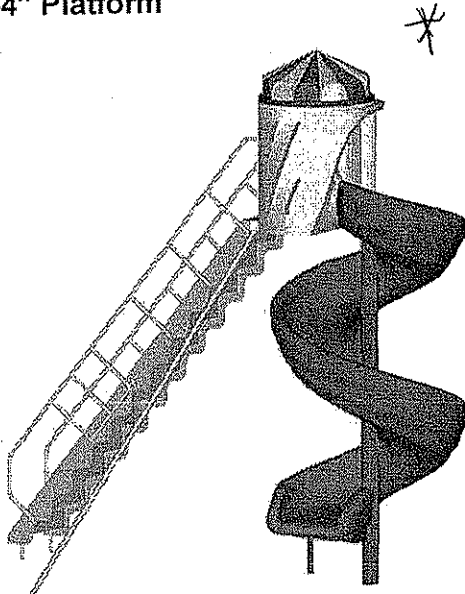



Product Specifications

MIRACLE
RECREATION EQUIPMENT COMPANY

"C" Spring Riders - Rodeo Rocky, Cleo Lion, Chipper Squirrel, Sammy Seal, Moto-Cross, Frog, Schnozz Wump, Elephant, Jet Interceptor & ATV

901

"Rodeo Rocky" "C" Spring Rider

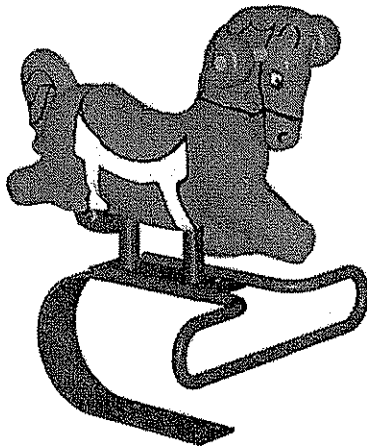

917

"Cleo Lion" "C" Spring Rider

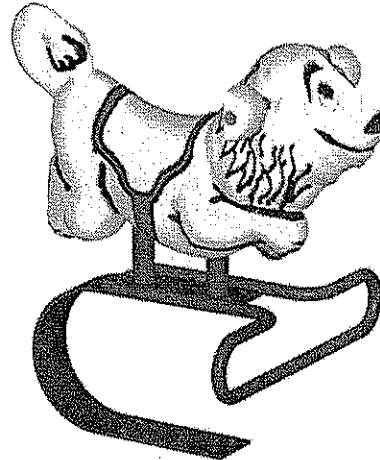

918

"Chipper Squirrel" "C" Spring Rider

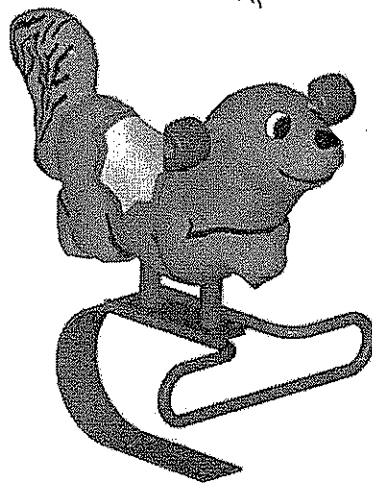

919

"Sammy Seal" "C" Spring Rider



"C" Spring Riders

"C" Spring Riders

920

Moto-Cross "C" Spring Rider

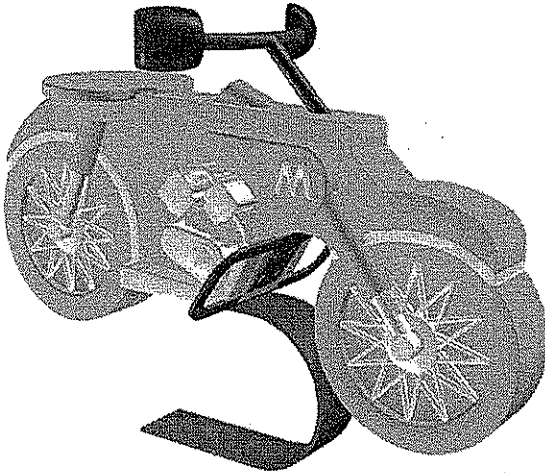

932

Frog "C" Spring Rider

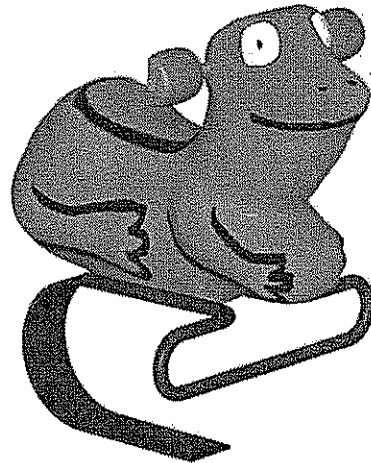

933

"Schnozz Wump" "C" Spring Rider

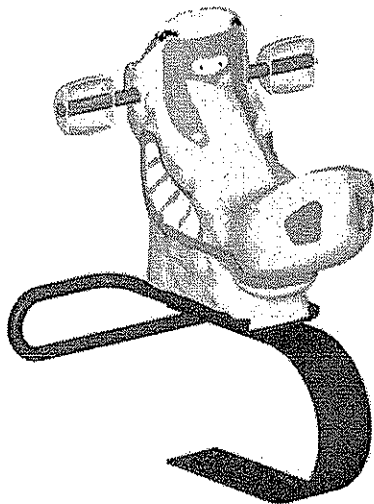

938

Elephant "C" Spring Rider

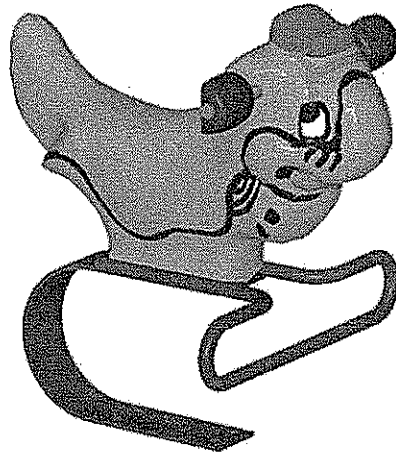



MIRACLE "C" Spring Riders

940

Jet Interceptor "C" Spring Rider

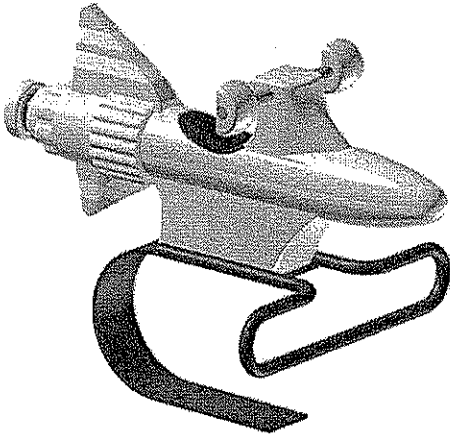

953

ATV "C" Spring Rider

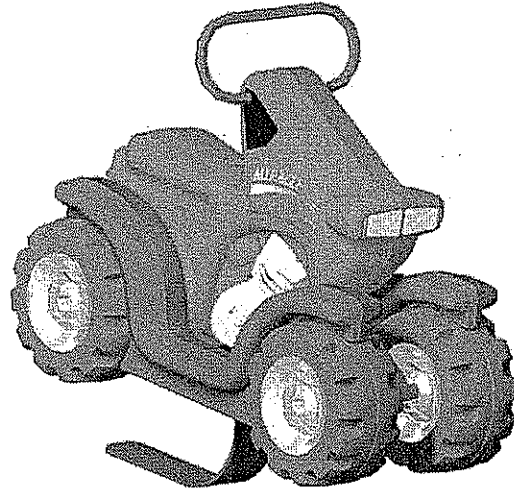

"C" Spring Riders



Product Specifications

January 20, 2009

Rev. C

MIRACLE
RECREATION EQUIPMENT COMPANY

"C" Spring Riders Hoppy & Pokey

962

Hoppy "C" Spring Rider

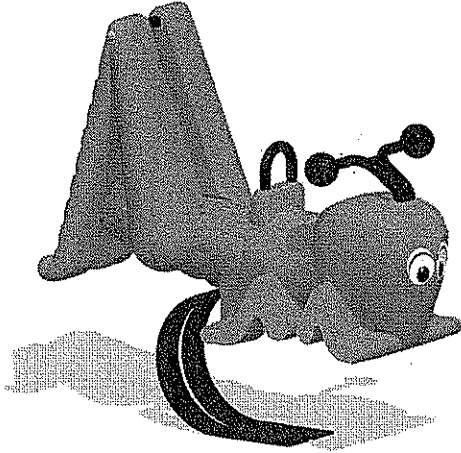

963

Pokey "C" Spring Rider

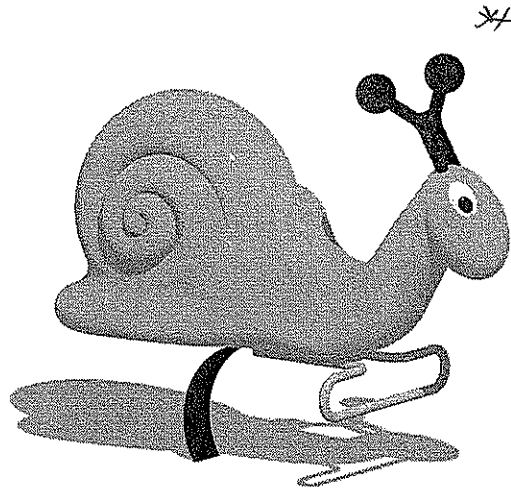

"C" Spring Riders



Product Specifications

Kids' Choice®

Arch Tire Swing and Arch Tire Swing Extension

714-852



Arch Tire Swing

(2) End Arches, (1) Header & (1) Tire Swing Assembly form (1) Complete Bay

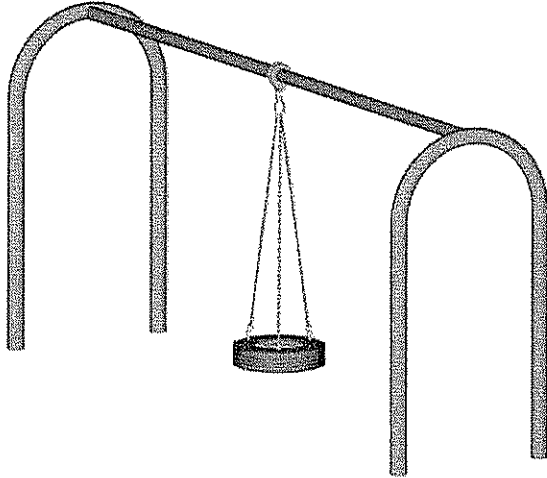

714-852-X

Arch Tire Swing Extension

(1) Extension Arch, (1) Header & (1) Tire Swing Assembly form (1) Additional Bay

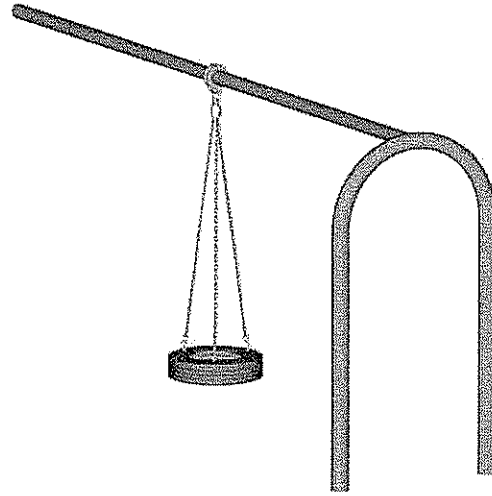

Arch Tire Swing & Extension

714-852, 714-852-X



Product Specifications

Kids' Choice®

Arch Swing Frames & Arch Swing Frame Extensions

714-852-2 & 714-852-2X

714-852-1H & 714-852-2HH

714-852-1HX & 714-852-2HHX

Arch Swing Frame*

(2) End Arches & (1) Header form (1) Bay for (2) Seats

Arch Swing Frame Extension*

(1) Extension Arch & (1) Header form (1) additional Bay for (2) additional Seats

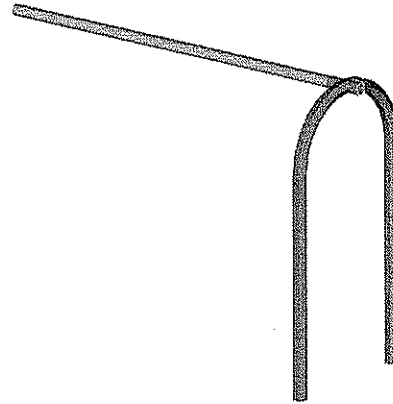
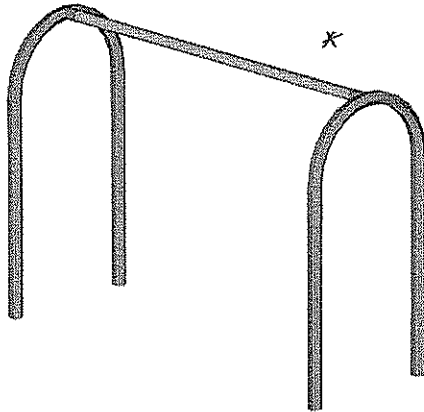

* Specifications for Model #s 714-852-2 and 714-852-2X encompass Model #s 714-852-4 and 714-852-6.

714-852-2 & 714-852-2X

714-852-1H & 714-852-2HH

714-852-1HX & 714-852-2HHX

Arch Swing Frame for Therapeutic Swing Seat

(2) End Arches & (1) Header form (1) Bay for (1) Therapeutic Swing Seat

Arch Swing Frame for Therapeutic Swing Seats

(2) End Arches & (1) Header form (1) Bay for (2) additional Therapeutic Swing Seats

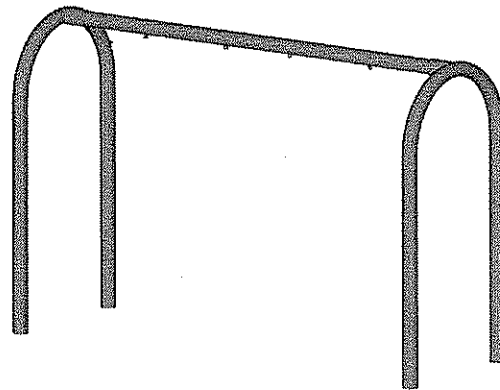
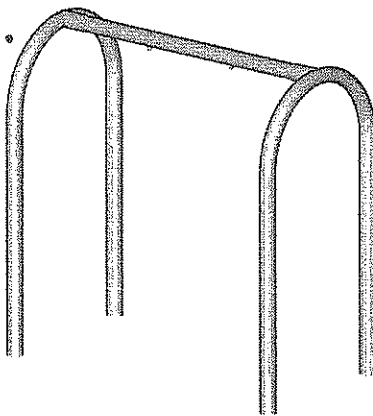

Arch Swing Frames & Extensions

714-852-2, 714-852-2X, 714-852-1H, 714-852-2HH, 714-852-1HX, 714-852-2HHX



Kids' Choice®

Arch Swing Frames & Arch Swing Frame Extensions

714-852-2 & 714-852-2X

714-852-1H & 714-852-2HH

714-852-1HX & 714-852-2HHX

Arch Swing Frame Extension for Therapeutic Swing Seat

(1) Extension Arch & (1) Header form (1) additional Bay for (1) additional Therapeutic Swing Seat

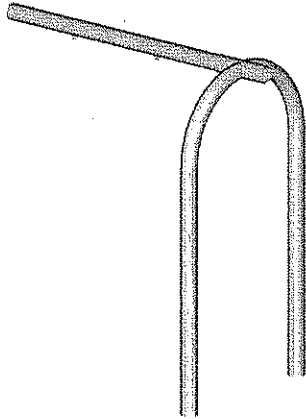

Arch Swing Frame Extension for Therapeutic Swing Seats

(1) Extension Arch & (1) Header form (1) additional Bay for (2) additional Therapeutic Swing Seats

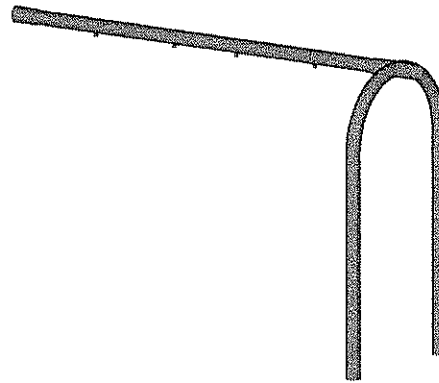

Arch Swing Frames & Extensions

714-852-2, 714-852-2X, 714-852-1H, 714-852-2HH, 714-852-1HX, 714-852-2HHX



Product Specifications

MIRACLE
RECREATION EQUIPMENT COMPANY

Whirl with Governor

303

Whirl

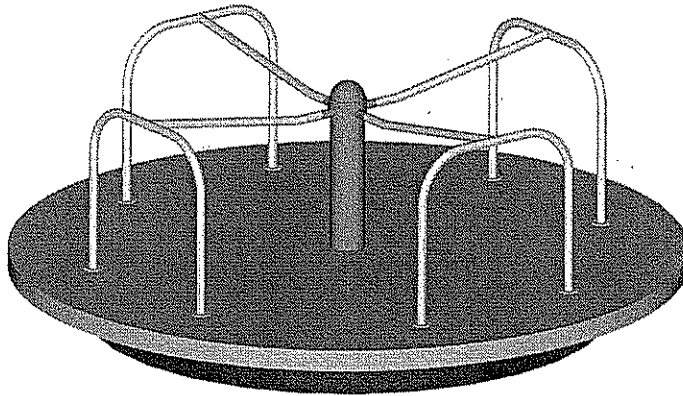

Whirl



Product Specifications

MIRACLE
RECREATION EQUIPMENT COMPANY

Peak Climber with Handrails - 2-Way, 3-Way & 4-Way & Add-ons

Peak Climber with Handrail & Add-ons

458-2

Peak Climber with Handrail,
2-Way

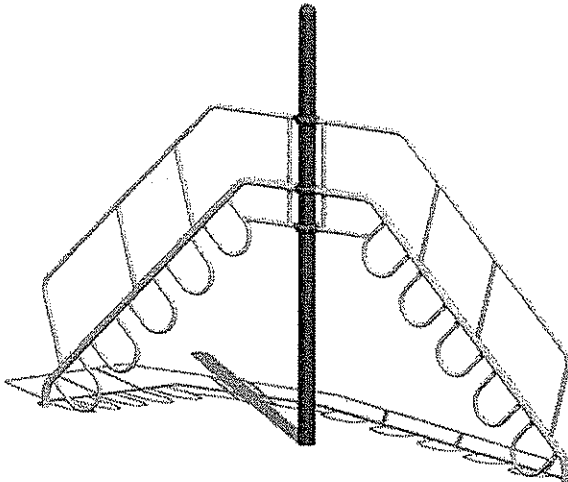

458-3

Peak Climber with Handrail,
3-Way

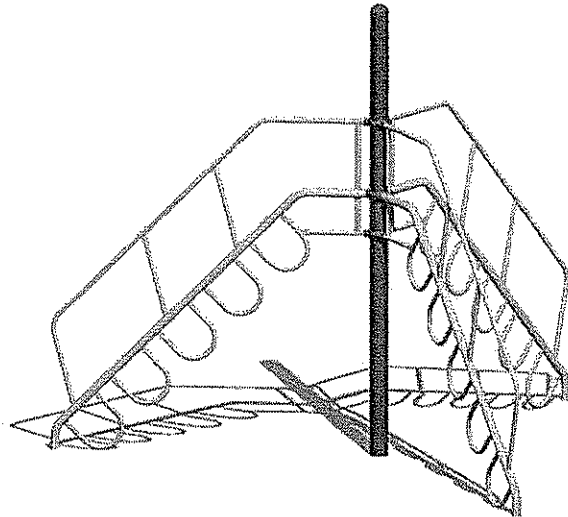

458-4

Peak Climber with Handrail,
4-Way

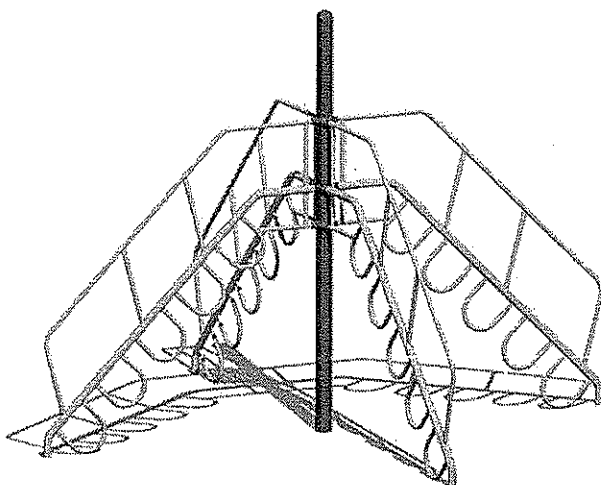

458-2A1

Peak Climber with Handrail,
2-Way with 1 Add-on

Note: Climber shown with Add-on 4582A-908.

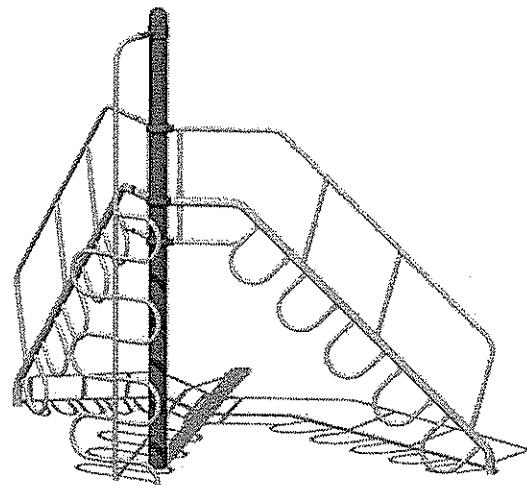

Peak Climber with Handrail & Add-ons

Peak Climber with Handrail - 2-Way, 3-Way & 4-Way; Climber Add-Ons

458-2A2

**Peak Climber with Handrail,
2-Way with 2 Add-ons**

Note: Climber shown with Add-ons 4582A-9695 & 4582A-721.

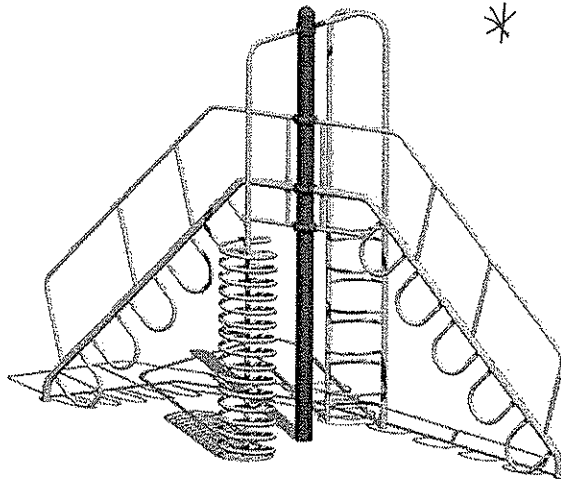



Product Specifications

MIRACLE
RECREATION EQUIPMENT COMPANY

Freestanding Typhoon Slides - Platform Heights of 6'-3", 9'-4" & 12'

Freestanding Typhoon Slides

65-748 and 65-749

Freestanding Typhoon Slide, 360°, 6'-3" Platform

Freestanding Typhoon Slide, 405°, 6'-3" Platform

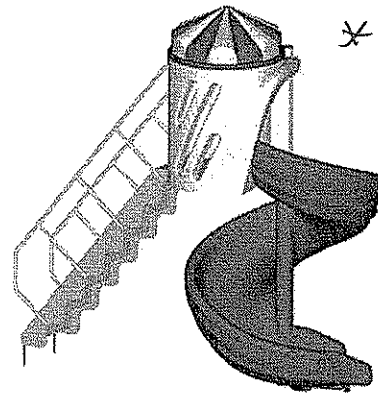

65-759 and 65-769

Freestanding Typhoon Slide, 630°, 9'-4" Platform

Freestanding Typhoon Slide, 855°, 12' Platform

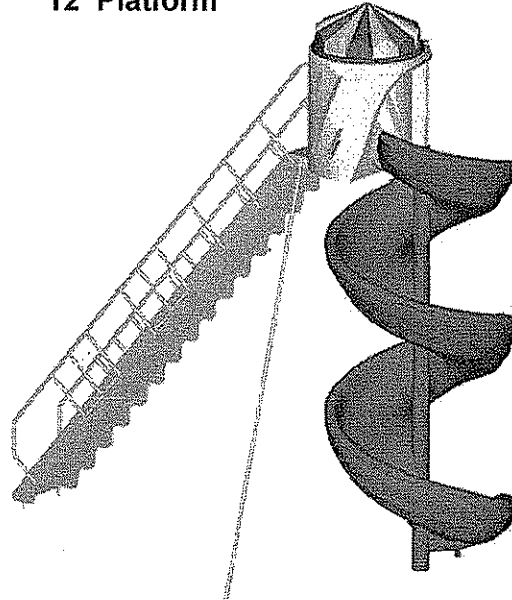
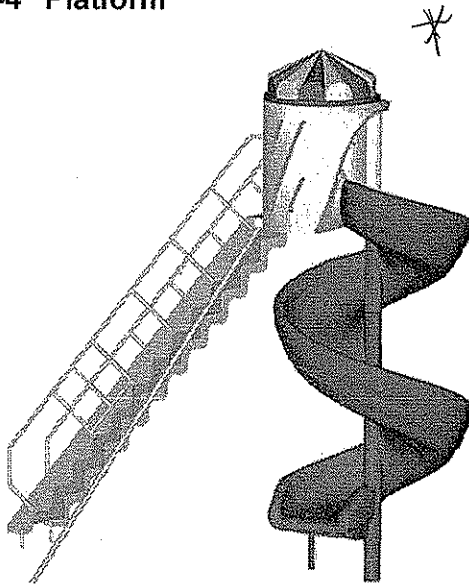

Twin Rider, Model #6081

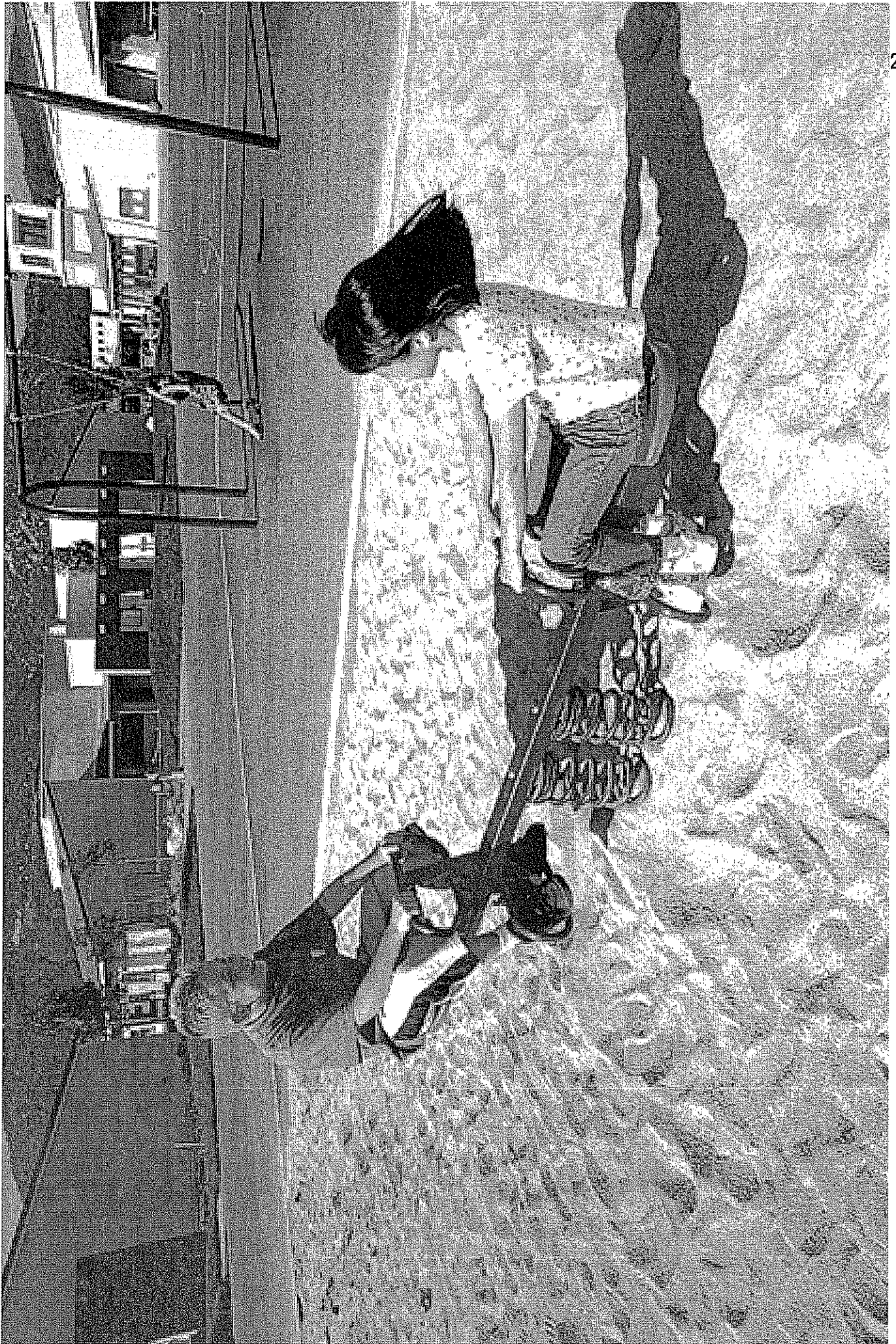



Product Specifications

MIRACLE Swing Seats RECREATION EQUIPMENT COMPANY

284, 2840 & 2841 ✕

Slashproof Seat

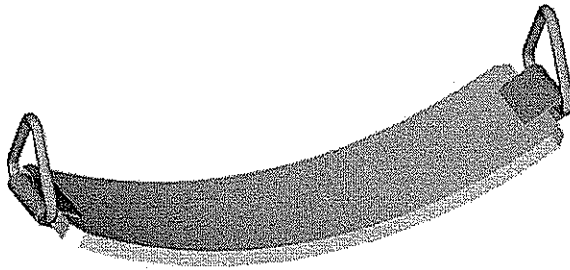

299 & 2990 ✕

360° Tot Seat

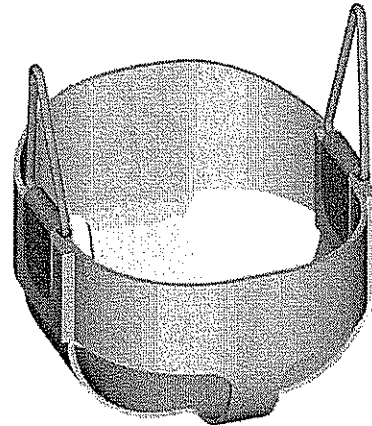

2720

Therapeutic Swing Seat

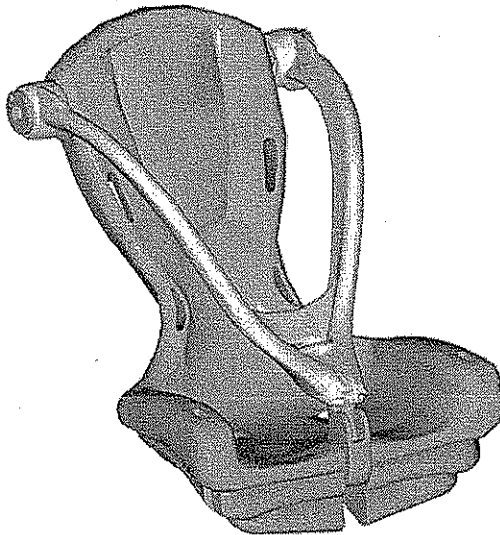

2721

Mirage Therapeutic Swing Seat

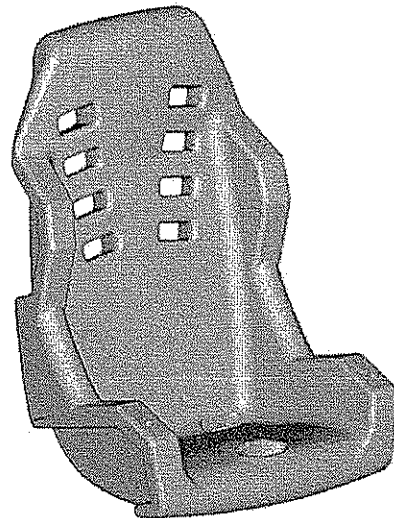

Swing Seats



Product Specifications

Kids' Choice®

Arch Swing Frames & Arch Swing Frame Extensions

714-852-2 & 714-852-2X

714-852-1H & 714-852-2HH

714-852-1HX & 714-852-2HHX

Arch Swing Frame*

(2) End Arches & (1) Header form (1) Bay for (2) Seats

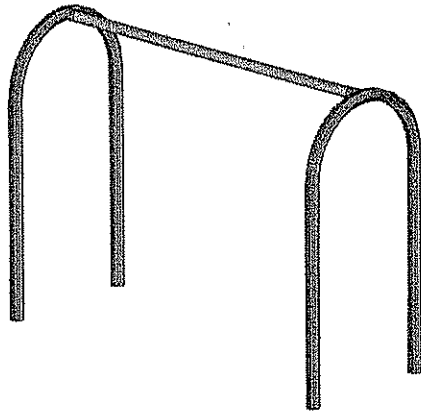

Arch Swing Frame Extension*

(1) Extension Arch & (1) Header form (1) additional Bay for (2) additional Seats

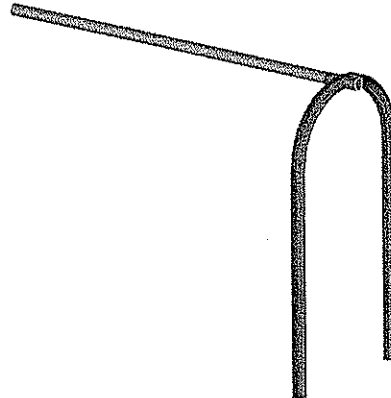

* Specifications for Model #s 714-852-2 and 714-852-2X encompass Model #s 714-852-4 and 714-852-6.

714-852-2 & 714-852-2X

714-852-1H & 714-852-2HH

714-852-1HX & 714-852-2HHX

Arch Swing Frame for Therapeutic Swing Seat

(2) End Arches & (1) Header form (1) Bay for (1) Therapeutic Swing Seat

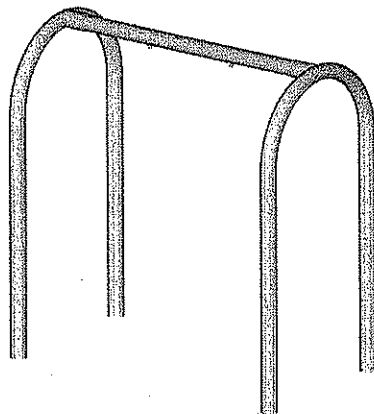

Arch Swing Frame for Therapeutic Swing Seats

(2) End Arches & (1) Header form (1) Bay for (2) additional Therapeutic Swing Seats

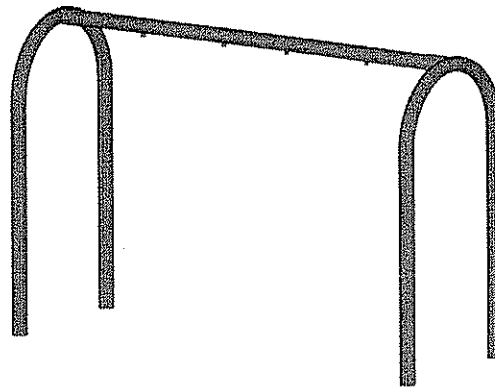

Arch Swing Frames & Extensions

714-852-2, 714-852-2X, 714-852-1H, 714-852-1HX, 714-852-2HH, 714-852-2HHX



Kids' Choice®

Arch Swing Frames & Arch Swing Frame Extensions

714-852-2 & 714-852-2X

714-852-1H & 714-852-2HH

714-852-1HX & 714-852-2HHX

Arch Swing Frame Extension for Therapeutic Swing Seat

- (1) Extension Arch & (1) Header form (1) additional Bay for
- (1) additional Therapeutic Swing Seat

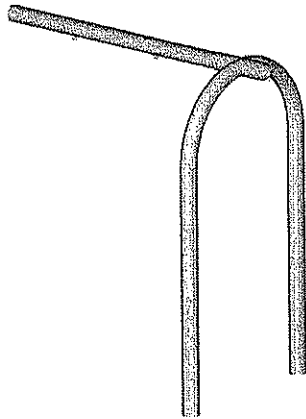

Arch Swing Frame Extension for Therapeutic Swing Seats

- (1) Extension Arch & (1) Header form (1) additional Bay for
- (2) additional Therapeutic Swing Seats

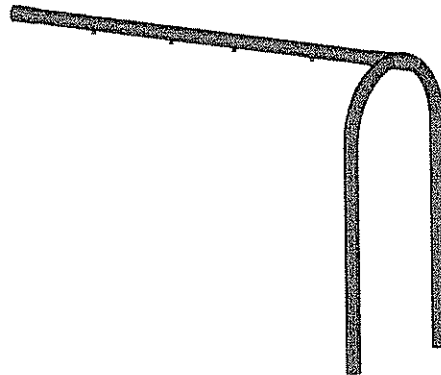

Arch Swing Frames & Extensions

714-852-2, 714-852-2X, 714-852-1H, 714-852-1HX, 714-852-2HH, 714-852-2HHX

STATE OF WEST VIRGINIA
Purchasing Division

PURCHASING AFFIDAVIT

VENDOR OWING A DEBT TO THE STATE:

West Virginia Code §5A-3-10a provides that: No contract or renewal of any contract may be awarded by the state or any of its political subdivisions to any vendor or prospective vendor when the vendor or prospective vendor or a related party to the vendor or prospective vendor is a debtor and the debt owed is an amount greater than one thousand dollars in the aggregate.

PUBLIC IMPROVEMENT CONTRACTS & DRUG-FREE WORKPLACE ACT:

If this is a solicitation for a public improvement construction contract, the vendor, by its signature below, affirms that it has a written plan for a drug-free workplace policy in compliance with Article 1D, Chapter 21 of the **West Virginia Code**. The vendor **must** make said affirmation with its bid submission. Further, public improvement construction contract may not be awarded to a vendor who does not have a written plan for a drug-free workplace policy in compliance with Article 1D, Chapter 21 of the **West Virginia Code** and who has not submitted that plan to the appropriate contracting authority in timely fashion. For a vendor who is a subcontractor, compliance with Section 5, Article 1D, Chapter 21 of the **West Virginia Code** may take place before their work on the public improvement is begun.

ANTITRUST:

In submitting a bid to any agency for the state of West Virginia, the bidder offers and agrees that if the bid is accepted the bidder will convey, sell, assign or transfer to the state of West Virginia all rights, title and interest in and to all causes of action it may now or hereafter acquire under the antitrust laws of the United States and the state of West Virginia for price fixing and/or unreasonable restraints of trade relating to the particular commodities or services purchased or acquired by the state of West Virginia. Such assignment shall be made and become effective at the time the purchasing agency tenders the initial payment to the bidder.

I certify that this bid is made without prior understanding, agreement, or connection with any corporation, firm, limited liability company, partnership or person or entity submitting a bid for the same materials, supplies, equipment or services and is in all respects fair and without collusion or fraud. I further certify that I am authorized to sign the certification on behalf of the bidder or this bid.

LICENSING:

Vendors must be licensed and in good standing in accordance with any and all state and local laws and requirements by any state or local agency of West Virginia, including, but not limited to, the West Virginia Secretary of State's Office, the West Virginia Tax Department, West Virginia Insurance Commission, or any other state agencies or political subdivision. Furthermore, the vendor must provide all necessary releases to obtain information to enable the Director or spending unit to verify that the vendor is licensed and in good standing with the above entities.

CONFIDENTIALITY:

The vendor agrees that he or she will not disclose to anyone, directly or indirectly, any such personally identifiable information or other confidential information gained from the agency, unless the individual who is the subject of the information consents to the disclosure in writing or the disclosure is made pursuant to the agency's policies, procedures and rules. Vendor further agrees to comply with the Confidentiality Policies and Information Security Accountability Requirements, set forth in <http://www.state.wv.us/admin/purchase/privacy/noticeConfidentiality.pdf>.

Under penalty of law for false swearing (**West Virginia Code** §61-5-3), it is hereby certified that the vendor affirms and acknowledges the information in this affidavit and is in compliance with the requirements as stated.

Vendor's Name: Taylor Sports + Recreation
Authorized Signature: Thomas C. Nelson Date: 5-5-09

State of West Virginia

VENDOR PREFERENCE CERTIFICATE

Certification and application* is hereby made for Preference in accordance with West Virginia Code, §5A-3-37. (Does not apply to construction contracts). West Virginia Code, §5A-3-37, provides an opportunity for qualifying vendors to request (at the time of bid) preference for their residency status. Such preference is an evaluation method only and will be applied only to the cost bid in accordance with the West Virginia Code. This certificate for application is to be used to request such preference. The Purchasing Division will make the determination of the Resident Vendor Preference, if applicable.

- 1. Application is made for 2.5% resident vendor preference for the reason checked: Bidder is an individual resident vendor and has resided continuously in West Virginia for four (4) years immediately preceding the date of this certification; or, Bidder is a partnership, association or corporation resident vendor and has maintained its headquarters or principal place of business continuously in West Virginia for four (4) years immediately preceding the date of this certification; or 80% of the ownership interest of Bidder is held by another individual, partnership, association or corporation resident vendor who has maintained its headquarters or principal place of business continuously in West Virginia for four (4) years immediately preceding the date of this certification; or, Bidder is a nonresident vendor which has an affiliate or subsidiary which employs a minimum of one hundred state residents and which has maintained its headquarters or principal place of business within West Virginia continuously for the four (4) years immediately preceding the date of this certification; or,
2. Application is made for 2.5% resident vendor preference for the reason checked: Bidder is a resident vendor who certifies that, during the life of the contract, on average at least 75% of the employees working on the project being bid are residents of West Virginia who have resided in the state continuously for the two years immediately preceding submission of this bid; or,
3. Application is made for 2.5% resident vendor preference for the reason checked: Bidder is a nonresident vendor employing a minimum of one hundred state residents or is a nonresident vendor with an affiliate or subsidiary which maintains its headquarters or principal place of business within West Virginia employing a minimum of one hundred state residents who certifies that, during the life of the contract, on average at least 75% of the employees or Bidder's affiliate's or subsidiary's employees are residents of West Virginia who have resided in the state continuously for the two years immediately preceding submission of this bid; or,
4. Application is made for 5% resident vendor preference for the reason checked: Bidder meets either the requirement of both subdivisions (1) and (2) or subdivision (1) and (3) as stated above; or,
5. Application is made for 3.5% resident vendor preference who is a veteran for the reason checked: Bidder is an individual resident vendor who is a veteran of the United States armed forces, the reserves or the National Guard and has resided in West Virginia continuously for the four years immediately preceding the date on which the bid is submitted; or,
6. Application is made for 3.5% resident vendor preference who is a veteran for the reason checked: Bidder is a resident vendor who is a veteran of the United States armed forces, the reserves or the National Guard, if, for purposes of producing or distributing the commodities or completing the project which is the subject of the vendor's bid and continuously over the entire term of the project, on average at least seventy-five percent of the vendor's employees are residents of West Virginia who have resided in the state continuously for the two immediately preceding years.

Bidder understands if the Secretary of Revenue determines that a Bidder receiving preference has failed to continue to meet the requirements for such preference, the Secretary may order the Director of Purchasing to: (a) reject the bid; or (b) assess a penalty against such Bidder in an amount not to exceed 5% of the bid amount and that such penalty will be paid to the contracting agency or deducted from any unpaid balance on the contract or purchase order.

By submission of this certificate, Bidder agrees to disclose any reasonably requested information to the Purchasing Division and authorizes the Department of Revenue to disclose to the Director of Purchasing appropriate information verifying that Bidder has paid the required business taxes, provided that such information does not contain the amounts of taxes paid nor any other information deemed by the Tax Commissioner to be confidential.

Under penalty of law for false swearing (West Virginia Code, §61-5-3), Bidder hereby certifies that this certificate is true and accurate in all respects; and that if a contract is issued to Bidder and if anything contained within this certificate changes during the term of the contract, Bidder will notify the Purchasing Division in writing immediately.

Bidder: Taylor Sports + Recreation Signed: Tom Nelson
Date: 5-5-09 Title: Regional Rep

*Check any combination of preference consideration(s) indicated above, which you are entitled to receive.



State of West Virginia
 Department of Administration
 Purchasing Division
 2019 Washington Street East
 Post Office Box 50130
 Charleston, WV 25305-0130

Request for Quotation

RFQ NUMBER
DNR209115

PAGE
1

ADDRESS CORRESPONDENCE TO ATTENTION OF
FRANK WHITTAKER
304-558-2316

RFQ COPY
 TYPE NAME/ADDRESS HERE
TAYLOR SPORTS + RECREATION
PO Box 1706
MARTINSBURG, WV 25402

DIVISION OF NATURAL RESOURCES
 BERWIND LAKE WMA
 ATTN: PARK SUPERINTENDENT
 POST OFFICE BOX 38
 WARRIORMINE, WV
 24894 875-4663

DATE PRINTED	TERMS OF SALE	SHIP VIA	FOB	FREIGHT TERMS
04/24/2009	30 DAY NET	Miracle Truck	DESTINATION	PREPAID/30 DAY NET
BID OPENING DATE	05/07/2009	BID OPENING TIME		01:30PM

LINE	QUANTITY	UOP	CAT NO	ITEM NUMBER	UNIT PRICE	AMOUNT
***** ADDENDUM NO. 1 *****						
THIS ADDENDUM IS ISSUED TO:						
1) REPLACE PRICING SHEET WITH THE ATTACHED REVISED PRICING SHEET WHICH ADDS LINE #16 GEO-TESTILE FABRIC						
2) REPLACE EQUIPMENT SHEET WITH THE ATTACHED REVISED EQUIPMENT SHEET WHICH ADDS LINE #16 GEO-TESTILE FABRIC						
3) PROVIDE THE MANDATORY PRE-BID SIGN IN SHEET.						
0001		LS		650-38		
PLAYGROUND EQUIPMENT (NOT OTHERWISE CLASSIFIED)						
***** THIS IS THE END OF RFQ DNR209115 ***** TOTAL:						<u>\$23,260.</u>

SEE REVERSE SIDE FOR TERMS AND CONDITIONS

SIGNATURE: Thomas C. Nelson TELEPHONE: 304-744-6548 DATE: 5-5-09

TITLE: Regional Rep FEIN: 55-0778347 ADDRESS CHANGES TO BE NOTED ABOVE

WHEN RESPONDING TO RFQ, INSERT NAME AND ADDRESS IN SPACE ABOVE LABELED 'VENDOR'

WARRANTY

Buyer agrees that products sold by
Miracle® Recreation Equipment Company
carry only the following warranty:

1. **LIMITED ONE HUNDRED (100) YEAR WARRANTY** on aluminum deck posts, steel deck posts, the Versalok® fastening system, and associated fastening hardware against structural failure caused by corrosion or deterioration from exposure to weather, or by defective materials or defective workmanship.
2. **LIMITED TWENTY-FIVE (25) YEAR WARRANTY** on the performance of Play Terrain™ Rubber Crumb Safety Surfacing.
3. **LIMITED FIFTEEN (15) YEAR WARRANTY** on steel support legs and Mira-Therm II on KIDS' CHOICE®, CENTER STAGE®, MEGA TOWER™, and TOTS' CHOICE® against structural failure caused by corrosion, defective materials, or defective workmanship.
4. **LIMITED FIFTEEN (15) YEAR WARRANTY** on playsystem steel components including railings, rungs, and rigid climbers against structural failure caused by defective materials or defective workmanship.
5. **LIMITED FIFTEEN (15) YEAR WARRANTY** on Rockite® against structural failure caused by defective materials or defective workmanship.
6. **LIMITED TEN (10) YEAR WARRANTY** on all Play Cover™ steel frames against failure due to corrosion, deterioration, or faulty workmanship.
7. **LIMITED EIGHT (8) YEAR WARRANTY** on Play Terrain™ Rubber Crumb color steadfastness.
8. **LIMITED FIVE (5) YEAR WARRANTY** on all Play Cover™ fabric due to rot, UV deterioration (shades of red are limited to 3 years), or defective workmanship.
9. **LIMITED FIVE (5) YEAR WARRANTY** on Kidrox™ Climbing Rocks and RAINBOW BEND™ and enclosed waterslide fiberglass sections against structural failure caused by defective materials or defective workmanship. Limited one (1) year warranty on all waterslide and pool slide support structures, stairways, landings, and railings against structural failure caused by defective materials or defective workmanship.
10. **LIMITED THREE (3) YEAR WARRANTY** on Slashproof Seats and 360° Bucket Tot Seats for swings against structural failure caused by defective materials or defective workmanship.
11. **LIMITED ONE (1) YEAR WARRANTY** on TODDLERS' CHOICE® main support materials and decks against structural failure caused by defective materials or defective workmanship.
12. **LIMITED ONE (1) YEAR WARRANTY** on bleachers against structural failure caused by defective materials or defective workmanship.
13. **LIMITED ONE (1) YEAR WARRANTY** on all products not listed above including all moving parts and flexible climbers against structural failure caused by defective materials or defective workmanship.
14. **LIMITED SIX (6) MONTH WARRANTY** on sewn fabric components on Early Childhood products.
15. These limited warranties do not include fading of colors (except on Play Cover™ and Play Terrain™ Rubber Crumb), damage due to excessive wear and tear, vandalism, or negligence. These warranties are valid only if products are installed according to manufacturer's installation instructions.
16. All warranties begin on the date of Miracle's invoice. Repaired or replacement part(s) are only warranted for the balance of the original limited warranty.

BUYER'S REMEDY If any of the products prove to be defective or non-conforming under normal operations within the above-prescribed warranty periods, Buyer must promptly notify Miracle in writing at P.O. Box 420, Monett, MO 65708 USA. Miracle will within a reasonable time repair or replace such defective or non conforming product by providing free of charge replacement part(s) to the site. Miracle will not be responsible for the cost of labor for the removal of nor the cost of labor for the installation of repaired or replacement part(s).

These limited warranties do not apply to structures not erected in conformity with Miracle's installation instructions, structures not maintained or inspected in conformity with Miracle's instructions, parts that have been modified, altered or misused, parts that have not been used as designed or intended, structures that have had parts added or substituted, damage or reduction in value due to vandalism, abnormal use, or abuse. Buyer, by acceptance and use of this warranty, agrees that it waives any rights it may have to claim or assert that this limited warranty fails of its essential purpose. Buyer agrees venue for any action shall be in Barry or Greene Counties in the State of Missouri.

Except as specifically stated herein, all warranties, express or implied, including but not limited to any implied warranty of MERCHANTABILITY or FITNESS FOR A PARTICULAR PURPOSE are hereby EXCLUDED. This warranty excludes any other liability other than expressly stated, including, without limitation, any incidental or consequential damages.



CERTIFICATE

ISSUE DATE: 5/3/2009

Berwind Lake WMA

In the interest of public playground safety, IPEMA provides a third-party certification service whereby Detroit Testing Laboratory, Inc. validates a manufacturer's certification of conformance to the ASTM F1487-07 (excluding sections 7.1.1, 10 and 12.6.1) Standard Consumer Safety Performance Specification for Playground Equipment for Public Use.

The manufacturer listed below has received written validation from Detroit Testing Laboratory, Inc. that the products listed below conform with the requirements of ASTM F1487-07 (excluding sections 7.1.1, 10 and 12.6.1).

Manufacturer

Miracle Recreation
P.O. Box 420.
Monett, MO 65708

PRODUCT #

714-852
714-852-2S

714-852-4

2840
2990
303

PRODUCT LINE

Kids' Choice
Kids' Choice
Kids' Choice

Misc
Misc
Misc

DESCRIPTION

ARCH TIRE SWING
5" OD ARCH FRAME W/2 S/P SEATS
MC
5" OD ARCH FRAM ONLY 4 SEATS
REQ MC
Slashproof Swing Seat
360 Degree Seat
WHIRL



IPEMA Certificate of Compliance

<u>PRODUCT #</u>	<u>PRODUCT LINE</u>	<u>DESCRIPTION</u>
456-1	Misc	TARANTULA CLIMBER
458-2A2	Misc	2-WAY PEAK CLIMBER W/HANDRAILS, ADD 2 CLIMBERS Twin Rider w/o character head
608-1	Misc	Typhoon Slide, Rockite (6' Platform)
65-749	Misc	TYPHOON SLIDE, 630 DEG W/PVC STEP (9'4"PLTFM)
918	Misc	SQUIRREL "C" SPRING RIDER
963	Misc	POKEY SNAIL "C" SPRING RIDER

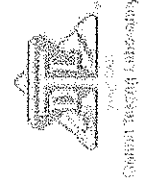

2 of 2 You may verify this certificate by visiting IPEMA's website at <http://www.ipema.org>

IPEMA Certificate of Compliance



CERTIFICATE

ISSUE DATE: 5/3/2009

Berwind Lake WMA

In the interest of public playground safety, IPEMA provides a third-party certification service whereby Detroit Testing Laboratory, Inc. validates a manufacturer's certification of conformance to the ASTM F1292-04, Standard Specification for Impact Attenuation of Surface Systems Under and Around Playground Equipment Standard. The

manufacturer listed below has received written validation from Detroit Testing Laboratory, Inc. that the products listed below conform with the requirements of ASTM F1292-04.

Manufacturer
Zeager Bros. Inc.
4000 East Harrisburg Pike,
Middletown, PA 17057
United States

PRODUCT #
08W
PRODUCT LINE
Woodcarpet

DESCRIPTION
8" Woodcarpet

THK/HT RATIO
8"/8'

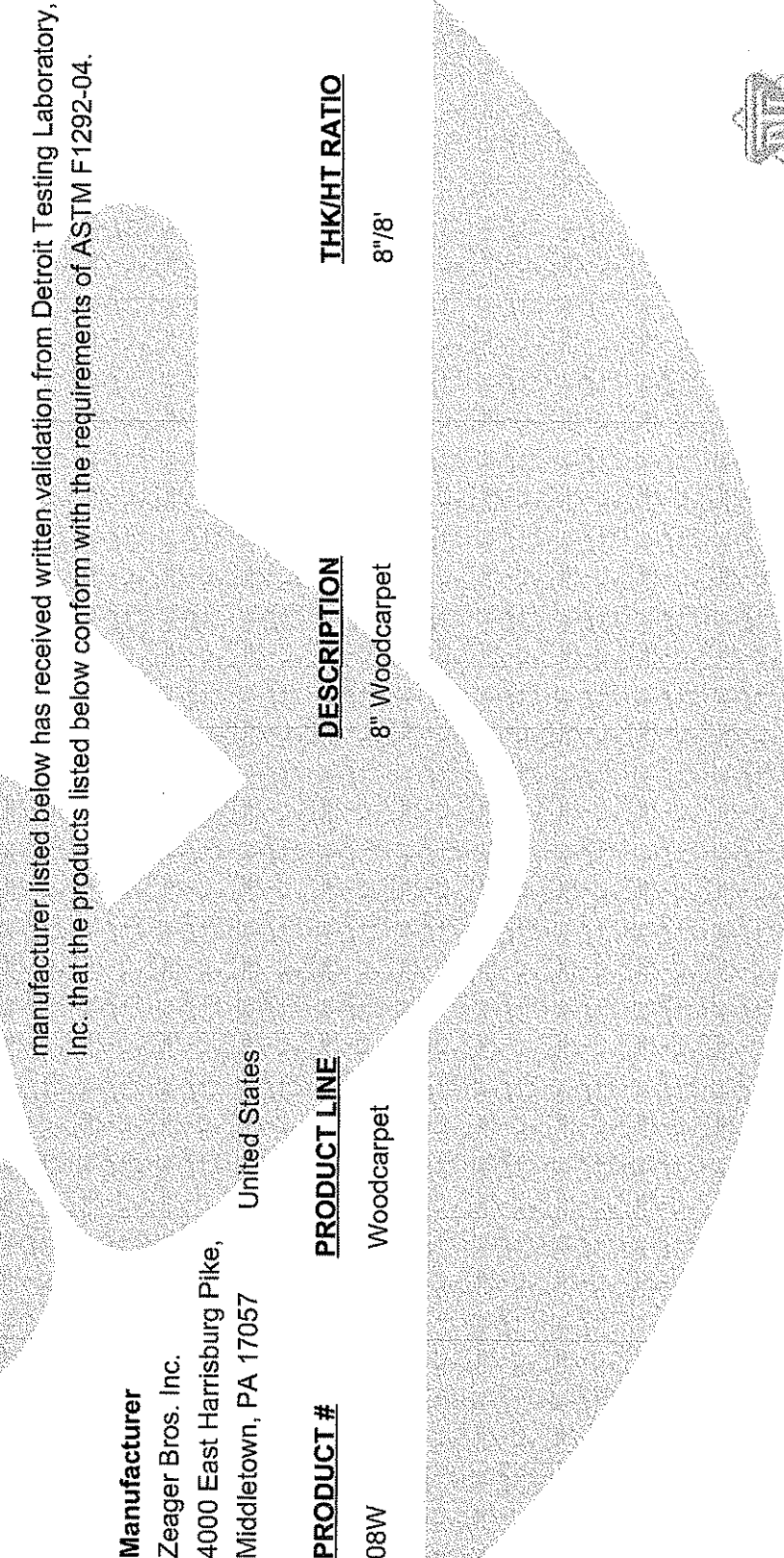

Detroit Testing Laboratory

1 of 1 You may verify this certificate by visiting IPEMA's website at <http://www.ipema.org>