



State of West Virginia
 Department of Administration
 Purchasing Division
 2019 Washington Street East
 Post Office Box 50130
 Charleston, WV 25305-0130

Request for Quotation

RFQ NUMBER
DNR209113

PAGE
1

ADDRESS CORRESPONDENCE TO ATTENTION OF
FRANK WHITTAKER 304-558-2316

VENDOR

*702142549 304-428-3000
 DAVIS ATHLETICS LLC
 2325 LIBERTY ST
 PARKERSBURG WV 26101

SHIP TO

DIVISION OF NATURAL RESOURCES
 NORTH BEND STATE PARK
 ATTN: PARK SUPERINTENDENT
 ROUTE 1, BOX 221
 CAIRO, WV 26337 304-643-2931

DATE PRINTED	TERMS OF SALE	SHIP VIA	F.O.B.	FREIGHT TERMS
03/20/2009				

BID OPENING DATE: 04/23/2009 BID OPENING TIME 01:30PM

LINE	QUANTITY	UOP	CAT NO.	ITEM NUMBER	UNIT PRICE	AMOUNT
0001	1	LS		650-38		
PLAYGROUND EQUIPMENT (NOT OTHERWISE CLASSIFIED)						
<p>THE WEST VIRGINIA PURCHASING DIVISION, FOR THE AGENCY, THE WEST VIRGINIA DIVISION OF NATURAL RESOURCES IS SOLICITING BIDS FROM RESPONSIBLE VENDORS FOR NEW PLAYGROUND EQUIPMENT FOR NORTH BEND STATE PARK PER THE ATTACHED SPECIFICATIONS.</p> <p>TECHNICAL QUESTIONS MAY BE SUBMITTED IN WRITING TO FRANK WHITTAKER VIA FAX AT 304-558-4115 OF VIA EMAIL AT FRANK.M.WHITTAKER@WV.GOV. DEADLINE FOR TECHNICAL QUESTIONS IS 04/08/2009 AT 4:00 PM</p> <p>A MANDATORY PRE-BID MEETING WILL BE HELD ON 04/02/09 AT 10:00 AT THE PARK HEADQUARTERS. FAILURE TO ATTEND THE MANDATORY PRE-BID MEETING WILL RESULT IN BID DISQUALIFICATION. AN INDIVIDUAL MAY NOT REPRESENT MORE THAN ONE FIRM AT THE PRE-BID MEETING.</p> <p>BANKRUPTCY: IN THE EVENT THE VENDOR/CONTRACTOR FILES FOR BANKRUPTCY PROTECTION, THIS CONTRACT MAY BE DEEMED NULL AND VOID, AND TERMINATED WITHOUT FURTHER ORDER.</p> <p>THE MODEL/BRAND/SPECIFICATIONS NAMED HEREIN ESTABLISH THE ACCEPTABLE LEVEL OF QUALITY ONLY AND ARE NOT INTENDED TO REFLECT A PREFERENCE OR FAVOR ANY PARTICULAR BRAND OR VENDOR. VENDORS WHO ARE BIDDING ALTERNATES SHOULD SO STATE AND INCLUDE PERTINENT LITERATURE AND SPECIFICATIONS. FAILURE TO PROVIDE INFORMATION FOR ANY ALTERNATES MAY BE GROUNDS FOR</p>						

RECEIVED
 2009 APR 23 A 10:01
 PURCHASING DIVISION
 STATE OF WV

SEE REVERSE SIDE FOR TERMS AND CONDITIONS			
SIGNATURE	TELEPHONE	DATE	
<i>Michael J Davis</i>	304-428-3000	4-22-09	
TITLE	FEIN	ADDRESS CHANGES TO BE NOTED ABOVE	
Owner	41-2171922		

WHEN RESPONDING TO RFQ, INSERT NAME AND ADDRESS IN SPACE ABOVE LABELED 'VENDOR'



State of West Virginia
 Department of Administration
 Purchasing Division
 2019 Washington Street East
 Post Office Box 50130
 Charleston, WV 25305-0130

Request for Quotation

RFQ NUMBER
DNR209113

PAGE
2

ADDRESS CORRESPONDENCE TO ATTENTION OF
FRANK WHITTAKER 304-558-2316

VENDOR

*702142549 304-428-3000
 DAVIS ATHLETICS LLC
 2325 LIBERTY ST

 PARKERSBURG WV 26101

SHIP TO

DIVISION OF NATURAL RESOURCES
 NORTH BEND STATE PARK
 ATTN: PARK SUPERINTENDENT
 ROUTE 1, BOX 221
 CAIRO, WV 26337 304-643-2931

DATE PRINTED	TERMS OF SALE	SHIP VIA	F.O.B.	FREIGHT TERMS
03/20/2009				

BID OPENING DATE: 04/23/2009 BID OPENING TIME 01:30PM

LINE	QUANTITY	UOP	CAT NO.	ITEM NUMBER	UNIT PRICE	AMOUNT
<p>REJECTION OF THE BID. THE STATE RESERVES THE RIGHT TO WAIVE MINOR IRREGULARITIES IN BIDS OR SPECIFICATIONS IN ACCORDANCE WITH SECTION 148-1-4(F) OF THE WEST VIRGINIA LEGISLATIVE RULES AND REGULATIONS.</p> <p>NOTICE</p> <p>A SIGNED BID MUST BE SUBMITTED TO:</p> <p>DEPARTMENT OF ADMINISTRATION PURCHASING DIVISION BUILDING 15 2019 WASHINGTON STREET, EAST CHARLESTON, WV 25305-0130</p> <p>THE BID SHOULD CONTAIN THIS INFORMATION ON THE FACE OF THE ENVELOPE OR THE BID MAY NOT BE CONSIDERED:</p> <p>SEALED BID</p> <p>BUYER: 44</p> <p>RFQ. NO.: DNR209122</p> <p>BID OPENING DATE: 04/23/2009</p> <p>BID OPENING TIME: 1:30 PM</p> <p>PLEASE PROVIDE A FAX NUMBER IN CASE IT IS NECESSARY TO CONTACT YOU REGARDING YOUR BID:</p>						

SEE REVERSE SIDE FOR TERMS AND CONDITIONS

SIGNATURE <i>Michael J Davis</i>	TELEPHONE 304-428-3000	DATE 4-22-09
TITLE Owner	FEIN 41-2171922	ADDRESS CHANGES TO BE NOTED ABOVE

WHEN RESPONDING TO RFQ, INSERT NAME AND ADDRESS IN SPACE ABOVE LABELED 'VENDOR'



State of West Virginia
 Department of Administration
 Purchasing Division
 2019 Washington Street East
 Post Office Box 50130
 Charleston, WV 25305-0130

Request for Quotation

RFQ NUMBER
 DNR209113

PAGE
 3

ADDRESS CORRESPONDENCE TO ATTENTION OF
 FRANK WHITTAKER
 304-558-2316

VENDOR

*702142549 304-428-3000
 DAVIS ATHLETICS LLC
 2325 LIBERTY ST
 PARKERSBURG WV 26101

SHIP TO

DIVISION OF NATURAL RESOURCES
 NORTH BEND STATE PARK
 ATTN: PARK SUPERINTENDENT
 ROUTE 1, BOX 221
 CAIRO, WV 26337 304-643-2931

DATE PRINTED	TERMS OF SALE	SHIP VIA	F.O.B.	FREIGHT TERMS
03/20/2009				

BID OPENING DATE: 04/23/2009 BID OPENING TIME 01:30PM

LINE	QUANTITY	UOP	CAT. NO.	ITEM NUMBER	UNIT PRICE	AMOUNT
<p>304-428-3002 (Fax)</p> <hr/> <p>CONTACT PERSON (PLEASE PRINT CLEARLY): Fred L Davis</p> <hr/> <p>***** THIS IS THE END OF RFQ DNR209113 ***** TOTAL: <u>\$42,800</u></p>						

SEE REVERSE SIDE FOR TERMS AND CONDITIONS

SIGNATURE <i>Fred L Davis</i>	TELEPHONE 304-428-3000	DATE 4-22-09
TITLE Owner	FEIN 41-2171922	ADDRESS CHANGES TO BE NOTED ABOVE

WHEN RESPONDING TO RFQ, INSERT NAME AND ADDRESS IN SPACE ABOVE LABELED 'VENDOR'

North Bend State Park Playground Specifications

To supply playground equipment to offer play activities for children ages five (5) to twelve (12) at North Bend State Park, Cairo, West Virginia. Playground equipment will be purchased for two separate areas in the park. Park personnel will install all playground equipment. The award may be split if it is in the best interest of the West Virginia Division of Natural Resources.

RECREATION AREA PLAYGROUND

PowerScape plus Fitness Fair, Model #85214, or equal. F.O.B. Destination. Freight or delivery charges must be included in the price of the goods. Delivery must be made within ninety (90) days of purchase order award.

PrimeTime swing frame, Item #12583, or equal. Frame must have a minimum of 3 1/2" OD. F.O.B. Destination. Freight or delivery charges must be included in the price of the goods. Delivery must be made within ninety (90) days of purchase order award.

PrimeTime swing add-a-bay, Item #12584, or equal. Frame must have a minimum of 3 1/2" OD. F.O.B. Destination. Freight or delivery charges must be included in the price of the goods. Delivery must be made within ninety (90) days of purchase order award.

PrimeTime 3 1/2" enclosed tot swing with galvanized chain, Item #8696, or equal. F. O. B. Destination. Freight or delivery charges must be included in the price of the goods. Delivery must be made within ninety (90) days of purchase order award.

PrimeTime 3 1/2" belt seat with galvanized chain, Item #8910, or equal. F.O.B. Destination. Freight or delivery charges must be included in the price of the goods. Delivery must be made within ninety (90) days of purchase order award.

GameTime tuffclad in-ground bench Model #28009, or equal. Bench must be a minimum of 6' in length and a minimum of 10" wide seat and minimum of 10" wide backrest. Must be constructed of galvanized steel with oven cured powder coating. F.O.B. Destination. Freight or delivery charges must be included in the price of the goods. Delivery must be made within ninety (90) days of purchase order award.

Geo-textile fabric, 2,250 sq. ft. roll or equal. F.O.B. Destination. Freight or delivery charges must be included in the price of the goods. Delivery must be made within ninety (90) days of purchase order award.

Geo-textile fabric, 1,125 sq. ft. roll, or equal. F.O.B. Destination. Freight or delivery charges must be included in the price of the goods. Delivery must be made within ninety (90) days of purchase order award.

North Bend State Park Playground Specifications

Engineered wood fiber @ 8" compacted depth. F.O.B. Destination. Freight or delivery charges must be included in the price of the goods. Delivery must be made within ninety (90) days of purchase order award.

One (1) day of supervision by successful vendor. Park personnel will install all playground equipment and this will provide oversight to ensure that all equipment is assembled and installed properly according to manufacturer's guidelines.

LODGE AREA PLAYGROUND

PrimeTime kid coral, Item #g11823, or equal. F.O.B. Destination. Freight or delivery charges must be included in the price of the goods. Delivery must be made within ninety (90) days of purchase order award.

PrimeTime swing frame, Item #12583, or equal. Swing must have a minimum of 3 1/2" OD. F.O.B. Destination. Freight or delivery charges must be included in the price of the goods. Delivery must be made within ninety (90) days of purchase order award.

PrimeTime swing-a-bay, item #12584, or equal. Swing must have a minimum of 3 1/2" OD. F.O.B. Destination. Freight or delivery charges must be included in the price of the goods. Delivery must be made within ninety (90) days of purchase order award.

PrimeTime 3 1/2" belt seat with galvanized chain, Item #8910, or equal. F.O.B. Destination. Freight or delivery charges must be included in the price of the goods. Delivery must be made within ninety (90) days of purchase order award.

PrimeTime 3 1/2" enclosed tot swing with galvanized chain, item #8696, or equal. F.O.B. Destination. Freight or delivery charges must be included in the price of the goods. Delivery must be made within ninety (90) days of purchase order award.

GameTime tuffclad in-ground bench Model #28009, or equal. Bench must be a minimum of 6' in length and a minimum of 10" wide seat and minimum of 10" wide backrest. Must be constructed of galvanized steel with oven cured powder coating. F.O.B. Destination. Freight or delivery charges must be included in the price of the goods. Delivery must be made within ninety (90) days of purchase order award.

Geo-textile fabric, 2,250 sq. ft. roll or equal. F.O.B. Destination. Freight or delivery charges must be included in the price of the goods. Delivery must be made within ninety (90) days of purchase order award.

Engineered wood fiber @ 8" compacted depth. F.O.B. Destination. Freight or delivery charges must be included in the price of the goods. Delivery must be made within ninety (90) days of purchase order award.

North Bend State Park Playground Specifications

One (1) day of supervision by successful vendor. Park personnel will install all playground equipment and this will provide oversight to ensure that all equipment is assembled and installed properly according to manufacturer's guidelines.

North Bend State Park Playground Specifications

All playground equipment and engineered wood fiber must meet the following requirements:

- Compliance with U.S. Consumer Product Safety Commission, Handbook for Public Playground Safety.
- Compliance with ASTM Standard F 1487.
- Compliance with Architectural and Transportation Barriers Compliance Board, Americans with Disabilities Act (ADA) Accessibility Guidelines for Buildings and Facilities; Play Areas.

Vendors must submit the following attachments:

- Complete manufacturer's parts specifications and warranties.
- Layout drawing to scale of the proposed play structure or equipment.
- ASTM and CPSC Statement of Compliance

Warranties:

- All equipment and engineered wood fiber must be guaranteed to be free of defects in workmanship and material for a minimum of one year from date of acceptance. However, if manufacturer warranty periods are longer than the required minimum one year warranty, those warranties shall apply.

Color scheme of equipment must be coordinated with North Bend State Park. Color of items will be selected from manufacturer's standard colors.

A mandatory pre-bid conference will be held on April 2, 2009, at North Bend State Park Headquarters at 10:00 a.m. A failure to attend the mandatory pre-bid conference will result in bid disqualification. An individual may not represent more than one firm at the pre-bid conference.

North Bend State Park

PLAYGROUND EQUIPMENT SHEET

Please complete the below information concerning the brand(s) of equipment being bid in relation to this project. If bidding "or equal" brands, please attach manufacturer's literature documenting that it meets the mandatory requirements stated in the specifications. Vendors should note the areas of the provided manufacturer's literature that adheres to the mandatory requirements outlined in the Request For Proposal.

Item No.	Equipment	Manufacturer	Model
1	Recreation Area Playground PowerScape plus Fitness Fair, Model #85214, or equal.	Henderson	B 300002R0
2	Recreation Area Playground PrimeTime swing frame, Item #12583, or equal.	Henderson	SW340
3	Recreation Area Playground PrimeTime swing add-a-bay, Item #12584, or equal.	Henderson	SW341
4	Recreation Area Playground PrimeTime 3 1/2" enclosed tot swing with galvanized chain, Item #8696, or equal.	Henderson	SS042
5	Recreation Area PrimeTime 3 1/2" belt seat with galvanized chain, Item #8910, or equal.	Henderson	SS043
6	Recreation Area Playground GameTime tuffclad in-ground bench, Model #28009, or equal.	Webcoat	B6WBRC5
7	Recreation Area Playground geotextile fabric, 2,250 sq. ft. roll or equal.		
8	Recreation Area Playground geotextile fabric, 1,125 sq. ft. roll or equal.		
9	Recreation Area Playground engineered wood fiber @ 8" compacted depth or equal.		

North Bend State Park

PLAYGROUND EQUIPMENT SHEET

Item No.	Equipment	Manufacturer	Model
10	Recreation Area Playground one (1) day of supervision by successful vendor. Park personnel will install all playground equipment and this will provide oversight to ensure that all equipment is assembled and installed properly according to manufacture's guidelines.		
11	Lodge Area Playground PrimeTime kid coral, Item #g11823, or equal.	Henderson	B00003RO
12	Lodge Area Playground PrimeTime swing frame, Item #12583, or equal.	Henderson	SW340
13	Lodge Area Playground PrimeTime swing-a-bay, item #12584, or equal.	Henderson	SW341
14	Lodge Area Playground PrimeTime 3 1/2" belt seat with galvanized chain, Item # 8910, or equal.	Henderson	SS043
15	Lodge Area Playground PrimeTime 3 1/2" enclosed tot swing with galvanized chain, item #8696, or equal.	Henderson	SS042
16	Lodge Area Playground GameTime tuffclad in-ground bench Model #28009, or equal.	Webcoat	B6WBRC5
17	Lodge Area Playground geo-textile fabric, 2,250 sq. ft. roll or equal.		
18	Lodge Area Playground engineered wood fiber @ 8" compacted depth or equal.		

North Bend State Park

PLAYGROUND EQUIPMENT SHEET

Item No.	Equipment	Manufacturer	Model
19	Lodge Area Playground one (1) day of supervision by successful vendor. Park personnel will install all playground equipment and this will provide oversight to ensure that all equipment is assembled and installed properly according to manufacture's guidelines.		

North Bend State Park Playground Equipment
PRICING SHEET

Item No.	Quantity	Description	Unit Price	Amount
1	1	Recreation Area Playground PowerScape plus Fitness Fair, Model #85214, or equal.		
2	1	Recreation Area Playground PrimeTime swing frame, Item #12583, or equal.		
3	1	Recreation Area Playground PrimeTime swing add-a-bay, Item #12584, or equal.		
4	2	Recreation Area Playground PrimeTime 3 1/2" enclosed tot swing with galvanized chain, Item #8696, or equal.		
5	2	Recreation Area PrimeTime 3 1/2" belt seat with galvanized chain, Item #8910, or equal.		
6	4	Recreation Area Playground GameTime tuffclad in-ground bench Model #28009, or equal.		
7	1	Recreation Area Playground geo-textile fabric, 2,250 sq. ft. roll or equal.		
8	1	Recreation Area Playground Geo-textile fabric, 1,125 sq. ft. roll, or equal.		
9	4,650 square feet	Recreation Area Playground engineered wood fiber @ 8" compacted depth or equal.		
10	1	Recreation Area Playground one (1) day of supervision by successful vendor. Park personnel will install all playground equipment and this will provide oversight to ensure that all equipment is assembled and installed properly according to manufacture's guidelines.		
11	1	Lodge Area Playground PrimeTime kid coral, Item #g11823, or equal.		

North Bend State Park Playground Equipment
PRICING SHEET

Item No.	Quantity	Description	Unit Price	Amount
12	1	Lodge Area Playground PrimeTime swing frame, Item #12583, or equal.		
13	1	Lodge Area Playground PrimeTime swing-a-bay, item #12584, or equal.		
14	2	Lodge Area Playground PrimeTime 3 1/2" belt seat with galvanized chain, Item # 8910, or equal.		
15	2	Lodge Area Playground PrimeTime 3 1/2" enclosed tot swing with galvanized chain, item #8696, or equal.		
16	1	Lodge Area Playground GameTime tuffclad in-ground bench Model #28009, or equal.		
17	1	Lodge Area Playground geo-textile fabric, 2,250 sq. ft. roll or equal.		
18	2,516 square feet	Lodge Area Playground engineered wood fiber @ 8" compacted depth or equal.		
19	1	Lodge Area Playground one (1) day of supervision by successful vendor. Park personnel will install all playground equipment and this will provide oversight to ensure that all equipment is assembled and installed properly according to manufacture's guidelines.		
		TOTAL		\$42,800

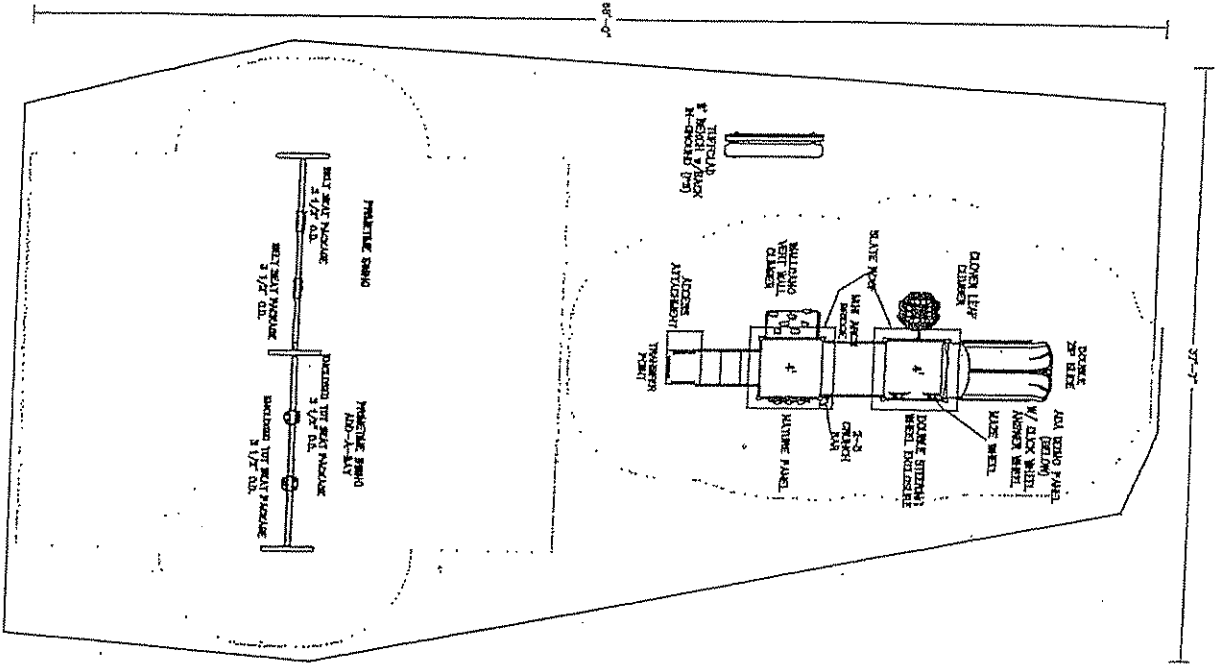

North Bend
Lodge Area
Daino, WV

No.	Revision	Date

This play equipment is recommended for children ages

Soft, resilient surfacing should be placed in the use zones of all equipment, as specified for each type of equipment, and it is to meet the critical fall heights as specified by the U.S. Consumer Product Safety Commission, ASTM standard F 1487 and Canadian Standard CAN/CSA Z-614.



Drawn By: SKK
 Date: _____
 Drawing Name: _____

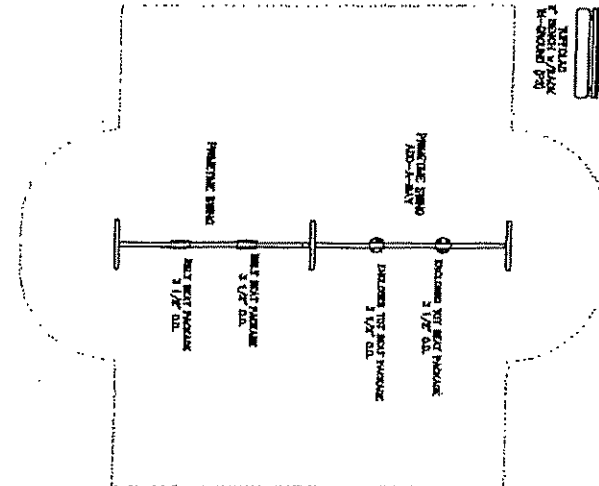
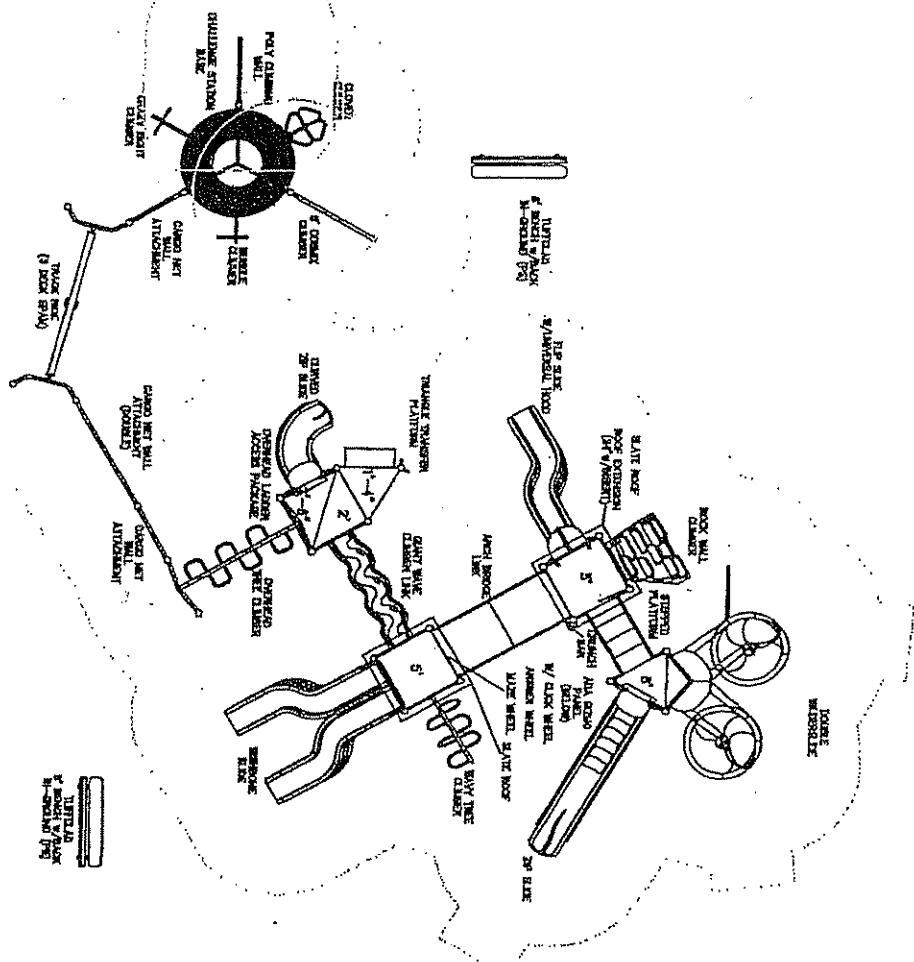

10'-0"

North Bend
Recreation Area
Cairo, WV

This play equipment is recommended for children ages

NOTE: Safety, resilient surfacing should be placed in the use areas of all equipment, as specified for each type of equipment, and at depths to meet the critical fall heights as specified by the U.S. Consumer Product Safety Commission, ASTM standard F 1487 and Canadian Standard CANCSA-Z-974.

Drawn By: _____
 Date: _____
 Drawing Name: _____





State of West Virginia
 Department of Administration
 Purchasing Division
 2019 Washington Street East
 Post Office Box 50130
 Charleston, WV 25305-0130

Request for Quotation

RFQ NUMBER
 DNR209113

PAGE
 1

ADDRESS CORRESPONDENCE TO ATTENTION OF:
 FRANK WHITTAKER
 304-558-2316

VENDOR
 *702142549 304-428-3000
 DAVIS ATHLETICS LLC
 2325 LIBERTY ST
 PARKERSBURG WV 26101

S H I P T O
 DIVISION OF NATURAL RESOURCES
 NORTH BEND STATE PARK
 ATTN: PARK SUPERINTENDENT
 ROUTE 1, BOX 221
 CAIRO, WV
 26337 304-643-2931

DATE PRINTED	TERMS OF SALE	SHIP VIA	F.O.B.	FREIGHT TERMS
03/23/2009				

BID OPENING DATE: 04/23/2009 BID OPENING TIME 01:30PM

LINE	QUANTITY	UOP	CAT. NO.	ITEM NUMBER	UNIT PRICE	AMOUNT
***** ADDENDUM NO. 1 *****						
THIS ADDENDUM IS ISSUED TO PROVIDE THE ATTACHED PURCHASING AFFIDAVIT FORM AND THE WV VENDOR PREFERENCE FORM WHICH WERE OMITTED FROM THE ORIGINAL RFQ.						
0001	1	LS		650-38		
PLAYGROUND EQUIPMENT (NOT OTHERWISE CLASSIFIED)						
***** THIS IS THE END OF RFQ DNR209113 ***** TOTAL:						<u>\$42,800</u>

SEE REVERSE SIDE FOR TERMS AND CONDITIONS

SIGNATURE *Med L Dams* TELEPHONE 304-428-3000 DATE 4-22-09
 TITLE Owner FEIN 41-2171922 ADDRESS CHANGES TO BE NOTED ABOVE

WHEN RESPONDING TO RFQ, INSERT NAME AND ADDRESS IN SPACE ABOVE LABELED 'VENDOR'

STATE OF WEST VIRGINIA
Purchasing Division

PURCHASING AFFIDAVIT

VENDOR OWING A DEBT TO THE STATE:

West Virginia Code §5A-3-10a provides that: No contract or renewal of any contract may be awarded by the state or any of its political subdivisions to any vendor or prospective vendor when the vendor or prospective vendor or a related party to the vendor or prospective vendor is a debtor and the debt owed is an amount greater than one thousand dollars in the aggregate.

PUBLIC IMPROVEMENT CONTRACTS & DRUG-FREE WORKPLACE ACT:

If this is a solicitation for a public improvement construction contract, the vendor, by its signature below, affirms that it has a written plan for a drug-free workplace policy in compliance with Article 1D, Chapter 21 of the **West Virginia Code**. The vendor **must** make said affirmation with its bid submission. Further, public improvement construction contract may not be awarded to a vendor who does not have a written plan for a drug-free workplace policy in compliance with Article 1D, Chapter 21 of the **West Virginia Code** and who has not submitted that plan to the appropriate contracting authority in timely fashion. For a vendor who is a subcontractor, compliance with Section 5, Article 1D, Chapter 21 of the **West Virginia Code** may take place before their work on the public improvement is begun.

ANTITRUST:

In submitting a bid to any agency for the state of West Virginia, the bidder offers and agrees that if the bid is accepted the bidder will convey, sell, assign or transfer to the state of West Virginia all rights, title and interest in and to all causes of action it may now or hereafter acquire under the antitrust laws of the United States and the state of West Virginia for price fixing and/or unreasonable restraints of trade relating to the particular commodities or services purchased or acquired by the state of West Virginia. Such assignment shall be made and become effective at the time the purchasing agency tenders the initial payment to the bidder.

I certify that this bid is made without prior understanding, agreement, or connection with any corporation, firm, limited liability company, partnership or person or entity submitting a bid for the same materials, supplies, equipment or services and is in all respects fair and without collusion or fraud. I further certify that I am authorized to sign the certification on behalf of the bidder or this bid.

LICENSING:

Vendors must be licensed and in good standing in accordance with any and all state and local laws and requirements by any state or local agency of West Virginia, including, but not limited to, the West Virginia Secretary of State's Office, the West Virginia Tax Department, West Virginia Insurance Commission, or any other state agencies or political subdivision. Furthermore, the vendor must provide all necessary releases to obtain information to enable the Director or spending unit to verify that the vendor is licensed and in good standing with the above entities.

CONFIDENTIALITY:

The vendor agrees that he or she will not disclose to anyone, directly or indirectly, any such personally identifiable information or other confidential information gained from the agency, unless the individual who is the subject of the information consents to the disclosure in writing or the disclosure is made pursuant to the agency's policies, procedures and rules. Vendor further agrees to comply with the Confidentiality Policies and Information Security Accountability Requirements, set forth in <http://www.state.wv.us/admin/purchase/privacy/noticeConfidentiality.pdf>.

Under penalty of law for false swearing (**West Virginia Code §61-5-3**), it is hereby certified that the vendor affirms and acknowledges the information in this affidavit and is in compliance with the requirements as stated.

Vendor's Name: Davis Athletics, LLC

Authorized Signature: Neal J Davis Date: 4-22-09

State of West Virginia VENDOR PREFERENCE CERTIFICATE

Certification and application* is hereby made for Preference in accordance with *West Virginia Code*, §5A-3-37. (Does not apply to construction contracts). *West Virginia Code*, §5A-3-37, provides an opportunity for qualifying vendors to request (at the time of bid) preference for their residency status. Such preference is an evaluation method only and will be applied only to the cost bid in accordance with the *West Virginia Code*. This certificate for application is to be used to request such preference. The Purchasing Division will make the determination of the Resident Vendor Preference, if applicable.

1. Application is made for 2.5% resident vendor preference for the reason checked:

- Bidder is an individual resident vendor and has resided continuously in West Virginia for four (4) years immediately preceding the date of this certification; or,
- Bidder is a partnership, association or corporation resident vendor and has maintained its headquarters or principal place of business continuously in West Virginia for four (4) years immediately preceding the date of this certification; or 80% of the ownership interest of Bidder is held by another individual, partnership, association or corporation resident vendor who has maintained its headquarters or principal place of business continuously in West Virginia for four (4) years immediately preceding the date of this certification; or,
- Bidder is a nonresident vendor which has an affiliate or subsidiary which employs a minimum of one hundred state residents and which has maintained its headquarters or principal place of business within West Virginia continuously for the four (4) years immediately preceding the date of this certification; or,

2. Application is made for 2.5% resident vendor preference for the reason checked:

- Bidder is a resident vendor who certifies that, during the life of the contract, on average at least 75% of the employees working on the project being bid are residents of West Virginia who have resided in the state continuously for the two years immediately preceding submission of this bid; or,

3. Application is made for 2.5% resident vendor preference for the reason checked:

- Bidder is a nonresident vendor employing a minimum of one hundred state residents or is a nonresident vendor with an affiliate or subsidiary which maintains its headquarters or principal place of business within West Virginia employing a minimum of one hundred state residents who certifies that, during the life of the contract, on average at least 75% of the employees or Bidder's affiliate's or subsidiary's employees are residents of West Virginia who have resided in the state continuously for the two years immediately preceding submission of this bid; or,

4. Application is made for 5% resident vendor preference for the reason checked:

- Bidder meets either the requirement of both subdivisions (1) and (2) or subdivision (1) and (3) as stated above; or,

5. Application is made for 3.5% resident vendor preference who is a veteran for the reason checked:

- Bidder is an individual resident vendor who is a veteran of the United States armed forces, the reserves or the National Guard and has resided in West Virginia continuously for the four years immediately preceding the date on which the bid is submitted; or,

6. Application is made for 3.5% resident vendor preference who is a veteran for the reason checked:

- Bidder is a resident vendor who is a veteran of the United States armed forces, the reserves or the National Guard, if, for purposes of producing or distributing the commodities or completing the project which is the subject of the vendor's bid and continuously over the entire term of the project, on average at least seventy-five percent of the vendor's employees are residents of West Virginia who have resided in the state continuously for the two immediately preceding years.

Bidder understands if the Secretary of Revenue determines that a Bidder receiving preference has failed to continue to meet the requirements for such preference, the Secretary may order the Director of Purchasing to: (a) reject the bid; or (b) assess a penalty against such Bidder in an amount not to exceed 5% of the bid amount and that such penalty will be paid to the contracting agency or deducted from any unpaid balance on the contract or purchase order.

By submission of this certificate, Bidder agrees to disclose any reasonably requested information to the Purchasing Division and authorizes the Department of Revenue to disclose to the Director of Purchasing appropriate information verifying that Bidder has paid the required business taxes, provided that such information does not contain the amounts of taxes paid nor any other information deemed by the Tax Commissioner to be confidential.

Under penalty of law for false swearing (*West Virginia Code*, §61-5-3), Bidder hereby certifies that this certificate is true and accurate in all respects; and that if a contract is issued to Bidder and if anything contained within this certificate changes during the term of the contract, Bidder will notify the Purchasing Division in writing immediately.

Bidder: Davis Athletics, LLC Signed: Neal L Davis
 Date: 4-22-09 Title: Owner

*Check any combination of preference consideration(s) indicated above, which you are entitled to receive.

PlaySteel Fit/Max Playsystems: Unit-Built, 3.5" Modular & 5" Modular

Product and Coating Specifications

Steel Component Specifications:

All round steel tubing shall be in-line galvanized and tested in compliance with ASTM-A500, ASTM-A-135, or ASTM-A-513 standards.

Unit-Built System: Square Posts – 4.00" x 4.00" x 0.125" wall (11 ga.), *in-line galvanized steel*
Mechanical Properties: 50,000 psi yield / 55,000 psi tensile strength

3.5" Modular System: Round Posts – 3.50" O.D. x 0.095" wall (13 ga.), *in-line galvanized steel*
Mechanical Properties: 45,000 psi yield / 48,000 psi tensile strength

5" Modular System: Round Posts – 5.00" O.D. x 0.120" wall (11 ga.), *in-line galvanized steel*
Mechanical Properties: 45,000 psi yield / 48,000 psi tensile strength

Post Caps and Modular System Clamps – Aluminum Alloy SAE 413

Typical Handrails – 1.3125" O.D. x 11 ga. or 14 ga. wall and 1" x 0.75" Oval x 15 ga., *In-line galvanized steel*

Stringer Channels – 4" x 1.5" x 3/16" G40.21 iron

Platforms and Deck Surfaces – 12 ga. perforated sheet steel

Plastic Component Specifications:

Polyethylene for rotationally molded or sheet components shall have ultraviolet (UV) stabilizers and colour pigment molded in. This material shall be tested in compliance with ASTM Test Method D1248, Type 2, Class A, and Federal Specifications LP-390C, Type 1, Class M, Grade 2, Category 3, and rotationally molded items shall have an average wall thickness of .25" (6.4mm).

Fastener Specifications:

All bolts, nuts, screws, and washers shall be either zinc plated, di-chromate washed, or stainless steel. All necessary fasteners shall be supplied.

Polyester Powder Coated Items:

Steel shall receive premium galvanic rust inhibiting treatments and an electrostatically applied polyester powder coating. The coating shall be cured at temperatures between 400 degrees F (204 degrees C) and 450 degrees F (232 degrees C). The polyester powder shall be tested in compliance with ASTM standards: D522 Flexibility Mandrel Test, D2794 Impact Resistance Test, B117 Salt Spray Resistance Test, D2247 Humidity Resistance Test, D3363 Pencil Hardness Test, D3359 Method B Crosshatch Adhesion Test. Such testing demonstrates the superior weatherability characteristics of polyester powder coating over epoxy or hybrid paints.

Steel items without In-Line Galvanized Coatings shall receive a Zinc-Rich Epoxy Primer prior to Polyester Powder Coating. This only applies to a relatively small range of components that utilize non-standard tubing sizes.

Plastisol Coatings:

Thickness shall average approximately 1/8" (3.2 mm) providing a safe, resilient surface

Polyethylene Coatings:

Thickness shall average approximately 1/16" (2 mm) providing more durability than plastisol yet still retaining resilience.

BELAIR has endeavoured to ensure that all specifications and representations of products provided in this catalogue were accurate at time of publication. BELAIR reserves the right to improve, alter or discontinue any item without notice. As a result, some items may not be exactly as depicted or specified.

DIN Compliance: Note: All BELAIR playground related products are designed to be installed over a protective surface.

CSA Compliance:

Products manufactured after 2003 are designed to comply with CSA Standard CAN/CSA-Z614-03, Children's Playspaces and Equipment.

All components are designed to comply with CSA Requirements and are periodically tested for Structural Integrity as per CSA Sections: 9.2 Stability, 9.3 Load Testing Criteria, 9.4 Strength of Swing Components and Structures, 9.5 Vertical Loads, 9.6.2 Accidental Concentrated Load (Lateral Force of 2000 Newtons), and 9.6.3 Lateral Surge Load.

This standard is published by the CSA (Canadian Standards Association). A copy of this Standard can be ordered by calling (416) 747-4044, or by contacting the nearest CSA office.

ASTM Testing Parameters

STRUCTURAL SQUARE AND RECTANGULAR TUBING ASTM A-500 GRADES B AND C

ASTM A-500 is a cold formed electric weld product. Advantages include material strength, ability to resist stress from any direction, and ease of connection to other structural shapes.

CHEMICAL COMPOSITION CHECK ANALYSIS		
Max. Percent	ASTM A-500 Grade B	ASTM A-500 Grade C
Carbon	0.30	0.27
Phosphorus	0.045	0.045
Sulphur	0.045	0.045

WORKABILITY AND WELDABILITY

Can be subjected to most of the usual fabricating operations. Its ductility is good, bends well, flattens, cuts, punches, flares, and flanges easily. Can also be welded by commonly employed techniques and practices.

MECHANICAL PROPERTIES		
	ASTM	
	A-500 Grade B	Grade C
Tensile Strength, min, psi	58,000	62,000
Yield Strength, min, psi	46,000	50,000
Elongation in 2 inch, min, percent	23	21

STRUCTURAL SQUARE AND RECTANGULAR TUBING MAXIMUM OUTSIDE CORNER RADII TOLERANCES

10.6 Radius of Corners—For square or rectangular structural tubing, the radius of any outside corner of the section shall not exceed three times the specified wall thickness.

OUTSIDE DIMENSIONS AND WALL THICKNESS SQUARE AND RECTANGULAR		
Largest Outside Dimension Across Flats, Inches	Tolerance for Outside Dimensions Including Convexity or Concavity	Wall Thickness Tolerance
1 to 2-1/2 incl.	Plus or minus 0.020"	Plus or minus 10% Exclusive of weld area
Over 2-1/2 to 3-1/2 incl.	Plus or minus 0.025"	Plus or minus 10% Exclusive of weld area
Over 3-1/2 to 5-1/2 incl	Plus or minus 0.030"	Plus or minus 10% Exclusive of weld area
Over 5-1/2	Plus or minus 1%	Plus or minus 10% Exclusive of weld area

NOTE: The allowable variation in wall thickness does not apply at corners.

A500 ROUND OD AND WALL TOLERANCES

1.900" and smaller OD: ±1/2%
 2.000 and larger OD: ±3/4%
WALL THICKNESS ±10%

TOLERANCES			
SQUARENESS OF SIDES			
Adjacent sides of structural hollows may deviate from 90° by plus or minus two degrees maximum.			
VARIATIONS FROM EXACT STRAIGHTNESS			
Permissible Variations, In. (Includes Camber and Sweep) 1/8" x 5		Number of Feet of Total Length 5	
MAXIMUM TWIST			
Longer Outside Dimensions, Inches		Maximum Twist Per 3 Feet of Length, Inches	
1 to 1-1/2 incl.		0.050	
Over 1-1/2 to 2-1/2 incl.		0.062	
Over 2-1/2 to 4 incl.		0.075	
Over 4 to 6 incl.		0.087	
Over 6 to 8 incl.		0.100	
Over 8		0.112	
Twist is measured by holding down the edge of one end of a square or rectangular structural hollow on a surface plate with the bottom side of the tube parallel to the surface plate and noting the height that either corner on the opposite end of the bottom side is above the surface plate.			
PERMISSIBLE VARIATION — MILL LENGTHS			
To 22' incl.		Over 22' to 44' incl.	
Over	Under	Over	Under
1/2"	1/4"	3/4"	1/4"

Cut lengths of stock material can normally be held within 1/8 in. or closer if desired.

North Bend State Park - Lodge Area

Model No. B300003R0

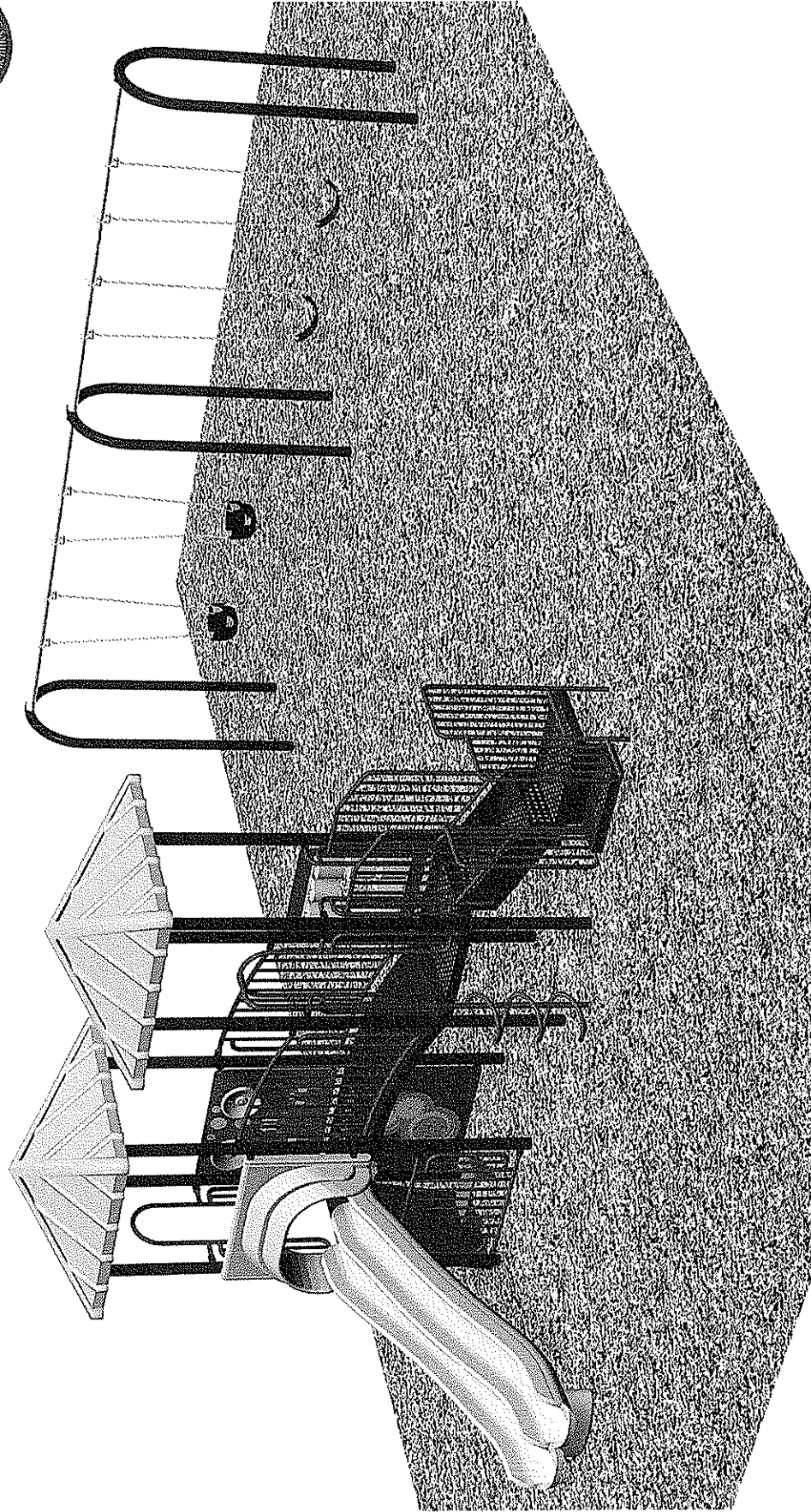

Powder-Coated Metal Colours

At least 20mm from any sharp edge

HDPE Colours

Roto-Molded Plastic Colours





North Bend State Park - Lodge Area

Model No. B300003R0

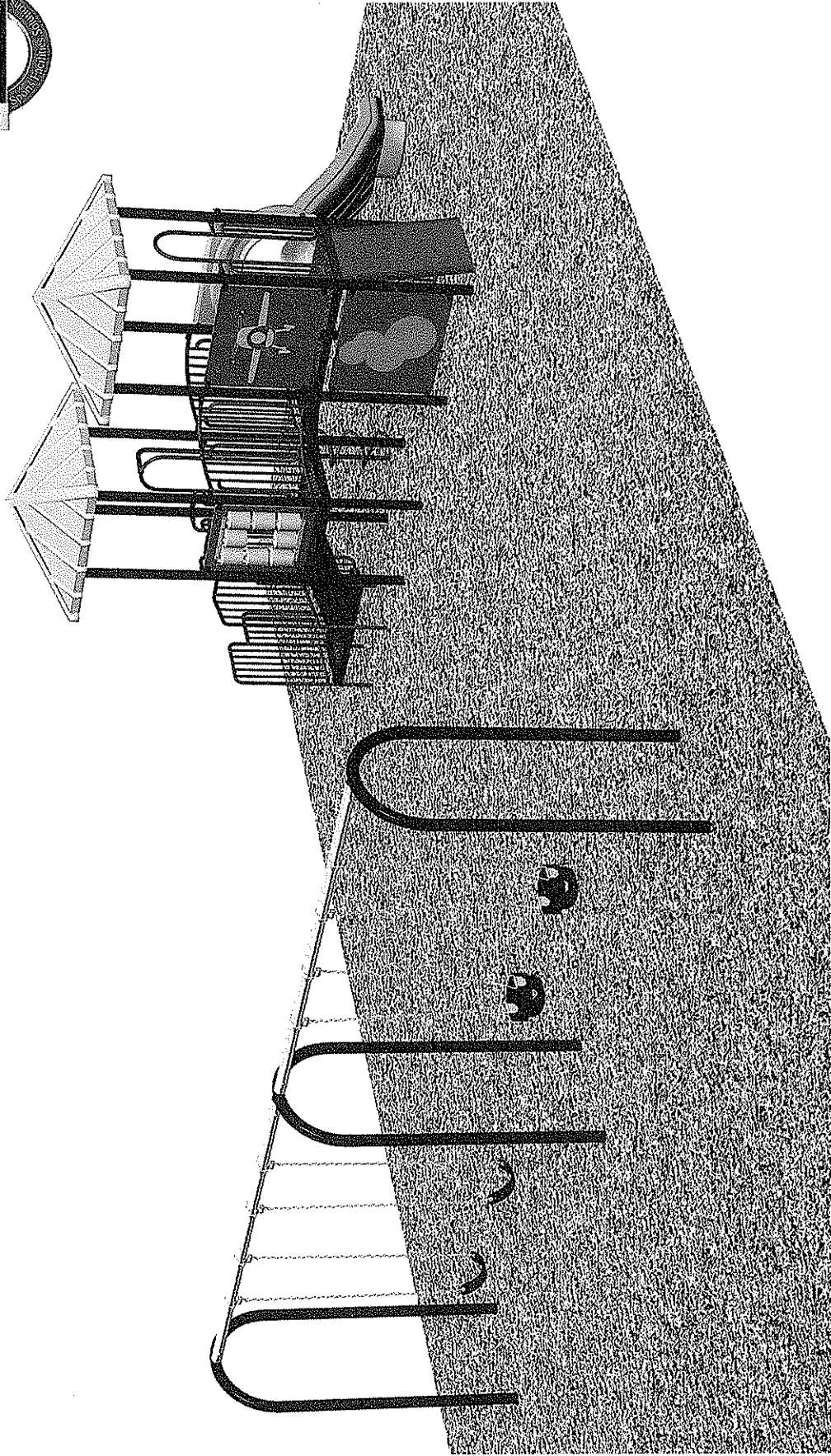

- Powder-Coated Metal Colours**
- Red
 - Orange
 - Yellow
 - Light
 - Teal
 - Green
 - Blue
 - Violet
 - Purple
 - Pinkish
 - Black
 - White

- HDPE Colours**
- Black
 - White
 - Grey
 - Light
 - Dark
 - Blue
 - Green
 - Yellow
 - Orange
 - Red
 - Purple
 - Pink
 - Teal
 - Light
 - Dark

- Roto-Molded Plastic Colours**
- Black
 - White
 - Grey
 - Light
 - Dark
 - Blue
 - Green
 - Yellow
 - Orange
 - Red
 - Purple
 - Pink
 - Teal
 - Light
 - Dark



Model # B300003R0

Davis Athletics
North Bend State Park - Lodge Area

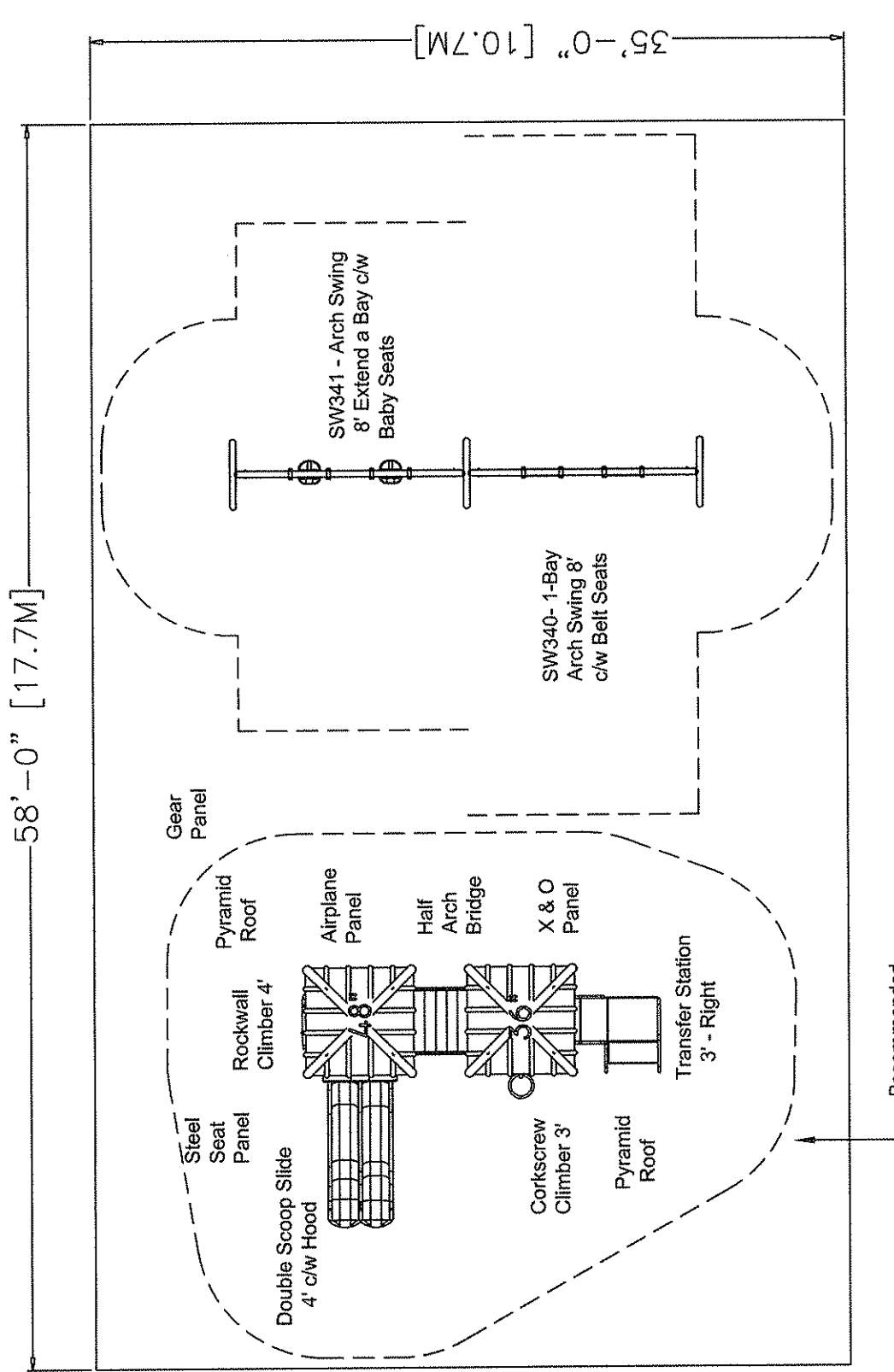
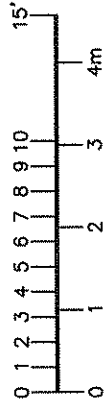

WARNING
Installation Over A Hard Surface Such As Concrete, Asphalt Or Pavement May Cause Injury To Children From Falls. Use Appropriate Fall Protection For Each Child.

Best User Age: 5 to 12

Accessibility: Yes

Colour:

Posts: Brown
Accent: Green
Roto Plastic: Tan
Other: Tan/Green

Surfacing Type: Wood Chips

Border Area: 2030

Border Perimeter: 186

Installation Style: Inground 36"

Footings Quantity: 0

Compliance: ASTM F 1487, CPSC

Sales Repr: F.D.

Note: All border dimensions are inside border measurements. All play structure dimensions are centre-to-centre of the posts unless otherwise specified. The locations of all telephone, hydro, cable, water, gas, and drainage lines must be clearly marked by the customer prior to the playground installation.

All playgrounds must be installed with appropriate resilient surfacing and safety zones to meet the required guidelines of the latest CAN/CSA-2614 (CAN) or ASTM F 1487 (USA) releases. The playground installation site must be properly prepared to Henderson Recreation. Henderson Recreation assumes the responsibility for ensuring the site has normal soil and digging conditions. Please notify us of any unusual soil conditions. Henderson Recreation Equipment Limited has a commitment to continuous product development and improvement and therefore reserves the right to improve, alter or discontinue products and specifications without notice.

*Attention: No-encroachment zones that are adjacent to but outside of the safety surface area must be free of any obstacles that would impede or block safe pedestrian traffic flow around the safety surface area. No-encroachment zones that are within the safety surface area must be free of all obstacles.

Drawn By: R.H.
Date Drawn: April 6, 2009
Revised By:
Revision Date:
Scale: See Key





North Bend State Park - Recreation Area

Model No. B300002R0

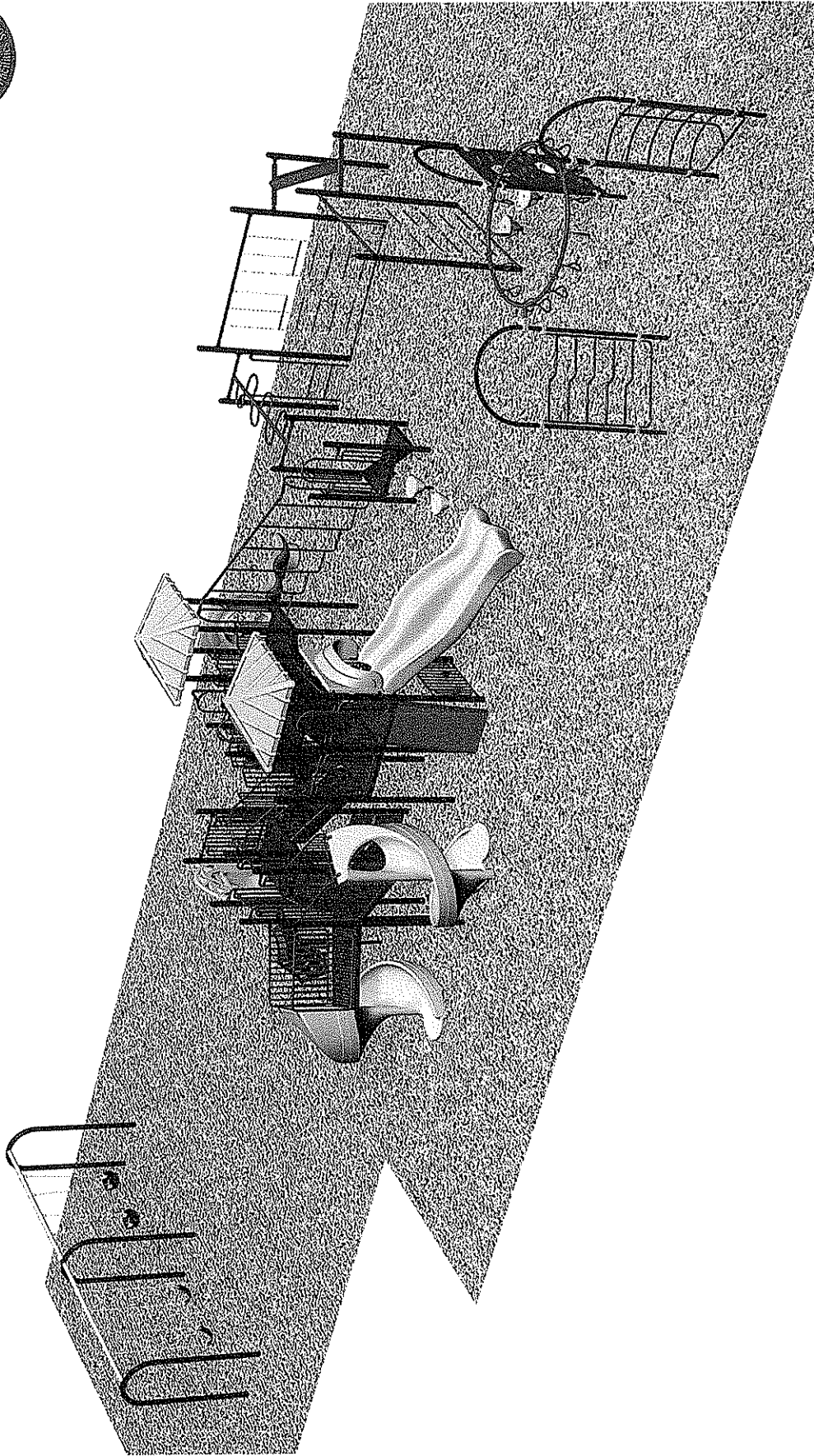

All colours shown here are approximate

Powder-Coated Metal Colours

HDPE Colours

Roto-Molded Plastic Colours



North Bend State Park - Recreation Area

Model No. B300002R0

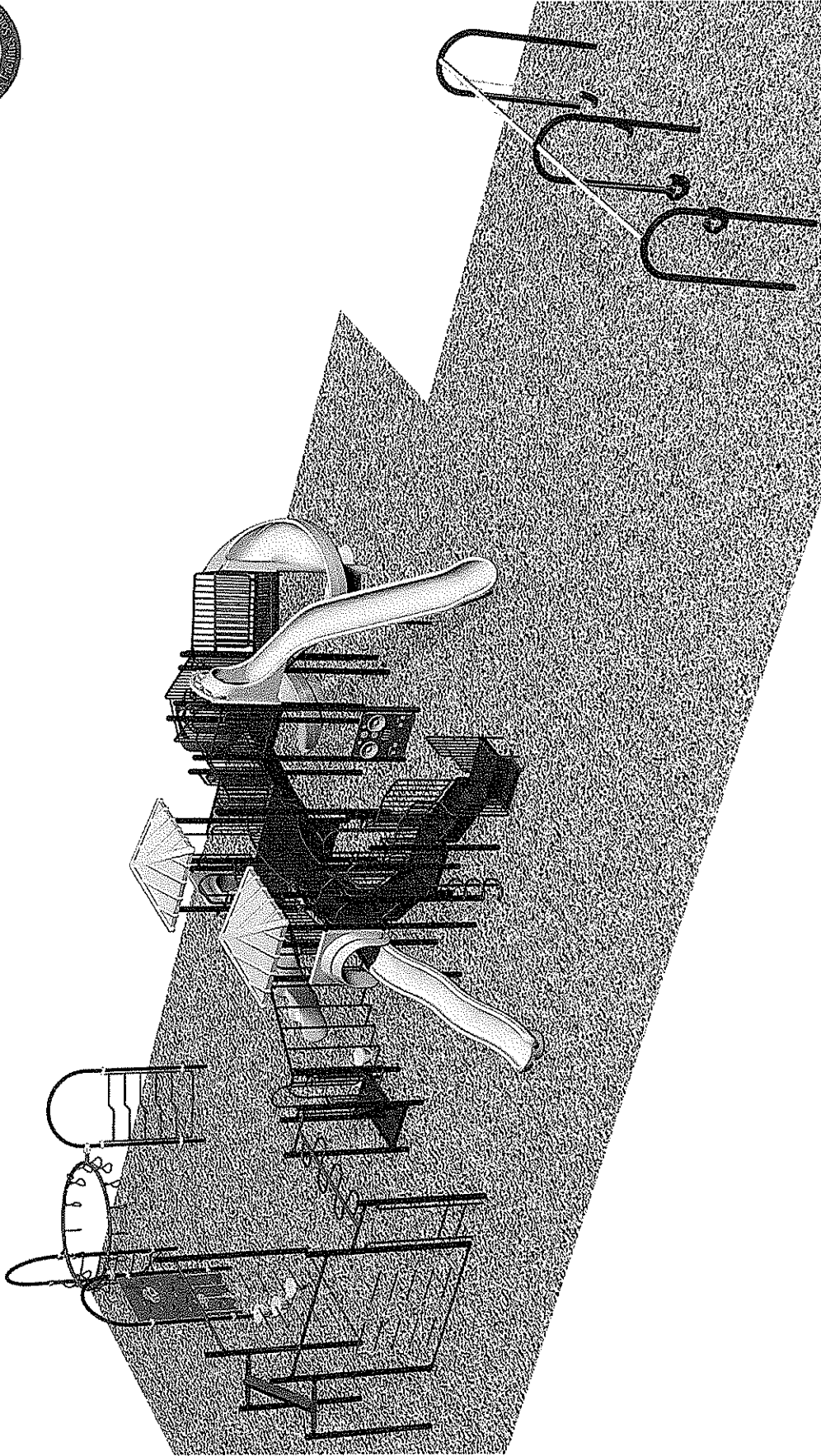

Model # B300002R0
Davis Athletics
North Bend State Park



WARNING
 Installation Over A Hard Surface Such As Concrete, Asphalt, Or Packed Earth From Falls in Serious Injury or Death

Best User Age: 5 to 12

Accessibility: Yes

Colour:

- Posts: Brown
- Accent: Green
- Roof Plastic: Tan
- 3/4 Plastic: Green/Tan
- Other:

Surfacing Type: Wood Chips

Border Area: 4491

Border Perimeter: 304

Installation Style:

Inground 36"

Footing Quantity: 0

Compliance:

CAN/CSA-Z614

Sales Rep: F.D.

Note: All border dimensions are inside border measurements. All dimensions are given in feet and inches unless otherwise specified. The locations of all telephone, hydro, cable, water, gas, and drainage lines must be clearly marked by the customer prior to the playground installation. All playgrounds must be installed with appropriate resilient surfacing and safety zones to meet the required guidelines of the latest CAN/CSA-Z614 (CAN) or ASTM F 1487 (USA) releases. The playground installation site must be properly prepared to Henderson Recreation specifications prior to installation. Henderson Recreation assumes the playground installation site has normal soil and digging conditions. Please notify us of any unusual soil conditions. Henderson Recreation Equipment Limited has a commitment to continuous product development and improvement and therefore reserves the right to improve, alter or discontinue products and specifications without notice.

***Attention:** No-encroachment zones that are adjacent to but outside of the safety zones must be free of any obstacles that would impede or block safe pedestrian traffic flow around the safety surface area. No-encroachment zones that are within the safety surface area must be free of all obstacles.

Drawn By: R.H.
 Date Drawn: April 6, 2009
 Revised By:
 Revision Date:
 Scale: See Key

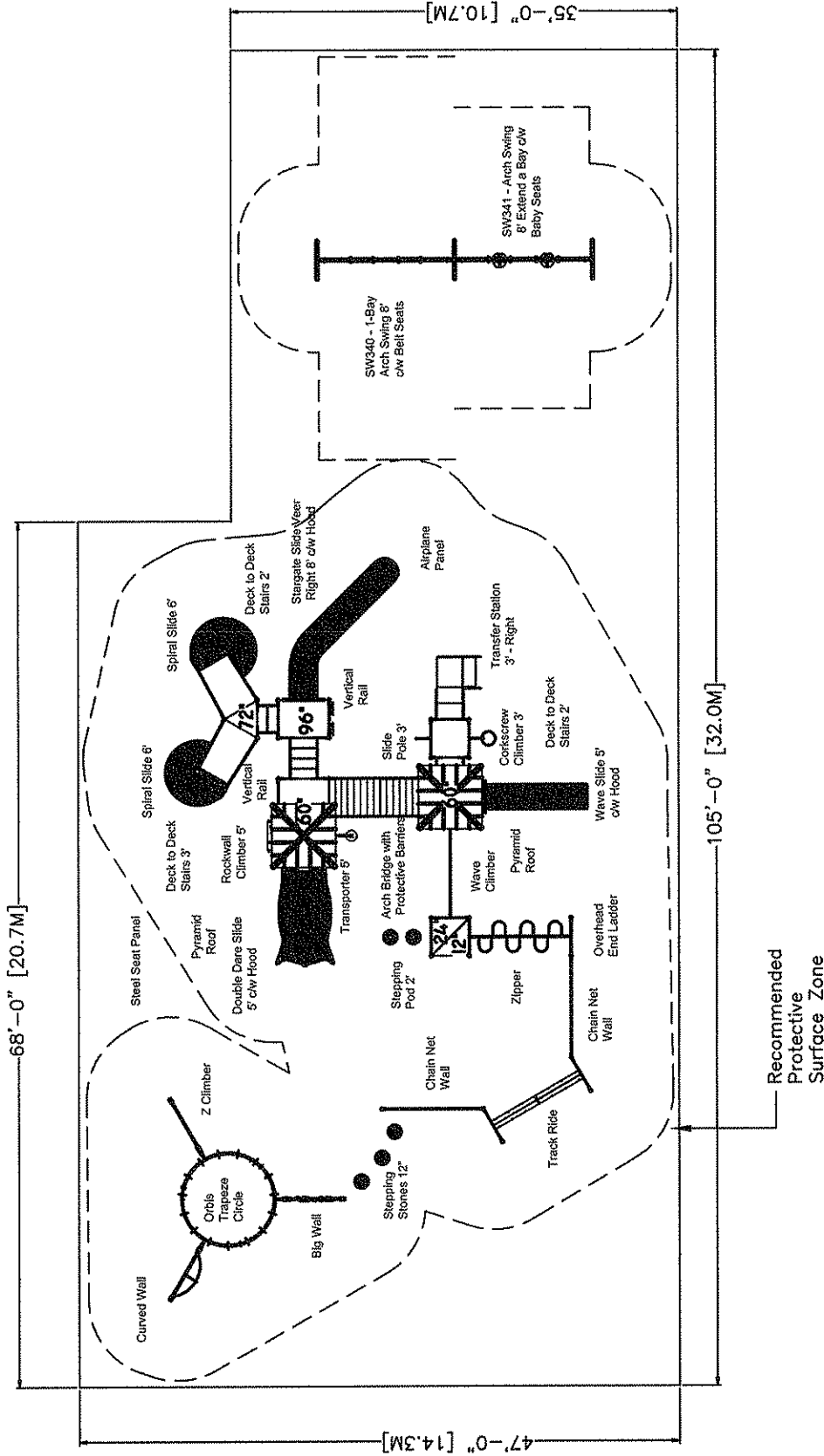

WARRANTY

Lifetime*

Limited warranty on steel posts, all stainless steel hardware, deck brackets and post caps against structural failure due to corrosion or deterioration caused by defects in materials and workmanship.

10 Year*

Limited warranty on Southern Yellow Pine pressure-treated wood components against structural failure due to insect infestation and fungal decay caused by defects in materials and workmanship.

10 Year*

Limited warranty on polyethylene components, sheet plastic and Plastisol-clad decks against structural failure due to corrosion or deterioration caused by defects in materials and workmanship.

One Year* General Warranty

Limited 1-Year Warranty on all other moving parts, swing seats, and any other materials not covered above. Henderson Recreation will repair or replace all parts of the product or equipment found to be defective free of charge. Warranty periods start at date of invoice.

* Items Not Covered in the above Warranties

Product or equipment that is not installed in conformity with the layout plan and/or installation instructions provided by Henderson Recreation; product or equipment that has not been maintained and inspected in accordance with Henderson Recreation's instructions; product or equipment that has been subjected to misuse, negligence or accident; product or equipment that has been subjected to addition, modification, alteration, repair, or part substitution by persons other than Henderson Recreation or Henderson Recreation's designees. Labour or damages resulting from vandalism, abnormal use, incorrect installation, and lack of routine maintenance are not covered by the above warranties. These warranties do not include any or all of the following cosmetic issues: scratches, dents, marring, fading of colours, discolouration, normal wear and tear and natural fading, and the weathering of wood, including but not limited to raised grain, splitting, checking, twisting, warping, shrinkage, swelling or any other physical property of the wood. The terms "rot" and "fungal decay," as used in this warranty mean attack by wood-destroying fungi that disintegrate the wood cell walls, but exclude surface mold and mildew fungi associated with the "weathering of wood." "Weathering" of wood is not decay, fungal decay, or rot of any type or definition. The above warranties are exclusive and in lieu of all other warranties, whether expressed or implied, including, but not limited to any warranty of merchantability or fitness for a particular purpose. Further, no representation, oral or written, of any representative of Henderson Recreation may be substituted for the afore described limited warranties. To the extent permitted by law, Henderson Recreation shall not be liable for, direct, indirect, special, incidental, or consequential damages which are expressly excluded from the above warranties.

20 Year*

Limited warranty on Southern Yellow Pine pressure-treated wood support posts against structural failure due to insect infestation and fungal decay caused by defects in materials and workmanship.

15 Year*

Limited warranty on steel rails, loops, and rungs against structural failure due to corrosion or deterioration caused by defects in materials and workmanship.

5 Year*

Limited Warranty on all Site Amenities, including all benches, tables, litter receptacles and bike racks, against structural failure due to corrosion or deterioration caused by defects in materials and workmanship.

Any freight costs associated with the warranty claim, any costs for dismantling the defective part in order to replace it, and any installation costs associated with the replacement part(s) are not considered part of this warranty and will not be paid by Henderson Recreation. This warranty excludes liability other than that expressly stated, including but not limited to any incidental or consequential damages.

Warranty Claims

To be valid, all warranty claims must be submitted in writing promptly following discovery of the defect(s) and within the specified warranty period. Henderson Recreation requires that all warranty claims be accompanied by a copy of the original invoice and photograph(s) clearly identifying the defect(s) in question.

Product Replacement

Henderson Recreation Equipment Limited has a commitment to continuous product development and improvement and therefore reserves the right to make approved substitutions in design or specifications.

Loss or Damage In Transit

Henderson Recreation cannot be held responsible for the loss or damage of products by common carriers. Please check the bill of lading carefully to ensure your product is in good order prior to signing it. After the product departs our plant(s), we are no longer responsible for any loss, damage, or shortage.

Maintenance

The demand for safety requires regular inspection of playground structures for signs of wear and tear. All necessary repairs should be completed promptly by a qualified repair person. For more information on the regulations concerning playground equipment, installation, maintenance, and protective surfacing, please refer to your local and national safety standards.

Henderson®

Call: 1-800-265-5462 Fax: (519) 426-1132

P.O. Box 68, 11 Gilbertson Drive, Simcoe, ON, Canada N5Y 4K8



WEBCOAT PRODUCTS
mfg. By VISIONS INNOVATED PRODUCTS INC.
P.O. Box 3160
McAlester, OK 74502

FACTORY WARRANTY

All WEBCOAT Thermo-Plastic, PVC coated products are warranted to the original purchaser of the products to be free of corrosion on seats and tops that results in bare metal exposure for a period of 5 YEARS after date of purchase, excluding any corrosion that may be the result of vandalism or intentional stripping of any of the coating.

WEBCOAT structural supports for tables and benches are warranted to the original purchase to be free of rust outs that would compromise structural integrity for a period of 5 YEARS after date purchase, surface rust or cosmetic paint deterioration is excluded.

Tables tops or seats or frames accompanied with copy of original invoice must be returned to the factory prepaid to validate this warranty. VISIONS INNOVATED PRODUCTS, INC. reserves the right to either repair any of the damage to the tops or seats or frames or to replace with new products and then return the product to the purchaser, freight collect.

WEBCOAT products have the highest level of ULTRA-VIOLET RETARDANTS in all coating compounds possible, however, VISIONS INNOVATED PRODUCTS, INC. cannot warrant fading or surface contamination, due to the extreme variations of exposure and definitions of fading.

All WEBCOAT park grilles are guaranteed against rust out or breakage to the original purchaser for a period of 5 YEARS after the date of purchase, excluding any damage that may be the result of vandalism or intentional destruction. Entire park grilles must be returned to the factory freight prepaid to validate this warranty. VISIONS INNOVATED PRODUCTS, INC. reserves the right to either repair the damage or to replace with new product and then return the product to the purchaser, freight collect.

WEBCOAT products have a one-year warranty on workmanship and materials excluding vandalism. Claims for defects must be accompanied by copies of the original invoice or invoice number.

VISIONS INNOVATED PRODUCTS, INC. PH: 918-426-5100 *** FX: 918-426-5924



B6WBRCs

**6' REGAL STYLE
BENCH WITH BACK
INGROUND MOUNT DESIGN**

WEBCOAT PRODUCTS
P.O. BOX 3160
McALESTER, OKLAHOMA 74501
1-800-505-5101
FAX: (918)426-5924
E-MAIL: WEBCOAT@WEBCOAT.COM

Please take the time to locate and identify each part. Assemble the units on a smooth flat surface. It is also helpful to lay the tops and seats on cardboard or a drop cloth to prevent scratching of the surface during assembly. All parts have been pre-cut and pre-drilled for ease of assembly. All holes are slotted to allow for easy assembly and for final levelling of tops and seats to frames. Fully assemble all parts without totally tightening nuts and bolts. After all assembled go back and retighten nuts to bolts. **DO NOT OVER TIGHTEN NUTS TO BOLTS.** Over tightened nuts can crack the plastisol coating. All the necessary quantities of parts required are listed in this assembly instructions.

DO NOT BEGIN ASSEMBLY UNTIL YOU HAVE READ THESE INSTRUCTIONS AND ARE FAMILIAR WITH THE PARTS.

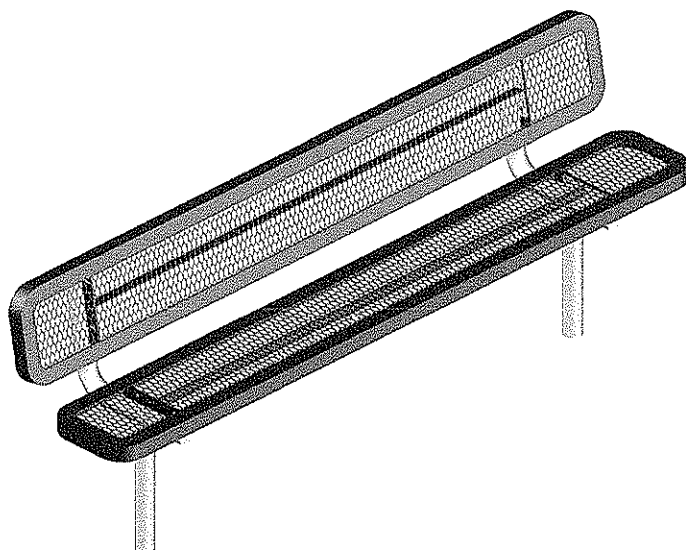

PARTS IDENTIFICATION

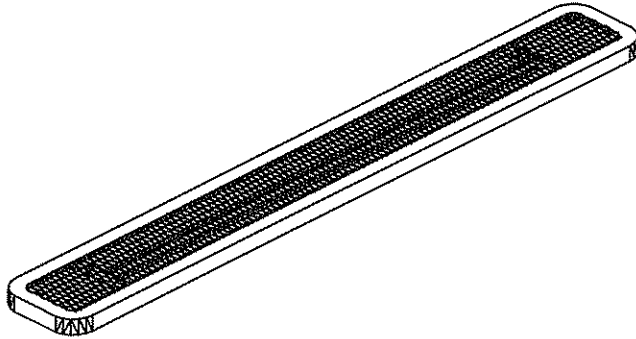

(A) 6' RC SEAT

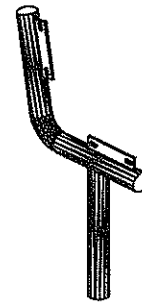

(B) BENCH FRAME

PARTS LIST

ITEM	PART#	DESCRIPTION	QTY.
A	S6RC	6' RC SEAT	2
B	FBWBI	BENCH FRAME W/BACK	2

ITEM	HARDWARE DESCRIPTION	QTY.
HW1	5/16" X 18 NYL LOCKNUTS	8
HW2	5/16" X 18GA CAP BOLTS	8
HW3	5/16" FLAT WASHERS	16
HW4	BOLT GUARDS	8

ASSEMBLY TOOLS REQUIRED
2- 1/2" WRENCHES

HARDWARE IDENTIFICATION



(HW1) 5/16" X 18
NYL LOCKNUTS



(HW2) 5/16" X 18
GAUGE CAP BOLTS



(HW3) 5/16"
FLAT WASHERS



(HW4) BOLT
GUARDS

ASSEMBLY PROCEDURES

STEP 1

MOUNT THE SEAT BY MEANS OF FOUR 5/16" X 1 1/2" HEXBOLTS, EIGHT 5/16" FLAT WASHERS AND FOUR 5/16" NYLOCK NUTS THROUGH THE SLOTTED HOLES ON THE SEATS AND THROUGH THE SLOTTED HOLES ON ANGLE IRON OF FRAME ENDS. Hand tighten only at this time.

STEP 2

MOUNT THE BACK BY MEANS OF FOUR 5/16" X 1 1/2" HEXBOLTS, EIGHT 5/16" FLAT WASHERS AND FOUR 5/16" NYLOCK NUTS THROUGH THE SLOTTED HOLES ON THE SEATS AND THROUGH THE SLOTTED HOLES ON ANGLE IRON OF FRAME ENDS.

STEP 3

FOLLOWING THE FOOTING DIAGRAM BELOW, DIG TWO INLINE HOLES APPROXIMATELY 24" DEEP BY 12" ROUND. THE DISTANCE BETWEEN HOLES 1 AND 2 IS 51 1/4" CENTER TO CENTER.

STEP 4

SET BENCH END FRAMES IN HOLES. MAKE SURE TOP OF SEATS ARE 18" ABOVE GROUND LEVEL AND ARE IN LINE. FILL WITH CONCRETE, LEVEL SEAT.

LET STAND 24 HOURS BEFORE COMPLETING ASSEMBLY INSTRUCTIONS.

STEP 5

TIGHTEN ALL NUTS ON ALL BOLTS AND PLACE THE BOLT GUARDS ON ALL NUTS. DO NOT OVER TIGHTEN THE NUTS AS THIS COULD CAUSE THE PLASTISOL COATING TO CRACK.



ANGLE BOLTS TO INSIDE OF BRACE, FACING EACH OTHER.

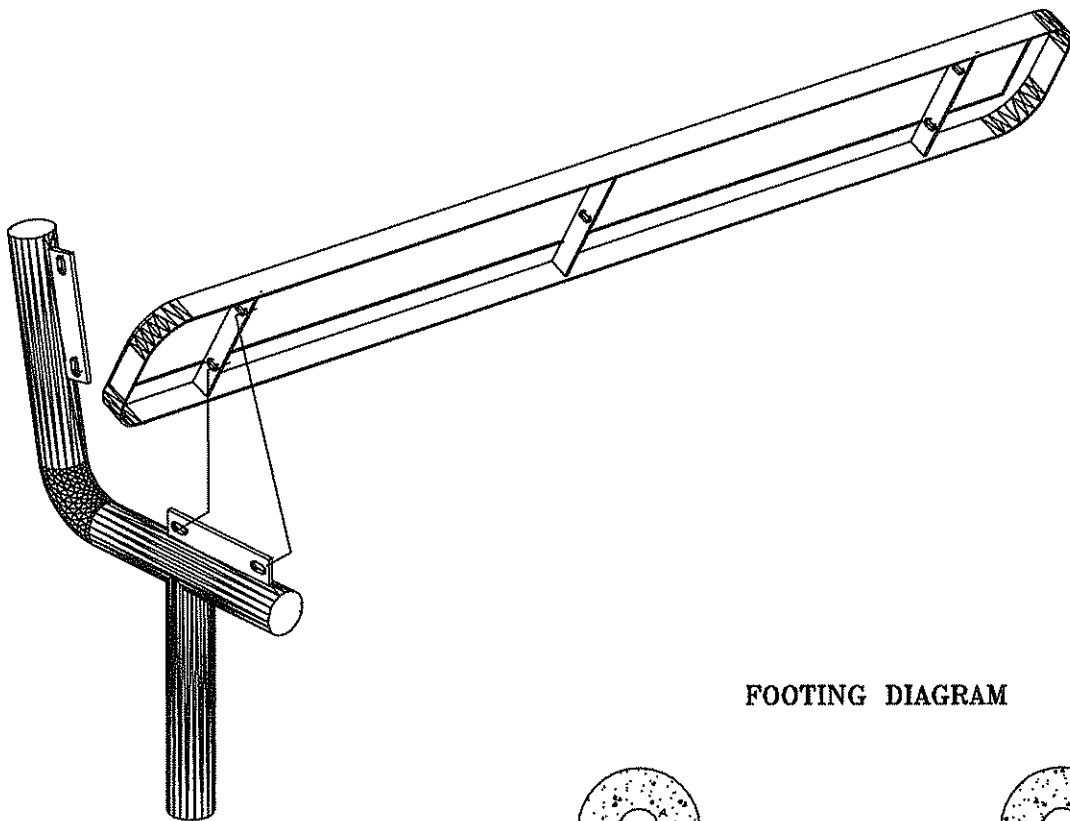

FOOTING DIAGRAM

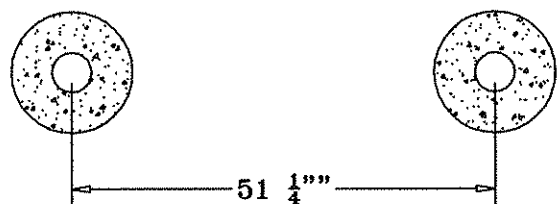

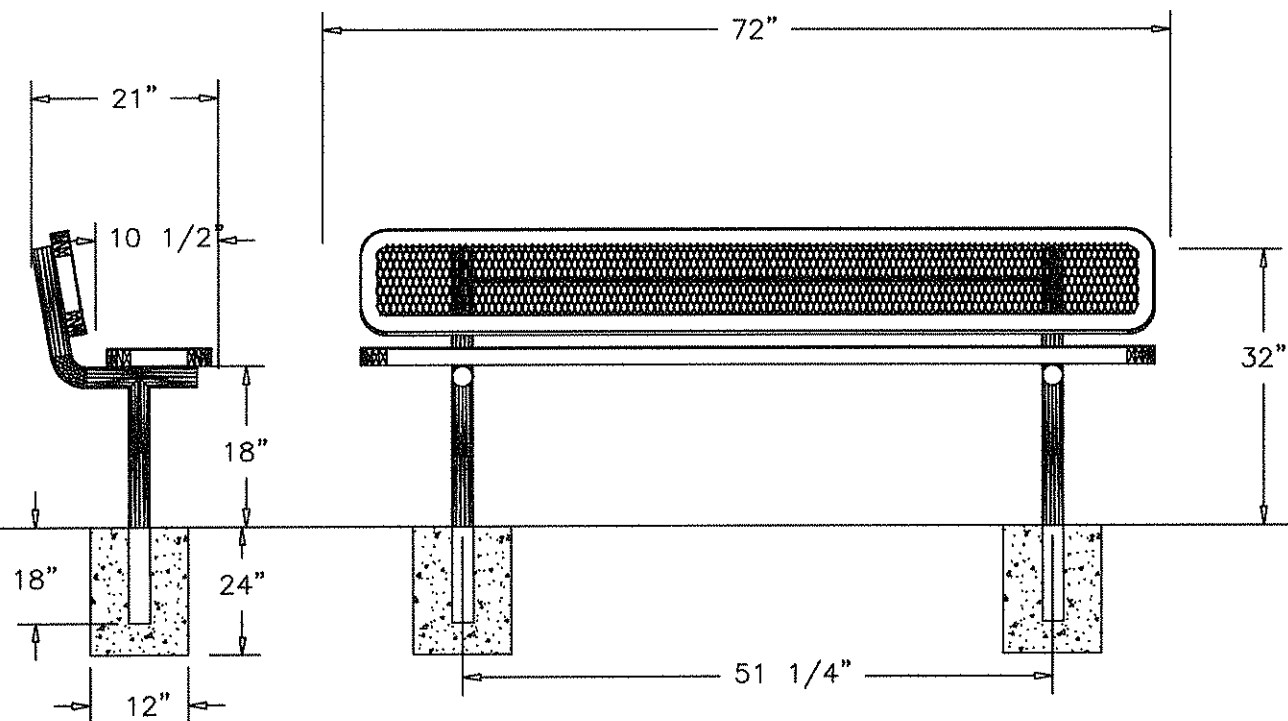

SPECIFICATIONS

6' POLY VINYL EXPANDED METAL BENCH WITH BACK. ALL CORNERS ARE ROUNDED. FRAME IS INGROUND MOUNT DESIGN.

COATED WITH A 1/8" TO 1/4" THICK PLASTISOL ULTRAVIOLET STABILIZED VINYL COATING FUSED AND BAKED TO A 90% GLOSS.

SEAT HEIGHT IS 18" APPROXIMATELY, BENCH HEIGHT IS 32" APPROXIMATELY. TOTAL OVERALL DIMENSIONS ARE 72" X 21" APPROXIMATELY.

SEATS ARE MADE FROM 3/4" #9 EXPANDED METAL INSIDE A 2" X 2" X 1/8" ANGLE IRON FRAME. ALL CENTER BRACES ARE MADE FROM 1/4" X 1 1/2" FLAT STEEL.

FRAMES ARE MADE OF 2 3/8" HEAVY GALVANIZED STEEL TUBING THAT IS GALVANIZED INSIDE AND OUT AND MEETS OR EXCEEDS YIELD AND TENSIL OF SCH. 40 PIPE. CONSTRUCTED SO AS TO PROHIBIT RAIN WATER FROM COLLECTING AT GROUND LEVEL. COATED WITH A BAKED ON POLYESTER POWDER COAT FINISH.

ALL HARDWARE IS NON-CORROSIVE.
WEIGHT FOR THE B6WBRCS IS 113 LBS.

MAINTENANCE

To maintain luster it is recommended to wash, rinse, and dry the units after prolonged use. Check for loose bolts and nuts and tighten as needed. Contact the factory for genuine Webcoat part replacements if needed.