



State of West Virginia
 Department of Administration
 Purchasing Division
 2019 Washington Street East
 Post Office Box 50130
 Charleston, WV 25305-0130

Request for Quotation

RFQ NUMBER
DJS010253

PAGE
1

ADDRESS CORRESPONDENCE TO ATTENTION OF
JOHN ABBOTT
304-558-2544

PROPERTY OF STATE OF WEST VIRGINIA

Long's Security Camera Systems LLC
 102 38th Street SE
 Charleston, WV 25304

PROPERTY OF STATE OF WEST VIRGINIA

DIVISION OF JUVENILE SERVICES
 SECOND FLOOR
 1200 QUARRIER STREET
 CHARLESTON, WV 25301
 304-558-6029

DATE PRINTED	TERMS OF SALE	SHIP VIA	FOB	FREIGHT TERMS
08/13/2008				

BID OPENING DATE: **08/28/2008** BID OPENING TIME **01:30PM**

LINE	QUANTITY	UOP	CAT NO	ITEM NUMBER	UNIT PRICE	AMOUNT
0001	1	LS		840-84		
<p>VIDEO SURVEILLANCE SYSTEMS</p> <p>OPEN-END CONTRACT TO PROVIDE VIDEO SURVEILLANCE EQUIPMENT TO THE WEST VIRGINIA DIVISION OF JUVENILE SERVICES, PER THE SPECIFICATIONS.</p> <p>EXHIBIT 4</p> <p>LOCAL GOVERNMENT BODIES: UNLESS THE VENDOR INDICATES IN THE BID HIS REFUSAL TO EXTEND THE PRICES, TERMS, AND CONDITIONS OF THE BID TO COUNTY, SCHOOL, MUNICIPAL AND OTHER LOCAL GOVERNMENT BODIES, THE BID SHALL EXTEND TO POLITICAL SUBDIVISIONS OF THE STATE OF WEST VIRGINIA. IF THE VENDOR DOES NOT WISH TO EXTEND THE PRICES, TERMS, AND CONDITIONS OF THE BID TO ALL POLITICAL SUBDIVISIONS OF THE STATE, THE VENDOR MUST CLEARLY INDICATE SUCH REFUSAL IN HIS BID. SUCH REFUSAL SHALL NOT PREJUDICE THE AWARD OF THIS CONTRACT IN ANY MANNER.</p> <p>REV. 3/88</p> <p>EXHIBIT 3</p> <p>LIFE OF CONTRACT: THIS CONTRACT BECOMES EFFECTIVE ON AND EXTENDS FOR A PERIOD OF ONE (1) YEAR OR UNTIL SUCH "REASONABLE TIME" THEREAFTER AS IS NECESSARY TO OBTAIN A NEW CONTRACT OR RENEW THE ORIGINAL CONTRACT. THE "REASONABLE TIME" PERIOD SHALL NOT EXCEED TWELVE (12) MONTHS. DURING THIS "REASONABLE</p>						

Novico Option #2

RECEIVED
 08 AUG 28 AM 11:14
 PURCHASING DIVISION
 STATE OF WV

SEE REVERSE SIDE FOR TERMS AND CONDITIONS

SIGNATURE *Alan E Long* TELEPHONE **304-925-0338** DATE **8-28-08**
 TITLE *Owner* FAX **20-388188-001** ADDRESS CHANGES TO BE NOTED ABOVE

WHEN RESPONDING TO RFQ, INSERT NAME AND ADDRESS IN SPACE ABOVE LABELED 'VENDOR'

**BID SUBMISSION WORKSHEET FOR
DJS 010253
ALL QUANTITIES ARE ESTIMATES ONLY**

ITEM
NO.

	ESTIMATED QUANTITY	ITEM	MODEL	UNIT PRICE	AMOUNT
1.	90	COLOR VARI-FOCAL MINI DOME CAMERA	COS21NI	138.75	12,487.50
2.	20	COLOR VARI-FOCAL DAY/NIGHT INFRARED MINI DOME CAMERA	CVSD2INL	227.55	4,551.00
3.	10	16 CAMERA 12VCD POWER SUPPLY	PS1216DCS-9	149.85	1,498.50
4.	5	8 CAMERA 12VCD POWER SUPPLY	PS1280DCS-9	124.32	621.60
5.	5	4 CAMERA 12VCD POWER SUPPLY	PS1240DCS-9	110.45	552.23
6.	5	4 CHANNEL NETWORKABLE TRIPLEX DVR WITH CD-R/W	EV4500N	660.45	3,302.25
7.	5	8 CHANNEL NETWORKABLE TRIPLEX DVR WITH CD-R/W	EV8500N	826.95	4,134.75
8.	10	16 CHANNEL NETWORKABLE TRIPLEX DVR WITH CD-R/W	EV16500N	1,193.25	11,932.50
9.	20	COLOR VARI-FOCAL INFRARED BULLET CAMERA	CBSD21NL	222.00	4,440.00

TOTAL \$ 43,520.33



State of West Virginia
 Department of Administration
 Purchasing Division
 2019 Washington Street East
 Post Office Box 50130
 Charleston, WV 25305-0130

Request for Quotation

RFQ NUMBER
DJS010253

PAGE
2

ADDRESS CORRESPONDENCE TO ATTENTION OF
JOHN ABBOTT
304-558-2544

RFQ COPY
 TYPE NAME/ADDRESS HERE

VENDOR

SHIP TO

DIVISION OF JUVENILE SERVICES
 SECOND FLOOR
 1200 QUARRIER STREET
 CHARLESTON, WV
 25301 304-558-6029

DATE PRINTED 08/13/2008	TERMS OF SALE	SHIP VIA	FOB	FREIGHT TERMS
BID OPENING DATE: 08/28/2008		BID OPENING TIME 01:30PM		

LINE	QUANTITY	UOP	CAT NO	ITEM NUMBER	UNIT PRICE	AMOUNT
<p>TIME" THE VENDOR MAY TERMINATE THIS CONTRACT FOR ANY REASON UPON GIVING THE DIRECTOR OF PURCHASING 30 DAYS WRITTEN NOTICE.</p> <p>UNLESS SPECIFIC PROVISIONS ARE STIPULATED ELSEWHERE IN THIS CONTRACT DOCUMENT, THE TERMS, CONDITIONS AND PRICING SET HEREIN ARE FIRM FOR THE LIFE OF THE CONTRACT.</p> <p>RENEWAL: THIS CONTRACT MAY BE RENEWED UPON THE MUTUAL WRITTEN CONSENT OF THE SPENDING UNIT AND VENDOR, SUBMITTED TO THE DIRECTOR OF PURCHASING THIRTY (30) DAYS PRIOR TO THE EXPIRATION DATE. SUCH RENEWAL SHALL BE IN ACCORDANCE WITH THE TERMS AND CONDITIONS OF THE ORIGINAL CONTRACT AND SHALL BE LIMITED TO TWO (2) ONE (1) YEAR PERIODS.</p> <p>CANCELLATION: THE DIRECTOR OF PURCHASING RESERVES THE RIGHT TO CANCEL THIS CONTRACT IMMEDIATELY UPON WRITTEN NOTICE TO THE VENDOR IF THE COMMODITIES AND/OR SERVICES SUPPLIED ARE OF AN INFERIOR QUALITY OR DO NOT CONFORM TO THE SPECIFICATIONS OF THE BID AND CONTRACT HEREIN.</p> <p>OPEN MARKET CLAUSE: THE DIRECTOR OF PURCHASING MAY AUTHORIZE A SPENDING UNIT TO PURCHASE ON THE OPEN MARKET, WITHOUT THE FILING OF A REQUISITION OR COST ESTIMATE, ITEMS SPECIFIED ON THIS CONTRACT FOR IMMEDIATE DELIVERY IN EMERGENCIES DUE TO UNFORESEEN CAUSES (INCLUDING BUT NOT LIMITED TO DELAYS IN TRANSPORTATION OR AN UNANTICIPATED INCREASE IN THE VOLUME OF WORK.)</p> <p>QUANTITIES: QUANTITIES LISTED IN THE REQUISITION ARE APPROXIMATIONS ONLY, BASED ON ESTIMATES SUPPLIED BY THE STATE SPENDING UNIT. IT IS UNDERSTOOD AND AGREED THAT THE CONTRACT SHALL COVER THE QUANTITIES ACTUALLY</p>						

SEE REVERSE SIDE FOR TERMS AND CONDITIONS

SIGNATURE _____ TELEPHONE _____ DATE _____

TITLE _____ FEIN _____ ADDRESS CHANGES TO BE NOTED ABOVE

WHEN RESPONDING TO RFQ, INSERT NAME AND ADDRESS IN SPACE ABOVE LABELED 'VENDOR'



State of West Virginia
 Department of Administration
 Purchasing Division
 2019 Washington Street East
 Post Office Box 50130
 Charleston, WV 25305-0130

Request for Quotation

RFQ NUMBER
DJS010253

PAGE
3

ADDRESS CORRESPONDENCE TO ATTENTION OF
JOHN ABBOTT
304-558-2544

RFQ COPY

TYPE NAME/ADDRESS HERE

SHIP TO

DIVISION OF JUVENILE SERVICES

SECOND FLOOR
1200 QUARRIER STREET
CHARLESTON, WV
25301 **304-558-6029**

DATE PRINTED	TERMS OF SALE	SHIP VIA	FOB	FREIGHT TERMS
08/13/2008				

BID OPENING DATE: **08/28/2008** BID OPENING TIME **01:30PM**

LINE	QUANTITY	UOP	CAT NO	ITEM NUMBER	UNIT PRICE	AMOUNT
<p>ORDERED FOR DELIVERY DURING THE TERM OF THE CONTRACT, WHETHER MORE OR LESS THAN THE QUANTITIES SHOWN.</p> <p>ORDERING PROCEDURE: SPENDING UNIT(S) SHALL ISSUE A WRITTEN STATE CONTRACT ORDER (FORM NUMBER WV-39) TO THE VENDOR FOR COMMODITIES COVERED BY THIS CONTRACT. THE ORIGINAL COPY OF THE WV-39 SHALL BE MAILED TO THE VENDOR AS AUTHORIZATION FOR SHIPMENT, A SECOND COPY MAILED TO THE PURCHASING DIVISION, AND A THIRD COPY RETAINED BY THE SPENDING UNIT.</p> <p>BANKRUPTCY: IN THE EVENT THE VENDOR/CONTRACTOR FILES FOR BANKRUPTCY PROTECTION, THIS CONTRACT IS AUTOMATICALLY NULL AND VOID, AND IS TERMINATED WITHOUT FURTHER ORDER.</p> <p>THE TERMS AND CONDITIONS CONTAINED IN THIS CONTRACT SHALL SUPERSEDE ANY AND ALL SUBSEQUENT TERMS AND CONDITIONS WHICH MAY APPEAR ON ANY ATTACHED PRINTED DOCUMENTS SUCH AS PRICE LISTS, ORDER FORMS, SALES AGREEMENTS OR MAINTENANCE AGREEMENTS, INCLUDING ANY ELECTRONIC MEDIUM SUCH AS CD-ROM.</p> <p>REV. 04/11/2001</p> <p>VENDOR PREFERENCE CERTIFICATE</p> <p>CERTIFICATION AND APPLICATION* IS HEREBY MADE FOR PREFERENCE IN ACCORDANCE WITH WEST VIRGINIA CODE, 5A-3-37 (DOES NOT APPLY TO CONSTRUCTION CONTRACTS).</p> <p>A. APPLICATION IS MADE FOR 2.5% PREFERENCE FOR THE REASON CHECKED:</p> <p><input checked="" type="checkbox"/> BIDDER IS AN INDIVIDUAL RESIDENT VENDOR AND HAS RESIDED CONTINUOUSLY IN WEST VIRGINIA FOR FOUR</p>						

SEE REVERSE SIDE FOR TERMS AND CONDITIONS

SIGNATURE	TELEPHONE	DATE
TITLE	FEIN	ADDRESS CHANGES TO BE NOTED ABOVE

WHEN RESPONDING TO RFQ, INSERT NAME AND ADDRESS IN SPACE ABOVE LABELED 'VENDOR'



State of West Virginia
 Department of Administration
 Purchasing Division
 2019 Washington Street East
 Post Office Box 50130
 Charleston, WV 25305-0130

Request for Quotation

RFQ NUMBER
DJS010253

PAGE
4

ADDRESS CORRESPONDENCE TO ATTENTION OF
JOHN ABBOTT
304-558-2544

RFQ COPY
 TYPE NAME/ADDRESS HERE

V
E
N
D
O
R

S
H
I
P
T
O

DIVISION OF JUVENILE SERVICES
 SECOND FLOOR
 1200 QUARRIER STREET
 CHARLESTON, WV
 25301 304-558-6029

DATE PRINTED	TERMS OF SALE	SHIP VIA	FOB	FREIGHT TERMS
08/13/2008				
BID OPENING DATE: 08/28/2008			BID OPENING TIME 01:30PM	

LINE	QUANTITY	UOP	CAT NO	ITEM NUMBER	UNIT PRICE	AMOUNT
<p>(4) YEARS IMMEDIATELY PRECEDING THE DATE OF THIS CERTIFICATION; OR</p> <p>() BIDDER IS A PARTNERSHIP, ASSOCIATION OR CORPORATION RESIDENT VENDOR AND HAS MAINTAINED ITS HEAD-QUARTERS OR PRINCIPAL PLACE OF BUSINESS CONTINUOUSLY IN WEST VIRGINIA FOR FOUR (4) YEARS IMMEDIATELY PRECEDING THE DATE OF THIS CERTIFICATION; OR 80% OF THE OWNERSHIP INTEREST OF BIDDER IS HELD BY ANOTHER INDIVIDUAL, PARTNERSHIP, ASSOCIATION OR CORPORATION RESIDENT VENDOR WHO HAS MAINTAINED ITS HEADQUARTERS OR PRINCIPAL PLACE OF BUSINESS CONTINUOUSLY IN WEST VIRGINIA FOR FOUR (4) YEARS IMMEDIATELY PRECEDING THE DATE OF THIS CERTIFICATION; OR</p> <p>() BIDDER IS A CORPORATION NONRESIDENT VENDOR WHICH HAS AN AFFILIATE OR SUBSIDIARY WHICH EMPLOYS A MINIMUM OF ONE HUNDRED STATE RESIDENTS AND WHICH HAS MAINTAINED ITS HEADQUARTERS OR PRINCIPAL PLACE OF BUSINESS WITHIN WEST VIRGINIA CONTINUOUSLY FOR THE FOUR (4) YEARS IMMEDIATELY PRECEDING THE DATE OF THIS CERTIFICATION.</p> <p>B. APPLICATION IS MADE FOR 2.5% PREFERENCE FOR THE REASON CHECKED:</p> <p>* BIDDER IS A RESIDENT VENDOR WHO CERTIFIES THAT, DURING THE LIFE OF THE CONTRACT, ON AVERAGE AT LEAST 75% OF THE EMPLOYEES WORKING ON THE PROJECT BEING BID ARE RESIDENTS OF WEST VIRGINIA WHO HAVE RESIDED IN THE STATE CONTINUOUSLY FOR THE TWO YEARS IMMEDIATELY PRECEDING SUBMISSION OF THIS BID;</p> <p>OR</p> <p>() BIDDER IS A NONRESIDENT VENDOR EMPLOYING A MINIMUM OF ONE HUNDRED STATE RESIDENTS OR IS A NONRESIDENT VENDOR WITH AN AFFILIATE OR SUBSIDIARY</p>						

SEE REVERSE SIDE FOR TERMS AND CONDITIONS

SIGNATURE _____ TELEPHONE _____ DATE _____

TITLE _____ FEIN _____ ADDRESS CHANGES TO BE NOTED ABOVE

WHEN RESPONDING TO RFQ, INSERT NAME AND ADDRESS IN SPACE ABOVE LABELED 'VENDOR'



State of West Virginia
 Department of Administration
 Purchasing Division
 2019 Washington Street East
 Post Office Box 50130
 Charleston, WV 25305-0130

Request for Quotation

RFQ NUMBER
DJS010253

PAGE
5

ADDRESS CORRESPONDENCE TO ATTENTION OF
JOHN ABBOTT
304-558-2544

RFQ COPY
 TYPE NAME/ADDRESS HERE

RFQ COPY

RFQ COPY

DIVISION OF JUVENILE SERVICES
 SECOND FLOOR
 1200 QUARRIER STREET
 CHARLESTON, WV
 25301 304-558-6029

DATE PRINTED	TERMS OF SALE	SHIP VIA	F.O.B.	FREIGHT TERMS
08/13/2008				

BID OPENING DATE: **08/28/2008** BID OPENING TIME **01:30PM**

LINE	QUANTITY	UQP	CAT. NO.	ITEM NUMBER	UNIT PRICE	AMOUNT
<p>WHICH MAINTAINS ITS HEADQUARTERS OR PRINCIPAL PLACE OF BUSINESS WITHIN WEST VIRGINIA EMPLOYING A MINIMUM OF ONE HUNDRED STATE RESIDENTS WHO CERTIFIES THAT, DURING THE LIFE OF THE CONTRACT, ON AVERAGE AT LEAST 75% OF THE EMPLOYEES OR BIDDERS' AFFILIATE'S OR SUBSIDIARY'S EMPLOYEES ARE RESIDENTS OF WEST VIRGINIA WHO HAVE RESIDED IN THE STATE CONTINUOUSLY FOR THE TWO YEARS IMMEDIATELY PRECEDING SUBMISSION OF THIS BID.</p> <p>BIDDER UNDERSTANDS IF THE SECRETARY OF TAX & REVENUE DETERMINES THAT A BIDDER RECEIVING PREFERENCE HAS FAILED TO CONTINUE TO MEET THE REQUIREMENTS FOR SUCH PREFERENCE, THE SECRETARY MAY ORDER THE DIRECTOR OF PURCHASING TO: (A) RESCIND THE CONTRACT OR PURCHASE ORDER ISSUED; OR (B) ASSESS A PENALTY AGAINST SUCH BIDDER IN AN AMOUNT NOT TO EXCEED 5% OF THE BID AMOUNT AND THAT SUCH PENALTY WILL BE PAID TO THE CONTRACTING AGENCY OR DEDUCTED FROM ANY UNPAID BALANCE ON THE CONTRACT OR PURCHASE ORDER.</p> <p>BY SUBMISSION OF THIS CERTIFICATE, BIDDER AGREES TO DISCLOSE ANY REASONABLY REQUESTED INFORMATION TO THE PURCHASING DIVISION AND AUTHORIZES THE DEPARTMENT OF TAX AND REVENUE TO DISCLOSE TO THE DIRECTOR OF PURCHASING APPROPRIATE INFORMATION VERIFYING THAT BIDDER HAS PAID THE REQUIRED BUSINESS TAXES, PROVIDED THAT SUCH INFORMATION DOES NOT CONTAIN THE AMOUNTS OF TAXES PAID NOR ANY OTHER INFORMATION DEEMED BY THE TAX COMMISSIONER TO BE CONFIDENTIAL.</p> <p>UNDER PENALTY OF LAW FOR FALSE SWEARING (WEST VIRGINIA CODE 61-5-3), BIDDER HEREBY CERTIFIES THAT THIS CERTIFICATE IS TRUE AND ACCURATE IN ALL RESPECTS; AND THAT IF A CONTRACT IS ISSUED TO BIDDER AND IF ANYTHING CONTAINED WITHIN THIS CERTIFICATE CHANGES DURING THE TERM OF THE CONTRACT, BIDDER WILL NOTIFY THE</p>						

SEE REVERSE SIDE FOR TERMS AND CONDITIONS

SIGNATURE	TELEPHONE	DATE
TITLE	FEIN	ADDRESS CHANGES TO BE NOTED ABOVE

WHEN RESPONDING TO RFQ, INSERT NAME AND ADDRESS IN SPACE ABOVE LABELED 'VENDOR'



State of West Virginia
 Department of Administration
 Purchasing Division
 2019 Washington Street East
 Post Office Box 50130
 Charleston, WV 25305-0130

Request for Quotation

RFQ NUMBER
DJS010253

PAGE
6

ADDRESS CORRESPONDENCE TO ATTENTION OF
JOHN ABBOTT
304-558-2544

PROPERTY

RFQ COPY
 TYPE NAME/ADDRESS HERE

PROPERTY

DIVISION OF JUVENILE SERVICES
 SECOND FLOOR
 1200 QUARRIER STREET
 CHARLESTON, WV
 25301 304-558-6029

DATE PRINTED	TERMS OF SALE	SHIP VIA	F.O.B.	FREIGHT TERMS
08/13/2008				

BID OPENING DATE: **08/28/2008** BID OPENING TIME **01:30PM**

LINE	QUANTITY	UOP	CAT NO.	ITEM NUMBER	UNIT PRICE	AMOUNT
PURCHASING DIVISION IN WRITING IMMEDIATELY.						
BIDDER: <u>Longs' Security Camera Systems LLC</u>						
DATE: <u>08-28-08</u>						
SIGNED: <u>Alvin E. Long</u>						
TITLE: <u>Owner</u>						
* CHECK ANY COMBINATION OF PREFERENCE CONSIDERATION(S) IN EITHER "A" OR "B", OR BOTH "A" AND "B" WHICH YOU ARE ENTITLED TO RECEIVE. YOU MAY REQUEST UP TO THE MAXIMUM 5% PREFERENCE FOR BOTH "A" AND "B". (REV. 12/00)						
NOTICE						
A SIGNED BID MUST BE SUBMITTED TO:						
DEPARTMENT OF ADMINISTRATION PURCHASING DIVISION BUILDING 15 2019 WASHINGTON STREET, EAST CHARLESTON, WV 25305-0130						
THE BID SHOULD CONTAIN THIS INFORMATION ON THE FACE OF THE ENVELOPE OR THE BID MAY NOT BE CONSIDERED:						

SEE REVERSE SIDE FOR TERMS AND CONDITIONS

SIGNATURE	TELEPHONE	DATE
TITLE	FEIN	ADDRESS CHANGES TO BE NOTED ABOVE

WHEN RESPONDING TO RFQ, INSERT NAME AND ADDRESS IN SPACE ABOVE LABELED 'VENDOR'

STATE OF WEST VIRGINIA
Purchasing Division

PURCHASING AFFIDAVIT

VENDOR OWING A DEBT TO THE STATE:

West Virginia Code §5A-3-10a provides that: No contract or renewal of any contract may be awarded by the state or any of its political subdivisions to any vendor or prospective vendor when the vendor or prospective vendor or a related party to the vendor or prospective vendor is a debtor and the debt owed is an amount greater than one thousand dollars in the aggregate.

PUBLIC IMPROVEMENT CONTRACTS & DRUG-FREE WORKPLACE ACT:

West Virginia Code §21-1D-5 provides that: Any solicitation for a public improvement construction contract shall require each vendor that submits a bid for the work to submit at the same time an affidavit that the vendor has a written plan for a drug-free workplace policy in compliance with Article 1D, Chapter 21 of the West Virginia Code. A public improvement construction contract may not be awarded to a vendor who does not have a written plan for a drug-free workplace policy in compliance with Article 1D, Chapter 21 of the West Virginia Code and who has not submitted that plan to the appropriate contracting authority in timely fashion. For a vendor who is a subcontractor, compliance with Section 5, Article 1D, Chapter 21 of the West Virginia Code may take place before their work on the public improvement is begun.

ANTITRUST:

In submitting a bid to any agency for the state of West Virginia, the bidder offers and agrees that if the bid is accepted the bidder will convey, sell, assign or transfer to the state of West Virginia all rights, title and interest in and to all causes of action it may now or hereafter acquire under the antitrust laws of the United States and the state of West Virginia for price fixing and/or unreasonable restraints of trade relating to the particular commodities or services purchased or acquired by the state of West Virginia. Such assignment shall be made and become effective at the time the purchasing agency tenders the initial payment to the bidder.

I certify that this bid is made without prior understanding, agreement, or connection with any corporation, firm, limited liability company, partnership or person or entity submitting a bid for the same materials, supplies, equipment or services and is in all respects fair and without collusion or fraud. I further certify that I am authorized to sign the certification on behalf of the bidder or this bid.

LICENSING:

Vendors must be licensed and in good standing in accordance with any and all state and local laws and requirements by any state or local agency of West Virginia, including, but not limited to, the West Virginia Secretary of State's Office, the West Virginia Tax Department, West Virginia Insurance Commission, or any other state agencies or political subdivision. Furthermore, the vendor must provide all necessary releases to obtain information to enable the Director or spending unit to verify that the vendor is licensed and in good standing with the above entities.

CONFIDENTIALITY:

The vendor agrees that he or she will not disclose to anyone, directly or indirectly, any such personally identifiable information or other confidential information gained from the agency, unless the individual who is the subject of the information consents to the disclosure in writing or the disclosure is made pursuant to the agency's policies, procedures and rules. Vendors should visit www.state.wv.us/admin/purchase/privacy for the Notice of Agency Confidentiality Policies.

Under penalty of law for false swearing (West Virginia Code §61-5-3), it is hereby certified that the vendor acknowledges the information in this said affidavit and is in compliance with the requirements as stated.

Vendor's Name: Longs Security Camera Systems LLC
Authorized Signature: Alan E. Long Date: 8-28-08

CD-S21N/P



Flush Mount

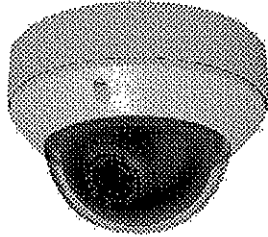

Flush Housing with Surface Mount

Key Features

- 1/3" CCD Sensor
- 550 TV Lines
- 2.8~10mm, DC Auto Iris
- 0.1 Lux(Color), 0.002 Lux(DSS On)
- Separate Camera Control Board
 - OSD Menu
 - Service Monitor Output
- 12VDC/24VAC Dual Voltage

Construction

- 4" Polycarbonate Bubble
- 3-Axis Gimbal
- Flush Mount Housing w/ Surface Mount Plate in a single package
- Aluminum Mounting Accessories(Optional)
- Ivory or Black Plastic Housing(Optional)
- Compact Size

Dome Inside View

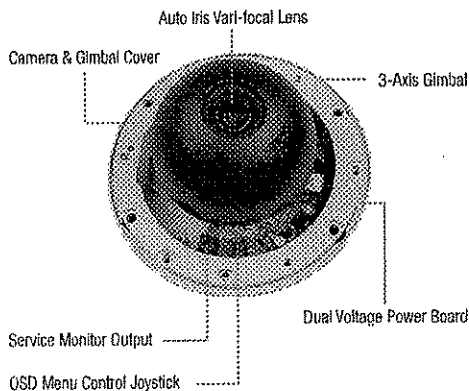

Technical Specifications

NTSC = (N), PAL = (P)

Item	CD-S21N/P
Video Format	NTSC / PAL
Image Sensor	1/3" CCD
Sync System	Internal / Line Lock(Optional)
Effective Pixels	768(H) x 494(V)(N) / 752(H) x 582(V)(P)
Scanning system	525 Lines, 2:1 Interlaced(N), 625 Lines, 2:1 Interlaced(P)
Electronic Shutter	1/60 ~ 1/120,000 sec.(N), 1/50 ~ 1/120,000 sec.(P)
Main Video Output	1.0 Vp-p Composite, 75 ohm
Service Monitor Output	1.0 Vp-p Composite, 75 ohm
Horizontal Resolution	550 TV Lines
Min. Illumination	0.1 Lux(Color), 0.002 Lux(DSS On)
S/N Ratio	More than 50dB(AGC Off)
Lens (DC Auto Iris)	Vari-focal: 2.8-10mm
Angle of View	132.1°(W) ~ 36°(T)
Camera Control & Setup	OSD Menu
Operating Temperature	-5°C ~ +45°C
Operating Humidity	Within 90% RH
Power Consumption	500mA
Input Voltage	12VDC/24VAC Dual Voltage

* Must use specified and regulated 12VDC/24VAC power supply.

Available Models

CD-S21N/P-I	Ivory Housing
CD-S21N/P-B	Black Housing

Accessories

CA-SMG3D	Service Monitor Cable
CV-WM	Indoor Wall Mount
CA-PM	Pedestal Mount
CA-JB	Junction Box

Dimensions (UNIT: mm)

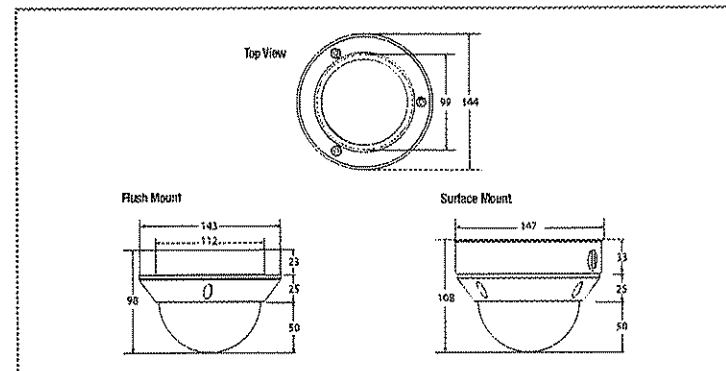

EASYVIEW

CV-SD21N/P-L



Flush Mount w/ IR LEDs Module

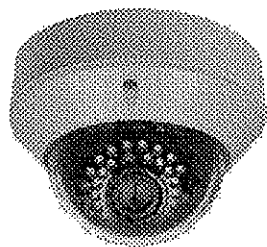

Flush Housing with Surface Mount

Key Features

- 1/3" CCD Sensor
- 550 TV Lines
- Day/Night function with ICR
- 2.8-10mm, DC Auto Iris
- 0.1 Lux(Color), 0.01 Lux(B/W), 0.002 Lux(DSS On)
- 36 IR LEDs
- Separate Camera Control Board
 - OSD Menu
 - Service Monitor Output
- 12VDC/24VAC Dual Voltage

Construction

- 4" Polycarbonate Bubble
- 3-Axis Gimbal
- Flush Mount Housing w/ Surface Mount Plate in a single package
- Impact Resistant Dome w/ Aluminum Housing
- Weatherproof - IP66
- Aluminum Mounting Accessories(Optional)
- Fan & Heater(Optional)
- Compact Size

Dome Inside View

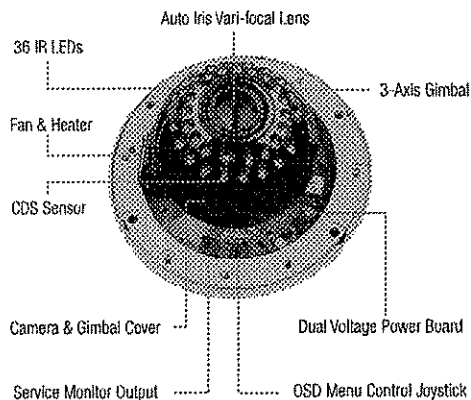

Technical Specifications

Item	CV-SD21N/P-L
Video Format	NTSC / PAL
Image Sensor	1/3" CCD
Sync System	Internal / Line Lock(Optional)
Effective Pixels	768(H) x 494(V)(N) / 752(H) x 582(V)(P)
Scanning System	525 Lines: 2:1 Interlaced(N), 625 Lines: 2:1 Interlaced(P)
Electronic Shutter	1/60 ~ 1/120,000 sec.(N), 1/50 ~ 1/120,000 sec.(P)
Main Video Output	1.0 Vp-p Composite, 75 ohm
Service Monitor Output	1.0 Vp-p Composite, 75 ohm
Horizontal Resolution	550 TV Lines
Min. Illumination	0.1 Lux(Color), 0.01 Lux(B/W), 0.002 Lux(DSS On)
S/N Ratio	More than 50dB(AGC Off)
Lens (DC Auto Iris)	Vari-focal: 2.8-10mm
Angle of View	132.1°(W) ~ 36°(T)
Day/Night Function	ICR
36 IR LEDs	LED Distance: up to 100ft.
LED Illumination Angle	60°
Camera Control & Setup	OSD Menu
Operating Temperature	-5°C ~ +45°C(Normal), -40°C ~ +45°C(w/ Fan & Heater)
Operating Humidity	Within 90% RH
Weatherproof	IP66(Only applies to Vandalproof Housing)
Power Consumption	500mA (Camera) 1 Amp (w/ LED On) Fan & Heater - 20VA(24VAC Only)
Input Voltage	12VDC/24VAC Dual Voltage

* Must use specified and regulated 12VDC/24VAC power supply.

Accessories

CV-FH	Fan & Heater
CA-SMC30	Service Monitor Cable
CV-WM	Indoor Wall Mount
CA-DM	Outdoor Wall Mount
CA-PM	Pedestal Mount
CA-JB	Junction Box

Dimensions (UNIT: mm)

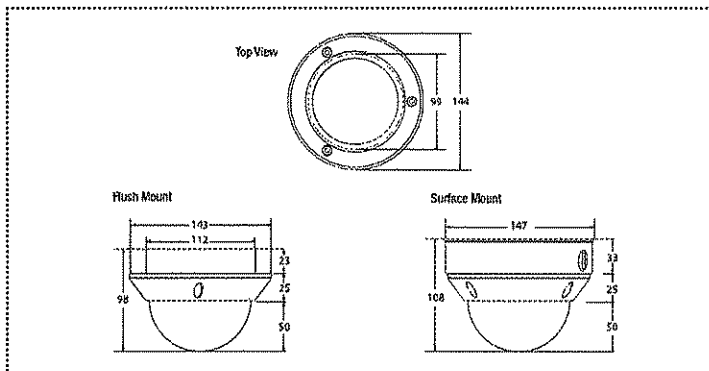

EASYVIEW



PS-1200DCS-9 Series

HIGH POWERED DC CCTV POWER SUPPLIES

PS-1240DCS-9: 4 OUTPUTS

PS-1280DCS-9: 8 OUTPUTS

PS-1216DCS-9: 16 OUTPUTS

**9 AMPS POWER AVAILABLE
AT 12V DC**

**IDEAL FOR CAMERAS WITH
INFRARED ILLUMINATORS**

**SELF-RESETTING
SMARTFUSE PROTECTION**

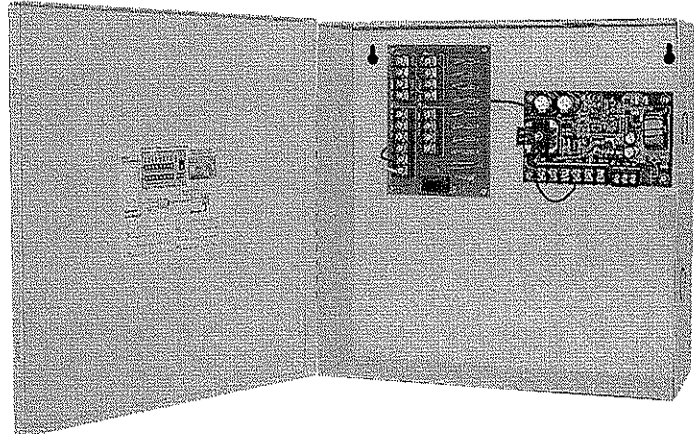

The PS-1200DCS-9 series of DC camera power supplies provide a unique series of features suited to powering high current devices, such as infrared illuminators, pan & tilt mechanisms and heaters and blowers.

The multi-output configuration allows easier installation, greater reliability and unequalled flexibility in multi-camera installations. It avoids the need to tie up one electrical outlet per camera, and provides significant advantages over multiple plug-in transformers in safety, convenience, neatness and cost.

All outputs are protected by Stealth's self-resetting *SmartFuses*. These react like a glass fuse but reset themselves when the surge has passed or the fault is removed, eliminating costly service calls to replace blown fuses. Built-in surge suppression protects your cameras from transients. A roomy metal can allows plenty of space for wiring and provides numerous knockouts for cable entry.

SPECIFICATIONS

Input Voltage: 110V AC or 220V AC

Output Voltage: 12 Volts DC

SmartFuse Rating: 3Amps per output.
10 Amp master fuse.

Current Output: 9 Amps.
Maximum 3 Amps from any one output.

Can Dimensions:
11¼ x 11¼ x 2¾ inches.

EV DVR

Most value driven DVR in the market.

EV-4000N/P

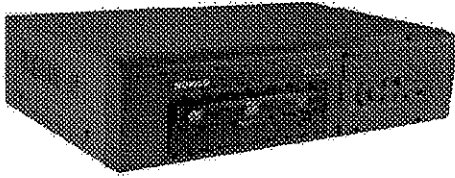

Graphic Menu



Key Features

- 4-channel
- Support NTSC & PAL Standards
- Embedded Linux Operating System
- User Friendly Graphic Menu
- Built-in Multiplexer
- Triplex Function - Simultaneous Record / Playback / Network
- MPEG-4 Compression
- Multiple Video Outputs: 1 Composite, 1 Spot, 1 VGA
- Internal HDD Bay: 1(SATA) - Up to 750GB
- Built-in Backup Device: DVD-RW
- Watch Dog / Power Failure Recovery
- Watermark
- Time Synchronization between Multiple DVRs
- 1-ch Audio with Remote Audio over Network
- Software Upgrade via USB Thumbdrive
- IR Remote Controller - Control up to 99 DVRs
- RS-422/485 for PTZ Speed Dome
- NVCK-3X, Controller Keyboard from NUVICO (Option) - Control Multiple NUVICO DVRs and PTZ Speed Domes
- Support Various PTZ Protocols
- Proprietary Dynamic DNS Service for Plug-n-Play Remote Connection

System Configuration

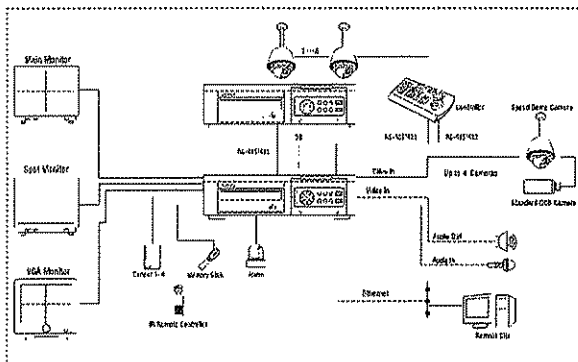

Technical Specifications

SPECIFICATIONS	EV-4000N/P
Video Format	NTSC / PAL
Operating System	Embedded Linux
Triplex Function	Simultaneous record / playback / network
Video Input	4
Monitor Output	1 Main monitor, 1 spot, 1 VGA
Video Compression Method	MPEG-4
Average File Size	2.5 ~ 8 KB
Maximum Recording Rate & Resolution	120pps @ 360 x 240(NTSC), 100pps @ 360 x 288(PAL) 60pps @ 720 x 240(NTSC), 50pps @ 720 x 288(PAL) 30pps @ 720 x 480(NTSC), 25pps @ 720 x 576(PAL)
Alarm In / Out	4 / 1
System Control	Key buttons, IR remote controller, Remote client PC, and NVCK-3X
Audio In / Out	1 / 1
PTZ Dome & Controller Interface	RS-422 / 485
FEATURES	EV-4000N/P
Display Settings	Brightness, contrast, color adjustments, hidden/covert per channel
Camera Title	12 Characters per channel
Recording Modes	Continuous, schedule, alarm, motion
Recording Adjustments	Frame rate, and picture quality adjustment per channel
Pre-Alarm & Post Alarm Recording	Pre-Alarm: 2 sec. / Post-Alarm: 10 sec. ~ 300 sec.
Motion Detection Per Channel	16 Selectable grids / 20 Sensitivity levels
Search Modes	Time & date, camera, alarm, motion
Power Failure Recovery	Auto reboot while maintaining previous record settings
E-mail Notification	External alarm, video loss, power loss, HDD failure
System Utility	Auto key lock / disk check / fan lock detection
Password	1 Admin, 5 configurable users
Backup Device	DVD-RW
MCD-Player for Backup	Auto installation into DVD during backup
Watermark	Yes
Communication Port	RS-422/485
Internal HDD Bay	1 Bay(SATA) - Up to 750GB
Network	LAN, WAN, Internet
GENERAL	EV-4000N/P
Power Input	100 ~ 230VAC(50~60Hz), Universal
Power Consumption	DC 12V, 5 Amp
Dimensions	350(W)mm x 250(D)mm x 180(H)mm
Weight	3.9 Kg
Operating Temperature	0°C ~ 40°C

Specifications are subject to change without any prior notice.

Rear View

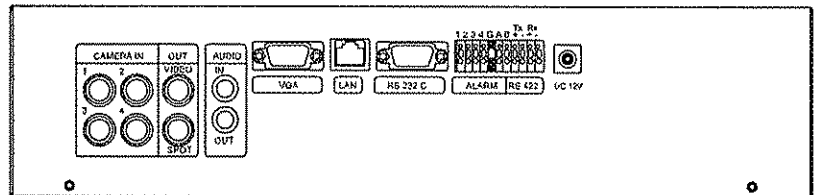

NUVICO

Corporate Headquarters: 11 366 523-1700 • 201 541-1805 • sales@nuvico.com
International Operations: 1 export@nuvico.com

Customer Service: 1 cs@nuvico.com
Technical Support: 1 techsupport@nuvico.com

EV DVR

Most value driven DVR in the market.

EV-8000N/P • EV-16000N/P

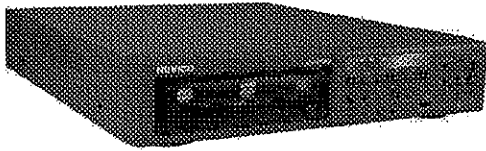

Graphic Menu



Key Features

- * 8 and 16-channel.
- * Support NTSC & PAL Standards
- * Embedded Linux Operating System
- * User Friendly Graphic Menu
- * Built-in Multiplexer
- * Triplex Function - Simultaneous Record / Playback / Network
- * MPEG-4 Compression
- * Multiple Video Outputs: 1 Composite, 1 Spot, 1 VGA
- * Internal HDD Bay: 1(SATA) - Up to 750GB
- * Built-in Backup Device: DVD-RW
- * Watch Dog / Power Failure Recovery
- * Watermark
- * Time Synchronization between Multiple DVRs
- * 1-ch Audio with Remote Audio over Network
- * Software Upgrade via USB Thumbdrive
- * IR Remote Controller - Control up to 99 DVRs
- * RS-422/485 for PTZ Speed Dome
- * NVCK-3X, Controller Keyboard from NUVICO (Option) - Control Multiple NUVICO DVRs and PTZ Speed Domes
- * Support Various PTZ Protocols
- * Proprietary Dynamic DNS Service for Plug-n-Play Remote Connection

System Configuration

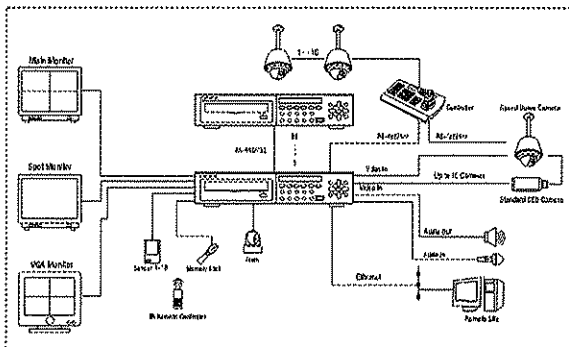

Technical Specifications

SPECIFICATIONS	EV-8000N/P	EV-16000N/P
Video Format	NTSC / PAL	
Operating System	Embedded Linux	
Triplex Function	Simultaneous record / playback / network	
Video Input	8	16
Monitor Output	1 Main monitor, 1 spot, 1 VGA	
Video Compression Method	MPEG-4	
Average File Size	2.5 ~ 8 KB	
Maximum Recording Rate & Resolution	120pps @ 360 x 240(NTSC), 100pps @ 360 x 288(PAL) 60pps @ 720 x 240(NTSC), 50pps @ 720 x 288(PAL) 30pps @ 720 x 480(NTSC), 25pps @ 720 x 576(PAL)	
Alarm In / Out	8 / 2	16 / 2
System Control	Key buttons, IR remote controller, Remote client PC, and NVCK-3X	
Audio In / Out	4 / 1	
PTZ Dome & Controller Interface	RS-422 / 485	
FUNCTIONS	EV-8000N/P	EV-16000N/P
Display Settings	Brightness, contrast, color adjustments, hidden/covert per channel	
Camera Title	12 Characters per channel	
Recording Modes	Continuous, schedule, alarm, motion	
Recording Adjustments	Frame rate and picture quality adjustment per channel	
Pre-Alarm & Post Alarm Recording	Pre-Alarm: 2 sec. / Post-Alarm: 10 sec. ~ 300 sec.	
Motion Detection Per Channel	16 Selectable grids / 20 Sensitivity levels	
Search Modes	Time & date, camera, alarm, motion	
Power Failure Recovery	Auto reboot while maintaining previous record settings	
E-mail Notification	External alarm, video loss, power loss, HDD failure	
System Utility	Auto key lock / disk check / fan lock detection	
Password	1 Admin, 5 configurable users	
Backup Device	DVD-RW	
MCD-Player for Backup	Auto installation into DVD during backup	
Watermark	Yes	
Communication Port	RS-422/485	
Internal HDD Bay	1 Bay(SATA) - Up to 750GB	
Network	LAN, WAN, Internet	
GENERAL	EV-8000N/P	EV-16000N/P
Power Input	100 ~ 240VAC(50~60Hz), Universal	
Power Consumption	DC 12V, 5 Amp	
Dimensions	335(W)mm x 398(D)mm x 70(H)mm	
Weight	4 Kg	
Operating Temperature	0°C ~ 40°C	

Specifications are subject to change without any prior notice.

Rear View

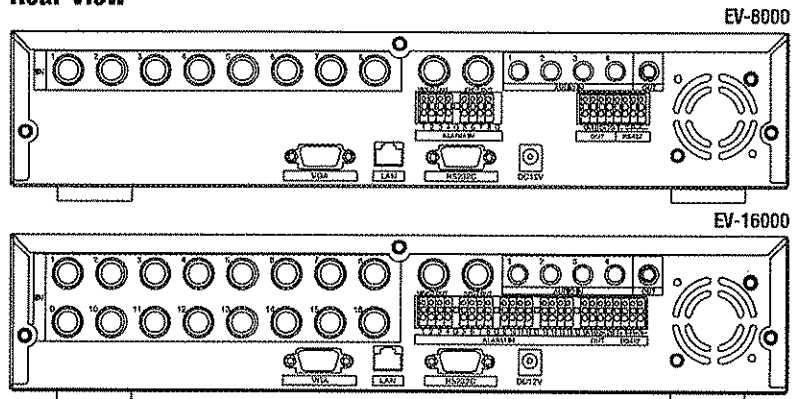

NUVICO

Corporate Headquarters | T: 866-923-1700 • 201-941-1605 • sales@nuvico.com • Customer Service | tech@nuvico.com
International Operations | Export@nuvico.com • Technical Support | techsupport@nuvico.com

EV DVR

Most value driven DVR in the market.

EV-8000N/P • EV-16000N/P

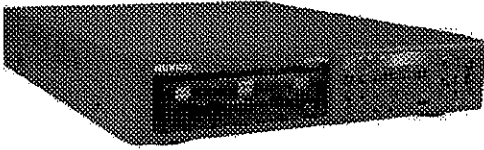

Graphic Menu

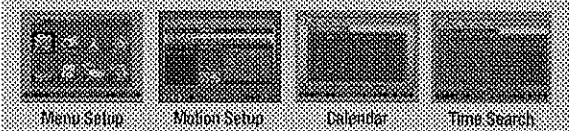

Key Features

- * 8 and 16-channel.
- * Support NTSC & PAL Standards
- * Embedded Linux Operating System
- * User Friendly Graphic Menu
- * Built-in Multiplexer
- * Triplex Function - Simultaneous Record / Playback / Network
- * MPEG-4 Compression
- * Multiple Video Outputs: 1 Composite, 1 Spot, 1 VGA
- * Internal HDD Bay: 1(SATA) - Up to 750GB
- * Built-in Backup Device: DVD-RW
- * Watch Dog / Power Failure Recovery
- * Watermark
- * Time Synchronization between Multiple DVRs
- * 1-ch Audio with Remote Audio over Network
- * Software Upgrade via USB Thumbdrive
- * IR Remote Controller - Control up to 99 DVRs
- * RS-422/485 for PTZ Speed Dome
- * NVCK-3X, Controller Keyboard from NUVICO (Option) - Control Multiple NUVICO DVRs and PTZ Speed Domes
- * Support Various PTZ Protocols
- * Proprietary Dynamic DNS Service for Plug-n-Play Remote Connection

System Configuration

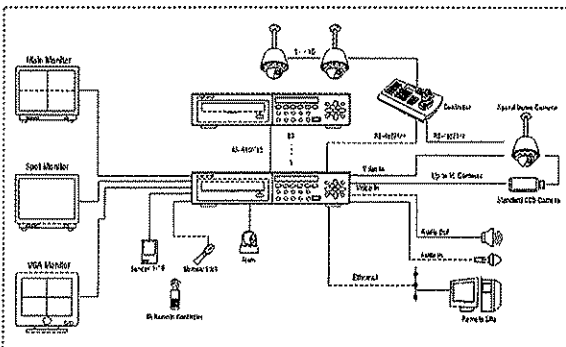

Technical Specifications

SPECIFICATIONS	EV-8000N/P	EV-16000N/P
Video Format	NTSC / PAL	
Operating System	Embedded Linux	
Triplex Function	Simultaneous record / playback / network	
Video Input	8	16
Monitor Output	1 Main monitor, 1 spot, 1 VGA	
Video Compression Method	MPEG-4	
Average File Size	2.5 ~ 8 KB	
Maximum Recording Rate & Resolution	120pps @ 360 x 240(NTSC), 100pps @ 360 x 288(PAL)	60pps @ 720 x 240(NTSC), 50pps @ 720 x 288(PAL)
	30pps @ 720 x 480(NTSC), 25pps @ 720 x 576(PAL)	
Alarm In / Out	8 / 2	16 / 2
System Control	Key buttons, IR remote controller, Remote client PC, and NVCK-3X	
Audio In / Out	4 / 1	
PTZ Dome & Controller Interface	RS-422 / 485	
FEATURES	EV-8000N/P	EV-16000N/P
Display Settings	Brightness, contrast, color adjustments, hddrv/covert per channel	
Camera Title	12 Characters per channel	
Recording Modes	Continuous, schedule, alarm, motion	
Recording Adjustments	Frame rate and picture quality adjustment per channel	
Pre-Alarm & Post Alarm Recording	Pre-Alarm: 2 sec. / Post-Alarm: 10 sec. ~ 300 sec.	
Motion Detection Per Channel	16 Selectable grids / 20 Sensitivity levels	
Search Modes	Time & date, camera, alarm, motion	
Power Failure Recovery	Auto reboot while maintaining previous record settings	
E-mail Notification	External alarm, video loss, power loss, HDD failure	
System Utility	Auto key lock / disk check / fan lock detection	
Password	1 Admin, 5 configurable users	
Backup Device	DVD-RW	
MCD-Player for Backup	Auto installation into DVD during backup	
Watermark	Yes	
Communication Port	RS-422/485	
Internal HDD Bay	1 Bay(SATA) - Up to 750GB	
Network	LAN, WAN, Internet	
GENERAL	EV-8000N/P	EV-16000N/P
Power Input	100 ~ 240VAC(50~60Hz), Universal	
Power Consumption	DC 12V, 5 Amp	
Dimensions	335(W)mm x 398(D)mm x 70(H)mm	
Weight	4 Kg	
Operating Temperature	0°C ~ 40°C	

Specifications are subject to change without any prior notice.

Rear View

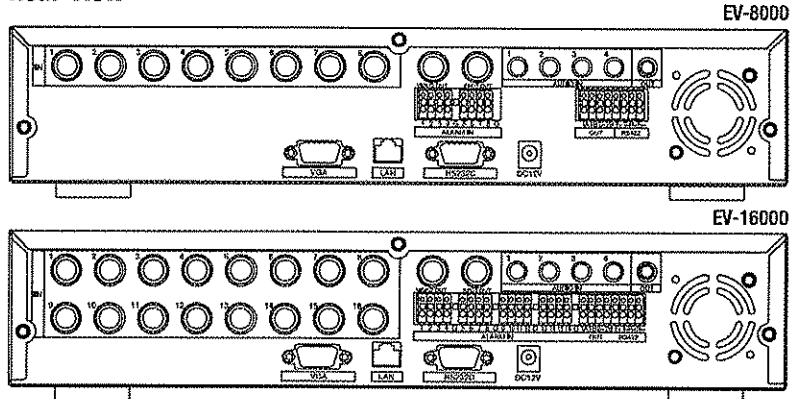

NUVICO

Corporate Headquarters: 11 866.323.1700 • 201.541.1600 • sales@nuvico.com • Customer Service: 1.877.nuvico.com
 International Operations: 1.export@nuvico.com • Technical Support: 1.techn@nuvico.com

CB-SD21N/P-L

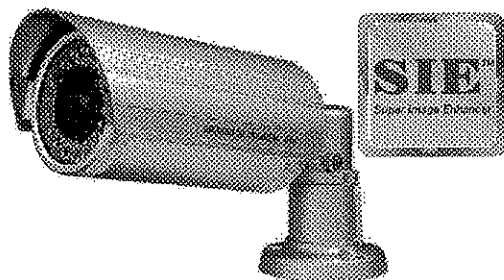

Key Features

- 1/3" CCD Sensor
- 550 TV Lines
- Day/Night function with ICR
- 2.8-10mm, DC Auto Iris
- 0.1 Lux(Color), 0.01 Lux(B/W), 0.002 Lux(DSS On)
- 36 IR LEDs
- Separate Camera Control Board
 - OSD Menu
 - Service Monitor Output
- 12VDC/24VAC Dual Voltage

Construction

- Aluminum Housing(Weatherproof)
- Aluminum Bracket(Wire feed-through)

Technical Specifications NTSC = (N), PAL = (P)

Item	CB-SD21N/P-L
Video Format	NTSC / PAL
Image Sensor	1/3" CCD
Sync System	Internal
Effective Pixels	768(H) x 494(V)(N) / 752(H) x 582(V)(P)
Scanning System	525 Lines, 2:1 Interlaced(N), 625 Lines, 2:1 Interlaced(P)
Electronic Shutter	1/60 ~ 1/120,000 sec.(N), 1/50 ~ 1/120,000 sec.(P)
Main Video Output	1.0 Vp-p Composite, 75 ohm
Service Monitor Output	1.0 Vp-p Composite, 75 ohm
Horizontal Resolution	550 TV Lines
Min. Illumination	0.1 Lux(Color), 0.01 Lux(B/W), 0.002 Lux(DSS On)
S/N Ratio	More than 50dB(AGC Off)
Lens (DC Auto Iris)	Vari-focal: 2.8-10mm
Angle of View	132.1°(W) ~ 36°(T)
Day/Night Function	ICR
36 IR LEDs	LED Distance: up to 100ft.
LED Illumination Angle	60°
Camera Control & Setup	OSD Menu
Operating Temperature	-5°C ~ +45°C
Operating Humidity	Within 90% RH
Weatherproof	IP66
Power Consumption	500mA (Camera) 1 Amp (w/ LED On)
Input Voltage	12VDC/24VAC Dual Voltage

* Must use specified and regulated 12VDC/24VAC power supply.

Dimensions (UNIT: mm)

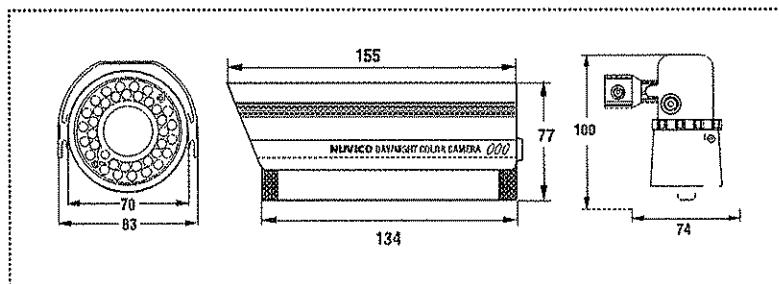

EASYVIEW