



State of West Virginia  
 Department of Administration  
 Purchasing Division  
 2019 Washington Street East  
 Post Office Box 50130  
 Charleston, WV 25305-0130

# Request for Quotation

RFQ NUMBER  
**DJS010253**

PAGE  
**1**

ADDRESS CORRESPONDENCE TO ATTENTION OF:  
**JOHN ABBOTT**  
**304-558-2544**

DEB CORV

**Longs' Security Camera Systems LLC**  
 102 38th Street SE  
 Charleston, WV 25304

**DIVISION OF JUVENILE SERVICES**  
 SECOND FLOOR  
 1200 QUARRIER STREET  
 CHARLESTON, WV 25301  
 304-558-6029

DATE PRINTED	TERMS OF SALE	SHIP VIA	F.O.B.	FREIGHT TERMS
08/13/2008				

BID OPENING DATE: **08/28/2008** BID OPENING TIME **01:30PM**

LINE	QUANTITY	UOP	CAT NO	ITEM NUMBER	UNIT PRICE	AMOUNT
0001	1	LS		840-84	<i>Aem Electronics Option #1</i>	
<p><b>VIDEO SURVEILLANCE SYSTEMS</b></p> <p>OPEN-END CONTRACT TO PROVIDE VIDEO SURVEILLANCE EQUIPMENT TO THE WEST VIRGINIA DIVISION OF JUVENILE SERVICES, PER THE SPECIFICATIONS.</p> <p>EXHIBIT 4</p> <p>LOCAL GOVERNMENT BODIES: UNLESS THE VENDOR INDICATES IN THE BID HIS REFUSAL TO EXTEND THE PRICES, TERMS, AND CONDITIONS OF THE BID TO COUNTY, SCHOOL, MUNICIPAL AND OTHER LOCAL GOVERNMENT BODIES, THE BID SHALL EXTEND TO POLITICAL SUBDIVISIONS OF THE STATE OF WEST VIRGINIA. IF THE VENDOR DOES NOT WISH TO EXTEND THE PRICES, TERMS, AND CONDITIONS OF THE BID TO ALL POLITICAL SUBDIVISIONS OF THE STATE, THE VENDOR MUST CLEARLY INDICATE SUCH REFUSAL IN HIS BID. SUCH REFUSAL SHALL NOT PREJUDICE THE AWARD OF THIS CONTRACT IN ANY MANNER.</p> <p>REV. 3/88</p> <p>EXHIBIT 3</p> <p>LIFE OF CONTRACT: THIS CONTRACT BECOMES EFFECTIVE ON ..... AND EXTENDS FOR A PERIOD OF ONE (1) YEAR OR UNTIL SUCH "REASONABLE TIME" THEREAFTER AS IS NECESSARY TO OBTAIN A NEW CONTRACT OR RENEW THE ORIGINAL CONTRACT. THE "REASONABLE TIME" PERIOD SHALL NOT EXCEED TWELVE (12) MONTHS. DURING THIS "REASONABLE</p>						

**RECEIVED**  
 08 AUG 28 AM 11:14  
 PURCHASING DIVISION  
 STATE OF WV

SEE REVERSE SIDE FOR TERMS AND CONDITIONS

SIGNATURE: *Alan E. Arns* TELEPHONE: **304-925-0338** DATE: **08-28-08**

TITLE: *Owner* FEIN: **20-388100-001** ADDRESS CHANGES TO BE NOTED ABOVE

WHEN RESPONDING TO RFQ, INSERT NAME AND ADDRESS IN SPACE ABOVE LABELED 'VENDOR'

**BID SUBMISSION WORKSHEET FOR  
DJS 010253  
ALL QUANTITIES ARE ESTIMATES ONLY**

ITEM  
NO.

	ESTIMATED QUANTITY	ITEM	MODEL	UNIT PRICE	AMOUNT
1.	90	COLOR VARI-FOCAL MINI DOME CAMERA	CS40MD VAI	170.55	15,349.64
2.	20	COLOR VARI-FOCAL DAY/NIGHT INFRARED MINI DOME CAMERA	CS40MD VAI DNIIR	261.13	5,222.55
3.	10	16 CAMERA 12VCD POWER SUPPLY	DCR1681UL	120.16	1,201.58
4.	5	8 CAMERA 12VCD POWER SUPPLY	DCR841UL	60.61	303.03
5.	5	4 CAMERA 12VCD POWER SUPPLY	DCR441UL	53.56	267.79
6.	5	4 CHANNEL NETWORKABLE TRIPLEX DVR WITH CD-R/W	JDVR4A 500CD	1,189.70	5,948.49
7.	5	8 CHANNEL NETWORKABLE TRIPLEX DVR WITH CD-R/W	JDVR8A 500CD	1,301.75	6,508.76
8.	10	16 CHANNEL NETWORKABLE TRIPLEX DVR WITH CD-R/W	JDVR16A 500CD	1,504.61	15,046.05
9.	20	COLOR VARI-FOCAL INFRARED BULLET CAMERA	CB20BC DNVPIR	221.06	4,421.13

TOTAL      \$ 54,269.01



State of West Virginia  
 Department of Administration  
 Purchasing Division  
 2019 Washington Street East  
 Post Office Box 50130  
 Charleston, WV 25305-0130

**Request for  
 Quotation**

RFQ NUMBER  
**DJS010253**

PAGE  
**2**

ADDRESS CORRESPONDENCE TO ATTENTION OF  
**JOHN ABBOTT  
 304-558-2544**

VENDOR

RFQ COPY  
 TYPE NAME/ADDRESS HERE

SHIP TO

DIVISION OF JUVENILE SERVICES  
 SECOND FLOOR  
 1200 QUARRIER STREET  
 CHARLESTON, WV  
 25301 304-558-6029

DATE PRINTED	TERMS OF SALE	SHIP VIA	FOB	FREIGHT TERMS
08/13/2008				

BID OPENING DATE: **08/28/2008** BID OPENING TIME **01:30PM**

LINE	QUANTITY	UOP	CAT NO.	ITEM NUMBER	UNIT PRICE	AMOUNT
<p>TIME" THE VENDOR MAY TERMINATE THIS CONTRACT FOR ANY REASON UPON GIVING THE DIRECTOR OF PURCHASING 30 DAYS WRITTEN NOTICE.</p> <p>UNLESS SPECIFIC PROVISIONS ARE STIPULATED ELSEWHERE IN THIS CONTRACT DOCUMENT, THE TERMS, CONDITIONS AND PRICING SET HEREIN ARE FIRM FOR THE LIFE OF THE CONTRACT.</p> <p>RENEWAL: THIS CONTRACT MAY BE RENEWED UPON THE MUTUAL WRITTEN CONSENT OF THE SPENDING UNIT AND VENDOR, SUBMITTED TO THE DIRECTOR OF PURCHASING THIRTY (30) DAYS PRIOR TO THE EXPIRATION DATE. SUCH RENEWAL SHALL BE IN ACCORDANCE WITH THE TERMS AND CONDITIONS OF THE ORIGINAL CONTRACT AND SHALL BE LIMITED TO TWO (2) ONE (1) YEAR PERIODS.</p> <p>CANCELLATION: THE DIRECTOR OF PURCHASING RESERVES THE RIGHT TO CANCEL THIS CONTRACT IMMEDIATELY UPON WRITTEN NOTICE TO THE VENDOR IF THE COMMODITIES AND/OR SERVICES SUPPLIED ARE OF AN INFERIOR QUALITY OR DO NOT CONFORM TO THE SPECIFICATIONS OF THE BID AND CONTRACT HEREIN.</p> <p>OPEN MARKET CLAUSE: THE DIRECTOR OF PURCHASING MAY AUTHORIZE A SPENDING UNIT TO PURCHASE ON THE OPEN MARKET, WITHOUT THE FILING OF A REQUISITION OR COST ESTIMATE, ITEMS SPECIFIED ON THIS CONTRACT FOR IMMEDIATE DELIVERY IN EMERGENCIES DUE TO UNFORESEEN CAUSES (INCLUDING BUT NOT LIMITED TO DELAYS IN TRANSPORTATION OR AN UNANTICIPATED INCREASE IN THE VOLUME OF WORK.)</p> <p>QUANTITIES: QUANTITIES LISTED IN THE REQUISITION ARE APPROXIMATIONS ONLY, BASED ON ESTIMATES SUPPLIED BY THE STATE SPENDING UNIT. IT IS UNDERSTOOD AND AGREED THAT THE CONTRACT SHALL COVER THE QUANTITIES ACTUALLY</p>						

SEE REVERSE SIDE FOR TERMS AND CONDITIONS

SIGNATURE	TELEPHONE	DATE
TITLE	FEIN	ADDRESS CHANGES TO BE NOTED ABOVE

WHEN RESPONDING TO RFQ, INSERT NAME AND ADDRESS IN SPACE ABOVE LABELED 'VENDOR'



State of West Virginia  
 Department of Administration  
 Purchasing Division  
 2019 Washington Street East  
 Post Office Box 50130  
 Charleston, WV 25305-0130

# Request for Quotation

RFQ NUMBER  
**DJS010253**

PAGE  
**3**

ADDRESS CORRESPONDENCE TO ATTENTION OF  
**JOHN ABBOTT**  
**304-558-2544**

VENDOR

RFQ COPY  
 TYPE NAME/ADDRESS HERE

BUYER

DIVISION OF JUVENILE SERVICES  
 SECOND FLOOR  
 1200 QUARRIER STREET  
 CHARLESTON, WV  
 25301 304-558-6029

DATE PRINTED	TERMS OF SALE	SHIP VIA	F.O.B.	FREIGHT TERMS
08/13/2008				
BID OPENING DATE: 08/28/2008		BID OPENING TIME 01:30PM		

LINE	QUANTITY	UOP	CAT NO.	ITEM NUMBER	UNIT PRICE	AMOUNT
<p>ORDERED FOR DELIVERY DURING THE TERM OF THE CONTRACT, WHETHER MORE OR LESS THAN THE QUANTITIES SHOWN.</p> <p>ORDERING PROCEDURE: SPENDING UNIT(S) SHALL ISSUE A WRITTEN STATE CONTRACT ORDER (FORM NUMBER WV-39) TO THE VENDOR FOR COMMODITIES COVERED BY THIS CONTRACT. THE ORIGINAL COPY OF THE WV-39 SHALL BE MAILED TO THE VENDOR AS AUTHORIZATION FOR SHIPMENT, A SECOND COPY MAILED TO THE PURCHASING DIVISION, AND A THIRD COPY RETAINED BY THE SPENDING UNIT.</p> <p>BANKRUPTCY: IN THE EVENT THE VENDOR/CONTRACTOR FILES FOR BANKRUPTCY PROTECTION, THIS CONTRACT IS AUTOMATICALLY NULL AND VOID, AND IS TERMINATED WITHOUT FURTHER ORDER.</p> <p>THE TERMS AND CONDITIONS CONTAINED IN THIS CONTRACT SHALL SUPERSEDE ANY AND ALL SUBSEQUENT TERMS AND CONDITIONS WHICH MAY APPEAR ON ANY ATTACHED PRINTED DOCUMENTS SUCH AS PRICE LISTS, ORDER FORMS, SALES AGREEMENTS OR MAINTENANCE AGREEMENTS, INCLUDING ANY ELECTRONIC MEDIUM SUCH AS CD-ROM.</p> <p>REV. 04/11/2001</p> <p style="text-align: center;">VENDOR PREFERENCE CERTIFICATE</p> <p>CERTIFICATION AND APPLICATION* IS HEREBY MADE FOR PREFERENCE IN ACCORDANCE WITH WEST VIRGINIA CODE, 5A-3-37 (DOES NOT APPLY TO CONSTRUCTION CONTRACTS).</p> <p>A. APPLICATION IS MADE FOR 2.5% PREFERENCE FOR THE REASON CHECKED:</p> <p>(*) BIDDER IS AN INDIVIDUAL RESIDENT VENDOR AND HAS RESIDED CONTINUOUSLY IN WEST VIRGINIA FOR FOUR</p>						

SEE REVERSE SIDE FOR TERMS AND CONDITIONS

SIGNATURE	TELEPHONE	DATE
TITLE	FEIN	ADDRESS CHANGES TO BE NOTED ABOVE

WHEN RESPONDING TO RFQ, INSERT NAME AND ADDRESS IN SPACE ABOVE LABELED 'VENDOR'



State of West Virginia  
 Department of Administration  
 Purchasing Division  
 2019 Washington Street East  
 Post Office Box 50130  
 Charleston, WV 25305-0130

# Request for Quotation

RFQ NUMBER:  
**DJS010253**

PAGE  
**4**

ADDRESS CORRESPONDENCE TO ATTENTION OF:  
**JOHN ABBOTT  
 304-558-2544**

VENDOR

RFQ COPY  
 TYPE NAME/ADDRESS HERE

VENDOR

**DIVISION OF JUVENILE SERVICES  
 SECOND FLOOR  
 1200 QUARRIER STREET  
 CHARLESTON, WV  
 25301 304-558-6029**

DATE PRINTED	TERMS OF SALE	SHIP VIA	F.O.B.	FREIGHT TERMS
08/13/2008				

BID OPENING DATE: **08/28/2008** BID OPENING TIME **01:30PM**

LINE	QUANTITY	UOP	CAT NO.	ITEM NUMBER	UNIT PRICE	AMOUNT
<p>(4) YEARS IMMEDIATELY PRECEDING THE DATE OF THIS CERTIFICATION; OR</p> <p>( ) BIDDER IS A PARTNERSHIP, ASSOCIATION OR CORPORATION RESIDENT VENDOR AND HAS MAINTAINED ITS HEAD-QUARTERS OR PRINCIPAL PLACE OF BUSINESS CONTINUOUSLY IN WEST VIRGINIA FOR FOUR (4) YEARS IMMEDIATELY PRECEDING THE DATE OF THIS CERTIFICATION; OR 80% OF THE OWNERSHIP INTEREST OF BIDDER IS HELD BY ANOTHER INDIVIDUAL, PARTNERSHIP, ASSOCIATION OR CORPORATION RESIDENT VENDOR WHO HAS MAINTAINED ITS HEADQUARTERS OR PRINCIPAL PLACE OF BUSINESS CONTINUOUSLY IN WEST VIRGINIA FOR FOUR (4) YEARS IMMEDIATELY PRECEDING THE DATE OF THIS CERTIFICATION; OR</p> <p>( ) BIDDER IS A CORPORATION NONRESIDENT VENDOR WHICH HAS AN AFFILIATE OR SUBSIDIARY WHICH EMPLOYS A MINIMUM OF ONE HUNDRED STATE RESIDENTS AND WHICH HAS MAINTAINED ITS HEADQUARTERS OR PRINCIPAL PLACE OF BUSINESS WITHIN WEST VIRGINIA CONTINUOUSLY FOR THE FOUR (4) YEARS IMMEDIATELY PRECEDING THE DATE OF THIS CERTIFICATION.</p> <p>B. APPLICATION IS MADE FOR 2.5% PREFERENCE FOR THE REASON CHECKED:</p> <p><input checked="" type="checkbox"/> BIDDER IS A RESIDENT VENDOR WHO CERTIFIES THAT, DURING THE LIFE OF THE CONTRACT, ON AVERAGE AT LEAST 75% OF THE EMPLOYEES WORKING ON THE PROJECT BEING BID ARE RESIDENTS OF WEST VIRGINIA WHO HAVE RESIDED IN THE STATE CONTINUOUSLY FOR THE TWO YEARS IMMEDIATELY PRECEDING SUBMISSION OF THIS BID;  OR  ( ) BIDDER IS A NONRESIDENT VENDOR EMPLOYING A MINIMUM OF ONE HUNDRED STATE RESIDENTS OR IS A NONRESIDENT VENDOR WITH AN AFFILIATE OR SUBSIDIARY</p>						

SEE REVERSE SIDE FOR TERMS AND CONDITIONS

SIGNATURE	TELEPHONE	DATE
-----------	-----------	------

TITLE	FEIN	ADDRESS CHANGES TO BE NOTED ABOVE
-------	------	-----------------------------------

WHEN RESPONDING TO RFQ, INSERT NAME AND ADDRESS IN SPACE ABOVE LABELED 'VENDOR'



State of West Virginia  
 Department of Administration  
 Purchasing Division  
 2019 Washington Street East  
 Post Office Box 50130  
 Charleston, WV 25305-0130

**Request for  
 Quotation**

RFQ NUMBER  
**DJS010253**

PAGE  
**5**

ADDRESS CORRESPONDENCE TO ATTENTION OF  
**JOHN ABBOTT  
 304-558-2544**

VENDOR

RFQ COPY  
 TYPE NAME/ADDRESS HERE

SHIP TO

**DIVISION OF JUVENILE SERVICES  
 SECOND FLOOR  
 1200 QUARRIER STREET  
 CHARLESTON, WV  
 25301 304-558-6029**

DATE PRINTED <b>08/13/2008</b>	TERMS OF SALE	SHIP VIA	F.O.B.	FREIGHT TERMS
-----------------------------------	---------------	----------	--------	---------------

BID OPENING DATE: **08/28/2008** BID OPENING TIME **01:30PM**

LINE	QUANTITY	UOP	CAT NO	ITEM NUMBER	UNIT PRICE	AMOUNT
<p>WHICH MAINTAINS ITS HEADQUARTERS OR PRINCIPAL PLACE OF BUSINESS WITHIN WEST VIRGINIA EMPLOYING A MINIMUM OF ONE HUNDRED STATE RESIDENTS WHO CERTIFIES THAT, DURING THE LIFE OF THE CONTRACT, ON AVERAGE AT LEAST 75% OF THE EMPLOYEES OR BIDDERS' AFFILIATE'S OR SUBSIDIARY'S EMPLOYEES ARE RESIDENTS OF WEST VIRGINIA WHO HAVE RESIDED IN THE STATE CONTINUOUSLY FOR THE TWO YEARS IMMEDIATELY PRECEDING SUBMISSION OF THIS BID.</p> <p>BIDDER UNDERSTANDS IF THE SECRETARY OF TAX &amp; REVENUE DETERMINES THAT A BIDDER RECEIVING PREFERENCE HAS FAILED TO CONTINUE TO MEET THE REQUIREMENTS FOR SUCH PREFERENCE, THE SECRETARY MAY ORDER THE DIRECTOR OF PURCHASING TO: (A) RESCIND THE CONTRACT OR PURCHASE ORDER ISSUED; OR (B) ASSESS A PENALTY AGAINST SUCH BIDDER IN AN AMOUNT NOT TO EXCEED 5% OF THE BID AMOUNT AND THAT SUCH PENALTY WILL BE PAID TO THE CONTRACTING AGENCY OR DEDUCTED FROM ANY UNPAID BALANCE ON THE CONTRACT OR PURCHASE ORDER.</p> <p>BY SUBMISSION OF THIS CERTIFICATE, BIDDER AGREES TO DISCLOSE ANY REASONABLY REQUESTED INFORMATION TO THE PURCHASING DIVISION AND AUTHORIZES THE DEPARTMENT OF TAX AND REVENUE TO DISCLOSE TO THE DIRECTOR OF PURCHASING APPROPRIATE INFORMATION VERIFYING THAT BIDDER HAS PAID THE REQUIRED BUSINESS TAXES, PROVIDED THAT SUCH INFORMATION DOES NOT CONTAIN THE AMOUNTS OF TAXES PAID NOR ANY OTHER INFORMATION DEEMED BY THE TAX COMMISSIONER TO BE CONFIDENTIAL.</p> <p>UNDER PENALTY OF LAW FOR FALSE SWEARING (WEST VIRGINIA CODE 61-5-3), BIDDER HEREBY CERTIFIES THAT THIS CERTIFICATE IS TRUE AND ACCURATE IN ALL RESPECTS; AND THAT IF A CONTRACT IS ISSUED TO BIDDER AND IF ANYTHING CONTAINED WITHIN THIS CERTIFICATE CHANGES DURING THE TERM OF THE CONTRACT, BIDDER WILL NOTIFY THE</p>						

SEE REVERSE SIDE FOR TERMS AND CONDITIONS

SIGNATURE	TELEPHONE	DATE
TITLE	FEIN	ADDRESS CHANGES TO BE NOTED ABOVE

WHEN RESPONDING TO RFQ, INSERT NAME AND ADDRESS IN SPACE ABOVE LABELED 'VENDOR'



State of West Virginia  
 Department of Administration  
 Purchasing Division  
 2019 Washington Street East  
 Post Office Box 50130  
 Charleston, WV 25305-0130

# Request for Quotation

RFQ NUMBER  
**DJS010253**

PAGE  
**6**

ADDRESS CORRESPONDENCE TO ATTENTION OF  
**JOHN ABBOTT**  
**304-558-2544**

VENDOR

RFQ COPY  
 TYPE NAME/ADDRESS HERE

SHIP TO

**DIVISION OF JUVENILE SERVICES**  
**SECOND FLOOR**  
**1200 QUARRIER STREET**  
**CHARLESTON, WV**  
**25301**      **304-558-6029**

DATE PRINTED	TERMS OF SALE	SHIP VIA	F.O.B.	FREIGHT TERMS
08/13/2008				

BID OPENING DATE: **08/28/2008**      BID OPENING TIME **01:30PM**

LINE	QUANTITY	UOP	CAT. NO.	ITEM NUMBER	UNIT PRICE	AMOUNT
PURCHASING DIVISION IN WRITING IMMEDIATELY.						
BIDDER: <u>Long's Security Camera Systems LLC</u>						
DATE: <u>08-28-08</u>						
SIGNED: <u>Alon E. Long</u>						
TITLE: <u>Owner</u>						
* CHECK ANY COMBINATION OF PREFERENCE CONSIDERATION(S) IN EITHER "A" OR "B", OR BOTH "A" AND "B" WHICH YOU ARE ENTITLED TO RECEIVE. YOU MAY REQUEST UP TO THE MAXIMUM 5% PREFERENCE FOR BOTH "A" AND "B". (REV. 12/00)						
NOTICE						
A SIGNED BID MUST BE SUBMITTED TO:						
DEPARTMENT OF ADMINISTRATION PURCHASING DIVISION BUILDING 15 2019 WASHINGTON STREET, EAST CHARLESTON, WV 25305-0130						
THE BID SHOULD CONTAIN THIS INFORMATION ON THE FACE OF THE ENVELOPE OR THE BID MAY NOT BE CONSIDERED:						
SEE REVERSE SIDE FOR TERMS AND CONDITIONS						

SIGNATURE	TELEPHONE	DATE
TITLE	FEIN	ADDRESS CHANGES TO BE NOTED ABOVE

WHEN RESPONDING TO RFQ, INSERT NAME AND ADDRESS IN SPACE ABOVE LABELED 'VENDOR'



State of West Virginia  
 Department of Administration  
 Purchasing Division  
 2019 Washington Street East  
 Post Office Box 50130  
 Charleston, WV 25305-0130

# Request for Quotation

RFQ NUMBER  
**DJS010253**

PAGE  
**7**

ADDRESS CORRESPONDENCE TO ATTENTION OF  
**JOHN ABBOTT**  
**304-558-2544**

VENDOR

RFQ COPY  
 TYPE NAME/ADDRESS HERE

SHIP TO

DIVISION OF JUVENILE SERVICES  
 SECOND FLOOR  
 1200 QUARRIER STREET  
 CHARLESTON, WV  
 25301 304-558-6029

DATE PRINTED	TERMS OF SALE	SHIP VIA	F.O.B.	FREIGHT TERMS
08/13/2008				

BID OPENING DATE: **08/28/2008** BID OPENING TIME **01:30PM**

LINE	QUANTITY	UOP	CAT NO	ITEM NUMBER	UNIT PRICE	AMOUNT
SEALED BID						
BUYER:				JOHN ABBOTT-----		
RFQ. NO.:				DJS010253-----		
BID OPENING DATE:				08/28/2008-----		
BID OPENING TIME:				1:30 PM-----		
PLEASE PROVIDE A FAX NUMBER IN CASE IT IS NECESSARY TO CONTACT YOU REGARDING YOUR BID:						
				304-925-0338-----		
CONTACT PERSON (PLEASE PRINT CLEARLY):						
				MIAN E LONG-----		
***** THIS IS THE END OF RFQ DJS010253 ***** TOTAL: _____						

SEE REVERSE SIDE FOR TERMS AND CONDITIONS

SIGNATURE	TELEPHONE	DATE
TITLE	FEIN	ADDRESS CHANGES TO BE NOTED ABOVE

WHEN RESPONDING TO RFQ, INSERT NAME AND ADDRESS IN SPACE ABOVE LABELED 'VENDOR'



STATE OF WEST VIRGINIA  
Purchasing Division

## PURCHASING AFFIDAVIT

### VENDOR OWING A DEBT TO THE STATE:

*West Virginia Code* §5A-3-10a provides that: No contract or renewal of any contract may be awarded by the state or any of its political subdivisions to any vendor or prospective vendor when the vendor or prospective vendor or a related party to the vendor or prospective vendor is a debtor and the debt owed is an amount greater than one thousand dollars in the aggregate.

### PUBLIC IMPROVEMENT CONTRACTS & DRUG-FREE WORKPLACE ACT:

*West Virginia Code* §21-1D-5 provides that: Any solicitation for a public improvement construction contract shall require each vendor that submits a bid for the work to submit at the same time an affidavit that the vendor has a written plan for a drug-free workplace policy in compliance with Article 1D, Chapter 21 of the West Virginia Code. A public improvement construction contract may not be awarded to a vendor who does not have a written plan for a drug-free workplace policy in compliance with Article 1D, Chapter 21 of the West Virginia Code and who has not submitted that plan to the appropriate contracting authority in timely fashion. For a vendor who is a subcontractor, compliance with Section 5, Article 1D, Chapter 21 of the West Virginia Code may take place before their work on the public improvement is begun.

### ANTITRUST:

In submitting a bid to any agency for the state of West Virginia, the bidder offers and agrees that if the bid is accepted the bidder will convey, sell, assign or transfer to the state of West Virginia all rights, title and interest in and to all causes of action it may now or hereafter acquire under the antitrust laws of the United States and the state of West Virginia for price fixing and/or unreasonable restraints of trade relating to the particular commodities or services purchased or acquired by the state of West Virginia. Such assignment shall be made and become effective at the time the purchasing agency tenders the initial payment to the bidder.

I certify that this bid is made without prior understanding, agreement, or connection with any corporation, firm, limited liability company, partnership or person or entity submitting a bid for the same materials, supplies, equipment or services and is in all respects fair and without collusion or fraud. I further certify that I am authorized to sign the certification on behalf of the bidder or this bid.

### LICENSING:

Vendors must be licensed and in good standing in accordance with any and all state and local laws and requirements by any state or local agency of West Virginia, including, but not limited to, the West Virginia Secretary of State's Office, the West Virginia Tax Department, West Virginia Insurance Commission, or any other state agencies or political subdivision. Furthermore, the vendor must provide all necessary releases to obtain information to enable the Director or spending unit to verify that the vendor is licensed and in good standing with the above entities.

### CONFIDENTIALITY:

The vendor agrees that he or she will not disclose to anyone, directly or indirectly, any such personally identifiable information or other confidential information gained from the agency, unless the individual who is the subject of the information consents to the disclosure in writing or the disclosure is made pursuant to the agency's policies, procedures and rules. Vendors should visit [www.state.wv.us/admin/purchase/privacy](http://www.state.wv.us/admin/purchase/privacy) for the Notice of Agency Confidentiality Policies.

Under penalty of law for false swearing (West Virginia Code §61-5-3), it is hereby certified that the vendor acknowledges the information in this said affidavit and is in compliance with the requirements as stated.

Vendor's Name: Long Security Camera Systems LLC

Authorized Signature: Alan E Long Date: 08-28-08

# 1/3" DSP COLOR VARI-FOCAL DOME CAMERA

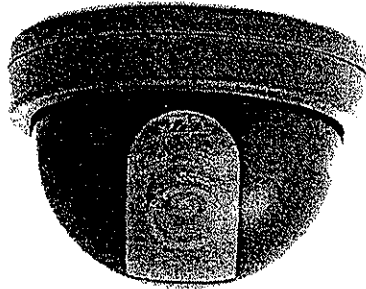

## Specifications

C540MD2VAI

MODEL NO.	C540MD2VAI
POWER SOURCE	DUAL VOLTAGE (12 V DC and 24 V AC)60Hz
IMAGE PICK -UP DEVICE	1/3" SONY SUPER HAD CCD (NTSC) 768(H) x 494(V)
SCANNING SYSTEM.	2:1 INTERLACE 525LINES / 60FIELDS / 30FRAMES
VIDEO OUTPUT	1.0V (p-p) NTSC COMPOSITE
Min. Illumination	0.7 LUX at F1.2 (AGC ON)
RESOLUTION	More Than 540TV LINE (HORIZONTAL)
BACK LIGHT COMPENSATION	BUILT-IN (ON)
ELECTRONIC SHUTTER	1/60 ~ 1/100,000 sec
WHITE BALANCE	A W B
LENS TYPE	2.6-6mm Varifocal Auto Iris lens (Option Lens : 3.8-9.5mm, 3.7-12mm, 4-9mm)
AGC	BUILT-IN (ON)
S / N RATIO	MORE THAN 48dB (AGC OFF)
OPERATION TEMPERATURE	-10°C ~ + 50°C
WEIGHT	420g/ 14.170z/1.1Lbs, Size: 120(OD)mm*99mm(H) (4.72inch * 3.891inch)

- 1. 3 Axis (X-Y-Z) fo PAN-TILT-TWIST provides new angles to Dome camera
  - Rotational twisting fo camera optics
  - Instant directional positioning of the CCD and its lens
  - New dimensions of convenience, functionality and esy forinstallation

# 1/3" DSP COLOR VARI-FOCAL DOME CAMERA

## 1. Decoration Ring



The ring is assembled and protected the glass and housing base

## 2. Polycarbonate Housing Dome

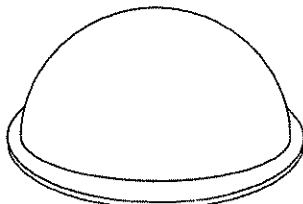

The Polycarbonate glass (pellucid and smoked type) housing dome has the function of hi-impacted vandal proof. Please fix the dome cover on the base by cover decoration ring

## 3. Cover of polycarbonate glass

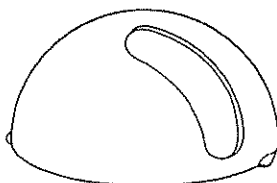

The cover of polycarbonate glass is fixed the angles of CCD camera

## 4. 3 Axis (X-Y-Z) holder

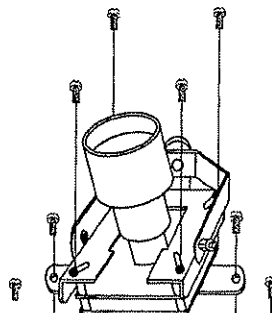

3Axis(X-Y-Z) PAN-Tilt-Twisting camera holder provides New Angles to Vari-focal dome camera. The 3Axis PTT holder enables versatile X-Y-Z positioning of various CCD board module cameras—even to capture surveillance from straight along walls and corridors

## 5. Housing Base

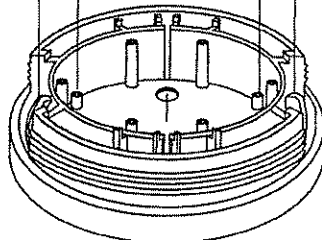

We provide the female BNC video and terminal block power adaptor connector cables  
The 2 big screw holes of side the housing base may install to the ceiling and corridors with functionality & ease for installation

### Caution

**RISK OF ELECTRICAL SHOCK ! DO NOT OPEN!**

### SAFETY CONSIDERATIONS:

Don't touch the CCD Chip with your fingers  
Use the camera only with the correct power supply which the manufacturer is required  
Use a monitor with 75 ohm impedance

### INSTALLATION STEPS:

- 1) Mount the camera securely
- 2) Connect video using suitable coaxial cable with BNC-connector
- 3) Connect the camera to a correct power supply which the manufacturer is required

*Do not attempt to disassemble the camera.*

*To prevent electric shock, do not remove screws or cover. There are no user-serviceable parts inside. Refer servicing to qualified service personnel*

*Handle the camera with care*

*Do not abuse the camera. Avoid striking or shaking it. The camera could be damaged by improper handling or storage  
Do not expose the camera to rain or moisture, or try to operate it in wet areas*

*Take immediate action if ever the camera does become wet  
Turn power off and refer servicing to qualified service personnel  
Moisture can damage the camera and also create the danger of electric shock*

*Never face the camera toward the sun*

*Whether the camera is in use or not, never face it toward the sun. Use caution when operating the camera in the vicinity of spot lights or other blight lights and light reflecting objects*

# Function Key Vari-Focal Lens

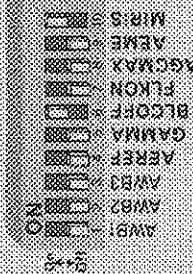
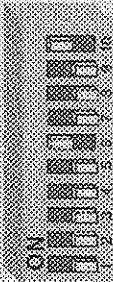

- \* Factory speed select
- AE: Automatic Electronic Shutter Speed
- AE: Manual Electronic Shutter Speed
- FL: Flicker less mode
- BIC: Back Light Compensation mode
- \* Lens select
- E: Iris: Electronic shutter speed light sensitive lens
- M: Iris: Mechanical Iris Light sensitive Lens 0
- \* Video Output Signal Level Select
- AE REF: Auto-Exposure Value output signal Reference Level
- GAMMA: Gamma (touching GAMMA Value setting)
- AGC MAX: A: Automatic Gain Control; Maximum Gain Value Setting

Key No. Location	9	7	6	5	4	3	2	1
ON	AE Mode	FL On	TEG Off	AE REF	AE REF	AE REF	AE REF	AE REF
OFF	AE Mode	FL Off	TEG On	150 Hz	150 Hz	150 Hz	150 Hz	150 Hz
ON	AE Mode	FL On	TEG Off	1	2	3	4	5
OFF	AE Mode	FL Off	TEG On	1	2	3	4	5

SHUT	SHUTS	Electronic Shutter Speed	Value
OFF	OFF	1/60(NTSC)	1/60(NTSC)
ON	OFF	1/120(NTSC)	1/120(NTSC)
ON	ON	1/250 (PAL)	1/250 (PAL)
ON	ON	1/500 (PAL)	1/500 (PAL)
ON	ON	1/1000 (PAL)	1/1000 (PAL)
ON	ON	1/2000 (PAL)	1/2000 (PAL)
ON	ON	1/4000 (PAL)	1/4000 (PAL)
ON	ON	1/8000 (PAL)	1/8000 (PAL)

SHUT	SHUTS	Electronic Shutter Speed	Value
OFF	OFF	1/60 (PAL)	1/60 (PAL)
ON	ON	1/120 (PAL)	1/120 (PAL)
ON	ON	1/250 (PAL)	1/250 (PAL)
ON	ON	1/500 (PAL)	1/500 (PAL)
ON	ON	1/1000 (PAL)	1/1000 (PAL)
ON	ON	1/2000 (PAL)	1/2000 (PAL)
ON	ON	1/4000 (PAL)	1/4000 (PAL)
ON	ON	1/8000 (PAL)	1/8000 (PAL)

## \* AWB : Auto White Balance

Key No. Location	1	2	3
ON	AWB1	AWB2	AWB3
OFF	AWB1	AWB2	AWB3

White Balance Adjustment			
AWB1	AWB2	AWB3	WB ADJUST
OFF	OFF	OFF	ASSTD
ON	ON	OFF	PRESET
ON	ON	ON	LOCK/ABS
ON	ON	ON	WHITE BALANCE
ON	ON	ON	AutoWhite
ON	ON	ON	WhiteBalance
ON	ON	ON	Factory
ON	ON	ON	Factory

\* The "Blue Gain UP" key shifts toward the high color temperature side and the "Red Gain UP" key shifts toward the low color temperature side.

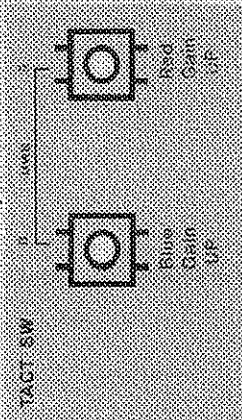

## <Initial Location (Factory Setting Mode)>

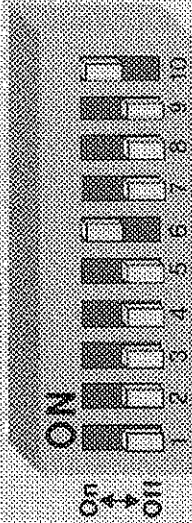

AWB1  
AWB2  
AWB3  
AEREF  
GAMMA  
BLCOFF  
FLKON  
AGCMAX  
AEME  
MIRIS

# 1/3" DSP COLOR VARI-FOCAL DOME CAMERA

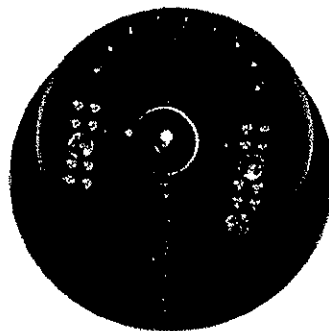

## Specifications

C540MDVAIDNIR

MODEL NO.	C540MDVAIDNIR
POWER SOURCE	DUAL VOLTAGE (12 V DC and 24 V AC), 60Hz
IMAGE PICK -UP DEVICE	1/3" SONY SUPER HAD CCD 768(H) x 494(V)
SCANNING SYSTEM.	2:1 INTERLACE 525LINES / 60FIELDS / 30FRAMES
VIDEO OUTPUT	1.0V (p-p) NTSC COMPOSITE
Min. Illumination	0.01 LUX at F1.2 (AGC ON)
RESOLUTION	More Than 540TV LINE (HORIZONTAL)
BACK LIGHT COMPENSATION	BUILT-IN (ON)
ELECTRONIC SHUTTER	1/60 ~ 1/100,000 sec
WHITE BALANCE	A W B
LENS TYPE	True Day & Night 3.7~12mm IR Cut Filter Lens
AGC	BUILT-IN (ON)
Synchronization SYSTEM	INTERNAL
S / N RATIO	MORE THAN 50dB (AGC OFF)
OPERATION TEMPERATURE	-10°C ~ +50°C
WEIGHT	420g/ 14.170z/1.1Lbs, Size: 120(OD)mm*99mm(H) (4.72inch * 3.89inch)

1. 3 Axis (X-Y-Z) fo PAN-TILT-TWIST provides new angles to Dome camera

Rotational twisting fo camera optics

Instant directional positioning of the CCD and its lens

New dimensions of convenience, functionality and esy for installation

2. IR Range : Up to 30M (90 feet) using 28 pcs of IR-LEDs

( Include 3 pcs of Super IR-LEDs)

3. Synchronization System: INTERNAL

4. 10pcs Slide Switch mode

5. Tact Switch mode (B Gain Up R Gain Up)

6. 2nd Video Output

# 1/3" DSP COLOR VARI-FOCAL DOME CAMERA

## 1. Decoration Ring

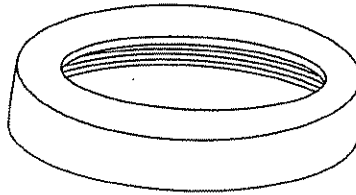

The ring is assembled and protected the glass and housing base

## 2. Polycarbonate Housing Dome

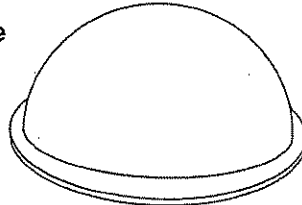

The Polycarbonate glass (pellucid and smoked type) housing dome has the function of hi-impacted vandal proof. Please fix the dome cover on the base by cover decoration ring

## 3. Cover of polycarbonate glass

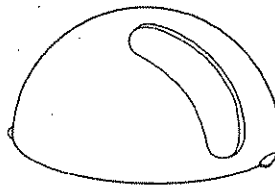

The cover of polycarbonate glass is fixed the angles of CCD camera

## 4. 3 Axis (X-Y-Z) holder

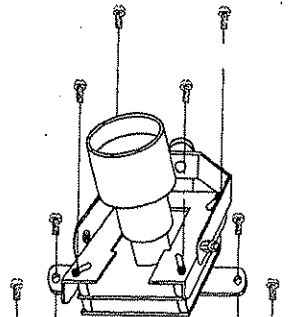

3Axis(X-Y-Z) PAN-Tilt-Twisting camera holder provides New Angles to Vari-focal dome camera. The 3Axis PTT holder enables versatile X-Y-Z positioning of various CCD board module cameras—even to capture surveillance from straight along walls and corridors

## 5. Housing Base

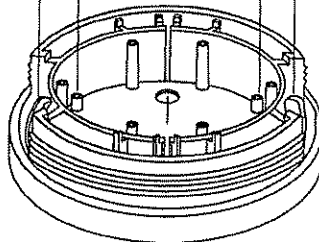

We provide the female BNC video and terminal block power adaptor connector cables  
The 2 big screw holes of side the housing base may install to the ceiling and corridors with functionality & ease for installation

### Caution

**RISK OF ELECTRICAL SHOCK ! DO NOT OPEN!**

### SAFETY CONSIDERATIONS:

Don't touch the CCD Chip with your fingers  
Use the camera only with the correct power supply which the manufacturer is required  
Use a monitor with 75 ohm impedance

### INSTALLATION STEPS:

- 1) Mount the camera securely
- 2) Connect video using suitable coaxial cable with BNC-connector
- 3) Connect the camera to a correct power supply which the manufacturer is required

*Do not attempt to disassemble the camera.*

*To prevent electric shock, do not remove screws or cover. There are no user-serviceable parts inside. Refer servicing to qualified service personnel*

*Handle the camera with care*

*Do not abuse the camera. Avoid striking or shaking it. The camera could be damaged by improper handling or storage  
Do not expose the camera to rain or moisture, or try to operate it in wet areas*

*Take immediate action if ever the camera does become wet  
Turn power off and refer servicing to qualified service personnel  
Moisture can damage the camera and also create the danger of electric shock*

*Never face the camera toward the sun*

*Whether the camera is in use or not, never face it toward the sun. Use caution when operating the camera in the vicinity of spot lights or other blight lights and light reflecting objects*

# Function Key

## Vari-Focal Lens

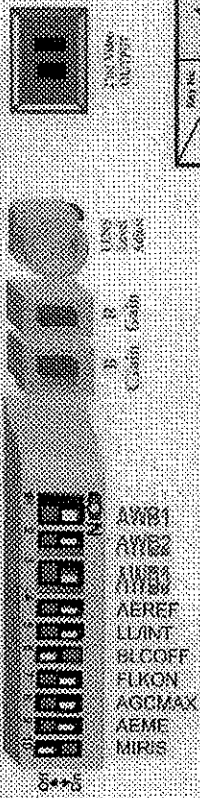

AWB1	AWB2	AWB3
ON	ON	ON
OFF	OFF	OFF
ON	ON	ON
OFF	OFF	OFF
ON	ON	ON
OFF	OFF	OFF
ON	ON	ON
OFF	OFF	OFF
ON	ON	ON
OFF	OFF	OFF

\* The "Blue Gain UP" key shifts to the high color temperature side and the "Red Gain UP" key shifts to the low color temperature side.

\* ATW: Auto White Balance  
\* AWB: Auto White Balance

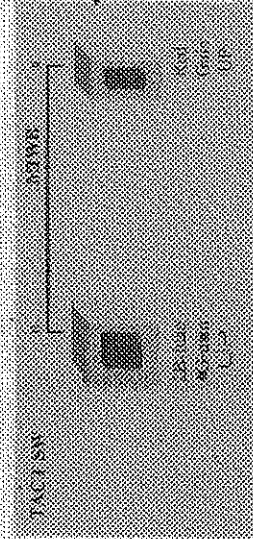

Function Key

1/2

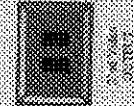
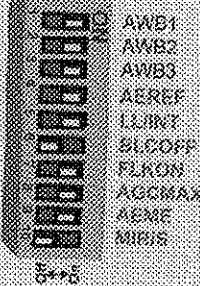

\* Filter speed search  
\* AE: Automatic Exposure Shutter Speed  
\* AE: Manual Exposure Shutter Speed

\* Lens speed  
\* BLC: Back Lens Compensation  
\* Lens speed  
\* B-REF: Electronic Shutter Speed  
\* B-REF: Manual Shutter Speed  
\* Lens speed  
\* AEREF: Automatic Exposure Shutter Speed  
\* LL/INT: Shutter Speed  
\* AGCMAX: Automatic Gain Control

Key No.	9	7	6	10	4	8	5
OFF	SHUT	FL/SH	BLCOFF	MIRIS	AEREF	AGCMAX	LL/INT
ON	AE/SH	FL/SH	BLCOFF	SHUT	AE/REF	AGCMAX	LL/INT
ON	AE/SH	FL/SH	BLCOFF	SHUT	AE/REF	AGCMAX	LL/INT
ON	AE/SH	FL/SH	BLCOFF	SHUT	AE/REF	AGCMAX	LL/INT
ON	AE/SH	FL/SH	BLCOFF	SHUT	AE/REF	AGCMAX	LL/INT
ON	AE/SH	FL/SH	BLCOFF	SHUT	AE/REF	AGCMAX	LL/INT
ON	AE/SH	FL/SH	BLCOFF	SHUT	AE/REF	AGCMAX	LL/INT
ON	AE/SH	FL/SH	BLCOFF	SHUT	AE/REF	AGCMAX	LL/INT
ON	AE/SH	FL/SH	BLCOFF	SHUT	AE/REF	AGCMAX	LL/INT
ON	AE/SH	FL/SH	BLCOFF	SHUT	AE/REF	AGCMAX	LL/INT

# Location (Factory Setting Mod)

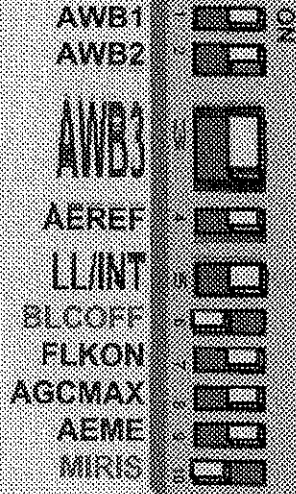

\* B Gain  
\* R Gain  
\* Lens Adjust

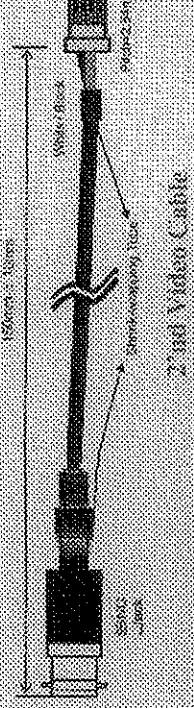

Function Key

3/3

# DCR441UL

## 4 CAMERA 12VDC POWER SUPPLY

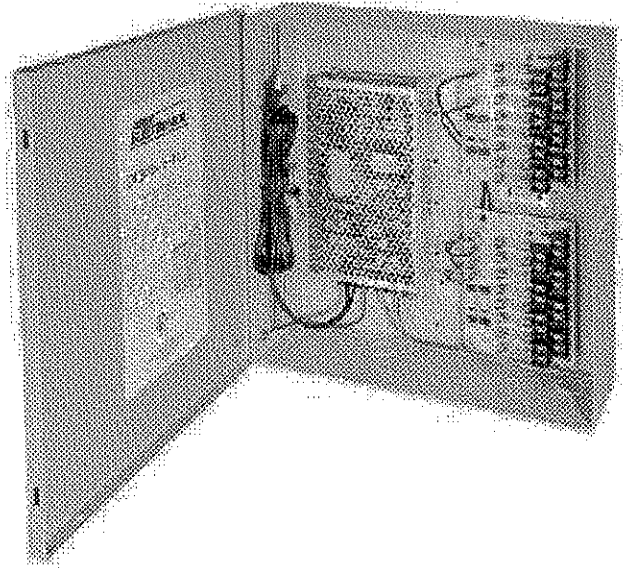

### PRODUCT FEATURES

- PTC PROTECTED
- REMOVEABLE GLASS FUSES
- MEETS CLASS 2 REQUIREMENTS
- UL LISTED

### SPECIFICATIONS

AMPERAGE	4 AMP
MAX CURRENT/CHANNEL	1500mA

ACCESSORIES/PROBLEM SOLVERS

ARM Electronics  
8860 Industrial Avenue, Suite 140 \* Roseville CA 95678  
Toll Free: 888.771.4544 \* Phone: 916.787.1100  
www.armelectronics.com \* sales@armelectronics.com





# DCR841UL

## 8 CAMERA 12VDC POWER SUPPLY

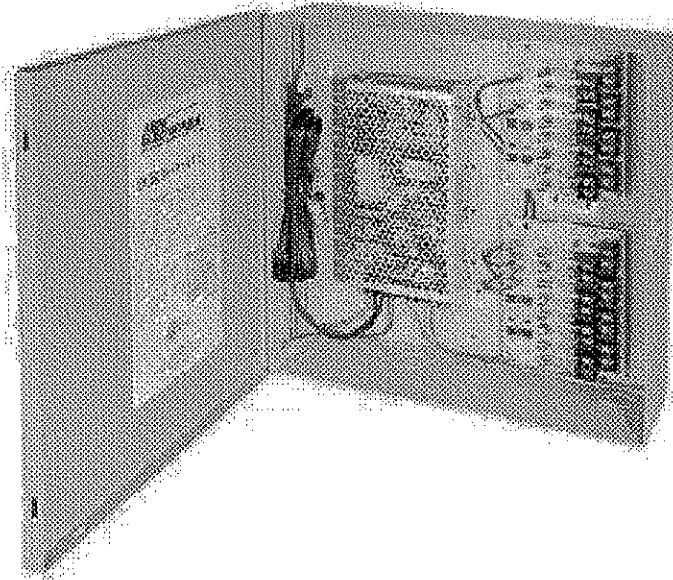

### PRODUCT FEATURES

- PTC PROTECTED
- REMOVEABLE GLASS FUSES
- MEETS CLASS 2 REQUIREMENTS
- UL LISTED

### SPECIFICATIONS

AMPERAGE 4 AMP

MAX CURRENT/CHANNEL 1500mA

ACCESSORIES/PROBLEM SOLVERS

ARM Electronics  
8860 Industrial Avenue, Suite 140 • Roseville CA 95678  
Toll Free: 888.771.4544 • Phone: 916.787.1100  
www.armelectronics.com • sales@armelectronics.com

**ARM**  
**ELECTRONICS**

# DCR1681UL

## 16 CAMERA 12VDC POWER SUPPLY

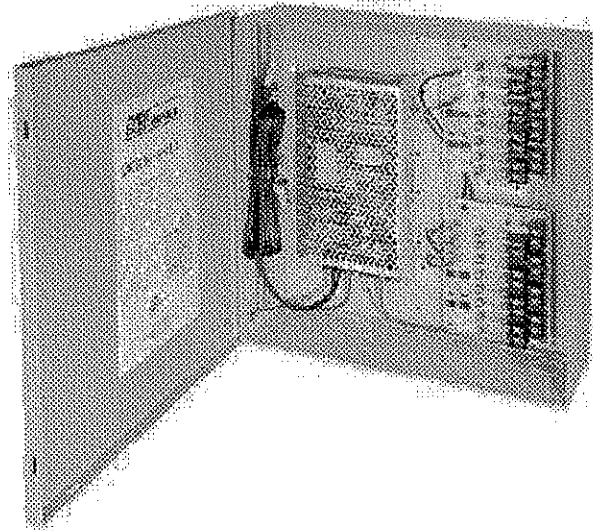

### PRODUCT FEATURES

- PTC PROTECTED
- REMOVEABLE GLASS FUSES
- MEETS CLASS 2 REQUIREMENTS
- UL LISTED

### SPECIFICATIONS

AMPERAGE ..... 3 AMP

MAX CURRENT/CHANNEL 1500mA

ACCESSORIES/PROBLEM SOLVERS

ARM Electronics  
8860 Industrial Avenue, Suite 140 • Roseville CA 95678  
Toll Free: 866.771.4544 • Phone: 916.787.1100  
www.armelectronics.com • sales@armelectronics.com

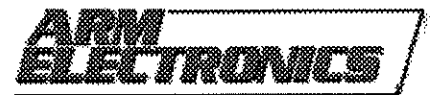

# Colour/Monochrome DSP Vari-focal Zoom Camera

ITEM NO.: C520BCDNVFIR

## FEATURES

- 1/4" SUPER HAD
- Vari-focal lens: 2.8mm~11mm
- Resolution 520 TV lines
- Auto gain control (AGC)
- Auto white balance
- Auto switch on while under 2 Lux by Photo Conductor (CDS)
- Build-in high illumination infrared LED's up range to 15~20m
- DC 12V operation
- Indoor and outdoor use, IP65 waterproof metal finger type
- Adjustable sun/weather shield

## OVERVIEW

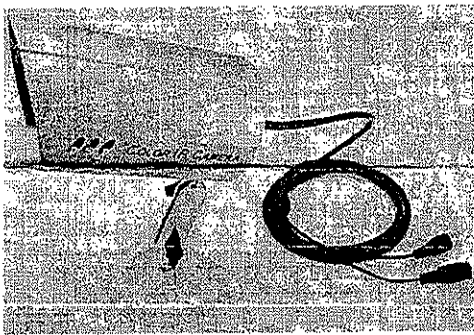

fig. 1

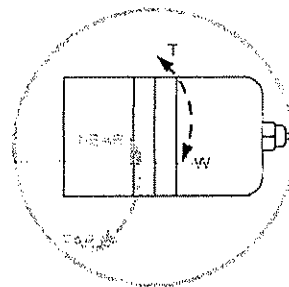
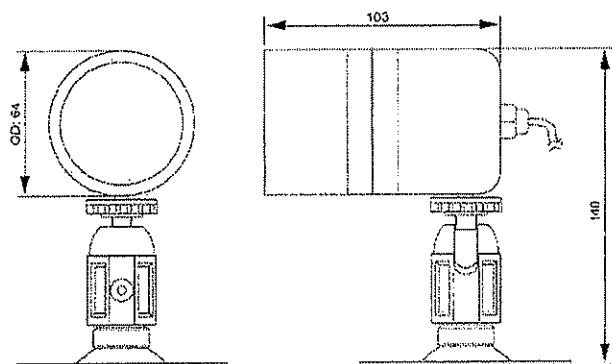
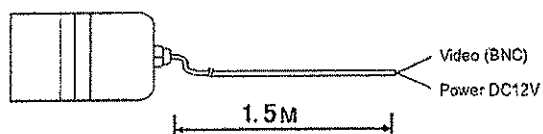

fig. 2



## INSTALLATION

1. Use the screws to fix the bracket on the wall.
2. Connect BNC connector to the video output of camera.
3. Connect DC Jack to the power of DC12V.
4. Use the bracket to connect camera.
5. Adjust the view of camera.(see fig.2. Turn the **W~T** ring to set the focal then turn the  $\infty$  ~ **N** ring to set the focus.)

### Caution for Installation

1. Avoid places where there is direct sunlight.
2. Do not directly touch the CCD element. If necessary, use a soft cloth moistened with alcohol to wipe off the dust.
3. Avoid places where temperatures exceed 45° C or more.
4. Avoid places where there is frequent vibrations or shocks.
5. Please input power regulator DC 12V.
6. When any abnormalities occur, make sure to unplug the unit and contact your local dealer.

### PACKING

- |                    |    |
|--------------------|----|
| 1. Camera          | x1 |
| 2. Bracket         | x1 |
| 3. User Manual     | x1 |
| 4. Bracket Sticker | x1 |
| 5. Accessories     | x1 |

### SPECIFICATION

ITEMS	C520BCDVFIR
TYPE	COLOUR / Mono
PICK UP DEVICE	1/4" CCD IMAGE SENSOR
PICTURE ELEMENTS	NTSC: 771H x 492 V PAL: 753 H x 582 V
HORIZONTAL RESOLUTION	520 Lines
MINI ILLUMINATION	0 lux with 21 IR LED's
VERTICAL FREQUENCY	NTSC: 60 Hz PAL: 50 Hz
SCANNING SYSTEM	2:1 INTERLACE
S/N RATIO	50 dB
ELECTRONIC SHUTTER	NTSC: 1/60~1/100,000 sec. PAL: 1/50~1/100,000 sec.
LENS	2.8~11 mm
VIDEO OUTPUT	1 Vp-p, 75 Ohms
GAMMA	0.45
DIMENSIONS W×H×D mm	φ64× 103 (w/o bracket)
WEIGHT g.	550g
POWER SUPPLY	DC 12V
POWER CONSUMPTION	IR LED OFF: 90mA IR LED ON: 210mA
STORAGE TEMPERATURE	- 30 ~ + 60°C
OPERATING TEMPERATURE	- 10 ~ + 45°C

TAIWAN PETENT: M 265622,2005~2014

CHINA PETENT: ZL200520018296.6,2005~2014



THIS DEVICE COMPLIES WITH PART 15 OF THE FCC RULES. OPERATION IS SUBJECT TO THE FOLLOWING TWO CONDITIONS: (1) THIS DEVICE MUST NOT CAUSE HARMFUL INTERFERENCE AND (2) THIS DEVICE MUST ACCEPT ANY INTERFERENCE RECEIVED INCLUDING INTERFERENCE THAT MAY CAUSE UNDESIRABLE OPERATION.

C520BCDVFIR 20070914