



State of West Virginia
 Department of Administration
 Purchasing Division
 2019 Washington Street East
 Post Office Box 50130
 Charleston, WV 25305-0130

**Request for
 Quotation**

RFQ NUMBER
 DEP14150

PAGE
 1

ADDRESS CORRESPONDENCE TO ATTENTION OF
 CHUCK BOWMAN
 304-558-2157

VENDOR

**RFQ COPY
 TYPE NAME/ADDRESS HERE**
 Service Supply & Supply, Inc.
 P.O. Box 2097
 Huntington, WV 25721

SHIP TO

**ENVIRONMENTAL PROTECTION
 DEPT. OF
 OFFICE OF SPECIAL RECLAMATION
 105 S. RAILROAD STREET
 PHILIPPI, WV
 26416-9998 304-457-3219**

DATE PRINTED	TERMS OF SALE	SHIP VIA	F.O.B.	FREIGHT TERMS
10/30/2008				

BID OPENING DATE: **11/18/2008** BID OPENING TIME **01:30PM**

LINE	QUANTITY	UOP	CAT NO	ITEM NUMBER	UNIT PRICE	AMOUNT
0001		EA		968-72		
<p>RECEIVED</p> <p>2008 NOV 18 A 10:46</p> <p>PURCHASING DIVISION STATE OF WV</p>						
<p>THE WEST VIRGINIA PURCHASING DIVISION, FOR THE AGENCY, THE WEST VIRGINIA DEPARTMENT OF ENVIRONMENTAL PROTECTION'S OFFICE OF SPECIAL RECLAMATION, IS SOLICITING BIDS FROM QUALIFIED CONTRACTORS TO PROVIDE ALL MATERIALS, LABOR AND APPROPRIATE EQUIPMENT TO CONDUCT SNOW REMOVAL FOR WINTER ACCESS TO VARIOUS SITES AND PUMPING SERVICES TO INCLUDE ACID MINE DRAINAGE SLUDGE AT VARIOUS SPECIAL RECLAMATION PROJECT SITES IN NORTHERN WEST VIRGINIA, PER THE FOLLOWING SPECIFICATIONS, BID REQUIREMENTS, SCOPE OF WORK, AND TERMS AND CONDITIONS CONTAINED HERE IN.</p> <p>EXHIBIT 3</p> <p>LIFE OF CONTRACT: THIS CONTRACT BECOMES EFFECTIVE UPON AWARD AND EXTENDS FOR A PERIOD OF ONE (1) YEAR OR UNTIL SUCH "REASONABLE TIME" THEREAFTER AS IS NECESSARY TO OBTAIN A NEW CONTRACT OR RENEW THE ORIGINAL CONTRACT. THE "REASONABLE TIME" PERIOD SHALL NOT EXCEED TWELVE (12) MONTHS. DURING THIS "REASONABLE TIME" THE VENDOR MAY TERMINATE THIS CONTRACT FOR ANY REASON UPON GIVING THE DIRECTOR OF PURCHASING 30 DAYS WRITTEN NOTICE.</p> <p>UNLESS SPECIFIC PROVISIONS ARE STIPULATED ELSEWHERE IN THIS CONTRACT DOCUMENT, THE TERMS, CONDITIONS AND PRICING SET HEREIN ARE FIRM FOR THE LIFE OF THE</p>						

SEE REVERSE SIDE FOR TERMS AND CONDITIONS

SIGNATURE <i>Ray Redman</i>	TELEPHONE (304)-429-6731	DATE 11-18-08
TITLE <i>Sales</i>	FEIN 55-0599012	ADDRESS CHANGES TO BE NOTED ABOVE

WHEN RESPONDING TO RFQ, INSERT NAME AND ADDRESS IN SPACE ABOVE LABELED 'VENDOR'



State of West Virginia
 Department of Administration
 Purchasing Division
 2019 Washington Street East
 Post Office Box 50130
 Charleston, WV 25305-0130

**Request for
 Quotation**

RFQ NUMBER
DEP14150

PAGE
2

ADDRESS CORRESPONDENCE TO ATTENTION OF:
**CHUCK BOWMAN
 304-558-2157**

VENDOR

**RFQ COPY
 TYPE NAME/ADDRESS HERE**

Service Pump & Supply, Inc.
 P.O. Box 2097
 Huntington, WV 25721

SHIP TO

**ENVIRONMENTAL PROTECTION
 DEPT. OF
 OFFICE OF SPECIAL RECLAMATION
 105 S. RAILROAD STREET
 PHILIPPI, WV
 26416-9998 304-457-3219**

DATE PRINTED 10/30/2008	TERMS OF SALE	SHIP VIA	F.O.B.	FREIGHT TERMS
-----------------------------------	---------------	----------	--------	---------------

BID OPENING DATE: **11/18/2008** BID OPENING TIME **01:30PM**

LINE	QUANTITY	UQP	CAT NO	ITEM NUMBER	UNIT PRICE	AMOUNT
<p>CONTRACT.</p> <p>RENEWAL: THIS CONTRACT MAY BE RENEWED UPON THE MUTUAL WRITTEN CONSENT OF THE SPENDING UNIT AND VENDOR, SUBMITTED TO THE DIRECTOR OF PURCHASING THIRTY (30) DAYS PRIOR TO THE EXPIRATION DATE. SUCH RENEWAL SHALL BE IN ACCORDANCE WITH THE TERMS AND CONDITIONS OF THE ORIGINAL CONTRACT AND SHALL BE LIMITED TO TWO (2) ONE (1) YEAR PERIODS.</p> <p>CANCELLATION: THE DIRECTOR OF PURCHASING RESERVES THE RIGHT TO CANCEL THIS CONTRACT IMMEDIATELY UPON WRITTEN NOTICE TO THE VENDOR IF THE COMMODITIES AND/OR SERVICES SUPPLIED ARE OF AN INFERIOR QUALITY OR DO NOT CONFORM TO THE SPECIFICATIONS OF THE BID AND CONTRACT HEREIN.</p> <p>OPEN MARKET CLAUSE: THE DIRECTOR OF PURCHASING MAY AUTHORIZE A SPENDING UNIT TO PURCHASE ON THE OPEN MARKET, WITHOUT THE FILING OF A REQUISITION OR COST ESTIMATE, ITEMS SPECIFIED ON THIS CONTRACT FOR IMMEDIATE DELIVERY IN EMERGENCIES DUE TO UNFORESEEN CAUSES (INCLUDING BUT NOT LIMITED TO DELAYS IN TRANSPORTATION OR AN UNANTICIPATED INCREASE IN THE VOLUME OF WORK.)</p> <p>QUANTITIES: QUANTITIES LISTED IN THE REQUISITION ARE APPROXIMATIONS ONLY, BASED ON ESTIMATES SUPPLIED BY THE STATE SPENDING UNIT. IT IS UNDERSTOOD AND AGREED THAT THE CONTRACT SHALL COVER THE QUANTITIES ACTUALLY ORDERED FOR DELIVERY DURING THE TERM OF THE CONTRACT, WHETHER MORE OR LESS THAN THE QUANTITIES SHOWN.</p> <p>ORDERING PROCEDURE: SPENDING UNIT(S) SHALL ISSUE A WRITTEN STATE CONTRACT ORDER (FORM NUMBER WV-39) TO THE VENDOR FOR COMMODITIES COVERED BY THIS CONTRACT. THE ORIGINAL COPY OF THE WV-39 SHALL BE MAILED TO THE</p>						

SEE REVERSE SIDE FOR TERMS AND CONDITIONS

SIGNATURE <i>Ray Kellum</i>	TELEPHONE (304)-429-6731	DATE 11-18-08
TITLE <i>Secy</i>	FEIN 55-0599012	ADDRESS CHANGES TO BE NOTED ABOVE

WHEN RESPONDING TO RFQ, INSERT NAME AND ADDRESS IN SPACE ABOVE LABELED 'VENDOR'



State of West Virginia
 Department of Administration
 Purchasing Division
 2019 Washington Street East
 Post Office Box 50130
 Charleston, WV 25305-0130

Request for Quotation

RFQ NUMBER
DEP14150

PAGE
3

ADDRESS CORRESPONDENCE TO ATTENTION OF
**CHUCK BOWMAN
 304-558-2157**

**RFQ COPY
 TYPE NAME/ADDRESS HERE**

Service Pump & Supply, Inc.
 P.O. Box 2097
 Huntington, WV 25721

**ENVIRONMENTAL PROTECTION
 DEPT. OF
 OFFICE OF SPECIAL RECLAMATION
 105 S. RAILROAD STREET
 PHILIPPI, WV
 26416-9998 304-457-3219**

DATE PRINTED	TERMS OF SALE	SHIP VIA	F.O.B.	FREIGHT TERMS
10/30/2008				

BID OPENING DATE: **11/18/2008** BID OPENING TIME **01:30PM**

LINE	QUANTITY	UCP	CAT NO	ITEM NUMBER	UNIT PRICE	AMOUNT
<p>VENDOR AS AUTHORIZATION FOR SHIPMENT, A SECOND COPY MAILED TO THE PURCHASING DIVISION, AND A THIRD COPY RETAINED BY THE SPENDING UNIT.</p> <p>REV. 3/88</p> <p>BANKRUPTCY: IN THE EVENT THE VENDOR/CONTRACTOR FILES FOR BANKRUPTCY PROTECTION, THIS CONTRACT IS AUTOMATICALLY NULL AND VOID, AND IS TERMINATED WITHOUT FURTHER ORDER.</p> <p>WAGE RATES: THE CONTRACTOR OR SUBCONTRACTOR SHALL PAY THE HIGHER OF THE U.S. DEPARTMENT OF LABOR MINIMUM WAGE RATES AS ESTABLISHED FOR NORTHERN COUNTIES, PURSUANT TO WEST VIRGINIA CODE 21-5-1, ET, SEQ. (PREVAILING WAGE RATES APPLY TO THIS PROJECT)</p> <p>WORKERS' COMPENSATION: VENDOR IS REQUIRED TO PROVIDE A CERTIFICATE FROM WORKERS' COMPENSATION IF SUCCESSFUL.</p> <p>INSURANCE: SUCCESSFUL VENDOR SHALL FURNISH PROOF OF COMMERCIAL GENERAL LIABILITY INSURANCE PRIOR TO ISSUANCE OF CONTRACT. UNLESS OTHERWISE SPECIFIED IN THE BID DOCUMENTS, THE MINIMUM AMOUNT OF INSURANCE COVERAGE REQUIRED IS \$250,000.</p> <p>AUTOMOBILE LIABILITY: VENDOR SHALL PROVIDE PROOF OF AUTO LIABILITY INSURANCE. AUTO LIABILITY INSURANCE SHALL HAVE BODILY INJURY LIMITS OF NOT LESS THAN THREE HUNDRED THOUSAND DOLLARS (U.S. \$300,000.00) PER OCCURRENCE AND PROPERTY DAMAGE LIMITS OF NOT LESS THAN ONE HUNDRED THOUSAND DOLLARS (U.S. \$100,000.00)</p> <p style="text-align: center;">NOTICE</p>						

SEE REVERSE SIDE FOR TERMS AND CONDITIONS

SIGNATURE <i>Ray Kellum</i>	TELEPHONE (304)-429-6731	DATE 11-18-08
TITLE <i>Solo</i>	FEIN 55-0599012	ADDRESS CHANGES TO BE NOTED ABOVE

WHEN RESPONDING TO RFQ, INSERT NAME AND ADDRESS IN SPACE ABOVE LABELED 'VENDOR'



State of West Virginia
 Department of Administration
 Purchasing Division
 2019 Washington Street East
 Post Office Box 50130
 Charleston, WV 25305-0130

Request for Quotation

RFQ NUMBER
 DEP14150

PAGE
 4

ADDRESS CORRESPONDENCE TO ATTENTION OF
 CHUCK BOWMAN
 304-558-2157

RFQ COPY
TYPE NAME/ADDRESS HERE

Service Pump & Supply, Inc.
 P.O. Box 2097
 Huntington, WV 25721

ENVIRONMENTAL PROTECTION
DEPT. OF
OFFICE OF SPECIAL RECLAMATION
105 S. RAILROAD STREET
PHILIPPI, WV
26416-9998 304-457-3219

DATE PRINTED	TERMS OF SALE	SHIP VIA	FOB	FREIGHT TERMS
10/30/2008				

BID OPENING DATE: **11/18/2008** BID OPENING TIME **01:30PM**

LINE	QUANTITY	UOP	CAT. NO.	ITEM NUMBER	UNIT PRICE	AMOUNT
<p>A SIGNED BID MUST BE SUBMITTED TO:</p> <p>DEPARTMENT OF ADMINISTRATION PURCHASING DIVISION BUILDING 15 2019 WASHINGTON STREET, EAST CHARLESTON, WV 25305-0130</p> <p>THE BID SHOULD CONTAIN THIS INFORMATION ON THE FACE OF THE ENVELOPE OR THE BID MAY NOT BE CONSIDERED:</p> <p>SEALED BID</p> <p>BUYER: CB-23</p> <p>RFQ. NO.: DEP14150</p> <p>BID OPENING DATE: 11/18/2008</p> <p>BID OPENING TIME: 1:30 PM</p> <p>PLEASE PROVIDE A FAX NUMBER IN CASE IT IS NECESSARY TO CONTACT YOU REGARDING YOUR BID: ----- 304-429-6736 -----</p> <p>CONTACT PERSON (PLEASE PRINT CLEARLY): ----- Ray Redman -----</p>						

SEE REVERSE SIDE FOR TERMS AND CONDITIONS

SIGNATURE	TELEPHONE (304) 429-6731	DATE 11-18-08
TITLE	FBN 55-0599012	ADDRESS CHANGES TO BE NOTED ABOVE

WHEN RESPONDING TO RFQ, INSERT NAME AND ADDRESS IN SPACE ABOVE LABELED 'VENDOR'

BUYER CB-23	PAGE 005	REQ. OR PO NO. DEP 14150
SPENDING UNIT WEST VIRGINIA DEPARTMENT OF ENVIRONMENTAL PROTECTION/SPECIAL RECLAMATION		

WV-36 STATE OF WEST VIRGINIA
REV. 5-1-08 PURCHASING CONTINUATION SHEET
VENDOR:

SCOPE OF WORK

The successful bidder shall provide appropriate equipment, materials, labor and any technical services needed for the scope of work as described in this contract. The General Performance Standards (GPS) shall apply to all items in Scope of Work.

Sludge pumping will be from treated acid mine drainage settling ponds through 6 inch diameter high density polyethylene piping, which has been permanently installed beside the pond to sludge drying cells. The sludge pipe connections are fitted with cam and groove adaptors for quick connection to a pump. Most sludge drying cells are 120 feet or less in height above the treatment settling ponds (ponds require approximately 20 feet of suction lift). Some treatment sites require two 6 inch sludge pumps in series or use of a high-head pump due to pumping heights greater than 120 feet. The pumping distance varies from site to site, but is normally less than 1000 feet. All pumps shall be in good operable condition and be readily available to be used at as many as four different locations at any given time. Some sludge removal sites will require continuous pumping from start-up to finish. Any trailer-mounted pumps specified shall meet Department of Transportation (DOT) approval for highway travel.

Snow removal shall be provided for winter access on gravel-based compacted access roads that lead to treatment sites. The DEP staff, as well as the contractor, needs winter access to these sites for sludge pumping. The access road lengths vary from site to site, and may be 0.5 to 2.0 miles on average, however some sites may be more.

CONTRACTUAL INFORMATION & REQUIREMENTS

Location of Work-North

The area of work shall include the Northern Counties of West Virginia. The counties listed below are the coal producing counties and those in parenthesis represent where most of the work required in this contract is located.

- | | |
|-----------------|----------------|
| 1. Hancock | 15. (Tucker) |
| 2. Brooke | 16. Barbour |
| 3. Ohio | 17. Lewis |
| 4. Marshall | 18. Braxton |
| 5. Wetzel | 19. (Upshur) |
| 6. Tyler | 20. Pocahontas |
| 7. (Monongalia) | 21. Randolph |
| 8. (Preston) | 22. Pendleton |
| 9. Marion | 23. Gilmer |
| 10. Doddridge | 24. Webster |
| 11. Harrison | 25. Pleasants |
| 12. Taylor | 26. Wood |
| 13. (Mineral) | 27. Ritchie |
| 14. (Grant) | |

BUYER CB-23	PAGE 006	REQ. OR PO NO. DEP 14150
SPENDING UNIT WEST VIRGINIA DEPARTMENT OF ENVIRONMENTAL PROTECTION/SPECIAL RECLAMATION		

WV-36 STATE OF WEST VIRGINIA
REV. 5-1-08 PURCHASING CONTINUATION SHEET
VENDOR:

Definitions

- A. The words "Owner", "The State", "DEP" or "Office of Special Reclamation" are used herein to refer to the West Virginia Department of Environmental Protection, Office of Special Reclamation.
- B. The word "offeror" refers to the person or company offering to furnish the services called for in this request for proposal.
- C. The word "Contract" is used to refer to the agreement or purchase order requested by the owner and accepted by the contractor together with all the provisions of this request for proposal and all parts of said agreement of purchase order.
- D. The word "Contractor" refers to the person or company contracting with State to furnish the "services" called for by the contract.
- E. The words "services" or "work" is used to mean and include all labor, supervision, materials, machinery, equipment, tools, supplies, and facilities called for in the work directives issued within the contract.
- F. The word "Director" is used to mean the Director of the Division of Land Restoration, Department of Environmental Protection, and shall be considered to be the State's authorized representative.

Ordering Procedure

- A. This is an open end quantity contract for the services specified in the statement of work and for the period set forth herein. Delivery or performance shall be made in accordance with the provisions of this contract.
- B. Work will be ordered by the Director or his representative, for the Office of Special Reclamation, West Virginia Department of Environmental Protection by issuance of a work directive, which shall include the name of the project site, and the cost estimate (quantity of work to be done). The contractor shall acknowledge receipt by signing, dating and forwarding back to the Director the cost estimate for the work requested. The cost estimate shall be in accordance with the unit prices provided in the response to this proposal. No work shall be performed until a notice to proceed has been issued by the State.

Delivery

- A. The contractor shall complete the specified maintenance work in accordance to each work directive. The contractor shall give an invoice to the Department of Environmental Protection representative upon completion of each pumping session or work directive.

BUYER CB-23	PAGE 007	REQ. OR PO NO. DEP 14150
SPENDING UNIT WEST VIRGINIA DEPARTMENT OF ENVIRONMENTAL PROTECTION/SPECIAL RECLAMATION		

WV-36 STATE OF WEST VIRGINIA
REV. 5-1-08 PURCHASING CONTINUATION SHEET
VENDOR:

- B. Inspections of each project will be made by the Director or his authorized representative as the work progresses and at completion. A final inspection will be made when all work is completed.
- C. Acceptance criteria will be based on all work being completed as requested in the work directive.

General Conditions

- A. The contractor shall be responsible for paying and/or securing all taxes, permits, fees, insurance liability, compensations, and any other items necessary to render the owner free and harmless from all claims arising from services performed under this contract.
- B. The contractor shall take steps required to ensure equal opportunity for employment in accordance with policies promulgated by the Presidents Committee on Equal Opportunity.
- C. The State shall be responsible for obtaining all rights of entry for each project, if needed.
- D. The work and services to be performed under this contract shall be subject to continual monitoring and inspection by the State's authorized representative. Such inspection will, among other things, ensure technical compliance.
- E. In accomplishment of services to fulfill the requirements of the work directive, neither contractor nor his subcontractor shall create any adverse environmental effects and shall be responsible for compliance with all applicable local, state, and federal environmental and occupational health and safety regulations pertinent to the work.

Costs and Payments

- A. Payment to the contractor will be made on the following basis:
 - 1. Unit Pricing
 - Item - As directed by the State in specific work directive.
 - Quantity - As agreed to prior to issuing a Notice to Proceed.
 - Unit Price - As provided by the Offeror in the proposal.
- B. The contractor shall invoice on specified DEP forms to the department after completion of work specified in the work directive; final inspection has been made; and the work is accepted by the department. All invoices shall show the quantities and unit prices approved in the cost estimate for the work directive.
Multiple invoices will be accepted on Work Directives with prior approval of the DEP.

BUYER CB-23	PAGE 008	REQ. OR PO NO. DEP 14150
SPENDING UNIT WEST VIRGINIA DEPARTMENT OF ENVIRONMENTAL PROTECTION/SPECIAL RECLAMATION		

WV-36 STATE OF WEST VIRGINIA
REV. 5-1-08 PURCHASING CONTINUATION SHEET
VENDOR:

Changes in the Contract

A. The State, without invalidating the contract, may order changes in the work within the general scope of the contract consisting of additions, deletions, or other revisions. All such changes in the work shall be authorized by a change order. A change order signed by both the State and Offeror indicates their agreement to an adjustment to the contract. The cost or credit to the State resulting from a change in the work shall be determined in one or more of the following ways:

- 1) By mutual acceptance of a lump sum properly documented (itemized)
- 2) By unit prices (negotiated)

All materials must have approval from a DEP representative.

BUYER CB-23	PAGE 009	REQ. OR PO NO. DEP 14150
SPENDING UNIT WEST VIRGINIA DEPARTMENT OF ENVIRONMENTAL PROTECTION/SPECIAL RECLAMATION		

WV-36 STATE OF WEST VIRGINIA
REV. 5-1-08 PURCHASING CONTINUATION SHEET
VENDOR:

BID ITEM TECHNICAL SPECIFICATIONS

1.0 MOBILIZATION/DEMobilIZATION

Payment shall be made for mobilization and/or demobilization of each 6 inch Trash Pump to and from the sludge pumping sites as defined in the Work Directives. This bid item shall also be utilized for mobilization and demobilization for each snow plow truck to and from the treatment sites as defined in the Work Directives. If multiple sites are to be consecutively pumped or plowed, the mobilization will only be paid from site to site after reaching the first site. Demobilization shall be paid when leaving the last site.

Method of Payment: Payment shall be based on an Hourly Rate unit price. The maximum bid amount shall be \$60/Hour.

2.0 SETUP AND DISMANTLE OF 6 INCH PUMPS

Payment shall be made for setup and dismantle of each 6 inch Trash Pump at a sludge pumping site. Any persons involved in the setup and dismantle of pumps, not including the pump operator, shall be incidental to this bid item. Pump personnel shall be included with each pump specified for a site by a DEP representative. Any adjustments to the suction and discharge lines after the initial pump setup at a pumping site shall not be considered a separate event.

Method of Payment: Payment shall be lump sum unit price for each actual setup or relocation of the pump. The maximum lump sum bid amount shall be \$300/EA.

3.0 TRASH PUMP(S) 6 INCH DIAMETER gas a/o diesel powered with trailer mounting

These pumps shall be used for the actual sludge pumping from the treatment ponds to sludge drying cells. Provide Godwin brand self-priming centrifugal 6 inch x 6 inch size pump model #CD150M (or approved equal). Minimum pump specifications include: Solids handling type pumps of up to 3 inch diameter spherical solids; Dry running capability; Capable of pumping 800 gpm at 140 feet Total Dynamic Head (TDH); Operate at the pump motor's rated maximum continuous performance (see the pump manufacturer performance curve) for the duration of pumping on site to obtain maximum pumping efficiency.

If a larger pump is utilized than the one specified, it shall be the contractor's responsibility to verify that the pumping rate is equal or greater than described above.

A minimum of 100 feet of suction hose shall be provided with each pump. A minimum of 150 feet of discharge hose shall be provided with each pump. A minimum of three pumps shall be available for use at multiple pumping locations in the northern area. Also, two pumps may be used in series at one time at a treatment site. All personnel necessary to efficiently and effectively operate the pump(s) shall be included with this bid item unit price. A bolt on type float shall be available for each pump suction line, and at the DEP representative's request, the float may be required to maintain the suction line off of the bottom of the pond. The float may need to be adjusted for each pond, or as a pond is pumped.

Pump Operator(s) Responsibilities: The operator(s) shall be responsible for cleaning of any suction strainer heads on the suction lines; installing and adjusting floats on the suction lines to maintain a mixture of heavy sludge and water; moving or making adjustments to the location of suction line while pumping by use of ropes attached to the suction line. The pump operator(s) shall be responsible to insure that the pump is operated at maximum efficiency.

Method of Payment: Payment shall be based on an Hourly Rate (actual hours of pump use).

BUYER CB-23	PAGE 010	REQ. OR PO NO. DEP 14150
SPENDING UNIT WEST VIRGINIA DEPARTMENT OF ENVIRONMENTAL PROTECTION/SPECIAL RECLAMATION		

WV-36 STATE OF WEST VIRGINIA
REV. 5-1-08 PURCHASING CONTINUATION SHEET
VENDOR:

4.0 HIGH HEAD TRASH PUMP 6 INCH DIAMETER gas a/o diesel powered with trailer mounting

This pump shall be used for the actual sludge pumping from the treatment ponds to sludge drying cells at higher elevations. Provide Godwin brand self-priming centrifugal 6 inch x 6 inch size pump model#CD160M (or approved equal). Minimum pump specifications include: Solids handling type pump of up to 3 inch diameter spherical solids; Dry running capability; Capable of pumping 800 gpm at 220 feet Total Dynamic Head (TDH); Operate at the pump motor's rated maximum continuous performance (see the pump manufacturer performance curve) for the duration of pumping on site to obtain maximum pumping efficiency.

If a larger pump is utilized than the one specified, it shall be the contractor's responsibility to verify that the pumping rate is equal or greater than described above.

A minimum of 100 feet of suction hose shall be provided with each pump. A minimum of 150 feet of discharge hose shall be provided with each pump. A minimum of one pump shall be available for use at multiple pumping locations in the northern area. All personnel necessary to efficiently and effectively operate the pump shall be included with this bid item unit price. A bolt on type float shall be available for each pump suction line, and at the DEP representative's request, the float may be required to maintain the suction line off of the bottom of the pond. The float may need to be adjusted for each pond, or as a pond is pumped.

Pump Operator(s) Responsibilities: The operator(s) shall be responsible for cleaning of the suction strainer head on the suction line; installing and adjusting the float on the suction line to maintain a mixture of heavy sludge and water; moving or making adjustments to the location of suction line while pumping by use of ropes attached to the suction line. The pump operator(s) shall be responsible to insure that the pump is operated at maximum efficiency.

Method of Payment: Payment shall be based on an Hourly Rate unit price (actual hours of pump use).

5.0 WATER PUMP(S) 3 INCH DIAMETER gas a/o diesel powered

This pump shall be used for certain treatment sites to circulate water in the treatment pond to move the sludge toward the 6 inch pump intake line. This process liquefies the sludge to allow for easier pumping.

A minimum of 100 feet of suction hose shall be provided with the pump. A minimum of 200 feet of discharge hose shall be provided with the pump. The discharge hose shall have an industrial duty wash down nozzle to produce a narrow stream.

Pump Operator(s) Responsibilities: The operator(s) shall be responsible for maintaining the discharge line to effectively circulate fresh water toward the section of the pond with dense sludge; use the wash down nozzle to direct a stream of water in dense sludge areas to move the sludge toward the 6 inch intake line; wash down the entrance rip rap ditches, if requested by the DEP representative.

There will be no payment for mobilization and demobilization for this pump. The setup and dismantle for this pump shall be incidental to this bid item, and there will be no separate payment. All personnel necessary to efficiently and effectively operate the pump(s) shall be included with this bid item unit price. A minimum of two pumps shall be available for use at multiple pumping locations in the northern area.

Method of Payment: Payment shall be based on an Hourly Rate unit price (actual hours of pump use).

6.0 SNOW REMOVAL

Snow removal shall be provided for winter access on gravel-based compacted access roads that lead to treatment sites. A minimum of two trucks shall be available for snow removal at multiple locations, or use of both trucks at one location. The minimum size trucks shall be one (1) ton size pickups with 8 feet wide

BUYER CB-23	PAGE 011	REQ. OR PO NO. DEP 14150
SPENDING UNIT WEST VIRGINIA DEPARTMENT OF ENVIRONMENTAL PROTECTION/SPECIAL RECLAMATION		

WV-36 STATE OF WEST VIRGINIA
REV. 5-1-08 PURCHASING CONTINUATION SHEET
VENDOR:

(minimum) snow blades. The truck and plow operator(s) shall be included with this unit price. Mobilization and demobilization to the site shall be paid with Bid Item # 1.0.

Method of Payment: Payment shall be based on an Hourly Rate unit price.

BUYER CB-23	PAGE 012	REQ. OR PO NO. DEP 14150
SPENDING UNIT WEST VIRGINIA DEPARTMENT OF ENVIRONMENTAL PROTECTION/SPECIAL RECLAMATION		

WV-36 STATE OF WEST VIRGINIA
REV. 5-1-08 PURCHASING CONTINUATION SHEET
VENDOR:

BID SCHEDULE

ITEM NO.	QUANTITY	DESCRIPTION	UNIT PRICE	AMOUNT
1.0	1000 HRS	Mobilization/Demobilization (Maximum Bid Amount = \$60/HR)	\$ 60.00 PER HR	\$60,000.00
2.0	200 EA	Setup and Dismantle of 6" Pumps (Maximum Bid Amount = \$300/EA)	\$ 300 /EA	\$60,000.00
3.0	3000 HRS	Trash Pump(s) 6 inch Dia. Gas a/o DSL powered with trailer mounting <i>Thompson 6TSC</i>	\$ 126.75 PER HR	\$380,250.00
4.0	1000 HRS	High Head Trash Pump 6 inch Dia. Gas a/o DSL powered with trailer mounting <i>Thompson 6JSCD - 6068T-M</i>	\$ 134.75 PER HR	\$134,750.00
5.0	500 HRS	Water Pump(s) 3 inch Dia. Gas a/o DSL powered	\$ 12.50 PER HR	\$6250.00
6.0	500 HRS	Truck(s) with snow blade; minimum 1 ton pickup with 8-foot wide snow blade. (Personnel included)	\$ 66.00 PER HR	\$33,000.00
		TOTAL		\$674,250.00

NOTE:

- All items must be bid and bid in the unit measure specified in the quantity column.
- The quantities are applied for bidding purposes only. Actual quantities shall be based on work performed and may be more or less depending on the necessity for pumping and / or snow removal.
- Bid items #3.0, #4.0, and #5.0 unit prices shall also include all personnel necessary to effectively and efficiently operate each pump(s).
- Please review the Bid Item Technical Specifications for further details of each bid item.

State of West Virginia VENDOR PREFERENCE CERTIFICATE

Certification and application* is hereby made for Preference in accordance with *West Virginia Code*, §5A-3-37. (Does not apply to construction contracts). *West Virginia Code*, §5A-3-37, provides an opportunity for qualifying vendors to request (at the time of bid) preference for their residency status. Such preference is an evaluation method only and will be applied only to the cost bid in accordance with the *West Virginia Code*. This certificate for application is to be used to request such preference. The Purchasing Division will make the determination of the Resident Vendor Preference, if applicable.

1. **Application is made for 2.5% resident vendor preference for the reason checked:**
 Bidder is an individual resident vendor and has resided continuously in West Virginia for four (4) years immediately preceding the date of this certification; or,
 Bidder is a partnership, association or corporation resident vendor and has maintained its headquarters or principal place of business continuously in West Virginia for four (4) years immediately preceding the date of this certification; or 80% of the ownership interest of Bidder is held by another individual, partnership, association or corporation resident vendor who has maintained its headquarters or principal place of business continuously in West Virginia for four (4) years immediately preceding the date of this certification; or,
 Bidder is a nonresident vendor which has an affiliate or subsidiary which employs a minimum of one hundred state residents and which has maintained its headquarters or principal place of business within West Virginia continuously for the four (4) years immediately preceding the date of this certification; or,
2. **Application is made for 2.5% resident vendor preference for the reason checked:**
 Bidder is a resident vendor who certifies that, during the life of the contract, on average at least 75% of the employees working on the project being bid are residents of West Virginia who have resided in the state continuously for the two years immediately preceding submission of this bid; or,
3. **Application is made for 2.5% resident vendor preference for the reason checked:**
 Bidder is a nonresident vendor employing a minimum of one hundred state residents or is a nonresident vendor with an affiliate or subsidiary which maintains its headquarters or principal place of business within West Virginia employing a minimum of one hundred state residents who certifies that, during the life of the contract, on average at least 75% of the employees or Bidder's affiliate's or subsidiary's employees are residents of West Virginia who have resided in the state continuously for the two years immediately preceding submission of this bid; or,
4. **Application is made for 5% resident vendor preference for the reason checked:**
 Bidder meets either the requirement of both subdivisions (1) and (2) or subdivision (1) and (3) as stated above; or,
5. **Application is made for 3.5% resident vendor preference who is a veteran for the reason checked:**
 Bidder is an individual resident vendor who is a veteran of the United States armed forces, the reserves or the National Guard and has resided in West Virginia continuously for the four years immediately preceding the date on which the bid is submitted; or,
6. **Application is made for 3.5% resident vendor preference who is a veteran for the reason checked:**
 Bidder is a resident vendor who is a veteran of the United States armed forces, the reserves or the National Guard, if, for purposes of producing or distributing the commodities or completing the project which is the subject of the vendor's bid and continuously over the entire term of the project, on average at least seventy-five percent of the vendor's employees are residents of West Virginia who have resided in the state continuously for the two immediately preceding years.

Bidder understands if the Secretary of Revenue determines that a Bidder receiving preference has failed to continue to meet the requirements for such preference, the Secretary may order the Director of Purchasing to: (a) reject the bid; or (b) assess a penalty against such Bidder in an amount not to exceed 5% of the bid amount and that such penalty will be paid to the contracting agency or deducted from any unpaid balance on the contract or purchase order.

By submission of this certificate, Bidder agrees to disclose any reasonably requested information to the Purchasing Division and authorizes the Department of Revenue to disclose to the Director of Purchasing appropriate information verifying that Bidder has paid the required business taxes, provided that such information does not contain the amounts of taxes paid nor any other information deemed by the Tax Commissioner to be confidential.

Under penalty of law for false swearing (*West Virginia Code*, §61-5-3), Bidder hereby certifies that this certificate is true and accurate in all respects; and that if a contract is issued to Bidder and if anything contained within this certificate changes during the term of the contract, Bidder will notify the Purchasing Division in writing immediately.

Bidder: SERVICE PUMP & SUPPLY Signed: [Signature]
 Date: 11-17-08 Title: VICE PRESIDENT OF SALES

*Check any combination of preference consideration(s) indicated above, which you are entitled to receive.

STATE OF WEST VIRGINIA
Purchasing Division

PURCHASING AFFIDAVIT

VENDOR OWING A DEBT TO THE STATE:

West Virginia Code §5A-3-10a provides that: No contract or renewal of any contract may be awarded by the state or any of its political subdivisions to any vendor or prospective vendor when the vendor or prospective vendor or a related party to the vendor or prospective vendor is a debtor and the debt owed is an amount greater than one thousand dollars in the aggregate.

PUBLIC IMPROVEMENT CONTRACTS & DRUG-FREE WORKPLACE ACT:

West Virginia Code §21-1D-5 provides that: Any solicitation for a public improvement construction contract shall require each vendor that submits a bid for the work to submit at the same time an affidavit that the vendor has a written plan for a drug-free workplace policy in compliance with Article 1D, Chapter 21 of the West Virginia Code. A public improvement construction contract may not be awarded to a vendor who does not have a written plan for a drug-free workplace policy in compliance with Article 1D, Chapter 21 of the West Virginia Code and who has not submitted that plan to the appropriate contracting authority in timely fashion. For a vendor who is a subcontractor, compliance with Section 5, Article 1D, Chapter 21 of the West Virginia Code may take place before their work on the public improvement is begun.

ANTITRUST:

In submitting a bid to any agency for the state of West Virginia, the bidder offers and agrees that if the bid is accepted the bidder will convey, sell, assign or transfer to the state of West Virginia all rights, title and interest in and to all causes of action it may now or hereafter acquire under the antitrust laws of the United States and the state of West Virginia for price fixing and/or unreasonable restraints of trade relating to the particular commodities or services purchased or acquired by the state of West Virginia. Such assignment shall be made and become effective at the time the purchasing agency tenders the initial payment to the bidder.

I certify that this bid is made without prior understanding, agreement, or connection with any corporation, firm, limited liability company, partnership or person or entity submitting a bid for the same materials, supplies, equipment or services and is in all respects fair and without collusion or fraud. I further certify that I am authorized to sign the certification on behalf of the bidder or this bid.

LICENSING:

Vendors must be licensed and in good standing in accordance with any and all state and local laws and requirements by any state or local agency of West Virginia, including, but not limited to, the West Virginia Secretary of State's Office, the West Virginia Tax Department, West Virginia Insurance Commission, or any other state agencies or political subdivision. Furthermore, the vendor must provide all necessary releases to obtain information to enable the Director or spending unit to verify that the vendor is licensed and in good standing with the above entities.

CONFIDENTIALITY:

The vendor agrees that he or she will not disclose to anyone, directly or indirectly, any such personally identifiable information or other confidential information gained from the agency, unless the individual who is the subject of the information consents to the disclosure in writing or the disclosure is made pursuant to the agency's policies, procedures and rules. Vendors should visit www.state.wv.us/admin/purchase/privacy for the Notice of Agency Confidentiality Policies.

Under penalty of law for false swearing (West Virginia Code §61-5-3), it is hereby certified that the vendor acknowledges the information in this said affidavit and is in compliance with the requirements as stated.

Vendor's Name: SERVICE PUMP & SUPPLY

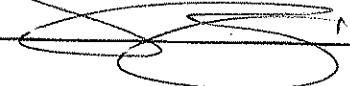
Authorized Signature:  Date: 11-18-08

6" Solids Handling ENVIROPRIME® Pump 6JSCD-DJDS-6068T-M

With its heavy-duty cast-iron construction, ability to dry-prime and re-prime automatically, this end-suction centrifugal pump leads the industry in construction, industrial and mining applications. The Thompson 6JSCD-DJDS-6068T-M ENVIROPRIME® Solids Handling Pump is designed for moderate flows to 1,350 gpm and high heads to 340 feet making it perfect for sewage bypass pumping or general construction dewatering.

Features

- Standard engine – John Deere 6068T
- Fully automatic, dry priming to 28 feet.
- Moderate heads to 340 feet; Maximum flows to 1,350 gpm.
- Solids handling to 3"
- Compact unit available with detachable trailer. Also available with removable drop-on Silent Knight® sound enclosure
- Maximum operating time is 26 hours @ 2,000 rpm
- ENVIROPRIME® compressor-assisted priming system prevents blow-by allowing pump to be environmentally safe

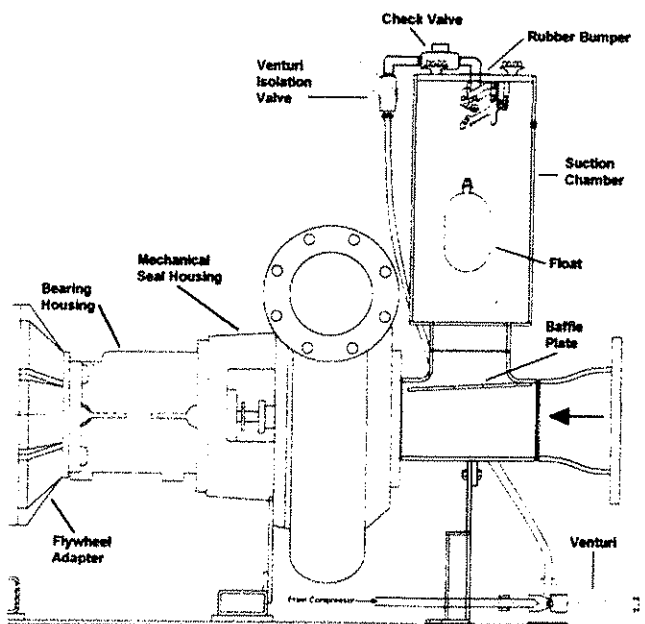

ENVIROPRIME®

Thompson's exclusive ENVIROPRIME® dry-priming system works in conjunction with the compressor/venturi priming system to prevent blow-by, such as sewage and waste from discharging onto the ground. The system works automatically, evacuating the air from the suction line during startup, as well as any air or gases introduced into the suction line during the pumping process.

Features and Benefits

- Handles large volumes of air, producing quicker priming times.
- Eliminates need for a venturi waste hose
- Extends the life of the pump by separating air and water, keeping the venturi from clogging and shutting down the system.
- Allows for optional noise suppressor
- This innovative system, along with high efficiency impellers, lessens power requirements resulting in reduced operating costs.



6" Solids Handling ENVIROPRIME® Pump 6JSCD-DJDS-6068T-M

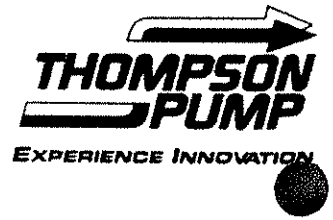

6JSCD-DJDS-6068T-M Dimensions

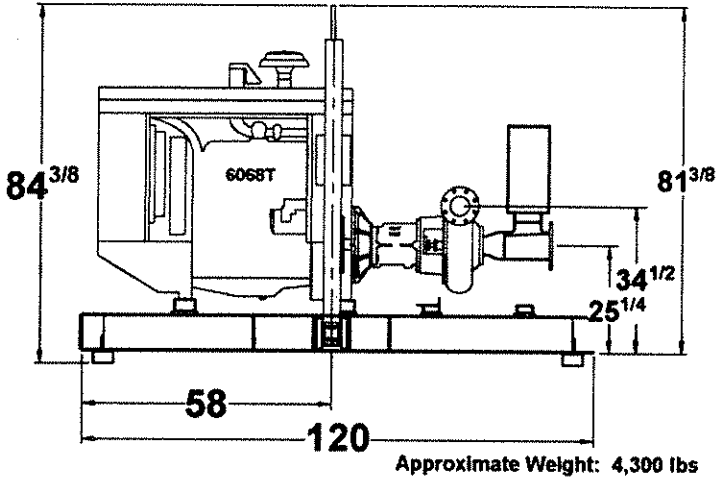

Materials of Construction

Pump Casing: Heavy-duty class 30 cast-iron
Impeller: Dynamically balanced, non-clogging, enclosed, class 30 cast iron with rear-equalizing vanes to reduce axial loading and prolong seal and bearing life; Diameter 14"
Mechanical Seal: 2.5" run-dry oil or grease lubricated with Tungsten Carbide rotating and Silicon Carbide stationary seal faces. Single inside mounted, non-pusher type with self-adjusting elastomeric bellows. Other components are 304 stainless steel and nitrile.
Bearings: Heavy-duty grease lubricated to carry both axial and radial loads.
Bearing Frame: Heavy-duty class 30 cast iron
Suction Wear Ring: Replaceable, class 30 cast iron
Shaft: 'Stress-proof' steel and fitted with a renewable 416 stainless steel shaft sleeve
Backplate: Rugged, back pull out design, heavy duty class 30 cast iron with tapered bore design

6JSCD-DJDS-6068T-M Performance Curve

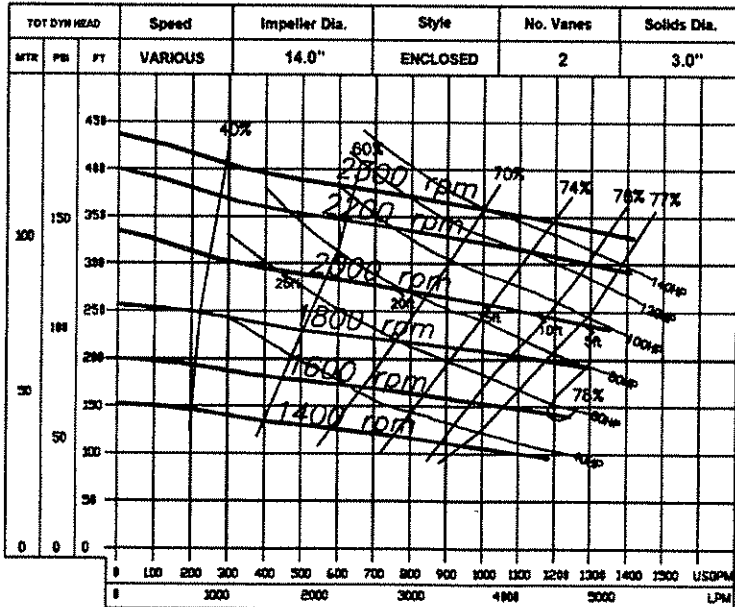

Engine Specifications

Engine: John Deere 6068T, 135 hp @ 2,000 rpm
Type: 6-cylinder, in-line, 4-cycle, water-cooled, turbo charged, direct-injected, Tier II diesel
Standard Equipment: Alternator, radiator, muffler, and exhaust stack with rain protection
Displacement: 414 cubic inches
Fuel Economy: .378 lb/hp-hr @ 2,000 rpm
Safety Shutdowns: High coolant temperature; Low oil pressure

Unit Specifications

Fuel Tank Capacity: 140 US gallons
Fuel Consumption: 5.36 gallons per hour
Maximum Operating Speed: 2,000 rpm
Maximum Operating Temperature: 212°F
Maximum Working Pressure: 175 psi
Maximum Suction Lift: 28 feet
Maximum Casing Pressure: 350 psi

In the interest of product improvement, Thompson Pump & Manufacturing reserves the right to change specifications without incurring any obligation for equipment previously or subsequently sold. Capacity, Head and Pump Curve are for comparative purposes. Consult engineering data for exact capabilities.
 4620 City Center Drive, Port Orange, FL, 32129, USA (800) 767-7310 * Fax (386) 761-0362

Email: sales@thompsonpump.com * www.thompsonpump.com

