

THE AMERICAN INSTITUTE OF ARCHITECTS

AIA Document A310 Bid Bond

KNOW ALL MEN BY THESE PRESENTS, THAT WE SimplexGrinnell LP
8910 Beckett Rd., West Chester, OH 45069

as Principal, hereinafter called the Principal, and Federal Insurance Company
15 Mountain View Road, Warren, NJ 07059

a corporation duly organized under the laws of the State of _____ IN

as Surety, hereinafter called the Surety, are held and firmly bound unto Cultural Center

1900 Kanawha Boulevard, East, Charleston, WV 25305

as Obligee, hereinafter called the Obligee, in the sum of Five Percent of Amount Bid

Dollars (\$ _____ 5% _____),

for the payment of which sum well and truly to be made, the said Principal and the said Surety, bind ourselves, our heirs, executors, administrators, successors and assigns, jointly and severally, firmly by these presents.

WHEREAS, the Principal has submitted a bid for Fire Alarm/Sprinkler Upgrades

NOW, THEREFORE, if the Obligee shall accept the bid of the Principal and the Principal shall enter into a Contract with the Obligee in accordance with the terms of such bid, and give such bond or bonds as may be specified in the bidding or Contract Documents with good and sufficient surety for the faithful performance of such Contract and for the prompt payment of labor and materials furnished in the prosecution thereof, or in the event of the failure of the Principal to enter such Contract and give such bond or bonds, if the Principal shall pay to the Obligee the difference not to exceed the penalty hereof between the amount specified in said bid and such larger amount for which the Obligee may in good faith contract with another party to perform the Work covered by said bid, then this obligation shall be null and void, otherwise to remain in full force and effect.

Signed and sealed this 20th day of May, 2009

(Witness)

SimplexGrinnell LP

(Principal)

By: Emilie Cook

OFFICIAL SEAL
NOTARY PUBLIC
STATE OF WEST VIRGINIA
EMILIE COOK

Ops Administrator
2800 7th Ave. Ste. 102
Charleston, WV 25312

My Commission Expires Feb. 13, 2012

(Title)
Dom

Federal Insurance Company

(Surety)

By: Jeannette Porini

Attorney-in-Fact

(Seal)
Jeannette Porini

(Title)

Lucy Bernatchy

(Witness)





**Chubb
Surety**

**POWER
OF
ATTORNEY**

**Federal Insurance Company
Vigilant Insurance Company
Pacific Indemnity Company**

**Attn: Surety Department
15 Mountain View Road
Warren, NJ 07059**

Know All by These Presents, That FEDERAL INSURANCE COMPANY, an Indiana corporation, VIGILANT INSURANCE COMPANY, a New York corporation, and PACIFIC INDEMNITY COMPANY, a Wisconsin corporation, do each hereby constitute and appoint **Jeannette Porrini and Stacy Rivera of Farmington, Connecticut**

each as their true and lawful Attorney-in-Fact to execute under such designation in their names and to affix their corporate seals to and deliver for and on their behalf as surety thereon or otherwise, bonds and undertakings and other writings obligatory in the nature thereof (other than bail bonds) given or executed in the course of business, and any instruments amending or altering the same, and consents to the modification or alteration of any instrument referred to in said bonds or obligations.

In Witness Whereof, said FEDERAL INSURANCE COMPANY, VIGILANT INSURANCE COMPANY, and PACIFIC INDEMNITY COMPANY have each executed and attested these presents and affixed their corporate seals on this **4th** day of **October, 2005**

Kenneth C. Wendel, Assistant Secretary

John P. Smith, Vice President

STATE OF NEW JERSEY

County of Somerset

ss.

On this **4th** day of **October, 2005**

before me, a Notary Public of New Jersey, personally came Kenneth C. Wendel, to me known to be Assistant Secretary of FEDERAL INSURANCE COMPANY, VIGILANT INSURANCE COMPANY, and PACIFIC INDEMNITY COMPANY, the companies which executed the foregoing Power of Attorney, and the said Kenneth C. Wendel, being by me duly sworn, did depose and say that he is Assistant Secretary of FEDERAL INSURANCE COMPANY, VIGILANT INSURANCE COMPANY, and PACIFIC INDEMNITY COMPANY and knows the corporate seals thereof, that the seals affixed to the foregoing Power of Attorney are such corporate seals and were thereto affixed by authority of the By-Laws of said Companies; and that he signed said Power of Attorney as Assistant Secretary of said Companies by like authority; and that he is acquainted with John P. Smith, and knows him to be Vice President of said Companies; and that the signature of John P. Smith, subscribed to said Power of Attorney is in the genuine handwriting of John P. Smith, and was thereto subscribed by authority of said By-Laws and in deponent's presence.

Notarial Seal



KAREN A. EDER
Notary Public, State of New Jersey
No. 2231647
Commission Expires Oct. 28, 2009

Notary Public

CERTIFICATION

Extract from the By-Laws of FEDERAL INSURANCE COMPANY, VIGILANT INSURANCE COMPANY, and PACIFIC INDEMNITY COMPANY:

"All powers of attorney for and on behalf of the Company may and shall be executed in the name and on behalf of the Company, either by the Chairman or the President or a Vice President or an Assistant Vice President, jointly with the Secretary or an Assistant Secretary, under their respective designations. The signature of such officers may be engraved, printed or lithographed. The signature of each of the following officers: Chairman, President, any Vice President, any Assistant Vice President, any Secretary, any Assistant Secretary and the seal of the Company may be affixed by facsimile to any power of attorney or to any certificate relating thereto appointing Assistant Secretaries or Attorneys-in-Fact for purposes only of executing and attesting bonds and undertakings and other writings obligatory in the nature thereof, and any such power of attorney or certificate bearing such facsimile signature or facsimile seal shall be valid and binding upon the Company and any such power so executed and certified by such facsimile signature and facsimile seal shall be valid and binding upon the Company with respect to any bond or undertaking to which it is attached."

I, Kenneth C. Wendel, Assistant Secretary of FEDERAL INSURANCE COMPANY, VIGILANT INSURANCE COMPANY, and PACIFIC INDEMNITY COMPANY (the "Companies") do hereby certify that

- (i) the foregoing extract of the By-Laws of the Companies is true and correct,
- (ii) the Companies are duly licensed and authorized to transact surety business in all 50 of the United States of America and the District of Columbia and are authorized by the U.S. Treasury Department; further, Federal and Vigilant are licensed in Puerto Rico and the U.S. Virgin Islands, and Federal is licensed in American Samoa, Guam, and each of the Provinces of Canada except Prince Edward Island; and
- (iii) the foregoing Power of Attorney is true, correct and in full force and effect.

Given under my hand and seals of said Companies at Warren, NJ this **May 20 2009**



Kenneth C. Wendel, Assistant Secretary

IN THE EVENT YOU WISH TO NOTIFY US OF A CLAIM, VERIFY THE AUTHENTICITY OF THIS BOND OR NOTIFY US OF ANY OTHER MATTER, PLEASE CONTACT US AT ADDRESS LISTED ABOVE, OR BY Telephone (908) 903-3493 Fax (908) 903-3656 e-mail: surety@chubb.com

WDL

FEDERAL INSURANCE COMPANY

STATEMENT OF ASSETS, LIABILITIES AND SURPLUS TO POLICYHOLDERS

Statutory Basis

DECEMBER 31, 2008

(in thousands of dollars)

<i>ASSETS</i>	<i>LIABILITIES AND SURPLUS TO POLICYHOLDERS</i>
Cash and Short Term Investments..... \$ 202,707	Outstanding Losses and Loss Expenses \$ 11,792,508
United States Government, State and Municipal Bonds..... 11,216,158	Unearned Premiums..... 3,522,120
Other Bonds..... 3,719,243	Reinsurance Premiums Payable 337,760
Stocks..... 609,081	Provision for Reinsurance 109,756
Other Invested Assets..... 1,771,227	Other Liabilities..... 958,636
TOTAL INVESTMENTS..... 17,518,416	TOTAL LIABILITIES 16,720,780
Investments in Affiliates:	
Chubb Investment Holdings, Inc..... 2,642,766	Capital Stock 20,980
Pacific Indemnity Company..... 1,831,737	Paid-In Surplus..... 3,106,809
Chubb Insurance Investment Holdings Ltd. .. 1,227,650	Unassigned Funds..... 9,008,020
Executive Risk Indemnity Inc..... 921,728	
CC Canada Holdings Ltd..... 583,643	SURPLUS TO POLICYHOLDERS..... 12,135,809
Great Northern Insurance Company 385,875	
Chubb European Investment Holdings SLP . 239,173	
Chubb Insurance Company of Australia... 224,157	
Vigilant Insurance Company..... 152,634	
Other Affiliates 307,470	
Premiums Receivable..... 1,498,855	
Other Assets 1,322,485	
TOTAL ADMITTED ASSETS \$ 28,856,589	TOTAL LIABILITIES AND SURPLUS TO POLICYHOLDERS..... \$ 28,856,589

Investments are valued in accordance with requirements of the National Association of Insurance Commissioners.
Investments valued at \$479,627,974 are deposited with government authorities as required by law.

A CORRECT STATEMENT:

RECEIVED

2009 MAY 20 PM 1:30

WV PURCHASING
DIVISION

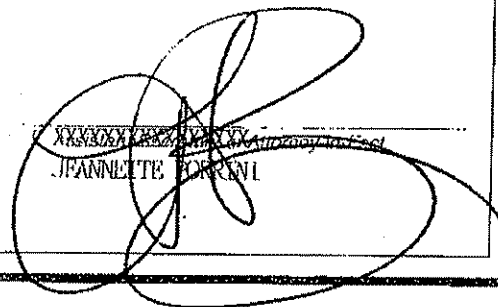
 J. PANNETTE

FORM OF PROPOSAL

OWNER: West Virginia Division of Culture & History
Charleston, WV

PROJECT: Cultural Center: Fire Alarm/ Sprinkler Upgrades, Charleston, WV

The undersigned, hereinafter called the Bidder, being familiar with and understanding the Bidding Documents and also having examined the site and being familiar with all local conditions affecting the Project, hereby proposes to furnish all labor, material, equipment, supplies and transportation, and to perform all Work in accordance with the Bidding Documents for the sum of:

BASE BID: 1,482,593.00

\$
(Bid amount shall be shown in both words and numbers. In the event of a difference between the written amount and the number amount, the written amount shall prevail.)

ALTERNATE #1: DEDUCT 2,900.00

\$
(Note that the Alternate Deduct price is included in the Base Bid amount.)

UNIT PRICES: FOR FURTHER DETAILS REFER TO SPECIFICATIONS

<u>Item No. 1</u> – Pull Station	Each \$ <u>294.00</u>
<u>Item No. 2</u> – Strobe	Each \$ <u>367.00</u>
<u>Item No. 3</u> – Speaker Strobe	Each \$ <u>367.00</u>
<u>Item No. 4</u> – Combination Heat Detector	Each \$ <u>205.00</u>
<u>Item No. 5</u> – Smoke Detector	Each \$ <u>205.00</u>
<u>Item No. 6</u> – Flow or Tamper Switch Connector	Each \$ <u>305.00</u>
<u>Item No. 7</u> – One Control Relay	Each \$ <u>305.00</u>
<u>Item No. 8</u> – Duct Smoke Detector	Each \$ <u>498.00</u>
<u>Item No. 9</u> – Monitor Module	Each \$ <u>305.00</u>

RESPECTFULLY SUBMITTED:

SIGNATURE: [Signature] DATE: 5/20/09

NAME: Wayne Legursky

FIRMNAME: SimplexGrinnell

FIRM ADDRESS: 2800 7th Ave Suite 102

Charleston WV 25312

TELEPHONE: 304-746-4081

CONTRACT TIME: _____

Contractor's License Number: WV010306

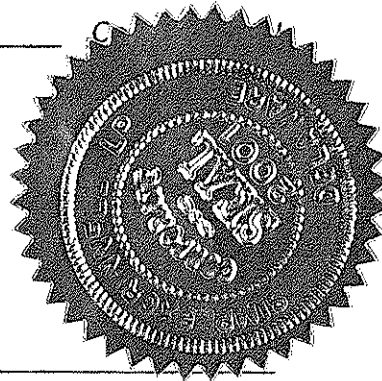

The successful Bidding Contractor agrees that from the compensation otherwise to be paid, the Owner may retain a sum in accordance with the following schedule for each day thereafter, Sundays and holidays included, that the work remains uncompleted, which sum is agreed upon as the proper measure of liquidated damages which the Owner will sustain per diem by the failure of the contractor to complete the work at the stipulated time, and the sum is not to be construed in any sense a penalty. The successful Bidder also shall pay any additional fees that the Engineer and the Engineer's consultants may accrue.

LIQUIDATED DAMAGES WILL BE ASSESSED AS FOLLOWS:

\$750.00/per day

The Owner will suffer financial loss if the Work is not Substantially Complete within the Contract Time. Allowance may be made for delays due to shortages of materials and/or energy resources, subject to proof by documentation, and also for delays due to strikes or other delays beyond the control of the Contractor. All delays and any claim for extension of the Contract Time must be properly documented in accordance with the Contract Documents by the Contractor and approved by the Engineer/Owner.

AUTHORITY AND RESPONSIBILITY OF THE ENGINEER:

The Engineer shall decide any and all questions that may arise as to the quality and acceptability of materials furnished, work performed, rate of progress of work, interpretation of drawings and specifications and all questions as to the acceptable fulfillment of the contract on the part of the contractor.

SUCCESSORS AND ASSIGNS:

This Agreement and all of the covenants hereof shall inure to the benefit of and be binding upon the Owner and the Contractor respectively and his partners, successors, assigns and legal representatives. Neither the Owner nor the Contractor shall have the right to assign, transfer or sublet his interests or obligations hereunder without consent of the other party.

PREBID MEETING IS MANDATORY

Mandatory attendance is required for all Bidders at the Pre-bid Meeting to familiarize themselves with the Project location, site conditions and other relevant information. Any Bidder who fails to attend the Pre-bid Meeting will cause that Bid to be disqualified.

ADDENDA ACKNOWLEDGMENT

The undersigned hereby acknowledges receipt of the following Addenda and has taken the information contained therein into full consideration in the formulation of this bid.

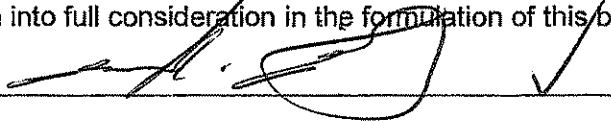
- Addenda No. 1 
- Addenda No. 2 _____
- Addenda No. 3 _____
- Addenda No. 4 _____
- Addenda No. 5 _____

Failure to acknowledge receipt of each Addendum may be cause for rejection of the bid.

SIGNATURE:  _____
Signature in Ink

DATE: 5/20/09

BIDDER'S CERTIFICATION

The Bidder hereby acknowledges that the following representations in this Proposal are material and not mere recitals:

1. Bidder has read and understands the Contract Documents and agrees to comply with all requirements of the Contract Documents, regardless of whether the Bidder has actual knowledge of the requirements and regardless of any statement or omission made by the Bidder, which might indicate a contrary intention.
2. The Bidder represents that the Proposal is based upon the Standards specified by the Contract Documents.
3. Bidder has visited the site, has become familiar with local conditions and has correlated personal observations about the requirements of the Contract Documents. The Bidder has no outstanding questions regarding the interpretation of the Contract Documents.
4. The Bidder shall make a good faith effort to ensure that all the Bidder employees, while working on Owner's property, shall not purchase, transfer, use or possess tobacco products, illegal drugs, alcohol, abuse prescription drugs in any way.
5. Bidder agrees to furnish any information requested by the Owner/Engineer to evaluate the responsibility of the Bidder.
6. The Bidder and each person signing on behalf of the Bidder certifies, and in the case of a joint Proposal, each party thereto certifies as to such party's organization, under penalty of perjury, that to the best of the undersigned's knowledge and belief:
 - 6.1 The Proposal has been prepared independently without collusion, consultation, communication or agreement, for the purpose of restricting competition as to any matter relating to such Proposal.
 - 6.2 Unless otherwise required by law, the costs, which have been quoted in the Proposal, have not been knowingly disclosed by the Bidder and will not knowingly be disclosed by the Bidder prior to the Proposal deadline, directly or indirectly, to any other Bidder that would have any interest in the Proposal costs.
 - 6.3 No attempt has been made or will be made by the Bidder to induce any other individual, partnership or corporation to submit or not to submit a Proposal for the purpose of restricting competition.

The successful bidder will be required to furnish a copy of their Contractor's License prior to issuance of a Purchase Order/Contract.

END OF SECTION 00120

LIST OF PROPOSED SUBCONTRACTORS EQUIPMENT / MATERIAL SUPPLIERS

(This form must be included in bid of faxed to the OWNER/ENGINEER within two hours of close of bid)

List below each major branch of work and major equipment / material category for this proposal and the subcontractor or supplier proposed for that portion of work; also provide the contractor's license number for each subcontractor as required by the "West Virginia Contractor Licensing Act." If the branch of work is to be completed solely by an equipment / material supplier, indicate by notation below in the contractor license number column. The bidder may be requested to change an unsatisfactory subcontractor or equipment / material supplier. The contractor is responsible for selecting or changing subcontractor or equipment / material supplier. The Owner or Engineer may indicate their concerns about any entity listed which they have reason to believe past experience indicates poor performance may be expected. It is the responsibility of any contractor soliciting bids or quotes from subcontractors to verify the eligibility of all proposed subcontractors and equipment / material suppliers being proposed to perform the work. The Contractor has full responsibility for satisfactory execution of all work in accordance with the contract documents. Any change of proposed subcontractors or material suppliers shall be at no additional cost to Owner, as the Contractor has full responsibility for execution of the work.

I  representing Simplex Grinnell
(Signature of Responsible Contractor) (Company Name)

on this date 5/20/09 submit the following list of subcontractors and major material suppliers for your review and comment. This is the final and complete list of companies who will be performing work or supplying materials for **CULTURAL CENTER FIRE ALARM/SPRINKLER UPGRADES.**

I agree that once the subcontractors and material suppliers listed are approved for use by the Owner and Engineer, no other subcontractors or substitute for any subcontractors listed below, will be used in the performance of the contract without written approval of the Owner and Engineer. I further agree that if non-approved subcontractors or suppliers are used, my company shall be placed on probation, unless in its reasonable discretion, the STATE OF WV determines otherwise.

LIST OF PROPOSED SUBCONTRACTORS EQUIPMENT / MATERIAL SUPPLIERS

(This form must be included in bid of faxed to the OWNER/ENGINEER within two hours of close of bid)

Branch of work / Material Category	Complete Name and Address Subcontractor (to be completed by Contractor)	Complete Name and Address Supplier	Contractor License #
SPRINKLER			
Sprinkler Contractor	Simplex Grinnell 2800 7th Ave Charleston, WV		WV0103 06
ELECTRICAL			
Electrical Contractor	Progressive Electric PO Box 3695 Charleston, WV, 25336		
Fire Alarm	Simplex		
GENERAL CONSTRUCTION			
General Trades Contractor	Simplex Grinnell 2800 7th Avenue Charleston, WV 25312		



State of West Virginia
 Department of Administration
 Purchasing Division
 2019 Washington Street East
 Post Office Box 50130
 Charleston, WV 25305-0130

Request for Quotation

RFQ NUMBER
DCH09084

PAGE
1

ADDRESS CORRESPONDENCE TO ATTENTION OF
**SHELLY MURRAY
 304-558-8801**

VENDOR

RFQ COPY
 TYPE NAME/ADDRESS HERE

SHIP TO

DIVISION OF CULTURE & HISTORY
 CULTURAL CENTER
 1900 KANAWHA BOULEVARD, EAST
 CHARLESTON, WV
 25305-0300 558-0220

DATE PRINTED	TERMS OF SALE	SHIP VIA	FOR	FREIGHT TERMS
04/01/2009				

OPENING DATE: **05/15/2009** BID OPENING TIME **01:30PM**

LINE	QUANTITY	UOP	CAT. NO.	ITEM NUMBER	UNIT PRICE	AMOUNT
<p>THE WEST VIRGINIA PURCHASING DIVISION FOR THE AGENCY, THE WEST VIRGINIA DIVISION OF CULTURE & HISTORY, IS SOLICITING BIDS FOR A FIRE ALARM AND SPRINKLER UPGRADE AT THE CULTURAL CENTER LOCATED AT THE STATE CAPITOL COMPLEX, 1900 KANAWHA BOULEVARD EAST, CHARLESTON, WV.</p> <p>A MANDATORY PRE-BID MEETING WILL BE HELD ON 4/21/2009 AT 10:00 AM IN THE GREEN ROOM OF THE CULTURAL CENTER. ALL VENDORS INTERESTED IN SUBMITTING A BID FOR THIS PROJECT MUST ATTEND THIS MEETING. ANY VENDOR FAILING TO ATTEND WILL BE DISQUALIFIED. NO ONE PERSON MAY REPRESENT MORE THAN ONE VENDOR.</p> <p>TECHNICAL QUESTIONS MUST BE SUBMITTED IN WRITING TO SHELLY MURRAY IN THE WEST VIRGINIA PURCHASING DIVISION VIA MAIL AT THE ADDRESS SHOWN AT THE TOP OF THIS RFQ, VIA FAX AT 304-558-4115, OR VIA EMAIL AT SHELLY.L.MURRAY@WV.GOV. DEADLINE FOR ALL TECHNICAL QUESTIONS IS 4/28/2009 AT THE CLOSE OF BUSINESS. ALL TECHNICAL QUESTIONS RECEIVED, IF ANY, WILL BE ANSWERED BY ADDENDUM AFTER THE DEADLINE.</p> <p>QUESTIONS CONCERNING THE ACTUAL PROCESS BY WHICH A VENDOR MAY SUBMIT A PROPOSAL TO THE STATE OF WEST VIRGINIA ARE NOT CONSIDERED TO BE TECHNICAL QUESTIONS AND MAY BE SUBMITTED AT ANY TIME PRIOR TO THE RFQ OPENING DATE AND IN ANY FORMAT.</p>						

SEE REVERSE SIDE FOR TERMS AND CONDITIONS

NATURE	TELEPHONE	DATE
FEIN	ADDRESS CHANGES TO BE NOTED ABOVE	

WHEN RESPONDING TO RFQ, INSERT NAME AND ADDRESS IN SPACE ABOVE LABELED 'VENDOR'

**GENERAL TERMS & CONDITIONS
REQUEST FOR QUOTATION (RFQ) AND REQUEST FOR PROPOSAL (RFP)**

1. Awards will be made in the best interest of the State of West Virginia.
2. The State may accept or reject in part, or in whole, any bid.
3. All quotations are governed by the *West Virginia Code* and the *Legislative Rules* of the Purchasing Division.
4. Prior to any award, the apparent successful vendor must be properly registered with the Purchasing Division and have paid the required \$125 fee.
5. All services performed or goods delivered under State Purchase Order/Contracts are to be continued for the term of the Purchase Order/Contracts, contingent upon funds being appropriated by the Legislature or otherwise being made available. In the event funds are not appropriated or otherwise available for these services or goods, this Purchase Order/Contract becomes void and of no effect after June 30.
6. Payment may only be made after the delivery and acceptance of goods or services.
7. Interest may be paid for late payment in accordance with the *West Virginia Code*.
8. Vendor preference will be granted upon written request in accordance with the *West Virginia Code*.
9. The State of West Virginia is exempt from federal and state taxes and will not pay or reimburse such taxes.
10. The Director of Purchasing may cancel any Purchase Order/Contract upon 30 days written notice to the seller.
11. The laws of the State of West Virginia and the *Legislative Rules* of the Purchasing Division shall govern all rights and duties under the Contract, including without limitation the validity of this Purchase Order/Contract.
12. Any reference to automatic renewal is hereby deleted. The Contract may be renewed only upon mutual written agreement of the parties.
13. **BANKRUPTCY:** In the event the vendor/contractor files for bankruptcy protection, this Contract may be deemed null and void, and terminated without further order.
14. **HIPAA BUSINESS ASSOCIATE ADDENDUM:** The West Virginia State Government HIPAA Business Associate Addendum (BAA), approved by the Attorney General, and available online at the Purchasing Division's web site (<http://www.state.wv.us/admin/purchase/vrc/hipaa.htm>) is hereby made part of the agreement. Provided that, the Agency meets the definition of a Cover Entity (45 CFR §160.103) and will be disclosing Protected Health Information (45 CFR §160.103) to the vendor.
15. **WEST VIRGINIA ALCOHOL & DRUG-FREE WORKPLACE ACT:** If this Contract constitutes a public improvement construction contract as set forth in Article 1D, Chapter 21 of the West Virginia Code ("The West Virginia Alcohol and Drug-Free Workplace Act"), then the following language shall hereby become part of this Contract: "The contractor and its subcontractors shall implement and maintain a written drug-free workplace policy in compliance with the West Virginia Alcohol and Drug-Free Workplace Act, as set forth in Article 1D, Chapter 21 of the West Virginia Code. The contractor and its subcontractors shall provide a sworn statement in writing, under the penalties of perjury, that they maintain a valid drug-free work place policy in compliance with the West Virginia and Drug-Free Workplace Act. It is understood and agreed that this Contract shall be cancelled by the awarding authority if the Contractor: 1) Fails to implement its drug-free workplace policy; 2) Fails to provide information regarding implementation of the contractor's drug-free workplace policy at the request of the public authority; or 3) Provides to the public authority false information regarding the contractor's drug-free workplace policy."

INSTRUCTIONS TO BIDDERS

1. Use the quotation forms provided by the Purchasing Division.
2. **SPECIFICATIONS:** Items offered must be in compliance with the specifications. Any deviation from the specifications must be clearly indicated by the bidder. Alternates offered by the bidder as **EQUAL** to the specifications must be clearly defined. A bidder offering an alternate should attach complete specifications and literature to the bid. The Purchasing Division may waive minor deviations to specifications.
3. Complete all sections of the quotation form.
4. Unit prices shall prevail in case of discrepancy.
5. All quotations are considered F.O.B. destination unless alternate shipping terms are clearly identified in the quotation.
6. **BID SUBMISSION:** All quotations must be delivered by the bidder to the office listed below prior to the date and time of the bid opening. Failure of the bidder to deliver the quotations on time will result in bid disqualifications: Department of Administration, Purchasing Division, 2019 Washington Street East, P.O. Box 50130, Charleston, WV 25305-0130



State of West Virginia
 Department of Administration
 Purchasing Division
 2019 Washington Street East
 Post Office Box 50130
 Charleston, WV 25305-0130

Request for Quotation

RFQ NUMBER
DCH09084

PAGE
2

ADDRESS CORRESPONDENCE TO ATTENTION OF
**SHELLY MURRAY
 304-558-8801**

VENDOR

RFQ COPY
 TYPE NAME/ADDRESS HERE

SHIP TO

DIVISION OF CULTURE & HISTORY
 CULTURAL CENTER
 1900 KANAWHA BOULEVARD, EAST
 CHARLESTON, WV
 25305-0300 558-0220

DATE PRINTED	TERMS OF SALE	SHIP VIA	FOB	FREIGHT TERMS
04/01/2009				

OPENING DATE: **05/15/2009** BID OPENING TIME **01:30PM**

LINE	QUANTITY	UOP	CAT NO	ITEM NUMBER	UNIT PRICE	AMOUNT
01	1	LS		340-20		
<p>FIRE ALARM/SPRINKLER UPGRADE</p> <p>EXHIBIT 5</p> <p>WEST VIRGINIA CODE 21-1D-5 PROVIDES THAT: ANY SOLICITATION FOR A PUBLIC IMPROVEMENT CONSTRUCTION CONTRACT REQUIRES EACH VENDOR THAT SUBMITS A BID FOR THE WORK TO SUBMIT AT THE SAME TIME AN AFFIDAVIT OF COMPLIANCE WITH THE BID. THE ENCLOSED DRUG-FREE WORKPLACE AFFIDAVIT MUST BE SIGNED AND SUBMITTED WITH THE BID AS EVIDENCE OF THE VENDOR'S COMPLIANCE WITH THE PROVISIONS OF ARTICLE 1D, CHAPTER 21 OF THE WEST VIRGINIA CODE. FAILURE TO SUBMIT THE SIGNED DRUG-FREE WORKPLACE AFFIDAVIT WITH THE BID SHALL RESULT IN DISQUALIFICATION OF SUCH BID.</p> <p>NOTICE TO PROCEED: THIS CONTRACT IS TO BE PERFORMED WITHIN 365 CALENDAR DAYS AFTER THE NOTICE TO PROCEED IS RECEIVED. UNLESS OTHERWISE SPECIFIED, THE FULLY EXECUTED PURCHASE ORDER WILL BE CONSIDERED NOTICE TO PROCEED.</p> <p>CANCELLATION: THE DIRECTOR OF PURCHASING RESERVES THE RIGHT TO CANCEL THIS CONTRACT IMMEDIATELY UPON WRITTEN NOTICE TO THE VENDOR IF THE MATERIALS OR WORKMANSHIP SUPPLIED ARE OF AN INFERIOR QUALITY OR DO NOT CONFORM WITH THE SPECIFICATIONS OF THE BID AND CONTRACT HERE IN.</p> <p>WAGE RATES: THE CONTRACTOR OR SUBCONTRACTOR SHALL PAY THE HIGHER OF THE U.S. DEPARTMENT OF LABOR MINIMUM WAGE RATES AS ESTABLISHED FOR KANAWHA COUNTY, PURSUANT TO WEST VIRGINIA CODE 21-5A, ET, SEQ. (PREVAILING</p>						

SEE REVERSE SIDE FOR TERMS AND CONDITIONS

NATURE	TELEPHONE	DATE
E	FEIN	ADDRESS CHANGES TO BE NOTED ABOVE

WHEN RESPONDING TO RFQ, INSERT NAME AND ADDRESS IN SPACE ABOVE LABELED 'VENDOR'



State of West Virginia
 Department of Administration
 Purchasing Division
 2019 Washington Street East
 Post Office Box 50130
 Charleston, WV 25305-0130

**Request for
 Quotation**

RFQ NUMBER
DCH09084

PAGE
3

ADDRESS CORRESPONDENCE TO ATTENTION OF
**SHELLY MURRAY
 304-558-8801**

RFQ COPY

TYPE NAME/ADDRESS HERE

SHIP TO

**DIVISION OF CULTURE & HISTORY
 CULTURAL CENTER
 1900 KANAWHA BOULEVARD, EAST
 CHARLESTON, WV
 25305-0300 558-0220**

DATE PRINTED 04/01/2009	TERMS OF SALE	SHIP VIA	FOB	FREIGHT TERMS
BID OPENING DATE: 05/15/2009		BID OPENING TIME 01:30PM		

LINE	QUANTITY	UOP	CAT NO	ITEM NUMBER	UNIT PRICE	AMOUNT
<p>WAGE RATES APPLY TO THIS PROJECT)</p> <p>ARBITRATION: ANY REFERENCES MADE TO ARBITRATION OR INTEREST FOR PAYMENTS DUE (EXCEPT FOR ANY INTEREST REQUIRED BY STATE LAW) CONTAINED IN THIS CONTRACT OR IN ANY AMERICAN INSTITUTE OF ARCHITECTS DOCUMENTS PERTAINING TO THIS CONTRACT ARE HEREBY DELETED.</p> <p>WORKERS' COMPENSATION: VENDOR IS REQUIRED TO PROVIDE A CERTIFICATE FROM WORKERS' COMPENSATION IF SUCCESSFUL.</p> <p>ALL OF THE ITEMS CHECKED BELOW WILL BE A REQUIREMENT OF THIS CONTRACT:</p> <p>(XX) INSURANCE: SUCCESSFUL VENDOR SHALL FURNISH PROOF OF COMMERCIAL GENERAL LIABILITY INSURANCE PRIOR TO ISSUANCE OF CONTRACT. UNLESS OTHERWISE SPECIFIED IN THE BID DOCUMENTS, THE MINIMUM AMOUNT OF INSURANCE COVERAGE REQUIRED IS \$250,000.</p> <p>() BUILDERS RISK INSURANCE: SUCCESSFUL VENDOR SHALL FURNISH PROOF OF BUILDERS RISK - ALL RISK INSURANCE IN AN AMOUNT EQUAL TO 100% OF THE AMOUNT OF THE CONTRACT.</p> <p>(XX) BONDS: FIVE PERCENT (5%) OF THE TOTAL AMOUNT OF THE BID PAYABLE TO THE STATE OF WEST VIRGINIA, SHALL BE SUBMITTED WITH EACH BID AS A BID BOND. THE SUCCESSFUL BIDDER SHALL ALSO FURNISH A PERFORMANCE BOND AND LABOR/MATERIAL BOND FOR 100% OF THE AMOUNT OF THE CONTRACT. BONDS MAY BE PROVIDED IN THE FORM OF A CERTIFIED CHECK IRREVOCABLE LETTER OF CREDIT, OR BOND FURNISHED BY A SOLVENT SURETY COMPANY AUTHORIZED TO DO BUSINESS IN THE STATE OF WEST VIRGINIA. A LETTER OF CREDIT SUBMITTED IN LIEU OF A BOND WILL ONLY BE ALLOWED FOR PROJECTS UNDER \$100,000. PERSONAL OR BUSINESS CHECKS ARE NOT ACCEPCTABLE IN LIEU OF THE 5% BID BOND, PERFORMANCE</p>						

SEE REVERSE SIDE FOR TERMS AND CONDITIONS

SIGNATURE	TELEPHONE	DATE
TITLE	FEIN	ADDRESS CHANGES TO BE NOTED ABOVE

WHEN RESPONDING TO RFQ, INSERT NAME AND ADDRESS IN SPACE ABOVE LABELED 'VENDOR'



State of West Virginia
 Department of Administration
 Purchasing Division
 2019 Washington Street East
 Post Office Box 50130
 Charleston, WV 25305-0130

Request for Quotation

RFQ NUMBER
DCH09084

PAGE
4

ADDRESS CORRESPONDENCE TO ATTENTION OF
SHELLY MURRAY
304-558-8801

RFQ COPY
 TYPE NAME/ADDRESS HERE

DIVISION OF CULTURE & HISTORY
CULTURAL CENTER
1900 KANAWHA BOULEVARD, EAST
CHARLESTON, WV
25305-0300 558-0220

DATE PRINTED	TERMS OF SALE	SHIP VIA	FOB	FREIGHT TERMS
04/01/2009				

BID OPENING DATE: **05/15/2009** BID OPENING TIME **01:30PM**

LINE	QUANTITY	UOP	CAT NO	ITEM NUMBER	UNIT PRICE	AMOUNT
<p>BOND, OR LABOR AND MATERIAL BOND.</p> <p>() MAINTENANCE BOND: A TWO (2) YEAR MAINTENANCE BOND COVERING THE ROOFING SYSTEM WILL BE A REQUIREMENT OF THE SUCCESSFUL VENDOR.</p> <p>REV. 11/00</p> <p>EXHIBIT 7</p> <p>DOMESTIC ALUMINUM, GLASS & STEEL IN PUBLIC WORKS PROJECTS</p> <p>IN ACCORDANCE WITH WEST VIRGINIA CODE 5-19-1 ET., SEQ., EVERY CONTRACT FOR CONSTRUCTION, RECONSTRUCTION, ALTERATION, REPAIR, IMPROVEMENT OR MAINTENANCE OF PUBLIC WORKS, WHERE THE COST IS MORE THAN \$50,000 AND, IN THE CASE OF STEEL ONLY, WHERE THE COST OF STEEL IS MORE THAN \$50,000 OR WHERE MORE THAN 10,000 POUNDS OF STEEL ARE REQUIRED, THE STATE WILL ACCEPT ONLY ALUMINUM GLASS, OR STEEL PRODUCTS PRODUCED IN THE UNITED STATES. IN ADDITION, ITEMS OF MACHINERY OR EQUIPMENT PURCHASED FOR USE AT THE SITE OF PUBLIC WORKS SHALL BE MADE OF DOMESTIC ALUMINUM, GLASS OR STEEL, UNLESS THE COST OF THE PRODUCT IS LESS THAN \$50,000 OR LESS THAN 10,000 POUNDS OF STEEL ARE USED IN PUBLIC WORKS PROJECTS.</p> <p>FOREIGN MADE ALUMINUM, GLASS OR STEEL PRODUCTS MAY BE ACCEPTED ONLY IF THE COST OF DOMESTIC PRODUCTS IS FOUND TO BE UNREASONABLE. SUCH COST IS UNREASONABLE IF IT IS 20% OR MORE HIGHER THAN THE BID PRICE FOR FOREIGN MADE PRODUCTS. IF THE DOMESTIC ALUMINUM, GLASS OR STEEL PRODUCTS TO BE SUPPLIED OR PRODUCED IN A "SUBSTANTIAL LABOR SURPLUS AREA", AS DEFINED BY THE UNITED STATES DEPARTMENT OF LABOR, FOREIGN PRODUCTS MAY BE SUPPLIED</p>						

SEE REVERSE SIDE FOR TERMS AND CONDITIONS

SIGNATURE	TELEPHONE	DATE
	FEIN	ADDRESS CHANGES TO BE NOTED ABOVE

WHEN RESPONDING TO RFQ, INSERT NAME AND ADDRESS IN SPACE ABOVE LABELED 'VENDOR'



State of West Virginia
 Department of Administration
 Purchasing Division
 2019 Washington Street East
 Post Office Box 50130
 Charleston, WV 25305-0130

**Request for
 Quotation**

RFQ NUMBER
DCH09084

PAGE
5

ADDRESS CORRESPONDENCE TO ATTENTION OF
**SHELLY MURRAY
 304-558-8801**

RFQ COPY
 TYPE NAME/ADDRESS HERE

**DIVISION OF CULTURE & HISTORY
 CULTURAL CENTER
 1900 KANAWHA BOULEVARD, EAST
 CHARLESTON, WV
 25305-0300 558-0220**

DATE PRINTED	TERMS OF SALE	SHIP VIA	F.O.B.	FREIGHT TERMS
04/01/2009				

BID OPENING DATE: **05/15/2009** BID OPENING TIME **01:30PM**

LINE	QUANTITY	UOP	CAT NO	ITEM NUMBER	UNIT PRICE	AMOUNT
<p>ONLY IF DOMESTIC PRODUCTS ARE 30% OR MORE HIGHER IN PRICE THAN THE FOREIGN MADE PRODUCTS.</p> <p>IF, PRIOR TO THE AWARD OF A CONTRACT UNDER THE ABOVE PROVISIONS, THE SPENDING OFFICER OF THE SPENDING UNIT DETERMINES THAT THERE EXISTS A BID FOR LIKE FOREIGN ALUMINUM, GLASS OR STEEL THAT IS REASONABLE AND LOWER THAN THE LOWEST BID DOMESTIC PRODUCTS, THE SPENDING OFFICE MAY REQUEST, IN WRITING, A REEVALUATION AND REDUCTION IN THE LOWEST BID FOR SUCH DOMESTIC PRODUCTS. ALL VENDORS MUST INDICATE IN THEIR BID IF THEY ARE SUPPLYING FOREIGN ALUMINUM, GLASS OR STEEL.</p> <p>REV. 3/88</p> <p>EXHIBIT 9</p> <p>NOTICE FOR ISSUANCE & ACKNOWLEDGEMENT OF CONSTRUCTION PROJECT ADDENDA</p> <p>THE ARCHITECT/ENGINEER AND/OR AGENCY SHALL BE REQUIRED TO ABIDE BY THE FOLLOWING SCHEDULE IN ISSUING CONSTRUCTION PROJECT ADDENDA FOR STATE AGENCIES:</p> <p>(1) THE ARCHITECT/ENGINEER SHALL PREPARE THE ADDENDUM AND A LIST OF ALL PARTIES THAT HAVE PROCURED DRAWINGS AND SPECIFICATIONS FOR THE PROJECT. THE ADDENDUM AND LIST SHALL BE FORWARDED TO THE BUYER IN THE STATE PURCHASING DIVISION. THE ARCHITECT/ENGINEER SHALL ALSO SEND A COPY OF THE ADDENDUM TO THE STATE AGENCY FOR WHICH THE CONTRACT IS ISSUED.</p> <p>(2) THE BUYER SHALL SEND THE ADDENDUM TO ALL INTERESTED PARTIES AND, IF NECESSARY, EXTEND THE BID OPENING DATE. ANY ADDENDUM SHOULD BE RECEIVED BY THE</p>						

SEE REVERSE SIDE FOR TERMS AND CONDITIONS

SIGNATURE	TELEPHONE	DATE
TITLE	FEIN	ADDRESS CHANGES TO BE NOTED ABOVE

WHEN RESPONDING TO RFQ, INSERT NAME AND ADDRESS IN SPACE ABOVE LABELED 'VENDOR'



State of West Virginia
 Department of Administration
 Purchasing Division
 2019 Washington Street East
 Post Office Box 50130
 Charleston, WV 25305-0130

Request for Quotation

RFQ NUMBER
DCH09084

PAGE
6

ADDRESS CORRESPONDENCE TO ATTENTION OF
**SHELLY MURRAY
 304-558-8801**

VENDOR

RFQ COPY
 TYPE NAME/ADDRESS HERE

SHIP TO

DIVISION OF CULTURE & HISTORY
 CULTURAL CENTER
 1900 KANAWHA BOULEVARD, EAST
 CHARLESTON, WV
 25305-0300 558-0220

DATE PRINTED	TERMS OF SALE	SHIP VIA	FOB	FREIGHT TERMS
04/01/2009				

OPENING DATE: **05/15/2009** BID OPENING TIME **01:30PM**

LINE	QUANTITY	UOP	CAT NO	ITEM NUMBER	UNIT PRICE	AMOUNT
<p>BUYER WITHIN FOURTEEN (14) DAYS PRIOR TO THE BID OPENING DATE.</p> <p>(3) ALL ADDENDA SHOULD BE FORMALLY ACKNOWLEDGED BY ALL BIDDERS AND SUBMITTED TO THE STATE PURCHASING DIVISION. THE SAME RULES AND REGULATIONS THAT APPLY TO THE ORIGINAL BIDDING DOCUMENT SHALL ALSO APPLY TO AN ADDENDUM DOCUMENT. THE ONLY EXCEPTION MAY BE FOR AN ADDENDUM THAT IS ISSUED FOR THE SOLE PURPOSE OF CHANGING A BID OPENING TIME AND/OR DATE.</p> <p>REV. 11/96</p> <p>EXHIBIT 10</p> <p>ADDENDUM ACKNOWLEDGEMENT</p> <p>I HEREBY ACKNOWLEDGE RECEIPT OF THE FOLLOWING CHECKED ADDENDUM(S) AND HAVE MADE THE NECESSARY REVISIONS TO MY PROPOSAL, PLANS AND/OR SPECIFICATION, ETC.</p> <p>ADDENDUM NOS. :</p> <p>NO. 1 ✓</p> <p>NO. 2 </p> <p>NO. 3 </p> <p>NO. 4 </p> <p>NO. 5 </p> <p>I UNDERSTAND THAT FAILURE TO CONFIRM THE RECEIPT OF TH</p>						

SEE REVERSE SIDE FOR TERMS AND CONDITIONS

SIGNATURE	TELEPHONE	DATE
LE	FEN	ADDRESS CHANGES TO BE NOTED ABOVE

WHEN RESPONDING TO RFQ, INSERT NAME AND ADDRESS IN SPACE ABOVE LABELED 'VENDOR'



State of West Virginia
 Department of Administration
 Purchasing Division
 2019 Washington Street East
 Post Office Box 50130
 Charleston, WV 25305-0130

**Request for
 Quotation**

RFQ NUMBER
DCH09084

PAGE
7

ADDRESS CORRESPONDENCE TO ATTENTION OF
**SHELLY MURRAY
 304-558-8801**

RFQ COPY
 TYPE NAME/ADDRESS HERE

**DIVISION OF CULTURE & HISTORY
 CULTURAL CENTER
 1900 KANAWHA BOULEVARD, EAST
 CHARLESTON, WV
 25305-0300 558-0220**

DATE PRINTED	TERMS OF SALE	SHIP VIA	FOB	FREIGHT TERMS
04/01/2009				

BID OPENING DATE: **05/15/2009** BID OPENING TIME **01:30PM**

LINE	QUANTITY	UOP	CAT NO	ITEM NUMBER	UNIT PRICE	AMOUNT
<p>ADDENDUM(S) MAY BE CAUSE FOR REJECTION OF THE BIDS.</p> <p>VENDOR MUST CLEARLY UNDERSTAND THAT ANY VERBAL REPRESENTATION MADE OR ASSUMED TO BE MADE DURING ANY ORAL DISCUSSION HELD BETWEEN VENDOR'S REPRESENTATIVES AND ANY STATE PERSONNEL IS NOT BINDING. ONLY THE INFORMATION ISSUED IN WRITING AND ADDED TO THE SPECIFICATIONS BY AN OFFICIAL ADDENDUM IS BINDING.</p> <p>..... SIGNATURE</p> <p>..... <i>Shirley Garrison</i> COMPANY</p> <p>..... <i>5/20/09</i> DATE</p> <p>REV. 11/96</p> <p>CONTRACTORS LICENSE</p> <p>WEST VIRGINIA STATE CODE 21-11-2 REQUIRES THAT ALL PERSONS DESIRING TO PERFORM CONTRACTING WORK IN THIS STATE MUST BE LICENSED. THE WEST VIRGINIA CONTRACTORS LICENSING BOARD IS EMPOWERED TO ISSUE THE CONTRACTORS LICENSE. APPLICATIONS FOR A CONTRACTORS LICENSE MAY BE MADE BY CONTACTING THE WEST VIRGINIA DIVISION OF LABOR CAPITOL COMPLEX, BUILDING 3, ROOM 319, CHARLESTON, WV 25305. TELEPHONE: (304) 558-7890.</p> <p>WEST VIRGINIA STATE CODE 21-11-11 REQUIRES ANY PROSPECTIVE BIDDER TO INCLUDE THE CONTRACTORS LICENSE NUMBER ON THEIR BID.</p> <p>BIDDER TO COMPLETE:</p>						

SEE REVERSE SIDE FOR TERMS AND CONDITIONS

SIGNATURE _____ TELEPHONE _____ DATE _____

TITLE _____ FEIN _____ ADDRESS CHANGES TO BE NOTED ABOVE

WHEN RESPONDING TO RFQ, INSERT NAME AND ADDRESS IN SPACE ABOVE LABELED 'VENDOR'



State of West Virginia
 Department of Administration
 Purchasing Division
 2019 Washington Street East
 Post Office Box 50130
 Charleston, WV 25305-0130

Request for Quotation

RFQ NUMBER
DCH09084

PAGE
8

ADDRESS CORRESPONDENCE TO/ATTENTION OF
**SHELLY MURRAY
 304-558-8801**

RFQ COPY
 TYPE NAME/ADDRESS HERE

DIVISION OF CULTURE & HISTORY
 CULTURAL CENTER
 1900 KANAWHA BOULEVARD, EAST
 CHARLESTON, WV
 25305-0300 558-0220

DATE PRINTED	TERMS OF SALE	SHIP VIA	FOB	FREIGHT TERMS
04/01/2009				

OPENING DATE: **05/15/2009** BID OPENING TIME **01:30PM**

LINE	QUANTITY	UOP	QTY NO	ITEM NUMBER	UNIT PRICE	AMOUNT
<p>CONTRACTORS NAME: <i>Simplex Council</i></p> <p>CONTRACTORS LICENSE NO.: <i>WV 010306</i></p> <p>THE SUCCESSFUL BIDDER WILL BE REQUIRED TO FURNISH A COPY OF THEIR CONTRACTORS LICENSE PRIOR TO ISSUANCE OF A PURCHASE ORDER/CONTRACT</p> <p>APPLICABLE LAW</p> <p>THE WEST VIRGINIA STATE CODE, PURCHASING DIVISION RULES AND REGULATIONS, AND THE INFORMATION PROVIDED IN THE "REQUEST FOR QUOTATION" ISSUED BY THE PURCHASING DIVISION IS THE SOLE AUTHORITY GOVERNING THIS PROCUREMENT.</p> <p>ANY INFORMATION PROVIDED IN SPECIFICATION MANUALS, OR ANY OTHER SOURCE, VERBAL OR WRITTEN, WHICH CONTRADICTS OR ALTERS THE INFORMATION PROVIDED FROM THE SOURCES AS DESCRIBED IN THE ABOVE PARAGRAPH IS VOID AND OF NO EFFECT.</p> <p>BANKRUPTCY: IN THE EVENT THE VENDOR/CONTRACTOR FILES FOR BANKRUPTCY PROTECTION, THIS CONTRACT IS AUTOMATICALLY NULL AND VOID, AND IS TERMINATED WITHOUT FURTHER ORDER.</p> <p>REV. 1/2005</p> <p>NOTICE</p> <p>A SIGNED BID MUST BE SUBMITTED TO:</p> <p>DEPARTMENT OF ADMINISTRATION PURCHASING DIVISION</p>						

SEE REVERSE SIDE FOR TERMS AND CONDITIONS

SIGNATURE	TELEPHONE	DATE
LE	FEIN	ADDRESS CHANGES TO BE NOTED ABOVE

WHEN RESPONDING TO RFQ, INSERT NAME AND ADDRESS IN SPACE ABOVE LABELED 'VENDOR'



State of West Virginia
 Department of Administration
 Purchasing Division
 2019 Washington Street East
 Post Office Box 50130
 Charleston, WV 25305-0130

Request for Quotation

RFQ NUMBER
DCH09084

PAGE
9

ADDRESS CORRESPONDENCE TO ATTENTION OF
**SHELLY MURRAY
 304-558-8801**

VENDOR

RFQ COPY
 TYPE NAME/ADDRESS HERE

SUPPLIER

**DIVISION OF CULTURE & HISTORY
 CULTURAL CENTER
 1900 KANAWHA BOULEVARD, EAST
 CHARLESTON, WV
 25305-0300 558-0220**

DATE PRINTED	TERMS OF SALE	SHIP VIA	F.O.B	FREIGHT TERMS
04/01/2009				

BID OPENING DATE: **05/15/2009** **BID OPENING TIME 01:30PM**

LINE	QUANTITY	UOP	CAT NO	ITEM NUMBER	UNIT PRICE	AMOUNT
<p>BUILDING 15 2019 WASHINGTON STREET, EAST CHARLESTON, WV 25305-0130</p> <p>THE BID SHOULD CONTAIN THIS INFORMATION ON THE FACE OF THE ENVELOPE OR THE BID MAY NOT BE CONSIDERED:</p> <p>SEALED BID</p> <p>BUYER: SHELLY MURRAY</p> <p>REQ. NO.: DCH09084</p> <p>BID OPENING DATE: 05/15/2009</p> <p>BID OPENING TIME: 1:30 PM</p> <p>PLEASE PROVIDE A FAX NUMBER IN CASE IT IS NECESSARY TO CONTACT YOU REGARDING YOUR BID: ----- 304-746-4089 -----</p> <p>PLEASE PRINT OR TYPE NAME OF PERSON TO CONTACT CONCERNING THIS QUOTE: ----- Mark Murray -----</p>						

SEE REVERSE SIDE FOR TERMS AND CONDITIONS

SIGNATURE _____ TELEPHONE _____ DATE _____

TITLE _____ FEIN _____ ADDRESS CHANGES TO BE NOTED ABOVE

WHEN RESPONDING TO RFQ, INSERT NAME AND ADDRESS IN SPACE ABOVE LABELED 'VENDOR'



State of West Virginia
 Department of Administration
 Purchasing Division
 2019 Washington Street East
 Post Office Box 50130
 Charleston, WV 25305-0130

Request for Quotation

RFQ NUMBER
 DCH09084

PAGE
 1

ADDRESS CORRESPONDENCE TO ATTENTION OF:
 SHELLY MURRAY
 304-558-8801

VENDOR

*709001300 02 304-746-4081
 SIMPLEX GRINNELL
 2800 7TH AVE 102
 CHARLESTON WV 25312-1727

SHIP TO

DIVISION OF CULTURE & HISTORY
 CULTURAL CENTER
 1900 KANAWHA BOULEVARD, EAST
 CHARLESTON, WV
 25305-0300 558-0220

DATE PRINTED	TERMS OF SALE	SHIP VIA	F.O.B	FREIGHT TERMS
05/06/2009				

BID OPENING DATE: 05/20/2009 BID OPENING TIME 01:30PM

LINE	QUANTITY	UOP	CAT NO	ITEM NUMBER	UNIT PRICE	AMOUNT
----- ADDENDUM NO. 1 -----						
THIS ADDENDUM IS ISSUED TO ADDRESS QUESTIONS AND CONCERNS RAISED DURING THE MANDATORY PRE-BID CONFERENCE OF 04/21/2009 AND SUBMITTED PRIOR TO THE QUESTION SUBMISSION DEADLINE OF 04/28/2009.						
ATTACHMENTS: SPECIFICATION CLARIFICATIONS WITH QUESTIONS AND RESPONSES FORM OF PROPOSAL LIST OF PROPOSED SUBCONTRACTORS/SUPPLIERS DRAWINGS: A-1 AND A-2 PRE-BID SIGN IN SHEET						
THE BID OPENING DATE HAS BEEN EXTENDED:						
FROM: 05/15/2009 TO : 05/20/2009						
----- END OF ADDENDUM NO. 1 -----						
0001	1	LS		340-20		
FIRE ALARM/SPRINKLER UPGRADE						

SEE REVERSE SIDE FOR TERMS AND CONDITIONS

SIGNATURE	TELEPHONE	DATE
TITLE	FEIN	ADDRESS CHANGES TO BE NOTED ABOVE

WHEN RESPONDING TO RFQ, INSERT NAME AND ADDRESS IN SPACE ABOVE LABELED 'VENDOR'

GENERAL TERMS & CONDITIONS
REQUEST FOR QUOTATION (RFQ) AND REQUEST FOR PROPOSAL (RFP)

1. Awards will be made in the best interest of the State of West Virginia.
2. The State may accept or reject in part, or in whole, any bid.
3. All quotations are governed by the *West Virginia Code* and the *Legislative Rules* of the Purchasing Division.
4. Prior to any award, the apparent successful vendor must be properly registered with the Purchasing Division and have paid the required \$125 fee.
5. All services performed or goods delivered under State Purchase Order/Contracts are to be continued for the term of the Purchase Order/Contracts, contingent upon funds being appropriated by the Legislature or otherwise being made available. In the event funds are not appropriated or otherwise available for these services or goods, this Purchase Order/Contract becomes void and of no effect after June 30.
6. Payment may only be made after the delivery and acceptance of goods or services.
7. Interest may be paid for late payment in accordance with the *West Virginia Code*.
8. Vendor preference will be granted upon written request in accordance with the *West Virginia Code*.
9. The State of West Virginia is exempt from federal and state taxes and will not pay or reimburse such taxes.
10. The Director of Purchasing may cancel any Purchase Order/Contract upon 30 days written notice to the seller.
11. The laws of the State of West Virginia and the *Legislative Rules* of the Purchasing Division shall govern all rights and duties under the Contract, including without limitation the validity of this Purchase Order/Contract.
12. Any reference to automatic renewal is hereby deleted. The Contract may be renewed only upon mutual written agreement of the parties.
13. **BANKRUPTCY:** In the event the vendor/contractor files for bankruptcy protection, this Contract may be deemed null and void, and terminated without further order.
14. **HIPAA BUSINESS ASSOCIATE ADDENDUM:** The West Virginia State Government HIPAA Business Associate Addendum (BAA), approved by the Attorney General, and available online at the Purchasing Division's web site (<http://www.state.wv.us/admin/purchase/vrc/hipaa.htm>) is hereby made part of the agreement. Provided that, the Agency meets the definition of a Cover Entity (45 CFR §160.103) and will be disclosing Protected Health Information (45 CFR §160.103) to the vendor.
15. **WEST VIRGINIA ALCOHOL & DRUG-FREE WORKPLACE ACT:** If this Contract constitutes a public improvement construction contract as set forth in Article 1D, Chapter 21 of the West Virginia Code ("The West Virginia Alcohol and Drug-Free Workplace Act"), then the following language shall hereby become part of this Contract: "The contractor and its subcontractors shall implement and maintain a written drug-free workplace policy in compliance with the West Virginia Alcohol and Drug-Free Workplace Act, as set forth in Article 1D, Chapter 21 of the West Virginia Code. The contractor and its subcontractors shall provide a sworn statement in writing, under the penalties of perjury, that they maintain a valid drug-free work place policy in compliance with the West Virginia and Drug-Free Workplace Act. It is understood and agreed that this Contract shall be cancelled by the awarding authority if the Contractor: 1) Fails to implement its drug-free workplace policy; 2) Fails to provide information regarding implementation of the contractor's drug-free workplace policy at the request of the public authority; or 3) Provides to the public authority false information regarding the contractor's drug-free workplace policy."

INSTRUCTIONS TO BIDDERS

1. Use the quotation forms provided by the Purchasing Division.
2. **SPECIFICATIONS:** Items offered must be in compliance with the specifications. Any deviation from the specifications must be clearly indicated by the bidder. Alternates offered by the bidder as **EQUAL** to the specifications must be clearly defined. A bidder offering an alternate should attach complete specifications and literature to the bid. The Purchasing Division may waive minor deviations to specifications.
3. Complete all sections of the quotation form.
4. Unit prices shall prevail in case of discrepancy.
5. All quotations are considered F.O.B. destination unless alternate shipping terms are clearly identified in the quotation.
6. **BID SUBMISSION:** All quotations must be delivered by the bidder to the office listed below prior to the date and time of the bid opening. Failure of the bidder to deliver the quotations on time will result in bid disqualifications: Department of Administration, Purchasing Division, 2019 Washington Street East, P.O. Box 50130, Charleston, WV 25305-0130

DCH09084
Addendum No. 1

A. SPECIFICATIONS:

1. **Specification Section 00120 Form of Proposal:**
 - a. **ADD** this specification section to the bid documents and bound specifications dated March 11, 2009.
 - b. **PROVIDE** "Deduct Alternate". The contractor shall provide a "Deduct Alternate" for not performing the work in rooms #253 & #255 as follows:
 - 1) Demolition work per plan notes 1 & 2 on Dwg. D1.
 - 2) Ceiling, lighting etc. Work per plan notes 1 through 5 on Dwg. FA1.
2. **INSERT** attached "List of Proposed subcontractors equipment/ material suppliers", that should be submitted with bid.

B. DRAWINGS:

1. Sketches "A1 and A2": ZDS received drawings dated 4/14/09 for an area of renovations that will have a minor impact on this project. See attached sketches to this addendum.
2. The successful bidder on this project will be responsible for coordination of the Fire Alarm and Fire Protection Sprinkler work in the renovated area. Any modifications required for complete and operable systems will be included in this Contractor's Bid at no additional cost to the Owner.

B. QUESTIONS AND ANSWERS:

1. **Question:** Would our proposal be limited to the fire alarm devices shown on the drawings or could we propose an alternate installation that serves the same intent?
Answer: Proposal shall be based on the system as indicated on the drawings and in the specifications.
2. **Question:** Could we use factory painted red conduit in lieu of the red color banding added to standard grey conduit as mentioned in specification #16050, 3.6 D?
Answer: Yes

3. **Question:** In room #201 where existing ceiling is noted to be removed, the existing shelves, built outs, and furniture has to be removed to allow better access to the ceilings. Could indoor man-lifts gain access into these areas?

Answer: Existing shelving is built-in and cannot be removed. The loose furniture will be moved by the Cultural Center staff. Man-lifts may be used in these areas; Contractor is responsible for protection of the floor; any damages to the floor, etc, as a result of Contractor's work shall be repaired or replaced at the satisfaction of the Owner at no additional cost to the Owner.

4. **Question:** In areas of the 3rd and 4th floor where materials are stacked all the way to the ceiling, we will need to temporarily move limited amounts of material for conduit and pipe installation. Would moving items temporarily be a critical process to the owner/ operator? How would that affect the contractor?

Answer: In-house staff will move this material; however the contractor shall identify to the Cultural Center staff what needs to be moved.

5. **Question:** Is there a freight elevator with removable top panel available for moving long pipes and conduits to the upper levels?

Answer: There is no freight elevator available with removable panel; however, there is a path to get to these areas.

6. **Question:** Will parking be made available?

Answer: Yes. Limited parking will be made available to the contractor's superintendent and necessary supply vehicles. Individual workers will need to make other arrangements. This issue will be addressed in more detail during the pre-construction meeting.

7. **Question:** Please confirm that sprinkler piping does not get painted in the non public spaces i.e. 3rd and 4th level archive storage areas. The piping in the basement was not painted in non-public areas.

Answer: Painting of sprinkler piping will not be required in non-public spaces.

8. **Question:** Please refer to detail section A-A on sheets FP4 and FP5. This detail shows sprinkler piping running in the aisle space of the shelf storage areas. The detail shows a pendant sprinkler head. Please note that sprinklers cannot be installed in the pendant position on a Pre-Action System unless the sprinkler is on a return bend which cannot be done due to space issues. The sprinklers in these areas must be upright on top of the piping. The sprinkler deflectors can be installed as close as 1" to the deck and the centerline of the piping will be approximately 12" from the deck. It appears that in some cases the upper level of storage will be difficult to access. Please note that Pre-Action piping must be installed with proper pitch to drain.

Answer: On drawings FP3 and FP4, Detail section "A-A" shows pendent mounted heads. Sprinkler heads in these areas **must be** upright type. Note that all piping must be installed with proper pitch to drain.

9. **Question:** Please confirm that sprinkler heads are needed in the soffits located in rooms 201 and 252. These rooms can be found on sheet FP2. It appears that these soffits create obstructions to the overhead sprinklers. It looks like the piping can be run on top of the soffits and penetrate the soffits as necessary to provide proper protection.

Answer: Drawing FP2: In rooms #201 and #252 provide coverage as needed where soffits obstruct the overhead sprinklers. Piping can be routed on top of the soffits with penetrations to below for proper protection.

10. **Question:** Please confirm that you want Pre-Action for the 2nd floor in the south west office areas. This similar office area on the north side is shown as wet piping.

Answer: The second floor southwest office areas will be provided, as shown, with pre-action system as requested by Owner.

11. **Question:** There is not a smoke detector shown in vestibule 300 on the south side. You will need a smoke detector in this area to operate the Pre-Action system.

Answer: Drawing FA2: Add one (1) smoke detector in alcove #300 for the pre-action system.

E. MISCELLANEOUS:

1. Existing items, surfaces to remain that are damaged during the work of this Contractor shall be replaced, repaired or refinished to the satisfaction of the Owner at no additional cost to the Owner.
2. Loose furnishings, materials etc. that require moving for the work shall be coordinated with the Owner at least 24 hours in advance. Owners' personnel shall move these items.

Total pages for Addendum One is 3 pages.

Enclosed:

Form of Proposal – 4 pages

List of Proposed Subcontractors Equipment/ Material Suppliers Form – 2 pages

Sketches "A1" & "A2" – 2 pages

FORM OF PROPOSAL

OWNER: West Virginia Division of Culture & History
Charleston, WV

PROJECT: Cultural Center: Fire Alarm/ Sprinkler Upgrades, Charleston, WV

The undersigned, hereinafter called the Bidder, being familiar with and understanding the Bidding Documents and also having examined the site and being familiar with all local conditions affecting the Project, hereby proposes to furnish all labor, material, equipment, supplies and transportation, and to perform all Work in accordance with the Bidding Documents for the sum of:

BASE BID: _____

_____ \$ _____
(Bid amount shall be shown in both words and numbers. In the event of a difference between the written amount and the number amount, the written amount shall prevail.)

ALTERNATE #1: DEDUCT _____

_____ \$ _____
(Note that the Alternate Deduct price is included in the Base Bid amount.)

UNIT PRICES: FOR FURTHER DETAILS REFER TO SPECIFICATIONS

- Item No. 1 – Pull Station Each \$ _____
- Item No. 2 – Strobe Each \$ _____
- Item No. 3 – Speaker Strobe Each \$ _____
- Item No. 4 – Combination Heat Detector Each \$ _____
- Item No. 5 – Smoke Detector Each \$ _____
- Item No. 6 – Flow or Tamper Switch Connector Each \$ _____
- Item No. 7 – One Control Relay Each \$ _____
- Item No. 8 – Duct Smoke Detector Each \$ _____
- Item No. 9 – Monitor Module Each \$ _____

RESPECTFULLY SUBMITTED:

SIGNATURE: _____ DATE: _____

NAME: _____

FIRMNAME: _____

FIRM ADDRESS: _____ *Corporate Seal
If Applicable*

TELEPHONE: _____

CONTRACT TIME: _____

Contractor's License Number: _____

The successful Bidding Contractor agrees that from the compensation otherwise to be paid, the Owner may retain a sum in accordance with the following schedule for each day thereafter, Sundays and holidays included, that the work remains uncompleted, which sum is agreed upon as the proper measure of liquidated damages which the Owner will sustain per diem by the failure of the contractor to complete the work at the stipulated time, and the sum is not to be construed in any sense a penalty. The successful Bidder also shall pay any additional fees that the Engineer and the Engineer's consultants may accrue.

LIQUIDATED DAMAGES WILL BE ASSESSED AS FOLLOWS:

\$750.00/per day

The Owner will suffer financial loss if the Work is not Substantially Complete within the Contract Time. Allowance may be made for delays due to shortages of materials and/or energy resources, subject to proof by documentation, and also for delays due to strikes or other delays beyond the control of the Contractor. All delays and any claim for extension of the Contract Time must be properly documented in accordance with the Contract Documents by the Contractor and approved by the Engineer/Owner.

AUTHORITY AND RESPONSIBILITY OF THE ENGINEER:

The Engineer shall decide any and all questions that may arise as to the quality and acceptability of materials furnished, work performed, rate of progress of work, interpretation of drawings and specifications and all questions as to the acceptable fulfillment of the contract on the part of the contractor.

SUCCESSORS AND ASSIGNS:

This Agreement and all of the covenants hereof shall inure to the benefit of and be binding upon the Owner and the Contractor respectively and his partners, successors, assigns and legal representatives. Neither the Owner nor the Contractor shall have the right to assign, transfer or sublet his interests or obligations hereunder without consent of the other party.

PREBID MEETING IS MANDATORY

Mandatory attendance is required for all Bidders at the Pre-bid Meeting to familiarize themselves with the Project location, site conditions and other relevant information. Any Bidder who fails to attend the Pre-bid Meeting will cause that Bid to be disqualified.

ADDENDA ACKNOWLEDGMENT

The undersigned hereby acknowledges receipt of the following Addenda and has taken the information contained therein into full consideration in the formulation of this bid.

- Addenda No. 1 _____
- Addenda No. 2 _____
- Addenda No. 3 _____
- Addenda No. 4 _____
- Addenda No. 5 _____

Failure to acknowledge receipt of each Addendum may be cause for rejection of the bid.

SIGNATURE: _____
Signature in Ink

DATE: _____

BIDDER'S CERTIFICATION

The Bidder hereby acknowledges that the following representations in this Proposal are material and not mere recitals:

1. Bidder has read and understands the Contract Documents and agrees to comply with all requirements of the Contract Documents, regardless of whether the Bidder has actual knowledge of the requirements and regardless of any statement or omission made by the Bidder, which might indicate a contrary intention.
2. The Bidder represents that the Proposal is based upon the Standards specified by the Contract Documents.
3. Bidder has visited the site, has become familiar with local conditions and has correlated personal observations about the requirements of the Contract Documents. The Bidder has no outstanding questions regarding the interpretation of the Contract Documents.
4. The Bidder shall make a good faith effort to ensure that all the Bidder employees, while working on Owner's property, shall not purchase, transfer, use or possess tobacco products, illegal drugs, alcohol, abuse prescription drugs in any way.
5. Bidder agrees to furnish any information requested by the Owner/Engineer to evaluate the responsibility of the Bidder.
6. The Bidder and each person signing on behalf of the Bidder certifies, and in the case of a joint Proposal, each party thereto certifies as to such party's organization, under penalty of perjury, that to the best of the undersigned's knowledge and belief:
 - 6.1 The Proposal has been prepared independently without collusion, consultation, communication or agreement, for the purpose of restricting competition as to any matter relating to such Proposal.
 - 6.2 Unless otherwise required by law, the costs, which have been quoted in the Proposal, have not been knowingly disclosed by the Bidder and will not knowingly be disclosed by the Bidder prior to the Proposal deadline, directly or indirectly, to any other Bidder that would have any interest in the Proposal costs.
 - 6.3 No attempt has been made or will be made by the Bidder to induce any other individual, partnership or corporation to submit or not to submit a Proposal for the purpose of restricting competition.

The successful bidder will be required to furnish a copy of their Contractor's License prior to issuance of a Purchase Order/Contract.

END OF SECTION 00120

LIST OF PROPOSED SUBCONTRACTORS EQUIPMENT / MATERIAL SUPPLIERS

(This form must be included in bid or faxed to the OWNER/ENGINEER within two hours of close of bid)

List below each major branch of work and major equipment / material category for this proposal and the subcontractor or supplier proposed for that portion of work; also provide the contractor's license number for each subcontractor as required by the "West Virginia Contractor Licensing Act." If the branch of work is to be completed solely by an equipment / material supplier, indicate by notation below in the contractor license number column. The bidder may be requested to change an unsatisfactory subcontractor or equipment / material supplier. The contractor is responsible for selecting or changing subcontractor or equipment / material supplier. The Owner or Engineer may indicate their concerns about any entity listed which they have reason to believe past experience indicates poor performance may be expected. It is the responsibility of any contractor soliciting bids or quotes from subcontractors to verify the eligibility of all proposed subcontractors and equipment / material suppliers being proposed to perform the work. The Contractor has full responsibility for satisfactory execution of all work in accordance with the contract documents. Any change of proposed subcontractors or material suppliers shall be at no additional cost to Owner, as the Contractor has full responsibility for execution of the work.

I _____ representing _____
 (Signature of Responsible Contractor) (Company Name)
 on this date _____ submit the following list of subcontractors and major material suppliers for your review and comment. This is the final and complete list of companies who will be performing work or supplying materials for **CULTURAL CENTER FIRE ALARM/SPRINKLER UPGRADES**.

I agree that once the subcontractors and material suppliers listed are approved for use by the Owner and Engineer, no other subcontractors or substitute for any subcontractors listed below, will be used in the performance of the contract without written approval of the Owner and Engineer. I further agree that if non-approved subcontractors or suppliers are used, my company shall be placed on probation, unless in its reasonable discretion, the STATE OF WV determines otherwise.

LIST OF PROPOSED SUBCONTRACTORS EQUIPMENT / MATERIAL SUPPLIERS

(This form must be included in bid of faxed to the OWNER/ENGINEER within two hours of close of bid)

Branch of work / Material Category	Complete Name and Address Subcontractor (to be completed by	Complete Name and Address Supplier Contractor)	Contractor License #
SPRINKLER			
Sprinkler Contractor			
ELECTRICAL			
Electrical Contractor			
Fire Alarm			
GENERAL CONSTRUCTION			
General Trades Contractor			

DOOR SCHEDULE

NO.	SYMBOL	TYPE	FINISH	FRM.	GLASS	HT.	W.D.	FIN.	GLASS	HT.	W.D.
1		6-0 x 2-0	1-1/2"	0-10"	0-10"	6-0"	2-0"	0-10"	0-10"	6-0"	2-0"
2		6-0 x 2-0	1-1/2"	0-10"	0-10"	6-0"	2-0"	0-10"	0-10"	6-0"	2-0"
3		6-0 x 2-0	1-1/2"	0-10"	0-10"	6-0"	2-0"	0-10"	0-10"	6-0"	2-0"
4		6-0 x 2-0	1-1/2"	0-10"	0-10"	6-0"	2-0"	0-10"	0-10"	6-0"	2-0"

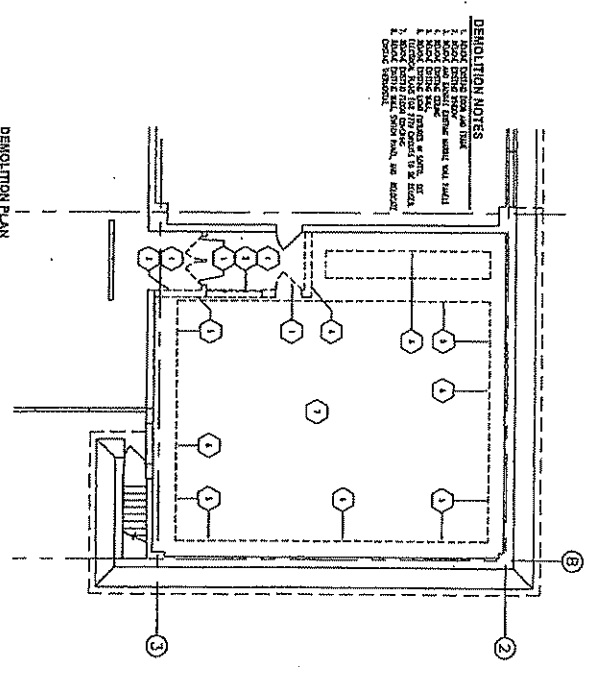
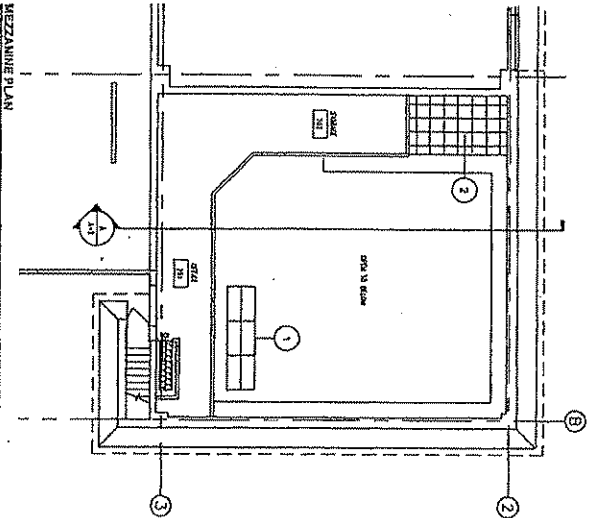
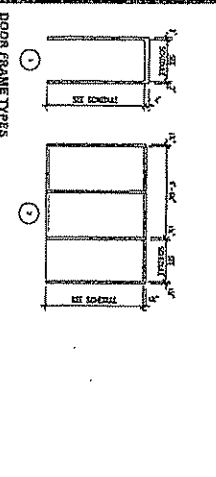
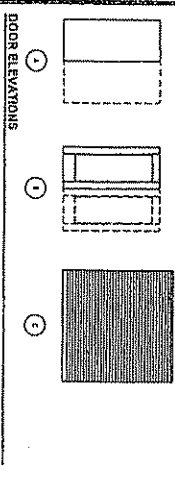

TOILET ACCESSORIES SCHEDULE

SYMBOL	DESCRIPTION	MODEL NUMBER	MANUFACTURER	FINISH	NOTES
1	30" WIDE	6-0285	J.A. FRANK	STAINLESS STEEL	1-1/2" FLOOR FINISH
2	12" HIGH	6-0285	J.A. FRANK	STAINLESS STEEL	1-1/2" FLOOR FINISH
3	18" HIGH	6-0285	J.A. FRANK	STAINLESS STEEL	1-1/2" FLOOR FINISH
4	24" HIGH	6-0285	J.A. FRANK	STAINLESS STEEL	1-1/2" FLOOR FINISH
5	30" HIGH	6-0285	J.A. FRANK	STAINLESS STEEL	1-1/2" FLOOR FINISH
6	36" HIGH	6-0285	J.A. FRANK	STAINLESS STEEL	1-1/2" FLOOR FINISH
7	42" HIGH	6-0285	J.A. FRANK	STAINLESS STEEL	1-1/2" FLOOR FINISH
8	48" HIGH	6-0285	J.A. FRANK	STAINLESS STEEL	1-1/2" FLOOR FINISH
9	54" HIGH	6-0285	J.A. FRANK	STAINLESS STEEL	1-1/2" FLOOR FINISH
10	60" HIGH	6-0285	J.A. FRANK	STAINLESS STEEL	1-1/2" FLOOR FINISH

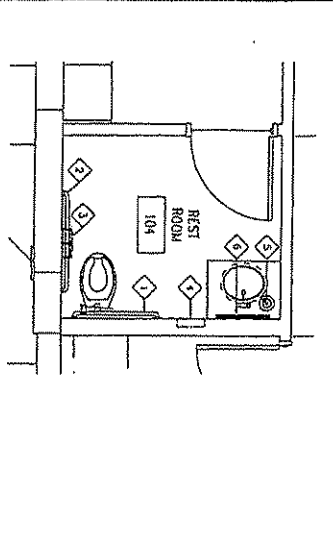

KEYED NOTES

1. "MATERIAL" SHALL BE SUBJECT TO APPROVAL. SHALL BE STAINLESS STEEL, 16 GA. THICK AND FINISH TO MATCH EXISTING MATERIALS. SHALL BE STAINLESS STEEL, 16 GA. THICK AND FINISH TO MATCH EXISTING MATERIALS.
2. "MANUFACTURER" SHALL BE SUBJECT TO APPROVAL. SHALL BE J.A. FRANK, MODEL NO. 6-0285.
3. "FINISH" SHALL BE SUBJECT TO APPROVAL. SHALL BE STAINLESS STEEL, 16 GA. THICK AND FINISH TO MATCH EXISTING MATERIALS.
4. "HEIGHT" SHALL BE SUBJECT TO APPROVAL. SHALL BE 30" HIGH.
5. "WIDTH" SHALL BE SUBJECT TO APPROVAL. SHALL BE 30" WIDE.
6. "DEPTH" SHALL BE SUBJECT TO APPROVAL. SHALL BE 24" DEEP.
7. "LOCATION" SHALL BE SUBJECT TO APPROVAL. SHALL BE AS SHOWN ON THIS PLAN.
8. "ALIGNMENT" SHALL BE SUBJECT TO APPROVAL. SHALL BE AS SHOWN ON THIS PLAN.
9. "FINISH" SHALL BE SUBJECT TO APPROVAL. SHALL BE STAINLESS STEEL, 16 GA. THICK AND FINISH TO MATCH EXISTING MATERIALS.
10. "HEIGHT" SHALL BE SUBJECT TO APPROVAL. SHALL BE 30" HIGH.
11. "WIDTH" SHALL BE SUBJECT TO APPROVAL. SHALL BE 30" WIDE.
12. "DEPTH" SHALL BE SUBJECT TO APPROVAL. SHALL BE 24" DEEP.
13. "LOCATION" SHALL BE SUBJECT TO APPROVAL. SHALL BE AS SHOWN ON THIS PLAN.
14. "ALIGNMENT" SHALL BE SUBJECT TO APPROVAL. SHALL BE AS SHOWN ON THIS PLAN.
15. "FINISH" SHALL BE SUBJECT TO APPROVAL. SHALL BE STAINLESS STEEL, 16 GA. THICK AND FINISH TO MATCH EXISTING MATERIALS.
16. "HEIGHT" SHALL BE SUBJECT TO APPROVAL. SHALL BE 30" HIGH.
17. "WIDTH" SHALL BE SUBJECT TO APPROVAL. SHALL BE 30" WIDE.
18. "DEPTH" SHALL BE SUBJECT TO APPROVAL. SHALL BE 24" DEEP.
19. "LOCATION" SHALL BE SUBJECT TO APPROVAL. SHALL BE AS SHOWN ON THIS PLAN.
20. "ALIGNMENT" SHALL BE SUBJECT TO APPROVAL. SHALL BE AS SHOWN ON THIS PLAN.

ROOM FINISH SCHEDULE

NO.	SYMBOL	DESCRIPTION	MANUFACTURER	FINISH	NOTES
1		PAINTED CONCRETE	PPG INDUSTRIES	PPG PREGLO	AS SHOWN
2		PAINTED CONCRETE	PPG INDUSTRIES	PPG PREGLO	AS SHOWN
3		PAINTED CONCRETE	PPG INDUSTRIES	PPG PREGLO	AS SHOWN
4		PAINTED CONCRETE	PPG INDUSTRIES	PPG PREGLO	AS SHOWN
5		PAINTED CONCRETE	PPG INDUSTRIES	PPG PREGLO	AS SHOWN
6		PAINTED CONCRETE	PPG INDUSTRIES	PPG PREGLO	AS SHOWN
7		PAINTED CONCRETE	PPG INDUSTRIES	PPG PREGLO	AS SHOWN
8		PAINTED CONCRETE	PPG INDUSTRIES	PPG PREGLO	AS SHOWN
9		PAINTED CONCRETE	PPG INDUSTRIES	PPG PREGLO	AS SHOWN
10		PAINTED CONCRETE	PPG INDUSTRIES	PPG PREGLO	AS SHOWN

GENERAL NOTES

1. SHALL BE SUBJECT TO APPROVAL.
2. SHALL BE SUBJECT TO APPROVAL.
3. SHALL BE SUBJECT TO APPROVAL.
4. SHALL BE SUBJECT TO APPROVAL.
5. SHALL BE SUBJECT TO APPROVAL.
6. SHALL BE SUBJECT TO APPROVAL.
7. SHALL BE SUBJECT TO APPROVAL.
8. SHALL BE SUBJECT TO APPROVAL.
9. SHALL BE SUBJECT TO APPROVAL.
10. SHALL BE SUBJECT TO APPROVAL.

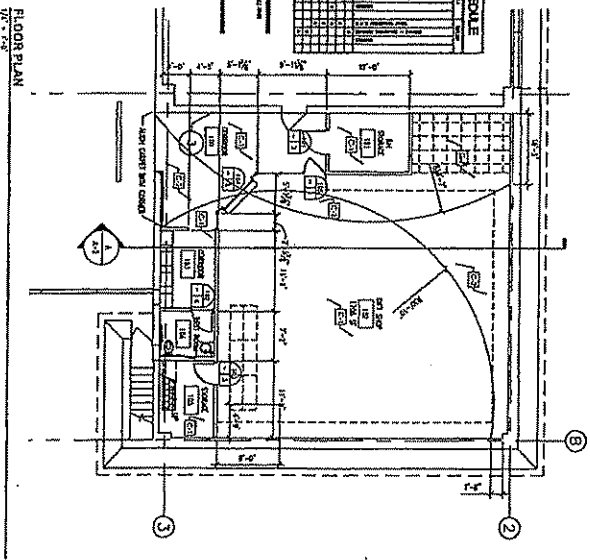

A-1	<p>Renovations for the STATE MUSEUM SHOP WEST VIRGINIA CULTURAL CENTER Charleston, West Virginia</p> <p>Construction Documents</p>	<p>221 East 35th Street Charleston, West Virginia 25302 Phone: 336-4222 Fax: 336-4221 WWW.ZMM.COM</p> <p>ZMM ARCHITECTS & ENGINEERS</p>	<table border="1" style="width: 100%; border-collapse: collapse;"> <thead> <tr> <th style="width: 5%;">NO.</th> <th style="width: 15%;">DATE</th> <th style="width: 80%;">DESCRIPTION</th> </tr> </thead> <tbody> <tr><td> </td><td> </td><td> </td></tr> <tr><td> </td><td> </td><td> </td></tr> <tr><td> </td><td> </td><td> </td></tr> </tbody> </table>	NO.	DATE	DESCRIPTION									
NO.	DATE	DESCRIPTION													
<p>DATE: 08/21/14 DRAWN BY: SRS CHECKED BY: SRS DATE: 08/21/14 COUNCIL NO. 5445</p>	<p>DEMOLITION PLAN FLOOR PLANS SCHEDULES</p> <p>DATE: 08/21/14</p>														

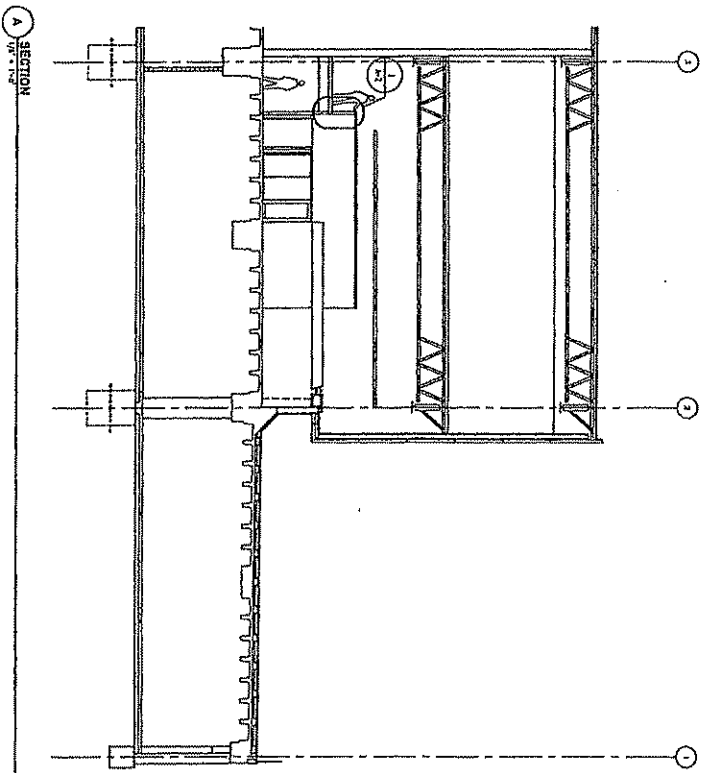
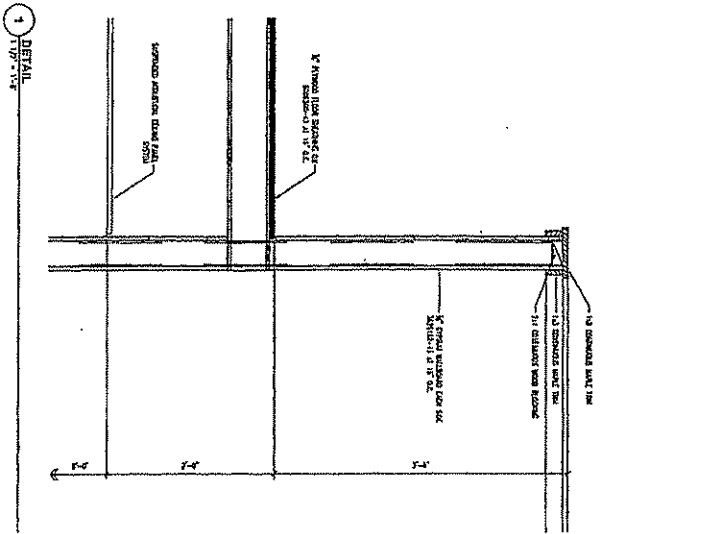

A-2

DESIGNED BY	DATE
CHECKED BY	DATE
SCALE	BY
COUNT. NO.	NO.

DR. JIM, INC.

**Renovations for the
STATE MUSEUM SHOP
WEST VIRGINIA CULTURAL CENTER
Charleston, West Virginia**

Construction Documents

ZMM
ARCHITECTS & ENGINEERS

2215 3rd St. West
Charleston, West Virginia 25302
Phone: 304.262.0100
Fax: 304.262.1700
www.zmm.com

REVISIONS NO.	DATE	DESCRIPTION

3/20/2011

Pre-Bid Conference
SIGN IN SHEET

[Please Print]

Request for Proposal No.: 204 09084 Date: 4/21/09

<u>Firm & Representative Name</u>	<u>Mailing Address</u>	<u>Telephone & FAX Numbers</u>
1. <u>SIMPSON TECHNICAL SERV.</u> <u>MARK SIMPSON</u>	<u>519 HIGHLAND AVE.</u> <u>So. CHAR., WV. 25303</u>	T: <u>304-437-1913</u> F: <u>304-744-5829</u>
2. <u>BREWER & COMPANY</u> <u>DOUG MEEKS</u>	<u>P.O. Box 3108</u> <u>CHARLESTON, WV</u>	T: <u>304-744-5314</u> F: <u>304-744-4879</u>
3. <u>E+M Products Inc</u> <u>Jag Hinte</u>	<u>416 12th St.</u> <u>Dunbar, WV 25064</u>	T: <u>(304)768-1673</u> F: <u>(304)768-1674</u>
4. <u>TEOT. ZACHWIEJP</u> <u>ZDS DESIGN</u>	<u>21 Dunbar Drive</u> <u>ST. ALBANS, WV 25311</u>	T: <u>304-755-0075</u> F: <u>304-755-0076</u>
5. <u>Jason Caplinger</u> <u>Summit Electric</u>	<u>P.O. Box 234</u> <u>Hurricane WV 25626</u>	T: <u>304-862-7091</u> F: <u>304-862-7137</u>
6. <u>Sean C. Givens</u> <u>Simplex Grinnell</u>	<u>2800 7th Avenue Suite 102</u> <u>Charleston WV 25312</u>	T: <u>304-746-9081</u> F: <u>304-746-9089</u>
7. <u>Don KAWA</u> <u>Simplex Grinnell</u>	<u>2800 7th Avenue Suite 102</u> <u>Charleston WV 25312</u>	T: <u>513-678-9046</u> F: <u>513-874-1246</u>
8. <u>Brown Electric</u> <u>Branson Kennedy</u>	<u>1100 Charles Ave.</u> <u>Dunbar WV 25064</u>	T: <u>304 768-0407</u> F: <u>304 768-0426</u>
9. <u>Pritchard Electric</u> <u>Jerry Grubbs</u>	<u>2425 8th Avenue</u> <u>Huntington WV 25703</u>	T: <u>304-529-2566 X19</u> F: <u>304-529-2567</u>
10. <u>APPALACHIAN SIGNALS & PRODUCTS</u> <u>KENNETH WALTERS III</u>	<u>PO Box 508</u> <u>WINFIELD, WV 25213</u>	T: <u>304-586-2913</u> F: <u>304-586-2914</u>

Please print or write legibly. The fax number is essential to contact the attendees in a timely manner.

Pre-Bid Conference
SIGN IN SHEET

[Please Print]

Request for Proposal No.: DCH09084 Date: 4/21/09

Firm & Representative Name

Mailing Address

Telephone & FAX Numbers

1. Brian Dixon
Electronic Specialty

1325 Dunbar Ave
Dunbar WV

T: 304-766-6277
F: 304-766-6270

2. BRIAN THOMAS
PROGRESSIVE ELECTRIC

1019 York
ST CHARLES

T: 345-1253
F: 345-1256

3. _____

T: _____
F: _____

4. _____

T: _____
F: _____

5. _____

T: _____
F: _____

6. _____

T: _____
F: _____

7. _____

T: _____
F: _____

8. _____

T: _____
F: _____

9. _____

T: _____
F: _____

10. _____

T: _____
F: _____

Please print or write legibly. The fax number is essential to contact the attendees in a timely manner.