



State of West Virginia
 Department of Administration
 Purchasing Division
 2019 Washington Street East
 Post Office Box 50130
 Charleston, WV 25305-0130

Request for Quotation

RFQ NUMBER
 DCH09029

PAGE
 1

ADDRESS CORRESPONDENCE TO ATTENTION OF:
 SHELLY MURRAY
 304-558-8801

VENDOR

ERB Electric
500 Hall Street
Bridgeport, OH 43912

SHIP TO

DIVISION OF CULTURE & HISTORY
 GRAVE CREEK ARCHEOLOGY COMPLEX
 801 JEFFERSON AVENUE
 PO BOX 527
 MOUNDSVILLE, WV
 26041 304-558-0220

DATE PRINTED	TERMS OF SALE	SHIP VIA	F.O.B.	FREIGHT TERMS
09/05/2008				

BID OPENING DATE: 10/09/2008 BID OPENING TIME 01:30PM

LINE	QUANTITY	UOP	CAT NO.	ITEM NUMBER	UNIT PRICE	AMOUNT
------	----------	-----	---------	-------------	------------	--------

THE WV PURCHASING DIVISION, FOR THE AGENCY, THE WV DIVISION OF CULTURE AND HISTORY, IS SOLICITING BIDS FOR A CONTRACT TO PROVIDE THE AGENCY WITH A REPLACEMENT GENERATOR SYSTEM AND PERIPHERALS AND INSTALLATION AT THEIR GRAVE CREEK ARCHEOLOGY COMPLEX LOCATED IN MOUNDSVILLE, WV.

ATTACHMENTS: SPECIFICATIONS
 PURCHASING AFFIDAVIT
 DRAWING

INQUIRIES:
 WRITTEN QUESTIONS SHALL BE ACCEPTED THROUGH CLOSE OF BUSINESS ON 9/25/2008. QUESTIONS MAY BE SENT VIA USPS, FAX, COURIER, OR EMAIL. IN ORDER TO ASSURE NO VENDOR RECEIVES AN UNFAIR ADVANTAGE, NO SUBSTANTIVE QUESTIONS WILL BE ANSWERED ORALLY. IF POSSIBLE, EMAIL QUESTIONS ARE PREFERRED. ADDRESS INQUIRES TO:

SHELLY MURRAY
 DEPARTMENT OF ADMINISTRATION
 PURCHASING DIVISION
 2019 WASHINGTON STREET EAST
 CHARLESTON, WV 25311
 FAX: 304-558-4115
 EMAIL: SHELLY.L.MURRAY@WV.GOV

RECEIVED

08 OCT 27 PM 12:27

PURCHASING DIVISION
 STATE OF WV

0001	1	LS		285-39		
GENERATOR SYSTEM						

SEE REVERSE SIDE FOR TERMS AND CONDITIONS

SIGNATURE	TELEPHONE	DATE
TITLE	FEIN	ADDRESS CHANGES TO BE NOTED ABOVE

WHEN RESPONDING TO RFQ, INSERT NAME AND ADDRESS IN SPACE ABOVE LABELED 'VENDOR'

**GENERAL TERMS & CONDITIONS
REQUEST FOR QUOTATION (RFQ) AND REQUEST FOR PROPOSAL (RFP)**

1. Awards will be made in the best interest of the State of West Virginia.
2. The State may accept or reject in part, or in whole, any bid.
3. All quotations are governed by the *West Virginia Code* and the *Legislative Rules* of the Purchasing Division.
4. Prior to any award, the apparent successful vendor must be properly registered with the Purchasing Division and have paid the required \$125 fee.
5. All services performed or goods delivered under State Purchase Order/Contracts are to be continued for the term of the Purchase Order/Contracts, contingent upon funds being appropriated by the Legislature or otherwise being made available. In the event funds are not appropriated or otherwise available for these services or goods, this Purchase Order/Contract becomes void and of no effect after June 30.
6. Payment may only be made after the delivery and acceptance of goods or services.
7. Interest may be paid for late payment in accordance with the *West Virginia Code*.
8. Vendor preference will be granted upon written request in accordance with the *West Virginia Code*.
9. The State of West Virginia is exempt from federal and state taxes and will not pay or reimburse such taxes.
10. The Director of Purchasing may cancel any Purchase Order/Contract upon 30 days written notice to the seller.
11. The laws of the State of West Virginia and the *Legislative Rules* of the Purchasing Division shall govern all rights and duties under the Contract, including without limitation the validity of this Purchase Order/Contract.
12. Any reference to automatic renewal is hereby deleted. The Contract may be renewed only upon mutual written agreement of the parties.
13. **BANKRUPTCY:** In the event the vendor/contractor files for bankruptcy protection, this Contract may be deemed null and void, and terminated without further order.
14. **HIPAA BUSINESS ASSOCIATE ADDENDUM:** The West Virginia State Government HIPAA Business Associate Addendum (BAA), approved by the Attorney General, and available online at the Purchasing Division's web site (<http://www.state.wv.us/admin/purchase/vrc/hipaa.htm>) is hereby made part of the agreement. Provided that, the Agency meets the definition of a Cover Entity (45 CFR §160.103) and will be disclosing Protected Health Information (45 CFR §160.103) to the vendor.
15. **WEST VIRGINIA ALCOHOL & DRUG-FREE WORKPLACE ACT:** If this Contract constitutes a public improvement construction contract as set forth in Article 1D, Chapter 21 of the West Virginia Code ("The West Virginia Alcohol and Drug-Free Workplace Act"), then the following language shall hereby become part of this Contract: "The contractor and its subcontractors shall implement and maintain a written drug-free workplace policy in compliance with the West Virginia Alcohol and Drug-Free Workplace Act, as set forth in Article 1D, Chapter 21 of the West Virginia Code. The contractor and its subcontractors shall provide a sworn statement in writing, under the penalties of perjury, that they maintain a valid drug-free work place policy in compliance with the West Virginia and Drug-Free Workplace Act. It is understood and agreed that this Contract shall be cancelled by the awarding authority if the Contractor: 1) Fails to implement its drug-free workplace policy; 2) Fails to provide information regarding implementation of the contractor's drug-free workplace policy at the request of the public authority; or 3) Provides to the public authority false information regarding the contractor's drug-free workplace policy."

INSTRUCTIONS TO BIDDERS

1. Use the quotation forms provided by the Purchasing Division.
2. **SPECIFICATIONS:** Items offered must be in compliance with the specifications. Any deviation from the specifications must be clearly indicated by the bidder. Alternates offered by the bidder as **EQUAL** to the specifications must be clearly defined. A bidder offering an alternate should attach complete specifications and literature to the bid. The Purchasing Division may waive minor deviations to specifications.
3. Complete all sections of the quotation form.
4. Unit prices shall prevail in case of discrepancy.
5. All quotations are considered F.O.B. destination unless alternate shipping terms are clearly identified in the quotation.
6. **BID SUBMISSION:** All quotations must be delivered by the bidder to the office listed below prior to the date and time of the bid opening. Failure of the bidder to deliver the quotations on time will result in bid disqualifications: Department of Administration, Purchasing Division, 2019 Washington Street East, P.O. Box 50130, Charleston, WV 25305-0130



State of West Virginia
 Department of Administration
 Purchasing Division
 2019 Washington Street East
 Post Office Box 50130
 Charleston, WV 25305-0130

Request for Quotation

RFQ NUMBER
 DCH09029

PAGE
 2

ADDRESS CORRESPONDENCE TO ATTENTION OF:
 SHELLY MURRAY
 304-558-8801

RFQ COPY

TYPE NAME/ADDRESS HERE

VENDOR

SHIP TO

DIVISION OF CULTURE & HISTORY
 GRAVE CREEK ARCHEOLOGY COMPLEX
 801 JEFFERSON AVENUE
 PO BOX 527
 MOUNDSVILLE, WV
 26041 304-558-0220

DATE PRINTED	TERMS OF SALE	SHIP VIA	F.O.B.	FREIGHT TERMS
09/05/2008				

BID OPENING DATE: 10/09/2008 BID OPENING TIME 01:30PM

LINE	QUANTITY	UOP	CAT NO	ITEM NUMBER	UNIT PRICE	AMOUNT
<p>EXHIBIT 5</p> <p>NOTICE TO PROCEED: THIS CONTRACT IS TO BE PERFORMED WITHIN 120 CALENDAR DAYS AFTER THE NOTICE TO PROCEED IS RECEIVED. UNLESS OTHERWISE SPECIFIED, THE FULLY EXECUTED PURCHASE ORDER WILL BE CONSIDERED NOTICE TO PROCEED.</p> <p>CANCELLATION: THE DIRECTOR OF PURCHASING RESERVES THE RIGHT TO CANCEL THIS CONTRACT IMMEDIATELY UPON WRITTEN NOTICE TO THE VENDOR IF THE MATERIALS OR WORKMANSHIP SUPPLIED ARE OF AN INFERIOR QUALITY OR DO NOT CONFORM WITH THE SPECIFICATIONS OF THE BID AND CONTRACT HERE IN.</p> <p>WAGE RATES: THE CONTRACTOR OR SUBCONTRACTOR SHALL PAY THE HIGHER OF THE U.S. DEPARTMENT OF LABOR MINIMUM WAGE RATES AS ESTABLISHED FOR MARSHALL COUNTY, PURSUANT TO WEST VIRGINIA CODE 21-5A, ET, SEQ. (PREVAILING WAGE RATES APPLY TO THIS PROJECT)</p> <p>ARBITRATION: ANY REFERENCES MADE TO ARBITRATION OR INTEREST FOR PAYMENTS DUE (EXCEPT FOR ANY INTEREST REQUIRED BY STATE LAW) CONTAINED IN THIS CONTRACT OR IN ANY AMERICAN INSTITUTE OF ARCHITECTS DOCUMENTS PERTAINING TO THIS CONTRACT ARE HEREBY DELETED.</p> <p>WORKERS' COMPENSATION: VENDOR IS REQUIRED TO PROVIDE A CERTIFICATE FROM WORKERS' COMPENSATION IF SUCCESSFUL.</p> <p>ALL OF THE ITEMS CHECKED BELOW WILL BE A REQUIREMENT OF THIS CONTRACT:</p> <p>(XX) INSURANCE: SUCCESSFUL VENDOR SHALL FURNISH PROOF OF COMMERCIAL GENERAL LIABILITY INSURANCE PRIOR TO ISSUANCE OF CONTRACT. REVERSE SIDE FOR OTHERS AND CONDITIONS SPECIFIED IN</p>						

SIGNATURE	TELEPHONE	DATE
TITLE	FEIN	ADDRESS CHANGES TO BE NOTED ABOVE

WHEN RESPONDING TO RFQ, INSERT NAME AND ADDRESS IN SPACE ABOVE LABELED 'VENDOR'



State of West Virginia
 Department of Administration
 Purchasing Division
 2019 Washington Street East
 Post Office Box 50130
 Charleston, WV 25305-0130

Request for Quotation

RFQ NUMBER
 DCH09029

PAGE
 3

ADDRESS CORRESPONDENCE TO ATTENTION OF
 SHELLY MURRAY
 304-558-8801

RFQ COPY
 TYPE NAME/ADDRESS HERE

V
E
N
D
O
R

S
H
I
P
T
O

DIVISION OF CULTURE & HISTORY
 GRAVE CREEK ARCHEOLOGY COMPLEX
 801 JEFFERSON AVENUE
 PO BOX 527
 MOUNDSVILLE, WV
 26041 304-558-0220

DATE PRINTED	TERMS OF SALE	SHIP VIA	F.O.B.	FREIGHT TERMS
09/05/2008				

BID OPENING DATE: 10/09/2008 BID OPENING TIME 01:30PM

LINE	QUANTITY	UOP	CAT NO	ITEM NUMBER	UNIT PRICE	AMOUNT
<p>THE BID DOCUMENTS, THE MINIMUM AMOUNT OF INSURANCE COVERAGE REQUIRED IS \$250,000.</p> <p>() BUILDERS RISK INSURANCE: SUCCESSFUL VENDOR SHALL FURNISH PROOF OF BUILDERS RISK - ALL RISK INSURANCE IN AN AMOUNT EQUAL TO 100% OF THE AMOUNT OF THE CONTRACT.</p> <p>(XX) BONDS: FIVE PERCENT (5%) OF THE TOTAL AMOUNT OF THE BID PAYABLE TO THE STATE OF WEST VIRGINIA, SHALL BE SUBMITTED WITH EACH BID AS A BID BOND. THE SUCCESSFUL BIDDER SHALL ALSO FURNISH A PERFORMANCE BOND AND LABOR/MATERIAL BOND FOR 100% OF THE AMOUNT OF THE CONTRACT. BONDS MAY BE PROVIDED IN THE FORM OF A CERTIFIED CHECK, IRREVOCABLE LETTER OF CREDIT, OR BOND FURNISHED BY A SOLVENT SURETY COMPANY AUTHORIZED TO DO BUSINESS IN THE STATE OF WEST VIRGINIA. A LETTER OF CREDIT SUBMITTED IN LIEU OF A BOND WILL ONLY BE ALLOWED FOR PROJECTS UNDER \$100,000. PERSONAL OR BUSINESS CHECKS ARE NOT ACCEPCTABLE IN LIEU OF THE 5% BID BOND, PERFORMANCE BOND, OR LABOR AND MATERIAL BOND.</p> <p>() MAINTENANCE BOND: A TWO (2) YEAR MAINTENANCE BOND COVERING THE ROOFING SYSTEM WILL BE A REQUIREMENT OF THE SUCCESSFUL VENDOR.</p> <p>REV. 11/00</p> <p>EXHIBIT 7</p> <p>DOMESTIC ALUMINUM GLASS & STEEL IN PUBLIC WORKS PROJECTS</p> <p>IN ACCORDANCE WITH WEST VIRGINIA CODE 5-19-1 ET., SEQ., EVERY CONTRACT FOR CONSTRUCTION, RECONSTRUCTION, ALTERATION, REPAIR, IMPROVEMENT OR MAINTENANCE OF</p>						

SEE REVERSE SIDE FOR TERMS AND CONDITIONS

SIGNATURE	TELEPHONE	DATE
-----------	-----------	------

TITLE	FEIN	ADDRESS CHANGES TO BE NOTED ABOVE
-------	------	-----------------------------------

WHEN RESPONDING TO RFQ, INSERT NAME AND ADDRESS IN SPACE ABOVE LABELED 'VENDOR'



State of West Virginia
 Department of Administration
 Purchasing Division
 2019 Washington Street East
 Post Office Box 50130
 Charleston, WV 25305-0130

Request for Quotation

RFQ NUMBER
 DCH09029

PAGE
 4

ADDRESS CORRESPONDENCE TO ATTENTION OF:
 SHELLY MURRAY
 304-558-8801

RFQ COPY
 TYPE NAME/ADDRESS HERE

SUPPLIER

SHIP TO

DIVISION OF CULTURE & HISTORY
 GRAVE CREEK ARCHEOLOGY COMPLEX
 801 JEFFERSON AVENUE
 PO BOX 527
 MOUNDSVILLE, WV
 26041 304-558-0220

DATE PRINTED 09/05/2008	TERMS OF SALE	SHIP VIA	F.O.B.	FREIGHT TERMS
----------------------------	---------------	----------	--------	---------------

BID OPENING DATE: 10/09/2008 BID OPENING TIME 01:30PM

LINE	QUANTITY	UOP	CAT. NO.	ITEM NUMBER	UNIT PRICE	AMOUNT
<p>PUBLIC WORKS, WHERE THE COST IS MORE THAN \$50,000 AND, IN THE CASE OF STEEL ONLY, WHERE THE COST OF STEEL IS MORE THAN \$50,000 OR WHERE MORE THAN 10,000 POUNDS OF STEEL ARE REQUIRED, THE STATE WILL ACCEPT ONLY ALUMINUM GLASS, OR STEEL PRODUCTS PRODUCED IN THE UNITED STATES. IN ADDITION, ITEMS OF MACHINERY OR EQUIPMENT PURCHASED FOR USE AT THE SITE OF PUBLIC WORKS SHALL BE MADE OF DOMESTIC ALUMINUM, GLASS OR STEEL, UNLESS THE COST OF THE PRODUCT IS LESS THAN \$50,000 OR LESS THAN 10,000 POUNDS OF STEEL ARE USED IN PUBLIC WORKS PROJECTS.</p> <p>FOREIGN MADE ALUMINUM, GLASS OR STEEL PRODUCTS MAY BE ACCEPTED ONLY IF THE COST OF DOMESTIC PRODUCTS IS FOUND TO BE UNREASONABLE. SUCH COST IS UNREASONABLE IF IT IS 20% OR MORE HIGHER THAN THE BID PRICE FOR FOREIGN MADE PRODUCTS. IF THE DOMESTIC ALUMINUM, GLASS OR STEEL PRODUCTS TO BE SUPPLIED OR PRODUCED IN A "SUBSTANTIAL LABOR SURPLUS AREA", AS DEFINED BY THE UNITED STATES DEPARTMENT OF LABOR, FOREIGN PRODUCTS MAY BE SUPPLIED ONLY IF DOMESTIC PRODUCTS ARE 30% OR MORE HIGHER IN PRICE THAN THE FOREIGN MADE PRODUCTS.</p> <p>IF, PRIOR TO THE AWARD OF A CONTRACT UNDER THE ABOVE PROVISIONS, THE SPENDING OFFICER OF THE SPENDING UNIT DETERMINES THAT THERE EXISTS A BID FOR LIKE FOREIGN ALUMINUM, GLASS OR STEEL THAT IS REASONABLE AND LOWER THAN THE LOWEST BID DOMESTIC PRODUCTS, THE SPENDING OFFICE MAY REQUEST, IN WRITING, A REEVALUATION AND REDUCTION IN THE LOWEST BID FOR SUCH DOMESTIC PRODUCTS. ALL VENDORS MUST INDICATE IN THEIR BID IF THEY ARE SUPPLYING FOREIGN ALUMINUM, GLASS OR STEEL.</p> <p>REV. 3/88</p> <p>EXHIBIT 9</p>						

SEE REVERSE SIDE FOR TERMS AND CONDITIONS

SIGNATURE	TELEPHONE	DATE
TITLE	FEIN	ADDRESS CHANGES TO BE NOTED ABOVE

WHEN RESPONDING TO RFQ, INSERT NAME AND ADDRESS IN SPACE ABOVE LABELED 'VENDOR'



State of West Virginia
 Department of Administration
 Purchasing Division
 2019 Washington Street East
 Post Office Box 50130
 Charleston, WV 25305-0130

Request for Quotation

RFQ NUMBER
 DCH09029

PAGE
 5

ADDRESS CORRESPONDENCE TO ATTENTION OF
 SHELLY MURRAY
 304-558-8801

RFQ COPY
 TYPE NAME/ADDRESS HERE

VENDOR

SHIP TO

DIVISION OF CULTURE & HISTORY
 GRAVE CREEK ARCHEOLOGY COMPLEX
 801 JEFFERSON AVENUE
 PO BOX 527
 MOUNDSVILLE, WV
 26041 304-558-0220

DATE PRINTED	TERMS OF SALE	SHIP VIA	FOB	FREIGHT TERMS
09/05/2008				

BID OPENING DATE: 10/09/2008 BID OPENING TIME 01:30PM

LINE	QUANTITY	UOP	CAT. NO.	ITEM NUMBER	UNIT PRICE	AMOUNT
<p>NOTICE FOR ISSUANCE & ACKNOWLEDGEMENT OF CONSTRUCTION PROJECT ADDENDA</p> <p>THE ARCHITECT/ENGINEER AND/OR AGENCY SHALL BE REQUIRED TO ABIDE BY THE FOLLOWING SCHEDULE IN ISSUING CONSTRUCTION PROJECT ADDENDA FOR STATE AGENCIES:</p> <p>(1) THE ARCHITECT/ENGINEER SHALL PREPARE THE ADDENDUM AND A LIST OF ALL PARTIES THAT HAVE PROCURED DRAWINGS AND SPECIFICATIONS FOR THE PROJECT. THE ADDENDUM AND LIST SHALL BE FORWARDED TO THE BUYER IN THE STATE PURCHASING DIVISION. THE ARCHITECT/ENGINEER SHALL ALSO SEND A COPY OF THE ADDENDUM TO THE STATE AGENCY FOR WHICH THE CONTRACT IS ISSUED.</p> <p>(2) THE BUYER SHALL SEND THE ADDENDUM TO ALL INTERESTED PARTIES AND, IF NECESSARY, EXTEND THE BID OPENING DATE. ANY ADDENDUM SHOULD BE RECEIVED BY THE BUYER WITHIN FOURTEEN (14) DAYS PRIOR TO THE BID OPENING DATE.</p> <p>(3) ALL ADDENDA SHOULD BE FORMALLY ACKNOWLEDGED BY ALL BIDDERS AND SUBMITTED TO THE STATE PURCHASING DIVISION. THE SAME RULES AND REGULATIONS THAT APPLY TO THE ORIGINAL BIDDING DOCUMENT SHALL ALSO APPLY TO AN ADDENDUM DOCUMENT. THE ONLY EXCEPTION MAY BE FOR AN ADDENDUM THAT IS ISSUED FOR THE SOLE PURPOSE OF CHANGING A BID OPENING TIME AND/OR DATE.</p> <p>REV. 11/96</p> <p>EXHIBIT 10</p>						

SEE REVERSE SIDE FOR TERMS AND CONDITIONS

SIGNATURE	TELEPHONE	DATE
-----------	-----------	------

TITLE	FEIN	ADDRESS CHANGES TO BE NOTED ABOVE
-------	------	-----------------------------------

WHEN RESPONDING TO RFQ, INSERT NAME AND ADDRESS IN SPACE ABOVE LABELED 'VENDOR'



State of West Virginia
 Department of Administration
 Purchasing Division
 2019 Washington Street East
 Post Office Box 50130
 Charleston, WV 25305-0130

**Request for
 Quotation**

RFQ NUMBER
DCH09029

PAGE
6

ADDRESS CORRESPONDENCE TO ATTENTION OF
SHELLY MURRAY
304-558-8801

RFQ COPY
 TYPE NAME/ADDRESS HERE

VENDOR

SHIP TO

DIVISION OF CULTURE & HISTORY
 GRAVE CREEK ARCHEOLOGY COMPLEX
 801 JEFFERSON AVENUE
 PO BOX 527
 MOUNDSVILLE, WV
 26041 304-558-0220

DATE PRINTED	TERMS OF SALE	SHIP VIA	F.O.B.	FREIGHT TERMS
09/05/2008				

BID OPENING DATE: 10/09/2008 BID OPENING TIME 01:30PM

LINE	QUANTITY	UGP	CAT NO.	ITEM NUMBER	UNIT PRICE	AMOUNT
ADDENDUM ACKNOWLEDGEMENT						
I HEREBY ACKNOWLEDGE RECEIPT OF THE FOLLOWING CHECKED ADDENDUM(S) AND HAVE MADE THE NECESSARY REVISIONS TO MY PROPOSAL, PLANS AND/OR SPECIFICATION, ETC.						
ADDENDUM NOS.:						
NO. 1		C.M.F.	9/25/08			
NO. 2		C.M.F.	9/29/08			
NO. 3						
NO. 4						
NO. 5						
I UNDERSTAND THAT FAILURE TO CONFIRM THE RECEIPT OF THE ADDENDUM(S) MAY BE CAUSE FOR REJECTION OF THE BIDS.						
VENDOR MUST CLEARLY UNDERSTAND THAT ANY VERBAL REPRESENTATION MADE OR ASSUMED TO BE MADE DURING ANY ORAL DISCUSSION HELD BETWEEN VENDOR'S REPRESENTATIVES AND ANY STATE PERSONNEL IS NOT BINDING. ONLY THE INFORMATION ISSUED IN WRITING AND ADDED TO THE SPECIFICATIONS BY AN OFFICIAL ADDENDUM IS BINDING.						
<i>Charles McGadden</i>				SIGNATURE		
<i>EXP. Electric Co.</i>				COMPANY		
<i>10/24/08</i>				DATE		
REV. 11/96						

SEE REVERSE SIDE FOR TERMS AND CONDITIONS						
SIGNATURE	TELEPHONE			DATE		
TITLE	FEIN	ADDRESS CHANGES TO BE NOTED ABOVE				

WHEN RESPONDING TO RFQ, INSERT NAME AND ADDRESS IN SPACE ABOVE LABELED 'VENDOR'



State of West Virginia
 Department of Administration
 Purchasing Division
 2019 Washington Street East
 Post Office Box 50130
 Charleston, WV 25305-0130

Request for Quotation

RFQ NUMBER
 DCH09029

PAGE
 7

ADDRESS CORRESPONDENCE TO ATTENTION OF:
 SHELLY MURRAY
 304-558-8801

RFQ COPY
 TYPE NAME/ADDRESS HERE

VENDOR

SHIP TO

DIVISION OF CULTURE & HISTORY
 GRAVE CREEK ARCHEOLOGY COMPLEX
 801 JEFFERSON AVENUE
 PO BOX 527
 MOUNDSVILLE, WV
 26041 304-558-0220

DATE PRINTED	TERMS OF SALE	SHIP VIA	FOB	FREIGHT TERMS
09/05/2008				

BID OPENING DATE: 10/09/2008 BID OPENING TIME 01:30PM

LINE	QUANTITY	UOP	CAT NO	ITEM NUMBER	UNIT PRICE	AMOUNT
<p>CONTRACTORS LICENSE</p> <p>WEST VIRGINIA STATE CODE 21-11-2 REQUIRES THAT ALL PERSONS DESIRING TO PERFORM CONTRACTING WORK IN THIS STATE MUST BE LICENSED. THE WEST VIRGINIA CONTRACTORS LICENSING BOARD IS EMPOWERED TO ISSUE THE CONTRACTORS LICENSE. APPLICATIONS FOR A CONTRACTORS LICENSE MAY BE MADE BY CONTACTING THE WEST VIRGINIA DIVISION OF LABOR CAPITOL COMPLEX, BUILDING 3, ROOM 319, CHARLESTON, WV 25305. TELEPHONE: (304) 558-7890.</p> <p>WEST VIRGINIA STATE CODE 21-11-11 REQUIRES ANY PROSPECTIVE BIDDER TO INCLUDE THE CONTRACTORS LICENSE NUMBER ON THEIR BID.</p> <p>BIDDER TO COMPLETE:</p> <p>CONTRACTORS NAME: <i>ERB ELECTRIC Co</i></p> <p>CONTRACTORS LICENSE NO.: <i>WV.003498</i></p> <p>THE SUCCESSFUL BIDDER WILL BE REQUIRED TO FURNISH A COPY OF THEIR CONTRACTORS LICENSE PRIOR TO ISSUANCE OF A PURCHASE ORDER/CONTRACT</p> <p>APPLICABLE LAW</p> <p>THE WEST VIRGINIA STATE CODE, PURCHASING DIVISION RULE AND REGULATIONS, AND THE INFORMATION PROVIDED IN THE "REQUEST FOR QUOTATION" ISSUED BY THE PURCHASING DIVISION IS THE SOLE AUTHORITY GOVERNING THIS PROCUREMENT.</p> <p>ANY INFORMATION PROVIDED IN SPECIFICATION MANUALS, OR</p>						

SEE REVERSE SIDE FOR TERMS AND CONDITIONS

SIGNATURE	TELEPHONE	DATE
-----------	-----------	------

TITLE	FEIN	ADDRESS CHANGES TO BE NOTED ABOVE
-------	------	-----------------------------------

WHEN RESPONDING TO RFQ, INSERT NAME AND ADDRESS IN SPACE ABOVE LABELED 'VENDOR'



State of West Virginia
 Department of Administration
 Purchasing Division
 2019 Washington Street East
 Post Office Box 50130
 Charleston, WV 25305-0130

Request for Quotation

RFQ NUMBER
 DCH09029

PAGE
 8

ADDRESS CORRESPONDENCE TO ATTENTION OF
 SHELLY MURRAY
 304-558-8801

RFQ COPY
 TYPE NAME/ADDRESS HERE

VENDOR

SHIP TO

DIVISION OF CULTURE & HISTORY
 GRAVE CREEK ARCHEOLOGY COMPLEX
 801 JEFFERSON AVENUE
 PO BOX 527
 MOUNDSVILLE, WV
 26041 304-558-0220

DATE PRINTED	TERMS OF SALE	SHIP VIA	F.O.B.	FREIGHT TERMS
09/05/2008				

BID OPENING DATE: 10/09/2008 BID OPENING TIME 01:30PM

LINE	QUANTITY	UOP	CAT NO.	ITEM NUMBER	UNIT PRICE	AMOUNT
<p>ANY OTHER SOURCE, VERBAL OR WRITTEN, WHICH CONTRADICTS OR ALTERS THE INFORMATION PROVIDED FROM THE SOURCES AS DESCRIBED IN THE ABOVE PARAGRAPH IS VOID AND OF NO EFFECT.</p> <p>BANKRUPTCY: IN THE EVENT THE VENDOR/CONTRACTOR FILES FOR BANKRUPTCY PROTECTION, THIS CONTRACT IS AUTOMATICALLY NULL AND VOID, AND IS TERMINATED WITHOUT FURTHER ORDER.</p> <p>REV. 1/2005</p> <p style="text-align: center;">NOTICE</p> <p>A SIGNED BID MUST BE SUBMITTED TO:</p> <p style="text-align: center;">DEPARTMENT OF ADMINISTRATION PURCHASING DIVISION BUILDING 15 2019 WASHINGTON STREET, EAST CHARLESTON, WV 25305-0130</p> <p>THE BID SHOULD CONTAIN THIS INFORMATION ON THE FACE OF THE ENVELOPE OR THE BID MAY NOT BE CONSIDERED:</p> <p>SEALED BID</p> <p>BUYER: SHELLY MURRAY / FILE 31</p> <p>REQ. NO.: DCH09029</p> <p>BID OPENING DATE: 10/09/2008</p> <p>BID OPENING TIME: 1:30 PM</p>						

SEE REVERSE SIDE FOR TERMS AND CONDITIONS

SIGNATURE	TELEPHONE	DATE
TITLE	FEIN	ADDRESS CHANGES TO BE NOTED ABOVE

WHEN RESPONDING TO RFQ, INSERT NAME AND ADDRESS IN SPACE ABOVE LABELED 'VENDOR'



State of West Virginia
 Department of Administration
 Purchasing Division
 2019 Washington Street East
 Post Office Box 50130
 Charleston, WV 25305-0130

Request for Quotation

RFQ NUMBER
DCH09029

PAGE
9

ADDRESS CORRESPONDENCE TO ATTENTION OF
SHELLY MURRAY
304-558-8801

RFQ COPY
 TYPE NAME/ADDRESS HERE

VENDOR

SHIP TO

DIVISION OF CULTURE & HISTORY
 GRAVE CREEK ARCHEOLOGY COMPLEX
 801 JEFFERSON AVENUE
 PO BOX 527
 MOUNDSVILLE, WV
 26041 304-558-0220

DATE PRINTED	TERMS OF SALE	SHIP VIA	F.O.B.	FREIGHT TERMS
09/05/2008				

BID OPENING DATE: 10/09/2008 BID OPENING TIME 01:30PM

LINE	QUANTITY	UOP	CAT NO	ITEM NUMBER	UNIT PRICE	AMOUNT
PLEASE PROVIDE A FAX NUMBER IN CASE IT IS NECESSARY TO CONTACT YOU REGARDING YOUR BID: <p style="text-align: center;">----- 740-633-5127 -----</p> PLEASE PRINT OR TYPE NAME OF PERSON TO CONTACT CONCERNING THIS QUOTE: <p style="text-align: center;">----- Charles McFadden -----</p>						
***** THIS IS THE END OF RFQ DCH09029 ***** TOTAL:						<i>\$41,674⁰⁰</i>

SEE REVERSE SIDE FOR TERMS AND CONDITIONS

SIGNATURE	TELEPHONE	DATE
-----------	-----------	------

TITLE	FEIN	ADDRESS CHANGES TO BE NOTED ABOVE
-------	------	-----------------------------------

WHEN RESPONDING TO RFQ, INSERT NAME AND ADDRESS IN SPACE ABOVE LABELED 'VENDOR'

Division of Culture & History
Grave Creek Archeology Complex
Moundsville, West Virginia
DCH09029

Replacement of Emergency Generator System and Peripherals

1. Scope of Work:

- a. The work entails the provision of transportation, labor, and materials for the removal of the existing failed Emergency Generator Set (EmGenSet), existing remote radiator, existing fuel day tank, and existing Automatic Transfer Switch (ATS); movement, on-site, of the removed equipment to a holding area for disposal by others; modification, if necessary, of the existing concrete pad to accept a new unit; installation of a new EmGenSet with fuel sub-base tank and ATS; installation of a new motor actuator (direct or linkage connected and if required) to an existing screened, operable louver to provide make up outside ventilation air; EmGenSet system tie in to existing emergency power circuit panels; tie in to exhaust ducting, tank fuel filler piping and tank venting piping; testing and commissioning of the installed system, and staff training. All work to meet manufacturer's specifications and existing Federal, State, and Local Codes, Regulations, and Ordinances.

2. Sequence of Operation:

- a. **Power Failure Mode:** Upon the interruption of Utility provided electrical power to the building, the ATS shall be programmed to wait a maximum of ten (10) seconds to allow for generator startup-and transfer. ATS transfer will start the Emergency Generator in a two (2) step sequence. 1.) On generator start up; a mechanical actuator (energized open/ de-energized closed), powered by the Emergency Generator, shall energize and open an existing exterior wall mounted manual balancing damper to provide external make up air for the EmGenSet System. 2.) Once the generator has established a stable run cycle, the ATS shall transfer to energize the emergency circuit panel. Upon restoration of Utility power, the ATS shall wait for a minimum of two (2) minutes prior to transferring service back to Utility power and initiate a four (4) to five (5) minute (adjustable) "off-load" delay for EmGenSet "cool-down" cycle prior to automatically shutting down the EmGenSet.

A provision shall be made in the system to allow for emergency manual override of the actuated louver to provide for instances where outside conditions (i.e. smoke, toxic fumes, chemical/biological hazards...) prohibit use of outside air during Utility power interruptions.

- b. **Stand By Mode:** Provision shall be made for a once a week automatic test run, under load, for a minimum duration of ten (10) minutes to test under load conditions and to exercise the EmGenSet. If not an integral component of a vendor submitted ATS, the Owner will accept, with prior review and approval, a timing device with an actuating relay or similar run initiating device.

3. **Equipment:** (refer to attached "cut sheets" and below for reference)

NOTE to Vendors: All equipment specifications below and related attachments are intended to provide an example of the parameters required. "Or equal" submittals will be considered and reviewed but must be able to fulfill the **Sequence of Operation** requirements and be compatible with other system components in all respects.

Vendors suggesting equipment for consideration will be expected to provide adequate documentation describing the equipment in the form of "specification/cut sheets" or similar documentation. General "sales" brochures are not an acceptable form of submittal.

1) **Generator Set**

- a) **Generator:** Detroit Diesel Corp. /MTU Power Generator, Model # 30PJS6DT2, 30kW, 37.5 kVA, 120/208 ACV 3-Phase, 30 ekW 60Hz (Standby), 25 ekW-60Hz (Prime). With Basler Digital Genset Controller # DGC-500, isochronous governor (+/- 25%), and UL2200 Listing.
 - i) **Engine:** John Deere model # 4024TF270; 4 cycle, 2.4 Liter, 1800 RPM @ 60HZ. Unit mounted radiator. Block Heater rated @ -20 degrees F 1500 Watts
 - ii) **Battery:** Lead/Acid 750 Cold Cranking Amps @ 0 degrees F. Genset Unit to include a 12V/6A mounted battery charger (AC & DC wiring included)
 - iii) **Sub-Base Fuel Tank w/ stub ups for piping:** 105 gal, double wall, UL 142 approved, meeting NFPA-30 standard, with fuel leak and low fuel level alarm sensors, 1.5" normal vent cap, 2" locking fuel cap, and 2-6" NPT opening for emergency vent.
 - iv) **125 Amp Circuit Breaker:** 480 V/ 3-Phase- Mounted and wired in NEMA-1 Enclosure.
 - v) Vibration Isolation Pads included and installed (**NOTE:** In addition to Manufacturer supplied isolation, Vendor/Installer is to make provision for Vibration Isolation involving vent and filler piping, conduit, exhaust and any related peripherals attached to EmGenSet.)
 - vi) **Manufacturer's Warranty:** 2 (two) year / 3000 hour warranty

2) **Automatic Transfer Switch (ATS):**

- a) ASCO Series D300 Automatic Transfer Switch (30 through 230 Amps) with ASCO 11BG engine exercise module.

3) **Mechanical Actuator, Spring return**

(NOTE: Example below is intended to represent an actuator capable of generating sufficient torque to open louver. Actuator may require mounting plate, crank-arm, and or linkage accessories. Check existing louver on site to select proper torque range. Selection of a 24 volt control voltage actuator requires installation of 120V/ 24 VAC step-down transformers.)

- i. **Brand:** **Belimo**
- ii. **Model:** **AF24-SR US**

(Note to Vendor: The facility has recently undergone renovations to the HVAC system. It is possible that a new actuator may already be in place. If so, the Vendor/Installer, following verification by new actuator manufacturer, is to land required wiring to provide control voltage to override HVAC control settings. In this case, The Vendor is to back out the cost of providing a mechanical actuator from the bid.)

4) **Additional information:**

- a) Diesel fuel is to be supplied by the Agency. The State of West Virginia has a State Wide Contract for Diesel fuel. The Vendor is to notify the Agency in advance when the fuel is needed for testing and commissioning. The Agency will then make arrangements for delivery and inform the Vendor.
- b) The Vendor is to supply and install filler and fuel vent piping to allow for exterior fill-up of the integrated tank (refer to print). Follow manufacturer's recommendations for installation. The filler cap is to be lockable either by padlock (supplied by Agency) or other means.
- c) The Exhaust system is being tested by the Agency for asbestos. If testing proves positive. The Agency will address removal and provide documentation to vendors if needed.

END OF SPECIFICATIONS

DETROIT DIESEL

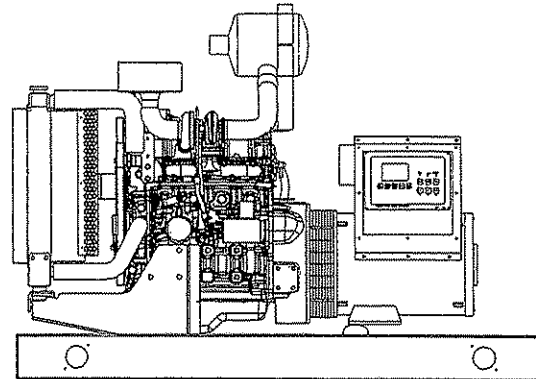
30 ekW 60 Hz Standby
208 - 600V

- EPA Tier 2 Certified
- Generator Set Tested to ISO 8528-5 for Transient Response
- UL2200, CSA Listing Offered
- Accepts Rated Load in One Step Per NFPA 110, Level 1
- All gen-sets are prototype and factory tested
- MTU DD is a single source supplier
- Global Product Support
- 2 Year Standard Warranty
- Complete Range of Accessories

4024TF270 Diesel Engine

- 2.4 Liter Displacement
- 4-Cycle

Permanent Magnet Generator (PMG) - Optional

- Brushless, Rotating Field
- 300% Short Circuit Capability
- 2/3 Pitch Windings

Digital Control Panel

- UL 508 Listed, CSA Certified, NFPA 110
- Complete System Metering
- LCD Display

Cooling System

- Integral Set-mounted
- Engine Driven Fan

GEN-SET RATINGS

Standby - 130^e Rise

Voltage (L-L)	Phase	PF	Hz	kW	kVA	AMPS	skVA @ 30% voltage dip	Model	Connections
240v	1	1.0	60	30	30	125	48	284PSL1508	12 LEAD ZIG-ZAG
208v	3	0.8	60	30	37.5	104	93	284PSL1508	12 LEAD LOW WYE
240v	3	0.8	60	30	37.5	90	93	284PSL1508	12 LEAD HI DELTA
→ 480v	3	0.8	60	30	37.5	45	123	284PSL1508	12 LEAD HI WYE
600v	3	0.8	60	30	37.5	36	123	284PSL1752	4 LEAD WYE



30 kW Diesel Gen-Set

STANDARD EQUIPMENT

ENGINE

- Air Cleaner
- Oil Pump
- Full Flow Oil Filter
- Jacket Water Pump
- Closed Crankcase Vent
- Thermostats
- Exhaust Manifold – dry
- Blower Fan & Fan Drive
- Radiator - Unit Mounted
- Electric Starting Motor - 12V
- Governor – Electric Isochronous
- Base - Formed Steel
- SAE Flywheel & Bell Housing
- Charging Alternator - 12V
- Battery Box & Cables
- Flexible Fuel Connectors
- Flexible Exhaust Connection
- EPA Certified Engine

DIGITAL CONTROL PANEL

- Digital Metering
- Engine Parameters
- Generator Protection Functions
- Engine Protection
- SAE J1939 Engine ECU Communications
- Windows-based Software
- Multilingual Capability
- Remote Communications to our RDP-110 Remote Annunciator
- 16 Programmable Contact Inputs
- 7 Contact Outputs
- UL Recognized, CSA Certified, CE Approved
- Event Recording
- IP 54 Front Panel Rating with Integrated Gasket
- NFPA110 Level Compatible

GENERATOR

- NEMA MG1, IEEE and ANSI standards compliance for temperature rise and motor starting
- Sustained short circuit current of up to 300% of the rated current for up to 10 seconds
- Self Ventilated and Drip-proof
- Superior Voltage Waveform
- Digital, Solid State, Volts-per-hertz Regulator
- No load to full load regulation
- Brushless Alternator with Brushless Pilot Exciter
- 4 pole, Rotating Field
- 130°C Standby Temperature Rise
- 1 Bearing, Sealed
- Flexible Coupling
- Full Amortisseur Windings
- 125% Rotor Balancing
- 3-phase Voltage Sensing
- ±1% Voltage Regulation
- 100% of Rated Load - One Step
- 3% Maximum Harmonic Content

ADDITIONAL FEATURES

- Oil Drain Extension & S/O Valve
- Flexible Fuel Connector
- Battery Cables
- Vibration Isolation Pads
- Jacket Water Heater: -20° F
- Mainline Circuit Breaker
- UL2200 Listed
- Steel Sub-base
- Radiator Duct Flange (OPU)
- Lube Oil & Antifreeze
- Operator's and Owner's Manual
- 2 year/3000 hour Warranty
- Factory Tested at .8 PF (3 PH)

OPTIONAL FEATURES

- Battery Charger 6 amp or 10 amp
- Battery: 12 volt w/ rack
- Circuit Breaker: Standard or 100%
- Muffler (OPU only)
- Sub-base Fuel Tank w/ Electrical stub-up area
- Weatherproof Enclosure
- Sound Attenuation
 - 1 1/2" Foam
 - Sound Scoops
- Remote Annunciator
- Isochronous Governor



30 ekW Diesel Gen-Set

APPLICATION DATA

Engine

Manufacturer:	John Deere	Rated RPM:.....	1800
Model:	4024TF270	Engine Governor:.....	Electric Isochronous
Type:.....	4-Cycle	Max Power: Standby: bhp (kWm) ..	48 (36)
Arrangement:	4-Inline	Speed Regulation:	±1%
Displacement: in. ³ (lit)	149 (2.4)	Frequency:	60 Hz
Bore: in. (cm)	3.4 (8.6)	Air Cleaner:.....	Dry
Stoke: in. (cm)	4.1 (10.5)		
Compression Ratio:.....	20.5:1		

Liquid Capacity (Lubrication)

Total oil system (gal/lit):.....	2.1 (8.0)
Engine jacket water capacity (gal/lit):	0.675 (2.6)
System Coolant capacity (gal/lit):	2.29 (8.7)

Electrical

Electric volts DC	12
Cold cranking Amps under 0°F (-17.8°C)	750

Fuel System

Fuel Supply Connection Size:.....	³ / ₈ "NPT
Fuel Return Connection Size:	³ / ₈ "NPT
Maximum Fuel Lift: ft (m)	10(3)
Recommended Fuel:	Diesel #2
Total Fuel Flow: gal/hr (lit/hr)	26.4 (100)

Fuel Consumption

	Standby
At 100% of Power Rating:gal/hr (lit/hr)	2.8 (10.6)
At 75% of Power Rating:gal/hr(lit/hr)	2.1 (8.0)
At 50% of Power Rating:gal/hr (lit/hr)	1.4 (5.3)

Cooling - Radiator System

	Standby
Ambient Capacity of Radiator °F (°C):	122 (50)
Maximum Allowable Static Pressure on Rad. Exhaust H ₂ O (kPa):	0.5(12)
Water Pump Capacity gpm (lit/min):	24 (91)
Heat Rejection to Coolant BTUM (kW):	1,412 (25)
Heat Radiated to Ambient BTUM (kW):	293 (5.2)

Air Requirements

	Standby
Aspirating CFM (m ³ min):.....	106 (3.0)
Air Flow Required for Rad. Cooled Unit CFM (m ³ min):	3,875 (109.7)
Air Flow Required for Heat Exchanger/Remote Rad. based on 25°F Rise CFM (m ³ min):	650 (18.4)

Exhaust System

	Standby	Prime
Gas Temp.(Stack)°F (°C):.....	1,026 (552)	963 (517)
Gas Volume at Stack Temp CFM (m ³ min):	283 (8.0)	261 (7.4)
Maximum Allowable Back Pressure H ₂ O (kPa):	30 (7.5)	30 (7.5)



30 kW Diesel Gen-Set

EMISSIONS DATA

<u>NOx + NMHC</u>	<u>CO</u>	<u>PM</u>
4.93	1.89	0.12

All units are in g/hp-hr and are EPA D2 cycle values.

Emission levels of the engine may vary as a function of ambient temperature, barometric pressure, humidity, fuel type and quality, installation parameters, measuring instrumentation, etc. The data provided are laboratory results from one engine representing this rating. The data was obtained under controlled environmental conditions with calibrated instrumentation traceable to the United States National Bureau of Standards and in compliance with US EPA regulations found within 40 CFR Part 89. The weighted cycle value from each engine is guaranteed to be below the US EPA Standards at the US EPA defined conditions.

SOUND DATA

	<u>Standby Full Load</u>	<u>Standby No Load</u>
23 ft (7m) OPU w/ critical grade muffler (dBA)	84	74
23 ft (7m) Sound Attenuated Enclosure (dBA)	76	66

RATING DEFINITIONS and CONDITIONS

- Ambient capability factor at 300M (984ft). Consult your local MTU DD Power Generation Distributor for other altitudes.
- Standby ratings apply to installations served by a reliable utility source. The standby rating is applicable to varying loads for the duration of a power outage. No overload capability for this rating. Ratings are in accordance with ISO-3046/1, BS 5514, AS 2789, and DIN 6271.
- Prime power ratings apply to installations where utility power is unavailable or unreliable. At varying load, the number of generator set operating hours is unlimited. A 10% overload capacity is available for one hour in twelve. Ratings are in accordance with ISO-8528/1, overload power in accordance with ISO-3046/1, BS 5514, AS 2789, and DIN 6271. For limited running time and base load ratings, consult the factory.
- Deration Factors:
 Altitude: Derate 4% per 1,000 ft (305m) above 10,000 ft (3,050m).
 Temperature: Derate 0.5% per 10°F (5.5°C) above 77°F (25°C).

Weights & Dimensions

	<u>OPU</u>	<u>EPU</u>
Length: in. (cm)	70 (178)	70 (178)
Width: in. (cm)	34 (86)	34 (86)
Height: in. (cm)	52 (132)	59 (150)
Height w/ Tank: in. (cm)	76 (193)	83 (211)
Weight (less tank): lb (kg)	1,695 (796)	2,345 (1,064)

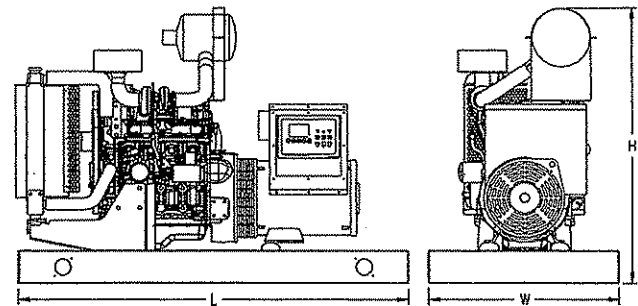

Drawing above for illustration purposes only, based on standard open power 480 volt generator. Lengths may vary with other voltages.
*Do Not Use for Installation Design

DISTRIBUTED BY:

Materials and specifications subject to change without notice.
© MTU DD Power Generation. A Tognum Group Company.
100 Power Drive, Mankato, MN 56001
Phone: 800-325-5450
www.mtuddpowergeneration.com

ASCO SERIES 300 AUTOMATIC TRANSFER SWITCH

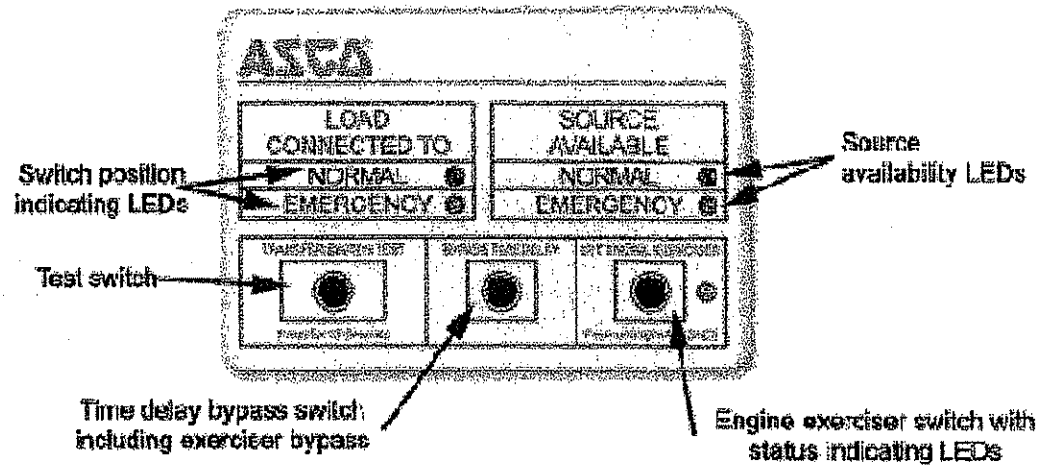
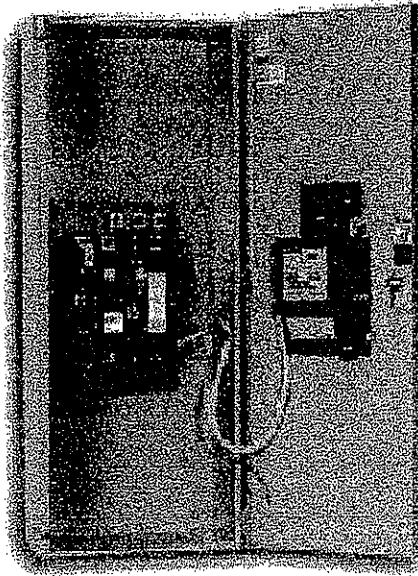

GENERATOR TRANSFER SWITCH CONTROL PANEL

STANDARD FEATURES

- Motor load transfer controls (inphase monitor) to keep motors operating during transfer.
- Pre-transfer & post-transfer load disconnect contacts for signaling motor starters, elevators, VFDs and other selected loads.
- Standard Engine Exerciser for weekly automatic testing of engine generator set with or without load.
- Selectable control switches for voltage, frequency, time delay settings & additional control features.
- Switch position lights, source availability lights, test switch and time delay bypass switch.

TIME DELAYS

- Adjustable time delay to over ride momentary normal source outages to delay all transfer switch and engine-starting signals.
- Transfer to emergency time delay. Adjustable from 0 to 5 minutes for controlled timing of load transfer to emergency.
- Retransfer to normal time delay. Adjustable to 30 minutes.
- Five-minute unloaded running time delay for emergency engine generator cool down.
- Four-second time delay to override momentary to ignore momentary voltage and frequency transients during initial genset loading.

VOLTAGE & FREQUENCY SENSING

- Adjustable three-phase, close differential voltage sensing on normal source.
- Normal source pickup voltage is adjustable to 95% of nominal; drop-out is adjustable from 70 to 90% of nominal.
- Frequency sensing on emergency source. Pickup at 95% and dropout at 85% of nominal.

STANDARD CONTROL CONTACTS

- Switch position indicating contacts (rated 10 amps 250VAC, 32VDC). (1) for Normal position, (1) for Emergency position.
- Gold plated engine start contacts (rated 5 amps 28VDC or 120VAC).

REMOTE CONTROL FEATURES

- Remote test switch.
- Remote contact for test or for peak shaving applications. Circuit will be automatically bypassed if emergency source fails.
- Inhibit transfer to emergency.
- Remote time delay bypass switch.

Accessory 11BG Installation

for ASCO® Series 300 Automatic Transfer Switches

The Accessory 11BG module includes a programmable engine exerciser and source availability contacts. It can be added to Series 300 Automatic Transfer Switches that have Group 1 Controllers. If an existing exerciser (Acc. 11CD) is already installed, the old exerciser must be disconnected.

The Accessory 11BG module mounts directly behind the operator interface. The module connects to the operator interface and to the Group 1 controller.

Kit K629830 includes the Acc. 11BG module, mounting hardware, and all necessary wiring.

Tools required: 1/4" and 5/16" nut drivers
small blade screwdriver

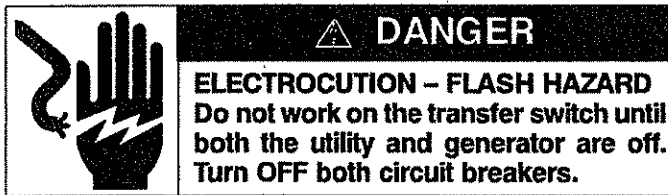

Module Installation

1. With all power OFF, open the enclosure door. Locate the operator interface (membrane controls) mounted on the inside of the enclosure door. Use a 5/16" nutdriver to remove (counterclockwise) the four hex nuts from the corners of the operator interface. Do not remove the operator interface board.
2. Install (clockwise) four standoffs (from the kit) onto the four studs and tighten them with a 1/4" nutdriver.
3. Install the Acc. 11BG module on top of the operator interface so that four standoffs fit through the corner holes. Then install (clockwise) four 6-32 hex nuts (from the kit) to secure the assembly. Tighten the nuts.

Connecting the Module

1. With all power OFF, locate the two ribbon cables and note direction and orientation of each cable.
2. First, unplug the ribbon cable (coming from the Controller) from the operator interface (J3 lower right side) and reconnect it (same orientation) to the Acc. 11BG module (J1 lower right side).
3. Second, connect the new ribbon cable (coming from the Acc. 11BG module upper right side) to the operator interface (J3 lower right side) with the same orientation as the original cable that was moved.
4. Third, strip the insulation from both ends of the #16 gauge white wire (from the kit). Connect this prepared wire between Acc. 11BG module terminal 9 (right side) and the Group 1 Controller terminal 4 (bottom left).

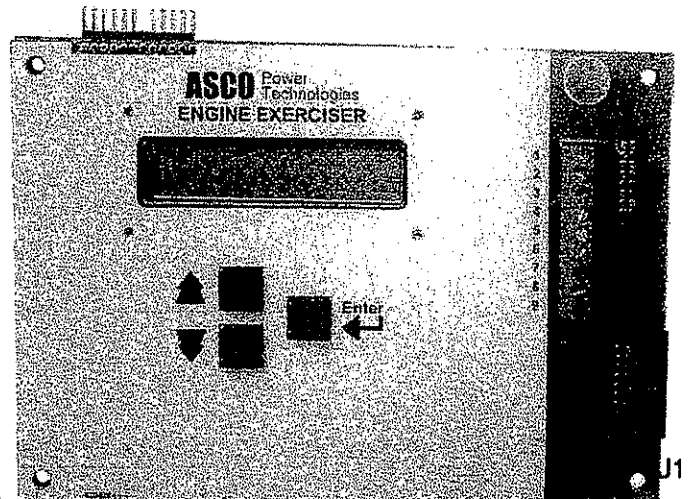

Figure 1. Accessory 11BG Module

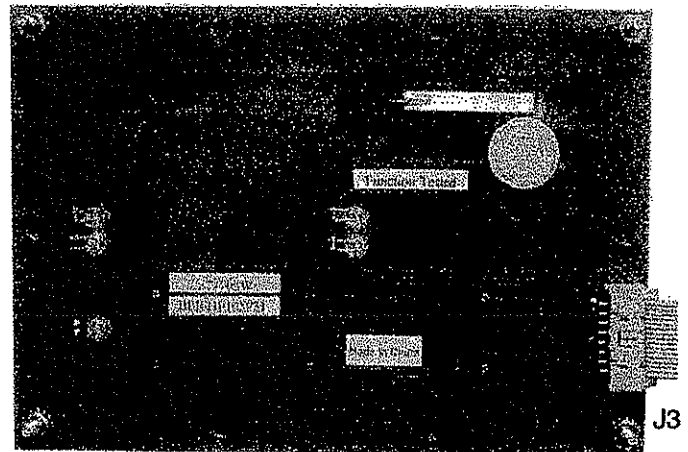

Figure 2. Operator Interface board (back view)

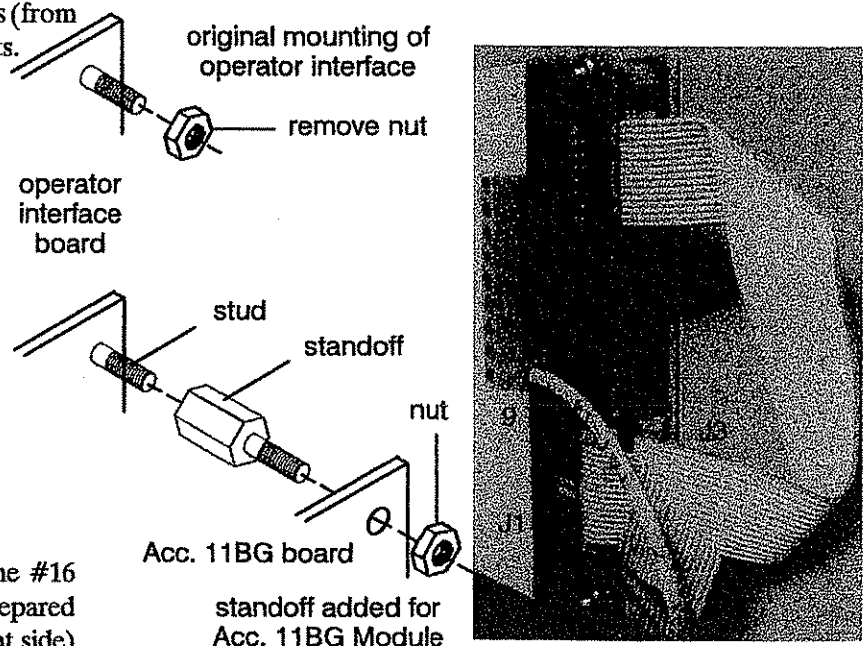

Figure 3. Acc. 11BG mounting hardware and wiring.

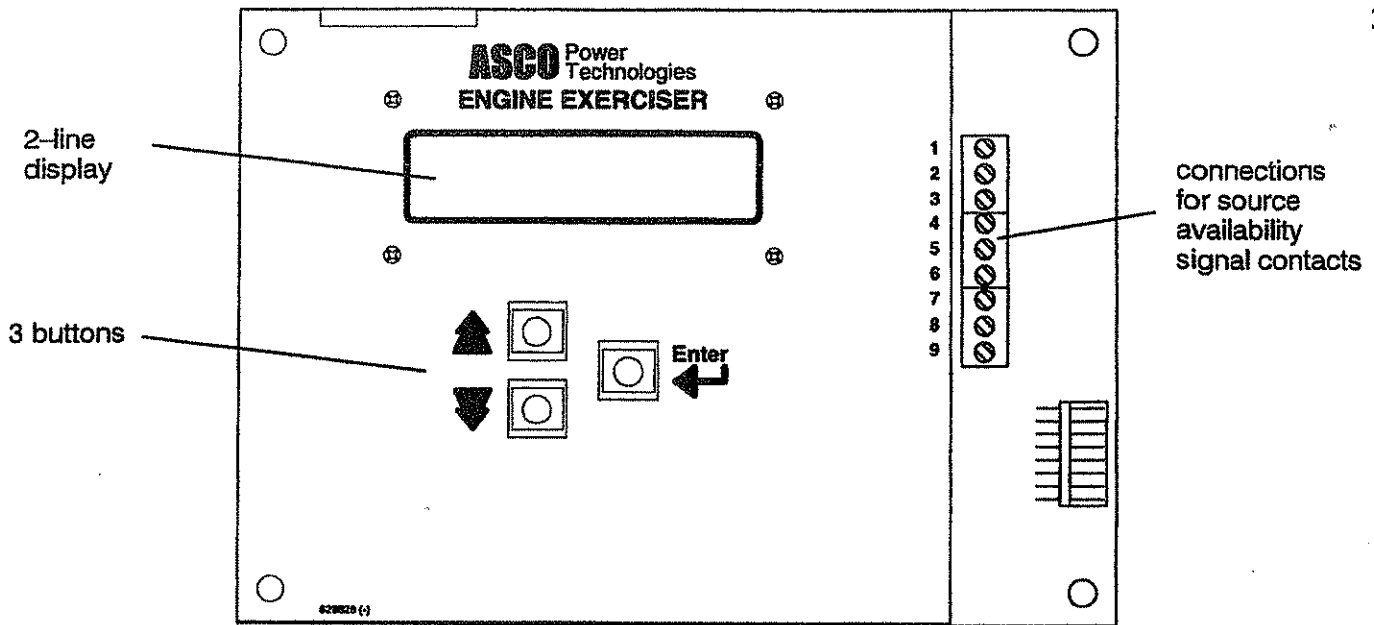

Figure 4. Accessory 11BG module (mounted behind operator interface and connected to the controller) includes source availability signal contacts and a programmable engine exerciser.

Source Availability Signal Contacts

The module provides one Form C contact each for the normal and emergency sources to signal the acceptability of the source as sensed by the controller. The signal contacts operate in conjunction with the *Source Available* lights on the operator interface. Field wiring terminals are provided as shown in Figure 5 and the wiring diagram.

Contact ratings:

2 amps @ 30 Vdc, 0.5 amp. @ 125 Vac resistive

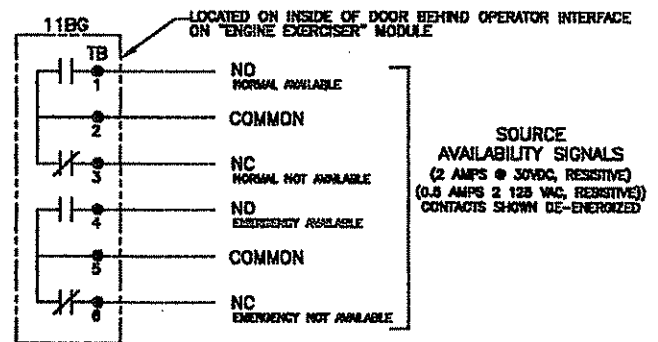

Figure 5. Source availability signal contacts.

Programmable Engine Exerciser

The module includes a programmable engine exerciser that provides for weekly or biweekly operation. This optional exercise timer may have to be turned on (enabled) by setting the S1 DIP switch actuator 7 to off, and S2 DIP switch actuator 5 to off. A backup battery in the controller (see the Operator's Manual, Sections 4 and 5) must be turned on to maintain the settings and to allow programming with the normal and emergency power turned off.

The programmable engine exerciser incorporates a 7 day or 14 day time base. Proper controller settings must be made to determine whether or not the test will be done with or without load transfer (S1 DIP switch actuator 8).

See next page for instructions on setting the timer.

DIP Switch Settings

FUNCTION	S1 DIP SWITCH	S2 DIP SWITCH
Opt. Timer Enabled	Actuator 7 off	Actuator 5 off
Opt. Timer Disabled	Actuator 7 off	Actuator 5 on
Exercise without Load	Actuator 8 off	
Exercise with Load	Actuator 8 on	

Shaded DIP switches are standard factory settings.

⚠ DANGER

Hazardous voltage capable of causing shock, burns, or death is used in this transfer switch. Deenergize both Normal & Emergency power sources before programming the exerciser.

Navigating the Menu

Use the UP and DOWN arrow keys to move through the displays.

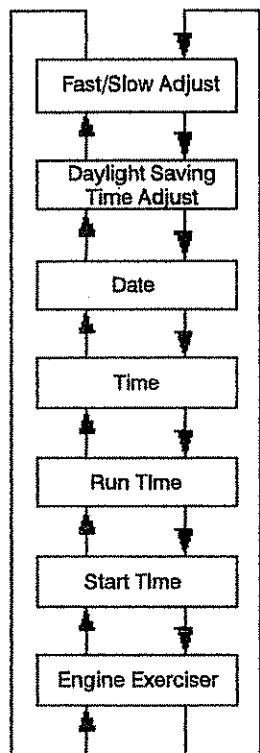

Changing the Parameters

Use the UP and DOWN arrow keys to move through the displays to the parameter to be changed. Push the ENTER key to start the editing process. The first parameter will flash. Use the UP and DOWN arrow keys to adjust the parameter to the desired value and press the ENTER key to save the value. The next parameter will now flash. Repeat the process until each parameter is properly configured.

Engine Exerciser Display

The Engine Exerciser Display shows the status of the engine exerciser. When the unit is shipped from the factory the programmable engine exerciser is “Disabled” and must be set to “Enabled” by the customer. When the engine exerciser is running, this display will count down the remaining time until the end of the exercise period.

Start Time Display

The Start Time Display shows the engine exerciser start time. There are four parameters that determine the start time:

- weekly (“Every”) or bi-weekly (“Alt”) operation
- day of week (“Sun” through “Sat”)
- start hour (0 through 23)
- start minutes (0 through 59)

For example, if the user wants the exerciser to run every other Saturday at 3 PM, the proper configuration would be:

“Alt Sat @ 15:00”

NOTE: When choosing bi-weekly operation, the exerciser will always run on the week designated “(1)” on the date display.

Run Time Display

The Run Time Display shows the run time for the engine exerciser. The default setting from the factory is 30 minutes.

Time Display

The Time Display shows the present system time. The format is “hours:minutes:seconds”.

NOTE: During total power outages, power to the accessory is maintained by a battery in the Controller (see page 4-2 of Operator’s Manual). Be sure that the 9-volt alkaline battery is fresh and enabled (jumper in ON position) so that the time and date settings are not lost.

Date Display

The Date Display shows the present system date. The format is “day of week (week) month/day of month/year”.

NOTE: Week is either week 1 or week 2. This is used in conjunction with the bi-weekly timer.

Daylight Savings Time Adjust Display

This display shows whether the automatic daylight saving time adjustment is active. The factory default is “NO”. If enabled, the unit will automatically adjust for daylight saving time at 2 AM on the first Sunday of April and the last Sunday of October.

Fast / Slow Adjust Display

This display shows the automatic fast/slow adjustment value. The factory default is 0. This feature can be used to trim a clock that runs fast or slow. For example, if your clock runs 10 seconds slow per week, change the fast/slow adjust value to “+10” and the unit will automatically add 10 seconds to the clock every week.

NOTE: Adjustments are made Sunday morning at 2 AM. If you want your exerciser period to start at 2 AM on Sunday, you cannot use this feature and the adjustment must be set to 0.

Programmable Engine Exerciser Settings

Fill in your settings for future reference

Weekly or Bi-weekly	Day of Week	Start Time	Run Time
<i>Every = weekly</i> <i>Alt = bi-weekly</i>	<i>Sun through Sat</i>	<i>0 – 23 hour</i> <i>0 – 59 minute</i>	<i>0 – 23 hour</i> <i>0 – 59 minute</i> <i>30 minutes is the default setting</i>

Date exerciser was set _____

Proportional Damper Actuator, Spring Return Fail-Safe, 24 V for 2 to 10 VDC and 4 to 20 mA Control Signal.
Output Signal of 2 to 10 VDC for Position Indication

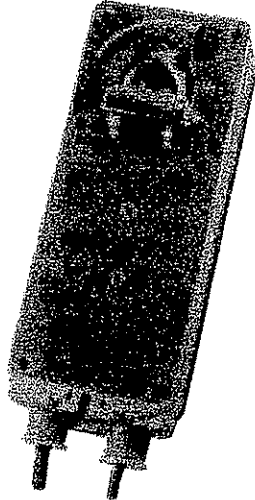

Torque min. 133 in-lb, for control of air dampers

Application

For proportional modulation of dampers in HVAC systems. Actuator sizing should be done in accordance with the damper manufacturer's specifications.

The actuator is mounted directly to a damper shaft up to 1.05" in diameter by means of its universal clamp. A crankarm and several mounting brackets are available for applications where the actuator cannot be direct coupled to the damper shaft.

The actuator operates in response to a 2 to 10 VDC, with the addition of a 500Ω resistor, a 4 to 20 mA control input from an electronic controller or positioner. A 2 to 10 VDC feedback signal is provided for position indication or master-slave applications.

Operation

The AF series actuators provide true spring return operation for reliable fail-safe application and positive close-off on air tight dampers. The spring return system provides constant torque to the damper with, and without, power applied to the actuator.

The AF series provides 95° of rotation and is provided with a graduated position indicator showing 0 to 95°. The AF has a unique manual positioning mechanism which allows the setting of any damper position within its 95° of rotation. The actuator is shipped at +5° position (5° from full fail-safe) to provide automatic compression against damper gaskets for tight shut-off. When power is applied, the manual mechanism is released and the actuator drives toward the full fail-safe position. The actuator will memorize the angle where it stops rotating and use this point for its zero position for its normal control operations. The manual override can also be released physically by the use of a crank supplied with the actuator.

The AF uses a brushless DC motor which is controlled by an Application Specific Integrated Circuit (ASIC) and a microprocessor. The microprocessor provides the intelligence to the ASIC to provide a constant rotation rate and to know the actuator's exact zero position. The ASIC monitors and controls the brushless DC motor's rotation and provides a digital rotation sensing function to prevent damage to the actuator in a stall condition. The actuator may be stalled anywhere in its normal rotation without the need of mechanical end switches.

Technical Data	AF24-SR US
Power supply	24 VAC ± 20% 50/60 Hz 24 VDC ± 10%
Power consumption	running: 6 W ; holding: 2 W
Transformer sizing	10 VA (class 2 power source)
Electrical connection	3 ft, 18 GA appliance cable 1/2" conduit connector
Overload protection	electronic throughout 0 to 95° rotation
Operating range Y	2 to 10 VDC, 4 to 20 mA
Input impedance	100 kΩ (0.1 mA), 500Ω
Feedback output U	2 to 10 VDC (max. 0.5 mA) for 95°
Angle of rotation	mechanically limited to 95°
Torque	133 in-lb [15 Nm] constant
Direction of rotation	spring: reversible with cw/ccw mounting motor: reversible with built-in switch
Position indication	visual indicator, 0° to 95° (0° is spring return position)
Manual override	3mm hex crank (shipped w/actuator)
Running time	150 sec. constant, independent of load, spring return < 20 sec
Humidity	5 to 95% RH non-condensing
Ambient temperature	-22°F to +122°F [-30°C to +50°C]
Storage temperature	-40°F to +176°F [-40°C to +80°C]
Housing	NEMA type 2 / IP54
Housing material	zinc coated metal
Agency listings	UL 873 listed, CSA C22.2 No. 24 certified
noise level	max. 45 dB (A)
Servicing	maintenance free
Quality standard	ISO 9001
Weight	6.0 lbs (2.7 kg)

Dimensions [All numbers in brackets are in millimeters.]

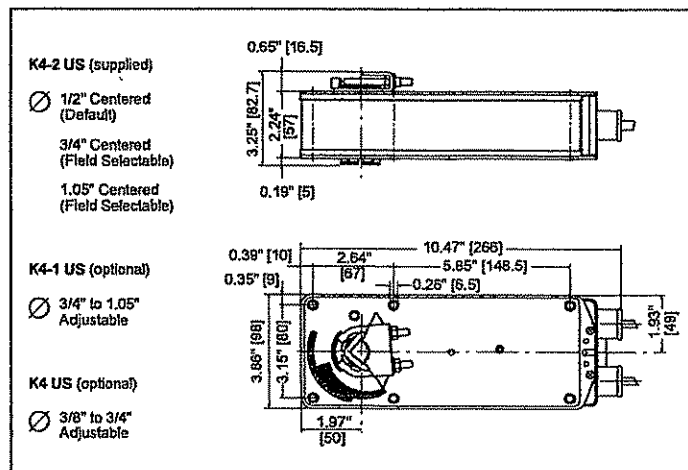

Proportional Damper Actuator, Spring Return Fail-Safe, 24 V for 2 to 10 VDC and 4 to 20 mA Control Signal.
Output Signal of 2 to 10 VDC for Position Indication

Accessories

AV 10-18	Shaft extension
IND-AF2	Damper position indicator
K4 US	Universal clamp for 3/8" to 3/4" shafts
K4-1 US	Universal clamp for up to 1.05" dia jackshafts
K4-H	Universal clamp for hexshafts 3/8" to 5/8"
KH-AF	Crankarm for up to 3/4" round shaft (Series 2)
KH-AF-1	Crankarm for up to 1.05" jackshaft (Series 2)
KH-AFV	V-bolt kit for KH-AF and KH-AF-1
Tool-06	8mm and 10 mm wrench
SGA24	Min. and/or man. positioner in NEMA 4 housing
SGF24	Min. and/or man. positioner for flush panel mounting
ZG-R01	500Ω resistor for 4 to 20 mA control signal
ZG-HTR	Thermostat/Heater Kit
ZDB-AF2	Angle of rotation limiter
ZG-100	Universal mounting bracket
ZG-101	Universal mounting bracket
ZG-102	Multiple actuator mounting bracket
ZG-103	Universal mounting bracket
ZG-104	Universal mounting bracket
ZG-106	Mounting bracket for Honeywell® Mod IV replacement or new crankarm type installations
ZG-107	Mounting bracket for Honeywell® Mod III or Johnson® Series 100 replacement or new crankarm type installations
ZG-108	Mounting bracket for Barber Colman® MA 3../4.., Honeywell® Mod III or IV or Johnson® Series 100 replacement or new crankarm type installations
ZG-AF US	Crankarm adaptor kit for AF/NF
ZG-AF108	Crankarm adaptor kit for AF/NF
ZS-100	Weather shield (metal)
ZS-150	Weather shield (polycarbonate)
ZS-260	Explosion-proof housing
ZS-300	NEMA 4X housing

Note: When using AF24-SR US actuators, only use accessories listed on this page.

AF24-SR US Typical Specification

Spring return control damper actuators shall be direct coupled type which require no crankarm and linkage and be capable of direct mounting to a jackshaft up to a 1.05" diameter. The actuator must provide proportional damper control in response to a 2 to 10 VDC or, with the addition of a 500Ω resistor, a 4 to 20 mA control input from an electronic controller or positioner. The actuators must be designed so that they may be used for either clockwise or counterclockwise fail-safe operation. Actuators shall have control direction of rotation switch accessible on its cover. Actuators shall use a brushless DC motor controlled by a microprocessor and be protected from overload at all angles of rotation. Run time shall be constant, and independent of torque. A 2 to 10 VDC feedback signal shall be provided for position feedback or master-slave applications. Actuators shall be UL listed and CSA certified, have a 5 year warranty, and be manufactured under ISO 9001 International Quality Control Standards. Actuators shall be as manufactured by Belimo.

For Actuator Wiring Information and Diagrams,
Please See Belimo Wiring Guide (pg 349).

Wiring Diagrams

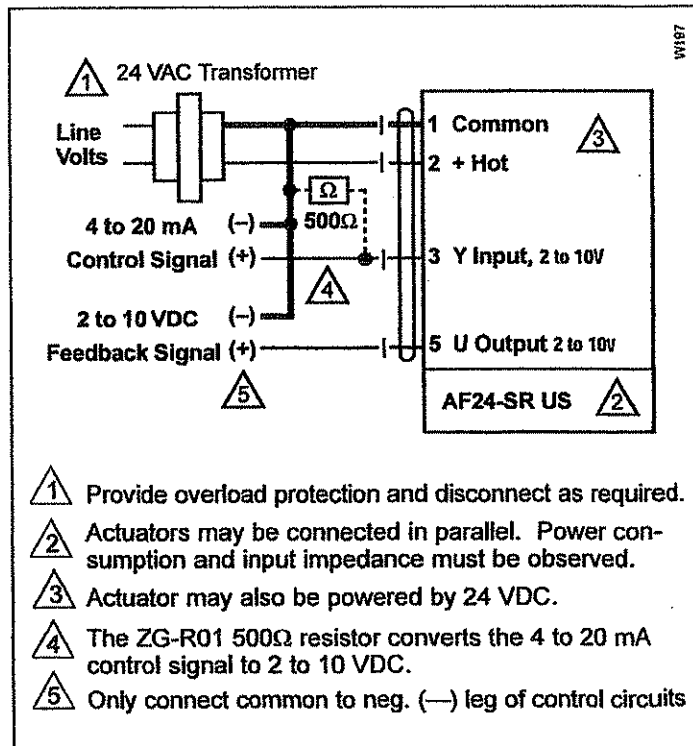
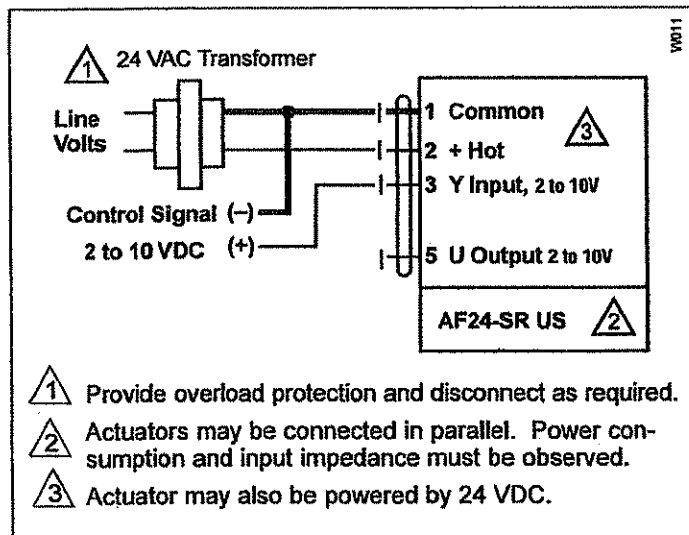

Determining Torque Loading and Actuator Sizing

Damper torque loadings, used in selecting the correct size actuator, should be provided by the damper manufacturer. If this information is not available, the following general selection guidelines can be used.

Damper Type	Torque Loading
Opposed blade, without edge seals, for non-tight close-off applications	3 in-lb/sq. ft.
Parallel blade, without edge seals, for non-tight close-off applications	4 in-lb/sq. ft.
Opposed blade, with edge seals, for tight close-off applications	5 in-lb/sq. ft.
Parallel blade, with edge seals, for tight close-off applications	7 in-lb/sq. ft.

The above torque loadings will work for most applications under 2 in. w.g. static pressure or 1000 FPM face velocity. For applications between this criteria and 3 in. w.g. or 2500 FPM, the torque loading should be increased by a multiplier of 1.5. If the application calls for higher criteria up to 4 in. w.g. or 3000 FPM, use a multiplier of 2.0.

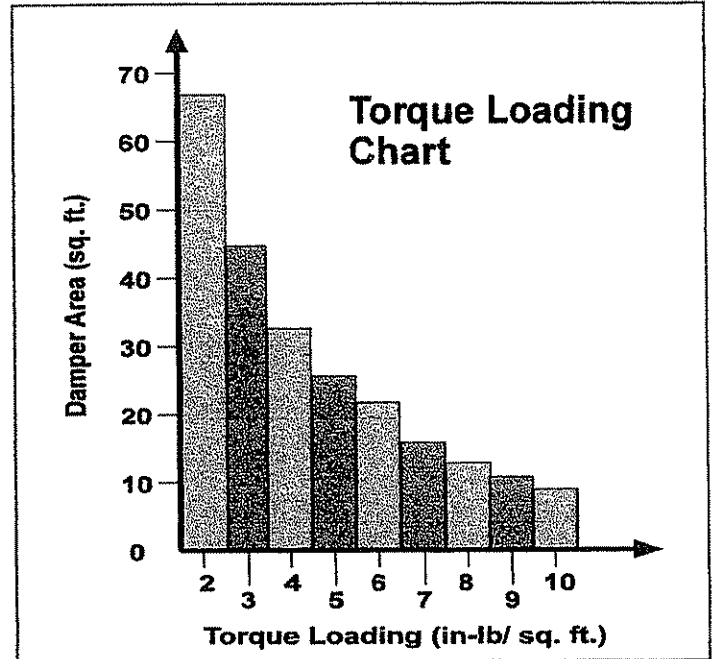

General Information

Belimo actuators should be mounted indoors in a dry, relatively clean environment free from corrosive fumes. If the actuator is to be mounted outdoors, a protective enclosure must be used to shield the actuator.

For new construction work, **order dampers with extended shafts**. Instruct the installing contractor to allow space for mounting and service of the Belimo actuator on the shaft. The damper shaft must extend at least 3 1/2" from the duct. If the shaft extends less than 3-1/2" or if an obstruction blocks access, the shaft can be extended with the AV 10-18 shaft extension accessory or the actuator may be mounted in its short shaft configuration.

Mechanical Operation

The actuator is mounted directly to a damper shaft up to 1.05" in diameter by means of its universal clamp. A crankarm and several mounting brackets are available for applications where the actuator cannot be direct coupled to the damper shaft. The AF series actuators provide true spring return operation for reliable fail-safe application and positive close-off on air tight dampers. The spring return system provides constant torque to the damper with, and without, power applied to the actuator. The AF...S versions are provided with 2 built-in auxiliary switches. These SPDT switches are provided for safety interfacing or signaling, for example, for fan start-up. The switching function at the fail-safe position is fixed at +5°, the other switch function is adjustable between +25 to +85°.

Automatic Airtight Dampers/Manual Override

The AF series provides 95° of rotation and is provided with a graduated position indicator showing 0° to 95°. The AF has a unique manual positioning mechanism which allows the setting of any damper position within its 95° of rotation. A pre-tensioned spring automatically tightens damper when power is applied to the actuator, compensating for damper seal deterioration. The actuator is shipped at +5° (5° from full fail-safe) to provide automatic compression against damper gaskets for tight shut-off. When power is applied, the manual mechanism is released and the actuator drives toward the full fail-safe position.

Standard Mounting

Note: The AF...series actuator is shipped with the manual override adjusted for a +5° position at the universal clamp (not at full fail-safe, 0°). This allows for automatic compression of damper blade seals when the actuator is in use, providing tight shut-off. This assumes that the damper is to have tight shut-off at the fail-safe position. If tight close-off is desired at the opposite direction from fail-safe, the manual override should be released so the actuator can go to the full fail-safe position. See the manual override instructions.

1. Manually move the damper to the fail-safe position (usually closed). If the shaft rotated counterclockwise (↺), this is a CCW installation. If the shaft rotated clockwise (↻), this is a CW installation. In a CCW installation, the actuator side marked "CCW" faces out, while in a CW installation, the side marked "CW" faces out. All other steps are identical.
2. The actuator is usually shipped with the universal clamp mounted to the "CCW" side of the actuator. To test for

adequate shaft length, slide the actuator over the shaft with the side marked "CCW" (or the "CW" side if this is the side with the clamp). If the shaft extends at least 1/8" through the clamp, mount the actuator as follows. If not, go to the *Short Shaft Installation* section.

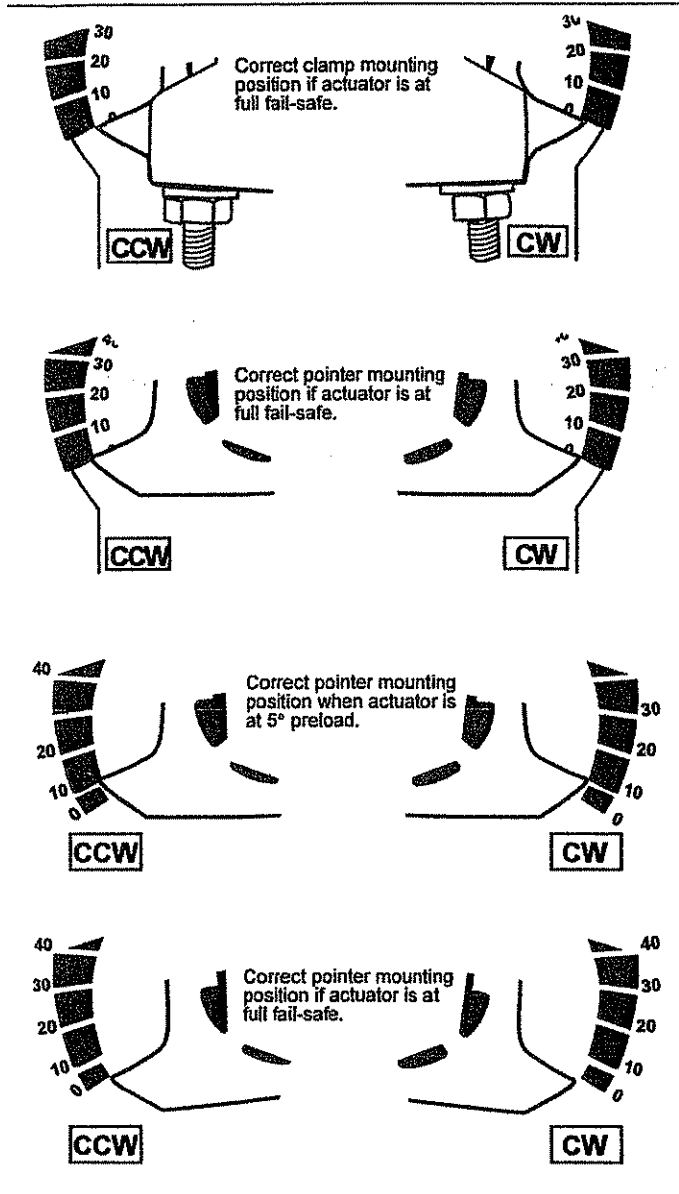

Fig. A Universal Clamp and IND-AF2 Pointer (optional) positions indicating fail-safe and pre-load settings

3. If the clamp is not on the correct side as determined in step #1, re-mount the clamp as follows. If it is on the correct side, proceed to step #5. Look at the universal clamp. If you are mounting the actuator with the "CCW" side out, position the clamp so that the pointer section of the tab is pointing to 0° (see Fig. C) and the spline section of the tab mates with spline of the actuator. Slip the clamp over the spline. (Use the same procedure if the "CW" side is out.) If your application requires a mechanical minimum position, read the *Rotation Limiting, Mechanical Minimum Damper Position* section.

4. Lock the clamp to the actuator using the retaining clip.
5. Verify that the damper is still in its full fail-safe position.
6. Slide the actuator over the shaft.
7. Position the actuator in the desired location.
8. Tighten the two nuts on the clamp using a 10mm wrench or socket using 6-8 ft-lb of torque.
9. Slip the stud of the anti rotation strap into the slot at the base of the actuator. The stud should be positioned approximately 1/16 of an inch from the closed end of the slot. Bend the strap as needed to reach the duct. Attach the strap to the duct with #8 self tapping screws.

Short Shaft Installation

If the shaft extends at least 3/4" from the duct, follow these steps:

1. Determine the best orientation for the universal clamp on the back of the actuator. The best location would be where you have the easiest access to the V bolt nuts on the clamp.
2. Engage the clamp to the actuator as close as possible to the determined location.
3. Lock the clamp in place using the remaining retainer clip.
4. Verify that the damper is still in its full fail-safe position.
5. Slide the actuator over the shaft.
6. Position the actuator in the desired location.
7. Tighten the two nuts on the clamp using a 10mm wrench or socket using 6-8 ft-lb of torque.
8. Slip the stud of the anti-rotation strap into the slot at the base of the actuator. The stud should be positioned approximately 1/16 of an inch from the closed end of the slot. Bend the strap as needed to reach the duct. Attach the strap to the duct with #8 self tapping screws.
9. If damper position indication is required, use the optional IND-AF2 pointer. See Fig. A.

Jackshaft Installation

The AF... series actuator is designed for use with jackshafts up to 1.05" in diameter. In most applications, the AF actuator may be mounted in the same manner as a standard damper shaft application. If more torque is required than one AF actuator can provide, a second AF actuator may be mounted to the jackshaft using the ZG-102 multiple actuator mounting bracket. See *wiring guide for wiring details*.

AF actuators which may be used on one shaft:	
Model	Max Quantity Per Shaft
AF24 (-S) US	4
AF120 (-S) US	
AF230 (-S) US	
AF24-SR US	4
AF24-MFT (-S) US	4

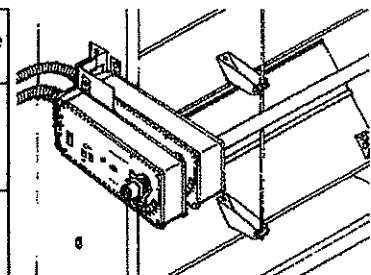

Mounting:

If the actuators are mounted on the opposed ends of the shaft, the actuator direction must be selected carefully. Usually, the direction of rotation is reversed.

Dimensions (All numbers in brackets are in millimeters.)

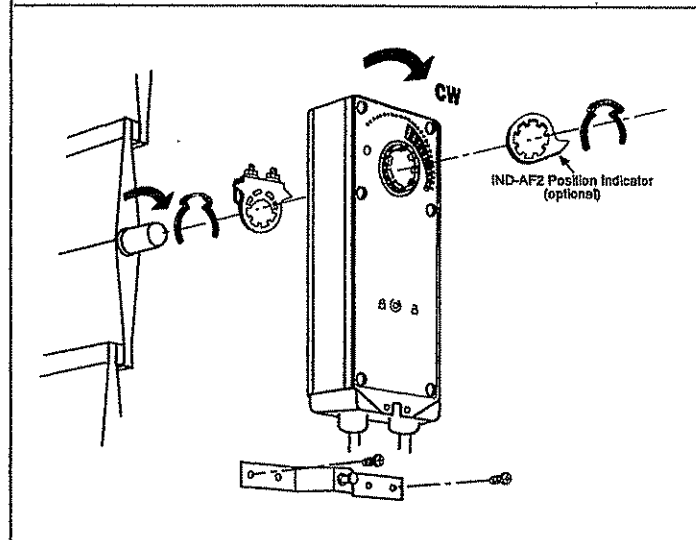
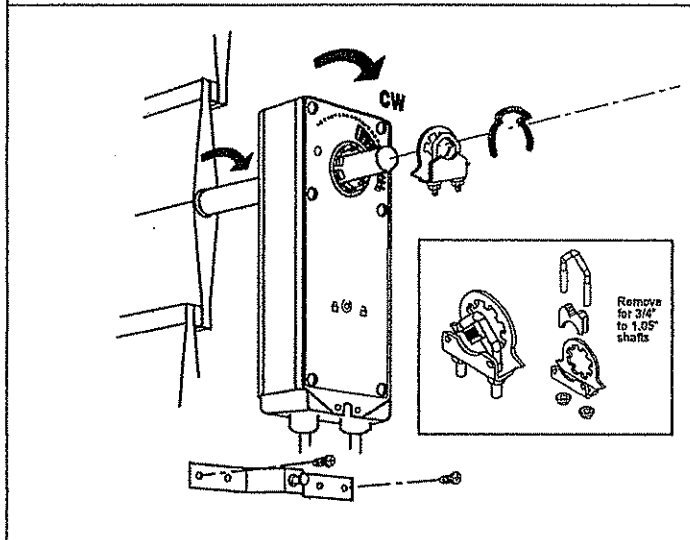
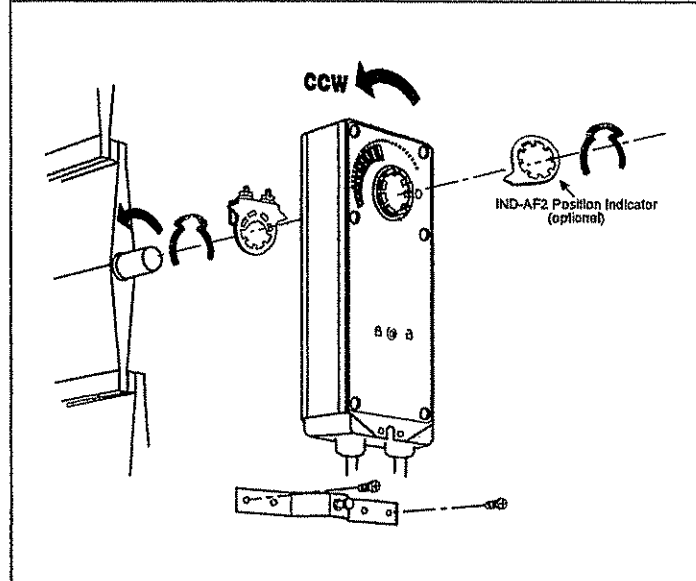
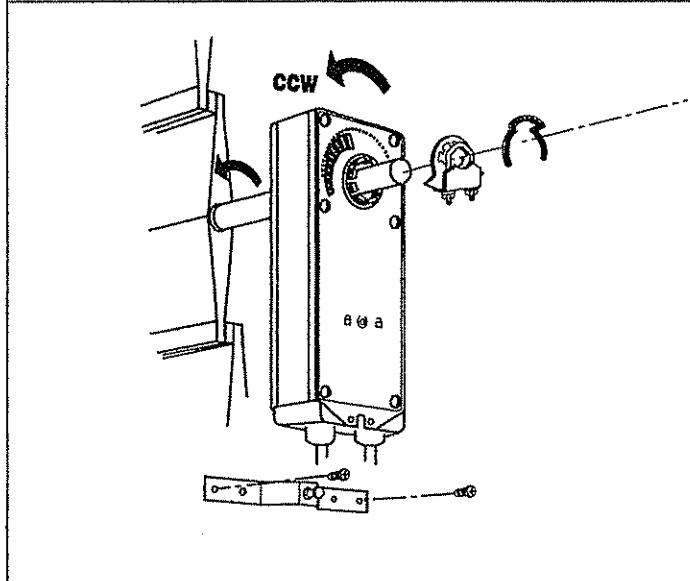
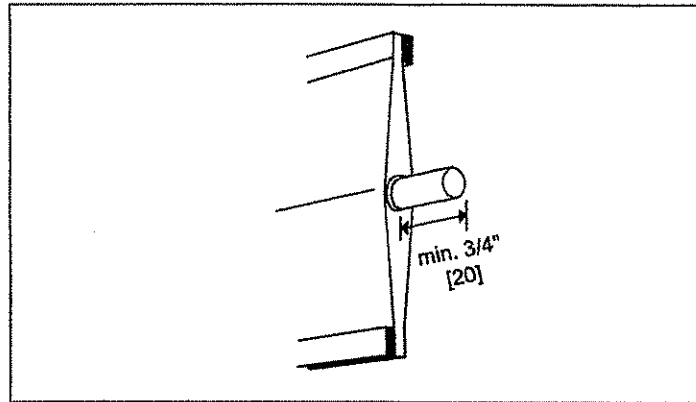
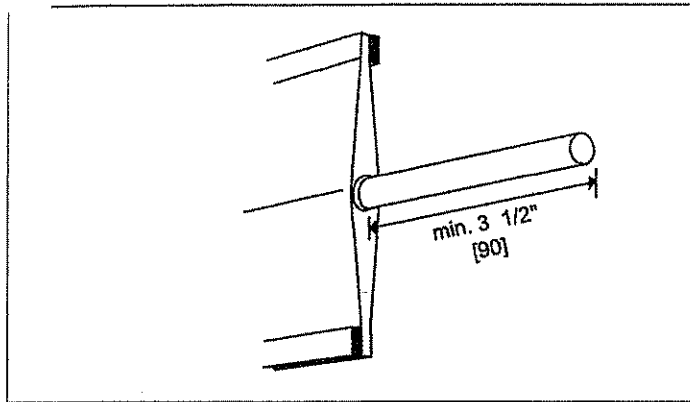

QUICK-MOUNT VISUAL INSTRUCTIONS

- 1 Rotate the damper to its fail-safe position. If the shaft rotates counterclockwise, mount the "CCW" side of the actuator out. If it rotates clockwise, mount the actuator with the "CW" side out.
2. If the universal clamp is not on the correct side of the actuator, move it to the correct side.

3. Slide the actuator onto the shaft and tighten the nuts on the V-bolt with a 10mm wrench to 6-8 ft-lb of torque.
4. Slide the anti-rotation strap under the actuator so that it engages the slot at the base of the actuator. Secure the strap to the duct work with #8 self-tapping screws.

NOTE: Read the "Standard Mounting" instructions, on the next page, for more detailed information.

Multiple Actuator Mounting

If more torque is required than one AF actuator can provide, a second AF actuator may be mounted to the shaft using the ZG-102 multiple mounting bracket.

Notes: The manual positioning mechanism cannot be used in multiple actuator applications.

Special Wiring and Additional Information: See wiring guide

Rotation Limitation

The angle of rotation limiter, ZDB-AF2, is used in conjunction with the tab on the universal clamp or IND-AF2 position indicator which comes with the ZDB-AF2. In order to function properly, the clamp or indicator must be mounted correctly. See Fig. A.

The ZDB-AF2 may not work in certain mounting orientations using the ZG-106 or ZG-107 mounting brackets. It will not work with the ZG-108 mounting bracket. Limiting the damper rotation must be accomplished by adjusting the crankarm linkage.

The ZDB-AF2 may be used in 2 ways to control the rotational output of the AF series actuator. One use is in the application where a damper has a designed rotation less than 90°. An example would be a 45° or 60° rotating damper. The other application would be to set a minimum damper position which can be easily set or changed without having to remove the actuator from the damper.

Damper Rotation Limiting

1. Determine the amount of damper rotation required.
2. Locate the Angle of Rotation Limiter (ZDB-AF2) on the actuator so that its edge lines up with the degree graduation on the actuator face which corresponds with the required rotation. See Fig. C.

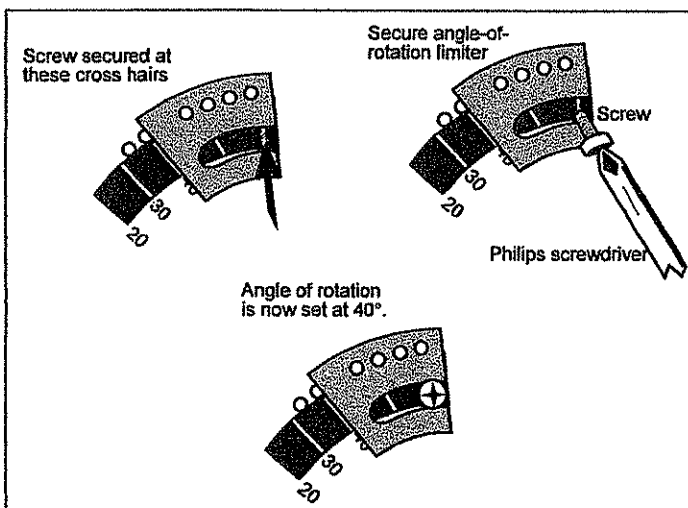

Fig. C ZDB-AF2 Securing the Angle of Rotation Limiter

3. Find the appropriate cross-hair location through the slot of the limiter. This is the screw mounting location.
4. Pierce through the label material to allow easy fastening of the retaining screw.
5. Position the limiter back to the desired position, making sure the locating "teeth" on the limiter are engaged into the locating holes on the actuator.

6. Fasten the limiter to the actuator using the self tapping screw provided.
7. Test the damper rotation either manually with the manual crank or apply power and if required, a control signal. Re-adjust if necessary.

Mechanical Minimum Damper Position

In order to use this procedure, the actuator must be mounted for short shaft mounting. See pages 8 & 10.

1. Position the damper to its minimum position by using the manual crank or by providing the appropriate control signal to the AF24... modulating type actuator.
2. Place the indicator on to the actuator spline in the approximate position shown in Fig. D. Fasten it with the retaining clip. Note that the mounting orientation is different than the mounting used for *Damper Rotation Limiting*.

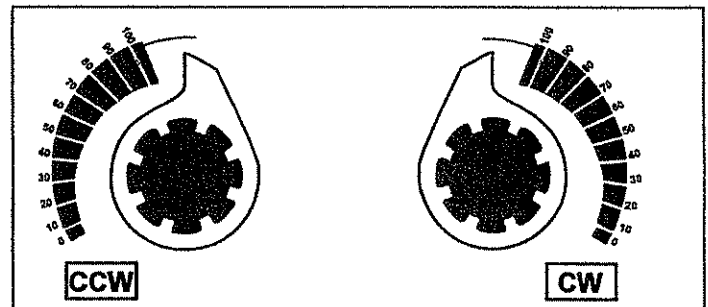

Fig. D

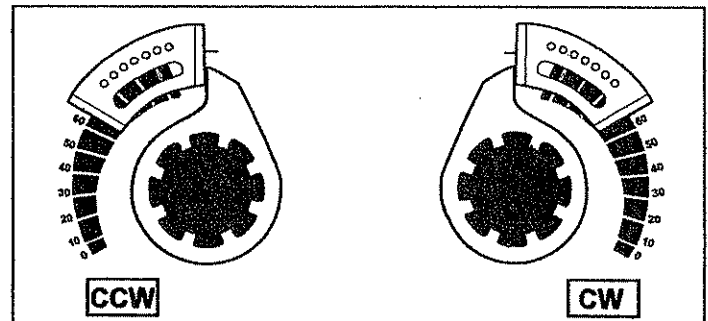

Fig. E

3. Place the ZDB-AF2 rotation limiter on the actuator so that it either makes contact with, or is as close as possible to, the edge of the indicator. See Fig. E. Make sure that the locating teeth are engaged into the locating holes on the actuator. If all of the mounting teeth do not align with the holes, the mounting location of the indicator to the spline may have to be moved. The limiter would then be remounted to get the best position match of both parts.
4. Find the cross-hair location through the slot of the limiter. This is the screw mounting location.
5. Pierce through the label material to allow easy fastening of the retaining screw.
6. Fasten the limiter to the actuator using the self tapping screw provided.
7. Test the damper operation either manually with the manual crank or apply power and if required, a control signal. Re-adjust if necessary.

This method should not be used for outside air damper applications. The damper will never go to the full close-off position. This may cause coils to freeze or other system problems. The AF24-SR (-S) US wired to either the SGA24 or SGF24 can be used for minimum position setting and still provide full close-off.

Manual Override

The AF series actuators can be manually positioned to ease installation or for emergency positioning.

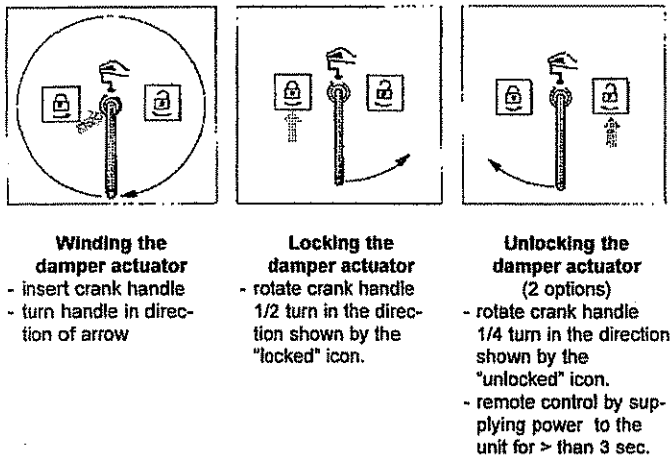

1. The manual override will only work if no power is available to the actuator.
2. Insert the manual crank (shipped with the actuator) into the hexagon hole located on either side of the actuator. An illustration, located on the label, shows the location.
3. Turn the crank in the direction shown on the label (clockwise on the "CW" side, counterclockwise on the "CCW" side). It will take approximately 19 revolutions to rotate the full 95° of rotation.
4. To lock the actuator in the required position, rotate the crank quickly in the opposite direction, 1/2 of a revolution. The "lock closed" icon on the label shows the correct direction.
5. The manual override may be disengaged in 2 ways.
 - Rotate the crank about a 1/4 revolution in the same direction as the initial winding. The "lock open" icon shows the correct direction.
 - Apply power to wire 1 and 2. The actuator will automatically disengage the override function and will go to the "on" position in the case of the on-off versions. Or, in the case of the proportional versions, go to the 0 signal position and then go to the position corresponding to the control signal. The actuator will now work normally.

Testing the installation Without Power

The actuator/damper installation may be tested without power at the actuator. Refer to the manual positioning section of the instructions. Move the damper to its full non-fail-safe position using the manual crank. Disengage the manual position mechanism and have the damper go to full fail-safe position. Correct any mechanical problems and retest.

Auxiliary Switches

The AF series actuators may be ordered with 2 built-in SPDT auxiliary switches used for safety interfacing or signalling, for example, for fan start-up. The switch position near the fail-safe position is fixed at 5°. The other is adjustable between 25 and 85° of rotation. The crank, supplied with the actuator, or a 3mm allen wrench is used to adjust the switching position.

Switch Rating

Voltage	Resistive Load	Inductive Load
120 VAC	7A	5A
250 VAC	7A	2.5A

Two methods may be used to adjust the switching point of the adjustable switch.

Method 1 - See Fig. F

1. The actuator must be in its fail-safe position.
2. Insert the crank into the hexagon shaped hole located in the center of the adjustable switch pointer.
3. Rotate the crank until the switch pointer is at the desired switch point in degrees as shown.

Method 2 - See Fig. G

1. Position the damper to the point at which you want the switch to activate. This may be done by using the manual override or by providing the appropriate proportional signal to AF24... modulating type actuator. The position of the switch pointer is not important during this step.
2. Insert the crank into the hexagon shaped hole located in the center of the adjustable switch pointer.
3. Rotate the switch pointer to just past the switch point indicating arrow as shown.

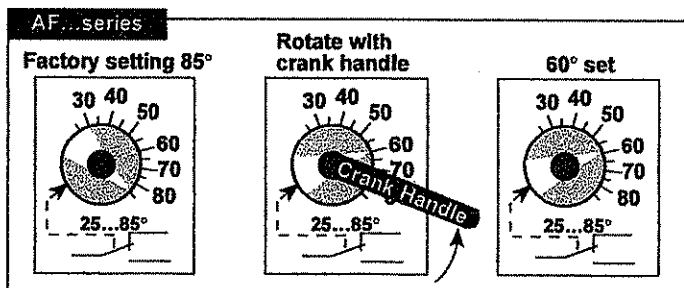

Fig. F

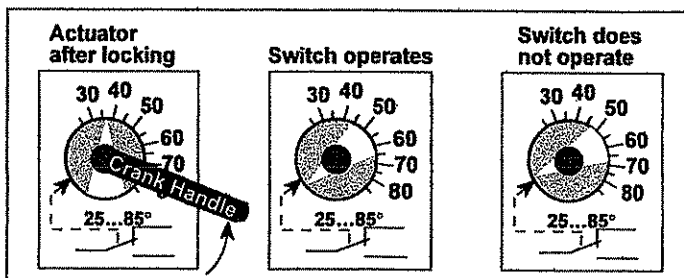
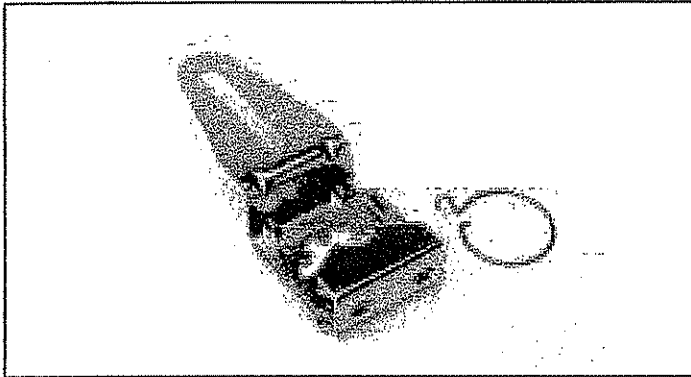

Fig. G

21

Non-direct Mounting Methods



KH-AF Crankarm Including Retaining Ring. *Caution:* the retaining clip supplied with the clamp is *not* used to mount the KH-AF crankarm.

The KH-AF (-1) crankarm is used in non-direct coupled mounting applications. The KH-AF (-1) may also be used to simultaneously direct couple to a damper shaft and provide an additional crank arm connection to a second damper. The KH-AFV V-bolt kit must be used for this non-direct application (see illustration below).

Two sizes are available:

KH-AF For round shafts up to 3/4" or square shafts up to 5/8"

KH-AF-1 For jackshafts up to 1.05"

KH-AFV V-bolt kit for KH-AF(-1) crankarm

Note: KH-AF (-1) crankarms cannot be used on AF Series 1 actuators.

Dimensions (All numbers in brackets are in millimeters.)

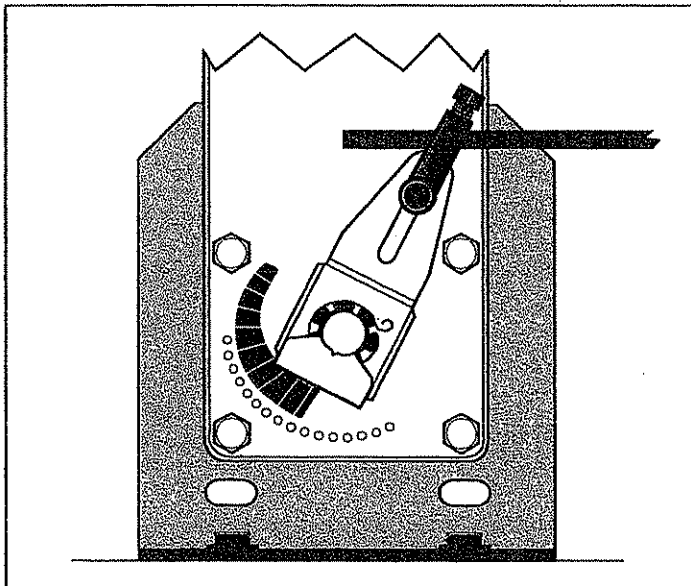
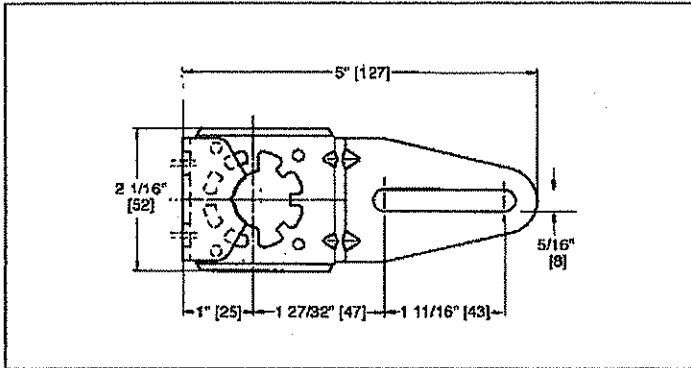

KH-AF non-direct mounting with ZG-108 mounting bracket

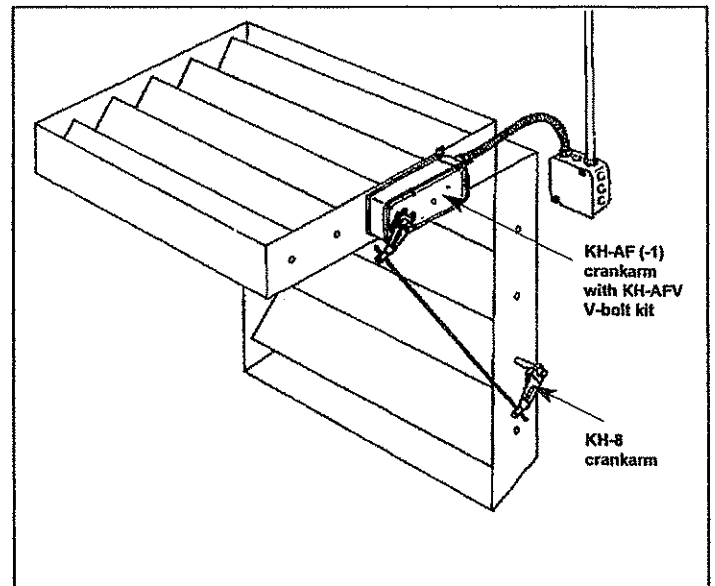

Multiple dampers direct coupled to one actuator with linkage to operate the other damper.

AF24-SR US and AF24-MFT US + P-100... Electrical Check-out Procedure

Step	Procedure	Expected Response	Gives Expected Response Go To Step...	Does Not Give Expected Response Go To Step...
1.	Control signal is applied to actuator.	Actuator will move to its "Control Signal" position.	Actuator operates properly Step 7.	No response at all Step 2. Operation is reversed Step 3. Does not drive toward "Control Signal Position" Step 4.
2.	Check power wiring. Correct any problems. See Note 1.	Power supply rating should be \geq the total power requirement of the actuator(s). Minimum voltage of 19.2 VAC or 21.6 VDC.	Power wiring corrected, actuator begins to drive Step 1.	Power wiring corrected, actuator still does not drive Step 4.
3.	Turn reversing switch to the correct position. Make sure the switch is turned all the way left or right.	Actuator will move to its "Control Signal" position.	Actuator operates properly Step 7.	Does not drive toward "Control Signal Position" Step 4.
4.	Make sure the control signal positive (+) is connected to Wire No 3 and control signal negative (-) is connected to wire No. 1. Most control problems are caused by reversing these two wires. Verify that the reversing switch is all the way CCW or CW.	Drives to "Control Signal" position.	Actuator operates properly Step 7.	Step 5.
5.	Check input signal with a digital volt meter (DVM). Make sure the input is within the range of the actuator. For AF24-SR US this is 2 to 10 VDC or 4 to 20 mA. Note: The input signal must be above the 2 VDC or 4 mA to have the actuator move.	Input voltage or current should be $\pm 1\%$ of what controller's adjustment or programming indicate.	Controller output (actuator input) is correct. Input Polarity Correct Step 6.	Reprogram, adjust repair or replace controller as needed Step 1.
7.	Check damper torque requirement.	Torque requirement is \leq actuator's minimum torque.	Defective Actuator. Replace Actuator - See Note 2.	Recalculate actuator requirement and correct installation.
8.	Actuator works properly. Test controller by following controller manufacturer's instructions.			

Note 1 Check that the transformer(s) are sized properly.

- If a common transformer is used, make sure that polarity is observed on the secondary. This means connect all No. 1 wires to one leg of the transformer and all No. 2 wires to the other leg of the transformer.
- If multiple transformers are used with one control signal, make sure all No. 1 wires are tied together and tied to control signal negative (-).
- Controllers and actuators must have separate 24 VAC/VDC power sources.

2 If failure occurs within 5 years from original installation date, notify Belimo and give details of the application.

STATE OF WEST VIRGINIA
Purchasing Division

PURCHASING AFFIDAVIT

VENDOR OWING A DEBT TO THE STATE:

West Virginia Code §5A-3-10a provides that: No contract or renewal of any contract may be awarded by the state or any of its political subdivisions to any vendor or prospective vendor when the vendor or prospective vendor or a related party to the vendor or prospective vendor is a debtor and the debt owed is an amount greater than one thousand dollars in the aggregate.

PUBLIC IMPROVEMENT CONTRACTS & DRUG-FREE WORKPLACE ACT:

West Virginia Code §21-1D-5 provides that: Any solicitation for a public improvement construction contract shall require each vendor that submits a bid for the work to submit at the same time an affidavit that the vendor has a written plan for a drug-free workplace policy in compliance with Article 1D, Chapter 21 of the West Virginia Code. A public improvement construction contract may not be awarded to a vendor who does not have a written plan for a drug-free workplace policy in compliance with Article 1D, Chapter 21 of the West Virginia Code and who has not submitted that plan to the appropriate contracting authority in timely fashion. For a vendor who is a subcontractor, compliance with Section 5, Article 1D, Chapter 21 of the West Virginia Code may take place before their work on the public improvement is begun.

ANTITRUST:

In submitting a bid to any agency for the state of West Virginia, the bidder offers and agrees that if the bid is accepted the bidder will convey, sell, assign or transfer to the state of West Virginia all rights, title and interest in and to all causes of action it may now or hereafter acquire under the antitrust laws of the United States and the state of West Virginia for price fixing and/or unreasonable restraints of trade relating to the particular commodities or services purchased or acquired by the state of West Virginia. Such assignment shall be made and become effective at the time the purchasing agency tenders the initial payment to the bidder.

I certify that this bid is made without prior understanding, agreement, or connection with any corporation, firm, limited liability company, partnership or person or entity submitting a bid for the same materials, supplies, equipment or services and is in all respects fair and without collusion or fraud. I further certify that I am authorized to sign the certification on behalf of the bidder or this bid.

LICENSING:

Vendors must be licensed and in good standing in accordance with any and all state and local laws and requirements by any state or local agency of West Virginia, including, but not limited to, the West Virginia Secretary of State's Office, the West Virginia Tax Department, West Virginia Insurance Commission, or any other state agencies or political subdivision. Furthermore, the vendor must provide all necessary releases to obtain information to enable the Director or spending unit to verify that the vendor is licensed and in good standing with the above entities.

CONFIDENTIALITY:

The vendor agrees that he or she will not disclose to anyone, directly or indirectly, any such personally identifiable information or other confidential information gained from the agency, unless the individual who is the subject of the information consents to the disclosure in writing or the disclosure is made pursuant to the agency's policies, procedures and rules. Vendors should visit www.state.wv.us/admin/purchase/privacy for the Notice of Agency Confidentiality Policies.

Under penalty of law for false swearing (West Virginia Code §61-5-3), it is hereby certified that the vendor acknowledges the information in this said affidavit and is in compliance with the requirements as stated.

Vendor's Name: _____

Authorized Signature: _____ Date: _____

BID BOND

KNOW ALL MEN BY THESE PRESENTS, That we, the undersigned, ERB Electric Company
of Bridgeport, Ohio, as Principal, and International Fidelity
Insurance Company
of Newark, New Jersey, a corporation organized and existing under the laws of the State of New Jersey with its principal office in the City of Newark, as Surety, are held and firmly bound unto the State of West Virginia, as Obligee, in the penal sum of Five Percent of the Total Amount Bid (\$ 5%) for the payment of which, well and truly to be made, we jointly and severally bind ourselves, our heirs, administrators, executors, successors and assigns.

The Condition of the above obligation is such that whereas the Principal has submitted to the Purchasing Section of the Department of Administration a certain bid or proposal, attached hereto and made a part hereof, to enter into a contract in writing for REQ.P.O.# DCH09029

Division of Culture and History
Grave Creek Archeology Complex Generator

NOW THEREFORE,

- (a) If said bid shall be rejected, or
(b) If said bid shall be accepted and the Principal shall enter into a contract in accordance with the bid or proposal attached hereto and shall furnish any other bonds and insurance required by the bid or proposal, and shall in all other respects perform the agreement created by the acceptance of said bid, then this obligation shall be null and void, otherwise this obligation shall remain in full force and effect. It is expressly understood and agreed that the liability of the Surety for any and all claims hereunder shall, in no event, exceed the penal amount of this obligation as herein stated.

The Surety, for the value received, hereby stipulates and agrees that the obligations of said Surety and its bond shall be in no way impaired or affected by any extension of the time within which the Obligee may accept such bid, and said Surety does hereby waive notice of any such extension.

IN WITNESS WHEREOF, Principal and Surety have hereunto set their hands and seals, and such of them as are corporations have caused their corporate seals to be affixed hereunto and these presents to be signed by their proper officers, this 28th day of October, 2008.

Principal Corporate Seal

ERB Electric Company

(Name of Principal)

By

Kathy J. Hill

(Must be President or Vice President)

Vice President

(Title)

Surety Corporate Seal

International Fidelity Insurance Company

(Name of Surety)

Nicholas A. Sparachane

Attorney-in-Fact

Nicholas A. Sparachane

IMPORTANT – Surety executing bonds must be licensed in West Virginia to transact surety insurance. Raised corporate seals must be affixed, a power of attorney must be attached.

POWER OF ATTORNEY INTERNATIONAL FIDELITY INSURANCE COMPANY

HOME OFFICE: ONE NEWARK CENTER, 20TH FLOOR
NEWARK, NEW JERSEY 07102-5207

FOR BID BOND/RIDER/CONSENTS/AFFIDAVITS

KNOW ALL MEN BY THESE PRESENTS: That INTERNATIONAL FIDELITY INSURANCE COMPANY, a corporation organized and existing laws of the State of New Jersey, and having its principal office in the City of Newark, New Jersey, does hereby constitute and appoint

NICHOLAS A. SPARACHANE, C. RICHARD STUMP

Wheeling, WV.

its true and lawful attorney(s)-in-fact to execute, seal and deliver for and on its behalf as surety, any and all bonds and undertakings, contracts of indemnity and other writings obligatory in the nature thereof, which are or may be allowed, required or permitted by law, statute, rule, regulation, contract or otherwise, and the execution of such instrument(s) in pursuance of these presents, shall be as binding upon the said INTERNATIONAL FIDELITY INSURANCE COMPANY, as fully and amply, to all intents and purposes, as if the same had been duly executed and acknowledged by its regularly elected officers at its principal office.

This Power of Attorney is executed, and may be revoked, pursuant to and by authority of Article 3-Section 3, of the By-Laws adopted by the Board of Directors of INTERNATIONAL FIDELITY INSURANCE COMPANY at a meeting called and held on the 7th day of February, 1974.

The President or any Vice President, Executive Vice President, Secretary or Assistant Secretary, shall have power and authority

- (1) To appoint Attorneys-in-fact, and to authorize them to execute on behalf of the Company, and attach the Seal of the Company thereto, bonds and undertakings, contracts of indemnity and other writings obligatory in the nature thereof and,
- (2) To remove, at any time, any such attorney-in-fact and revoke the authority given.

Further, this Power of Attorney is signed and sealed by facsimile pursuant to resolution of the Board of Directors of said Company adopted at a meeting duly called and held on the 29th day of April, 1982 of which the following is a true excerpt:

Now therefore the signatures of such officers and the seal of the Company may be affixed to any such power of attorney or any certificate relating thereto by facsimile, and any such power of attorney or certificate bearing such facsimile signatures or facsimile seal shall be valid and binding upon the Company and any such power so executed and certified by facsimile signatures and facsimile seal shall be valid and binding upon the Company in the future with respect to any bond or undertaking to which it is attached.



IN TESTIMONY WHEREOF, INTERNATIONAL FIDELITY INSURANCE COMPANY has caused this instrument to be signed and its corporate seal to be affixed by its authorized officer, this 29th day of August, A.D. 2003.

INTERNATIONAL FIDELITY INSURANCE COMPANY

STATE OF NEW JERSEY
County of Essex

[Handwritten Signature]
Secretary

On this 29th day of August 2003, before me came the individual who executed the preceding instrument, to me personally known, and, being by me duly sworn, said he is the therein described and authorized officer of the INTERNATIONAL FIDELITY INSURANCE COMPANY; that the seal affixed to said instrument is the Corporate Seal of said Company; that the said Corporate Seal and his signature were duly affixed by order of the Board of Directors of said Company.

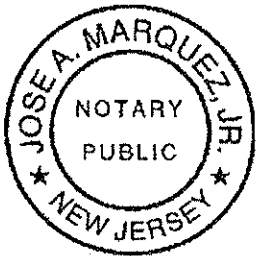

IN TESTIMONY WHEREOF, I have hereunto set my hand affixed my Official Seal, at the City of Newark, New Jersey the day and year first above written.

[Handwritten Signature]

A NOTARY PUBLIC OF NEW JERSEY
My Commission Expires Nov. 21, 2010

CERTIFICATION

I, the undersigned officer of INTERNATIONAL FIDELITY INSURANCE COMPANY do hereby certify that I have compared the foregoing copy of the Power of Attorney and affidavit, and the copy of the Section of the By-Laws of said Company as set forth in said Power of Attorney, with the ORIGINALS ON IN THE HOME OFFICE OF SAID COMPANY, and that the same are correct transcripts thereof, and of the whole of the said originals, and that the said Power of Attorney has not been revoked and is now in full force and effect

IN TESTIMONY WHEREOF, I have hereunto set my hand this 28th day of October 2008

[Handwritten Signature]
Assistant Secretary

CONTRACTOR LICENSE

Authorized by the
West Virginia Contractor Licensing Board

Number: WV003498

Classification:

ELECTRICAL

ERB ELECTRIC COMPANY INC
500 HALL STREET STE 1
BRIDGEPORT, OH 43912

Date Issued

SEPTEMBER 06, 2008

Expiration Date

SEPTEMBER 06, 2009

Kathy G. Heil
Authorized Company Signature

Michael A. Carl
Chair, West Virginia Contractor
Licensing Board

WEST VIRGINIA
CONTRACTOR
LICENSING
BOARD

This license, or a copy thereof, must be posted in a conspicuous place at every construction site where work is being performed. This license number must appear in all advertisements, on all bid submissions and on all fully executed and binding contracts. This license cannot be assigned or transferred by licensee. Issued under provisions of West Virginia Code, Chapter 21, Article 11.



PRODUCER:

BrickStreet Mutual Insurance Company
400 Quarrier Street
Charleston, WV 25301

CERTIFICATE HOLDER:

ERB ELECTRIC COMPANY
500 HALL ST SUITE 1
BRIDGEPORT, OHIO, 43912-1324

INSURED:

ERB ELECTRIC COMPANY
500 HALL ST SUITE 1
BRIDGEPORT, OHIO, 43912-1324

CERTIFICATE OF INSURANCE

The policy of insurance listed below has been issued to the insured named above for the policy period and coverage indicated. This certificate is issued as a matter of information only and confers no rights upon the certificate holder. This certificate does not amend, extend or alter the coverage afforded by the policy below. Coverage is contingent on the insured's compliance with policy conditions and premium payment.

If the policy is canceled before the expiration date, BrickStreet Mutual Insurance Company will endeavor to mail a written notice to the certificate holder within 30 days of cancelation. Failure to mail the notice shall impose no obligation or liability of any kind upon BrickStreet Mutual Insurance Company.

POLICY NUMBER: WC 10007443-05

DATE CERTIFICATE ISSUED: 07/22/2008

POLICY EFFECTIVE DATE: 07/04/2008

EXPIRATION DATE: 07/04/2009

WORKERS COMPENSATION AND EMPLOYERS LIABILITY

LIMITS / COVERAGE

WORKERS COMPENSATION - STATUTORY LIMITS

EMPLOYERS LIABILITY LIMITS:

BODILY INJURY BY ACCIDENT:	\$ 100,000.00	EACH ACCIDENT
BODILY INJURY BY DISEASE:	\$ 500,000.00	POLICY LIMIT
BODILY INJURY BY DISEASE:	\$ 100,000.00	EACH EMPLOYEE

**WV BROAD FORM EMPLOYERS LIABILITY ENDORSEMENT -
COVERAGE FOR WV CODE 23-4-2(d)(2)(ii)**

**FEDERAL COAL MINE HEALTH AND SAFETY ACT COVERAGE ENDORSEMENT -
COVERAGE FOR WV CODE 23-4b-1 - FEDERAL BLACK LUNG COVERAGE**

SPECIAL PROVISIONS IF ANY: